

Purchasing Division

ADDENDUM NO. 1

DATE: November
FROM: City of Grand Junction Purchasing Division
TO: All Offerors
RE: Persigo Wastewater Treatment Plant Control Structure #3 Slide Gate Replacement Project IFB-4722-19-DH

Offerors responding to the above referenced solicitation are hereby instructed that the requirements have been clarified, modified, superseded and supplemented as to this date as hereinafter described.

Please make note of the following clarifications:

1. Q. I want to make sure we properly select our bypass pumping equipment, and was wondering if you had an elevation/height for the catwalk that we would be attaching our discharge piping to? i.e. I want to account for static head and friction losses going from the bottom of the A-Basin up to those catwalks.

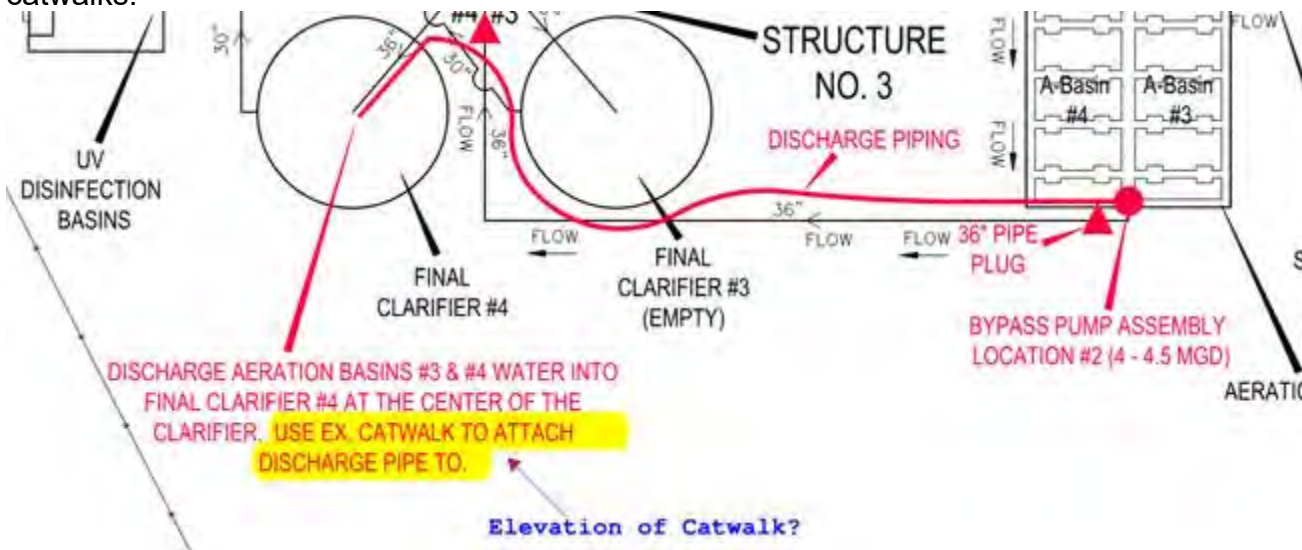

A. The height of the catwalks at the Final Clarifiers is between 3-5 feet above ground level.

2. Q. I also wanted to ask if we can get the product data sheets for the slide gates that would be installed? In particular I would be looking at weights, and any special mounting instructions/locations etc. And with that in mind; Do you guys know if you want to use the existing anchors, or would new anchors be desired? With new anchors we would have to make sure the new anchor locations are properly offset from the old locations etc.

- A. The slide gate submittals and installation instructions from Hydro Gate are attached to Addendum #1. It appears the Hydro Gate slide gates came with all of the stainless steel mounting hardware for mounting the gates to the concrete walls. Epoxy/adhesives for the stainless steel all-thread anchors shall be provided by the Contractor.

The Contractor shall install new anchors for the slide gates. Using the existing slide gate anchors will not be accepted.

3. Q. With the Bid on 12/04, and the desired project completion by 12/31, I was wondering if you folks had a specific start date in mind and how that would play into the Christmas holiday? I understand that we have 20 calendar days to complete all work (10 days for the bypass work), but was just curious how that time would work around the holiday? (e.g. Starting on the 12/05 would put the 20 day mark on Christmas Eve, vs starting the following Monday 12/09 would mean overlap with the holiday.)

A. It is up to the Contractor on when they want to start. As soon as the City receives the Contractor's bonds the City can issue the Notice to Proceed. The sooner the City receives the bonds the better. The City has stated December 9th is the earliest start date. If the Contractor can get the bypass pumping assembly setup somewhat quickly and the Contractor can remove and install the new slide gates before Christmas, the bypass pumps can be shut down before Christmas and the Contractor can remove the bypass pump assembly after Christmas. The Contractor is allowed to work 7-days a week and work as long of hours as the Contractor deems necessary.

4. Attached to Addendum #1 is the City approved Hydro Gate submittal and the Hydro Gate Installation and Operation instructions.

5. Attached to Addendum #1 are the as-built drawings for the perimeter troughs at the aeration basins where the 36" RCP effluent pipe exits the aeration basin troughs. Refer to Cross-section B V-14, which is the middle cross-section showing the elevation of the 36" RCP effluent pipe. It appears the invert elevation for the 36" RCP effluent pipe is 14.50. The top of the aeration basins (walking surface) is shown at elevation 25.00. The vertical difference is 10.50 feet. Both the east and west troughs should be identical.

Also, the plan view of the aeration basin is attached which shows the aluminum grating that will need removed for the suction pipes and/or submersible pumps to be installed for the bypass assembly.

6. In order for the contractor to plug the 36" RCP pipes at Control Structure #3, Persigo staff will have a couple pumps available to pump out the water within Control Structure #3. The Contractor will not be responsible for draining Control Structure #3. Persigo WWTP staff will also be responsible for draining the final clarifiers to a level that allows the contractor and/or a subcontractor to successfully install the necessary plugs needed to isolate Control Structure #3 for slide gate replacement. Persigo staff anticipates this exercise of draining the final clarifiers and getting Control Structure #3 drained will take 4-6 hours and will be a lot of coordinating. Bidders and Contractor's shall be aware that getting the final clarifiers and Control Structure #3 drained low enough to allow plug installation will take 4-6 hour and we may have to work one side of Control Structure #3 at a time.

7. Attached to Addendum #1 are photos of the hardware that came with the five new Hydro-Gate slide gates. All the hardware is labeled as 316 stainless steel. There are S.S. all-thread anchors, S.S. nuts and washers, hand-cranks, U-bolts, and 3M Edge Sealer. Adhesive/Epoxy for all-thread anchors and cementitious grout not included by Hydro Gate and/or the City. The Contractor will be

responsible for providing any additional S.S. hardware or materials not provided by Hydro Gate that is needed for the successful installation of the five (5) slide gates.

8. Submittals that the City will require from the Contractor are as follows:

- Aluminum Grating
- Bypass Pumping Plan and Emergency Contacts
- Grout
- Epoxy/Adhesive for S.S. all-thread anchors

The original solicitation for the project noted above is amended as noted.

All other conditions of subject remain the same.

Respectfully,

A handwritten signature in black ink, appearing to read "Duane Hoff Jr.", is written over a light gray rectangular background.

Duane Hoff Jr., Senior Buyer
City of Grand Junction, Colorado

SECTION A
SCALE 1/4" = 1'-0"

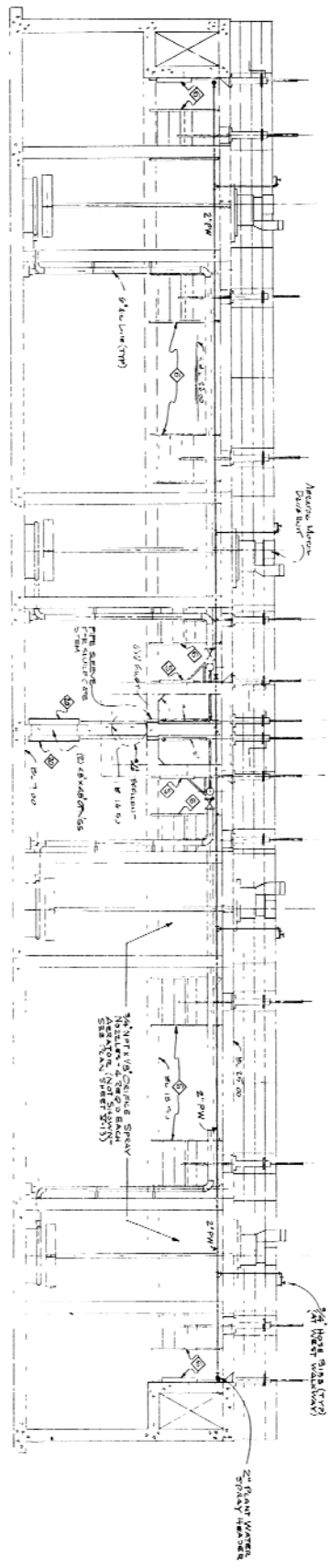

SECTION B
SCALE 1/4" = 1'-0"

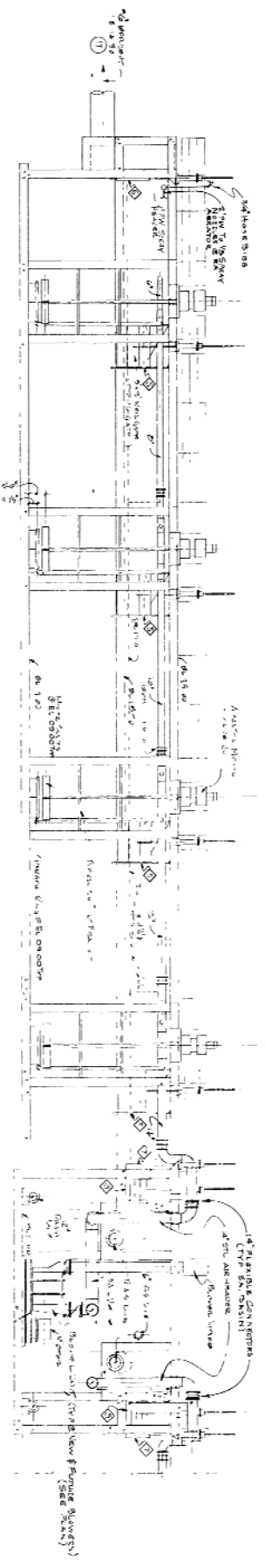

SECTION C
SCALE 1/4" = 1'-0"

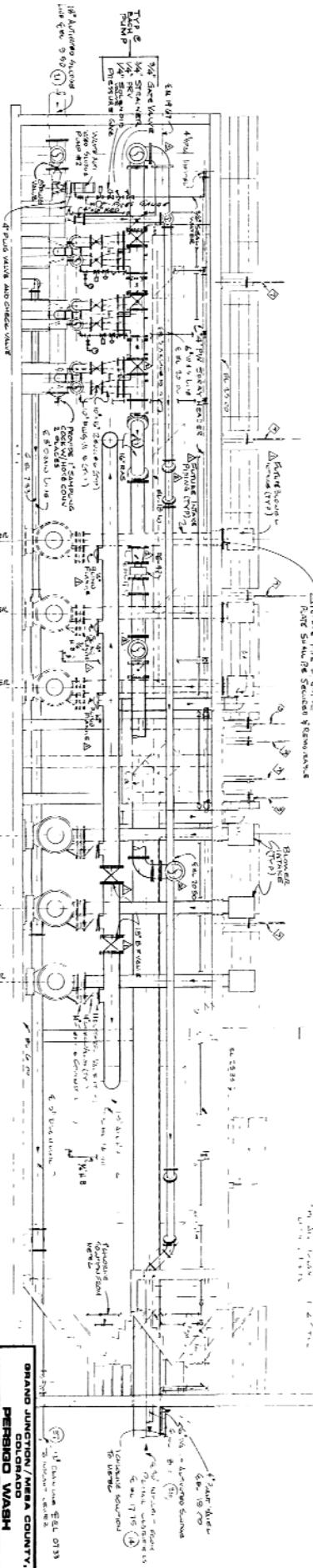

WILLIAM J. BLUNT
 LICENSED PROFESSIONAL ENGINEER
 LICENSE NO. 13114
 STATE OF COLORADO

**PERKINS WASH
 WASTEWATER TREATMENT
 PLANT**
 SECTION Z
 AERATION BASIN

DESIGNED BY
 ENGINEER
 DRAWN BY
 CHECKED BY
 APPROVED BY

PERKINS ENGINEERING & ARCHITECTURE, INC.
 734510
 GRAND JUNCTION, COLORADO

07037893.RIF



WALKWAY PLAN

07/07/2008 BH

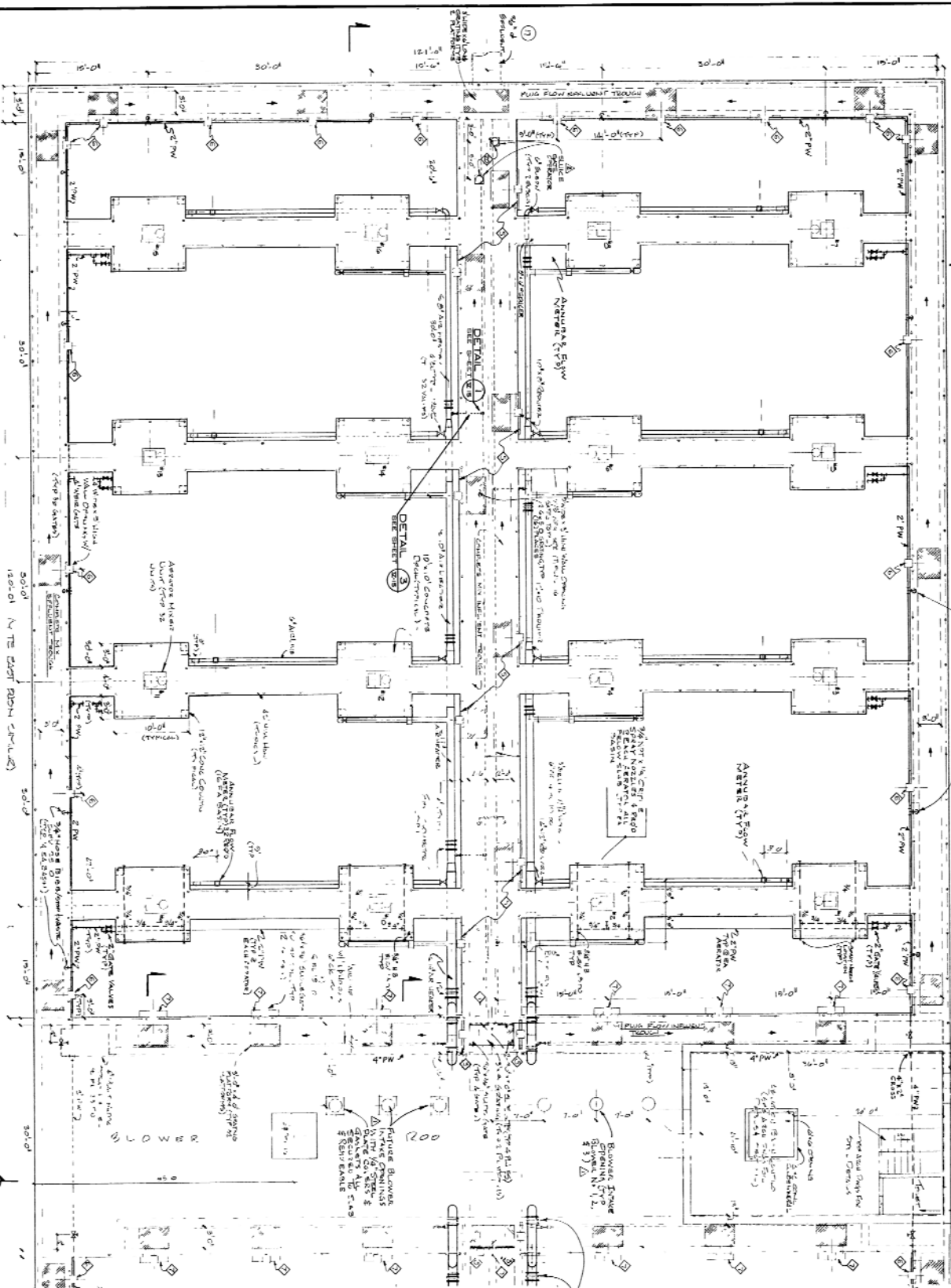

KEY MAP

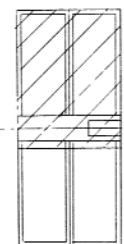

| NO. | DATE | DESCRIPTION | BY | CHK |
|-----|----------|--------------------|----|-----|
| 1 | 07/07/08 | ISSUED FOR PERMITS | BH | JK |
| 2 | 07/07/08 | REVISED PERMITS | BH | JK |
| 3 | 07/07/08 | REVISED PERMITS | BH | JK |
| 4 | 07/07/08 | REVISED PERMITS | BH | JK |
| 5 | 07/07/08 | REVISED PERMITS | BH | JK |
| 6 | 07/07/08 | REVISED PERMITS | BH | JK |
| 7 | 07/07/08 | REVISED PERMITS | BH | JK |
| 8 | 07/07/08 | REVISED PERMITS | BH | JK |
| 9 | 07/07/08 | REVISED PERMITS | BH | JK |
| 10 | 07/07/08 | REVISED PERMITS | BH | JK |

SECTION V
AERATION BASIN
WALKWAY PLAN
GRAND JUNCTION AREA COUNTY,
PERIOD WASH
WASTEWATER TREATMENT
PLANT
 PROCESS



DESIGNED BY: JAMES S. REYNOLDS
 DRAWN BY: JAMES S. REYNOLDS
 CHECKED BY: JAMES S. REYNOLDS
 DATE: 07/07/08

ENGINEER: JAMES S. REYNOLDS
 LICENSE NO. 13114
 STATE OF COLORADO

CONTRACT NO. 734-B10
 SHEET NO. 13

DATE: 07/07/08

PROJECT: GRAND JUNCTION AREA COUNTY, PERIOD WASH WASTEWATER TREATMENT PLANT

SECTION: SECTION V

PROCESS: AERATION BASIN

WALKWAY PLAN

GRAND JUNCTION AREA COUNTY, PERIOD WASH WASTEWATER TREATMENT PLANT

SECTION V

AERATION BASIN

WALKWAY PLAN

GRAND JUNCTION AREA COUNTY, PERIOD WASH WASTEWATER TREATMENT PLANT

SECTION V





Handwritten red text on the toolbox lid, including "1 1/2\" (10)", "1 1/4\" (10)", "1 1/8\" (10)", and "1\" (10)".





UTION MAY CAUSE
THE UNBORN



Edge Sealer 3950

0,236 L

Date of Manufacture: 27/FEB/2018

Use by Date: 27/FEB/2020

Lot Number: BG80901000

Run Number: BG80901000

Packer ID: DM



DANGER! FLAMMABLE LIQUID

Carefully read precautionary information



HG561 FABRICATED SLIDE GATES

G2500

Operation Instructions

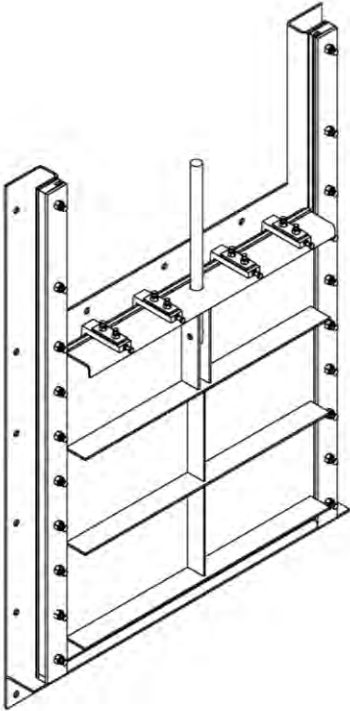

DO NOT DISASSEMBLE GATE FOR INSTALLATION

Hydro Gate
Registered to ISO 9001
Certificate No. HQ-Q-946

Revised 4/8/16

TABLE OF CONTENTS

| | |
|--|--------------|
| Cautionary Statement | i |
| Foreword | ii |
| INSTALLATION | |
| Safety Precautions | 1 |
| Things to Do and not to Do during Installation | 2 |
| General Mounting | 3 |
| Mounting the Gate on Concrete Surface with Adhesive Stub Anchors | 4-5 |
| Wall Thimble Installation | 6-7 |
| Installation on Thimble or Flange with Machined or Nonmachined face..... | 8-9 |
| Application of Sealant on Thimble | 10 |
| Correcting and Compensating for a Warped Thimble | 11 |
| Installation of Flush Bottom Closure Gates | 12 |
| Gate Stem and Guides Installation | 13-14 |
| Lift Installation and Adjustment of Stem Guides | 15 |
| Installation of Tandem Stem | 16 |
| Gate Adjustment | 17-18 |
| Manual Lifts, Parts, and Assemblies | 19 |
| Installation of Hydraulic Operating Cylinder, Stems, and Stem Guides to Gates | 20-21 |
| OPERATION | |
| General Operation Information | 22 |
| Fabricated Slide Gate Operation Procedures | 22-13 |
| MAINTENANCE | |
| Maintenance and Lubrication | 24-26 |
| Maintenance Schedule and Lubrication Summary | 26 |
| List of Lubricants | 27 |
| Leakage | 28 |
| Troubleshooting Tips | 29-30 |
| Long-Term Storage Instructions | 31 |
| Warranty | 32 |
| EXPLODED VIEW & PARTS LIST | 33-35 |
| Spare Parts..... | 36 |

**CAUTIONARY STATEMENT FOR INSTALLATION, OPERATION, &
MAINTENANCE MANUAL**

This manual describes the recommended procedures for installation, adjustment, operation and maintenance of Hydro Gate gates. When it is used in conjunction with installation drawings that have been supplied by Hydro Gate, this manual will be sufficient for most installations. Proper care and precautions must be taken in handling and storing the gates at the delivery site. For further details on the handling, storing, and installation of a specific project, contact Hydro Gate's headquarters.

PRECISE AND ACCURATE INSTALLATION IS CRITICAL TO SATISFACTORY OPERATION. HYDRO GATE ASSUMES NO LIABILITY, EXPRESSED OR IMPLIED, FOR INTERPRETATION OF THE CONTENTS OF THIS MANUAL. IF YOU HAVE ANY QUESTIONS CONCERNING THE INTERPRETATION OF THE CONTENTS OF THIS MANUAL OR INSTALLATION PROCEDURES IN GENERAL, YOU SHOULD CONTACT HYDRO GATE'S COLORADO FACILITY. HYDRO GATE EXPRESSLY DISCLAIMS ALL LIABILITY, EXPRESSED OR IMPLIED, FOR FAULTY INSTALLATION OF ANY GATE OR ASSOCIATED EQUIPMENT AND FOR ANY DIRECT, CONSEQUENTIAL, OR INCIDENTAL DAMAGES THAT MAY RESULT.

FOREWORD

The purpose of this Installation, Operation, and Maintenance Manual is to provide information on the correct procedures for installation, adjustment, operation, and maintenance of Hydro Gate HG561 Fabricated Stainless Steel Gates and their component parts.

The gate, lift, and accessories were accurately machined, fabricated, assembled, adjusted, and inspected before leaving the Hydro Gate Corporation factory. For best results, read and follow the applicable parts of this Manual carefully, including thorough cleaning and lubrication of moving parts and final wedge adjustment. If the gate will not be installed immediately, consult the long-term storage instructions following.

**Installation Note**

Do not disassemble the gate or lift for installation.

**Warranty Note**

Installation and/or operation of the gate lift and stem without proper lubrication will void the equipment warranty. Thorough cleaning of the stem and seating faces is required before gate operation. Details are described in the appropriate sections of this Manual.

Notes

- Spare Parts – Hydro Gate does not recommend the stocking of spare parts. If spare parts are required see table1 (last page). Replacement parts are readily available for worn or broken parts. Contact Hydro Gate or our representative in your area.
- Special Tools – Special tools are not required to operate and/or maintain the equipment supplied by Hydro Gate on this project.
- Price List – Prices for individual parts and/or assemblies may be obtained from Hydro Gate at the time that they are needed.
- Disassembly – Hydro Gate does not recommend the disassembly/reassembly of any of the equipment on this project.
- Emergencies – Emergency/shutdown procedures do not differ from normal operating procedures for this project. If you should need assistance, please contact Hydro Gate's Field Service Department at (303) 288-7873.

INSTALLATION

Safety Precautions

To help ensure your workers' safety, Hydro Gate recommends the personnel responsible for installation, operation, and maintenance of the gates for this project read and study the instructions and precautions in the Installation, Operation, and Maintenance Manual, and follow all directions carefully. The following are major items associated with safe installation, operation, and maintenance of this slide gate.

- **Do not** operate equipment before carefully reviewing the Installation, Operation, and Maintenance Manual.
- Always use proper equipment when lifting or unloading heavy items.
- **Do not** stack equipment too high for storage. Always use heavy wood blocking between equipment. Refer to the storage instructions contained herein for details.
- Adequately support and brace heavy items during placement of equipment.
- Wear proper personal protective equipment (PPE) and clothing when working on or around gates, (e.g., hard hats, heavy boots, safety glasses, and breathing apparatus, if necessary).
- **Never** place bodily obstructions in the path of moving parts. When operating gates and accessories, stand clear of all moving parts. Serious injury can result from contact with moving parts.
- Use caution when performing operations and maintenance. Watch for loose or damaged parts. Stop all functions until any damage has been corrected.
- **Do not** use any mechanical devices other than the factory-supplied equipment to operate the gates for this project.
- **Do not** attempt operational procedures other than set forth in the Installation, Operation and Maintenance Manual.
- Contact your Hydro Gate representative with any questions you may have regarding safety in installing, operating, and handling Hydro Gate products.

Things To Do and Not To Do during Installation of This Gate

To properly install this gate, Hydro Gate recommends that personnel study these instructions and installation drawings and follow the installation directions carefully. This gate is shop adjusted, quality checked, and designed for low leakage. Attention must be given to proper storage, careful handling, and accurate location of embedded items for this gate to operate as designed.

Some DO'S and DON'TS to ensure proper gate installation.

- ✓ DO – Read and follow the Installation instructions and drawings in this Manual.
- ✓ DO – Carefully inspect the gates and accessories when received, before unloading trucks or cars. Report **ALL** shortages or suspected damage by marking the Bill of Lading and Receiving Reports at this time. Latent shortages must be reported in writing within 30 days of shipment.
- ✓ DO – Store gates evenly on planks or timbers. Even the heaviest castings are subject to permanent warpage if unevenly blocked during storage.
- ✓ DO – Support full length of stems and protect threads during storage and handling.
- ✓ DO – Accurately locate and brace embedded items during placement of concrete.
- ✓ DO – Contact your Hydro Gate representative with questions regarding this gate. Hydro Gate and its related companies have 100 years combined experience in the water control industry.
- ✓ DON'T – Disassemble the gates for installation.
- ✓ DON'T – Allow excess concrete to overlap gate thimble or frame.
- ✓ DON'T – Tighten nuts for studs unevenly, or try to pull a gate frame tightly against an uneven wall surface. This, in most cases, will cause excessive leakage.
- ✓ DON'T – Operate gates with concrete and debris on them.
- ✓ DON'T – Operate gate stems dry (without grease).

General Mounting

HG561 Fabricated Stainless Steel Gates are most commonly mounted on stud anchor bolts and grout pads; however, they may also be mounted on a fabricated thimble or flange or on machined flanges and thimbles. The gate flange is not machined. A thick layer of hard setting mastic is required between gate and the thimble or pipe flange. Recommended mastic is polyurethane sealant such as Sika-Flex 1A or equivalent. Normal polyurethane sealants require 36+ hours setting time before submerging. Fast cure polyurethane sealants are available (These are glass and windshield setting compounds). They are a good alternative; however, their fast setting property requires quick, well-planned installation and clean up of hardened material is difficult.

Foam (Polyurethane) gasket may also be used. Consult Hydro Gate's Engineering Department for additional information.

Installation Note

Thin solid rubber gaskets are not satisfactory. Gaskets, gasket materials, and mastic are not furnished by Hydro Gate.

Flanges for gate mounting must be flat (non-warped) within +/- 1/16 inch. The gate can function with some twist/warp/non-flat conditions. The larger the gate, the more out-of-plane conditions can be tolerated. Consult factory for extreme limits.

Mounting the Gate on Concrete Surface with Adhesive Type Stud Anchors

1. Use only adhesive-type or epoxy-grouted studs. Mechanical wedge studs are not recommended and gate performance cannot be guaranteed with wedge-type studs. Hydro Gate usually furnishes the all-thread studs but does not furnish the adhesive capsules or cartridges.



Adhesive such as Hiti HY200 or HIT-RE 500-SD is not supplied by Hydro Gate due to its stringent storage requirements and limited shelf lifetime

2. Accurately layout positions of studs or use the gate as a template.
3. Drill holes to diameter and depth required for size studs used. If rebar is encountered during drilling causing an impossible completion of hole, consult the owner's site engineer for instructions on how to proceed. Cutting of rebar may not be permitted. In some cases, a new hole (or holes) may be field drilled in the gate frame to compensate for out of position studs. Consult Hydro Gate's Engineering Department for advice and limitations.
4. Blow and brush all holes clean according to adhesive system instructions and place studs with adhesive. Maintain proper projection and alignment and allow sufficient cure time, particularly in cold weather.



Safety Note Concerning Mechanical Studs

Because of the dynamic/reversing load on the gates involving unseating or seating loads and the use of front and back nuts for alignment, wedge studs are not satisfactory since they require tension in them at all times to "grip" the concrete. The loss of "tension" in the wedge stud may cause them to fail.

5. Two nuts are provided for each stud bolt (**Figure 1**). These are for precise plumbing and alignment with a nut on both sides of the gate flange.
6. Check the placement and plumbness of pattern of stud bolts. Fit check the gate onto stud bolts. Perform minor bending adjustment to studs, as needed.
7. Clean stud bolt threads. Apply anti-galling compound (anti-seize) and run one nut on each stud up to or near the concrete.
8. Establish a plumb/vertical plane with back nuts starting with the two upper corner stud bolt back nuts. Leave room for grout and some in/out adjustment from the wall. With plumbline or builder's level and straight edge, bring all other nuts to a vertical plane established by upper corner nuts.
9. Being sure flange of gate is clean, place the assembled gate over/on the stud bolts. Run the front nuts on stud bolts until they touch the gate flange.
10. Take note of how well the gate frame fits the previously established flat vertical plane of back nuts on studs. Some variation of the free-hanging gate flatness is normal (1/8 inch in small/medium sized gates; 1/4 inch in large gates).

11. Tighten the front nuts on side studs until frame contacts back nuts. Tighten the two nuts against each other, against the frame flange.
12. Note that the gate slide should be in tight contact with seals at horizontal frame members. Some curvature or non-flatness of frame member may be required for good seal contact with the slide. Tighten front and back nuts up to the flange while observing that no gap between the slide and horizontal frame seal exists or develops.
13. Grouting of gate frames is not recommended until after the lift and stem has been installed and gate has been cycled open/close to ensure smooth operation.
14. After operation has been verified, carefully pack the space between the gate and the wall around the opening with "non-shrink" grout. Alternatively, the space may be formed and slurry grouted with concrete. Grouting behind the frame guide (legs) extensions is not necessary.
15. Be sure the frame extension stud bolts are in place and front and back nuts are tight and hold the frame stable.

Figure 1 – Top View of Stud Bolt Mounting

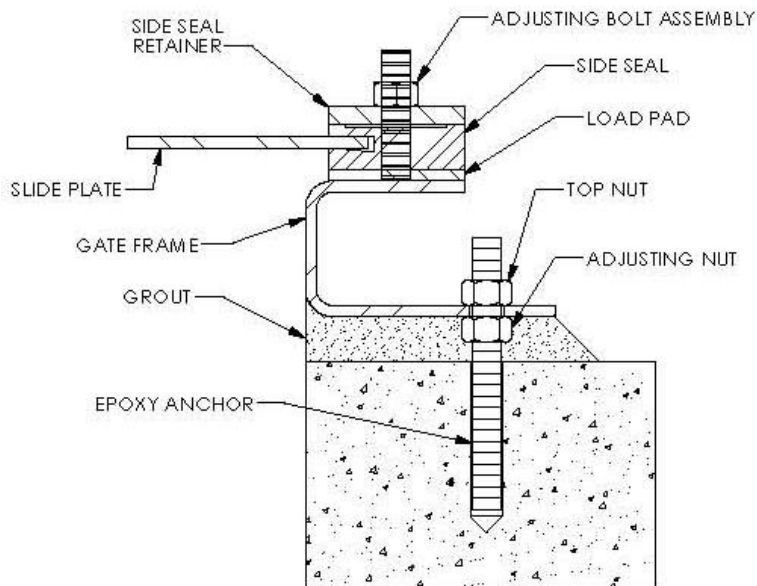

Wall Thimble Installation

1. Place the wall thimble in the correct position in the forms and block it in this position. The top centerline of the thimble is stamped on its flange face. The bottom centerline is also marked
2. Plumb the front face of the thimble using the marks indicating top and bottom centerline. This face should be plumbed with respect to final location of the gate, stem, and lift.
3. Studs furnished for attaching the gate may be used in the attachment of the thimble to the forms. If these studs are not used, threaded holes in the thimble must be plugged to prevent concrete from entering them.
4. Use timbers or other bracing material on the inside opening of the thimble while concrete is being poured (**Figure 2**).

**Installation Note**

Use extreme care in placing of these supports to prevent warping of the thimble.

5. Pour concrete, being careful not to tilt the thimble from its original position in the forms.
6. Remove forms and bracing.

Figure 2 – Front and Side View of Thimble Showing Bracing

Block out for top anchors or
place J-bolt anchors in form
for concrete pour.
See installation drawing for
location.

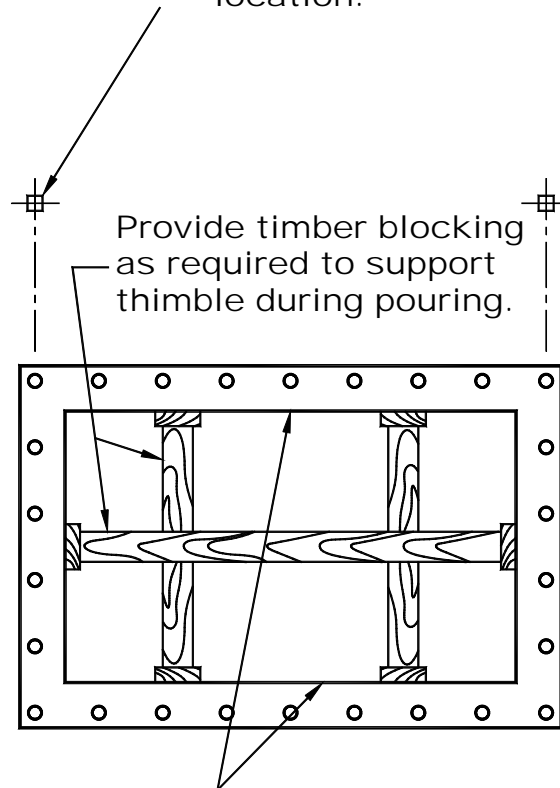

Provide timber blocking
as required to support
thimble during pouring.

Plumb thimble in forms
using top and bottom.

Installation on Thimble or Flange with Machined or Nonmachined Face

1. Clean face of thimble with scrapers and wire brush so no sand, concrete, dirt, or foreign material are present (**Figure 3**).
2. Check for flatness and plumb of thimble face to verify that it did not move or shift during concrete pour. Flatness must be within 1/64 inch of true flat plane. The thimble should be plumb with 1/8 inch. Use good quality plumb level, or plumb lines, at each vertical side. Both sides should be plumb or parallel to each other within 1/32 inch over total height.
3. After verifying thimble flatness and alignment, install thimble stud bolts.
4. Check the installation drawings for use of anchor bolts to stabilize the upper frame guides or extensions. If shown on the installation drawing, install a nut on these anchors and run on as far as possible before installing the gate.
5. Trowel a thin layer (1/16 inch to 1/8 inch thick) of mastic on the face of the thimble or two ½ inch diameter beads of mastic from a caulking gun; one bead midway between the inner edge of the face (opening) and the row of studs and the other bead just outside the row of studs. Place a circular bead around each stud. These beads should be of size and placement so they will flow out and substantially cover or wet the flange joint. Trowel able grades of asphalt roof cement, or polyurethane sealants (Sika-Flex 1-A or equivalents), works wells as mastic.
6. Although Hydro Gate does not recommend using rubber gaskets in place of mastic, they may be used at the discretion of the owner or consulting engineer. They should be no more than 1/8 inch thick and the thimble must be flat within the 1/32 inch total maximum warping allowed. Use of thicker gaskets may result in a spongy foundation for the gate or blowout under high unseating heads.
7. Tighten all stud nuts uniformly. See the torque table shown below. It is not mandatory that nuts be tightened precisely to these values. Repeated tightening with a torque wrench will be required to squeeze mastic to a thin layer for metal-to-metal contact.
8. Use caution when mounting gates on nonmachined steel structures, round flanges, or existing thimbles. The rules of flatness discussed above apply. Severe distortion of the gate and subsequent excessive leakage results when torque tightening gate mounted on uneven/non-flat surfaces. Do not torque tighten a gate to an uneven non-flat surface.

Torque Table for Tightening Nuts

| Capscrew Diameter (Inches) | Torque Specifications (Pound Feet) |
|--|---------------------------------------|
| 5/8 | 90 |
| 3/4 | 128 |
| 1 | 285 |
| 1 1/4 | 500 |
| Use "Anti-Seize" Lubricant on All Threads. | |

Figure 3 – Front Cross Section of Thimble Showing Machined Front Face

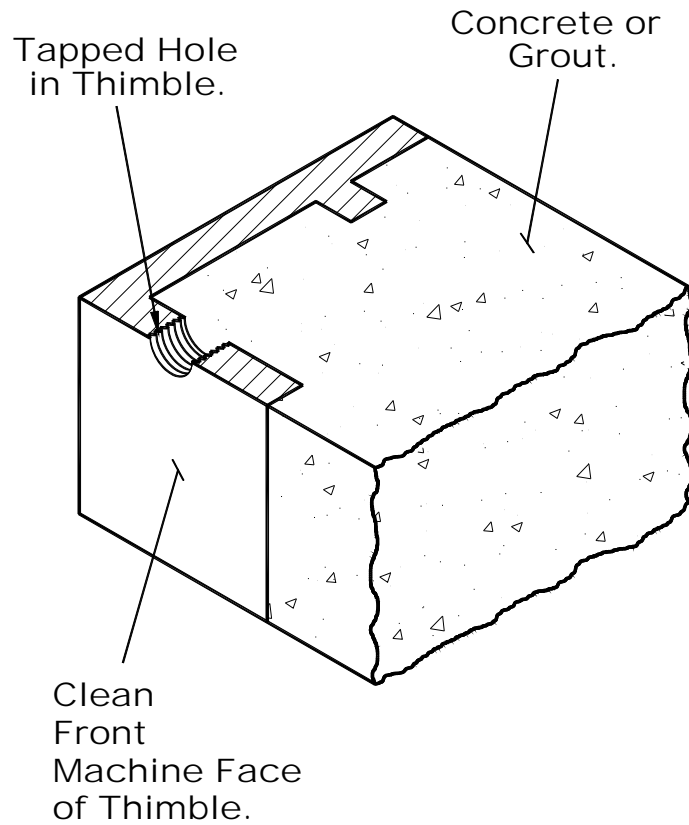

"F" Wall Thimble
Typical Thimble Installation

Application of sealant on Thimble

1. Thoroughly clean both mounting face of the slide gate and the wall thimble mounting flange.
2. Install of the mounting stud bolts into the wall thimble
3. Apply two continuous beads of sealant around the wall thimble flange and around each stud.
4. Install the gate over the mounting studs and thread on the flat washers and hex nuts.
5. Utilizing a torque wrench tighten all of the mounting stud bolts evenly. Tighten the mounting bolts in accordance with the torque table.
6. In approximately 24 hours after the sealant has begun to set, re-tighten the mounting evenly again with the torque wrench.

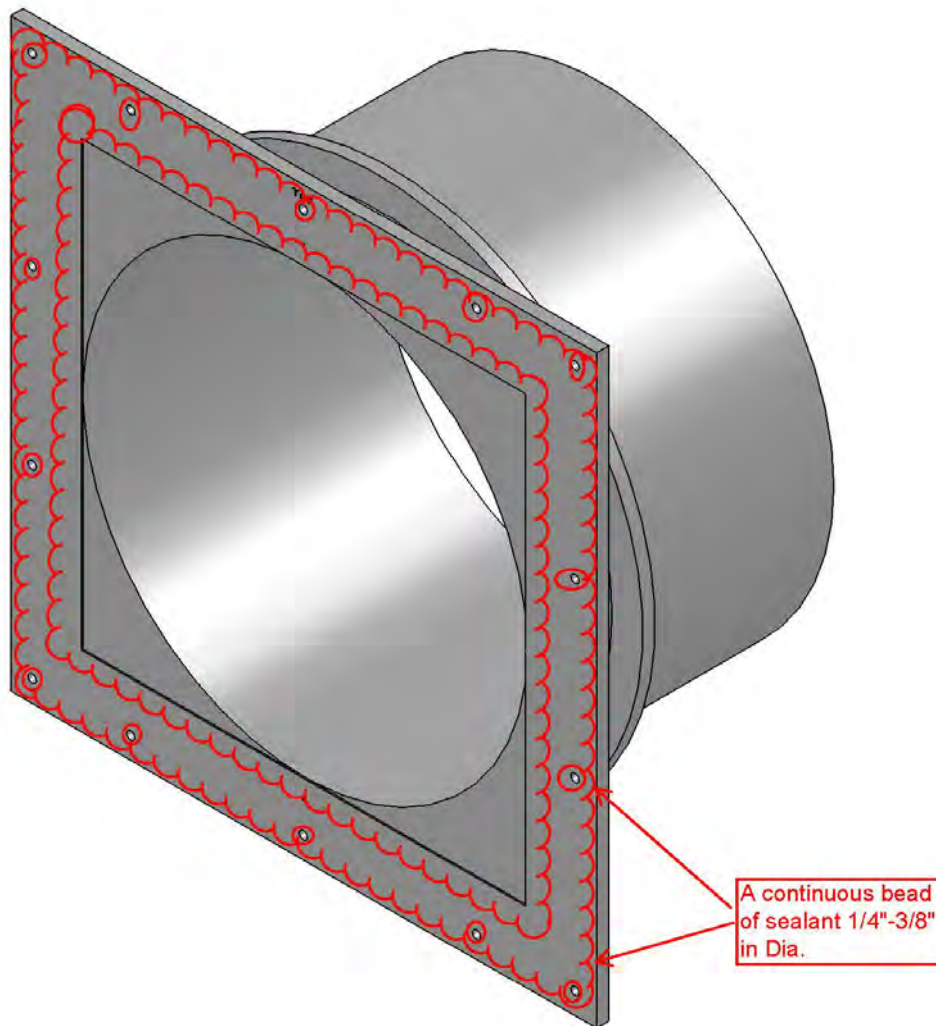

Correcting and Compensating for a Warped Thimble

If the vertical faces are out of parallel more than 1/32 inch, the thimble is warped or twisted excessively and the gate may exhibit sealing problems. Warping can be corrected in one of the following ways:

1. Remove thimble from concrete and try again. This requires substantial demolition and risks damage to the structure and thimble.
2. The preferred correction involves mounting the gate on the thimble with shims between gate and thimble flanges to restore gate seat faces to a good contacting condition. The resulting gap between gate and thimble flange can be sealed with mastic such as polyurethane seal-like Sika Flex 1-A.

There is a limit to how wide a gap the chosen mastic will seal. Consult the mastic supplier for gap limit and cure times. Sika Flex 1-A with Sika Flex primer claims to bridge and seal up to 1/2-inch gaps. Sika Flex 1-A requires a 1-week cure for water immersion; Sika Flex-2C NS/S1 requires a 3-day cure. Hydro Gate recommends not exceeding 1/4-inch gap with polyurethane considering uncertainties such as water pressure.

When the twist or warp exceeds 1/4 inch or operating heads are high (more than 20 feet of water), Hydro Gate recommends that the gap be filled with injectable epoxy to both form a watertight joint and provide a solid mounting for the gate. This work is best performed by an Adhesive and Sealing Contractor who can dam up the gap and inject the material.

The recommended steps to shim a gate frame are as follows:

- A. Dry mount the gate (i.e. without mastic.) If the gate has been wet-mounted with mastic, remove the gate and clean off all mastic, then dry-mount the gate. Do not tighten stud bolts.
 - B. Determine where and what thickness shims are needed between the frame and thimble, which will produce gate seat contact that excludes a .004-inch feeler gage. Shims may be stainless steel washers placed on stud bolts between the gate and thimble flange or "C"-shaped shims cut from stainless shim stock. Place the "C" straddling the stud bolts.
 - C. Tighten all stud nuts, then verify that the gate seat is contacting within .004 inch all around the opening.
 - D. Remove the gate, keeping track of what shims go where.
 - E. Apply a thick layer of mastic on the thimble or gate flange sufficient to seal the gap resulting from the shimming action or prepare for epoxy injection by Adhesive/Sealing Contractor.
3. If the thimble face is flat but is out of plumb, or racked, consult Hydro Gate's Engineering Department for suggestions. The axis of movement of the slide must be parallel to the axis of the stem within certain limits, depending on the gate size. Hydro Gate's Engineering Department can determine these limits for the specific installation and offer suggestions.

Installation of Flush Bottom Closure Gates

Gates that are to be installed with bottom frame members embedded in the concrete are furnished with a rubber seal attached to the invert of the gate frame (**Figure 4**). The top surface of the rubber seal is installed at the same elevation as the invert of the gate opening. Refer to the Hydro Gate installation drawing.

1. Form a recess for the bottom of the gate in the original pour of concrete. The dimensions of this recess are shown on the installation drawing.
2. After the forms are stripped, install the gate as shown for other types of installations in this Manual.

Figure 4 – View of Gate Slide and Invert Surface

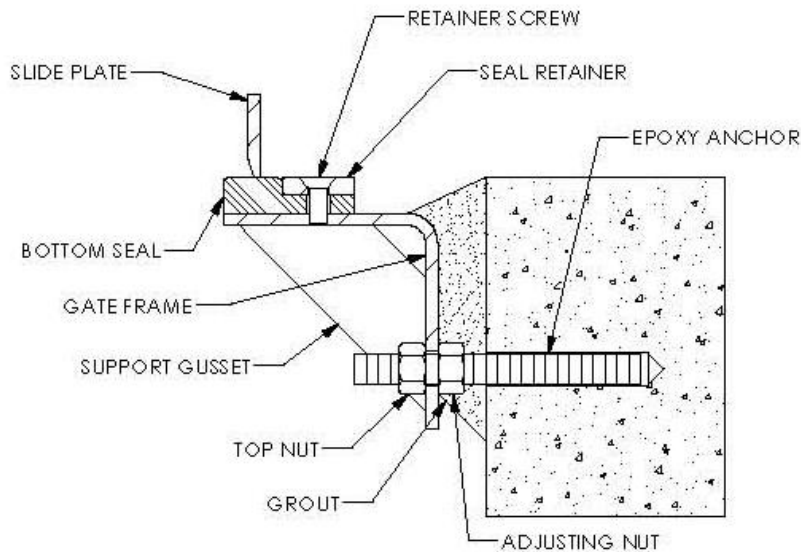

Gate Stem and Guides Installation

1. Install the stud bolts for the lift and stem guides as shown on the installation drawings. Check for proper alignment of the lift, stem guides, and gate. The lift stem and gate stem block must be in vertical alignment within 1/8 inch per each 10 feet of distance.
2. Provide opening with adequate clearance in the lift platform for the gate stem.
3. Install stem guide brackets on studs, but do not tighten nuts; leaving them loose so the bracket can be moved for later alignment. Loosen all assembly bolts holding the collars to the bracket. Stem guide collars are 2-piece construction.
4. When more than one gate is to be installed, stems may be of different diameters or lengths. Stems are marked and/or tagged for each installation. Separate the stems per individual gate installation.



Installation Note

Exercise care when handling and installing threaded stems; nicks or burrs will damage lift nut threads.

5. Insert the stem block into the gate slide pocket.
6. Stems may be in more than one piece to facilitate shipment and installation. If two or more pieces are furnished for an installation, they must be installed in their proper order from bottom to top to place splices in correct location so they will not interfere with the stem guides when the gate is opened or closed. Measure the stem section lengths and install.
7. Lower the bottom section of the stem into place through the hole of the gate slide and thread it all the way into the block and align the keyways (**Figure 5**).



Installation Note

Immediately insert the key to lock the bottom section of the stem to the block. (The key is omitted on non-rising stem gates as the turning motion is between the block and the stem.)

8. Place all of the succeeding stem sections. Double-check the installation drawings to ensure that the stem guide collars are in place. Join together with splices as provided (**Figure 6**).



Safety Note

Insert all bolts or keys in each stem splice immediately after sections are installed and aligned to prevent one section disconnecting from another when the gate is operated.

9. Immediately before lowering the lift over the threaded portion of the stem, remove the protective wrapping from the stem and thoroughly clean off all foreign material.
10. Lubricate stem threads with recommended lubricants. Do not leave lubricated stem exposed to contamination before completing the installation.

Figure 5 – Stem Connections to Gate

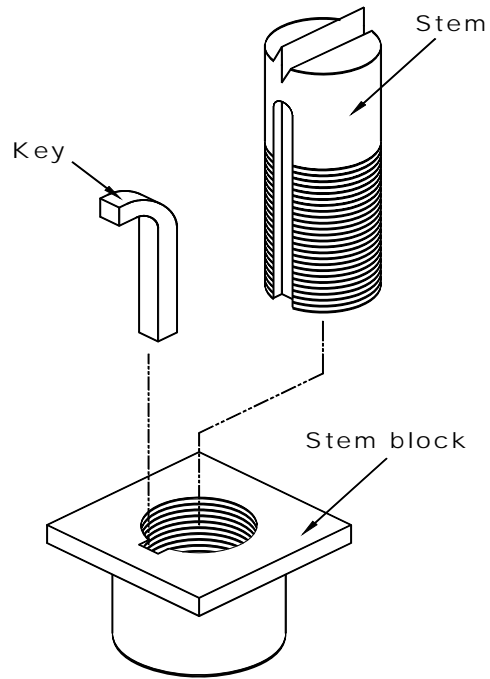
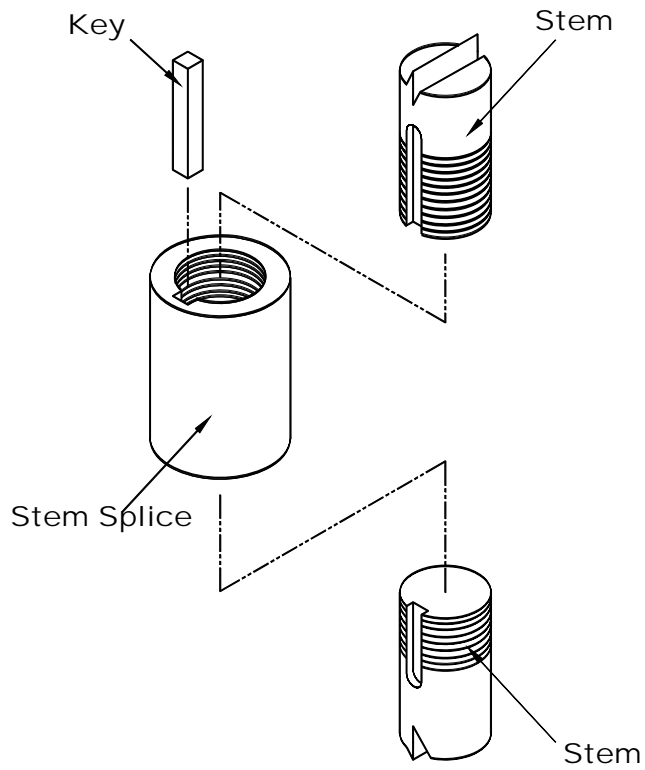

Figure 6 – Stem with Splice



Lift Installation and Adjustment of Stem Guides

1. Clean the threaded section of the stem, removing all foreign material, and lubricate with recommended lubricant as described in the "Gate Stem and Guide" section of this Manual.



Warranty Note: Operation of the gate assembly without proper lubrication of the stem will void the equipment warranty.

2. Raise the lift and lower it over the previously installed and lubricated threaded stem section. When starting threaded stem into the bottom of lift nut, care must be taken to avoid damage to the threads. Rough handling may result in damage to the bottom edge of the threaded lift nut and prevent the stem from being threaded into the lift nut freely. Hold the lift to prevent its rotation. Turn the handwheel or crank to lower the pedestal onto its stud bolts.

Installation Note: When all parts are cleaned, the threaded lift nut will turn onto the threaded stem with very little effort.

3. Using shims, double nuts on studs, or other leveling devices under the lift, align the centerline of the lift nut until parallel with the stem centerline. Vertical alignment of gate stem and the gate slide stem block must be within 1/8 inch per 10 feet of distance. Tighten nuts on the studs uniformly.
4. The crank should turn freely for two or three turns in each direction until the clearance between the top or bottom of the stem block in the gate slide is taken up. If any binding occurs during operation of the lift with the slight vertical movement of the gate slide, the stem alignment should be checked. Slight misalignment will cause undue wear to the threaded lift nut. When binding is not caused by misalignment, recheck to be certain all threads on the stem and in lift nut are clean.
5. Place the two-piece stem guide collars around the stem above each bracket. Place the bolts through the projection of the bracket and the ends of the collars. Do not tighten the bolts.
6. Grout under the lift (if required). After the grout has set, tighten the stud bolts uniformly.



Installation Note: Before opening the gate, clean all grout, stones or other foreign material from the top of the gate (or bottom in the case of a downward opening gate).

7. Turn the lift crank or handwheel to open the gate, until the gate slide has moved at least 2". The stem is now in tension. Check the stem to be certain it is straight. Tighten the nuts on the studs through the stem guide brackets, center the stem guide collars around the stem, and tighten the assembly bolts holding the collars in position on the brackets.
8. Move the gate to its fully opened position and check the position of the stems. If the stem is being deflected by the collars, a stem alignment problem exists and must be corrected, indicating the gate may not be plumb. Consult Hydro Gate for ways to correct or compensate for this condition.
9. Lower the gate to fully closed position. Run the stop nut down on top of the projecting threaded stem until it contacts the top of the lift nut or stem cover holder. Back the nut up until 1/16 to 1/8-inch gap appears between the lift and the stop nut to allow complete gate closure as sliding and bearing surfaces wear in.
10. Tighten the setscrews through the stop nut to hold it in place.
11. Install the stem cover, indicator, etc., as required.
12. Check to see if the gate slide is making full contact across the bottom invert seal.

Installation of Tandem Stems

Some gates have wide openings with relatively short gate heights. When the installation drawings show tandem lifts, install each lift in accordance with the preceding steps 1 through 5. After each lift has been installed and each stem is connected to the gate slide at the bottom and the lift at the top, proceed as follows:

1. Turn the input shaft of each lift in the direction to open the gate until each stem makes firm contact with the top of its connection on the gate slide.
2. Place a level on the top of the gate slide and move one stem or the other of the gate up or down until the slide is completely level.
3. A tandem interconnecting shaft is furnished to connect the two lifts and cause them to act in unison for raising or lowering the gate. Loosen the fasteners on one of the jaws of the flexible coupling and slide it toward the center of the shaft until the shaft can be connected between the two lifts. Complete the connection and retighten all fasteners.
4. Move the gate slide up and down by turning the input shaft of one lift. Ensure the gate is installed with its top level and that the gate is moving freely.
5. Complete the installation of any stem guides, lubricate the stem, adjust the stop nuts, etc, as described in the preceding steps 1 through 9 in the section entitled Lift Installation and Adjustment of Stem Guides for Gates Not Self-Contained.

Gate Adjustment

This gate is equipped with low-friction polyethylene (UHMWPE) seats and guides. The seats rest on a neoprene (rubber) pad for cushioned Gasketing to the frame. Sealing at the side is accomplished by pinching the seal lips against the slide plate using the compression of the rubber gasket pad. Top horizontal member seal (and also bottom, if standard bottom) are loaded by the compression pad and assisted with adjustable hook-type wedges on medium and larger width gates (**Figures 9 and 10**).

This gate has been factory adjusted. However, if the shake-proof nuts have been loosened, readjustment may be required.

Visual Tightness of the Seat against the Side

No light should be visible through the seat or measurable gaps between the slide plate and the seat. A .004 inch gauge may be used to check the seat gap as a starting point; however, the best test and proof of performance is an unseating hydrostatic test. This gate is required to comply with AWWA C561 leakage specifications.

Figure 9 – Top View of Side Section Seal Configuration

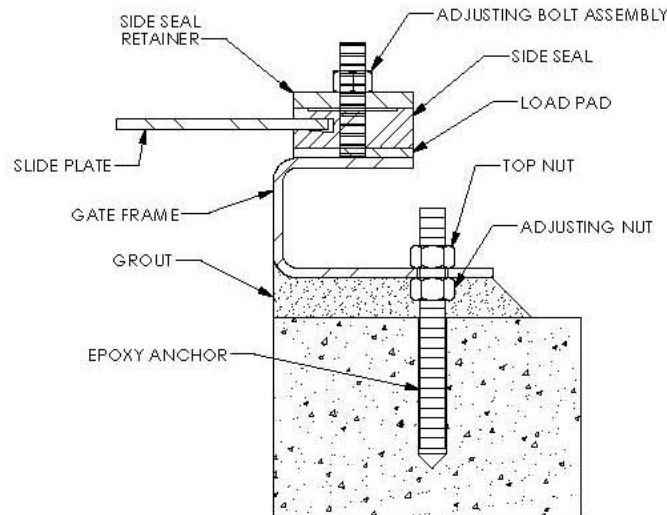
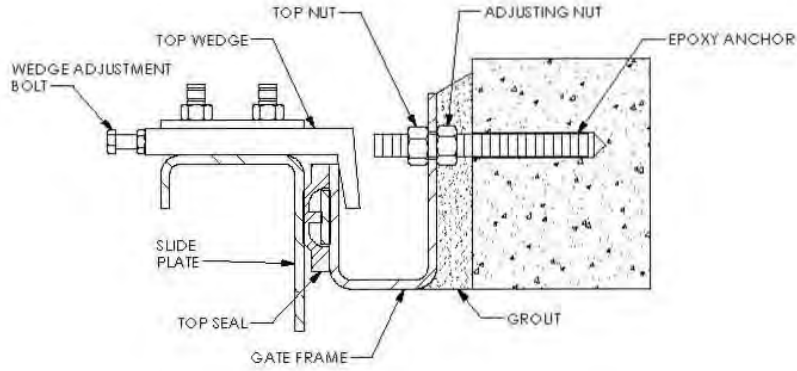

Figure 10 – Side View of Bottom Section Showing Seal Arrangement



Manual Lifts, Parts, and Assemblies

Typical assemblies of manual lifts are included for reference. These lifts may be either bench-mounted or pedestal-mounted. All Hydro Gate's lifts have housings that can be removed from the pedestal, leaving the lift nut in place supporting the gate weight. If inspection or service of the gears and bearings is necessary, unbolt the lift from the pedestal or benchstand and pull the housing off. The nut and retaining ring should stay in place.

Hydro Gate's lifts may be arranged in tandem. These lifts are connected with an interconnecting shaft, sometimes called a tandem shaft. See the gate installation drawing for more information.

The assembly of tandem lifts requires the following:

1. Reference is made to Hydro Gate's installation drawing.
2. Two stems are provided in two thread directions "left hand" and "right hand", refer to installation drawing for correct stem placement.
3. The stems and lifts are synchronized so that the gate lifts evenly.

Synchronization is accomplished with the interconnecting shaft coupling, (make up the coupling, per the installation drawing, when the gate and stems are even and level.)

(See Figure 11 or 12 for detail information)

Installation of Hydraulic Operating Cylinder, Stems and Stem Guides to Gate

The preferred method of installing and adjusting the operating cylinder to the gate is through the use of the hydraulic power system.

1. Ensure the gate slide is in the fully closed position. See appropriate sections for wedge and seat face check, and adjustments.
2. Locate the stem block/nut and clean the internal threads. Also, clean the threads on the cylinder rod thread and stem extensions where the nut will attach. Prior to final assembly thread the parts together to verify ease of assembly.
3. Bolt the cylinder to the operating platform as required. Prepare to connect cylinder rod to stem extensions as required per the installation drawings.
4. When more than one gate is to be installed, stems may be of different diameters or lengths. Stems are marked and/or tagged for each installation. Separate the stems per individual gate installation.

Installation Note

Exercise care when handling and installing threaded stems; nicks or burrs will damage lift nut threads.

5. Stems may be in more than one piece to facilitate shipment and installation. If two or more pieces are furnished for an installation, they must be installed in their proper order from bottom to top to place splices in correct location so that they will not interfere with the stem guides when the gate is opened or closed. Measure the stem section lengths and install.
6. Attach the upper most stem section to the cylinder rod. Join together with splices as provided (Figure 7).

Safety Note

Insert all bolts or keys in each stem splice immediately after sections are installed and aligned to prevent one section disconnecting from another when the gate is operated.

7. Lubricate stem threads with recommended lubricants. Do not leave lubricated stem exposed to contamination before completing the installation.
8. Place the anchor bolts for the stem guides as shown on the installation drawings. Check for proper alignment of the cylinder rod extension, stem guides, and gate. The cylinder rod extension and gate stem block must be in vertical alignment within 1/8 inch per each 10 feet of distance.
9. Install stem guide brackets on anchors, but do not tighten nuts; leaving them loose so the bracket can be moved for later alignment. Loosen all assembly bolts holding the collars to the bracket. After each collar is installed, re-bolt it to its bracket, but do not tighten.

10. Connect the hydraulic lines to the appropriate port on the cylinder. Refer to the operation and maintenance manual for the hydraulic system.

Installation Note

Take care to not leave the cylinder ports uncovered during installation as contaminants can enter the hydraulic system causing premature failure.

11. Supply hydraulic fluid to extend the cylinder rod and stem assembly toward the gate slide stem block pocket. If the cylinder rod does not align with the center of the stem block pocket it will be necessary to make adjustments to the cylinder mounting.
12. Place the stem block/nut in the gate slide stem block pocket. Refer to the installation drawing provided to confirm the correct location.
13. Carefully extend the rod and stem assembly into the block pocket and rotate the stem block/nut to engage the threads.
14. The stem block/nut will have multiple holes in its circumference. A straight piece of rod can be used to rotate the nut.

Installation Note

The cylinder must be fully extended, at the same time the gate must be completely closed. Care must be taken not to over close the gate which creates distortion across the top of the gate slide.

15. Alternately extend the cylinder rod and rotate the nut until the cylinder rod is fully extended. Verify that the cylinder rod or stem extension thread fully engages the stem nut, and the nut is in contact with the bottom of the block pocket.
16. Tighten the screws that lock the stem block/nut to the matching rod and stem assembly.
17. Bleed the hydraulic lines to remove trapped air. Refer to the operation and maintenance manual for the hydraulic system.
18. Cycle the gate several times to verify proper function.
19. Re-check with feeler gauge across the top of gate opening. Verify that the cylinder is not over-closing the gate, causing the slide to bend open at the stem block pocket. Back up the stem block slightly on the rod to alleviate this problem.

OPERATION

General Operation Information

HG561 Fabricated Stainless Steel Gates are used to control flow of or retain a volume of water, effluent, or other fluids. Typical applications include industrial water treatment facilities, municipal water treatment facilities, irrigation, dams, flood control, and many other applications that require tight, low leakage closing.

The simplicity of a slide gate makes it a popular choice when designing flow controls. From the basic hand-cranked manual model to the microprocessor-controlled, fully integrated electric slide gate, actuation consists of the basic open or closed operation. An open gate allows flow and a closed one does not.

Depending on size, most slide gates can operate without error in diverse conditions. Some extenuating circumstances may include large amounts of ice or other solids that will obstruct the travel path of the gate. In most cases, when the obstruction is removed, normal operation can be resumed without adjustment to the gate.

Slide Gate Operation Procedures

The following sections cover the general operating procedures associated with two manual-operation systems (handwheel and handcrank). Read and follow the operating procedures for the applicable system.

If you have any questions concerning safe operation of this HG561 Fabricated Stainless Steel Slide Gate, contact Hydro Gate immediately.

HB Series Actuator (Manual Handwheel or Tee Wrench)

Opening – To open this Cast Iron Slide Gate observe the direction of rotation noted on the handwheel. Turn in the direction of opening. If the gate has been closed for an extended period the gate may be difficult to “unseat.” If, after several turns of the wheel, the rotation becomes increasingly difficult stop rotation when a **moderate** pressure is achieved. Allow the pressure in the stem to unseat the gate (a “POP” sound typically signals the gate has begun to travel. Continue to turn the hand wheel until the desired gate position has been achieved. Observe the relative position of the top of the stem in relation to the Mylar decal on the stem cover (if equipped.) When the top of the stem is equal to the OPEN or 100% indicator the gate is considered to be FULL open and should not be opened further.

**Operation**

Do not over-open the gate. Serious damage to the gate stem and sealing surfaces can result.

Closing – To close this Cast Iron Slide Gate turn the handwheel in the direction opposite of the Open indicator until the stopnut on the stem has **moderately** seated on the top of the lift. When the top of the stem is equal in height to the bottom/zero height indicator, the gate is considered to be FULL CLOSED and should not be closed further. Should the gate or stop nut require adjustment, refer to the appropriate section of the Installation, Operation, and Maintenance Manual or call Hydro Gate **before** any adjustments are made.

**Operation**

Do not attempt to adjust the position of the stopnut to achieve additional closing stem travel. Serious damage to the gate stem and sealing surfaces can result.

CPS Series Actuator (Manual Handcrank)

Opening – To open this Cast Iron Slide Gate observe the direction of rotation noted on the lift housing. Crank in the direction of opening. If the gate has been closed for an extended period the gate may be difficult to “unseat.” If, after several turns of the handcrank, the rotation becomes increasingly difficult stop rotation when a **moderate** pressure is achieved. Allow the pressure in the stem to unseat the gate (a “POP” sound typically signals the gate has begun to travel. Continue to turn the handcrank until the desired gate position has been achieved.

**Operation**

Do not over-open the gate. Serious damage to the gate stem and sealing surfaces can result.

Closing – To close this Cast Iron Slide Gate turn the crank in the direction opposite of the Open indicator until the stopnut on the stem has **moderately** seated on the top of the lift. After the gate has been closed as noted on the indicator, the gate is considered to be FULL CLOSED. Then reverse the rotation of the crank and relieve the pressure on the stem and lift. Should the gate or actuator require adjustment, refer to the appropriate section of the Installation, Operation, and Maintenance Manual or call Hydro Gate **before** any adjustments are made.

**Operation**

Do not attempt to adjust the position of the stopnut to achieve additional closing stem travel. Serious damage to the gate stem and sealing surfaces can result.

MAINTENANCE

Maintenance and Lubrication

Occasional adjustment and lubrication of Hydro Gate slide gate components will be required. The frequency will depend upon how often the gate is used, location, and operating conditions. Periodic inspection, adjusting, and cleaning are recommended as conditions at the site permit.

Lift and Stem Maintenance

Maintenance of the threaded operating portion of the gate stem is critical and should be performed as frequently as the operating environment requires.



Failure to maintain stem thread lubrication causes operating difficulties and premature failure of the lift nut and stem threads.

Recommended inspection frequency and procedures are listed on the maintenance schedule:

- Initial inspection at the time of installation and again at the date of commissioning.

A “cycle” of gate operation is operation of the gate slide from closed to open to closed position. At each inspection, verify the following items:

- Inspect the stem threads and lift nut threads for wear and verify the trueness and dimension of the thread form. See wear checking procedure.
- Check the amount and condition (diary and day) of lubricant remaining and add if necessary.
- Relubricate if necessary - threads should be cleaned and relubricated with fresh lubricant.

More severe conditions or operating modes require a slightly different schedule of inspection and service. For example: Modulating gates with electric motor operators may make position changes several times a day but seldom go full stroke. There is a portion of the stem that gets a lot of use. These stems should be inspected at least weekly. The lubricant on the stem threads should be monitored closely. As the lubricant is depleted and becomes contaminated, it should be cleaned and replenished.

When excess dried grease or other foreign material is carried into the threads of the lift nut, extremely hard operation will result. If serious binding occurs, the only way to correct it is to remove the threaded stem from the lift nut and clean the thread interior. If this foreign material is not cleaned from the interior threads of the lift nut, heavy pulls on the handcrank or seizure will result.

Stem threads may be cleaned with solvent, rags, and brushes. Run the gate open. While in the process of opening (running the stem out above the lift nut), clean off the old grease. Inspect the threads for roughness. If the threads are rough, they may be filed and polished. Be careful to keep filings and grit out of the lift nut. Rough stem threads accelerate the wear of the lift nut threads.

Relubricate stem threads by brushing or smearing grease onto/into the threads as the gate is closing (the stem is going into the lift). This puts fresh lubricant into the lift nut and carries out the old contaminated grease. It is recommended that the contaminated grease be cleaned from the stem as it exits underneath the lift where the stem is accessible from below. Replenish grease on the underside stem.

The recommended stem thread lubricant is a mixture of "La Co Slic-Tite Paste" and Fiske Bros. "Lubriplate No. 630 AAA" in the ratio of 24 ounces of paste per gallon of grease. "Slic-Tite Paste" is a pipe dope with Teflon fibers and is available from most plumbing supply stores or from:

La Co Industries, Inc.
1201 Pratt Blvd.
Elk Grove Village, IL 60007
(708) 956-7600

An equal alternate for La Co's "Slic-Tite" is "Dayton Pipe Thread Sealant Paste with Teflon", Stock Nos. 4X222 or 5X998, which is available at W. W. Grainger Inc. stores in major cities nationwide.

Equivalent lubricants to Fiske Brothers' "Lubriplate 630AAA" include:

Conoco's "All Purpose Superlube"
Texaco's "Multi Fak Heavy Duty No. 2"
Shell Gadus Grease (formerly known as Alvania grease)
Mobil's "Mobilux EP2"
BP Energrelse LS 2
Fiske Brothers' "Lubriplate No. 630 AA"

Recommended for potable water is a vegetable-based lubricant, "Lubriplate Super FML 2".

Lifts may be furnished with a stem lubricator Zerk Fitting which is located in the "stem cover adapter" to facilitate lubrication of stem threads with pressure greasing equipment. To be effective, lubricant should be injected while the stem is moving through the lift.

Manual crank lifts have sealed thrust bearing and do not require lubrication.

Exercise of infrequently operated lifts and gates is recommended. An annual exercise will ensure the gate is operable when needed and the lubrication condition will be maintained.

Removal of the stem nuts for thread inspection or check with the wear checking procedure of frequently modulated gates is recommended. This avoids "surprise" when the nut threads have worn so thin they strip out and drop the gate. Replacement or spare nuts can be ordered from Hydro Gate. Spare parts are usually not needed or recommended, because they are readily available on short notice from Hydro Gate. In those cases where equipment operation or downtime is critical and the gate is operated extremely often, a spare lift nut may be wise to have on hand.

**Maintenance Schedule and Lubrication Summary
HG561 Fabricated Slide Gates and Manual Lifts**

| Activity | Frequency | Lubricant |
|---|---|--|
| General Cleaning and Inspection | As often as conditions require or permit, or every 6 months. | N/A |
| Stem Thread and Lift Nut Wear Inspection | Initial inspection after 10 cycles. Subsequent inspection after 25 cycles. Operational inspection after each 50 cycles, or every 6 months. | N/A |
| Stem Thread Lubrication and Cleaning Inspection | Every 3 months, quarterly or 6 months. Clean grease if dried or contains foreign material every 6 months. | Mixture of 24 fluid ounces La Co Slic-Tite Paste and 1 gallon of Fiske Bros. Lubriplate No. 630 AAA or AA. (An equal alternate is Dayton Pipe Thread Sealant Paste with Teflon, Stock Nos. 4X222 or No. 5X998) |
| | Equivalent lubricants to Fiske Bros. Lubriplate No. 630 AAA or AA include the following: Conoco's All Purpose Superlube Texaco's Multi Fak Heavy Duty No. 2 Shell Oil Company's Alvania No. 1 Mobil's Mobilux EP2 Exxon's Ronex MP | |
| <p>Notes</p> <ul style="list-style-type: none"> • <i>Inspect crank lift, and/or electric actuator for the collection of moisture beneath the stem cover housing. Unthread the stem cover housing and examine the space surrounding the stem. A convenient method of removing the moisture is by utilizing a Squeeze Bulb, Siphon or Baster.</i> • For potable water treatment plants use a vegetable-based lubricant such as Lubriplate Super FML-2. • La Co Slic-Tite Paste is available at plumbing supply stores or from La-Co Industries, 1201 Pratt Blvd., Elk Grove Village, IL 60007 (847) 956-7600. | | |

Lubrication Equivalents

Hydro Gate considers any of the following greases/lubricants to be acceptable:

- A. Fiske Brothers "Lubriplate" No. 630 AAA or AA
- B. Sta-Lube "Sta-Lube" No. 3121
- C. Conoco "All Purpose Superlube"
- D. Texaco "Multi Fak Heavy Duty" No. 2
- E. Shell Gadus Grease (formerly known as Alvania)
- F. Mobil "Mobilux EP2"
- G. BP Energrease LS 2

Hydro Gate recommends the following pipe thread sealants with Teflon:

- A. La-Co Slic-Tite Paste
- B. Dayton Pipe Thread Sealant with Teflon\
- C. McMaster-Carr Pipe Thread Sealant with Teflon
- D. Any other commercially available pipe thread sealants containing Teflon.

For potable water treatment plants, Hydro Gate recommends using a vegetable-based lubricant such as:

- A. Lubriplate Super FML-2.
- B. Rocol Foodlube Multi-Paste (European product)
- C. Petro-Canada Purity-FG

Interchangeable

Leakage

The most frequent cause of excess leakage through a newly installed gate is improper installation and/or failure to make final adjustments to the gate before operation. When you encounter this problem, first verify that Hydro Gate's installation instructions have been carefully followed and that final adjustments and greasing have been accomplished. If not, then follow step-by-step the adjustment procedures as outlined in the appropriate instructions.

Another important check is to ensure the gates were not disassembled for installation. The outside of our installation booklet states, "**DO NOT DISASSEMBLE GATE FOR INSTALLATION**". This is repeated in the text of this Installation, Operation, and Maintenance manual at several critical locations. Occasionally, we still find that gates are disassembled for easier handling, painting, etc. When it is absolutely necessary to partially disassemble a gate or remove the slide to facilitate installation, use extreme care in handling the parts, particularly the frame. As pointed out above and in our installation instructions, the amount of leakage through the gate is highly dependent upon the quality of the installation.



Without the slide in place, the frame is very fragile. Hydro Gate cannot be responsible for performance problems caused by rough handling and damage to gate parts.

AWWA C561 standards for Heavy Duty Fab. Gates are 0.1 gallons per minute per foot of seating and unseating perimeter. A correctly installed and adjusted HG561 Fabricated Stainless Steel Gate can usually perform at $\frac{1}{4}$ of the AWWA seating leak rate.

Troubleshooting Tips

Most fabricated slide gates depend on water pressure with a slight deflection of the gate slide to seal. Proper installation and cleaning of seating faces are still necessary for the gate to be as watertight as possible.

Excessive Localized Leakage

Check by opening the gate slide to its FULL UP position. Use thin wire, string, or straight edge to check the gate frame. Stretch the wire along each side. If there is significant (1/32 inch or more) variation in the seating face, excess leakage will result in those locations where warpage has occurred. Also, stretch the wire corner-to-corner across the opening. If the strings do not touch at the center, then one corner, or the other, has been pulled back considerably from the plane. To repair this faulty installation, it is necessary to loosen bolts, push the frame out as required and align it before tightening or regrouting.

Dirty Seating Faces

Excess leakage can also be caused by foreign material on seating faces of the gate frame or slide. Check for drops of paint, cement runs on seating faces, or other construction grime. To correct, remove foreign material from the perimeter of the seating faces on both slide and frame, and reseal the gate.

Excessive Leakage near Top of Slide

If leakage occurs primarily at the top near the stem, there is probably excess compression in the stem, which is pulling the gate slide from its frame. Check by turning the handwheel or handcrank in the direction to open the gate. When excess pressure on the stem is removed, the slide will spring back into position. Reset the top nut, or adjust the torque or limit switches as described in No. 8 of this section.

Excessive Leakage near Top of Slide, Frame Not Warped

If leakage occurs primarily at the top and the slide is not warped or pushed out of position, then ensure the top frame member is not pulled against the concrete. This is most likely on gates wide enough for expansion studs in the top frame member. To correct misalignment, loosen the bolts into the cinch studs and shim behind the top frame member to push it away from the concrete. Use a straight edge or thin wire stretched along the upper frame member to set the member straight. Check seal contact or fit with the slide before regrouting. This space may also be packed with polyurethane sealant or epoxy grout.

Leakage across Bottom of Flush Bottom Gates

If a sheet of water is coming from the bottom of the gate, the gate is not completely closed. To completely close the gate, the stop nut or limit switch may need to be reset. When properly closed, the slide will be embedded approximately 1/16 inch into the flush bottom seal and neither a .005-inch to .015-inch gauge will fit between the flush bottom seal and the bottom of the slide. Use of a flashlight or a trouble light on the opposite side will also indicate if good contact is being made.

Excessive Leakage through Seats Top and Sides

This indicates that either the cover bar or hook wedges are too loose or the gate has damaged seats. For the loose fitting components simply re-tighten and for the damaged seats attempt blending localized damage; tighten adjustment nuts and wedges; replace seats and carefully fit and seal the joints.

Stem Bends when Gate Is Closed***Hand-Operated Lifts***

1. Ensure stem guide collars are properly located to hold the stem in alignment. Bolts on collars must be tightened so the collar is not slipping on the guide bracket.
2. Ensure stem guides are all located properly. If the spacing exceeds that shown on the installation drawing, the stems may be deflecting before the gates are tightly closed.
3. If stem guides are correctly located and collars are tight, then the load being applied to the stem by the lift is in excess of that needed to close the gate, or the load recommended for a particular stem size. Reset the stop nut to prevent an excess load from being applied to the stem after the gate is closed.

Excess Force Is Required on Handwheel or Crank

1. Ensure the stem is lubricated as recommended.
2. If a simple application of lubricant does not appear to solve the problem, check for foreign material jammed in the nut threads by either disassembly or working back and forth with generous application of penetrating oil and grease.
3. If the stem is properly greased and the lift nut does not appear to be dirty or binding, ensure the stem, stem guides, and lift are in proper alignment. On most installations, the stem will be installed in the vertical position. A carpenter's level can be used to verify that it is in vertical plane in both directions. Check for binding through individual stem guides. Check the pedestal to ensure it is vertical in both directions and the stem threads are straight through the lift nut.
4. In locations where the stem is not installed vertically, such as on the face of a dam, alignment can be checked using a thin wire stretched tightly between the top of the slide and the bottom of the lift. Realign by adjusting the stem guides and/or shimming one side of the lift as required.
5. Check the frame guide grooves. Remove any foreign material. Check tightness of rubber seals. Loosen if necessary. Reposition or replace if rolled over, torn, or wadded up.

Long-Term Storage Instructions for HG561 Fabricated Gates, Lifts, Stems and Accessories

1. Gate assemblies shall be stored horizontally and flat, with the back side (flange side) down. The storage area must be flat, graded, comprised of compacted soil, concrete, or asphalt.
2. Place timber, minimum 4 inch x 4 inches, to provide substantially complete perimeter support under the gate frame assembly. Longitudinal timbers, spaced a maximum of 4 feet, may also be used.
3. Stacking of gates is permissible. The stacked height should not exceed 3/4 of the bottom gate's width or height. Stack gates of different sizes in a pyramid fashion. Do not stack large gate on top of smaller gates.
4. Stacked gates should be separated with timber. The separating timbers should form a flat and level base for the gate above.
5. Wall thimbles may be stored similar to above. They may be stored with machined flange face up or down. Substantial level blocking is essential. Uneven support of gate assemblies and thimbles causes the gate or thimble to warp and voids the manufacturer's warranty.
6. Store the lift assemblies either upright with plastic plugs/caps in place to keep dirt out of the nut threads or leave in original shipping cartons. Do not store the lifts directly on the ground.
7. Stems and stem covers should be stored horizontally on timbers spaced 4 to 8 feet apart. Protective sleeves should be left on all stem threads and stem covers.
8. Miscellaneous accessories and hardware should be stored off the ground.
9. Bronze stem blocks, wedges, lift nuts, and stainless steel accessories are targets for theft and resale as scrap. Report all shortages at once and note on shipping papers. Hydro Gate cannot be held responsible for theft and loss of equipment stored on the job site.
10. Inside dry storage is the best for all equipment. Covering equipment stored outside with tarpaulins is recommended to minimize degradation of paint from rain and sunlight, until finish paint is applied. Uncovered outdoor storage may result in staining of painted surfaces from rain and sunlight.

WATER CONTROL GATE GUARANTEE

Hydro Gate's standard warranty applies to this order, and can be found at
www.hydrogate.com/support

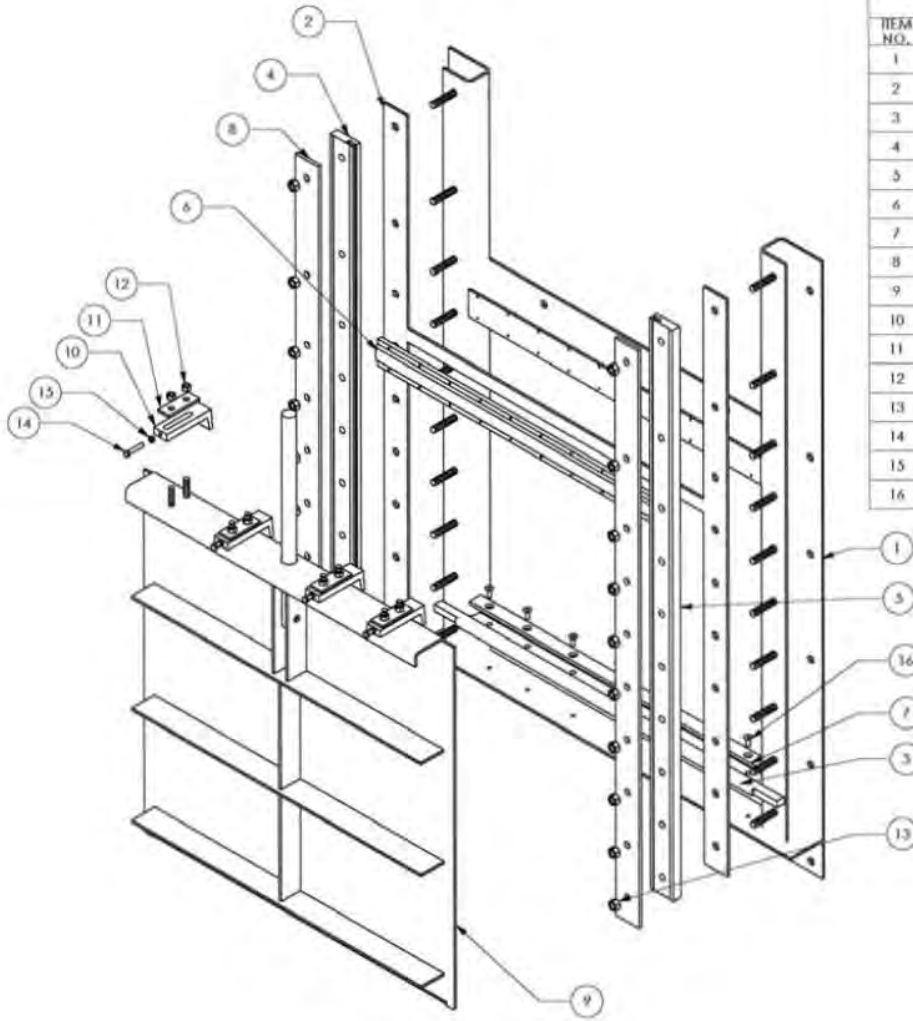

| BOMTable | | |
|----------|--|--------------|
| ITEM NO. | DESCRIPTION | Default QTY. |
| 1 | FRAME WELDMENT-STAINLESS STEEL | 1 |
| 2 | LOAD PAD-NEOPRENE | 1 |
| 3 | SEAL, BOTTOM-NEOPRENE | 1 |
| 4 | SEAL, LEFT SIDE-UHMW | 1 |
| 5 | SEAL, RIGHT SIDE, UHMW | 1 |
| 6 | SEAL, TOP-UHMW | 1 |
| 7 | RETAINER, SEAL, BOTTOM-STAINLESS STEEL | 1 |
| 8 | RETAINER, SEAL, SIDE-STAINLESS STEEL | 2 |
| 9 | SLIDE WELDMENT-STAINLESS STEEL | 1 |
| 10 | WEDGE, TOP | 4 |
| 11 | PLATE, WASHER, TOP WEDGE | 4 |
| 12 | NUT, HEX, LOCKING, 1/2-STAINLESS STEEL | 8 |
| 13 | NUT, HEX, LOCKING, 5/8-STAINLESS STEEL | 20 |
| 14 | BOLT, HEX, 3/8X2 LONG-STAINLESS STEEL | 4 |
| 15 | NUT, JAM, 3/8-STAINLESS STEEL | 4 |
| 16 | SCREW, F/H, 3/8 X 1-STAINLESS STEEL | 7 |

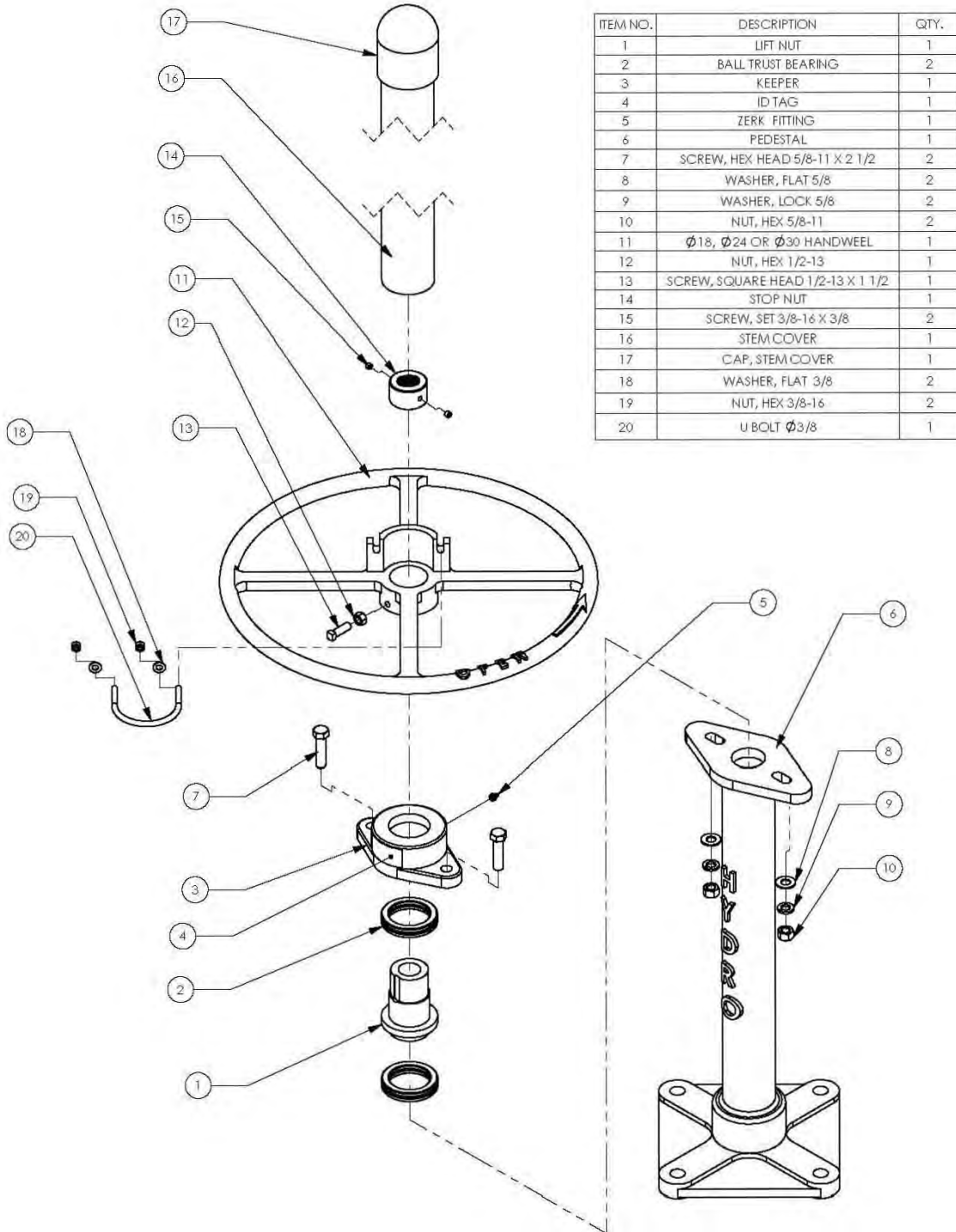

Figure 11 - Manual Handwheel Model H2B

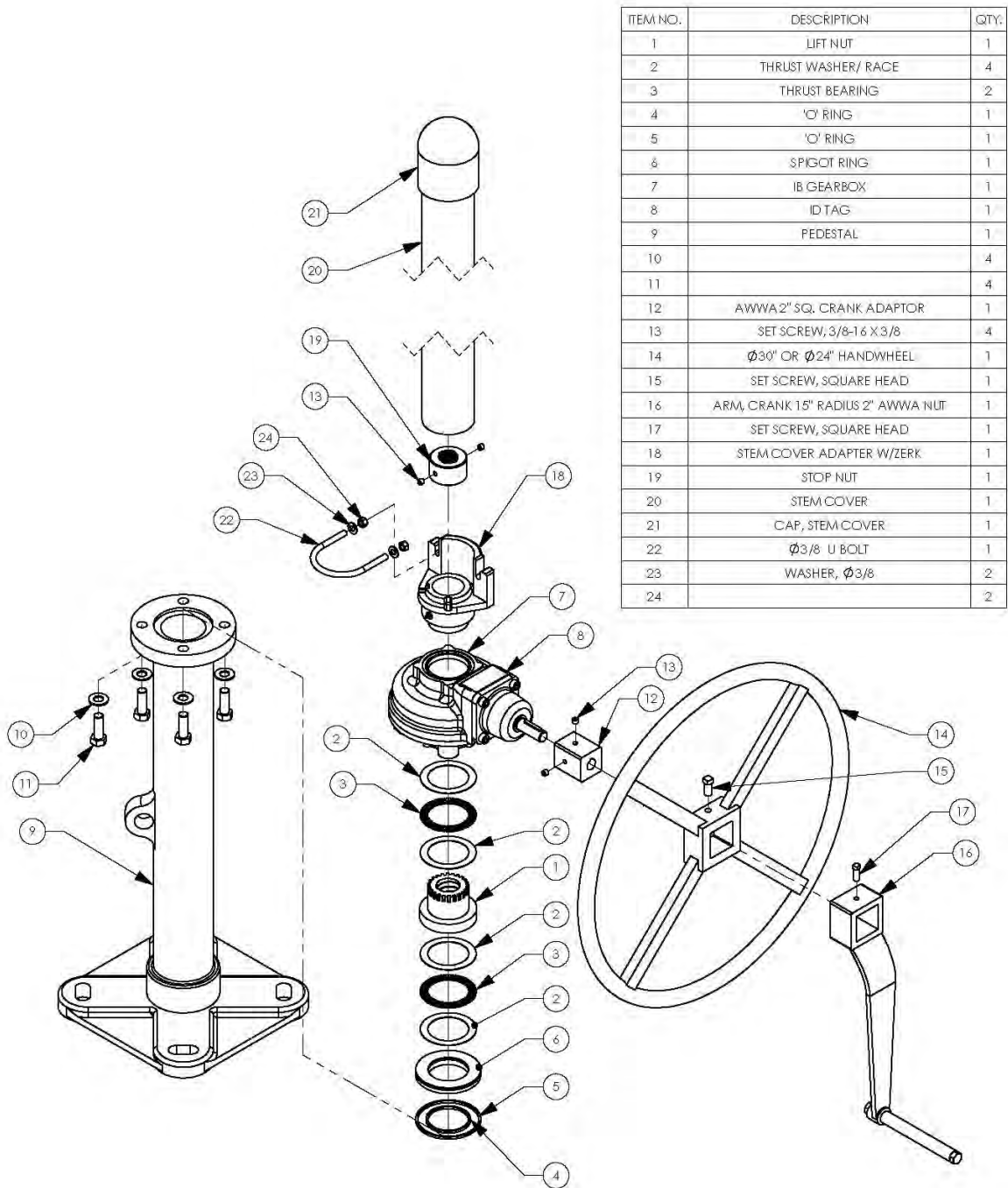

Figure 12 - Manual lift Type IB

SPARE PARTS

- Check size of parts before attempting to store them
- Spare parts should be stored in clean, dry and protected warehouse until ready for installation.

HOW TO ORDER REPLACEMENT OR SPARE PARTS

Parts may be ordered from your local Hydro Gate Representative or direct from Hydro Gate.

Please have the following information:

1. Hydro Gate sales information found on the blue anodized tag located on the gate or pedestal.
2. The item and/or tag number must be relayed to Hydro Gate
3. Description of replacement Part(s)

Spare Parts List

| | |
|---|------------------------------|
| 1 | Stop Nut |
| 2 | Stop Collar |
| 3 | Lift Nuts |
| 4 | Stem Cover |
| 5 | Thrust Bearing for Gate lift |

Table 1

DATE: 6-7-18 BY: Lee Cooper

- NO EXCEPTION TAKEN
- MAKE CORRECTIONS NOTED
- REVISE & RESUBMIT
- REJECTED

This shop drawing review is for general conformance with contract documents only and does not relieve the contractor of his responsibility for compliance with requirements of the drawings and specifications.

CITY OF GRAND JUNCTION
COLORADO

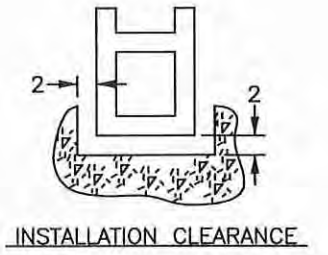
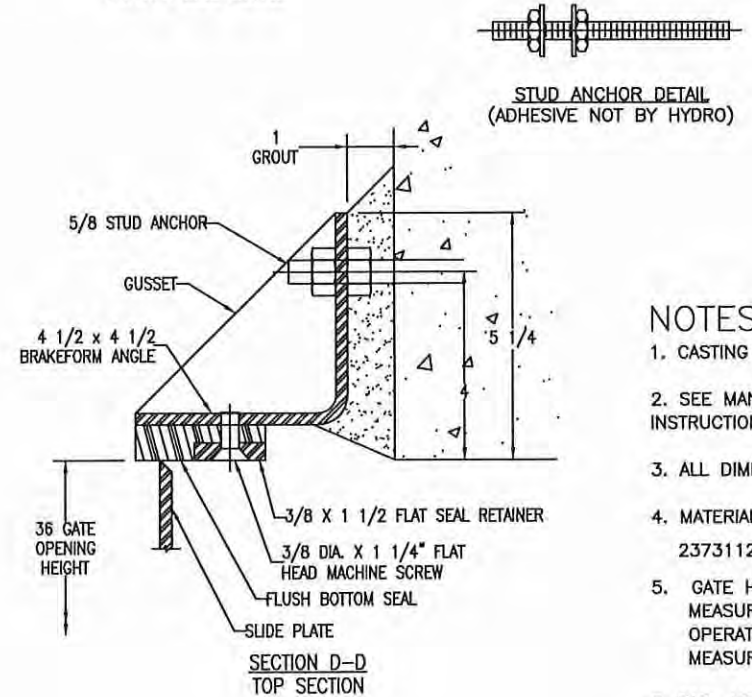
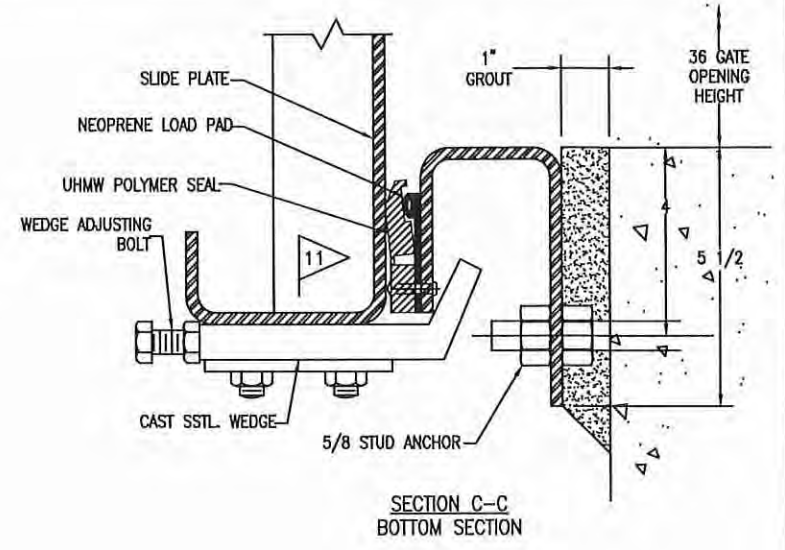
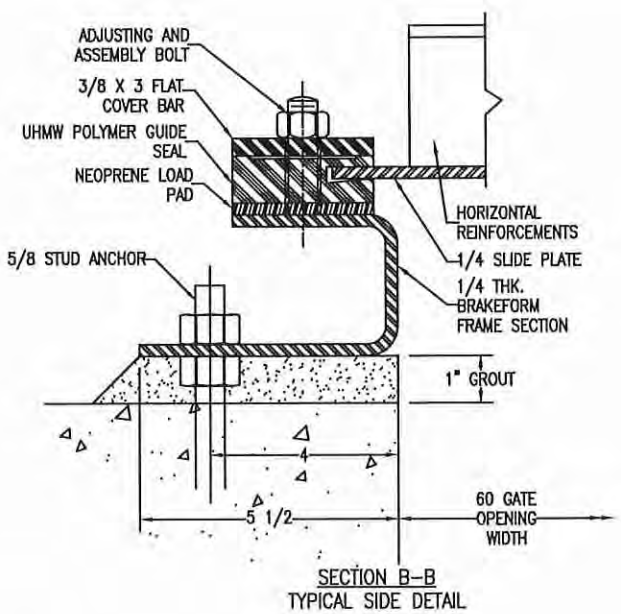
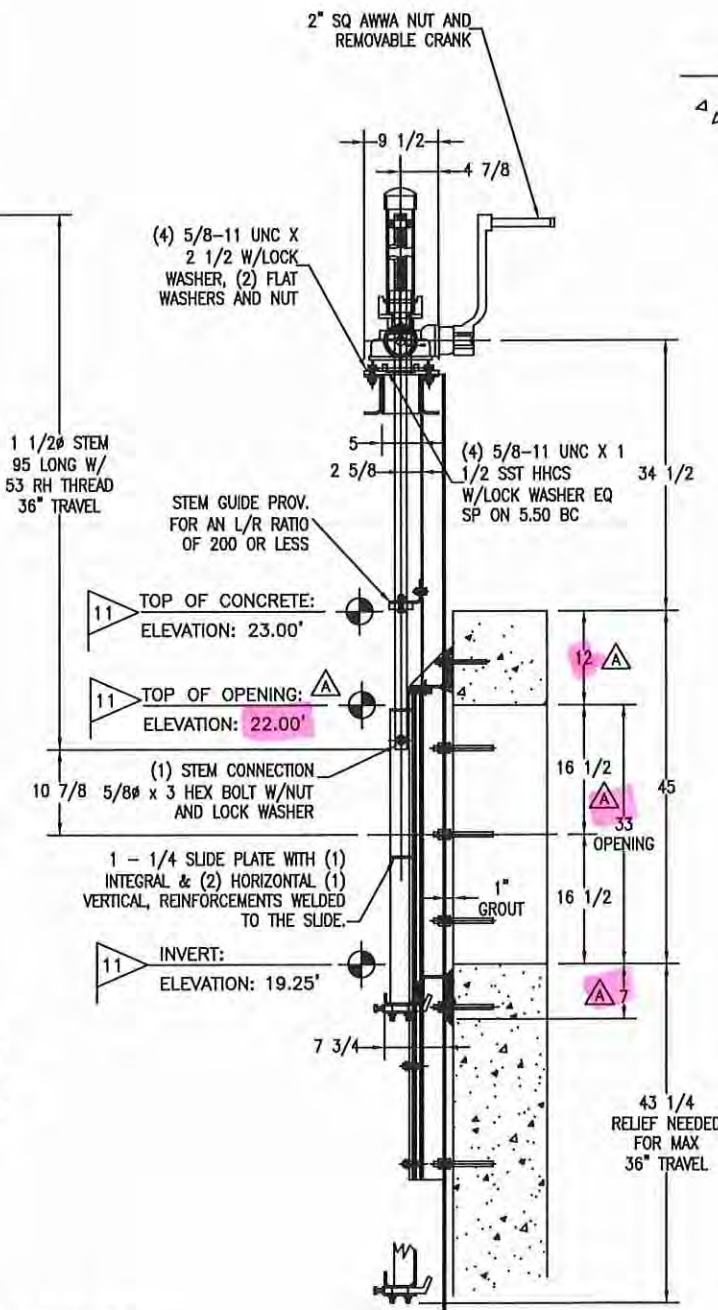
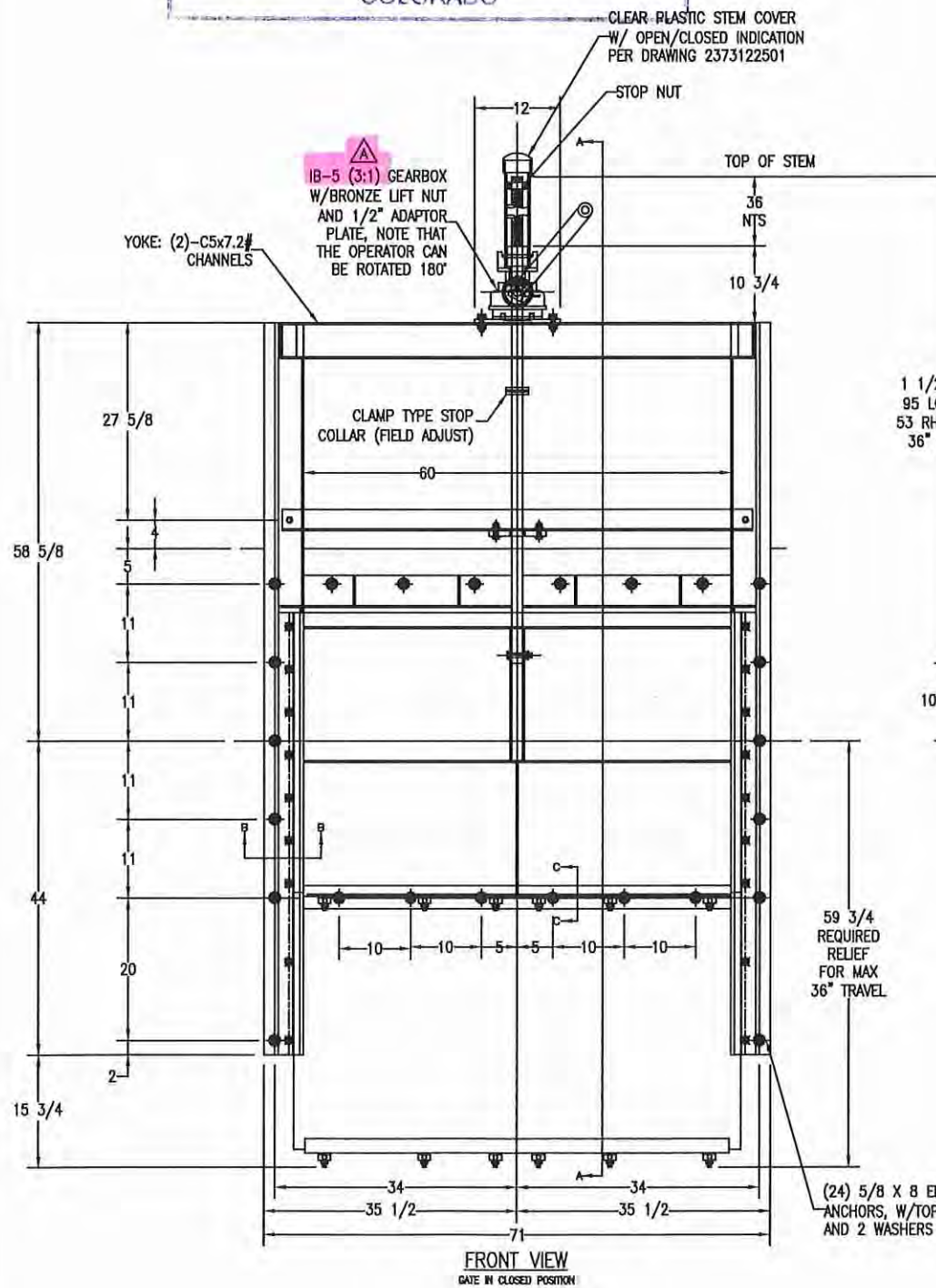

- NOTES:
- CASTING TOLERANCES APPLY ON ALL UNMACHINED SURFACES.
 - SEE MANUAL G2500 FOR INSTALLATION AND ADJUSTMENT INSTRUCTIONS
 - ALL DIMENSIONS IN INCHES UNLESS OTHERWISE NOTED.
 - MATERIAL SPECIFICATIONS AND COATINGS PER DRAWING: 2373112500
 - GATE HEAD DESIGN SEATING: 2.25'
MEASURED FROM GATE UNSEATING: 2.25'
OPERATING DESIGN HEAD SEATING: 2.25'
MEASURED FROM GATE UNSEATING: 2.25'
 - TAG: HG1 60X36, HG2 60X36, HG3 60X36, HG4 60X36
 - ENGINEER: CITY OF GRAND JUNCTION
 - LOCATION GRAND JUNCTION, CO
 - REFERENCE SPECIFICATION SECTION: IFB-4503-18-DH
 - REFERENCE PLAN DRAWINGS: CONTROL STRUCTURE NO1, 2, &3
- PLEASE CONFIRM THE GATE SIZE & TRAVEL, THE TOP OF CONCRETE AND INVERT ELEVATIONS, AS WELL AS THE INVERT CONFIGURATION.

| | | | |
|-------------------|---------------|--|------------------------|
| HYDRO GATE | | 60" X 36" MODEL HG561 WEIR GATE | |
| | | WALL MOUNTED, SELF-CONTAINED, RISING STEM, TOP SEAL | |
| QUANTITY: 4 | | MATERIAL: 316 SST | |
| SCALE: 1"=3/5" | | THIS IS A PROPRIETARY DESIGN OF HYDRO GATE, LLC. THE DESIGN, DATA AND INFORMATION RELATING THERETO IS NOT TO BE USED, DISSEMINATED OR REPRODUCED IN WHOLE OR IN PART WITHOUT THE EXPRESS WRITTEN CONSENT OF HYDRO GATE, LLC. | |
| REV. A | DATE 06/06/18 | INITIALS QP | |
| DRAWN BY QP | | CUSTOMER NO. 2018-00000292 | SALES 2373112 |
| CHECKED BY | | DATE 05/22/18 | DRAWING NO. 2373112-01 |

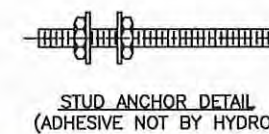
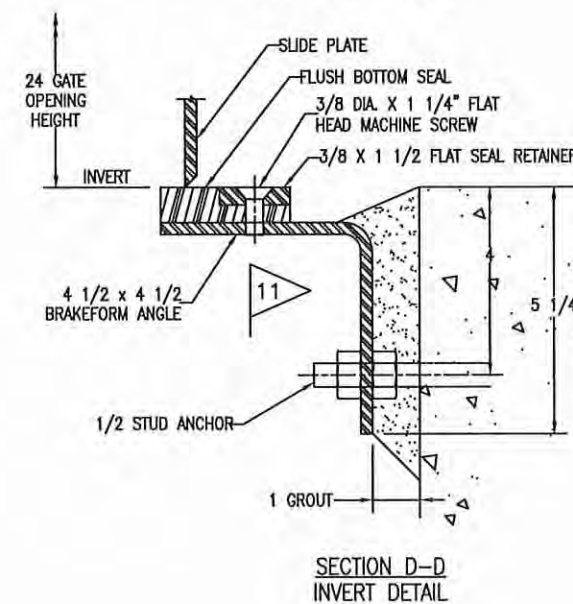
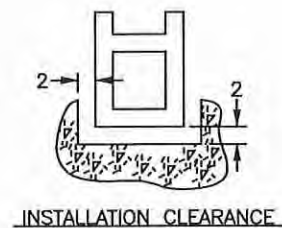
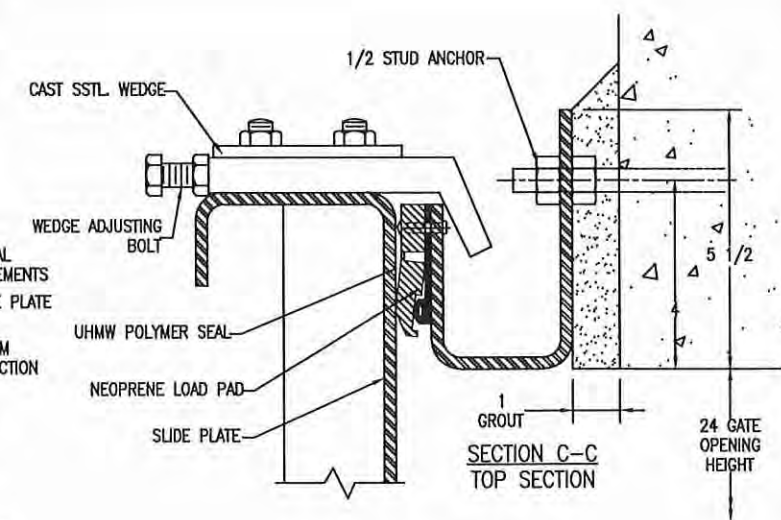
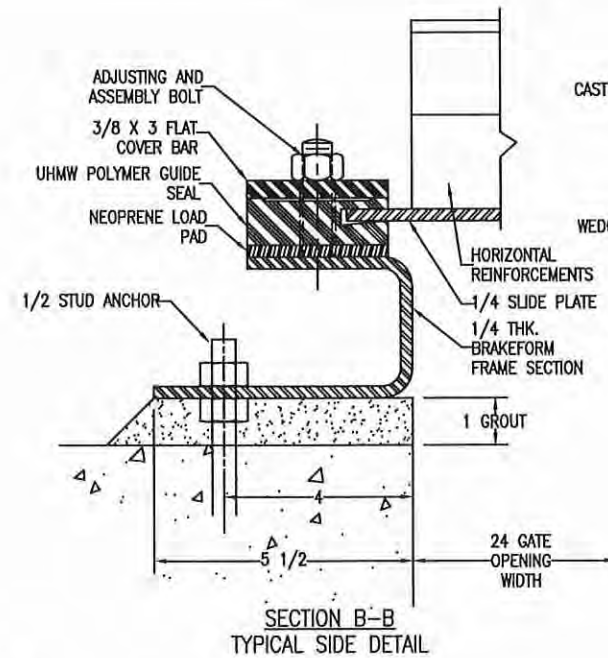
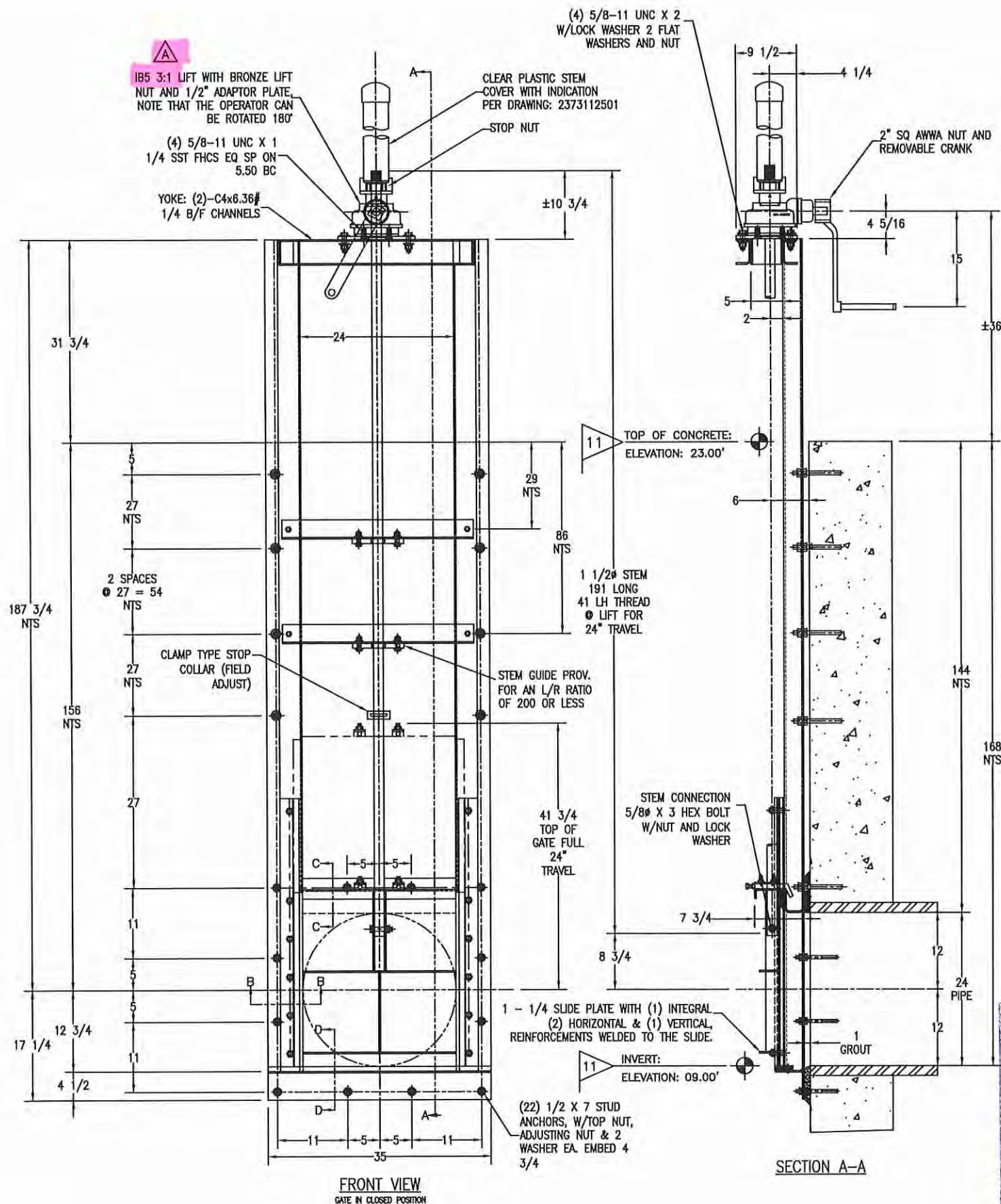

- NOTES:
- CASTING TOLERANCES APPLY ON ALL UNMACHINED SURFACES.
 - SEE MANUAL G2500 FOR INSTALLATION AND ADJUSTMENT INSTRUCTIONS
 - ALL DIMENSIONS IN INCHES UNLESS OTHERWISE NOTED.
 - MATERIAL SPECIFICATIONS AND COATINGS PER DRAWING: 2373112500
 - GATE HEAD DESIGN SEATING: 20.00'
MEASURED FROM GATE @ UNSEATING: 20.00'
OPERATING DESIGN HEAD SEATING: 13.00'
MEASURED FROM GATE @ UNSEATING: 13.00'
 - TAG: HG561 24x24
 - ENGINEER: CITY OF GRAND JUNCTION
 - LOCATION GRAND JUNCTION, CO
 - REFERENCE SPECIFICATION SECTION: IFB-4503-18-DH
 - REFERENCE PLAN DRAWINGS: CONTROL STRUCTURE NO1, 2, & 3
 - PLEASE CONFIRM THE GATE SIZE & TRAVEL, THE TOP OF CONCRETE AND INVERT ELEVATIONS, AS WELL AS THE INVERT CONFIGURATION.

DATE: 6-7-18 BY: Lee Cooper

NO EXCEPTION TAKEN

MAKE CORRECTIONS NOTED

REVISE & RESUBMIT

REJECTED

This stop drawing review is for general conformance with contract documents only and does not relieve the contractor of his responsibility for compliance with requirements of the drawings and specifications.

CITY OF GRAND JUNCTION
COLORADO

HYDRO GATE

24" X 24" MODEL HG561 SLIDE GATE
WALL MOUNTED, SELF-CONTAINED, RISING STEM, TOP SEAL
QUANTITY: 1 MATERIAL: 316 SST SCALE: 1'=1/2"

THIS IS A PROPRIETARY DESIGN OF HYDRO GATE, LLC. THE DESIGN, DATA AND INFORMATION RELATING THERETO IS NOT TO BE USED, DISSEMINATED OR REPRODUCED IN WHOLE OR IN PART WITHOUT THE EXPRESS WRITTEN CONSENT OF HYDRO GATE, LLC.

| REV. | DATE | INITIALS | DRAWN BY | CUSTOMER NO. | SALES |
|------|----------|----------|------------|--------------|-------------|
| A | 06/06/18 | QP | QP | 2018-0000292 | 2373112 |
| | | | CHECKED BY | DATE | DRAWING NO. |
| | | | | 05/22/18 | 2373112-02 |

MATERIAL SPECIFICATIONS

| GATE PART OR ITEM OF ASSEMBLY | MATERIAL DESCRIPTION | MATERIAL CODE | MATERIALS SHOWN IN ASTM SPECIFICATION UNLESS NOTED OTHERWISE |
|--|----------------------|---------------|---|
| <u>EMBEDMENTS</u> | | | |
| STUD ANCHORS | STAINLESS STEEL | (P) | A276, TYPE 316 |
| STUD ANCHOR NUTS | STAINLESS STEEL | (P) | F594, ALLOY GROUP 2 (316) |
| <u>GATE ASSEMBLY</u> | | | |
| FRAME (SIDE ANGLES, FILLER AND COVER BARS) SLIDE PLATES AND REINFORCINGS | STAINLESS STEEL | (P) | A276, TYPE 316 OR 316L (STRUCT.) A240, TYPE 316 OR 316L (PLATES) |
| FASTENERS | STAINLESS STEEL | (P) | F593 (BOLTS), ALLOY GROUP 2 (316) F594 (NUTS), ALLOY GROUP 2 (316) |
| RETAINER | STAINLESS STEEL | (P) | A276, TYPE 316 |
| FLUSH BOTTOM SEAL | EPDM | (BB) | D2000, GRADE 1BE625 |
| UHMW SEATING SURFACE | POLYETHYLENE | (T) | D4020 |
| <u>STEM AND ACCESSORIES</u> | | | |
| STEM | STAINLESS STEEL | (P) | A276, TYPE 316 |
| <u>LIFT ASSEMBLY</u> | | | |
| LIFT HANDWHEEL/CRANK | CAST ALUMINUM | (R) | B26, ALLOY AA713 |
| LIFT HOUSING | CAST IRON | (A) | A126, CLASS B |
| LIFT NUT | MANGANESE BRONZE | (K) | B584, ALLOY 865 |
| STOP NUT | ALUMINUM | (R) | B211, ALLOY 6061-T6 |
| CLAMP TYPE STOP COLLAR | STAINLESS STEEL | (P) | A276, TYPE 316 |
| <u>STEM GUIDE</u> | | | |
| INTEGRAL STEM GUIDE ANGLE | STAINLESS STEEL | (P) | A276, TYPE 316 OR 316L (STRUCT.) |
| STEM GUIDE BLOCK | UHMW | (T) | D4020 |
| FASTENERS | STAINLESS STEEL | (P) | F593 (BOLTS), ALLOY GROUP 2 (316) F594 (NUTS), ALLOY GROUP 2 (316) |

DATE: 6-7-18 BY: Lee Cooper

NO EXCEPTION TAKEN
 MAKE CORRECTIONS NOTED
 REVISE & RESUBMIT
 REJECTED

This shop drawing review is for general conformance with contract documents only and does not relieve the contractor of his responsibility for compliance with requirements of the drawings and specifications.

CITY OF GRAND JUNCTION
COLORADO

COATING SPECIFICATIONS

CLEANING: BLAST CLEAN (PER STEEL STRUCTURES PAINTING COUNCIL)
 _____ NEAR WHITE BLAST _____ GRADE _____ SSPC-SP10 _____

SUBMERSIBLE COATING: _____ AMERON, AMERLOCK 400 HIGH SOLIDS EPOXY _____ COLOR GR-2 MEDIUM GRAY
2 - 3 SHOP COATS FOR A TOTAL DRY FILM THICKNESS OF 12 MILS MIN.
 FOR THE FOLLOWING COMPONENTS:

NONE

NON-SUBMERGED COATING: _____ AMERON, AMERLOCK 400 HIGH SOLIDS EPOXY _____ COLOR GR-2 MEDIUM GRAY
 (PRIME COAT) ONE SHOP COATS FOR A TOTAL DRY FILM THICKNESS OF 5 MILS MIN.
 FOR THE FOLLOWING COMPONENTS:

NON-SUBMERGED COATING: _____ AMERON, AMERCOAT 450H POLYURETHANE _____ COLOR GR-2 MEDIUM GRAY
 (TOP COAT) ONE SHOP COATS FOR A TOTAL DRY FILM THICKNESS OF 3 MILS MIN.
 FOR THE FOLLOWING COMPONENTS:

CAST IRON LIFT HOUSING

NOTES:

| | | | |
|-------------------|------|--|---------------------------|
| HYDRO GATE | | MATERIAL AND COATING SPECIFICATIONS FOR HG561S SLIDE GATES | |
| | | THIS IS A PROPRIETARY DESIGN OF HYDRO GATE CORP. THE DESIGN, DATA AND INFORMATION RELATING THERETO IS NOT TO BE USED, DISSEMINATED OR REPRODUCED IN WHOLE OR IN PART WITHOUT THE EXPRESS WRITTEN CONSENT OF HYDRO GATE CORP. | |
| REV. | DATE | INITIALS | |
| | | | |
| | | | |
| DRAWN BY QP | | CUSTOMER NO. 2018-00000292 | SALES 2373112 |
| CHECKED BY | | DATE 05/22/18 | DRAWING NO. 2373112500 |

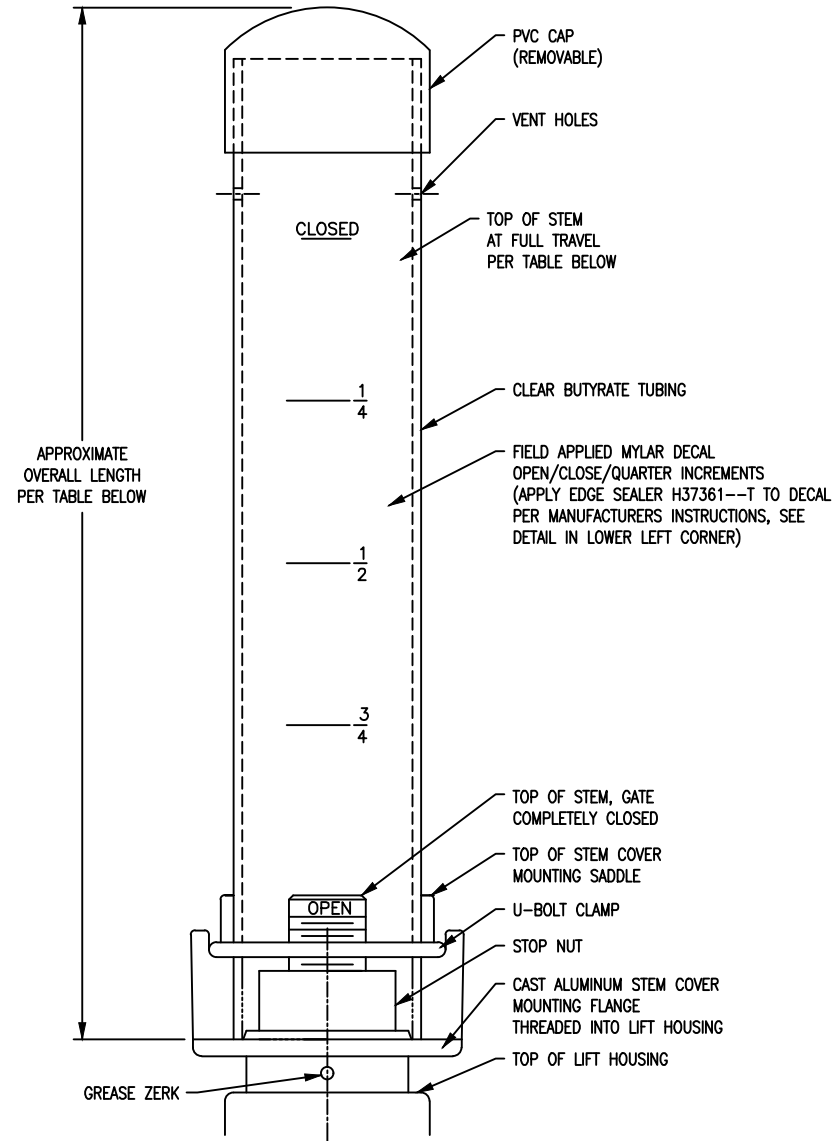
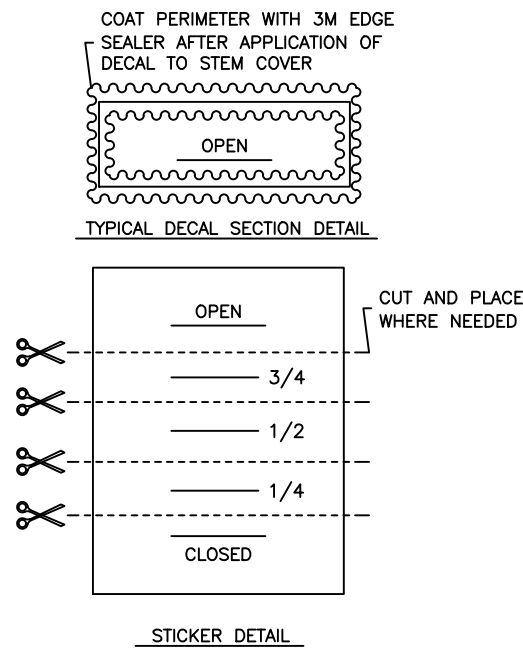

DETAIL A
TYPICAL STEM COVER FOR GATES WITH MANUAL HANDCRANK

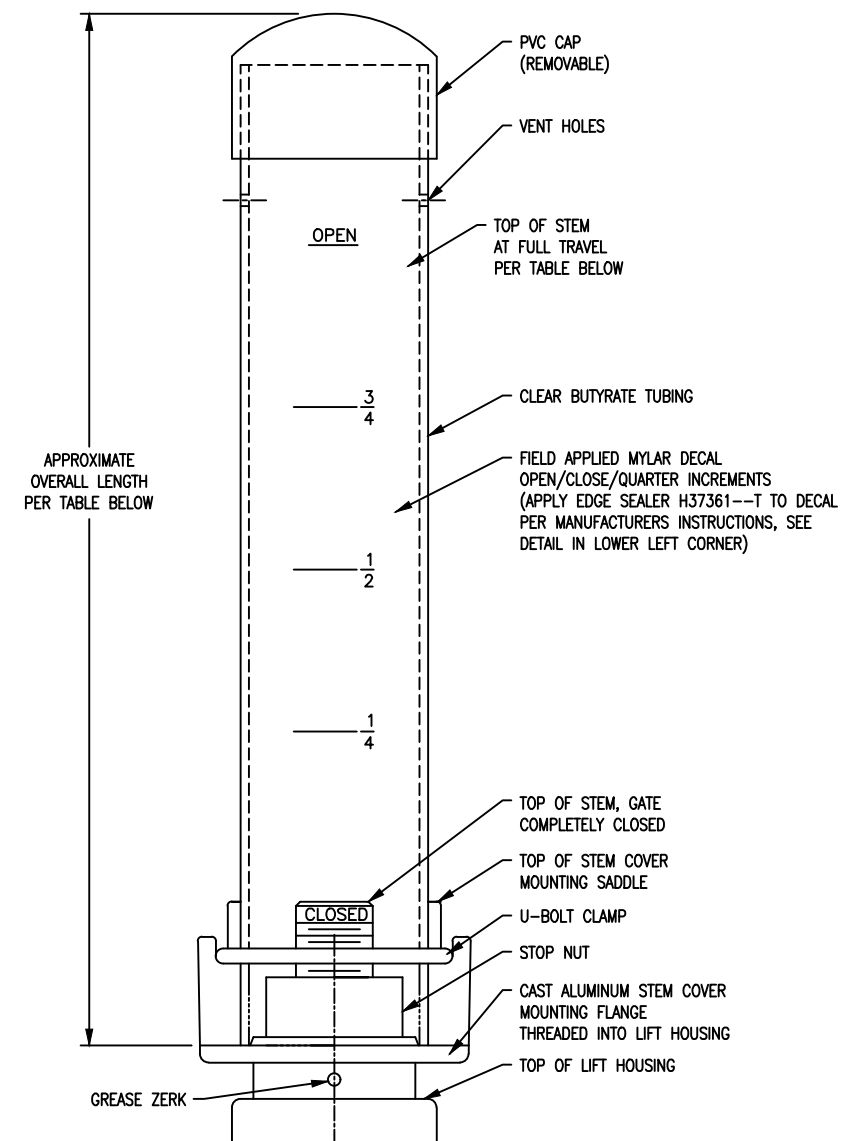

DETAIL B
TYPICAL STEM COVER FOR GATES WITH MANUAL HANDCRANK

| REFERENCE INSTALLATION DRAWING | GATE SIZE | LIFT MODEL | STEM COVER DETAIL | FULL GATE TRAVEL | STEM COVER PART NUMBER | APPROXIMATE OVERALL LENGTH | QUANTITY |
|--------------------------------|-----------|------------|-------------------|------------------|------------------------|----------------------------|----------|
| 2373112-01 | 60" X 36" | IB5 2:1 | DETAIL A | 36' | H34816--T | 46" | 4 |
| 2373112-02 | 24" X 24" | IB5 2:1 | DETAIL B | 24" | H34814--T | 34" | 1 |
| | | | | | | | |
| | | | | | | | |
| | | | | | | | |

HYDRO GATE®

CLEAR BUTYRATE STEM COVERS WITH MYLAR DECAL POSITION INDICATION OPEN/CLOSE/QUARTER INCREMENTS

THIS IS A PROPRIETARY DESIGN OF HYDRO GATE CORP. THE DESIGN, DATA AND INFORMATION RELATING THERETO IS NOT TO BE USED, DISSEMINATED OR REPRODUCED IN WHOLE OR IN PART WITHOUT THE EXPRESS WRITTEN CONSENT OF HYDRO GATE CORP.

| | | | | | | |
|------------|------|----------|--------------|--|-------------|--|
| REV. | DATE | INITIALS | | | | |
| | | | | | | |
| DRAWN BY | | | CUSTOMER NO. | | SALES | |
| QP | | | 2018-0000292 | | 2373112 | |
| CHECKED BY | | | DATE | | DRAWING NO. | |
| | | | 05/22/18 | | 2373112501 | |

HYDRO GATE CORPORATION
MANUAL OPERATOR SELECTION

Hydro Gate Job #: 2373112-01
Gate Tag: HG1 60x36
By: QP
Date: 5/22/2018
Rev: _____

Design Torque (Max Open Torque, T_2) = 39 lb
Selected Stem Diameter = 1.50 in
Thread Factor = 0.0160
Handwheel/Crank Radius = **15 in**
Design Pull on Operator = **40 lb**
Gate Travel = 36 in

Req'd Mechanical Advantage

$MA = T_2 / (R/12) * Pull(lb) = 0.786$

Minimum MA to meet
rimpull requirement.

Selected Lift IB5

Selected Gear Ratio = **3**
Actual Mechanical Advantage = **2.55**
Drive Sleeve Turns to Stroke = **72**
Handwheel Turns to Stroke = **216**

MA = GR*eff
Refer to GB table, or
catalog info, for
efficiencies and ratios.

Actual Pull Required

$Pull(lb) = T_2 / ((R/12) * GR * eff) = 12 lb$

| | |
|---|------------------------|
| DATE: <u>6-7-18</u> | BY: <u>Lee Cooper</u> |
| <input checked="" type="checkbox"/> | NO EXCEPTION TAKEN |
| <input type="checkbox"/> | MAKE CORRECTIONS NOTED |
| <input type="checkbox"/> | REVISE & RESUBMIT |
| <input type="checkbox"/> | REJECTED |
| This shop drawing review is for general conformance with contract documents only and does not relieve the contractor of his responsibility for compliance with requirements of the drawings and specifications. | |
| CITY OF GRAND JUNCTION COLORADO | |

HYDRO GATE CORPORATION
MANUAL OPERATOR SELECTION

Hydro Gate Job #: 2373112-02
Gate Tag: HG561 24x24
By: QP
Date: 5/22/2018
Rev: _____

Design Torque (Max Open Torque, T_2) = 30 lb
Selected Stem Diameter = 1.50 in
Thread Factor = 0.0160
Handwheel/Crank Radius = **15 in**
Design Pull on Operator = **40 lb**
Gate Travel = 24 in

Req'd Mechanical Advantage

$MA = T_2 / ((R/12) * Pull(lb)) = 0.592$

Minimum MA to meet
rimpull requirement.

Selected Lift ~~IB5 2.4~~

Selected Gear Ratio = **3**
Actual Mechanical Advantage = **2.55**
Drive Sleeve Turns to Stroke = **48**
Handwheel Turns to Stroke = **144**

MA = GR*eff
Refer to GB table, or
catalog info, for
efficiencies and ratios.

Actual Pull Required

$Pull(lb) = T_2 / ((R/12) * GR * eff) = 9 lb$

| | |
|---|------------------------|
| DATE: <u>6-7-18</u> BY: <u>Lee Cooper</u> | |
| <input checked="" type="checkbox"/> | NO EXCEPTION TAKEN |
| <input type="checkbox"/> | MAKE CORRECTIONS NOTED |
| <input type="checkbox"/> | REVISE & RESUBMIT |
| <input type="checkbox"/> | REJECTED |
| This shop drawing review is for general conformance with contract documents only and does not relieve the contractor of his responsibility for compliance with requirements of the drawings and specifications. | |
| CITY OF GRAND JUNCTION COLORADO | |