



Purchasing Division

## ADDENDUM NO. 1

**DATE:** December 10, 2019  
**FROM:** City of Grand Junction Purchasing Division  
**TO:** All Offerors  
**RE:** Suplizio Stadium Structural Repairs IFB-4729-20-DH

Offerors responding to the above referenced solicitation are hereby instructed that the requirements have been clarified, modified, superseded and supplemented as to this date as hereinafter described.

Please make note of the following clarifications:

1. Q. Can Contractors have a second opportunity to view the project site?

A. Yes, the project site shall be available for contractors to view a second time on Wednesday, December 11, 2019 from 10:00am – 2:00pm.

2. Q. Can you provide the Thunder Mountain testing results?

A. Yes. See attached.

3. Q. What are the schedules for use of the stadium during construction timeframe?

A. The GJ baseball schedule is still to be determined, however, the CMU schedule is attached.

4. See attached corrected project drawings.

The original solicitation for the project noted above is amended as noted.

All other conditions of subject remain the same.

Respectfully,

A handwritten signature in black ink, appearing to read "Duane Hoff Jr.", written over a white background.

Duane Hoff Jr., Senior Buyer  
City of Grand Junction, Colorado

# THUNDER MOUNTAIN TESTING

2970 N. Ronlin Avenue / Grand Junction, Colorado 81504

Office (970) 256-9965 / Cell (970) 210-7008 / Fax (970) 314-7067

E-Mail: kxkid39@aol.com / www.thundermountaintesting.com

City of Grand Junction – Parks & Recreation  
2529 High Country Court  
Grand Junction, CO 81501

February 19, 2019

ATTN: Mr. Marc Mancuso

RE: Suplizio Field  
North Avenue & 12<sup>th</sup> Street  
Grand Junction, CO  
\*Ultrasonic Thickness Inspection – Bleacher Seats

As requested by you, ultrasonic thickness inspection was conducted on both the North and West bleacher seating for material thickness loss due to visible corrosion areas. I met with you on site to review project requirements and scope of work as detailed in our cost proposal to you dated January 14, 2019 listed as “REVISION 1”.

Ultrasonic thickness inspection began on the North-East corner of the stadium seating and progressed in a western direction along the seating and concluding at the south seating areas. Inspection was conducted utilizing a Dakota Ultrasonics Model CMX Material and Coating Thickness Gauge – S/N 7030. The transducer used was a 5 MHz, ¼” Diameter dual element transducer. Calibration was conducted daily and verified to be within .001”. The baseline average wall thickness for the bleacher seating listed below was observed to be approximately .189”, unless otherwise noted. A total of approximately 25% of the visually evident corroded areas including the seating, stair threads and riser threads were inspected for remaining material thickness. Prior to testing, all inspection sites were power wire brushed from the back side to remove all foreign material to include rusted material and paint. Between 2 – 3 tests per site were taken to get an overall average of remaining material thickness. Material thickness was marked directly adjacent to each inspection site with blue permanent markings. Both single point and/or multiple point readings are listed below. Thickness readings documented are in 1/1000 of an inch increment. The following thickness readings were observed at the following Sections and Row Numbers. All number marked in red indicate equal or greater than 25% Original Material Loss:

<u>SECTION</u>	<u>ROW</u>	<u>LOCATION</u>	<u>TEST THICKNESS(S)</u>
U – V	K	Above Support Beam	.142
U – V	M	Bleacher Mid-Span: East	.158
U – V	M	Bleacher Mid-Span: West	.153
U – V	B	Bleacher Mid-Span: East	.142

<u>SECTION</u>	<u>ROW</u>	<u>LOCATION</u>	<u>TEST THICKNESS(S)</u>
U - V	B	Bleacher Mid-Span: West	.165
U - V	B	Above Support Beam	.142
S - T	K	Above Support Beam	.174
S - T	O	Above Support Beam	.165
S - T	B	Bleacher Mid-Span: East	.111
S - T	B	Bleacher Mid-Span: West	.126
S - T	C	Bleacher Mid-Span: East	.126
S - T	F	Bleacher Mid-Span: East	.126 - .153
S - T	C	Bleacher Mid-Span: West	.059 - .096
S - T	D	Bleacher Mid-Span: East	.126
S - T	D	Bleacher Mid-Span: West	.126 - .158
S - T	G	Bleacher Mid-Span: West	.096 - .136
S - T	Stair Handrail	West Corner: 4 <sup>th</sup> Picket Up	Broken
S - T	Between A - B	Stair Landing @ S: Vertical Plt.	Thru Holes
R - S	H	Stair Landing @ Vertical Plt.	Thru Holes
R - S	C	Bleacher Mid-Span: East	.117 - .127
R - S	D	Bleacher Mid-Span: East	.117 - .127
R - S	S	Bleacher Mid-Span: East	.155
R - S	F	Bleacher Mid-Span: East	.127 - .157
R - S	A	Stair Landing @ A: Vertical Plt.	Thru Holes
Q - R	A, C, D, G, N	Thru Holes in Horizontal and/or Vert. Plate	
Q - R	A	Bleacher Mid-Span: East	.079 - .114
Q - R	C	Bleacher Mid-Span: East	.077 - .154
Q - R	D	Bleacher Mid-Span: East	.077 - .154
Q - R	F	Bleacher Mid-Span: East	.077 - .122
P - Q	S	Bleacher Mid-Span: West	.127 - .154
P - Q	D	Bleacher Mid-Span: East	.096 - .122
P - Q	F	Bleacher Mid-Span: East	.109 - .158
P - Q	Below Handrail	Stair Down @ Vertical Plt.	Thru Holes
P - Q	Below Handrail	Concrete Level @ Vertical Plt.	Thru Holes
P - Q	Landing to A	2 Step Stair @ Vertical Plt.	Thru Holes
P - Q	G, H	Stair Landing @ Vertical Plt.	Thru Holes
P - Q	A	Bleacher Mid-Span: West	.082 - .142
P - Q	B	Bleacher Mid-Span: West	.127
P - Q	D	Bleacher Mid-Span: West	.142

Respectfully Submitted,

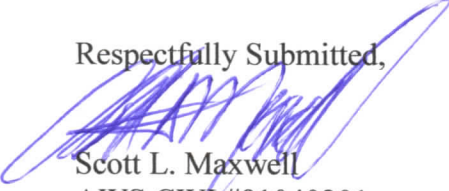
  
 Scott L. Maxwell  
 AWS CWI #91040201  
 ASNT NDT Level III #30242  
 Thunder Mountain Testing



# THUNDER MOUNTAIN TESTING

2970 N. Ronlin Avenue / Grand Junction, Colorado 81504

Office (970) 256-9965 / Cell (970) 210-7008 / Fax (970) 314-7067

E-Mail: [kxkid39@aol.com](mailto:kxkid39@aol.com) / [www.thundermountaintesting.com](http://www.thundermountaintesting.com)

City of Grand Junction – Parks & Recreation  
2529 High Country Court  
Grand Junction, CO 81501

February 20, 2019

ATTN: Mr. Marc Mancuso

RE: Suplizio Field  
North Avenue & 12<sup>th</sup> Street  
Grand Junction, CO  
\*Ultrasonic Thickness Inspection – Bleacher Seats

As requested by you, ultrasonic thickness inspection was conducted on both the North and West bleacher seating for material thickness loss due to visible corrosion areas. I met with you on site to review project requirements and scope of work as detailed in our cost proposal to you dated January 14, 2019 listed as “REVISION 1”.

Ultrasonic thickness inspection began on the North-East corner of the stadium seating and progressed in a western direction along the seating and concluding at the south seating areas. Inspection was conducted utilizing a Dakota Ultrasonics Model CMX Material and Coating Thickness Gauge – S/N 7030. The transducer used was a 5 MHz, ¼” Diameter dual element transducer. Calibration was conducted daily and verified to be within .001”. The baseline average wall thickness for the bleacher seating listed below was observed to be approximately .189”, unless otherwise noted. A total of approximately 25% of the visually evident corroded areas including the seating, stair threads and riser threads were inspected for remaining material thickness. Prior to testing, all inspection sites were power wire brushed from the back side to remove all foreign material to include rusted material and paint. Between 2 – 3 tests per site were taken to get an overall average of remaining material thickness. Material thickness was marked directly adjacent to each inspection site with blue permanent markings. Both single point and/or multiple point readings are listed below. Thickness readings documented are in 1/1000 of an inch increment. The following thickness readings were observed at the following Sections and Row Numbers. All number marked in red indicate equal or greater than 25% Original Material Loss:

<u>SECTION</u>	<u>ROW</u>	<u>LOCATION</u>	<u>TEST THICKNESS(S)</u>
O – P	B	Bleacher Mid-Span: East	.112
O – P	D	Bleacher Mid-Span: East	.127
O – P	F	Bleacher Mid-Span: East	.142
O – P	B	Bleacher Mid-Span: West	.111 - .126

<u>SECTION</u>	<u>ROW</u>	<u>LOCATION</u>	<u>TEST THICKNESS(S)</u>
O - P	C	Bleacher Mid-Span: West	.064 - .097
O - P	C	Bleacher Mid-Span: East	.077 - .126
O - P	E	Bleacher Mid-Span: West	.142
O - P	G	Bleacher Mid-Span: East	.064 - .095
O - P	G, J, L	Stair Landing: Holes in Horiz. & Vert. Plt.	
N - O	S	Bleacher Mid-Span: East	.127 - .154
N - O	B	Bleacher Mid-Span: East	.112 - .127
N - O	E	Bleacher Mid-Span: East	.127
N - O	G, H	Stair Landing: Holes in Vertical Plt.	
N - O	C	Bleacher Mid-Span: East	.095
N - O	D	Bleacher Mid-Span: East	.095
M - N	N	Bleacher Mid-Span: West	.127
L - M	C	Bleacher Mid-Span: East	.059 - .079
L - M	C	Bleacher Mid-Span: West	.079
L - M	E	Bleacher Mid-Span: West	.111
K - L	E	Bleacher Mid-Span: East	.059
K - L	B	Above Support Beam	.155
K - L	O	Bleacher Mid-Span: Center	.067 - .096
K - L	H	Stair Landing @ L: Vertical Plt. Thru Hole	
J - K	R	Bleacher Mid-Span: Center	.104 - .111
J - K	D	Bleacher Mid-Span: East	.111
J - K	N, W	Thru Holes in Vertical Plt.	
J - K	A	Thru Holes in Vertical Plt.	

**Baseline Average Wall Thickness Change to .215**

D	K	Bleacher Mid-Span: North	.015
D	B	Bleacher Mid-Span: North	.120 - .145
B - C	A	Bleacher Mid-Span: North	.095 - .115
B - C	C	Bleacher Mid-Span: North	.110 - .137
B - C	B	Stair Landing @ Vertical Plt.	
A - B	B	Bleacher Mid-Span: North	.137
A - B	A	Bleacher Mid-Span: South	.115

Respectfully Submitted,

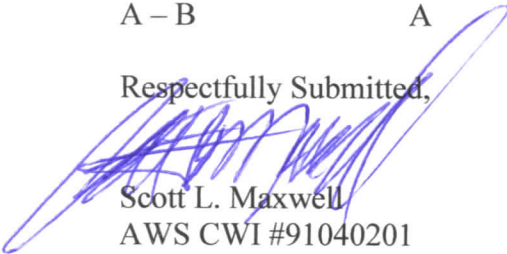
  
 Scott L. Maxwell  
 AWS CWI #91040201  
 ASNT NDT Level III #30242  
 Thunder Mountain Testing

 Scott L. Maxwell  
 CWI 91040201  
 QC1 EXP. 4/1/2021

# THUNDER MOUNTAIN TESTING

2970 N. Ronlin Avenue / Grand Junction, Colorado 81504  
Office (970) 256-9965 / Cell (970) 210-7008 / Fax (970) 314-7067  
E-Mail: kxkid39@aol.com / www.thundermountaintesting.com

City of Grand Junction – Parks & Recreation  
2529 High Country Court  
Grand Junction, CO 81501

March 20, 2019

ATTN: Mr. Marc Mancuso

RE: Stocker Stadium  
North Avenue & 12<sup>th</sup> Street  
Grand Junction, CO  
\*Ultrasonic Thickness Inspection – Bleacher Seats

As requested by you, ultrasonic thickness inspection was conducted the West bleacher seating for material thickness loss due to visible corrosion areas. I met with you on site to review project requirements and scope of work as detailed in our cost proposal to you dated January 14, 2019 listed as “REVISION 1”.

Ultrasonic thickness inspection began on the North corner of the stadium seating and progressed in a southern direction along the seating. Inspection was conducted utilizing a Dakota Ultrasonics Model CMX Material and Coating Thickness Gauge – S/N 7030. The transducer used was a 5 MHz, ¼” Diameter dual element transducer. Calibration was conducted daily and verified to be within .001”. The baseline average wall thickness for the bleacher seating listed below was observed to be approximately .182”, unless otherwise noted. A total of approximately 25% of the visually evident corroded areas including the seating, stair threads and riser threads were inspected for remaining material thickness. Prior to testing, all inspection sites were power wire brushed from the back side to remove all foreign material to include rusted material and paint. Since the section number was all the same (Section S), below I listed the areas as “Bays”, starting from the North and progressing South, including the Stairs. Bays are distinguished by the back-side East-West support seating main framing beams. Between 2 – 3 tests per site were taken to get an overall average of remaining material thickness. Material thickness was marked directly adjacent to each inspection site with blue permanent markings. Both single point and/or multiple point readings are listed below. Thickness readings documented are in 1/1000 of an inch increment. The following thickness readings were observed at the following Sections and Row Numbers. All number marked in red indicate equal or greater than 25% Original Material Loss:

<u>BAY</u>	<u>ROW</u>	<u>LOCATION</u>	<u>TEST THICKNESS(S)</u>
1	B	North End	.136
1	I	North End	.120 - .136

<u>BAY</u>	<u>ROW</u>	<u>LOCATION</u>	<u>TEST THICKNESS(S)</u>
1	J	North End	.088 - .120
2	J	Mid-Span	.105 - .132
3	K	Mid-Span	.120 - .135
<b><u>Baseline Average Wall Thickness Change to .195"</u></b>			
3	E	South End	.152
5	C	Mid-Span	.132
6	E	South End	.010 - .118
6	F	South End	.085 - .118
7	D	South End	.100
10	K	North End	.039 - .150
10	K	Mid-Span	.102 - .147
11	K	North End	.150
11	K	Mid-Span	.145
11	K	South End	.102
12	K	South End	.105 - .160
13	F	Mid-Span	.125 - .148
15	E	North End	.102
17	C	North End	.133
17	L	North End	.161
17	L	Mid-Span	.102 - .133
17	L	South End	Thru Holes
19	M	North End	.148
19	M	Mid-Span	.137 - .140
19	M	South End	.148
19	J	North End	.103 - .137
20	M	North End	.070
20	M	Mid-Span	.085
20	J	North End	.137
20	J	Mid-Span	.137
20	J	South End	.152
*Stair 1 from North	S	Horizontal & Vertical Thread	- Holes in Both
*Stair 1 from North	V	Horizontal & Vertical Thread	- Holes in Both
*Stair 3 from North	J	North Side Floor Plate	.038
*Stair 3 from North	L	North Side Floor Plate	.095 - .104
*Stair 3 from North	K	South Side Floor Plate	.075
*Stair 3 from North	J	South Side Floor Plate	.102
*Stair 4 from North	K	South Side Floor Plate	.148

Respectfully Submitted,

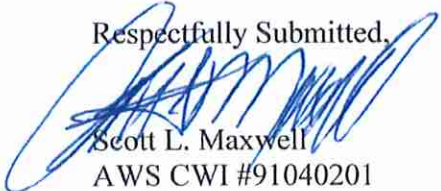

Scott L. Maxwell  
AWS CWI #91040201  
ASNT NDT Level III #30242  
Thunder Mountain Testing



Scott L Maxwell  
CWI 91040201  
QC1 EXP. 4/1/2021



# Colorado Mesa University Athletics

## 2020 Baseball Schedule

Feb 7 (Fri) 4pm	at	Fort Lauderdale, FL NSU Baseball Complex
	<a href="#"><u>Nova Southeastern University</u></a>	
Feb 8 (Sat) 11am	at	Fort Lauderdale, FL NSU Baseball Complex
	<a href="#"><u>Nova Southeastern University</u></a>	
Feb 9 (Sun) 10am	at	Fort Lauderdale, FL NSU Baseball Complex
	<a href="#"><u>Nova Southeastern University</u></a>	
Feb 14 (Fri) 2:30pm	vs	Grand Junction, CO Suplizio Field
	<a href="#"><u>Southern New Hampshire University</u></a>	
Feb 15 (Sat) 1pm	vs	Grand Junction, CO Suplizio Field
	<a href="#"><u>Southern New Hampshire University</u></a>	
Feb 16 (Sun) Noon	vs	Grand Junction, CO Suplizio Field
	<a href="#"><u>Southern New Hampshire University</u></a>	
Feb 20 (Thu) 2:30pm	vs	Grand Junction, CO Suplizio Field
	<a href="#"><u>Northwest Nazarene University</u></a>	
Feb 21 (Fri) Noon	vs	Grand Junction, CO Suplizio Field
	<a href="#"><u>Northwest Nazarene University</u></a> (DH)	
Feb 21 (Fri) 3:30pm	vs	Grand Junction, CO Suplizio Field
	<a href="#"><u>Northwest Nazarene University</u></a> (DH)	
Feb 22 (Sat) 1pm	vs	Grand Junction, CO Suplizio Field
	<a href="#"><u>Northwest Nazarene University</u></a>	
Feb 28 (Fri) 2:30pm	vs	Grand Junction, CO Suplizio Field
	<a href="#"><u>Minot State University</u></a>	
Feb 29 (Sat) Noon	vs	Grand Junction, CO Suplizio Field
	<a href="#"><u>Minot State University</u></a> (DH)	
Feb 29 (Sat) 3:30pm	vs	Grand Junction, CO Suplizio Field
	<a href="#"><u>Minot State University</u></a> (DH)	
Mar 1 (Sun) Noon	vs	Grand Junction, CO Suplizio Field
	<a href="#"><u>Minot State University</u></a>	
Mar 6 (Fri) 3pm	vs	Grand Junction, CO Suplizio Field
	<a href="#"><u>Regis University</u></a>	
Mar 7 (Sat) 1pm	vs	Grand Junction, CO Suplizio Field
	<a href="#"><u>Regis University</u></a> (DH)	
Mar 7 (Sat) 3:30pm	vs	Grand Junction, CO Suplizio Field
	<a href="#"><u>Regis University</u></a> (DH)	
Mar 8 (Sun) Noon	vs	Grand Junction, CO Suplizio Field
	<a href="#"><u>Regis University</u></a>	
Mar 13 (Fri) 3pm	at	Golden, CO Darden Baseball Field
	<a href="#"><u>Colorado School of Mines</u></a>	
Mar 14 (Sat) 1pm	at	Golden, CO Darden Baseball Field
	<a href="#"><u>Colorado School of Mines</u></a> (DH)	
Mar 14 (Sat) 3:30pm	at	Golden, CO Darden Baseball Field
	<a href="#"><u>Colorado School of Mines</u></a> (DH)	
Mar 15 (Sun) Noon	at	Golden, CO Darden Baseball Field
	<a href="#"><u>Colorado School of Mines</u></a>	
Mar 20 (Fri) 6:05pm	vs	Grand Junction, CO Suplizio Field
	<a href="#"><u>UCCS</u></a>	
Mar 21 (Sat) 1pm	vs	Grand Junction, CO Suplizio Field
	<a href="#"><u>UCCS</u></a> (DH)	
Mar 21 (Sat) 3:30pm	vs	Grand Junction, CO Suplizio Field
	<a href="#"><u>UCCS</u></a> (DH)	
Mar 22 (Sun) Noon	vs	Grand Junction, CO Suplizio Field

	<a href="#"><u>UCCS</u></a>	
Mar 27 (Fri) 3pm	at	Lakewood, CO All Star Park
	<a href="#"><u>Colorado Christian University</u></a>	
Mar 28 (Sat) Noon	at	Lakewood, CO All Star Park
	<a href="#"><u>Colorado Christian University</u></a> (DH)	
Mar 28 (Sat) 2:30pm	at	Lakewood, CO All Star Park
	<a href="#"><u>Colorado Christian University</u></a> (DH)	
Mar 29 (Sun) Noon	at	Lakewood, CO All Star Park
	<a href="#"><u>Colorado Christian University</u></a>	
Apr 3 (Fri) 6:05pm	vs	Grand Junction, CO Suplizio Field
	<a href="#"><u>CSU - Pueblo</u></a>	
Apr 4 (Sat) 1pm	vs	Grand Junction, CO Suplizio Field
	<a href="#"><u>CSU - Pueblo</u></a> (DH)	
Apr 4 (Sat) 3:30pm	vs	Grand Junction, CO Suplizio Field
	<a href="#"><u>CSU - Pueblo</u></a> (DH)	
Apr 5 (Sun) Noon	vs	Grand Junction, CO Suplizio Field
	<a href="#"><u>CSU - Pueblo</u></a>	
Apr 9 (Thu) 3pm	at	Alamosa, CO ASU Baseball Field
	<a href="#"><u>Adams State University</u></a>	
Apr 10 (Fri) 1pm	at	Alamosa, CO ASU Baseball Field
	<a href="#"><u>Adams State University</u></a> (DH)	
Apr 10 (Fri) 3:30pm	at	Alamosa, CO ASU Baseball Field
	<a href="#"><u>Adams State University</u></a> (DH)	
Apr 11 (Sat) Noon	at	Alamosa, CO ASU Baseball Field
	<a href="#"><u>Adams State University</u></a>	
Apr 17 (Fri) 3pm	at	Las Vegas, NM Brandt Field
	<a href="#"><u>New Mexico Highlands University</u></a>	
Apr 18 (Sat) 1pm	at	Las Vegas, NM Brandt Field
	<a href="#"><u>New Mexico Highlands University</u></a> (DH)	
Apr 18 (Sat) 3:30pm	at	Las Vegas, NM Brandt Field
	<a href="#"><u>New Mexico Highlands University</u></a> (DH)	
Apr 19 (Sun) Noon	at	Las Vegas, NM Brandt Field
	<a href="#"><u>New Mexico Highlands University</u></a>	
Apr 24 (Fri) 6:05pm	vs	Grand Junction, CO Suplizio Field
	<a href="#"><u>MSU Denver</u></a>	
Apr 25 (Sat) 1pm	vs	Grand Junction, CO Suplizio Field
	<a href="#"><u>MSU Denver</u></a> (DH)	
Apr 25 (Sat) 3:30pm	vs	Grand Junction, CO Suplizio Field
	<a href="#"><u>MSU Denver</u></a> (DH)	
Apr 26 (Sun) Noon	vs	Grand Junction, CO Suplizio Field
	<a href="#"><u>MSU Denver</u></a>	
Apr 30 (Thu) 6pm	at	St. George, UT Bruce Hurst Field
	<a href="#"><u>Dixie State University</u></a>	
May 1 (Fri) 3:30pm	at	St. George, UT Bruce Hurst Field
	<a href="#"><u>Dixie State University</u></a> (DH)	
May 1 (Fri) 6pm	at	St. George, UT Bruce Hurst Field
	<a href="#"><u>Dixie State University</u></a> (DH)	
May 2 (Sat) Noon	at	St. George, UT Bruce Hurst Field
	<a href="#"><u>Dixie State University</u></a>	
<b>RMAC Baseball Tournament</b>		
· May 6 (Wed)	vs	TBD
	<a href="#"><u>RMAC Tournament</u></a>	
<b>NCAA Regionals</b>		
· May 14 (Thu)	vs	
	<a href="#"><u>NCAA Regional Tournament</u></a>	
<b>NCAA Super Regionals</b>		

· May 22 (Fri)

vs

[NCAA Super Regionals](#)

NCAA Championships

· May 30 (Sat)

[NCAA Championships](#)

Cary, N.C. USA Baseball Training Complex

All game times are listed in Mountain  
Dates and times are subject to change without notice

Copyright © 2019 Colorado Mesa University Athletics

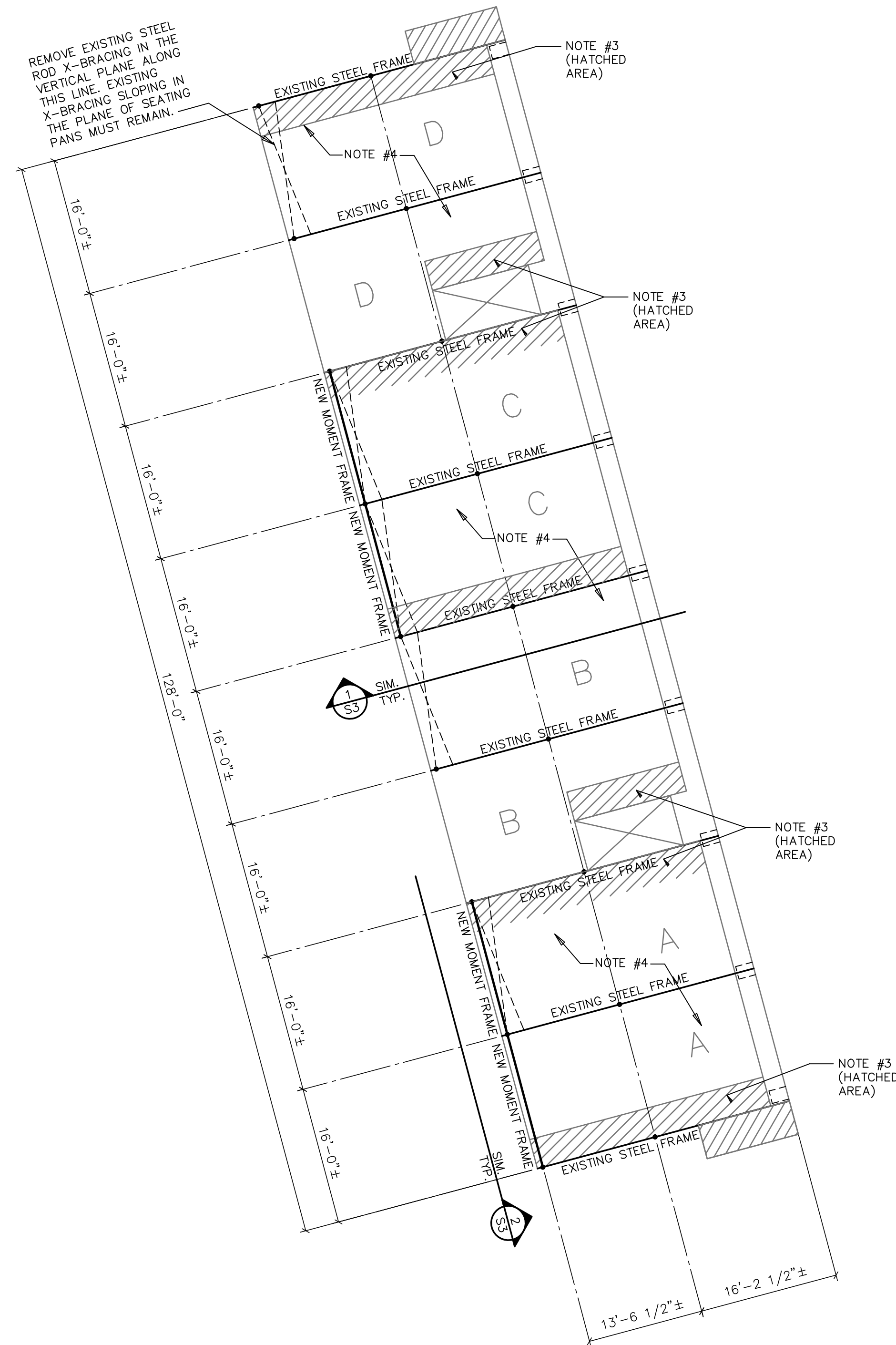

**EXISTING SOUTH (RIGHT FIELD) SEATING PLAN** 3/32"=1'-0" NORTH

- DIMENSIONS AND ORIENTATION OF SEATING STRUCTURE ARE APPROXIMATE. VERIFY DIMENSIONS AND CONDITIONS IN FIELD PRIOR TO FABRICATION AND CONSTRUCTION.
- EXISTING SEATING PANS CONSIST OF BENT 3/16" PLATE STEEL, PAINTED, SPANNING BETWEEN SLOPED STEEL FRAMES. STAIRS CONSIST OF STEEL DIAMOND PLATE TREADS, RISERS, AND SIDE CLOSURES INSTALLED ON TOP OF THE SEATING PANS.
- REPLACE STAIR TREAD AND RISER PLATES WITH NEW MATERIAL, WHERE CORROSION OF THE EXISTING STEEL RISERS AND TREADS HAS REDUCED THE PLATE THICKNESS TO LESS THAN 1/8" (ALTERNATIVE #1).
- REPLACE SEATING PANS EXHIBITING CORROSION WHERE THE PLATE THICKNESS HAS BEEN REDUCED TO LESS THAN 1/8" THICKNESS. LOCATIONS OF REDUCED THICKNESS HAVE BEEN SURVEYED BY THUNDER MOUNTAIN TESTING, AND ARE LISTED IN REPORTS DATED FEBRUARY 19 AND FEBRUARY 20, 2019. THESE REPORTS SHOULD BE USED TO IDENTIFY SEATING PANS THAT NEED TO BE REPLACED (ALTERNATIVE #2 - SECTIONS P-S).
- NEW STEEL MATERIAL SHALL BE PRIMED WITH A ZINC RICH OR OTHERWISE RUST INHIBITIVE PRIMER SUCH AS TNEC SERIES V10, AND PAINTED WITH A CORROSION PROTECTING COATING SUCH AS TNEC SERIES 30.

GENERAL NOTES	
1. CODES USED FOR DESIGN:	2018 INTERNATIONAL BUILDING CODE, ASCE/SEI 7-16
2. LIVE LOADS USED IN DESIGN:	A. STADIUM SEATING AND STAIRS-----100 PSF
B. WIND:	EXPOSURE-----C RISK CATEGORY-----III V <sub>10</sub> -----115 MPH V <sub>50</sub> -----89 MPH INTERNAL PRESSURE COEFFICIENT C <sub>pi</sub> (OPEN BUILDING)-----0
C. SEISMIC:	SEISMIC DESIGN HAS BEEN PERFORMED IN ACCORDANCE WITH N.E.H.R.P. PROVISIONS AND THE REQUIREMENTS OF ASCE/SEI 7-16 RISK CATEGORY-----III IMPORTANCE FACTOR I <sub>e</sub> -----1.25 R COEFFICIENT-----3.0 SPECTRAL RESPONSE COEFFICIENTS: S <sub>1</sub> -----0.239 S <sub>2</sub> -----0.066 S <sub>0.1</sub> -----0.255 S <sub>0.01</sub> -----0.106
SEISMIC RESPONSE COEFFICIENTS	C <sub>s</sub> -----0.106
SITE CLASS	D
SEISMIC DESIGN CATEGORY	B
BASIC SEISMIC FORCE RESISTING SYSTEM	ORDINARY STEEL MOMENT FRAMES
DESIGN BASE SHEAR	V-----25K
ANALYSIS PROCEDURE	EQUIVALENT LATERAL FORCE PROCEDURE
3. CONCRETE (IF APPLICABLE):	A. ALL CONCRETE SHALL DEVELOP 4,000 P.S.I. COMPRESSIVE STRENGTH IN 28 DAYS. USE TYPE 1/11 CEMENT WITH MAXIMUM WATER/CEMENT RATIO = 0.45, AND 3/4" MAX. COARSE AGGREGATE. B. ALL REINFORCING SHALL CONFORM TO ASTM A615, GRADE 60, EXCEPT COLUMN TIES AND DOWELS TO SLABS ON GRADE MAY BE GRADE 40. C. NO SPLICES OF REINFORCEMENT SHALL BE MADE EXCEPT AS DETAILED OR AUTHORIZED BY THE STRUCTURAL ENGINEER. LAP SPLICES, WHERE PERMITTED, SHALL BE A MINIMUM OF 36 BAR DIAMETERS. MAKE ALL BARS CONTINUOUS AROUND CORNERS. D. STAGGER SPLICES A MINIMUM OF 4'-0" FOR TOP AND BOTTOM CONTINUOUS BARS IN FOUNDATION, UNLESS OTHERWISE SHOWN OR NOTED. E. DETAIL BARS IN ACCORDANCE WITH A.C.I. DETAILING MANUAL AND A.C.I. BUILDING CODE REQUIREMENTS FOR REINFORCED CONCRETE, LATEST EDITIONS. F. PROVIDE ALL ACCESSORIES NECESSARY TO SUPPORT REINFORCING AT POSITIONS SHOWN ON THE DRAWINGS. DO NOT ATTEMPT TO LOCATE REINFORCING DURING CONCRETE PLACEMENT. G. REINFORCEMENT PROTECTION SHALL BE AS FOLLOWS: (1) CONCRETE POURED AGAINST EARTH-----3" (2) FORMED CONCRETE EXPOSED TO EARTH OR WEATHER-----2" (3) FORMED STAIRS OR WALLS NOT EXPOSED TO WEATHER-----3/4" H. PLACE 2-#5 (ONE EACH FACE) WITH 2'-0" PROJECTION AROUND ALL OPENINGS IN CONCRETE UNLESS OTHERWISE SHOWN OR NOTED. I. SLABS, BEAMS, AND GRADE BEAMS SHALL NOT HAVE JOINTS IN A HORIZONTAL PLANE. ANY STOP IN CONCRETE WORK MUST BE MADE AT MIDDLE OF SPAN WITH KEYS AS INDICATED IN THE TYPICAL CONCRETE WALL CONSTRUCTION JOINT DETAIL. ALL CONSTRUCTION JOINTS SHALL BE AS DETAILED OR AS APPROVED BY THE STRUCTURAL ENGINEER. J. WIRE FABRIC REINFORCEMENT MUST LAP ON FULL MESH +2" AT SIDE AND END LAPS, AND SHALL BE TIED TOGETHER.
3. STEEL:	A. ALL STRUCTURAL STEEL WIDE FLANGE SHAPES SHALL CONFORM TO ASTM A992 (F <sub>y</sub> = 50 ksi). ALL RECTANGULAR AND SQUARE HSS SHAPES SHALL CONFORM TO ASTM A500 GRADE B (F <sub>y</sub> = 46 ksi). ALL PIPE SECTIONS SHALL CONFORM TO ASTM A53, GRADE B. ALL STEEL PLATES, CHANNELS, AND ANGLES SHALL CONFORM TO ASTM A36, LATEST EDITIONS. B. STRUCTURAL STEEL SHALL BE DETAILED AND FABRICATED IN ACCORDANCE WITH LATEST PROVISIONS OF THE A.I.S.C. MANUAL OF STEEL CONSTRUCTION. C. USE FRAMED BEAM CONNECTIONS WITH 3/4" DIAMETER ASTM A325 BOLTS, OR WELDED EQUIVALENT, UNLESS OTHERWISE SHOWN OR NOTED. FOR BEAMS WITHOUT DESIGNATED LOADS ON DRAWINGS, SELECT CONNECTIONS TO SUPPORT 50% OF TOTAL UNIFORM LOAD CAPACITY IN BENDING FOR EACH GIVEN BEAM AND SPAN, PLUS THE REACTION DUE TO ANY CONCENTRATED LOADS, MINIMUM OF (2) BOLTS PER CONNECTION. D. ALL WELDERS SHALL HAVE EVIDENCE OF PASSING THE A.W.S. STANDARD QUALIFICATION TESTS.



**SUPLIZIO STADIUM  
BASEBALL SEATING REMEDIATION**

**GRAND JUNCTION, COLORADO  
FOR: CITY OF GRAND JUNCTION PARKS DEPARTMENT**

REVISIONS:

JOB #	19.033
DRAWN BY:	KDN
CHECKED BY:	JAD
DATE:	11/21/19

SHEET #

**S1**

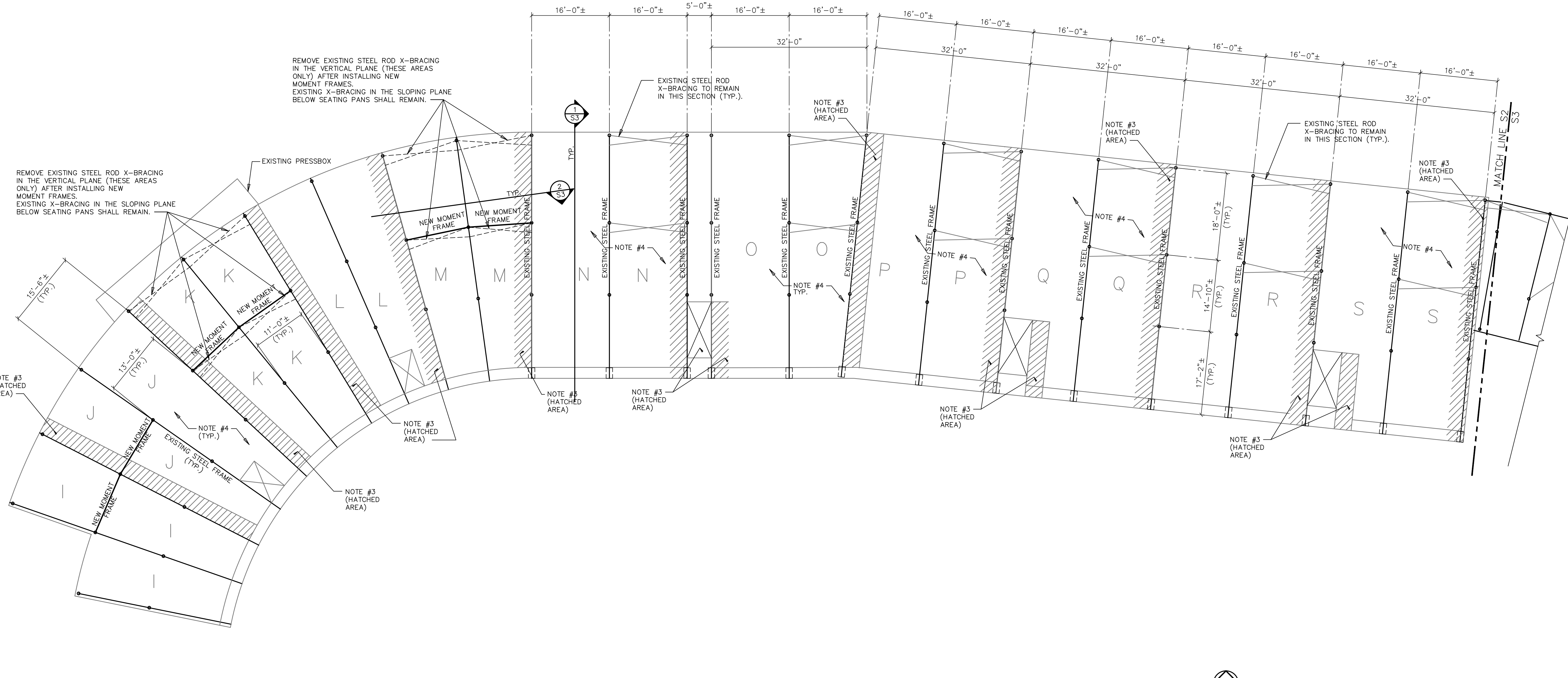

REMOVE EXISTING STEEL ROD X-BRACING IN THE VERTICAL PLANE (THESE AREAS ONLY) AFTER INSTALLING NEW MOMENT FRAMES. EXISTING X-BRACING IN THE SLOPING PLANE BELOW SEATING PANS SHALL REMAIN.

REMOVE EXISTING STEEL ROD X-BRACING IN THE VERTICAL PLANE (THESE AREAS ONLY) AFTER INSTALLING NEW MOMENT FRAMES. EXISTING X-BRACING IN THE SLOPING PLANE BELOW SEATING PANS SHALL REMAIN.

### EXISTING NORTH SEATING PLAN

3/32"=1'-0" NORTH

1. DIMENSIONS AND ORIENTATION OF SEATING STRUCTURE ARE APPROXIMATE. VERIFY DIMENSIONS AND CONDITIONS IN FIELD PRIOR TO FABRICATION AND CONSTRUCTION.
2. EXISTING SEATING PANS CONSIST OF BENT 3/16" PLATE STEEL, PAINTED, SPANNING BETWEEN SLOPED STEEL FRAMES. STAIRS CONSIST OF STEEL DIAMOND PLATE TREADS, RISERS, AND SIDE CLOSURES INSTALLED ON TOP OF THE SEATING PANS.
3. REPLACE STAIR TREAD AND RISER PLATES WITH NEW MATERIAL, WHERE CORROSION OF THE EXISTING STEEL RISERS AND TREADS HAS REDUCED THE PLATE THICKNESS TO LESS THAN 1/8" (ALTERNATIVE #1).
4. REPLACE SEATING PANS EXHIBITING CORROSION WHERE THE PLATE THICKNESS HAS BEEN REDUCED TO LESS THAN 1/8" THICKNESS. LOCATIONS OF REDUCED THICKNESS HAVE BEEN SURVEYED BY THUNDER MOUNTAIN TESTING, AND ARE LISTED IN REPORTS DATED FEBRUARY 19 AND FEBRUARY 20, 2019. THESE REPORTS SHOULD BE USED TO IDENTIFY SEATING PANS THAT NEED TO BE REPLACED (ALTERNATIVE #2 - SECTIONS P-S).
5. NEW STEEL MATERIAL SHALL BE PRIMED WITH A ZINC RICH OR OTHERWISE RUST INHIBITIVE PRIMER SUCH AS TNEC SERIES V10, AND PAINTED WITH A CORROSION PROTECTING COATING SUCH AS TNEC SERIES 30.

REVISIONS:

JOB #	19.033
DRAWN BY:	KDN
CHECKED BY:	JAD
DATE:	11/21/19
SHEET #	

**S2**

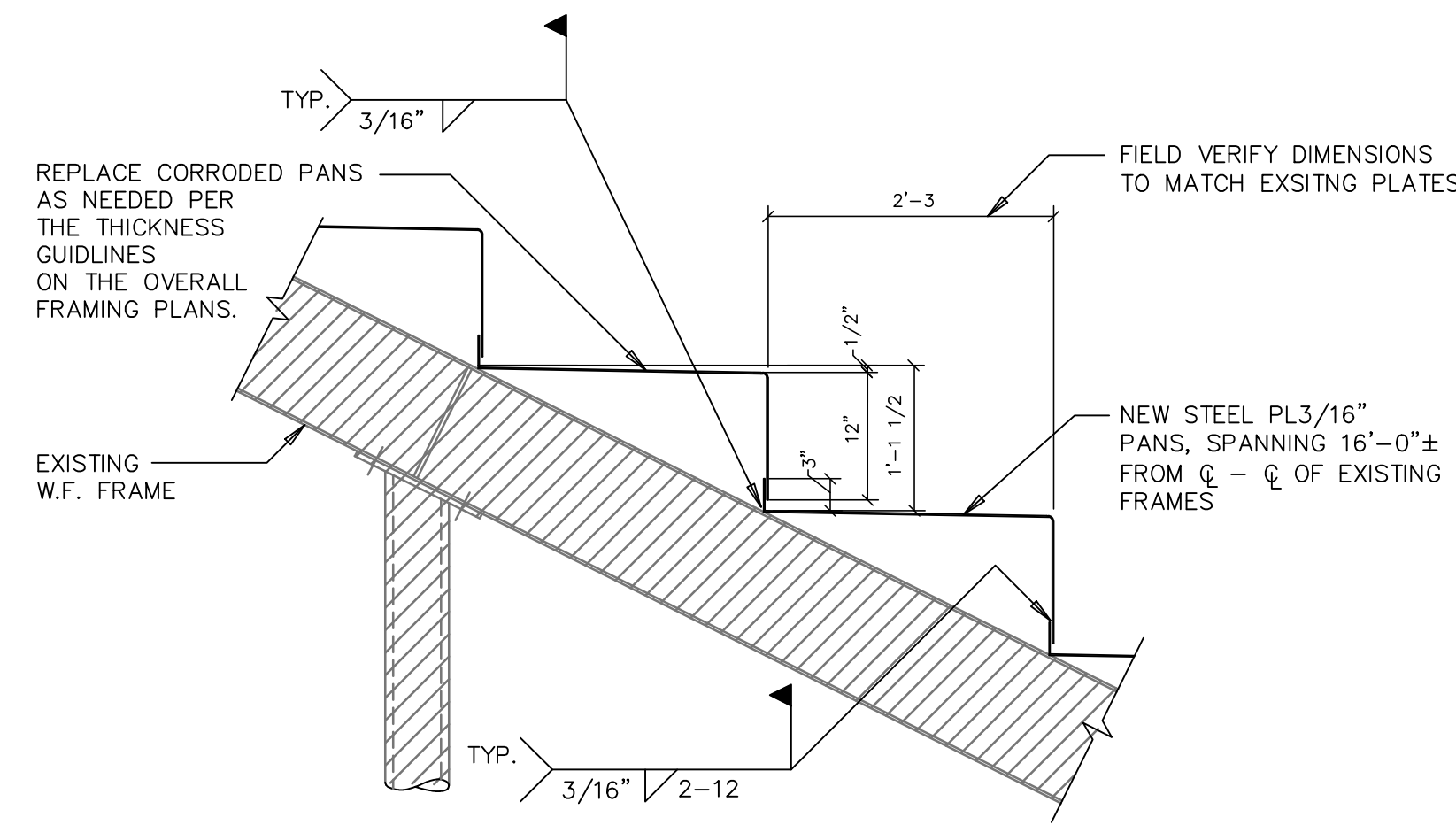

DETAIL A  
3/4" = 1'-0"

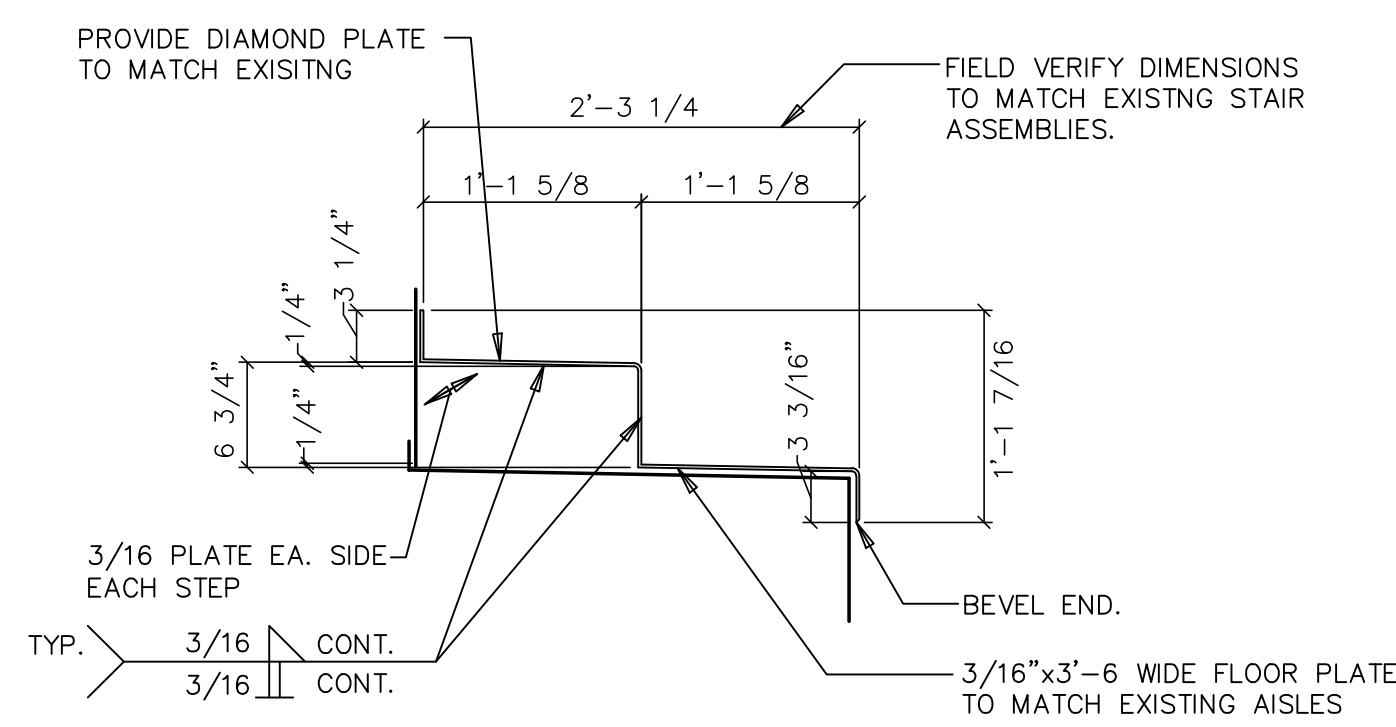

DETAIL B  
1" = 1'-0"

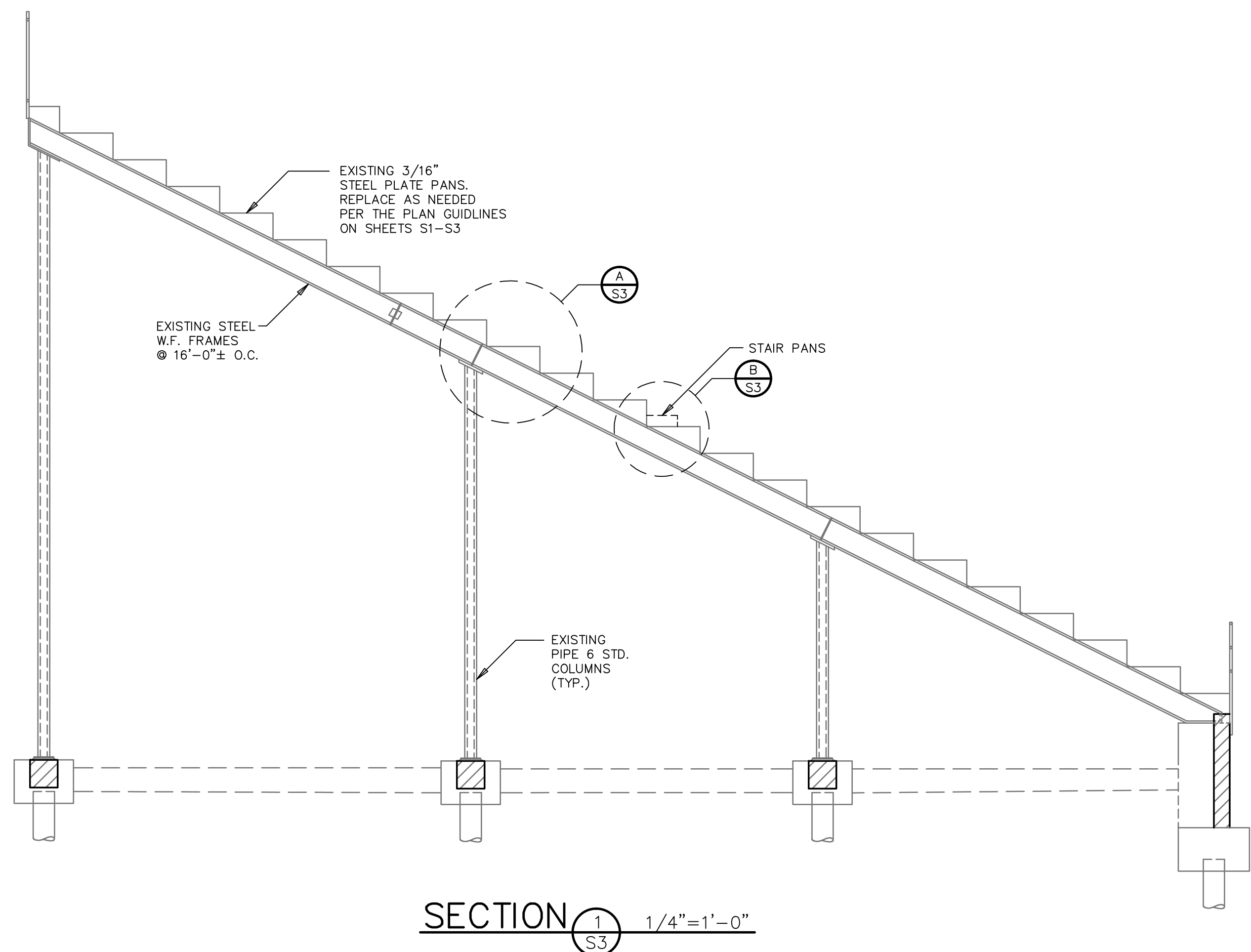

SECTION 1  
1/4" = 1'-0"

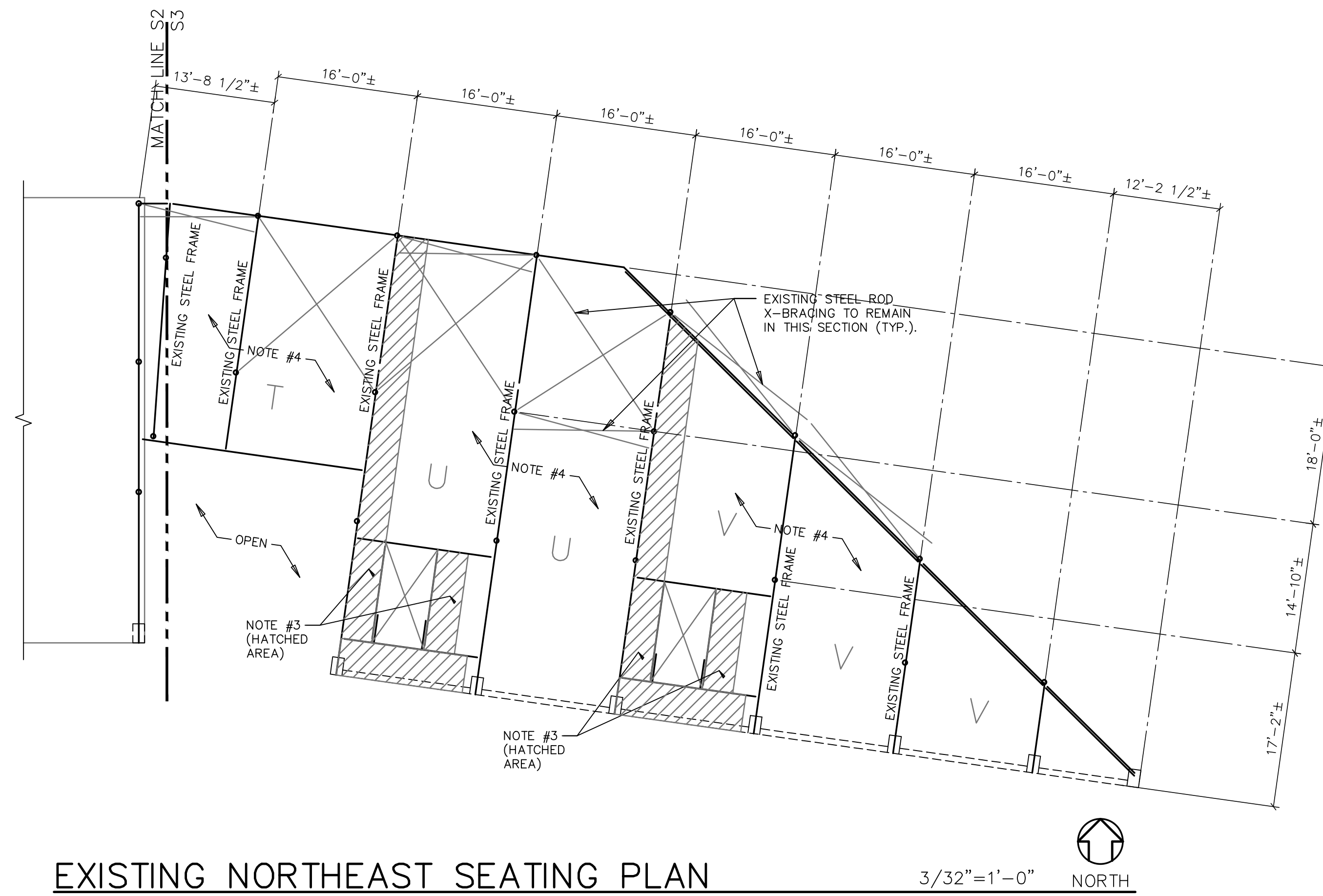

EXISTING NORTHEAST SEATING PLAN

- DIMENSIONS AND ORIENTATION OF SEATING STRUCTURE ARE APPROXIMATE. VERIFY DIMENSIONS AND CONDITIONS IN FIELD PRIOR TO FABRICATION AND CONSTRUCTION.
- EXISTING SEATING PANS CONSIST OF BENT 3/16" PLATE STEEL, PAINTED, SPANNING BETWEEN SLOPED STEEL FRAMES. STAIRS CONSIST OF STEEL DIAMOND PLATE TREADS, RISERS, AND SIDE CLOSURES INSTALLED ON TOP OF THE SEATING PANS.
- REPLACE STAIR TREAD AND RISER PLATES WITH NEW MATERIAL, WHERE CORROSION OF THE EXISTING STEEL RISERS AND TREADS HAS REDUCED THE PLATE THICKNESS TO LESS THAN 1/8" (ALTERNATIVE #1).
- REPLACE SEATING PANS EXHIBITING CORROSION WHERE THE PLATE THICKNESS HAS BEEN REDUCED TO LESS THAN 1/8" THICKNESS. LOCATIONS OF REDUCED THICKNESS HAVE BEEN SURVEYED BY THUNDER MOUNTAIN TESTING, AND ARE LISTED IN REPORTS DATED FEBRUARY 19 AND FEBRUARY 20, 2019. THESE REPORTS SHOULD BE USED TO IDENTIFY SEATING PANS THAT NEED TO BE REPLACED (ALTERNATIVE #2 - SECTIONS P-S).
- NEW STEEL MATERIAL SHALL BE PRIMED WITH A ZINC RICH OR OTHERWISE RUST INHIBITIVE PRIMER SUCH AS TNEC SERIES V10, AND PAINTED WITH A CORROSION PROTECTING COATING SUCH AS TNEC SERIES 30.

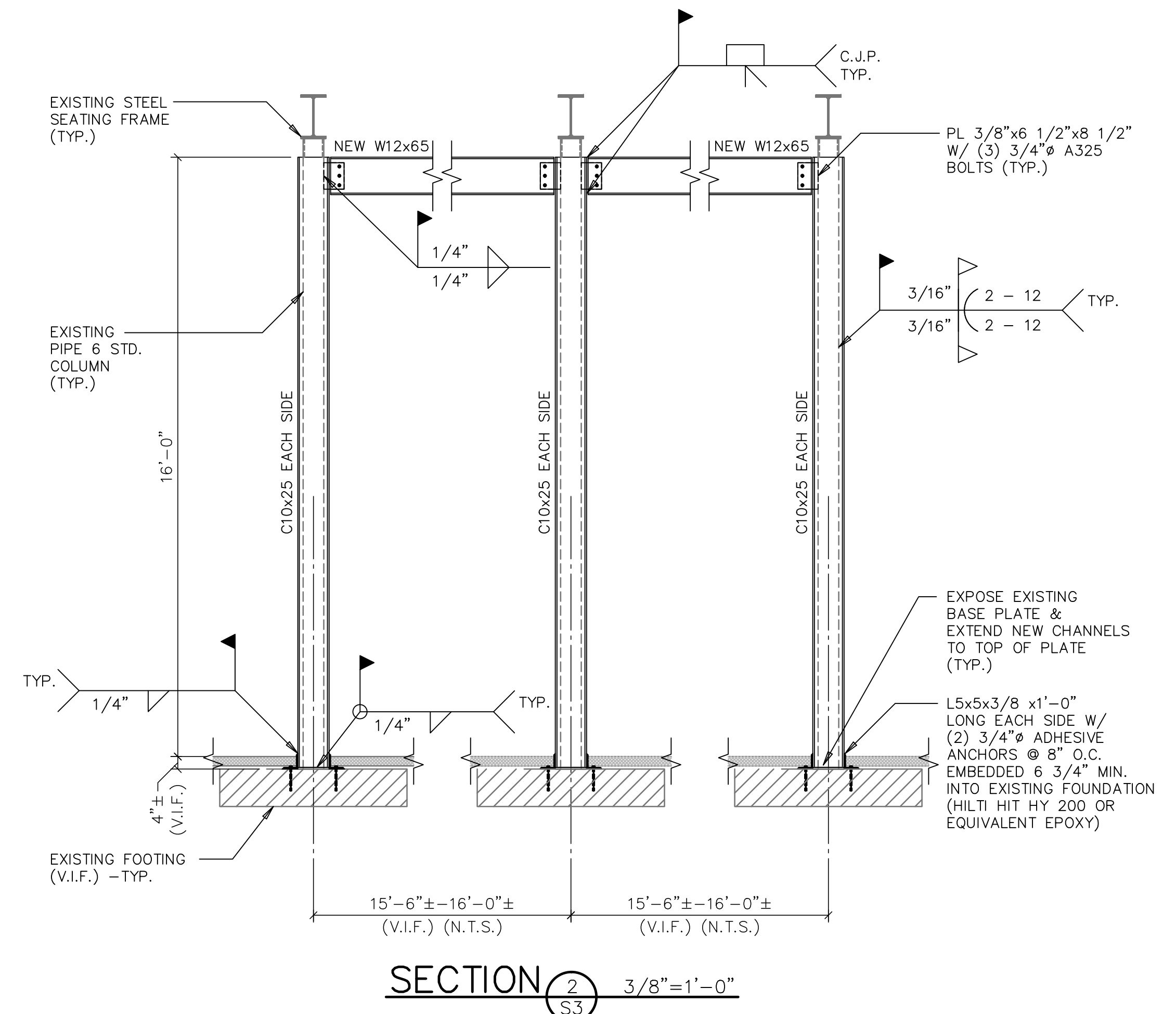

SECTION 2  
3/8" = 1'-0"

REVISIONS:

JOB #	19.033
DRAWN BY:	KDN, JDG
CHECKED BY:	JAD
DATE:	11/21/19

SHEET #

S3