

CHANGE ORDER

Number 1

Date: December 11, 2020
To: Bud's Signs
From: City of Grand Junction
Project: Wayfinding Signage
P.O.: 2020-00000547

It is agreed to modify the Contract for the Project as follows:

Increase the total number of signs required by an amount of up to 20 signs of any size, at a rate of \$2.25c per square foot, for the purpose of completing all designed signs per approved design proofs. There shall be no other amendment to the contract, and a final additional amount shall be subject to the final price calculation per these terms and the final design proofs. This amount shall not exceed a total cost of \$2000.

Contract Completion Date: December 30, 2020

Owner: City of Grand Junction

Prepared By:

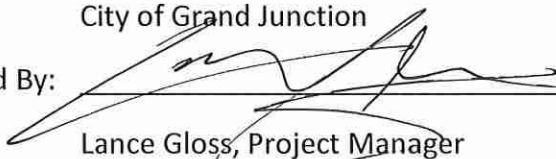

Lance Gloss, Project Manager

Date: 11 Dec 2020

Approved By:



Date:



CITY OF GRAND JUNCTION, COLORADO

CONTRACT

This CONTRACT made and entered into this 19th day of October, 2020 by and between the City of Grand Junction, Colorado, a government entity in the County of Mesa, State of Colorado, hereinafter in the Contract Documents referred to as the "Owner" and Bud's Signs of Grand Junction, Colorado, hereinafter in the Contract Documents referred to as the "Contractor."

WITNESSETH:

WHEREAS, the Owner advertised that sealed Responses would be received for furnishing all labor, tools, supplies, equipment, materials, and everything necessary and required for the Project described by the Contract Documents and known as RFP-4825-20-SH Wayfinding Signage.

WHEREAS, the Contract has been awarded to the above named Contractor by the Owner, and said Contractor is now ready, willing and able to perform the Work specified in the Notice of Award, in accordance with the Contract Documents;

NOW, THEREFORE, in consideration of the compensation to be paid the Contractor, the mutual covenants hereinafter set forth and subject to the terms hereinafter stated, it is mutually covenanted and agreed as follows:

ARTICLE 1

Contract Documents: It is agreed by the parties hereto that the following list of instruments, drawings, and documents which are attached hereto, bound herewith, or incorporated herein by reference constitute and shall be referred to either as the "Contract Documents" or the "Contract", and all of said instruments, drawings, and documents taken together as a whole constitute the Contract between the parties hereto, and they are fully a part of this agreement as if they were set out verbatim and in full herein:

The order of contract document governance shall be as follows:

- a. The body of this contract agreement
b. Solicitation Documents for the Project and all Addenda; RFP-4825-20-SH;
c. Contractors Response to the Solicitation
d. Work Change Requests (directing that changed work be performed);
e. Field Orders
f. Change Orders.

ARTICLE 2

Definitions: The clauses provided in the Solicitation apply to the terms used in the Contract and all the Contract Documents.

ARTICLE 3

Contract Work: The Contractor agrees to furnish all labor, tools, supplies, equipment, materials, and all that is necessary and required to complete design and manufacture signs associated with the Work described, set forth, shown, and included in this Contract and the Contract Documents as indicated in the Solicitation Document. L

The total number of signs to be designed and manufactured as are follows:

Quantity	Sign Size	Unit Price	Total Price
153	9 x 36*	\$112.00	\$17,136.00
64	24 x 36*	\$178.00	\$11,392.00
94	12 x 18**	\$42.00	\$3,948.00
Design and Workshops		\$7500.00	\$7,500.00
GRAND TOTAL FOR CONTRACT			\$39,976.00

Installation of signs shall be the responsibility of the City of Grand Junction.

* Indicates signs to be made with DOT reflective material.

** Indicates reflective material only on one section stating "You Are Here"

ARTICLE 4

Contract Time and Liquidated Damages: Contractor hereby agrees to commence Work under the Contract on or before the date specified in the Solicitation from the Owner, and to achieve Substantial Completion and Final Completion of the Work within the time or times specified in the Solicitation. In the event the Work is not completed in the times set forth and as agreed upon, the Contractor further agrees to pay Liquidated Damages to the Owner as set forth in the Solicitation. The Contractor acknowledges and recognizes the delays, expenses and difficulties involved in proving in a legal proceeding the actual losses suffered by the Owner if the work is not completed on time. Accordingly, instead of requiring any such proof, the Owner and the Contractor agree that as Liquidated Damages for delay, but not as a penalty, the Contractor shall pay to the Owner the amounts specified in the Solicitation.

ARTICLE 5

Contract Price and Payment Procedures: The Contractor shall accept as full and complete compensation for the performance and completion of all of the Work specified in the Contract Documents, the sum of **Thirty Nine Thousand Nine Hundred Seventy Six Dollars (\$39,976.00)**. The Contract Price shall not be modified except by Change Order or other written directive of the Owner. The Owner shall not issue a Change Order or other written directive which requires additional work to be performed, which work causes the aggregate amount payable under this Contract to exceed the amount appropriated for this Project, unless and until the Owner provides Contractor written assurance that lawful appropriations to cover the costs of the additional work have been made.

Unless otherwise provided in the Solicitation, monthly partial payments shall be made as the Work progresses. Applications for partial and Final Payment shall be prepared by the Contractor and approved by the Owner in accordance with the Solicitation.

Upon Final Completion of the Work under the Contract and before the Contractor shall receive final payment, the Owner shall publish at least twice in a newspaper of general circulation published in the County a notice that: 1) the Owner has accepted such Work as completed according to the Contract Documents; 2) the Contractor is entitled to final payment therefore; 3)

thirty days after the first publication, specifying the exact date, the Owner shall pay the full balance due under the Contract; and 4) persons having claims for labor, materials, team hire, sustenance, provisions, provender, or other supplies used or consumed by the Contractor or a subcontractor shall file a verified statement of the amount due and unpaid on account of such claim prior to the date specified for such payment. Nothing herein shall be construed as relieving the Contractor and the Sureties on the Contractor's Bonds from any claim or claims for work or labor done or materials or supplies furnished in the execution of the Contract.

ARTICLE 6

Bonds: Payment and Performance bonds are not required for this contract.

ARTICLE 7

Contract Binding: The Owner and the Contractor each binds itself, its partners, successors, assigns and legal representatives to the other party hereto in respect to all covenants, agreements and obligations contained in the Contract Documents. The Contract Documents constitute the entire agreement between the Owner and Contractor and may only be altered, amended or repealed by a duly executed written instrument. Neither the Owner nor the Contractor shall, without the prior written consent of the other, assign or sublet in whole or in part its interest under any of the Contract Documents and specifically, the Contractor shall not assign any moneys due or to become due without the prior written consent of the Owner.

ARTICLE 8

Severability: If any part, portion or provision of the Contract shall be found or declared null, void or unenforceable for any reason whatsoever by any court of competent jurisdiction or any governmental agency having the authority thereover, only such part, portion or provision shall be effected thereby and all other parts, portions and provisions of the Contract shall remain in full force and effect.

IN WITNESS WHEREOF, City of Grand Junction, Colorado, has caused this Contract to be subscribed in its behalf; and the Contractor has signed this Contract the day and the year first mentioned herein.

CITY OF GRAND JUNCTION

DocuSigned by:
By: Trent Prall
Trent Prall, Public Works Director

10/19/2020 | 16:28 MDT
Date

BUD'S SIGNS

DocuSigned by:
By: Paul Schritter
Paul Schritter, Sales Manager

10/19/2020 | 16:26 MDT
Date



**Purchase Order
No. 2020-00000547**

DATE 10/19/2020

Ph. (970) 244-1513

Fax

Ship To
City of Grand Junction
Public Works Administration
333 West Ave
GRAND JUNCTION, CO 81501

Bill To
City of Grand Junction
Public Works Administration
333 West Ave
GRAND JUNCTION, CO 81501

Vendor

VENDOR NO. 1343
Bud's Signs Incorporated
ACH
1040 Pitkin Avenue
Grand Junction, CO 81501
Phone: (970) 245-7700 Fax: (970) 243-0677

PAGE 1 of 1
SHIP VIA Vendor Delivery
DELIVER BY 11/16/2020
FREIGHT TERMS FOB Destination
Payment Terms: Net 30 Days
Buyer Name: Susan Jill Hyatt
Buyer Email: susanh@gjcity.org

Award RFP-4825-20-SH

QUANTITY	UNIT	DESCRIPTION	UNIT COST	TOTAL COST
1.0000	Each	CONTRACT SERVICES - Wayfinding Signage as negotiated in the contract. 201-330-010.8510 - Other Infrastructure Improvement 39,976.00 F2021-F202101	39,976.0000	\$39,976.00
PURCHASE ORDER TOTAL				\$39,976.00

Special Instructions: PURCHASE ORDER No. MUST APPEAR ON ALL INVOICES, SHIPPERS, PACKAGES, CORRESPONDENCE
Tax Exempt No. 98-03544

By: Susan J. Hyatt



**Request for Proposal
RFP-4825-20-SH**

WAYFINDING SIGNAGE

RESPONSES DUE:

September 23, 2020 prior to 2:30 P.M. Local Time

Accepting Electronic Responses Only

**Responses Only Submitted Through the Rocky Mountain E-Purchasing
System (RMEPS)**

www.bidnetdirect.com/colorado

**(Purchasing Representative does not have access or control of the vendor side of RMEPS.
If website or other problems arise during response submission, vendor MUST contact
RMEPS to resolve issue prior to the response deadline. 800-835-4603)**

PURCHASING REPRESENTATIVE:

Susan Hyatt
susanh@gjcity.org
970-244-1513

This solicitation has been developed specifically for a Request for Proposal intended to solicit competitive responses for this solicitation, and may not be the same as previous City of Grand Junction solicitations. All offerors are urged to thoroughly review this solicitation prior to submitting. Submittal by **FAX, EMAIL or HARD COPY IS NOT ACCEPTABLE** for this solicitation.

REQUEST FOR PROPOSAL

TABLE OF CONTENTS

Section

- 1.0 Administrative Information and Conditions for Submittal**
- 2.0 General Contract Terms and Conditions**
- 3.0 Insurance Requirements**
- 4.0 Specifications/Scope of Services**
- 5.0 Preparation and Submittal of Proposals**
- 6.0 Evaluation Criteria and Factors**
- 7.0 Solicitation Response Form**
- 8.0 Attachments**

REQUEST FOR PROPOSAL

SECTION 1.0: ADMINISTRATIVE INFORMATION & CONDITIONS FOR SUBMITTAL

- 1.1 Issuing Office:** This Request for Proposal (RFP) is issued by the City of Grand Junction (City). All contact regarding this RFP shall be directed to:

RFP Questions:

Susan Hyatt

susanh@gjcity.org

The City would like to remind all Contractors, Sub-Contractors, Vendors, Suppliers, Manufacturers, Service Providers, etc. that (with the exception of Pre-Bid or Site Visit Meetings) all questions, inquiries, comments, or communication pertaining to any formal solicitation (whether process, specifications, scope, etc.) must be directed (in writing) to the Purchasing Agent assigned to the project, or Purchasing Division. Direct communication with the City assigned Project Managers/Engineers is not appropriate for public procurement prior to award, and may result in disqualification.

- 1.2 Purpose:** The purpose of this RFP is to obtain proposals from qualified professional firms to provide and install Wayfinding Signage for the Grand Junction Public Works Department as described in Section 4.
- 1.3 Compliance:** All participating Offerors, by their signature hereunder, shall agree to comply with all conditions, requirements, and instructions of this RFP as stated or implied herein. Should the City omit anything from this packet which is necessary to the clear understanding of the requirements, or should it appear that various instructions are in conflict, the Offeror(s) shall secure instructions from the Purchasing Division prior to the date and time of the submittal deadline shown in this RFP.
- 1.4 Procurement Process:** Procurement processes shall be governed by the most current version of the City of Grand Junction [Purchasing Policy and Procedure Manual](#).
- 1.5 Submission:** Please refer to section 5.0 for what is to be included. Each proposal shall be submitted in electronic format only, and only through the Rocky Mountain E-Purchasing website, www.bidnetdirect.com/colorado. The uploaded response shall be a single PDF document with all required information included. This site offers both "free" and "paying" registration options that allow for full access of the City's documents and for electronic submission of proposals. (Note: "free" registration may take up to 24 hours to process. Please Plan accordingly.) For proper comparison and evaluation, the City requests that proposals be formatted as directed in Section 4.0 "Preparation and Submittal of Proposals." Submittals received that fail to follow this format may be ruled non-responsive. (Purchasing Representative does not have access or control of the vendor side of RMEPS. If website or other problems arise during response submission, vendor **MUST** contact RMEPS to resolve issue prior to the response deadline. **800-835-4603**)
- 1.6 Altering Proposals:** Any alterations made prior to opening date and time must be initialed by the signer of the proposal, guaranteeing authenticity. Proposals cannot be altered or amended after submission deadline.

- 1.7 Withdrawal of Proposal:** A proposal must be firm and valid for award and may not be withdrawn or canceled by the Offeror for sixty (60) days following the submittal deadline date, and only prior to award. The Offeror so agrees upon submittal of their proposal. After award this statement is not applicable.
- 1.8 Addenda:** All Questions shall be submitted in writing to the appropriate person as shown in Section 1.1. Any interpretations, corrections and changes to this RFP or extensions to the opening/receipt date shall be made by a written Addendum to the RFP by the City. Sole authority to authorize addenda shall be vested in the City of Grand Junction Purchasing Representative. Addenda will be issued electronically through the Rocky Mountain E-Purchasing website at www.bidnetdirect.com/colorado. Offerors shall acknowledge receipt of all addenda in their proposal. Addenda and solicitations are posted on the City's website, www.gjcity.org/business-and-economic-development/bids, for informational purposes.
- 1.9 Exception and Substitutions:** All proposals meeting the intent of this RFP shall be considered for award. Offerors taking exception to the specifications shall do so at their own risk. The Owner reserves the right to accept or reject any or all substitutions or alternatives. When offering substitutions and/or alternatives, Offeror must state these exceptions in the section pertaining to that area. Exception/substitution, if accepted, must meet or exceed the stated intent and/or specifications. The absence of such a list shall indicate that the Offeror has not taken exceptions, and if awarded a contract, shall hold the Offeror responsible to perform in strict accordance with the specifications or scope of work contained herein.
- 1.10 Confidential Material:** All materials submitted in response to this RFP shall ultimately become public record and shall be subject to inspection after contract award. **"Proprietary or Confidential Information"** is defined as any information that is not generally known to competitors and which provides a competitive advantage. Unrestricted disclosure of proprietary information places it in the public domain. Only submittal information clearly identified with the words **"Confidential Disclosure"** and uploaded as a separate document shall establish a confidential, proprietary relationship. Any material to be treated as confidential or proprietary in nature must include a justification for the request. The request shall be reviewed and either approved or denied by the City. If denied, the proposer shall have the opportunity to withdraw its entire proposal, or to remove the confidential or proprietary restrictions. Neither cost nor pricing information nor the total proposal shall be considered confidential or proprietary
- 1.11 Response Material Ownership:** All proposals become the property of the City upon receipt and shall only be returned to the proposer at the City's option. Selection or rejection of the proposal shall not affect this right. The City shall have the right to use all ideas or adaptations of the ideas contained in any proposal received in response to this RFP, subject to limitations outlined in the section titled "Confidential Material". Disqualification of a proposal does not eliminate this right.
- 1.12 Minimal Standards for Responsible Prospective Offerors:** A prospective Offeror must affirmably demonstrate their responsibility. A prospective Offeror must meet the following requirements:
- Have adequate financial resources, or the ability to obtain such resources as required.
 - Be able to comply with the required or proposed completion schedule.
 - Have a satisfactory record of performance.
 - Have a satisfactory record of integrity and ethics.

- Be otherwise qualified and eligible to receive an award and enter into a contract with the City.

- 1.13 Nonconforming Terms and Conditions:** A proposal that includes terms and conditions that do not conform to the terms and conditions of this Request for Proposal is subject to rejection as non-responsive. The City reserves the right to permit the Offeror to withdraw nonconforming terms and conditions from its proposal prior to a determination by the City of non-responsiveness based on the submission of nonconforming terms and conditions
- 1.14 Open Records:** All proposals shall be open for public inspection after the contract is awarded. Trade secrets and confidential information contained in the proposal so identified by offer as such shall be treated as confidential by the City to the extent allowable in the Open Records Act.
- 1.15 Sales Tax:** City of Grand Junction is, by statute, exempt from the State Sales Tax and Federal Excise Tax; therefore, all fees shall not include taxes.
- 1.16 Public Opening:** Proposals shall be opened in the City Hall Auditorium, 250 North 5th Street, Grand Junction, CO 81501, immediately following the proposal deadline. Offerors, their representatives and interested persons may be present. Only the names and locations on the proposing firms will be disclosed. **NOTE: Due to COVID-19 City Hall may be closed to the public. If so, following normal operating procedure the names and location of proposing firms will be posted on the City's website.**

SECTION 2.0: GENERAL CONTRACT TERMS AND CONDITIONS

- 2.1. Acceptance of RFP Terms:** A proposal submitted in response to this RFP shall constitute a binding offer. Acknowledgment of this condition shall be indicated on the Cover Letter by the Offeror or an officer of the Offeror legally authorized to execute contractual obligations. A submission in response to the RFP acknowledges acceptance by the Offeror of all terms and conditions, as set forth herein. An Offeror shall identify clearly and thoroughly any variations between its proposal and the City's RFP requirements. Failure to do so shall be deemed a waiver of any rights to subsequently modify the terms of performance, except as outlined or specified in the RFP.
- 2.2. Execution, Correlation, Intent, and Interpretations:** The Contract Documents shall be signed by the City and Contractor. By executing the contract, the Contractor represents that they have familiarized themselves with the local conditions under which the Work is to be performed, and correlated their observations with the requirements of the Contract Documents. The Contract Documents are complementary, and what is required by any one, shall be as binding as if required by all. The intention of the documents is to include all labor, materials, equipment, services and other items necessary for the proper execution and completion of the scope of work as defined in the technical specifications and drawings contained herein. All drawings, specifications and copies furnished by the City are, and shall remain, City property. They are not to be used on any other project.
- 2.3. Permits, Fees, & Notices:** The Contractor shall secure and pay for all permits, fees and licenses necessary for the proper execution and completion of the work. The Contractor shall give all notices and comply with all laws, ordinances, rules, regulations and orders of any public authority bearing on the performance of the work. If the Contractor observes that any of the Contract Documents are at variance in any respect, Contractor shall promptly

notify the Owner in writing, and any necessary changes shall be adjusted by change order/amendment. If the Contractor performs any work knowing it to be contrary to such laws, ordinances, rules and regulations, and without such notice to the Owner, Contractor shall assume full responsibility and shall bear all costs attributable.

- 2.4. Responsibility for those Performing the Work:** The Contractor shall be responsible to the Owner for the acts and omissions of all their employees and all other persons performing any of the work under a contract with the Contractor.
- 2.5. Use of the Site:** The Contractor shall confine operations at the site to areas permitted by law, ordinances, permits and the Contract Documents, and shall not unreasonably encumber the site with any materials or equipment.
- 2.6. Cleanup:** The Contractor at all times shall keep the premises free from accumulation of waste materials or rubbish caused by their operations. At the completion of work they shall remove all their waste materials and rubbish from and about the project, as well as all their equipment and surplus materials.
- 2.7. Payment & Completion:** The Contract Sum is stated in the Contract and is the total amount payable by the Owner to the Contractor for the performance of the work under the Contract Documents. Upon receipt of written notice that the work is ready for final inspection and acceptance and upon receipt of application for payment, the Owner's Project Manager will promptly make such inspection and, when Owner finds the work acceptable under the Contract Documents and the Contract fully performed, the Owner shall make payment in the manner provided in the Contract Documents. Partial payments will be based upon estimates, prepared by the Contractor, of the value of Work performed and materials placed in accordance with the Contract Documents.
- 2.8. Performance & Payment Bonds:** Payment and Performance bonds are not required for this contract.
- 2.9. Retention:** The Owner will deduct money from the partial payments in amounts considered necessary to protect the interest of the Owner and will retain this money until after completion of the entire contract. The amount to be retained from partial payments will be five (5) percent of the value of the completed work, and not greater than five (5) percent of the amount of the Contract. When the retainage has reached five (5) percent of the amount of the Contract no further retainage will be made and this amount will be retained until such time as final payment is made.
- 2.10. Liquidated Damages for Failure to Meet Project Completion Schedule:** If the Contractor does not achieve Final Completion by the required date, whether by neglect, refusal or any other reason, the parties agree and stipulate that the Contractor shall pay liquidated damages to the City for each such day that final completion is late. As provided elsewhere, this provision does not apply for delays caused by the City. The date for Final Completion may be extended in writing by the Owner.

The Contractor agrees that as a part of the consideration for the City's awarding of this Contract liquidated damages in the daily amount of **\$500.00** is reasonable and necessary to pay for the actual damages resulting from such delay. The parties agree that the real costs and injury to the City for such delay include hard to quantify items such as: additional engineering, inspection and oversight by the City and its agents; additional contract

administration; inability to apply the efforts of those employees to the other work of the City; perceived inefficiency of the City; citizens having to deal with the construction and the Work, rather than having the benefit of a completed Work, on time; inconvenience to the public; loss of reputation and community standing for the City during times when such things are very important and very difficult to maintain.

The Contractor must complete the Work and achieve final completion included under the Bid Schedule in the number of consecutive calendar days after the City gives its written Notice to Proceed. When the Contractor considers the entire Work ready for its intended use, Contractor shall certify in writing that the Work is substantially complete. In addition to the Work being substantially complete, Final Completion date is the date by which the Contractor shall have fully completed all clean-up, and all items that were identified by the City in the inspection for final completion. Unless otherwise stated in the Special Conditions, for purposes of this liquidated damages clause, the Work shall not be finished and the Contract time shall continue to accrue until the City gives its written Final Acceptance.

If the Contractor shall fail to pay said liquidated damages promptly upon demand thereof after having failed to achieve Final Completion on time, the City shall first look to any retainage or other funds from which to pay said liquidated damages; if retainage or other liquid funds are not available to pay said liquidated damages amounts, the Surety on the Contractor's Performance Bond and Payment Bond shall pay such liquidated damages. In addition, the City may withhold all, or any part of, such liquidated damages from any payment otherwise due the Contractor.

Liquidated damages as provided do not include any sums to reimburse the City for extra costs which the City may become obligated to pay on other contracts which were delayed or extended because of the Contractor's failure to complete the Work within the Contract Time. Should the City incur additional costs because of delays or extensions to other contracts resulting from the Contractor's failure of timely performance, the Contractor agrees to pay these costs that the City incurs because of the Contractor's delay, and these payments are separate from and in addition to any liquidated damages.

The Contractor agrees that the City may use its own forces or hire other parties to obtain Substantial or Final Completion of the work if the time of completion has elapsed and the Contractor is not diligently pursuing completion. In addition to the Liquidated Damages provided for, the Contractor agrees to reimburse the City for all expenses thus incurred.

2.11. Contingency/Force Account: Contingency/Force Account work will be authorized by the Owner's Project Manager and is defined as minor expenses to cover miscellaneous or unforeseen expenses related to the project. The expenses are not included in the Drawings, Specifications, or Scope of Work and are necessary to accomplish the scope of this contract. Contingency/Force Account Authorization will be directed by the Owner through an approved form. Contingency/Force Account funds are the property of the Owner and any Contingency/Force Account funds, not required for project completion, shall remain the property of the Owner. Contractor is not entitled to any Contingency/Force Account funds, that are not authorized by Owner or Owner's Project Manager.

2.12. Protection of Persons & Property: The Contractor shall comply with all applicable laws, ordinances, rules, regulations and orders of any public authority having jurisdiction for the safety of persons or property or to protect them from damage, injury or loss. Contractor shall erect and maintain, as required by existing safeguards for safety and protection, and all reasonable precautions, including posting danger signs or other warnings against

hazards promulgating safety regulations and notifying owners and users of adjacent utilities. When or where any direct or indirect damage or injury is done to public or private property by or on account of any act, omission, neglect, or misconduct by the Contractor in the execution of the work, or in consequence of the non-execution thereof by the Contractor, they shall restore, at their own expense, such property to a condition similar or equal to that existing before such damage or injury was done, by repairing, rebuilding, or otherwise restoring as may be directed, or it shall make good such damage or injury in an acceptable manner.

- 2.13. Changes in the Work:** The Owner, without invalidating the contract, may order changes in the work within the general scope of the contract consisting of additions, deletions or other revisions. All such changes in the work shall be authorized by Change Order and shall be executed under the applicable conditions of the contract documents. A Change Order is a written order to the Contractor signed by the Owner issued after the execution of the contract, authorizing a change in the work or an adjustment in the contract sum or the contract time.
- 2.14. Minor Changes in the Work:** The Owner shall have authority to order minor changes in the work not involving an adjustment in the contract sum or an extension of the contract time and not inconsistent with the intent of the contract documents.
- 2.15. Uncovering & Correction of Work:** The Contractor shall promptly correct all work found by the Owner as defective or as failing to conform to the contract documents. The Contractor shall bear all costs of correcting such rejected work, including the cost of the Owner's additional services thereby made necessary. The Owner shall give such notice promptly after discovering of condition. All such defective or non-conforming work under the above paragraphs shall be removed from the site where necessary and the work shall be corrected to comply with the contract documents without cost to the Owner.
- 2.16. Acceptance Not Waiver:** The City's acceptance or approval of any work furnished hereunder shall not in any way relieve the proposer of their present responsibility to maintain the high quality, integrity and timeliness of his work. The City's approval or acceptance of, or payment for, any services shall not be construed as a future waiver of any rights under this Contract, or of any cause of action arising out of performance under this Contract.
- 2.17. Change Order/Amendment:** No oral statement of any person shall modify or otherwise change, or affect the terms, conditions or specifications stated in the resulting contract. All change orders/amendments to the contract shall be made in writing by the Owner Purchasing Division.
- 2.18. Assignment:** The Offeror shall not sell, assign, transfer or convey any contract resulting from this RFP, in whole or in part, without the prior written approval from the City.
- 2.19. Compliance with Laws:** Proposals must comply with all Federal, State, County and local laws governing or covering this type of service and the fulfillment of all ADA (Americans with Disabilities Act) requirements. Contractor hereby warrants that it is qualified to assume the responsibilities and render the services described herein and has all requisite corporate authority and professional licenses in good standing, required by law.

- 2.20. Debarment/Suspension:** The Contractor hereby certifies that the Contractor is not presently debarred, suspended, proposed for debarment, declared ineligible, or voluntarily excluded from covered transactions by any Governmental department or agency.
- 2.21. Confidentiality:** All information disclosed by the City to the Contractor for the purpose of the work to be done or information that comes to the attention of the Contractor during the course of performing such work is to be kept strictly confidential.
- 2.22. Conflict of Interest:** No public official and/or City employee shall have interest in any contract resulting from this RFP.
- 2.23. Contract:** This Request for Proposal, submitted documents, and any negotiations, when properly accepted by the City, shall constitute a contract equally binding between the City and Offeror. The contract represents the entire and integrated agreement between the parties hereto and supersedes all prior negotiations, representations, or agreements, either written or oral, including the Proposal documents. The contract may be amended or modified with Change Orders, Field Orders, or Amendment.
- 2.24. Cancellation of Solicitation:** Any solicitation may be canceled by the City or any solicitation response by a vendor may be rejected in whole or in part when it is in the best interest of the City.
- 2.25. Project Manager/Administrator:** The Project Manager, on behalf of the Owner, shall render decisions in a timely manner pertaining to the work proposed or performed by the Offeror. The Project Manager shall be responsible for approval and/or acceptance of any related performance of the Scope of Work.
- 2.26. Contract Termination:** This contract shall remain in effect until any of the following occurs: (1) contract expires; (2) completion of services; (3) acceptance of services or, (4) for convenience terminated by either party with a written *Notice of Cancellation* stating therein the reasons for such cancellation and the effective date of cancellation at least thirty days past notification.
- 2.27. Employment Discrimination:** During the performance of any services per agreement with the City, the Offeror, by submitting a Proposal, agrees to the following conditions:
- 2.27.1.** The Offeror shall not discriminate against any employee or applicant for employment because of race, religion, color, sex, age, disability, citizenship status, marital status, veteran status, sexual orientation, national origin, or any legally protected status except when such condition is a legitimate occupational qualification reasonably necessary for the normal operations of the Offeror. The Offeror agrees to post in conspicuous places, visible to employees and applicants for employment, notices setting forth the provisions of this nondiscrimination clause.
- 2.27.2.** The Offeror, in all solicitations or advertisements for employees placed by or on behalf of the Offeror, shall state that such Offeror is an Equal Opportunity Employer.
- 2.27.3.** Notices, advertisements, and solicitations placed in accordance with federal law, rule, or regulation shall be deemed sufficient for the purpose of meeting the requirements of this section.

- 2.28. Immigration Reform and Control Act of 1986 and Immigration Compliance:** The Offeror certifies that it does not and will not during the performance of the contract employ illegal alien workers or otherwise violate the provisions of the Federal Immigration Reform and Control Act of 1986 and/or the immigration compliance requirements of State of Colorado C.R.S. § 8-17.5-101, *et seq.* (House Bill 06-1343).
- 2.29. Ethics:** The Offeror shall not accept or offer gifts or anything of value nor enter into any business arrangement with any employee, official, or agent of the City.
- 2.30. Failure to Deliver:** In the event of failure of the Offeror to deliver services in accordance with the contract terms and conditions, the City, after due oral or written notice, may procure the services from other sources and hold the Offeror responsible for any costs resulting in additional purchase and administrative services. This remedy shall be in addition to any other remedies that the City may have.
- 2.31. Failure to Enforce:** Failure by the Owner at any time to enforce the provisions of the contract shall not be construed as a waiver of any such provisions. Such failure to enforce shall not affect the validity of the contract or any part thereof or the right of the Owner to enforce any provision at any time in accordance with its terms.
- 2.32. Force Majeure:** The Offeror shall not be held responsible for failure to perform the duties and responsibilities imposed by the contract due to legal strikes, fires, riots, rebellions, and acts of God beyond the control of the Offeror, unless otherwise specified in the contract.
- 2.33. Indemnification:** Offeror shall defend, indemnify and save harmless the City and all its officers, employees, insurers, and self-insurance pool, from and against all liability, suits, actions, or other claims of any character, name and description brought for or on account of any injuries or damages received or sustained by any person, persons, or property on account of any negligent act or fault of the Offeror, or of any Offeror's agent, employee, subcontractor or supplier in the execution of, or performance under, any contract which may result from proposal award. Offeror shall pay any judgment with cost which may be obtained against the City growing out of such injury or damages.
- 2.34. Independent Firm:** The Offeror shall be legally considered an Independent Firm and neither the Firm nor its employees shall, under any circumstances, be considered servants or agents of the Owner. The Owner shall be at no time legally responsible for any negligence or other wrongdoing by the Firm, its servants, or agents. The Owner shall not withhold from the contract payments to the Firm any federal or state unemployment taxes, federal or state income taxes, Social Security Tax or any other amounts for benefits to the Firm. Further, the Owner shall not provide to the Firm any insurance coverage or other benefits, including Workers' Compensation, normally provided by the Owner for its employees.
- 2.35. Ownership:** All plans, prints, designs, concepts, etc., shall become the property of the Owner.
- 2.36. Oral Statements:** No oral statement of any person shall modify or otherwise affect the terms, conditions, or specifications stated in this document and/or resulting agreement. All modifications to this request and any agreement must be made in writing by the City.

- 2.37. Patents/Copyrights:** The Offeror agrees to protect the Owner from any claims involving infringements of patents and/or copyrights. In no event shall the Owner be liable to the Offeror for any/all suits arising on the grounds of patent(s)/copyright(s) infringement. Patent/copyright infringement shall null and void any agreement resulting from response to this RFP.
- 2.38. Remedies:** The Offeror and City agree that both parties have all rights, duties, and remedies available as stated in the Uniform Commercial Code.
- 2.39. Venue:** Any agreement as a result of this RFP shall be deemed to have been made in, and shall be construed and interpreted in accordance with, the laws of the City of Grand Junction, Mesa County, Colorado.
- 2.40. Expenses:** Expenses incurred in preparation, submission and presentation of this RFP are the responsibility of the company and cannot be charged to the City.
- 2.41. Sovereign Immunity:** The Owner specifically reserves its right to sovereign immunity pursuant to Colorado State Law as a defense to any action arising in conjunction to this agreement.
- 2.42. Public Funds/Non-Appropriation of Funds:** Funds for payment have been provided through the City's budget approved by the City Council/Board of County Commissioners for the stated fiscal year only. State of Colorado statutes prohibit the obligation and expenditure of public funds beyond the fiscal year for which a budget has been approved. Therefore, anticipated orders or other obligations that may arise past the end of the stated City's fiscal year shall be subject to budget approval. Any contract will be subject to and must contain a governmental non-appropriation of funds clause.
- 2.43. Collusion Clause:** Each Offeror by submitting a proposal certifies that it is not party to any collusive action or any action that may be in violation of the Sherman Antitrust Act. Any and all proposals shall be rejected if there is evidence or reason for believing that collusion exists among the proposers. The City may or may not, at the discretion of the City Purchasing Representative, accept future proposals for the same service or commodities for participants in such collusion.
- 2.44. Gratuities:** The Contractor certifies and agrees that no gratuities or kickbacks were paid in connection with this contract, nor were any fees, commissions, gifts or other considerations made contingent upon the award of this contract. If the Contractor breaches or violates this warranty, the City may, at their discretion, terminate this contract without liability to the City.
- 2.45. OSHA Standards:** All Offerors agree and warrant that services performed in response to this invitation shall conform to the standards declared by the US Department of Labor under the Occupational Safety and Health Act of 1970 (OSHA). In the event the services do not conform to OSHA Standards, the Owner may require the services to be redone at no additional expense to the Owner.
- 2.46. Performance of the Contract:** The City reserves the right to enforce the performance of the contract in any manner prescribed by law or deemed to be in the best interest of the City in the event of breach or default of resulting contract award.

- 2.47. Benefit Claims:** The Owner shall not provide to the Contractor any insurance coverage or other benefits, including Worker's Compensation, normally provided by the Owner for its employees.
- 2.48. Default:** The Owner reserves the right to terminate the contract immediately in the event the Contractor fails to meet delivery or completion schedules, or otherwise perform in accordance with the accepted proposal. Breach of contract or default authorizes the Owner to purchase like services elsewhere and charge the full increase in cost to the defaulting Contractor.
- 2.49. Multiple Offers:** Proposers must determine for themselves which product or service to offer. If said proposer chooses to submit more than one offer, THE ALTERNATE OFFER must be clearly marked "Alternate Proposal". The Owner reserves the right to make award in the best interest of the Owner.
- 2.50. Cooperative Purchasing:** Purchases as a result of this solicitation are primarily for the City. Other governmental entities may be extended the opportunity to utilize the resultant contract award with the agreement of the successful provider and the participating agencies. All participating entities will be required to abide by the specifications, terms, conditions and pricings established in this Proposal. The quantities furnished in this proposal document are for only the City. It does not include quantities for any other jurisdiction. The City will be responsible only for the award for our jurisdiction. Other participating entities will place their own awards on their respective Purchase Orders through their purchasing office or use their purchasing card for purchase/payment as authorized or agreed upon between the provider and the individual entity. The City accepts no liability for payment of orders placed by other participating jurisdictions that choose to piggy-back on our solicitation. Orders placed by participating jurisdictions under the terms of this solicitation will indicate their specific delivery and invoicing instructions.
- 2.51. Definitions:**
- 2.51.1.** "Offeror" and/or "Proposer" refers to the person or persons legally authorized by the Consultant to make an offer and/or submit a response (fee) proposal in response to the Owner's RFP.
 - 2.51.2.** The term "Work" includes all labor, materials, equipment, and/or services necessary to produce the requirements of the Contract Documents.
 - 2.51.3.** "Contractor" is the person, organization, firm or consultant identified as such in the Agreement and is referred to throughout the Contract Documents. The term Contractor means the Contractor or his authorized representative. The Contractor shall carefully study and compare the General Contract Conditions of the Contract, Specification and Drawings, Scope of Work, Addenda and Modifications and shall at once report to the Owner any error, inconsistency or omission he may discover. Contractor shall not be liable to the Owner for any damage resulting from such errors, inconsistencies or omissions. The Contractor shall not commence work without clarifying Drawings, Specifications, or Interpretations.
 - 2.51.4.** "Sub-Contractor" is a person or organization who has a direct contract with the Contractor to perform any of the work at the site. The term sub-contractor is referred to throughout the contract documents and means a sub-contractor or his authorized representative.

2.52. Public Disclosure Record: If the Proposer has knowledge of their employee(s) or sub-proposers having an immediate family relationship with an City employee or elected official, the proposer must provide the Purchasing Representative with the name(s) of these individuals. These individuals are required to file an acceptable "Public Disclosure Record", a statement of financial interest, before conducting business with the City.

2.53. Keep Jobs in Colorado Act: Contractor shall be responsible for ensuring compliance with Article 17 of Title 8, Colorado Revised Statutes requiring 80% Colorado labor to be employed on public works projects. Contractor shall, upon reasonable notice provided by the Owner, permit the Owner to inspect documentation of identification and residency required by C.R.S. §8-17-101(2)(a). If Contractor claims it is entitled to a waiver pursuant to C.R.S. §8-17-101(1), Contractor shall state that there is insufficient Colorado labor to perform the work such that compliance with Article 17 would create an undue burden that would substantially prevent a project from proceeding to completion, and shall include evidence demonstrating the insufficiency and undue burden in its response.

Unless expressly granted a waiver by the Owner pursuant to C.R.S. §8-17-101(1), Contractor shall be responsible for ensuring compliance with Article 17 of Title 8, Colorado Revised Statutes requiring 80% Colorado labor to be employed on public works projects. Contractor shall, upon reasonable notice provided by the Owner, permit the Owner to inspect documentation of identification and residency required by C.R.S. §8-17-101(2)(a).

2.53.1. "Public Works project" is defined as:

- (a) any construction, alteration, repair, demolition, or improvement of any land, building, structure, facility, road, highway, bridge, or other public improvement suitable for and intended for use in the promotion of the public health, welfare, or safety and any maintenance programs for the upkeep of such projects
- (b) for which appropriate or expenditure of moneys may be reasonably expected to be \$500,000.00 or more in the aggregate for any fiscal year
- (c) except any project that receives federal moneys.

SECTION 3.0: INSURANCE REQUIREMENTS

Insurance Requirements: The selected Contractor agrees to procure and maintain, at its own cost, policy(s) of insurance sufficient to insure against all liability, claims, demands, and other obligations assumed by the Contractor pursuant to this Section. Such insurance shall be in addition to any other insurance requirements imposed by this Contract or by law. The Contractor shall not be relieved of any liability, claims, demands, or other obligations assumed pursuant to this Section by reason of its failure to procure or maintain insurance in sufficient amounts, durations, or types. Contractor shall procure and maintain and, if applicable, shall cause any Subcontractor of the Contractor to procure and maintain insurance coverage listed below. Such coverage shall be procured and maintained with forms and insurers acceptable to the Owner. In the case of any claims-made policy, the necessary retroactive dates and extended reporting periods shall be procured to maintain such continuous coverage. Minimum coverage limits shall be as indicated below unless specified otherwise:

(a) **Worker Compensation:** Contractor shall comply with all State of Colorado Regulations concerning Workers' Compensation insurance coverage.

(b) **General Liability insurance** with minimum limits of:

ONE MILLION DOLLARS (\$1,000,000) each occurrence and
ONE MILLION DOLLARS (\$1,000,000) per job aggregate.

The policy shall be applicable to all premises and operations. The policy shall include coverage for bodily injury, broad form property damage (including completed operations), personal injury (including coverage for contractual and employee acts), blanket contractual, products, and completed operations. The policy shall include coverage for explosion, collapse, and underground hazards. The policy shall contain a severability of interests provision.

(c) Comprehensive Automobile Liability insurance with minimum limits for bodily injury and property damage of not less than:

ONE MILLION DOLLARS (\$1,000,000) each occurrence and
ONE MILLION DOLLARS (\$1,000,000) aggregate

(d) Professional Liability & Errors and Omissions Insurance policy with a minimum of:

ONE MILLION DOLLARS (\$1,000,000) per claim

This policy shall provide coverage to protect the contractor against liability incurred as a result of the professional services performed as a result of responding to this Solicitation.

With respect to each of Contractors owned, hired, or non-owned vehicles assigned to be used in performance of the Work. The policy shall contain a severability of interests provision. The policies required by paragraph (b) above shall be endorsed to include the Owner, and the Owner's officers and employees as additional insureds. Every policy required above shall be primary insurance, and any insurance carried by the Owner, its officers, or its employees, or carried by or provided through any insurance pool of the Owner, shall be excess and not contributory insurance to that provided by Bidder. No additional insured endorsement to any required policy shall contain any exclusion for bodily injury or property damage arising from completed operations. The Bidder shall be solely responsible for any deductible losses under any policy required above.

SECTION 4.0: SPECIFICATIONS/SCOPE OF SERVICES

4.1 General: The City of Grand Junction, Colorado (City) is seeking proposals from qualified Contractors for design and installation of bike/ped wayfinding signage on routes throughout the city.

4.2 Background

4.2.1 Community Context: The Grand Valley of Mesa County, Colorado is the largest population center between the Denver, Metropolitan Area (250 miles east) and the Salt Lake City Metropolitan Area (270 miles west). It serves as the economic and service center for communities in Western Colorado and Eastern Utah. The urbanized area of the Grand Valley is comprised of four major population centers: Clifton, Fruita, Grand Junction, and Palisade. Grand Junction and the Grand Valley have an increasingly robust multimodal transportation network, the centerpiece of which is the Colorado Riverfront Trail running almost continuously from Palisade through Grand Junction and past Fruita to the small town of Loma. The City of Grand Junction also maintains a network of on-street and off-street bike/ped facilities, many of which connect directly to the Riverfront Trail.

4.2.2 Project Context: The City of Grand Junction, in cooperation with neighboring jurisdictions and local stakeholders, has been developing a proposal for wayfinding signage for over two years. Interest in a wayfinding program for the Grand Valley has persisted for more than two decades. In August of 2020, the City of Grand Junction was awarded a grant through the Colorado Department of Transportation (CDOT), called Revitalizing Main Streets, which has provided significant funding for this effort. Background materials relating to these preparatory efforts, particularly those produced by the City of Grand Junction Urban Trails Committee (UTC), establish many of the underlying needs and ideal product design elements for this project.

4.3 Project Overview

4.3.1 Purpose: The purpose of this project is to implement the first iteration of a comprehensive wayfinding system for Grand Junction, in cooperation with other Grand Valley jurisdictions. The aim is to finalize design for, and install, essential directional signage along six routes, including the Colorado Riverfront Trail.

4.3.2 Required Components: The project requires finalization of a sign design, finalization of sign locations, and installation of signs and associated hardware. Sign design (**Exhibit B**) and sign locations (**Exhibit C**) have already been drafted by City of Grand Junction and volunteers associated with the City's Urban Trails Committee (UTC). The Contractor shall provide a minimum of three final design options for review and selection by the City of Grand Junction. The Contractor shall manufacture the signs and shall supply all crews, equipment, and materials for the production and installation of signs.

4.3.3 Area of Work: All work shall take place within City of Grand Junction city limits. The Contractor may be required to cooperate with the City of Grand Junction to coordinate with other relevant authorities, including but not limited to Colorado Parks and Wildlife, Colorado Department of Transportation, Grand Junction Downtown Development Authority, One Riverfront Foundation, and Mesa County. The sign designs must be granted to the ownership of the City of Grand Junction for future use and for sharing with other Grand Valley jurisdictions to allow for unified design.

4.4 Specifications/Scope of Work: The awarded Contractor shall provide finalize design and locations of signs and shall install all sign hardware.

4.4.1 Minimum Specifications

The final scope of services will be the result of negotiations between the City and the selected Contractor as to how to best meet the City's goals for the planning process. The proposal should include, but is not limited to, recommendations for the following:

4.4.1.1 Design

- a. Present at least three draft design options of sufficient variety for selection by the City of Grand Junction
- b. Participate in up to two workshops for vetting of final sign designs with the City of Grand Junction and community stakeholders
- c. Develop design files based on final sign designs for each location, requiring unique directional information on all or most signs
- d. Produce signs that meet the following design specifications:
 - i. Indicate relevant destinations (**Exhibit D**) with direction and distance
 - ii. Indicate applicability to bicycles (and, if possible, pedestrians)
 - iii. Indicate, by color and language, the route with which each sign is associated
 - iv. Include, or allow for later inclusion, the City of Grand Junction logo
 - v. Conform to the Manual on Uniform Traffic Control Devices (MUTCD)
 - vi. Be attractive and uncluttered

4.4.1.2 Locations

- a. Evaluate and finalize the proposed locations of wayfinding signs

4.4.1.3 Production

- a. Print and manufacture all signs
- b. Provide posts and other hardware necessary for installation of signs

4.4.1.4 Installation

- a. Provide crews, equipment, and all other necessary supplies for installation of signs
- b. Install, in a timely manner, all signs as detailed in the attached spreadsheet (**Exhibit A**) at or near the locations identified in the attached map (**Exhibit C**)

4.4.1.5 Rights and Design Files

- a. Grant all rights sign designs and use thereof to the City of Grand Junction and,
- b. Provide all design and mapping files used in the finalization of sign designs and sign locations

4.4.2 Community Outreach: The Contractor shall participate in up to two (2) workshops with community stakeholders and the City of Grand Junction with the aim of finalizing sign designs and locations for installation.

4.4.3 City Staff: The Contractor shall communicate openly with City of Grand Junction staff throughout the project to attend to evolving demands within the project scope. The Contractor shall meet in person with City staff up to three (3) times to verify progress toward project outcomes and ensure alignment of work with permitting requirements and other needs associated with improvements to City infrastructure.

4.4.4 Other Specifications: The product shall be of a quality and durability that is suitable for long-term deployment within the City of Grand Junction. Materials shall be consistent with the needs and standards of a municipal infrastructure project. The Contractor shall provide Geographic Information Systems (GIS) based (or similar) map of sign locations to inform the finalized sign locations.

4.5 Owner's Responsibilities: City of Grand Junction staff will assist in providing information, maps, GIS data and other community-generated materials such as previous studies. Staff may also assist with developing a list of, coordinating meetings with, and distributing draft materials to relevant persons and agencies in the Grand Valley.

4.6 Proposal Content

4.6.1 Project Team: The proposal should respond directly to all elements of this Request. The proposal should include a cover letter as well as resumes for key employees of the Contractor and for any subcontractors. The proposal must also identify project personnel who will be responsible for and in charge of the work, as well as a review of current project workload and availability of project team members.

4.6.2 Team Qualifications: The proposal should also include information on the Contractor's unique qualifications and/or capabilities. Examples of similar projects including client contact information, project budget, completion date, and project team members are a required component of the proposal.

4.6.3 Timeline and Budget: The proposal should include the project timeline, including sub-timelines for major tasks proposed. A proposed budget or multiple budget scenarios that clearly correspond to the proposal narrative must be included in the proposal.

4.7 Minimum Mandatory Qualifications of Offeror: The Contractor's project manager(s) shall have at least 5 years of signage design experience and at least 5 years of signage installation experience. The Contractor's team shall include at least one (1) sign contractor licensed within the City of Grand Junction, and that individual shall be charged with supervision of signage installation. The ideal Contractor shall have participated in, or managed, a signage project with emphasis on bicycle/pedestrian wayfinding on a municipal, county, or regional scale.

4.8 Evaluation Criteria

4.8.1 Recommendation: Project staff from the City of Grand Junction Community Development Department and City Manager's Office will begin the evaluation process. Firms will be selected based upon their proposal's alignment with this Request and the qualifications presented by proposing Contractors. Selected firms will be interviewed by a committee composed of City staff. Contractors selected for interviews should be prepared to discuss, among other things, their approaches to implementing a wayfinding signage program, availability for the project, and experiences with similar projects.

4.8.2 Selection: Final selection of the Contractors will be made by a decision of the Director of the City of Grand Junction Department of Public Works.

4.9 RFP Tentative Time Schedule:

- Request for Proposal available on or about: August 31, 2020
- Inquiry deadline, no questions after this date: September 10, 2020
- Addendum posted: September 15, 2020
- Submittal deadline for proposals: September 23, 2020
- Final selection: September 25, 2020
- Contract execution: September 30, 2020
- Work begins: October 5, 2020
- Target Project Completion Date: November 30, 2020

4.10 Questions Regarding Scope of Services:

Susan Hyatt

susanh@gjcity.org

4.11 Contract: The initial contract period shall be from October 1 through November 30, 2020 and may be renewed for a period up to 3 months, as mutually agreed by the City and the Consultant. All awards and extensions are subject to annual appropriation of funds.

SECTION 5.0: PREPARATION AND SUBMITTAL OF PROPOSALS

Submission: Each proposal shall be submitted in electronic format only, and only through the BidNet website, www.bidnetdirect.com/colorado. This site offers both "free" and "paying" registration options that allow for full access of the City's documents and for electronic submission of proposals. (Note: "free" registration may take up to 24 hours to process. Please Plan accordingly.) (Purchasing Representative does not have access or control of the vendor side of RMEPS. If website or other problems arise during response submission, vendor **MUST** contact RMEPS to resolve issue prior to the response deadline; **800-835-4603**). For proper comparison and evaluation, the City requests that proposals be formatted as directed. The uploaded response to this RFP shall be a single PDF document with all required information included. Offerors are required to indicate their interest in this Project, show their specific experience and address their capability to perform the Scope of Services in the Time Schedule as set forth herein. For proper comparison and evaluation, the City requires that proposals be formatted **A to G**.

- A. Cover Letter:** Cover letter shall be provided which explains the Firm's interest in the project. The letter shall contain the name/address/phone number/email of the person who will serve as the firm's principal contact with City's Contract Administrator and shall identify individual(s) who will be authorized to make presentations on behalf of the firm. The statement shall bear the signature of the person having proper authority to make formal commitments on behalf of the firm. By submitting a response to this solicitation the Contractor agrees to all requirements herein.
- B. Qualifications/Experience/Credentials:** Proposers shall provide their qualifications for consideration as a contract provider to the City of Grand Junction and include prior experience in similar projects, as follows:
1. Provide the name of the project manager for this assignment, including and overview of their experience as project manager for other similar assignments and amount of time this person is expected to spend on the project.
 2. Provide the names and resumes of key personnel that will be performing the proposed services, including the primary project manager.
 3. List the names of the subcontractors expected to be used, the services to be provided by the subcontractors and the amount of time that each is expected to spend on the project. Also, include the names and resumes of key subcontractor personnel who will be working on the assignment.
 4. Provide samples of relevant previous work products, especially sign designs and photographs of installed signs from past projects.
- C. Methodology and Approach to Scope of Work**
1. Describe any project approaches or ideas that you would apply to this project and that you feel would enhance the quality of the project and final product. Provide a specific timeline or schedule for the work. Show milestones and completion dates on the schedule.
 2. Describe the methods and timeline of communication your firm will use with the City's project manager, other involved City staff, and other interested parties.
- D. References:** A minimum of three (3) **references** with name, address, telephone number, and email address that can attest to your experience in projects of similar scope and size. The reference should also include the description of the project scope and lead staff assigned to the project.

- E. **Fee Proposal:** Provide a cost for the services and products broken down per task listed under the Scope of Work. The City is anticipating a budget ranging between \$50,000 to \$60,000 for this effort. Time and materials costs are not to exceed the amount of \$65,000. Provide a breakdown of all reimbursable expenses required to complete the work. If applicable, provide the subcontractor's costs as separate items. Provide hourly rate for your firm and all subcontractors. Provide total cost using Solicitation Response Form found in Section 6

- F. **Additional Data (optional):** Provide any additional information that will aid in evaluation of your qualifications with respect to this project.

SECTION 6.0: EVALUATION CRITERIA AND FACTORS

- 6.1 Evaluation:** An evaluation team shall review all responses and select the proposal or proposals that best demonstrate the capability in all aspects to perform the scope of services and possess the integrity and reliability that will ensure good faith performance.
- 6.2 Intent:** Only respondents who meet the qualification criteria will be considered. Therefore, it is imperative that the submitted proposal clearly indicate the firm's ability to provide the services described herein.

Submittal evaluations will be done in accordance with the criteria and procedure defined herein. The City reserves the right to reject any and all portions of proposals and take into consideration past performance, if available. The following parameters will be used to evaluate the submittals (in no particular order of priority). Definitions of each criterion is shown in parenthesis below each point.

- **Responsiveness of submittal to the RFP**
(Contractor has submitted a proposal that is fully comprehensive, inclusive, and conforms in all respects to the Request for Proposals (RFP) and all of its requirements, including all forms and substance.)
- **Understanding of the project and the objectives**
(Contractor's ability to demonstrate a thorough understanding of the City's goals pertaining to this specific project.)
- **Experience**
(Firm's proven proficiency in the successful completion of similar projects.)
- **Necessary Resources/Capability**
(Firm has provided sufficient information proving their available means to perform the required scope of work/service; to include appropriate bonding, insurance and all other requirements necessary to complete the project.)
- **Methodology & Implementation Plan**
(Firm has provided a clear interpretation of the City's objectives in regard to the project, and a fully comprehensive plan to achieve successful completion. See Section 5.0 Item C. – Strategy and Implementation Plan for details.)
- **References**
(Proof of performance in projects of similar scope and size from previous clients. See Section 5.0 Item E – References.)
- **Fees**
(All fees associated with the project are provided and are complete and comprehensive.)

City also reserves the right to take into consideration past performance of previous awards/contracts with the City of any vendor, contractor, supplier, or service provider in determining final award(s). The City will undertake negotiations with the top rated firm and will not negotiate with lower rated firms unless negotiations with higher rated firms have been unsuccessful and terminated.

- 6.3 Oral Interviews:** The City may invite the most qualified rated proposers to participate in oral interviews.
- 6.4 Award:** Firms shall be ranked or disqualified based on the criteria listed in Section 6.2. The City reserves the right to consider all of the information submitted and/or oral presentations, if required, in selecting the Consultant.

SECTION 7.0: SOLICITATION RESPONSE FORM
RFP-4825-20-SH Wayfinding Signage

Offeror must submit entire Form completed, dated and signed.

Please supply pricing broken into three (3) categories:

	Description of Service	Full Cost of Service
1	Design of all signs	\$
2	Materials for all signs	\$
3	Installation of all signs	\$
	Grand Total for Complete Project	\$

GRAND TOTAL WRITTEN: _____ dollars.

The City reserves the right to accept any portion of the work to be performed at its discretion

The undersigned has thoroughly examined the entire Request for Proposals and therefore submits the proposal and schedule of fees and services attached hereto.

This offer is firm and irrevocable for sixty (60) days after the time and date set for receipt of proposals.

The undersigned Offeror agrees to provide services and products in accordance with the terms and conditions contained in this Request for Proposal and as described in the Offeror's proposal attached hereto; as accepted by the City.

Prices in the proposal have not knowingly been disclosed with another provider and will not be prior to award.

- Prices in this proposal have been arrived at independently, without consultation, communication or agreement for the purpose of restricting competition.
- No attempt has been made nor will be to induce any other person or firm to submit a proposal for the purpose of restricting competition.
- The individual signing this proposal certifies they are a legal agent of the offeror, authorized to represent the offeror and is legally responsible for the offer with regard to supporting documentation and prices provided.
- Direct purchases by the City of Grand Junction are tax exempt from Colorado Sales or Use Tax. Tax exempt No. 98-903544. The undersigned certifies that no Federal, State, County or Municipal tax will be added to the above quoted prices.
- City of Grand Junction payment terms shall be Net 30 days.
- Prompt payment discount of _____ percent of the net dollar will be offered to the City if the invoice is paid within _____ days after the receipt of the invoice.

RECEIPT OF ADDENDA: the undersigned Contractor acknowledges receipt of Addenda to the Solicitation, Specifications, and other Contract Documents.

State number of Addenda received: _____.

It is the responsibility of the Proposer to ensure all Addenda have been received and acknowledged.

 Company Name – (Typed or Printed)

 Authorized Agent – (Typed or Printed)

 Authorized Agent Signature

 Phone Number

 Address of Offeror

 E-mail Address of Agent

 City, State, and Zip Code

 Date

EXHIBIT A

City of Grand Junction
 Department of Public Works
 Engineering Division

Project: Wayfinding
Subject: Cost Estimate

Include (1) / Not Include (0)		1	1	1	1	1	1	1
Priority	Quantities	Riverfront	Maroon	Purple	Gold	Green	Pink	Total
(Step)	Elements	City Limits	Airport to Downtown	Monument Rd/SouthC	Orchard Ave	26 Rd to Gunnison	Orchard Mesa Loop	
	Miles	25	6	10	8	7	6	62
1	Design	n/a	n/a	n/a	n/a	n/a	n/a	n/a
1	Endpoints	2	2	2	2	2	2	12
10	Large Info Boards	9	0	0	0	0	0	9
2	Route Turns							
2	- Posts	4	11	8	7	3	10	43
2	- Signs	16	44	32	28	12	40	172
3	Route Directional Mileage Signs							
3	- Posts	22	6	5	4	3	3	43
3	- Signs	53	12	10	8	7	6	96
4	Bridge Signs	8	0	0	0	0	0	8
4	Signalized Intersections	0	6	3	8	5	2	24
4	Roundabouts	0	3	1	0	0	0	4
5	Shared-Use Path Setions	25	2	6	3	0	1	37
5	Shared Sidewalk Sections	0	1	2	1	0	1	5
6	Street Crossing Markings	0	1	4	12	0	6	23
7	Sharrow Sections	0	2	2	0	2	6	12

Priority	Estimated Costs	\$/unit	Riverfront	Maroon	Purple	Gold	Green	Pink	Total	Cumulative
1	Endpoints	\$ 80	\$ 160	\$ 160	\$ 160	\$ 160	\$ 160	\$ 160	\$ 960	\$ 960
10	Large Info Boards	\$ 2,000	\$ -	\$ -	\$ -	\$ -	\$ -	\$ -	\$ -	\$ 960
2	Route Turns									\$ 960
2	- Posts	\$ 130	\$ 520	\$ 1,430	\$ 1,040	\$ 910	\$ 390	\$ 1,300	\$ 5,590	\$ 6,550
2	- Signs	\$ 45	\$ 720	\$ 1,980	\$ 1,440	\$ 1,260	\$ 540	\$ 1,800	\$ 7,740	\$ 14,290
3	Route Directional Mileage Signs									\$ 14,290
3	- Posts	\$ 130	\$ 2,860	\$ 780	\$ 650	\$ 520	\$ 390	\$ 390	\$ 5,590	\$ 19,880
3	- Signs	\$ 45	\$ 2,385	\$ 540	\$ 450	\$ 360	\$ 315	\$ 270	\$ 4,320	\$ 24,200
4	Bridge Signs	\$ 50	\$ 400	\$ -	\$ -	\$ -	\$ -	\$ -	\$ 400	\$ 24,600
4	Signalized Intersections	\$ 215	\$ -	\$ 1,290	\$ 645	\$ 1,720	\$ 1,075	\$ 430	\$ 5,160	\$ 29,760
4	Roundabouts	\$ 215	\$ -	\$ 645	\$ 215	\$ -	\$ -	\$ -	\$ 860	\$ 30,620
5	Shared-Use Path Setions	\$ 215	\$ 5,375	\$ 430	\$ 1,290	\$ 645	\$ -	\$ 215	\$ 7,955	\$ 38,575
5	Shared Sidewalk Sections	\$ 215	\$ -	\$ 215	\$ 430	\$ 215	\$ -	\$ 215	\$ 1,075	\$ 39,650
6	Street Crossing Markings	\$ 250	\$ -	\$ 250	\$ 1,000	\$ 3,000	\$ -	\$ 1,500	\$ 5,750	\$ 45,400
7	Sharrow Sections	\$ 350	\$ -	\$ 700	\$ 700	\$ -	\$ 700	\$ 2,100	\$ 4,200	\$ 49,600
	Total		\$ 12,420	\$ 8,420	\$ 8,020	\$ 8,790	\$ 3,570	\$ 8,380	\$ 49,600	

Design Total **\$ 15,000**

Sum total **\$ 64,600**

EXHIBIT B

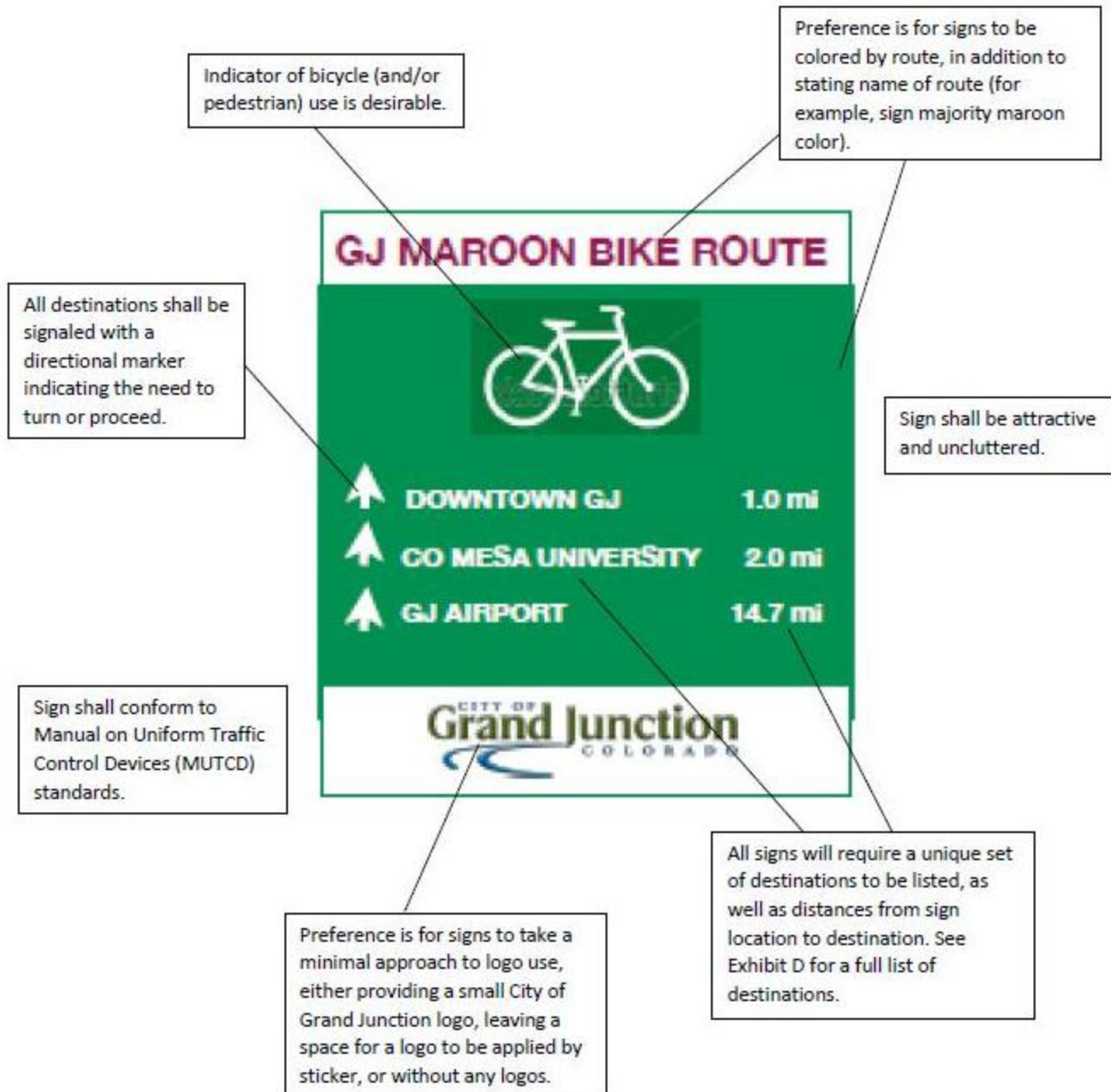

EXHIBIT C

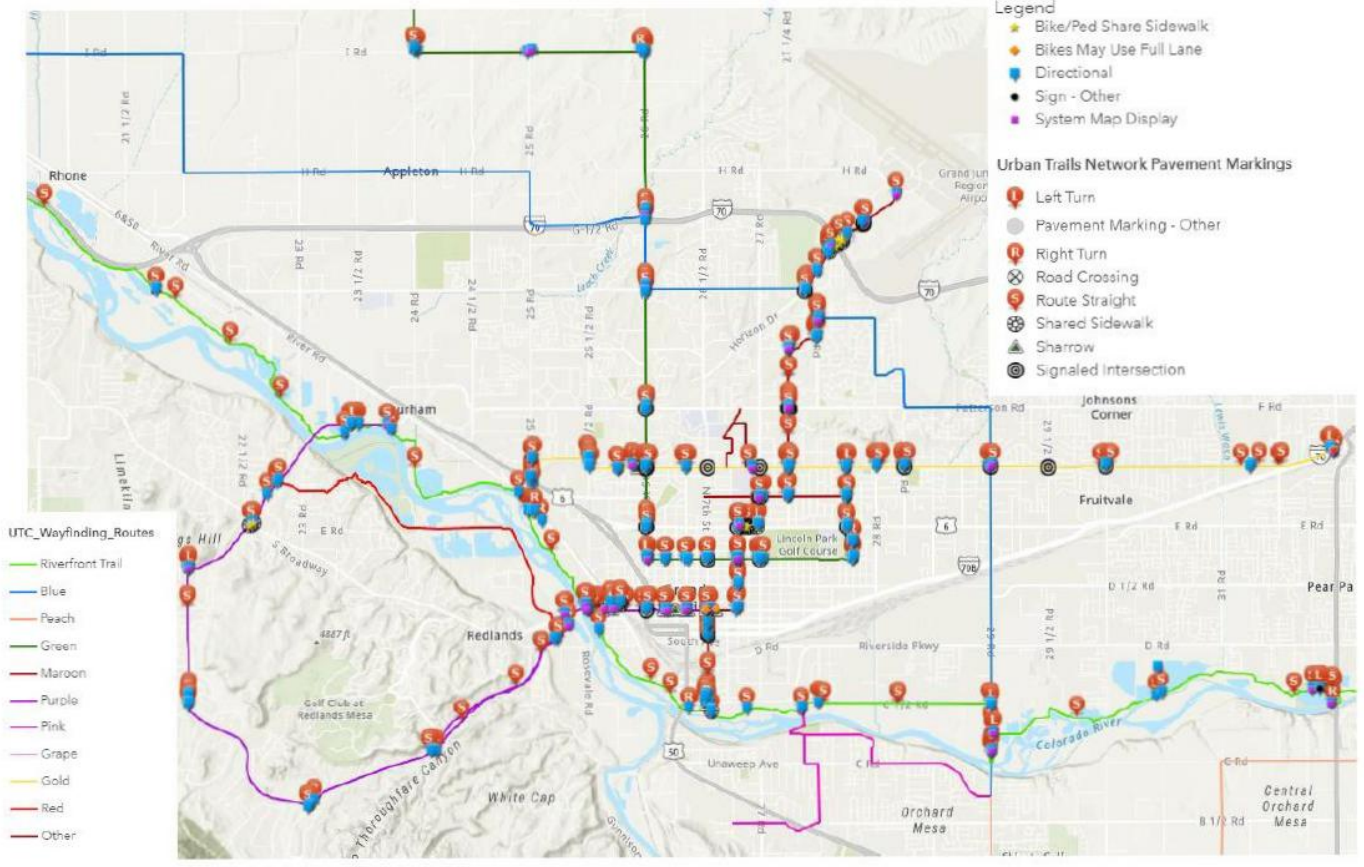

EXHIBIT D

The following list includes primary destinations for inclusion on wayfinding signage. These destinations are to be signaled on the routes indicated next to the destination.

DESTINATION	ROUTE(S)
Colorado Riverfront Trail Access	Maroon, Purple, Gold, Green, Pink
Horizon Drive Businesses	Purple, Gold
Colorado National Monument	Purple
Orchard Mesa	Pink, Riverfront
Colorado Mesa University	Gold, Green, Maroon, Riverfront
Corn Lake Colorado State Park	Riverfront
Redlands	Riverfront, Purple
Las Colonias Park	Riverfront, Pink, Purple, Maroon
Main Street	Riverfront, Maroon, Purple, Pink, Green
Redlands Parkway	Purple
Monument Road	Purple
Mesa Mall	Riverfront, Maroon, Purple, Gold
Lincoln Park	Maroon, Green, Gold
29 Road	Pink
Redlands Boat Launch	Riverfront
Eagle Rim Park	Pink
Dos Rios Elementary	Pink
Lunch Loops Bike Park	Purple, Riverfront
Airport	Maroon



Purchasing Division

ADDENDUM NO. 1

DATE: September 15, 2020
FROM: City of Grand Junction Purchasing Division
TO: All Interested Parties
RE: Wayfinding Signage RFP-4825-20-SH

Bidders responding to the above referenced solicitation are hereby instructed that the requirements have been clarified, modified, superseded and supplemented as to this date as hereinafter described.

Please make note of the following:

- 1. Question:** Is the winning bidder required to be a registered business or hold any type of licenses issued by the state of Colorado, the county of Mesa or the City of Grand Junction?
Answer: The City of Grand Junction Purchasing Division does not track necessary license requirements. We rely on contractors to be aware of the requirements for their respective professions.
- 2. Question:** As a starting point for the design for the wayfinding signage, what do you envision the size of these signs to be, how high out of the ground do you think they should be, and at what distance should the text be visible?
Answer: Since this is a three part question, the response shall be given in three parts:
a) Size: The sign blanks used in the past vary in size based on how many directions are needed on a sign. Previous sign blanks used are 36x9, 42x9, 24x30, and 24x36.
b). Height: sign height should be 7' from the ground to the bottom of sign.
c). Visibility/Distance: lettering is 3" and text is visible at 150'.
Attachment 1 (page 2 of this document) shows samples of signs currently in the field.

The original solicitation for the project referenced above is amended as noted.

All other conditions of subject remain the same.













Respectfully,

A handwritten signature in blue ink that reads "Susan J. Hyatt".

Susan Hyatt, Senior Buyer
City of Grand Junction, Colorado

Attachment 1

-  ORCHARD MESA →
- ↑  RIVERFRONT TRAIL E
- ←  ORCHARD MESA
- ↑  RIVERFRONT TRAIL W
- ←  RIVERFRONT TRAIL W
-  RIVERFRONT TRAIL E →
- ←  DOWNTOWN / 7th ST
-  DOWNTOWN / 7th ST →
- ↔  RIVERFRONT TRAIL
- ←  DOWNTOWN
- DOWNTOWN  →
- ←  ORCHARD MESA
- ↑  RIVERFRONT TRAIL W

							
↑ DOWNTOWN / 7 TH ST <small>1.0 MILES</small>	↑ LAS COLONIAS AMPHITHEATRE	← DOWNTOWN / GRAND AVE	REDLANDS →	↑ REDLANDS	← REDLANDS	↑ 24 ROAD / RIVERSIDE PKWY	↑ REDLANDS
↑ COLORADO MESA UNIVERSITY <small>2.0 MILES</small>	RIVER FRONT TRAIL →	REDLANDS →	DOWNTOWN / GRAND AVE →	← RIVERFRONT TRAIL WEST	RIVERFRONT TRAIL EAST →	RIVERFRONT TRAIL EAST →	← RIVERFRONT TRAIL EAST
							
↑ REDLANDS	↑ DOWNTOWN / MAIN ST	↑ 24 ROAD / RIVERSIDE PKWY	← REDLANDS				
↑ DOWNTOWN / GRAND AVE	← DOWNTOWN / GRAND AVE	↑ RIVERFRONT TRAIL EAST	← RIVERFRONT TRAIL WEST				
DOWNTOWN / MAIN ST →	← REDLANDS	RIVERFRONT TRAIL WEST →	24 ROAD / RIVERSIDE PKWY →				



**Request for Proposal
RFP-4825-20-SH**

WAYFINDING SIGNAGE

RESPONSES DUE:

September 23, 2020 prior to 2:30 P.M. Local Time

Accepting Electronic Responses Only
Responses Only Submitted Through the Rocky Mountain E-Purchasing
System (RMEPS)

www.bidnetdirect.com/colorado

(Purchasing Representative does not have access or control of the vendor side of RMEPS. If website or other problems arise during response submission, vendor **MUST** contact RMEPS to resolve issue prior to the response deadline. 800-835-4603)

PURCHASING REPRESENTATIVE:

Susan Hyatt
susanh@gjcity.org
970-244-1513

This solicitation has been developed specifically for a Request for Proposal intended to solicit competitive responses for this solicitation, and may not be the same as previous City of Grand Junction solicitations. All offerors are urged to thoroughly review this solicitation prior to submitting. Submittal by **FAX, EMAIL or HARD COPY IS NOT ACCEPTABLE** for this solicitation.

REQUEST FOR PROPOSAL

TABLE OF CONTENTS

Section

- 1.0 Administrative Information and Conditions for Submittal**
- 2.0 General Contract Terms and Conditions**
- 3.0 Insurance Requirements**
- 4.0 Specifications/Scope of Services**
- 5.0 Preparation and Submittal of Proposals**
- 6.0 Evaluation Criteria and Factors**
- 7.0 Solicitation Response Form**
- 8.0 Attachments**

REQUEST FOR PROPOSAL

SECTION 1.0: ADMINISTRATIVE INFORMATION & CONDITIONS FOR SUBMITTAL

- 1.1 Issuing Office:** This Request for Proposal (RFP) is issued by the City of Grand Junction (City). All contact regarding this RFP shall be directed to:

RFP Questions:

Susan Hyatt

susanh@gjcity.org

The City would like to remind all Contractors, Sub-Contractors, Vendors, Suppliers, Manufacturers, Service Providers, etc. that (with the exception of Pre-Bid or Site Visit Meetings) all questions, inquiries, comments, or communication pertaining to any formal solicitation (whether process, specifications, scope, etc.) must be directed (in writing) to the Purchasing Agent assigned to the project, or Purchasing Division. Direct communication with the City assigned Project Managers/Engineers is not appropriate for public procurement prior to award, and may result in disqualification.

- 1.2 Purpose:** The purpose of this RFP is to obtain proposals from qualified professional firms to provide and install Wayfinding Signage for the Grand Junction Public Works Department as described in Section 4.
- 1.3 Compliance:** All participating Offerors, by their signature hereunder, shall agree to comply with all conditions, requirements, and instructions of this RFP as stated or implied herein. Should the City omit anything from this packet which is necessary to the clear understanding of the requirements, or should it appear that various instructions are in conflict, the Offeror(s) shall secure instructions from the Purchasing Division prior to the date and time of the submittal deadline shown in this RFP.
- 1.4 Procurement Process:** Procurement processes shall be governed by the most current version of the City of Grand Junction [Purchasing Policy and Procedure Manual](#).
- 1.5 Submission:** Please refer to section 5.0 for what is to be included. **Each proposal shall be submitted in electronic format only, and only through the Rocky Mountain E-Purchasing website, www.bidnetdirect.com/colorado. The uploaded response shall be a single PDF document with all required information included. This site offers both "free" and "paying" registration options that allow for full access of the City's documents and for electronic submission of proposals.** (Note: "free" registration may take up to 24 hours to process. Please Plan accordingly.) For proper comparison and evaluation, the City requests that proposals be formatted as directed in Section 4.0 "Preparation and Submittal of Proposals." Submittals received that fail to follow this format may be ruled non-responsive. (Purchasing Representative does not have access or control of the vendor side of RMEPS. If website or other problems arise during response submission, vendor **MUST** contact RMEPS to resolve issue prior to the response deadline. **800-835-4603**)
- 1.6 Altering Proposals:** Any alterations made prior to opening date and time must be initialed by the signer of the proposal, guaranteeing authenticity. Proposals cannot be altered or amended after submission deadline.

- 1.7 Withdrawal of Proposal:** A proposal must be firm and valid for award and may not be withdrawn or canceled by the Offeror for sixty (60) days following the submittal deadline date, and only prior to award. The Offeror so agrees upon submittal of their proposal. After award this statement is not applicable.
- 1.8 Addenda:** All Questions shall be submitted in writing to the appropriate person as shown in Section 1.1. Any interpretations, corrections and changes to this RFP or extensions to the opening/receipt date shall be made by a written Addendum to the RFP by the City. Sole authority to authorize addenda shall be vested in the City of Grand Junction Purchasing Representative. Addenda will be issued electronically through the Rocky Mountain E-Purchasing website at www.bidnetdirect.com/colorado. Offerors shall acknowledge receipt of all addenda in their proposal. Addenda and solicitations are posted on the City's website, www.gjcity.org/business-and-economic-development/bids, for informational purposes.
- 1.9 Exception and Substitutions:** All proposals meeting the intent of this RFP shall be considered for award. Offerors taking exception to the specifications shall do so at their own risk. The Owner reserves the right to accept or reject any or all substitutions or alternatives. When offering substitutions and/or alternatives, Offeror must state these exceptions in the section pertaining to that area. Exception/substitution, if accepted, must meet or exceed the stated intent and/or specifications. The absence of such a list shall indicate that the Offeror has not taken exceptions, and if awarded a contract, shall hold the Offeror responsible to perform in strict accordance with the specifications or scope of work contained herein.
- 1.10 Confidential Material:** All materials submitted in response to this RFP shall ultimately become public record and shall be subject to inspection after contract award. "**Proprietary or Confidential Information**" is defined as any information that is not generally known to competitors and which provides a competitive advantage. Unrestricted disclosure of proprietary information places it in the public domain. Only submittal information clearly identified with the words "**Confidential Disclosure**" and uploaded as a separate document shall establish a confidential, proprietary relationship. Any material to be treated as confidential or proprietary in nature must include a justification for the request. The request shall be reviewed and either approved or denied by the City. If denied, the proposer shall have the opportunity to withdraw its entire proposal, or to remove the confidential or proprietary restrictions. Neither cost nor pricing information nor the total proposal shall be considered confidential or proprietary
- 1.11 Response Material Ownership:** All proposals become the property of the City upon receipt and shall only be returned to the proposer at the City's option. Selection or rejection of the proposal shall not affect this right. The City shall have the right to use all ideas or adaptations of the ideas contained in any proposal received in response to this RFP, subject to limitations outlined in the section titled "Confidential Material". Disqualification of a proposal does not eliminate this right.
- 1.12 Minimal Standards for Responsible Prospective Offerors:** A prospective Offeror must affirmably demonstrate their responsibility. A prospective Offeror must meet the following requirements:
- Have adequate financial resources, or the ability to obtain such resources as required.
 - Be able to comply with the required or proposed completion schedule.
 - Have a satisfactory record of performance.
 - Have a satisfactory record of integrity and ethics.

- Be otherwise qualified and eligible to receive an award and enter into a contract with the City.

- 1.13 Nonconforming Terms and Conditions:** A proposal that includes terms and conditions that do not conform to the terms and conditions of this Request for Proposal is subject to rejection as non-responsive. The City reserves the right to permit the Offeror to withdraw nonconforming terms and conditions from its proposal prior to a determination by the City of non-responsiveness based on the submission of nonconforming terms and conditions
- 1.14 Open Records:** All proposals shall be open for public inspection after the contract is awarded. Trade secrets and confidential information contained in the proposal so identified by offer as such shall be treated as confidential by the City to the extent allowable in the Open Records Act.
- 1.15 Sales Tax:** City of Grand Junction is, by statute, exempt from the State Sales Tax and Federal Excise Tax; therefore, all fees shall not include taxes.
- 1.16 Public Opening:** Proposals shall be opened in the City Hall Auditorium, 250 North 5th Street, Grand Junction, CO 81501, immediately following the proposal deadline. Offerors, their representatives and interested persons may be present. Only the names and locations on the proposing firms will be disclosed. **NOTE: Due to COVID-19 City Hall may be closed to the public. If so, following normal operating procedure the names and location of proposing firms will be posted on the City's website.**

SECTION 2.0: GENERAL CONTRACT TERMS AND CONDITIONS

- 2.1. Acceptance of RFP Terms:** A proposal submitted in response to this RFP shall constitute a binding offer. Acknowledgment of this condition shall be indicated on the Cover Letter by the Offeror or an officer of the Offeror legally authorized to execute contractual obligations. A submission in response to the RFP acknowledges acceptance by the Offeror of all terms and conditions, as set forth herein. An Offeror shall identify clearly and thoroughly any variations between its proposal and the City's RFP requirements. Failure to do so shall be deemed a waiver of any rights to subsequently modify the terms of performance, except as outlined or specified in the RFP.
- 2.2. Execution, Correlation, Intent, and Interpretations:** The Contract Documents shall be signed by the City and Contractor. By executing the contract, the Contractor represents that they have familiarized themselves with the local conditions under which the Work is to be performed, and correlated their observations with the requirements of the Contract Documents. The Contract Documents are complementary, and what is required by any one, shall be as binding as if required by all. The intention of the documents is to include all labor, materials, equipment, services and other items necessary for the proper execution and completion of the scope of work as defined in the technical specifications and drawings contained herein. All drawings, specifications and copies furnished by the City are, and shall remain, City property. They are not to be used on any other project.
- 2.3. Permits, Fees, & Notices:** The Contractor shall secure and pay for all permits, fees and licenses necessary for the proper execution and completion of the work. The Contractor shall give all notices and comply with all laws, ordinances, rules, regulations and orders of any public authority bearing on the performance of the work. If the Contractor observes that any of the Contract Documents are at variance in any respect, Contractor shall promptly

notify the Owner in writing, and any necessary changes shall be adjusted by change order/amendment. If the Contractor performs any work knowing it to be contrary to such laws, ordinances, rules and regulations, and without such notice to the Owner, Contractor shall assume full responsibility and shall bear all costs attributable.

- 2.4. **Responsibility for those Performing the Work:** The Contractor shall be responsible to the Owner for the acts and omissions of all their employees and all other persons performing any of the work under a contract with the Contractor.
- 2.5. **Use of the Site:** The Contractor shall confine operations at the site to areas permitted by law, ordinances, permits and the Contract Documents, and shall not unreasonably encumber the site with any materials or equipment.
- 2.6. **Cleanup:** The Contractor at all times shall keep the premises free from accumulation of waste materials or rubbish caused by their operations. At the completion of work they shall remove all their waste materials and rubbish from and about the project, as well as all their equipment and surplus materials.
- 2.7. **Payment & Completion:** The Contract Sum is stated in the Contract and is the total amount payable by the Owner to the Contractor for the performance of the work under the Contract Documents. Upon receipt of written notice that the work is ready for final inspection and acceptance and upon receipt of application for payment, the Owner's Project Manager will promptly make such inspection and, when Owner finds the work acceptable under the Contract Documents and the Contract fully performed, the Owner shall make payment in the manner provided in the Contract Documents. Partial payments will be based upon estimates, prepared by the Contractor, of the value of Work performed and materials placed in accordance with the Contract Documents.
- 2.8. **Performance & Payment Bonds:** Payment and Performance bonds are not required for this contract.
- 2.9. **Retention:** The Owner will deduct money from the partial payments in amounts considered necessary to protect the interest of the Owner and will retain this money until after completion of the entire contract. The amount to be retained from partial payments will be five (5) percent of the value of the completed work, and not greater than five (5) percent of the amount of the Contract. When the retainage has reached five (5) percent of the amount of the Contract no further retainage will be made and this amount will be retained until such time as final payment is made.
- 2.10. **Liquidated Damages for Failure to Meet Project Completion Schedule:** If the Contractor does not achieve Final Completion by the required date, whether by neglect, refusal or any other reason, the parties agree and stipulate that the Contractor shall pay liquidated damages to the City for each such day that final completion is late. As provided elsewhere, this provision does not apply for delays caused by the City. The date for Final Completion may be extended in writing by the Owner.

The Contractor agrees that as a part of the consideration for the City's awarding of this Contract liquidated damages in the daily amount of \$500.00 is reasonable and necessary to pay for the actual damages resulting from such delay. The parties agree that the real costs and injury to the City for such delay include hard to quantify items such as: additional engineering, inspection and oversight by the City and its agents; additional contract

administration; inability to apply the efforts of those employees to the other work of the City; perceived inefficiency of the City; citizens having to deal with the construction and the Work, rather than having the benefit of a completed Work, on time; inconvenience to the public; loss of reputation and community standing for the City during times when such things are very important and very difficult to maintain.

The Contractor must complete the Work and achieve final completion included under the Bid Schedule in the number of consecutive calendar days after the City gives its written Notice to Proceed. When the Contractor considers the entire Work ready for its intended use, Contractor shall certify in writing that the Work is substantially complete. In addition to the Work being substantially complete, Final Completion date is the date by which the Contractor shall have fully completed all clean-up, and all items that were identified by the City in the inspection for final completion. Unless otherwise stated in the Special Conditions, for purposes of this liquidated damages clause, the Work shall not be finished and the Contract time shall continue to accrue until the City gives its written Final Acceptance.

If the Contractor shall fail to pay said liquidated damages promptly upon demand thereof after having failed to achieve Final Completion on time, the City shall first look to any retainage or other funds from which to pay said liquidated damages; if retainage or other liquid funds are not available to pay said liquidated damages amounts, the Surety on the Contractor's Performance Bond and Payment Bond shall pay such liquidated damages. In addition, the City may withhold all, or any part of, such liquidated damages from any payment otherwise due the Contractor.

Liquidated damages as provided do not include any sums to reimburse the City for extra costs which the City may become obligated to pay on other contracts which were delayed or extended because of the Contractor's failure to complete the Work within the Contract Time. Should the City incur additional costs because of delays or extensions to other contracts resulting from the Contractor's failure of timely performance, the Contractor agrees to pay these costs that the City incurs because of the Contractor's delay, and these payments are separate from and in addition to any liquidated damages.

The Contractor agrees that the City may use its own forces or hire other parties to obtain Substantial or Final Completion of the work if the time of completion has elapsed and the Contractor is not diligently pursuing completion. In addition to the Liquidated Damages provided for, the Contractor agrees to reimburse the City for all expenses thus incurred.

- 2.11. Contingency/Force Account:** Contingency/Force Account work will be authorized by the Owner's Project Manager and is defined as minor expenses to cover miscellaneous or unforeseen expenses related to the project. The expenses are not included in the Drawings, Specifications, or Scope of Work and are necessary to accomplish the scope of this contract. Contingency/Force Account Authorization will be directed by the Owner through an approved form. Contingency/Force Account funds are the property of the Owner and any Contingency/Force Account funds, not required for project completion, shall remain the property of the Owner. Contractor is not entitled to any Contingency/Force Account funds, that are not authorized by Owner or Owner's Project Manager.
- 2.12. Protection of Persons & Property:** The Contractor shall comply with all applicable laws, ordinances, rules, regulations and orders of any public authority having jurisdiction for the safety of persons or property or to protect them from damage, injury or loss. Contractor shall erect and maintain, as required by existing safeguards for safety and protection, and all reasonable precautions, including posting danger signs or other warnings against

hazards promulgating safety regulations and notifying owners and users of adjacent utilities. When or where any direct or indirect damage or injury is done to public or private property by or on account of any act, omission, neglect, or misconduct by the Contractor in the execution of the work, or in consequence of the non-execution thereof by the Contractor, they shall restore, at their own expense, such property to a condition similar or equal to that existing before such damage or injury was done, by repairing, rebuilding, or otherwise restoring as may be directed, or it shall make good such damage or injury in an acceptable manner.

- 2.13. Changes in the Work:** The Owner, without invalidating the contract, may order changes in the work within the general scope of the contract consisting of additions, deletions or other revisions. All such changes in the work shall be authorized by Change Order and shall be executed under the applicable conditions of the contract documents. A Change Order is a written order to the Contractor signed by the Owner issued after the execution of the contract, authorizing a change in the work or an adjustment in the contract sum or the contract time.
- 2.14. Minor Changes in the Work:** The Owner shall have authority to order minor changes in the work not involving an adjustment in the contract sum or an extension of the contract time and not inconsistent with the intent of the contract documents.
- 2.15. Uncovering & Correction of Work:** The Contractor shall promptly correct all work found by the Owner as defective or as failing to conform to the contract documents. The Contractor shall bear all costs of correcting such rejected work, including the cost of the Owner's additional services thereby made necessary. The Owner shall give such notice promptly after discovering of condition. All such defective or non-conforming work under the above paragraphs shall be removed from the site where necessary and the work shall be corrected to comply with the contract documents without cost to the Owner.
- 2.16. Acceptance Not Waiver:** The City's acceptance or approval of any work furnished hereunder shall not in any way relieve the proposer of their present responsibility to maintain the high quality, integrity and timeliness of his work. The City's approval or acceptance of, or payment for, any services shall not be construed as a future waiver of any rights under this Contract, or of any cause of action arising out of performance under this Contract.
- 2.17. Change Order/Amendment:** No oral statement of any person shall modify or otherwise change, or affect the terms, conditions or specifications stated in the resulting contract. All change orders/amendments to the contract shall be made in writing by the Owner Purchasing Division.
- 2.18. Assignment:** The Offeror shall not sell, assign, transfer or convey any contract resulting from this RFP, in whole or in part, without the prior written approval from the City.
- 2.19. Compliance with Laws:** Proposals must comply with all Federal, State, County and local laws governing or covering this type of service and the fulfillment of all ADA (Americans with Disabilities Act) requirements. Contractor hereby warrants that it is qualified to assume the responsibilities and render the services described herein and has all requisite corporate authority and professional licenses in good standing, required by law.

- 2.20. Debarment/Suspension:** The Contractor hereby certifies that the Contractor is not presently debarred, suspended, proposed for debarment, declared ineligible, or voluntarily excluded from covered transactions by any Governmental department or agency.
- 2.21. Confidentiality:** All information disclosed by the City to the Contractor for the purpose of the work to be done or information that comes to the attention of the Contractor during the course of performing such work is to be kept strictly confidential.
- 2.22. Conflict of Interest:** No public official and/or City employee shall have interest in any contract resulting from this RFP.
- 2.23. Contract:** This Request for Proposal, submitted documents, and any negotiations, when properly accepted by the City, shall constitute a contract equally binding between the City and Offeror. The contract represents the entire and integrated agreement between the parties hereto and supersedes all prior negotiations, representations, or agreements, either written or oral, including the Proposal documents. The contract may be amended or modified with Change Orders, Field Orders, or Amendment.
- 2.24. Cancellation of Solicitation:** Any solicitation may be canceled by the City or any solicitation response by a vendor may be rejected in whole or in part when it is in the best interest of the City.
- 2.25. Project Manager/Administrator:** The Project Manager, on behalf of the Owner, shall render decisions in a timely manner pertaining to the work proposed or performed by the Offeror. The Project Manager shall be responsible for approval and/or acceptance of any related performance of the Scope of Work.
- 2.26. Contract Termination:** This contract shall remain in effect until any of the following occurs: (1) contract expires; (2) completion of services; (3) acceptance of services or, (4) for convenience terminated by either party with a written *Notice of Cancellation* stating therein the reasons for such cancellation and the effective date of cancellation at least thirty days past notification.
- 2.27. Employment Discrimination:** During the performance of any services per agreement with the City, the Offeror, by submitting a Proposal, agrees to the following conditions:
- 2.27.1.** The Offeror shall not discriminate against any employee or applicant for employment because of race, religion, color, sex, age, disability, citizenship status, marital status, veteran status, sexual orientation, national origin, or any legally protected status except when such condition is a legitimate occupational qualification reasonably necessary for the normal operations of the Offeror. The Offeror agrees to post in conspicuous places, visible to employees and applicants for employment, notices setting forth the provisions of this nondiscrimination clause.
- 2.27.2.** The Offeror, in all solicitations or advertisements for employees placed by or on behalf of the Offeror, shall state that such Offeror is an Equal Opportunity Employer.
- 2.27.3.** Notices, advertisements, and solicitations placed in accordance with federal law, rule, or regulation shall be deemed sufficient for the purpose of meeting the requirements of this section.

- 2.28. Immigration Reform and Control Act of 1986 and Immigration Compliance:** The Offeror certifies that it does not and will not during the performance of the contract employ illegal alien workers or otherwise violate the provisions of the Federal Immigration Reform and Control Act of 1986 and/or the immigration compliance requirements of State of Colorado C.R.S. § 8-17.5-101, *et seq.* (House Bill 06-1343).
- 2.29. Ethics:** The Offeror shall not accept or offer gifts or anything of value nor enter into any business arrangement with any employee, official, or agent of the City.
- 2.30. Failure to Deliver:** In the event of failure of the Offeror to deliver services in accordance with the contract terms and conditions, the City, after due oral or written notice, may procure the services from other sources and hold the Offeror responsible for any costs resulting in additional purchase and administrative services. This remedy shall be in addition to any other remedies that the City may have.
- 2.31. Failure to Enforce:** Failure by the Owner at any time to enforce the provisions of the contract shall not be construed as a waiver of any such provisions. Such failure to enforce shall not affect the validity of the contract or any part thereof or the right of the Owner to enforce any provision at any time in accordance with its terms.
- 2.32. Force Majeure:** The Offeror shall not be held responsible for failure to perform the duties and responsibilities imposed by the contract due to legal strikes, fires, riots, rebellions, and acts of God beyond the control of the Offeror, unless otherwise specified in the contract.
- 2.33. Indemnification:** Offeror shall defend, indemnify and save harmless the City and all its officers, employees, insurers, and self-insurance pool, from and against all liability, suits, actions, or other claims of any character, name and description brought for or on account of any injuries or damages received or sustained by any person, persons, or property on account of any negligent act or fault of the Offeror, or of any Offeror's agent, employee, subcontractor or supplier in the execution of, or performance under, any contract which may result from proposal award. Offeror shall pay any judgment with cost which may be obtained against the City growing out of such injury or damages.
- 2.34. Independent Firm:** The Offeror shall be legally considered an Independent Firm and neither the Firm nor its employees shall, under any circumstances, be considered servants or agents of the Owner. The Owner shall be at no time legally responsible for any negligence or other wrongdoing by the Firm, its servants, or agents. The Owner shall not withhold from the contract payments to the Firm any federal or state unemployment taxes, federal or state income taxes, Social Security Tax or any other amounts for benefits to the Firm. Further, the Owner shall not provide to the Firm any insurance coverage or other benefits, including Workers' Compensation, normally provided by the Owner for its employees.
- 2.35. Ownership:** All plans, prints, designs, concepts, etc., shall become the property of the Owner.
- 2.36. Oral Statements:** No oral statement of any person shall modify or otherwise affect the terms, conditions, or specifications stated in this document and/or resulting agreement. All modifications to this request and any agreement must be made in writing by the City.

- 2.37. Patents/Copyrights:** The Offeror agrees to protect the Owner from any claims involving infringements of patents and/or copyrights. In no event shall the Owner be liable to the Offeror for any/all suits arising on the grounds of patent(s)/copyright(s) infringement. Patent/copyright infringement shall null and void any agreement resulting from response to this RFP.
- 2.38. Remedies:** The Offeror and City agree that both parties have all rights, duties, and remedies available as stated in the Uniform Commercial Code.
- 2.39. Venue:** Any agreement as a result of this RFP shall be deemed to have been made in, and shall be construed and interpreted in accordance with, the laws of the City of Grand Junction, Mesa County, Colorado.
- 2.40. Expenses:** Expenses incurred in preparation, submission and presentation of this RFP are the responsibility of the company and cannot be charged to the City.
- 2.41. Sovereign Immunity:** The Owner specifically reserves its right to sovereign immunity pursuant to Colorado State Law as a defense to any action arising in conjunction to this agreement.
- 2.42. Public Funds/Non-Appropriation of Funds:** Funds for payment have been provided through the City's budget approved by the City Council/Board of County Commissioners for the stated fiscal year only. State of Colorado statutes prohibit the obligation and expenditure of public funds beyond the fiscal year for which a budget has been approved. Therefore, anticipated orders or other obligations that may arise past the end of the stated City's fiscal year shall be subject to budget approval. Any contract will be subject to and must contain a governmental non-appropriation of funds clause.
- 2.43. Collusion Clause:** Each Offeror by submitting a proposal certifies that it is not party to any collusive action or any action that may be in violation of the Sherman Antitrust Act. Any and all proposals shall be rejected if there is evidence or reason for believing that collusion exists among the proposers. The City may or may not, at the discretion of the City Purchasing Representative, accept future proposals for the same service or commodities for participants in such collusion.
- 2.44. Gratuities:** The Contractor certifies and agrees that no gratuities or kickbacks were paid in connection with this contract, nor were any fees, commissions, gifts or other considerations made contingent upon the award of this contract. If the Contractor breaches or violates this warranty, the City may, at their discretion, terminate this contract without liability to the City.
- 2.45. OSHA Standards:** All Offerors agree and warrant that services performed in response to this invitation shall conform to the standards declared by the US Department of Labor under the Occupational Safety and Health Act of 1970 (OSHA). In the event the services do not conform to OSHA Standards, the Owner may require the services to be redone at no additional expense to the Owner.
- 2.46. Performance of the Contract:** The City reserves the right to enforce the performance of the contract in any manner prescribed by law or deemed to be in the best interest of the City in the event of breach or default of resulting contract award.

- 2.47. Benefit Claims:** The Owner shall not provide to the Contractor any insurance coverage or other benefits, including Worker's Compensation, normally provided by the Owner for its employees.
- 2.48. Default:** The Owner reserves the right to terminate the contract immediately in the event the Contractor fails to meet delivery or completion schedules, or otherwise perform in accordance with the accepted proposal. Breach of contract or default authorizes the Owner to purchase like services elsewhere and charge the full increase in cost to the defaulting Contractor.
- 2.49. Multiple Offers:** Proposers must determine for themselves which product or service to offer. If said proposer chooses to submit more than one offer, THE ALTERNATE OFFER must be clearly marked "Alternate Proposal". The Owner reserves the right to make award in the best interest of the Owner.
- 2.50. Cooperative Purchasing:** Purchases as a result of this solicitation are primarily for the City. Other governmental entities may be extended the opportunity to utilize the resultant contract award with the agreement of the successful provider and the participating agencies. All participating entities will be required to abide by the specifications, terms, conditions and pricings established in this Proposal. The quantities furnished in this proposal document are for only the City. It does not include quantities for any other jurisdiction. The City will be responsible only for the award for our jurisdiction. Other participating entities will place their own awards on their respective Purchase Orders through their purchasing office or use their purchasing card for purchase/payment as authorized or agreed upon between the provider and the individual entity. The City accepts no liability for payment of orders placed by other participating jurisdictions that choose to piggy-back on our solicitation. Orders placed by participating jurisdictions under the terms of this solicitation will indicate their specific delivery and invoicing instructions.
- 2.51. Definitions:**
- 2.51.1.** "Offeror" and/or "Proposer" refers to the person or persons legally authorized by the Consultant to make an offer and/or submit a response (fee) proposal in response to the Owner's RFP.
- 2.51.2.** The term "Work" includes all labor, materials, equipment, and/or services necessary to produce the requirements of the Contract Documents.
- 2.51.3.** "Contractor" is the person, organization, firm or consultant identified as such in the Agreement and is referred to throughout the Contract Documents. The term Contractor means the Contractor or his authorized representative. The Contractor shall carefully study and compare the General Contract Conditions of the Contract, Specification and Drawings, Scope of Work, Addenda and Modifications and shall at once report to the Owner any error, inconsistency or omission he may discover. Contractor shall not be liable to the Owner for any damage resulting from such errors, inconsistencies or omissions. The Contractor shall not commence work without clarifying Drawings, Specifications, or Interpretations.
- 2.51.4.** "Sub-Contractor" is a person or organization who has a direct contract with the Contractor to perform any of the work at the site. The term sub-contractor is referred to throughout the contract documents and means a sub-contractor or his authorized representative.

2.52. Public Disclosure Record: If the Proposer has knowledge of their employee(s) or sub-proposers having an immediate family relationship with an City employee or elected official, the proposer must provide the Purchasing Representative with the name(s) of these individuals. These individuals are required to file an acceptable "Public Disclosure Record", a statement of financial interest, before conducting business with the City.

2.53. Keep Jobs in Colorado Act: Contractor shall be responsible for ensuring compliance with Article 17 of Title 8, Colorado Revised Statutes requiring 80% Colorado labor to be employed on public works projects. Contractor shall, upon reasonable notice provided by the Owner, permit the Owner to inspect documentation of identification and residency required by C.R.S. §8-17-101(2)(a). If Contractor claims it is entitled to a waiver pursuant to C.R.S. §8-17-101(1), Contractor shall state that there is insufficient Colorado labor to perform the work such that compliance with Article 17 would create an undue burden that would substantially prevent a project from proceeding to completion, and shall include evidence demonstrating the insufficiency and undue burden in its response.

Unless expressly granted a waiver by the Owner pursuant to C.R.S. §8-17-101(1), Contractor shall be responsible for ensuring compliance with Article 17 of Title 8, Colorado Revised Statutes requiring 80% Colorado labor to be employed on public works projects. Contractor shall, upon reasonable notice provided by the Owner, permit the Owner to inspect documentation of identification and residency required by C.R.S. §8-17-101(2)(a).

2.53.1. "Public Works project" is defined as:

- (a) any construction, alteration, repair, demolition, or improvement of any land, building, structure, facility, road, highway, bridge, or other public improvement suitable for and intended for use in the promotion of the public health, welfare, or safety and any maintenance programs for the upkeep of such projects
- (b) for which appropriate or expenditure of moneys may be reasonably expected to be \$500,000.00 or more in the aggregate for any fiscal year
- (c) except any project that receives federal moneys.

SECTION 3.0: INSURANCE REQUIREMENTS

Insurance Requirements: The selected Contractor agrees to procure and maintain, at its own cost, policy(s) of insurance sufficient to insure against all liability, claims, demands, and other obligations assumed by the Contractor pursuant to this Section. Such insurance shall be in addition to any other insurance requirements imposed by this Contract or by law. The Contractor shall not be relieved of any liability, claims, demands, or other obligations assumed pursuant to this Section by reason of its failure to procure or maintain insurance in sufficient amounts, durations, or types. Contractor shall procure and maintain and, if applicable, shall cause any Subcontractor of the Contractor to procure and maintain insurance coverage listed below. Such coverage shall be procured and maintained with forms and insurers acceptable to the Owner. In the case of any claims-made policy, the necessary retroactive dates and extended reporting periods shall be procured to maintain such continuous coverage. Minimum coverage limits shall be as indicated below unless specified otherwise:

(a) **Worker Compensation:** Contractor shall comply with all State of Colorado Regulations concerning Workers' Compensation insurance coverage.

(b) **General Liability insurance with minimum limits of:**

ONE MILLION DOLLARS (\$1,000,000) each occurrence and
ONE MILLION DOLLARS (\$1,000,000) per job aggregate.

The policy shall be applicable to all premises and operations. The policy shall include coverage for bodily injury, broad form property damage (including completed operations), personal injury (including coverage for contractual and employee acts), blanket contractual, products, and completed operations. The policy shall include coverage for explosion, collapse, and underground hazards. The policy shall contain a severability of interests provision.

(c) Comprehensive Automobile Liability insurance with minimum limits for bodily injury and property damage of not less than:

ONE MILLION DOLLARS (\$1,000,000) each occurrence and
ONE MILLION DOLLARS (\$1,000,000) aggregate

(d) Professional Liability & Errors and Omissions Insurance policy with a minimum of:

ONE MILLION DOLLARS (\$1,000,000) per claim

This policy shall provide coverage to protect the contractor against liability incurred as a result of the professional services performed as a result of responding to this Solicitation.

With respect to each of Contractors owned, hired, or non-owned vehicles assigned to be used in performance of the Work. The policy shall contain a severability of interests provision. The policies required by paragraph (b) above shall be endorsed to include the Owner, and the Owner's officers and employees as additional insureds. Every policy required above shall be primary insurance, and any insurance carried by the Owner, its officers, or its employees, or carried by or provided through any insurance pool of the Owner, shall be excess and not contributory insurance to that provided by Bidder. No additional insured endorsement to any required policy shall contain any exclusion for bodily injury or property damage arising from completed operations. The Bidder shall be solely responsible for any deductible losses under any policy required above.

SECTION 4.0: SPECIFICATIONS/SCOPE OF SERVICES

- 4.1 General:** The City of Grand Junction, Colorado (City) is seeking proposals from qualified Contractors for design and installation of bike/ped wayfinding signage on routes throughout the city.
- 4.2 Background**
- 4.2.1 Community Context:** The Grand Valley of Mesa County, Colorado is the largest population center between the Denver, Metropolitan Area (250 miles east) and the Salt Lake City Metropolitan Area (270 miles west). It serves as the economic and service center for communities in Western Colorado and Eastern Utah. The urbanized area of the Grand Valley is comprised of four major population centers: Clifton, Fruita, Grand Junction, and Palisade. Grand Junction and the Grand Valley have an increasingly robust multimodal transportation network, the centerpiece of which is the Colorado Riverfront Trail running almost continuously from Palisade through Grand Junction and past Fruita to the small town of Loma. The City of Grand Junction also maintains a network of on-street and off-street bike/ped facilities, many of which connect directly to the Riverfront Trail.
- 4.2.2 Project Context:** The City of Grand Junction, in cooperation with neighboring jurisdictions and local stakeholders, has been developing a proposal for wayfinding signage for over two years. Interest in a wayfinding program for the Grand Valley has persisted for more than two decades. In August of 2020, the City of Grand Junction was awarded a grant through the Colorado Department of Transportation (CDOT), called Revitalizing Main Streets, which has provided significant funding for this effort. Background materials relating to these preparatory efforts, particularly those produced by the City of Grand Junction Urban Trails Committee (UTC), establish many of the underlying needs and ideal product design elements for this project.
- 4.3 Project Overview**
- 4.3.1 Purpose:** The purpose of this project is to implement the first iteration of a comprehensive wayfinding system for Grand Junction, in cooperation with other Grand Valley jurisdictions. The aim is to finalize design for, and install, essential directional signage along six routes, including the Colorado Riverfront Trail.
- 4.3.2 Required Components:** The project requires finalization of a sign design, finalization of sign locations, and installation of signs and associated hardware. Sign design (**Exhibit B**) and sign locations (**Exhibit C**) have already been drafted by City of Grand Junction and volunteers associated with the City's Urban Trails Committee (UTC). The Contractor shall provide a minimum of three final design options for review and selection by the City of Grand Junction. The Contractor shall manufacture the signs and shall supply all crews, equipment, and materials for the production and installation of signs.
- 4.3.3 Area of Work:** All work shall take place within City of Grand Junction city limits. The Contractor may be required to cooperate with the City of Grand Junction to coordinate with other relevant authorities, including but not limited to Colorado Parks and Wildlife, Colorado Department of Transportation, Grand Junction Downtown Development Authority, One Riverfront Foundation, and Mesa County. The sign designs must be granted to the ownership of the City of Grand Junction for future use and for sharing with other Grand Valley jurisdictions to allow for unified design.

4.4 Specifications/Scope of Work: The awarded Contractor shall provide finalize design and locations of signs and shall install all sign hardware.

4.4.1 Minimum Specifications

The final scope of services will be the result of negotiations between the City and the selected Contractor as to how to best meet the City's goals for the planning process. The proposal should include, but is not limited to, recommendations for the following:

4.4.1.1 Design

- a. Present at least three draft design options of sufficient variety for selection by the City of Grand Junction
- b. Participate in up to two workshops for vetting of final sign designs with the City of Grand Junction and community stakeholders
- c. Develop design files based on final sign designs for each location, requiring unique directional information on all or most signs
- d. Produce signs that meet the following design specifications:
 - i. Indicate relevant destinations (**Exhibit D**) with direction and distance
 - ii. Indicate applicability to bicycles (and, if possible, pedestrians)
 - iii. Indicate, by color and language, the route with which each sign is associated
 - iv. Include, or allow for later inclusion, the City of Grand Junction logo
 - v. Conform to the Manual on Uniform Traffic Control Devices (MUTCD)
 - vi. Be attractive and uncluttered

4.4.1.2 Locations

- a. Evaluate and finalize the proposed locations of wayfinding signs

4.4.1.3 Production

- a. Print and manufacture all signs
- b. Provide posts and other hardware necessary for installation of signs

4.4.1.4 Installation

- a. Provide crews, equipment, and all other necessary supplies for installation of signs
- b. Install, in a timely manner, all signs as detailed in the attached spreadsheet (**Exhibit A**) at or near the locations identified in the attached map (**Exhibit C**)

4.4.1.5 Rights and Design Files

- a. Grant all rights sign designs and use thereof to the City of Grand Junction and,
- b. Provide all design and mapping files used in the finalization of sign designs and sign locations

4.4.2 Community Outreach: The Contractor shall participate in up to two (2) workshops with community stakeholders and the City of Grand Junction with the aim of finalizing sign designs and locations for installation.

4.4.3 City Staff: The Contractor shall communicate openly with City of Grand Junction staff throughout the project to attend to evolving demands within the project scope. The Contractor shall meet in person with City staff up to three (3) times to verify progress toward project outcomes and ensure alignment of work with permitting requirements and other needs associated with improvements to City infrastructure.

4.4.4 Other Specifications: The product shall be of a quality and durability that is suitable for long-term deployment within the City of Grand Junction. Materials shall be consistent with the needs and standards of a municipal infrastructure project. The Contractor shall provide Geographic Information Systems (GIS) based (or similar) map of sign locations to inform the finalized sign locations.

4.5 Owner's Responsibilities: City of Grand Junction staff will assist in providing information, maps, GIS data and other community-generated materials such as previous studies. Staff may also assist with developing a list of, coordinating meetings with, and distributing draft materials to relevant persons and agencies in the Grand Valley.

4.6 Proposal Content

4.6.1 Project Team: The proposal should respond directly to all elements of this Request. The proposal should include a cover letter as well as resumes for key employees of the Contractor and for any subcontractors. The proposal must also identify project personnel who will be responsible for and in charge of the work, as well as a review of current project workload and availability of project team members.

4.6.2 Team Qualifications: The proposal should also include information on the Contractor's unique qualifications and/or capabilities. Examples of similar projects including client contact information, project budget, completion date, and project team members are a required component of the proposal.

4.6.3 Timeline and Budget: The proposal should include the project timeline, including sub-timelines for major tasks proposed. A proposed budget or multiple budget scenarios that clearly correspond to the proposal narrative must be included in the proposal.

4.7 Minimum Mandatory Qualifications of Offeror: The Contractor's project manager(s) shall have at least 5 years of signage design experience and at least 5 years of signage installation experience. The Contractor's team shall include at least one (1) sign contractor licensed within the City of Grand Junction, and that individual shall be charged with supervision of signage installation. The ideal Contractor shall have participated in, or managed, a signage project with emphasis on bicycle/pedestrian wayfinding on a municipal, county, or regional scale.

4.8 Evaluation Criteria

4.8.1 Recommendation: Project staff from the City of Grand Junction Community Development Department and City Manager's Office will begin the evaluation process. Firms will be selected based upon their proposal's alignment with this Request and the qualifications presented by proposing Contractors. Selected firms will be interviewed by a committee composed of City staff. Contractors selected for interviews should be prepared to discuss, among other things, their approaches to implementing a wayfinding signage program, availability for the project, and experiences with similar projects.

4.8.2 Selection: Final selection of the Contractors will be made by a decision of the Director of the City of Grand Junction Department of Public Works.

4.9 RFP Tentative Time Schedule:

- Request for Proposal available on or about: August 31, 2020
- Inquiry deadline, no questions after this date: September 10, 2020
- Addendum posted: September 15, 2020
- Submittal deadline for proposals: September 23, 2020
- Final selection: September 25, 2020
- Contract execution: September 30, 2020
- Work begins: October 5, 2020
- Target Project Completion Date: November 30, 2020

4.10 Questions Regarding Scope of Services:

Susan Hyatt

susanh@gjcity.org

- 4.11 Contract:** The initial contract period shall be from October 1 through November 30, 2020 and may be renewed for a period up to 3 months, as mutually agreed by the City and the Consultant. All awards and extensions are subject to annual appropriation of funds.

SECTION 5.0: PREPARATION AND SUBMITTAL OF PROPOSALS

Submission: Each proposal shall be submitted in electronic format only, and only through the BidNet website, www.bidnetdirect.com/colorado. This site offers both “free” and “paying” registration options that allow for full access of the City’s documents and for electronic submission of proposals. (Note: “free” registration may take up to 24 hours to process. Please Plan accordingly.) (Purchasing Representative does not have access or control of the vendor side of RMEPS. If website or other problems arise during response submission, vendor **MUST** contact RMEPS to resolve issue prior to the response deadline; **800-835-4603**). For proper comparison and evaluation, the City requests that proposals be formatted as directed. The uploaded response to this RFP shall be a single PDF document with all required information included. Offerors are required to indicate their interest in this Project, show their specific experience and address their capability to perform the Scope of Services in the Time Schedule as set forth herein. For proper comparison and evaluation, the City requires that proposals be formatted **A to G**.

- A. Cover Letter:** Cover letter shall be provided which explains the Firm’s interest in the project. The letter shall contain the name/address/phone number/email of the person who will serve as the firm’s principal contact with City’s Contract Administrator and shall identify individual(s) who will be authorized to make presentations on behalf of the firm. The statement shall bear the signature of the person having proper authority to make formal commitments on behalf of the firm. By submitting a response to this solicitation the Contractor agrees to all requirements herein.
- B. Qualifications/Experience/Credentials:** Proposers shall provide their qualifications for consideration as a contract provider to the City of Grand Junction and include prior experience in similar projects, as follows:
1. Provide the name of the project manager for this assignment, including and overview of their experience as project manager for other similar assignments and amount of time this person is expected to spend on the project.
 2. Provide the names and resumes of key personnel that will be performing the proposed services, including the primary project manager.
 3. List the names of the subcontractors expected to be used, the services to be provided by the subcontractors and the amount of time that each is expected to spend on the project. Also, include the names and resumes of key subcontractor personnel who will be working on the assignment.
 4. Provide samples of relevant previous work products, especially sign designs and photographs of installed signs from past projects.
- C. Methodology and Approach to Scope of Work**
1. Describe any project approaches or ideas that you would apply to this project and that you feel would enhance the quality of the project and final product. Provide a specific timeline or schedule for the work. Show milestones and completion dates on the schedule.
 2. Describe the methods and timeline of communication your firm will use with the City’s project manager, other involved City staff, and other interested parties.
- D. References:** A minimum of three (3) **references** with name, address, telephone number, and email address that can attest to your experience in projects of similar scope and size. The reference should also include the description of the project scope and lead staff assigned to the project.

- E. Fee Proposal:** Provide a cost for the services and products broken down per task listed under the Scope of Work. The City is anticipating a budget ranging between \$50,000 to \$60,000 for this effort. Time and materials costs are not to exceed the amount of \$65,000. Provide a breakdown of all reimbursable expenses required to complete the work. If applicable, provide the subcontractor's costs as separate items. Provide hourly rate for your firm and all subcontractors. Provide total cost using Solicitation Response Form found in Section 6
- F. Additional Data (optional):** Provide any additional information that will aid in evaluation of your qualifications with respect to this project.

SECTION 6.0: EVALUATION CRITERIA AND FACTORS

- 6.1 Evaluation:** An evaluation team shall review all responses and select the proposal or proposals that best demonstrate the capability in all aspects to perform the scope of services and possess the integrity and reliability that will ensure good faith performance.
- 6.2 Intent:** Only respondents who meet the qualification criteria will be considered. Therefore, it is imperative that the submitted proposal clearly indicate the firm's ability to provide the services described herein.

Submittal evaluations will be done in accordance with the criteria and procedure defined herein. The City reserves the right to reject any and all portions of proposals and take into consideration past performance, if available. The following parameters will be used to evaluate the submittals (in no particular order of priority). Definitions of each criterion is shown in parenthesis below each point.

- **Responsiveness of submittal to the RFP**
(Contractor has submitted a proposal that is fully comprehensive, inclusive, and conforms in all respects to the Request for Proposals (RFP) and all of its requirements, including all forms and substance.)
- **Understanding of the project and the objectives**
(Contractor's ability to demonstrate a thorough understanding of the City's goals pertaining to this specific project.)
- **Experience**
(Firm's proven proficiency in the successful completion of similar projects.)
- **Necessary Resources/Capability**
(Firm has provided sufficient information proving their available means to perform the required scope of work/service; to include appropriate bonding, insurance and all other requirements necessary to complete the project.)
- **Methodology & Implementation Plan**
(Firm has provided a clear interpretation of the City's objectives in regard to the project, and a fully comprehensive plan to achieve successful completion. See Section 5.0 Item C. – Strategy and Implementation Plan for details.)
- **References**
(Proof of performance in projects of similar scope and size from previous clients. See Section 5.0 Item E – References.)
- **Fees**
(All fees associated with the project are provided and are complete and comprehensive.)

City also reserves the right to take into consideration past performance of previous awards/contracts with the City of any vendor, contractor, supplier, or service provider in determining final award(s). The City will undertake negotiations with the top rated firm and will not negotiate with lower rated firms unless negotiations with higher rated firms have been unsuccessful and terminated.

- 6.3 Oral Interviews:** The City may invite the most qualified rated proposers to participate in oral interviews.
- 6.4 Award:** Firms shall be ranked or disqualified based on the criteria listed in Section 6.2. The City reserves the right to consider all of the information submitted and/or oral presentations, if required, in selecting the Consultant.

SECTION 7.0: SOLICITATION RESPONSE FORM
RFP-4825-20-SH Wayfinding Signage

Offeror must submit entire Form completed, dated and signed.

Please supply pricing broken into three (3) categories:

	Description of Service	Full Cost of Service
1	Design of all signs	\$ 7,500.00
2	Materials for all signs	\$ 45,030.00
3	Installation of all signs	\$ 41,845.00
	Grand Total for Complete Project	\$ 94,375.00

GRAND TOTAL WRITTEN: Ninety Four Thousand Three Hundred Seventy Five and 00/100 dollars.

The City reserves the right to accept any portion of the work to be performed at its discretion

The undersigned has thoroughly examined the entire Request for Proposals and therefore submits the proposal and schedule of fees and services attached hereto.

This offer is firm and irrevocable for sixty (60) days after the time and date set for receipt of proposals.

The undersigned Offeror agrees to provide services and products in accordance with the terms and conditions contained in this Request for Proposal and as described in the Offeror's proposal attached hereto; as accepted by the City.

Prices in the proposal have not knowingly been disclosed with another provider and will not be prior to award.

- Prices in this proposal have been arrived at independently, without consultation, communication or agreement for the purpose of restricting competition.
- No attempt has been made nor will be to induce any other person or firm to submit a proposal for the purpose of restricting competition.
- The individual signing this proposal certifies they are a legal agent of the offeror, authorized to represent the offeror and is legally responsible for the offer with regard to supporting documentation and prices provided.
- Direct purchases by the City of Grand Junction are tax exempt from Colorado Sales or Use Tax. Tax exempt No. 98-903544. The undersigned certifies that no Federal, State, County or Municipal tax will be added to the above quoted prices.
- City of Grand Junction payment terms shall be Net 30 days.
- Prompt payment discount of 0 percent of the net dollar will be offered to the City if the invoice is paid within na days after the receipt of the invoice.

RECEIPT OF ADDENDA: the undersigned Contractor acknowledges receipt of Addenda to the Solicitation, Specifications, and other Contract Documents.

State number of Addenda received: 1.

It is the responsibility of the Proposer to ensure all Addenda have been received and acknowledged.

Bud's Signs

 Company Name – (Typed or Printed)

Paul Schritter

 Authorized Agent – (Typed or Printed)

Authorized Agent Signature

Phone Number

Paul Schritter Digitally signed by Paul Schritter
 Date: 2020.09.23 09:48:51 -06'00'

970-245-7700

Address of Offeror

E-mail Address of Agent

1040 Pitkin Grand Junction CO 81501

09-23-2020

City, State, and Zip Code

Date

EXHIBIT A

City of Grand Junction
 Department of Public Works
 Engineering Division

Project: Wayfinding
Subject: Cost Estimate

Include (1) / Not Include (0)		1	1	1	1	1	1	1
Priority	Quantities	Riverfront	Maroon	Purple	Gold	Green	Pink	Total
(Step)	Elements	City Limits	Airport to Downtown	Monument Rd/South	Orchard Ave	26 Rd to Gunnison	Orchard Mesa Loop	
	Miles	25	6	10	8	7	6	62
1	Design	n/a	n/a	n/a	n/a	n/a	n/a	n/a
1	Endpoints	2	2	2	2	2	2	12
10	Large Info Boards	9	0	0	0	0	0	9
2	Route Turns							
2	- Posts	4	11	8	7	3	10	43
2	- Signs	16	44	32	28	12	40	172
3	Route Directional Mileage Signs							
3	- Posts	22	6	5	4	3	3	43
3	- Signs	53	12	10	8	7	6	96
4	Bridge Signs	8	0	0	0	0	0	8
4	Signalized Intersections	0	6	3	8	5	2	24
4	Roundabouts	0	3	1	0	0	0	4
5	Shared-Use Path Sections	25	2	6	3	0	1	37
5	Shared Sidewalk Sections	0	1	2	1	0	1	5
6	Street Crossing Markings	0	1	4	12	0	6	23
7	Sharrow Sections	0	2	2	0	2	6	12

Priority	Estimated Costs	\$/unit	Riverfront	Maroon	Purple	Gold	Green	Pink	Total	Cumulative
1	Endpoints	\$ 80	\$ 160	\$ 160	\$ 160	\$ 160	\$ 160	\$ 160	\$ 960	\$ 960
10	Large Info Boards	\$ 2,000	\$ -	\$ -	\$ -	\$ -	\$ -	\$ -	\$ -	\$ 960
2	Route Turns									\$ 960
2	- Posts	\$ 130	\$ 520	\$ 1,430	\$ 1,040	\$ 910	\$ 390	\$ 1,300	\$ 5,590	\$ 6,550
2	- Signs	\$ 45	\$ 720	\$ 1,980	\$ 1,440	\$ 1,260	\$ 540	\$ 1,800	\$ 7,740	\$ 14,290
3	Route Directional Mileage Signs									\$ 14,290
3	- Posts	\$ 130	\$ 2,860	\$ 780	\$ 650	\$ 520	\$ 390	\$ 390	\$ 5,590	\$ 19,880
3	- Signs	\$ 45	\$ 2,385	\$ 540	\$ 450	\$ 360	\$ 315	\$ 270	\$ 4,320	\$ 24,200
4	Bridge Signs	\$ 50	\$ 400	\$ -	\$ -	\$ -	\$ -	\$ -	\$ 400	\$ 24,600
4	Signalized Intersections	\$ 215	\$ -	\$ 1,290	\$ 645	\$ 1,720	\$ 1,075	\$ 430	\$ 5,160	\$ 29,760
4	Roundabouts	\$ 215	\$ -	\$ 645	\$ 215	\$ -	\$ -	\$ -	\$ 860	\$ 30,620
5	Shared-Use Path Sections	\$ 215	\$ 5,375	\$ 430	\$ 1,290	\$ 645	\$ -	\$ 215	\$ 7,955	\$ 38,575
5	Shared Sidewalk Sections	\$ 215	\$ -	\$ 215	\$ 430	\$ 215	\$ -	\$ 215	\$ 1,075	\$ 39,650
6	Street Crossing Markings	\$ 250	\$ -	\$ 250	\$ 1,000	\$ 3,000	\$ -	\$ 1,500	\$ 5,750	\$ 45,400
7	Sharrow Sections	\$ 350	\$ -	\$ 700	\$ 700	\$ -	\$ 700	\$ 2,100	\$ 4,200	\$ 49,600
	Total		\$ 12,420	\$ 8,420	\$ 8,020	\$ 8,790	\$ 3,570	\$ 8,380	\$ 49,600	

Design

Total \$ 15,000

Sum total \$ 64,600

EXHIBIT B

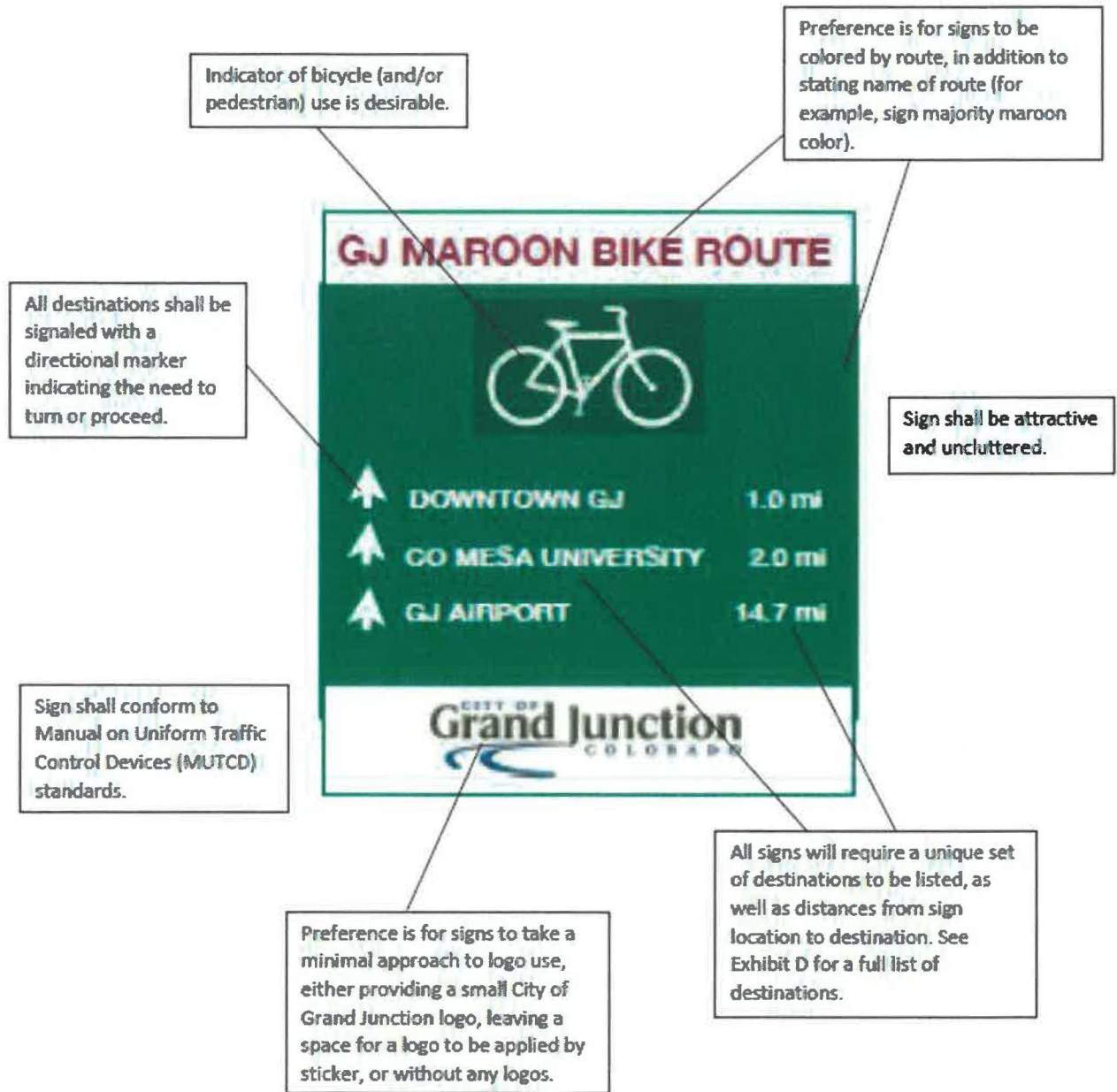

EXHIBIT C

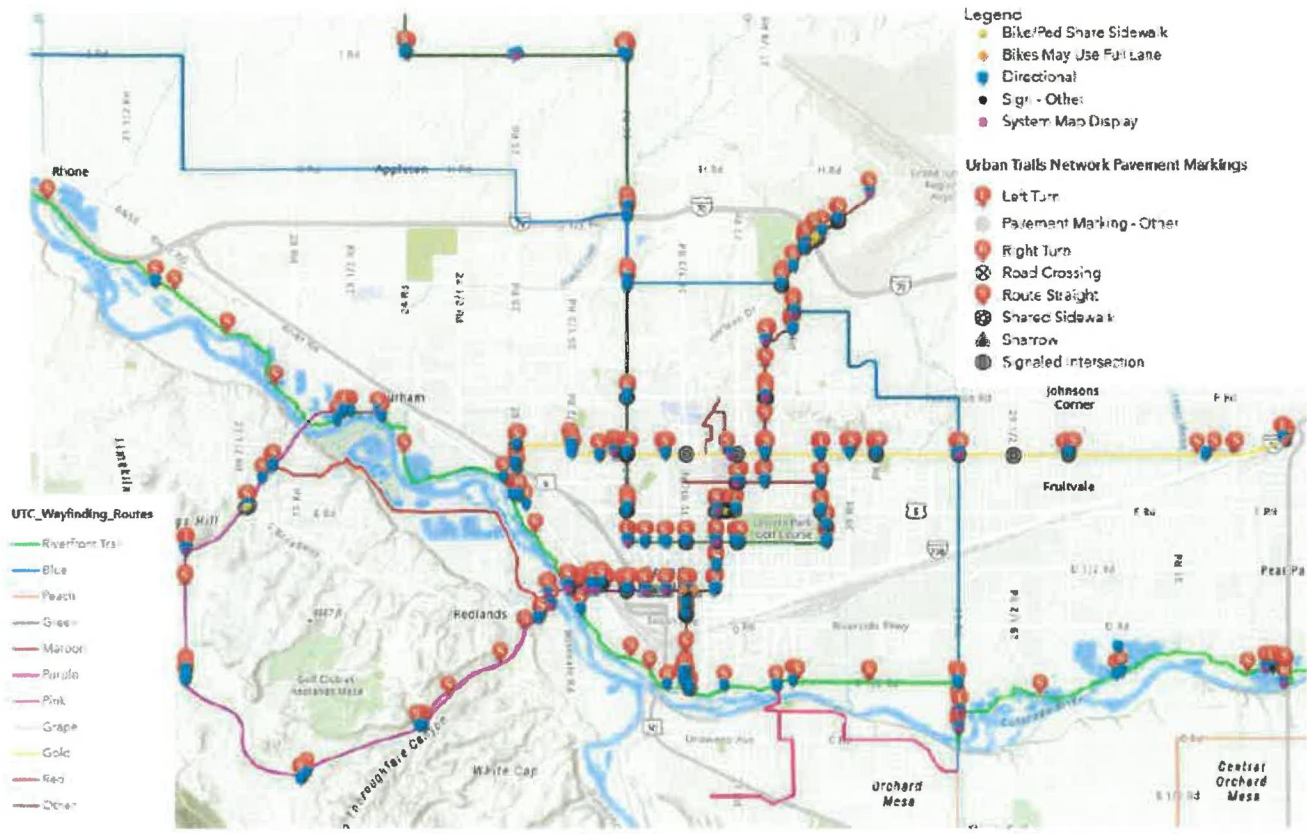

EXHIBIT D

The following list includes primary destinations for inclusion on wayfinding signage. These destinations are to be signaled on the routes indicated next to the destination.

DESTINATION	ROUTE(S)
Colorado Riverfront Trail Access	Maroon, Purple, Gold, Green, Pink
Horizon Drive Businesses	Purple, Gold
Colorado National Monument	Purple
Orchard Mesa	Pink, Riverfront
Colorado Mesa University	Gold, Green, Maroon, Riverfront
Corn Lake Colorado State Park	Riverfront
Redlands	Riverfront, Purple
Las Colonias Park	Riverfront, Pink, Purple, Maroon
Main Street	Riverfront, Maroon, Purple, Pink, Green
Redlands Parkway	Purple
Monument Road	Purple
Mesa Mall	Riverfront, Maroon, Purple, Gold
Lincoln Park	Maroon, Green, Gold
29 Road	Pink
Redlands Boat Launch	Riverfront
Eagle Rim Park	Pink
Dos Rios Elementary	Pink
Lunch Loops Bike Park	Purple, Riverfront
Airport	Maroon

Experience Documentation of Bud's Signs and of Bud Preuss

Bud's Signs has been a premier sign contractor in the Grand Valley since July 1980 specializing in custom sign design and installation. Bud's Signs has been involved in all aspects of the sign business from concept development, design, fabrication, repairs, and installation for this entire 40 years.

Bud's is a current contractor license holder, good standing, with multiple municipalities within the State of Colorado and all neighboring states. Bud's has proven experience in administration and supervision of very large projects in Grand Junction, Phoenix, Denver, Colorado Springs, etc. A detailed list is available upon request.

Mr. Preuss has been the owner of the company since its inception and continues in the daily operations of the business. His oversight is seen in all aspects of the business and is the lead designer for this project

Experience Documentation of Paul Schritter

Paul Schritter's critical experience began in 1976 working with Taylor Fence Co as an installer and migrated his way through positions of foreman, crew supervisor and ending in 1984 with the Assistant Manager position. Paul then started his own sales based business that was run successfully for 26 years. Following a trial period of retirement, Paul started working for Bud's Signs and progressed to Installation Manager. Paul is well versed in management of people, equipment, and job administration.

Timeline and Budget Narrative (section 4.6.3)

We will be partnering with KSK, LLC throughout this project. We, Bud's Signs, will provide all design work as called for in sections 4.XX of the project documents and all of the materials needed to complete the project. KSK, LLC will be providing all of the installation labor and equipment. All of their letters of qualifications, experience and planned process are attached to this narrative section.

We will provide the proposed drawings as requested, facilitate the workshops required for the vetting process, and finish all final drawing for approval in the weeks following award of Contract. Samples will be fabricated for presentation upon request. Prior to fabrication we will ask for, as we do with all larger cost projects, a down payment/deposit of 50% of the contact value. This is to assist in the procurement of materials needed and labor already expensed for the project. Following the receipt of the deposit and approval of the samples, we will begin with gathering of the materials needed. Once a sufficient quantity of the posts and raw sign material arrive, we will begin installing posts and cutting out of the sign faces. We project that it will take approximately 45 days to have all posts in place, ready to receive the signs. During this 45 day time frame the fabrication and print processes should be completed and the sign face installation could begin. We project that the entire project should be complete within 60 days from our starting date, depending upon weather.

Experience Letter of Kirk Knowles and KSK, LLC

I have over 25 years of experience in the traffic control and highway sign installation industry. Over 320 CDOT projects and 155 County and Municipality projects.

Since 2017, I have developed KSK, LLC into a Prime Contractor Project Management Company. KSK has been the Prime Contractor on several CDOT and Municipality projects.

- I-70B&Z GJ Phase 1 ADA Ramps; NHPP 070A-032 (22484)
- Rangely Pedestrian Improvements; MTCE 0641-103 (22411)
- Craig Residency, Region 3 ADA Ramps; CR 300-248 (22768)
- City of Craig Sidewalk Improvements; SHE M255-006 (22214)
- I-70 Exit 26 Ramp Improvements; SHE 0701-243 (22318)
- Town of Crawford Concrete Rehabilitation Project (2019)
- GJ Phase 1 ADA Ramps; C C080-037 (23266)
- Region 3 ADA Ramps 2020; STR R300-249 (22805)
- Highway 340 Shoulder Widening; STA 340A-021 (21936)
- Pitkin County, Dynamic Highway Message Sign Project; 004.20

On these Prime Contractor projects, KSK has self-performed Traffic Control, Erosion Control, Project Management, Project Scheduling, Subcontractor Scheduling, Permanent Sign Installation, Health and Safety Management, Material Management, HAZMAT Monitoring and landscaping.

In my 25 years of experience and almost 500 highway construction projects, I performed one or more of the following Traffic Control functions:

Management of Traffic (MOT) development/design; Schedule equipment quantity development; Method of Handling Traffic (MHT) development; MHT execution; Traffic Control Plan (TCP) development; TCP execution; Development of 24-hour operations; Traffic control progress scheduling; Schedule and equipment planning; Traffic Control Management; Traffic Control Supervisor (ATSSA Certified); and Personnel scheduling.

MHT development and execution has included shoulder operations; one lane road operations, flagging operations; lane closure and multi-lane closure operations; road closures, intersection operations (4-way and 3-way), Stop/Yield operations; mobile operations; interstate head-to-head and crossover operations; pilot car operations, one lane traffic signal operations (24 hour), T-intersection traffic signal operations (shift and 24 hour).

On these projects, I performed one or more of the following Permanent Signing functions:

Sign design; Sign layout; Project layout; Project pattern; Product selection; Turn-key installation.

I have been involved in the design, development and installation of sign support structures to include:

Sign Bridges, Sign Cantilevers, Sign Butterflies, Caissons, Concrete footings, Slip Base, PoziLoc, Square Tube (temporary and permanent), Transpo Base, 4X4 timber post, 6X6 timber post and U-Channel. Surface, barrier and ground mount.

I have worked on new bridge structure projects and bridge rehabilitation projects in every CDOT Region except for Region 2. The number of projects are too numerous to list. Over the past ten years, I have been involved with the development and construction of over 60 CDOT structure projects. Dealing with Traffic Control and/or Permanent Signing functions.

I have bid, managed and supervised CDOT prime contractor contracts in every CDOT Region since 1998.

Over the past 25 years, I have been involved in the design, planning and/or development of the following CMGC projects:

Dotsero Roundabout - Kraemer NA*

I-70 Central Park - Sema*

Highway 6 Garrison - Hamon Constructors*

I-25 and Highway 6 - Hamon Constructors

I-25 and 120th North - Hamon Constructors

Twin Tunnels (Phase I and II) - Kraemer NA*

PPSL (Phase I, II and III) - Mountain Corridor Constructors*

Highway 82 Grand Avenue Bridge - Granite/Wadsworth*

Hanging Lake Tunnels - Meyers and Sons*

Town of Vail, I-70 Frontage Road Underpass - Kraemer NA*

*Received construction contract following design

KSK, LLC
P.O. Box 4768
Grand Junction, Colorado 81502
(970) 260-3377

References:

Martinez Western
Paul Martinez
970-989-5358
335 Village Drive
Rifle, CO 81560

TS&L, LLC
Chad Harris
Grand Junction, CO
970-210-0439

Damian Leyba
CDOT Region 3
Grand Junction Residency
Project Engineer
970-309-4577

Town of Crawford
Cally Gallegos
425 Hwy 92
Crawford CO 81415
970-921-4725

Mark Construction
Tad Hatter
Grand Junction, CO
970-261-9406

SAW PR
Sherry Wright
Grand Junction, CO
970-270-3845

**KSK LLC
PO Box 4768
Grand Junction, CO 81502**

Date: September 21, 2020
Project Number: RFP-4825-20-SH
Project Name: City of Grand Junction, Wayfinding Signage

Method Statement – Base, Post and Sign Installation

Base and Socket Installation

Procedures: Excavation is pre-marked and utility locates are performed. Next, the hole will be drilled to the desired dimensions and loose dirt is removed from the hole. Concrete will be mixed on site or delivered by mixing truck. The base/socket will then be inserted into the hole and leveled.

Production Rates: Vary based on auging conditions (dirt, sand, rock, etc.) and weather conditions. Production average is six to ten bases per day

Labor Force: Three-man crew.

Equipment: The equipment that will be used includes a wheel barrel and hand tools for digging holes and pouring concrete. We will use a skid-loader with auger attachment, where access is available. Two trucks and trailers.

Work time: We will be working normal day light work hours on a five day week.

Post and Sign Installation

Procedures: Sign is properly mounted to the post using new hardware (old hardware from resets will not be used). Post is mounted onto the base (SlipBase) or into the socket with wedge (PoziLo), and then properly leveled. NOTE: sign panel resets will be reset with the existing post in place.

Production Rates: Vary based on terrain conditions and weather conditions. Production average is thirty to forty signs/posts per day.

Labor Force: Three-man crew.

Equipment: The equipment that will be used includes a ladder, post level and hand tool. Two trucks and trailers.

Work time: We will be working normal day light work hours on a five day week.

KSK, LLC
P.O. Box 4768
Grand Junction, Colorado 81502
(970) 260-3377

September 21, 2020

To: Bud Signs
From: KSK, LLC
RE: Quote
City of Grand Junction, Wayfinding Signage
RFP-4825-20-SH

Installation of All Signs = \$52,500.00 (Pricing is for PoziLoc post/socket/wedge system AND/OR U-3 Green Channel post system)

Pricing includes:

1. Assistance in identifying sign locations
2. Utility locates
3. Full sign installation (per CDOT, MUTCD and manufacturer specification)
 - a. Base installation
 - b. Post installation
 - c. Sign and hardware installation
4. Full costs of all posts, sign mounting hardware and concrete
5. Site clean up
6. Full Traffic Control (per MUTCD)
 - a. MHT generation
 - b. Traffic Control Supervisor (Certified)
 - c. Flaggers
 - d. All required signing and channelizing devices
7. Full Mobilization costs

Pricing does not include:

1. Sign material
2. Sign production

Please contact me with any questions or clarifications.

Thank you for your time and consideration.

Kirk Knowles

Kirk Knowles
Managing Member

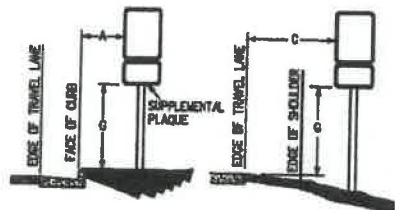
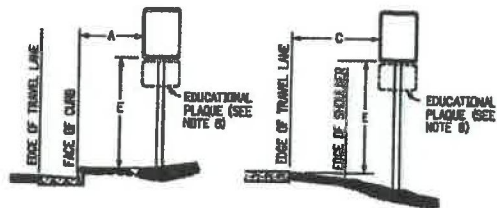

REGULATORY, RECREATIONAL AND CULTURAL INFORMATION SIGN PLACEMENT

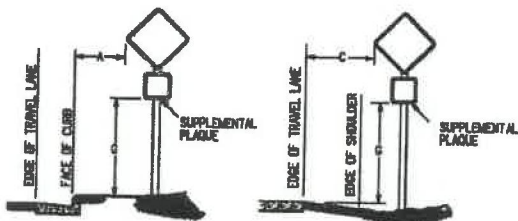

WARNING SIGN PLACEMENT

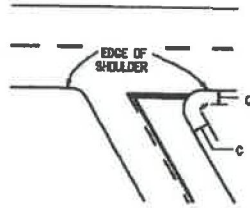

ACUTE ANGLE INTERSECTION

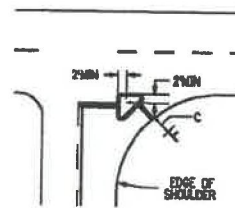

CHANNELIZED INTERSECTION

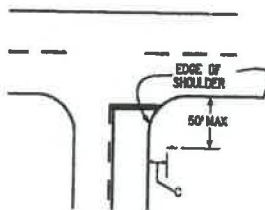

WIDE-THROAT INTERSECTION

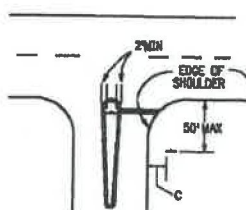

DIVISIONAL ISLAND

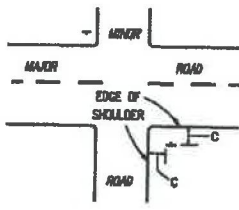

MINOR CROSSROAD

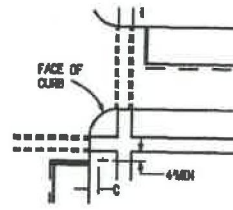

URBAN INTERSECTION

TYPICAL LOCATIONS—STOP SIGNS AND YIELD SIGNS

GENERAL NOTES

1. THE ENGINEER WILL ESTABLISH GRADES AND LOCATIONS FOR ALL SIGN POSTS IN ACCORDANCE WITH DETAILS SHOWN ON THE PLANS.
2. SPECIAL CARE SHALL BE TAKEN IN SIGN LOCATION TO ENSURE AN UNOBSTRUCTED VIEW OF EACH SIGN.
3. MINIMUM POST EMBEDMENT SHALL BE 3 FT. FOR 4-8 POSTS AND 4-IN X 4-IN TIMBER POSTS, AND 5 FT FOR 6-IN X 8-IN TIMBER POSTS. SEE APPLICABLE STANDARDS FOR FOOTING DEPTH.
4. IF A SHOULDER IS WIDER THAN 6 FT., THE MINIMUM LATERAL OFFSET DISTANCE SHOULD BE 6 FT. FROM THE EDGE OF SHOULDER, EXCEPT FOR MILE MARKER SIGNS. SEE FIGURE 24-209 OF THE 2009 MUTCD.
5. NORMAL LATERAL PLACEMENT IS MEASURED FROM THE EDGE OF THE TRAVEL LANE.
6. IN URBAN AREAS, A LATERAL CLEARANCE OF 1 FT FROM THE CURB FACE IS PERMISSIBLE WHERE SIDEWALK WIDTH IS LIMITED OR WHERE EXISTING POLES ARE CLOSE TO THE CURB.
7. TYPICAL POST MOUNTING HEIGHTS FROM GROUND TO BOTTOM OF SIGN PANEL ARE 7 OR 8 FT. OTHER HEIGHTS MAY BE REQUIRED WHEN SIGNS ARE MOUNTED ON STEEPER FALL OR CUT SLOPES.
8. "EDUCATIONAL PLAQUES" FOR SYMBOL SIGNS WILL NOT BE CONSIDERED WHEN DETERMINING VERTICAL PLACEMENT FOR SUPERIMPOSITION OF EDUCATIONAL PLAQUES. SEE PAGE 3 OF THE 2002 COST GUIDE SIGNING POLICIES & PROCEDURES, AND SECTION 10.01 OF THE 2009 MUTCD.
9. WHEN LATERAL PLACEMENT IS 30 FT OR MORE FOR SIGNS WITHOUT A SUPPLEMENTAL PLAQUE, VERTICAL PLACEMENT H MAY BE REQUIRED TO 8 FT WHEN LATERAL PLACEMENT IS 30 FT OR MORE FOR SIGNS WITH A SUPPLEMENTAL PANEL, VERTICAL PLACEMENT F DOES NOT APPLY - USE ONLY VERTICAL PLACEMENT H.
10. NORMAL AVERAGE PLACEMENT IS 0 DEG. SIGNS CLOSER THAN 30 FT. SHOULD BE TURNED SLIGHTLY AWAY TO MINIMIZE SPECULAR REFLECTION. SIGNS PLACED 30 FT. OR MORE SHOULD GENERALLY BE TURNED TOWARD THE ROAD.
11. THE EXIT PANEL IS MOUNTED ON THE RIGHT HAND SIDE FOR RIGHT HAND EXITS AND THE LEFT SIDE FOR LEFT HAND EXITS.
12. POST SHALL BE INSTALLED PLUMB, VERTICAL DEVIATION SHALL NOT EXCEED 1/2-IN. IN 10 FT.
13. ON ALL TWO-LANE UNDIVIDED HIGHWAYS, THE MILE MARKER AND POST SHALL BE INSTALLED ON THE RIGHT SHOULDER IN THE ASCENDING DIRECTION WITH THE MILE MARKER PANELS DISPLAYED ON THE FRONT AND BACK SIDE OF THE POST.
14. ON ALL UNDIVIDED MULTI-LANE AND DIVIDED HIGHWAYS, AND INTERSTATES, THE MILE MARKER AND POST SHALL BE INSTALLED ON THE OUTSIDE SHOULDER OR SIDEWALK IF APPLICABLE IN BOTH DIRECTIONS OF TRAVEL.
15. VERTICAL SPACING BETWEEN SIGN PANELS SHALL BE 1 TO 1 1/2 IN, TYPICAL.

PLACEMENT TABLES

LATERAL PLACEMENT		VERTICAL PLACEMENT						
ALL CLASSES OF STREETS AND HIGHWAYS		FREIGHTWAYS AND EXPRESSWAYS		CONVENTIONAL STREETS AND HIGHWAYS				
KEY		KEY		URBAN		RURAL		
	MINIMUM	MAX.	MIN.	MAX.	MIN.	MAX.		
A	2'-0"	15'-0" PLUS CURB	D	7'-0" OR NOTE NO. 9	12'-0"	7'-0"	8'-0"	5'-0"
B	2'-0"	30'-0" OR MORE (INCLUDES CURB)	E	7'-0"	8'-0"	7'-0"	8'-0"	5'-0"
C	2'-0"	6'-0" PLUS EDGE OF 8'+ WIDE SHOULDER, IF NONE, 15'-0" FROM EDGE OF TRAVEL LANE	F	8'-0" OR NOTE NO. 9	12'-0"	8'-0"	8'-0"	5'-0"
			G	8'-0"	7'-0"	8'-0"	7'-0"	4'-0"
			H	8'-0"	10'-0"	8'-0"	7'-0"	4'-0"

Computer File Information

Creation Date: 07/04/12
Created By: KCM
Last Modification Date: 07/31/19
Last Modified By: AVU
CAD Ver: MicroStation V8
Scale: Not to Scale
Units: English

Sheet Revisions

Date:	Comments:

Colorado Department of Transportation
 2829 W. Howard Pl.
 Denver, CO 80204
 Phone: 303-737-8436
 Fax: 303-757-9219

Traffic & Safety Engineering MKB

GROUND SIGN PLACEMENT

Issued By: Traffic & Safety Engineering Branch July 31, 2019

STANDARD PLAN NO.
S-614-1
Standard Sheet No. 1 of 2
 Project Sheet Number:

**TUBULAR STEEL POSTS
(SOCKET SYSTEM) (FOR USE WITH ALL P-POST INSTALLATIONS)
(SEE SHEET 2 FOR P1 AND P2 POST INSTALLATIONS)**

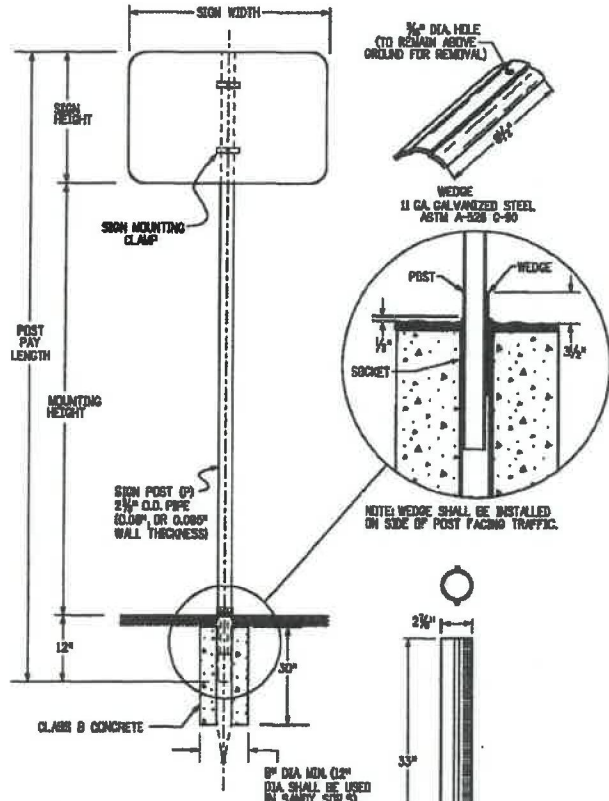

POST NOTES

THE POST MAY BE PRE-PUNCHED WITH 3/4\"/>

P1, 3\", 3 1/2\", 3 3/4\", 4\", 4 1/2\", 4 3/4\", 5\", 5 1/2\", 5 3/4\", 6\", 6 1/2\", 6 3/4\", 7\", 7 1/2\", 7 3/4\", 8\", 8 1/2\", 8 3/4\", 9\", 9 1/2\", 9 3/4\", 10\", 10 1/2\", 10 3/4\", 11\", 11 1/2\", 11 3/4\", 12\"/>

TUBULAR CONCRETE FOOTING
12 GA GALVANIZED
STEEL ASTM - 767

**SIGNPOST SELECTION GUIDE (90 MPH WIND LOAD DESIGN)
(FOR SOCKET SYSTEM AND SLIPBASE INSTALLATIONS USING P, P1 OR P2 POSTS)**

SIGN HEIGHT (FT)	7' MOUNTING HEIGHT									8' MOUNTING HEIGHT									9' MOUNTING HEIGHT											
	SIGN WIDTH (FT)									SIGN WIDTH (FT)									SIGN WIDTH (FT)											
	1	2	2.5	3	4	5	6	7	8	9	1	2	2.5	3	4	5	6	7	8	9	1	2	2.5	3	4	5	6	7	8	9
1	P	P	P	P	P	P1	SIZES NOT USED			SIZES NOT USED									SIZES NOT USED											
2	P	P	P	P	P	P1	SIZES NOT USED			SIZES NOT USED									SIZES NOT USED											
2.5	P	P	P	P	P1	P1	SIZES NOT USED			SIZES NOT USED									SIZES NOT USED											
3	P	P	P	P1	P1	P1	SIZES NOT USED			SIZES NOT USED									SIZES NOT USED											
4	P	P1	P1	P1	P1	P1	SIZES NOT USED			SIZES NOT USED									SIZES NOT USED											
5	SIZES NOT USED			P1	P1	P1	P1	SIZES NOT USED			SIZES NOT USED									SIZES NOT USED										
6	SIZES NOT USED			P1	P1	P1	P2	SIZES NOT USED			SIZES NOT USED									SIZES NOT USED										
7	SIZES NOT USED			P1	P1	P2	SIZES NOT USED			SIZES NOT USED									SIZES NOT USED											

SEE CHART NOTE 4.

CHART NOTES

- TYPICAL POST MOUNTING HEIGHTS FROM GROUND TO BOTTOM OF SIGN PANEL ARE 7, 8 OR 9 FEET. OTHER HEIGHTS MAY BE REQUIRED WHEN SIGNS ARE MOUNTED ON STEEPER HILL OR CUT SLOPES.
- FOR SIGNS MOUNTED ON TWO POSTS, THE MINIMUM DISTANCE BETWEEN POSTS SHALL BE 2 FEET AND THE MAXIMUM DISTANCE SHALL BE 8 FEET. DISTANCE FROM POST TO EDGE OF SIGN PANEL(S) SHALL BE 0 TO 4 INCHES. WHEN BACKING ZEES ARE USED, POSTS SHALL BE INSTALLED WITH A MINIMUM OF 2 INCHES TO THE EDGE OF THE BACKING ZEE.
- ALL SIGN PANELS GREATER THAN 60 INCHES IN WIDTH MUST BE MOUNTED ON TWO POSTS TO PREVENT TURNING.
- THE POST SIZES SHOWN ARE THE MINIMUM SIZES REQUIRED. TWO P1 POSTS MAY BE SUBSTITUTED WHERE ONE P2 POST IS INDICATED. P2 POSTS MAY BE SUBSTITUTED FOR P1 POSTS WHEN DIRECTED BY THE ENGINEER.

GENERAL NOTES

- SIGNS BETWEEN 37 IN. AND 60 IN. WIDTH WITH ONE POST INSTALLATION REQUIRE A T OR U SIGN SUPPORT BRACKET IN ADDITION TO THE BACKING ZEE REQUIREMENTS. WHEN DIRECTED BY THE ENGINEER, SIGN PANELS LESS THAN 48 IN. IN WIDTH MAY ATTACHED DIRECTLY TO T OR U BRACKETS WITHOUT ZEES.
- U-BRACKETS MAY BE USED FOR MULTIPLE SIGN INSTALLATIONS.
- FOR BACKING ZEE REQUIREMENTS AND DETAILS, SEE STANDARD PLANS S-614-3 AND S-614-4.
- THE CONTRACTOR SHALL INSTALL THE POSTS PER THE MANUFACTURER'S RECOMMENDATIONS WITHOUT ADDITIONAL COMPENSATION.

POST SPECIFICATIONS

POST SIZE	OUTSIDE DIAMETER	WALL THICKNESS	MATERIAL	COATING	MAX ALLOW MOMENT	PAID FOR AS:
P	2.575"	.080"	ASTM-513	ASTM A-663 G-910 WITH 3.0 MIL POLYMER COATING PER ASTM A123 CLEAR COATING	1.47 KIP FT	STEEL SIGN SUPPORT (2 INCH ROUND)
P1	2.675"	.100"	ASTM-513	GC HOT DIPPED PER ASTM-123	4.02 KIP FT	STEEL SIGN SUPPORT (2 1/2 INCH ROUND NF-40)
P2	2.675"	.276"	ASTM-600	GC HOT DIPPED PER ASTM-123	5.13 KIP FT	STEEL SIGN SUPPORT (2 1/2 INCH ROUND SCH 80)

** COLOR POWDER COATING MAY BE ADDED ACCORDING TO MANUFACTURER SPECIFICATIONS FOR SPECIAL LOCATIONS WHEN SHOWN ON THE PLANS.

Computer File Information	
Creation Date:	07/04/12
Created By:	KEN
Last Modification Date:	07/31/19
Last Modified By:	AVU
CAD Ver.:	MicroStation VB Scalar Not to Scale United English

Sheet Revisions	
Date:	Comments:

Colorado Department of Transportation
2829 W. Howard Pl.
Denver, CO 80204
Phone: 303-757-8438
Fax: 303-757-6219

Traffic & Safety Engineering MKB

**TUBULAR STEEL SIGN
SUPPORT DETAILS**

Issued By: Traffic & Safety Engineering Branch July 31, 2019

**STANDARD PLAN NO.
S-614-8**

Standard Sheet No. 1 of 7

Project Sheet Number

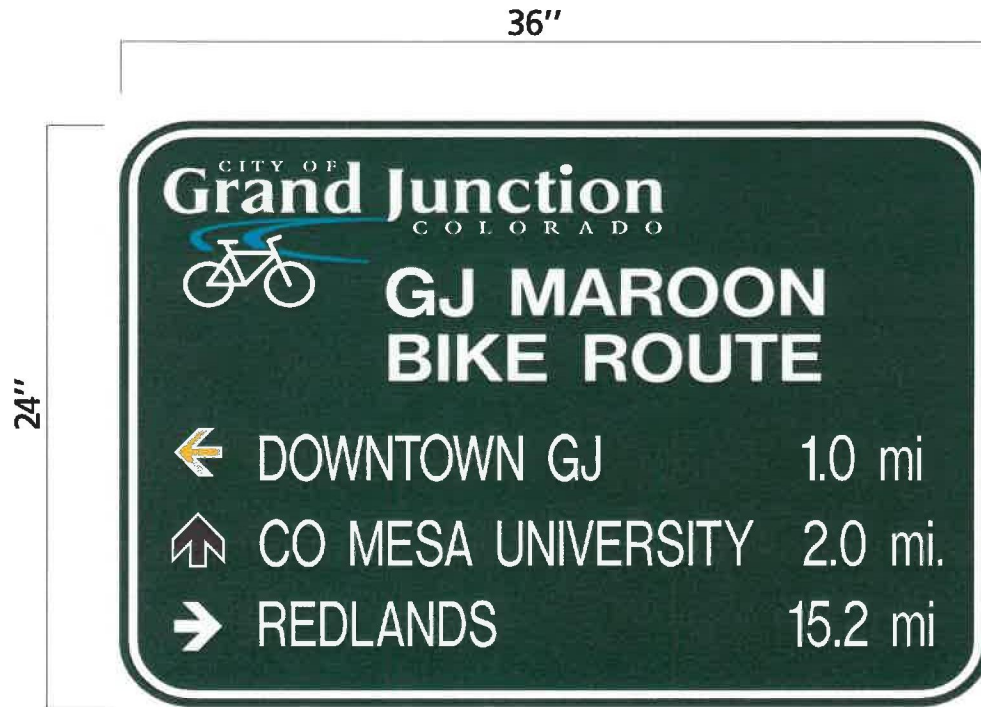

BIKE TRAIL SIGN

OPTION 1

(SQUARE SHAPE SINGLE/MULTI ARROW COLOR)

