



Purchasing Division

Invitation for Bid

IFB-4898-21-DH

Slide Gate Purchase for Hogchute Dam
Improvements

Responses Due:

April 2, 2021 prior to 3:00 PM MDT

Accepting Electronic Responses Only

**Responses Only Submitted Through the Rocky Mountain E-Purchasing
System (RMEPS)**

<https://www.rockymountainbidsystem.com/default.asp>

(Purchasing Representative does not have access or control of the vendor side of RMEPS. If website or other problems arise during response submission, vendor **MUST** contact RMEPS to resolve issue prior to the response deadline. 800-835-4603)

IMPORTANT NOTICE:

Due to the recent developments with increased COVID-19 cases in Mesa County, public in-person bid openings are temporarily being suspended. Bid openings will still take place on their designated date and time virtually, and bid tabulations will still be posted for public view/access. Once the crisis has passed, public in-person bid openings will resume as normal. Attached is the virtual link and information to attend the bid opening. Public may addend through the link, or via phone.

Purchasing Representative:

Duane Hoff Jr., Senior Buyer

duaneh@gjcity.org

Phone (970) 244-1545

This document has been developed specifically to solicit competitive responses for this solicitation, and may not be the same as previous City of Grand Junction solicitations. All vendors are urged to thoroughly review this solicitation prior to responding. Submittal by **FAX, EMAIL or HARD COPY IS NOT ACCEPTABLE** for this solicitation.

Invitation for Bids

Table of Contents

Section 1	Instruction to Bidders
Section 2	General Contract Conditions
Section 3	Statement of Work
Section 4	Bid Form
	Price Proposal/Bid Schedule Form

1. Instructions to Bidders

- 1.1. **Purpose:** The City of Grand Junction is soliciting competitive bids from qualified and interested companies for all labor, equipment, and materials required to provide and deliver pipe and related supplies to provide a slide gate and hydraulic controls for Hogchute Dam. All dimensions and scope of work should be verified by Bidders prior to submission of bids.

The City would like to remind all Contractors, Sub-Contractors, Vendors, Suppliers, Manufacturers, Service Providers, etc. that (with the exception of Pre-Bid or Site Visit Meetings) all questions, inquiries, comments, or communication pertaining to any formal solicitation (whether process, specifications, scope, etc.) must be directed (in writing) to the Purchasing Agent assigned to the project, or Purchasing Division. Direct communication with the City assigned Project Managers/Engineers is not appropriate for public procurement, and may result in disqualification.

- 1.2. **The Owner:** The Owner is the City of Grand Junction, Colorado and is referred to throughout this Solicitation. The term Owner means the Owner or his authorized representative.

- 1.3. **Procurement Process:** Procurement processes shall be governed by the most current version of the City of Grand Junction [Purchasing Policy and Procedure Manual](#).

- 1.4. **Submission:** **Each proposal shall be submitted in electronic format only, and only through the Rocky Mountain E-Purchasing website (<https://www.rockymountainbidsystem.com/default.asp>).** *This site offers both “free” and “paying” registration options that allow for full access of the Owner’s documents and for electronic submission of proposals. (Note: “free” registration may take up to 24 hours to process. Please Plan accordingly.)* Please view our “**Electronic Vendor Registration Guide**” at <https://co-grandjunction.civicplus.com/501/Purchasing-Bids> for details. (Purchasing Representative does not have access or control of the vendor side of RMEPS. If website or other problems arise during response submission, vendor **MUST** contact RMEPS to resolve issue prior to the response deadline. **800-835-4603**)

Please join Solicitation Opening - IFB-4898-21-DH, Slide Gate Purchase for Hogchute Dam Improvements on GoToConnect from your computer using the Chrome browser.

<https://my.jive.com/meet/171540189>

You can also dial in using your phone.

US: (571) 317-3116

Access Code: 171-540-189

- 1.5. **Printed Form for Price Bid:** All Price Bids must be made upon the Bid Form attached, and should give the amounts both in words and in figures, and must be signed and acknowledged by the bidder.
- 1.6. **Exclusions:** No oral, telephonic, emailed, or facsimile bid will be considered
- 1.7. **Contract Documents:** The complete IFB and bidder's response compose the Contract Documents. Copies of these documents can be obtained from the City Purchasing website, <https://co-grandjunction.civicplus.com/501/Purchasing-Bids>.
- 1.8. **Examination of Specifications:** Bidders shall thoroughly examine and be familiar with the project Statement of Work. The failure or omission of any Bidder to receive or examine any form, addendum, or other document shall in no way relieve any Bidder from any obligation with respect to his bid. The submission of a bid shall be taken as evidence of compliance with this section.
- 1.9. **Questions Regarding Statement of Work:** Any information relative to interpretation of Scope of Work or specifications shall be requested of the Purchasing Representative, in writing, in ample time prior to the response time.
- 1.10. **Addenda & Interpretations:** All Questions shall be submitted in writing to the appropriate person as shown in Section 1.1. Any interpretations, corrections and changes to this solicitation or extensions to the opening/receipt date shall be made by a written Addendum to the solicitation by the Owner. Sole authority to authorize addenda shall be vested in the Purchasing Representative. Addenda will be issued electronically through the Rocky Mountain E-Purchasing website at www.rockymountainbidsystem.com. Bidders shall acknowledge receipt of all addenda in their response and are solely responsible for obtaining all solicitation documents.
- 1.11. **Taxes:** The Owner is exempt from State retail and Federal tax. The bid price must be net, exclusive of taxes.
- 1.12. **Offers Binding 60 Days:** Unless otherwise specified, all formal offers submitted shall be binding for sixty (60) calendar days following opening date, unless the Bidder, upon request of the Purchasing Representative, agrees to an extension.
- 1.13. **Collusion Clause:** Each bidder by submitting a bid certifies that it is not party to any collusive action or any action that may be in violation of the Sherman Antitrust Act. Any and all bids shall be rejected if there is evidence or reason for believing that collusion exists among bidders. The Owner may, or may not, accept future bids for the same services or commodities from participants in such collusion.
- 1.14. **Public Disclosure Record:** If the bidder has knowledge of their employee(s) or sub-contractors having an immediate family relationship with an Owner employee or elected official, the bidder must provide the Purchasing Representative with the name(s) of these individuals. These individuals are required to file an acceptable "Public Disclosure Record", a statement of financial interest, before conducting business with the Owner.

- 1.15. **Public Opening:** Responses shall be opened in the City Hall Auditorium 250 North 5th Street, Grand Junction, CO 81501 immediately following the solicitation deadline.

2. General Contract Conditions

- 2.1. **The Contract:** This Invitation for Bid, submitted documents, and any negotiations, when properly accepted by the Owner, shall constitute a contract equally binding between the Owner and Bidder. The contract represents the entire and integrated agreement between the parties hereto and supersedes all prior negotiations, representations, or agreements. The contract may be amended or modified with Change Orders, Field Orders, or Amendment(s).
- 2.2. **Execution, Correlation, Intent, and Interpretations:** The Contract Documents and/or Purchase Order shall be signed by the Owner (Owner) and Contractor. Owner will provide the contract/purchase order. By executing the contract/purchase order, the Bidder represents that they have familiarized themselves with the local conditions under which the work is to be performed, and correlated his observations with the requirements of the Contract Documents. The Contract Documents are complementary, and what is required by any one, shall be as binding as if required by all. The intention of the documents is to include all labor, materials, equipment and other items necessary for the proper execution and completion of the scope of work as defined herein. All drawings, specifications and copies furnished by the Owner are, and shall remain, Owner property. They are not to be used on any other project, and with the exception of one contract set for each party to the contract, are to be returned to the owner on request at the completion of the work.
- 2.3. **The Owner:** The Owner is the City of Grand Junction, Colorado and is referred to throughout the Contract Documents. The term Owner means the Owner or his authorized representative. The Owner shall, at all times, have access to the work wherever it is in preparation or progress. The Contractor shall provide facilities for such access. The Owner will familiarize himself generally with the progress and quality of work and to determine, in general, if the work is proceeding in accordance with the contract documents. The Owner will not be responsible for the acts or omissions of the Contractor, and sub-Contractor, or any of their agents or employees, or any other persons performing any of the work.
- 2.4. **Contractor:** The Contractor is the person or organization identified as such in the Agreement and is referred to throughout the Contract Documents. The term Contractor means the Contractor or his authorized representative. The Contractor shall carefully study and compare the General Contract Conditions of the Contract, Specification and/or Drawings, Scope of Work, Addenda and Modifications and shall at once report to the Owner any error, inconsistency or omission he may discover. Contractor shall not be liable to the Owner for any damage resulting from such errors, inconsistencies or omissions. The Contractor shall not commence work without clarifying Drawings, Specifications, or Interpretations.

2.5. Warranty: The Contractor warrants to the Owner that all materials and equipment furnished under this contract will be new unless otherwise specified, be of good quality, free from faults and defects and in conformance with the Contract Documents. All materials and equipment not so conforming to these standards may be considered defective. If required by Owner, the Contractor shall furnish satisfactory evidence as to the kind and quality of materials and equipment. If within ten (10) days after written notice to the Contractor requesting such repairs or replacement, the Contractor should neglect to make or undertake with due diligence to the same, the City may make such replacements. All indirect and direct costs of such correction or replacement shall be at the Contractor's expense.

2.6. Insurance Requirements: The selected Contractor agrees to procure and maintain, at its own cost, policy(s) of insurance sufficient to insure against all liability, claims, demands, and other obligations assumed by the Contractor pursuant to this Section. Such insurance shall be in addition to any other insurance requirements imposed by this Contract or by law. The Contractor shall not be relieved of any liability, claims, demands, or other obligations assumed pursuant to this Section by reason of its failure to procure or maintain insurance in sufficient amounts, durations, or types. Contractor shall procure and maintain and, if applicable, shall cause any Subcontractor of the Contractor to procure and maintain insurance coverage listed below. Such coverage shall be procured and maintained with forms and insurers acceptable to the Owner. In the case of any claims-made policy, the necessary retroactive dates and extended reporting periods shall be procured to maintain such continuous coverage. Minimum coverage limits shall be as indicated below unless specified otherwise:

(a) Worker Compensation: Contractor shall comply with all State of Colorado Regulations concerning Workers' Compensation insurance coverage.

(b) General Liability insurance with minimum limits of:

ONE MILLION DOLLARS (\$1,000,000) each occurrence and
ONE MILLION DOLLARS (\$1,000,000) per job aggregate.

The policy shall be applicable to all premises and operations. The policy shall include coverage for bodily injury, broad form property damage (including completed operations), personal injury (including coverage for contractual and employee acts), blanket contractual, products, and completed operations. The policy shall include coverage for explosion, collapse, and underground hazards. The policy shall contain a severability of interests provision.

(c) Comprehensive Automobile Liability insurance with minimum limits for bodily injury and property damage of not less than:

ONE MILLION DOLLARS (\$1,000,000) each occurrence and
ONE MILLION DOLLARS (\$1,000,000) aggregate

With respect to each of Contractors owned, hired, or non-owned vehicles assigned to be used in performance of the Work. The policy shall contain a severability of interests provision. The policies required by paragraph (b) above shall be

endorsed to include the Owner, and the Owner's officers and employees as additional insureds. Every policy required above shall be primary insurance, and any insurance carried by the Owner, its officers, or its employees, or carried by or provided through any insurance pool of the Owner, shall be excess and not contributory insurance to that provided by Bidder. No additional insured endorsement to any required policy shall contain any exclusion for bodily injury or property damage arising from completed operations. The Bidder shall be solely responsible for any deductible losses under any policy required above.

- 2.7. Indemnification:** The Contractor shall defend, indemnify and save harmless the Owner, and all its officers, employees, insurers, and self-insurance pool, from and against all liability, suits, actions, or other claims of any character, name and description brought for or on account of any injuries or damages received or sustained by any person, persons, or property on account of any negligent act or fault of the Contractor, or of any Contractor's agent, employee, sub-contractor or supplier in the execution of, or performance under, any contract which may result from proposal award. Contractor shall pay any judgment with cost which may be obtained against the Owner growing out of such injury or damages.
- 2.8. Miscellaneous Conditions:** Material Availability: Contractors must accept responsibility for verification of material availability, production schedules, and other pertinent data prior to submission of bid. It is the responsibility of the bidder to notify the Owner immediately if materials specified are discontinued, replaced, or not available for an extended period of time. OSHA Standards: All bidders agree and warrant that services performed in response to this invitation shall conform to the standards declared by the US Department of Labor under the Occupational Safety and Health Act of 1970 (OSHA). In the event the services do not conform to OSHA standards, the Owner may require the services to be redone at no additional expense to the Owner.
- 2.9. Time:** The Contract Time is the period of time allotted in the Contract Documents for completion of product/material receipt. The date of commencement of the contract is the date established in the Contract Documents.
- 2.10. Payment & Completion:** The Contract Sum is stated in the Contract and is the total amount payable by the Owner to the Contractor for the products/materials under the Contract Documents. Upon receipt of the products/materials or written notice that the products/materials is ready for final inspection and acceptance and upon receipt of application for payment, the Owner's Project Manager will promptly make such inspection and, when he finds the products/materials acceptable under the Contract Documents and the Contract fully performed, the Owner shall make payment in the manner provided in the Contract Documents.
- 2.11. Protection of Persons & Property:** The Contractor shall comply with all applicable laws, ordinances, rules, regulations and orders of any public authority having jurisdiction for the safety of persons or property or to protect them from damage, injury or loss. Contractor shall erect and maintain, as required by existing safeguards for safety and protection, and all reasonable precautions, including posting danger signs or other warnings against hazards promulgating safety regulations and notifying owners and users of adjacent utilities. When or where

any direct or indirect damage or injury is done to public or private property by or on account of any act, omission, neglect, or misconduct by the Contractor in the execution of the Contract, or in consequence of the non-execution thereof, the Contractor shall restore, at their own expense, such property to a condition similar or equal to that existing before such damage or injury was done, by repairing, rebuilding, or otherwise restoring as may be directed, or they shall make good such damage or injury in an acceptable manner.

- 2.19. Change Order/Amendment:** No oral statement of any person shall modify or otherwise change, or affect the terms, conditions or specifications stated in the resulting contract. All Change Orders/Amendments to the contract shall be made in writing by the Owner.
- 2.20. Assignment:** The Contractor shall not sell, assign, transfer or convey any contract resulting from this Solicitation, in whole or in part, without the prior written approval from the Owner.
- 2.21. Cancellation of Solicitation:** Any solicitation may be canceled by the Owner or any solicitation response by a vendor may be rejected in whole or in part when it is in the best interest of the Owner.
- 2.22. Compliance with Laws:** Bids must comply with all Federal, State, County and local laws governing or covering this type of service and the fulfillment of all ADA (Americans with Disabilities Act) requirements.
- 2.23. Confidentiality:** All materials submitted in response to this Solicitation shall ultimately become public record and shall be subject to inspection after contract award. “**Proprietary or Confidential Information**” is defined as any information that is not generally known to competitors and which provides a competitive advantage. Unrestricted disclosure of proprietary information places it in the public domain. Only submittal information clearly identified with the words “**Confidential Disclosure**” and uploaded as a separate document shall establish a confidential, proprietary relationship. Any material to be treated as confidential or proprietary in nature must include a justification for the request. The request shall be reviewed and either approved or denied by the Owner. If denied, the proposer shall have the opportunity to withdraw its entire proposal, or to remove the confidential or proprietary restrictions. Neither cost nor pricing information nor the total response shall be considered confidential or proprietary.
- 2.24. Conflict of Interest:** No public official and/or Owner employee shall have interest in any contract resulting from this Solicitation.
- 2.25. Contract Termination:** This contract shall remain in effect until any of the following occurs: (1) contract expires; (2) completion of work; (3) acceptance of work or, (4) for convenience terminated by either party with a written *Notice of Cancellation* stating therein the reasons for such cancellation and the effective date of cancellation.

- 2.26. Employment Discrimination:** During the performance of any services per agreement with the Owner, the Contractor, by submitting a response, agrees to the following conditions:
- 2.26.1.** The Contractor shall not discriminate against any employee or applicant for employment because of race, religion, color, sex, age, handicap, or national origin except when such condition is a legitimate occupational qualification reasonably necessary for the normal operations of the Contractor. The Contractor agrees to post in conspicuous places, visible to employees and applicants for employment, notices setting forth the provisions of this nondiscrimination clause.
 - 2.26.2.** The Contractor, in all solicitations or advertisements for employees placed by or on behalf of the Contractor, shall state that such Contractor is an Equal Opportunity Employer.
 - 2.26.3.** Notices, advertisements, and solicitations placed in accordance with federal law, rule, or regulation shall be deemed sufficient for the purpose of meeting the requirements of this section.
- 2.27. Immigration Reform and Control Act of 1986 and Immigration Compliance:** The Contractor certifies that it does not and will not during the performance of the contract employ illegal alien workers or otherwise violate the provisions of the Federal Immigration Reform and Control Act of 1986 and/or the immigration compliance requirements of State of Colorado C.R.S. § 8-17.5-101, *et seq.* (House Bill 06-1343).
- 2.28. Ethics:** The Contractor shall not accept or offer gifts or anything of value nor enter into any business arrangement with any employee, official, or agent of the Owner.
- 2.29. Failure to Deliver:** In the event of failure of the Contractor to deliver products/materials in accordance with the contract terms and conditions, the Owner, after due oral or written notice, may procure the products/materials from other sources and hold the Contractor responsible for any costs resulting in additional purchase and administrative services. This remedy shall be in addition to any other remedies that the Owner may have.
- 2.30. Failure to Enforce:** Failure by the Owner at any time to enforce the provisions of the contract shall not be construed as a waiver of any such provisions. Such failure to enforce shall not affect the validity of the contract or any part thereof or the right of the Owner to enforce any provision at any time in accordance with its terms.
- 2.31. Force Majeure:** The Contractor shall not be held responsible for failure to perform the duties and responsibilities imposed by the contract due to legal strikes, fires, riots, rebellions, and acts of God beyond the control of the Contractor, unless otherwise specified in the contract.
- 2.32. Independent Contractor:** The Contractor shall be legally considered an Independent Contractor and neither the Contractor nor its employees shall, under any circumstances, be considered servants or agents of the Owner. The Owner

shall be at no time legally responsible for any negligence or other wrongdoing by the Contractor, its servants, or agents. The Owner shall not withhold from the contract payments to the Contractor any federal or state unemployment taxes, federal or state income taxes, Social Security Tax or any other amounts for benefits to the Contractor. Further, the Owner shall not provide to the Contractor any insurance coverage or other benefits, including Workers' Compensation, normally provided by the Owner for its employees.

- 2.33. Nonconforming Terms and Conditions:** A response that includes terms and conditions that do not conform to the terms and conditions of this Solicitation is subject to rejection as non-responsive. The Owner reserves the right to permit the Contractor to withdraw nonconforming terms and conditions from its response prior to a determination by the Owner of non-responsiveness based on the submission of nonconforming terms and conditions.
- 2.34. Ownership:** All plans, prints, designs, concepts, etc., shall become the property of the Owner.
- 2.35. Patents/Copyrights:** The Contractor agrees to protect the Owner from any claims involving infringements of patents and/or copyrights. In no event shall the Owner be liable to the Contractor for any/all suits arising on the grounds of patent(s)/copyright(s) infringement. Patent/copyright infringement shall null and void any agreement resulting from response to this Solicitation.
- 2.36. Remedies:** The Contractor and Owner agree that both parties have all rights, duties, and remedies available as stated in the Uniform Commercial Code.
- 2.37. Venue:** Any agreement as a result of responding to this Solicitation shall be deemed to have been made in, and shall be construed and interpreted in accordance with, the laws of the City of Grand Junction, Mesa County, Colorado.
- 2.38. Expenses:** Expenses incurred in preparation, submission and presentation of this Solicitation are the responsibility of the company and cannot be charged to the Owner.
- 2.39. Sovereign Immunity:** The Owner specifically reserves its right to sovereign immunity pursuant to Colorado State Law as a defense to any action arising in conjunction to this agreement.
- 2.40. Non-Appropriation of Funds:** The contractual obligation of the Owner under this contract is contingent upon the availability of appropriated funds from this fiscal year budget as approved by the City Council or Board of County Commissioners from this fiscal year only. **State of Colorado Statutes prohibit obligation of public funds beyond the fiscal year for which the budget was approved.** Anticipated expenditures/obligations beyond the end of the current Owner's fiscal year budget shall be subject to budget approval. Any contract shall be subject to, and must contain, a governmental non-appropriation of funds clause.
- 2.41. Cooperative Purchasing:** Purchases as a result of this solicitation are primarily for the Owner. Other governmental entities may be extended the opportunity to

utilize the resultant contract award with the agreement of the successful provider and the participating agencies. All participating entities shall be required to abide by the specifications, terms, conditions and pricings established in this Solicitation. The quantities furnished in this bid document are for only the Owner. It does not include quantities for any other jurisdiction. The Owner shall be responsible only for the award for its jurisdiction. Other participating entities shall place their own awards on their respective Contract/Purchase Orders through their Purchasing Office or use their Purchasing Card for purchase/payment as authorized or agreed upon between the provider and the individual entity. The Owner accepts no liability for payment of orders placed by other participating jurisdictions that choose to piggy-back on our solicitation. Orders placed by participating jurisdictions under the terms of this solicitation shall indicate their specific delivery and invoicing instructions.

- 2.42. Keep Jobs in Colorado Act:** Contractor shall be responsible for ensuring compliance with Article 17 of Title 8, Colorado Revised Statutes requiring 80% Colorado labor to be employed on public works. Contractor shall, upon reasonable notice provided by the Owner, permit the Owner to inspect documentation of identification and residency required by C.R.S. §8-17-101(2)(a). If Contractor claims it is entitled to a waiver pursuant to C.R.S. §8-17-101(1), Contractor shall state that there is insufficient Colorado labor to perform the work such that compliance with Article 17 would create an undue burden that would substantially prevent a project from proceeding to completion, and shall include evidence demonstrating the insufficiency and undue burden in its response.

Unless expressly granted a waiver by the Owner pursuant to C.R.S. §8-17-101(1), Contractor shall be responsible for ensuring compliance with Article 17 of Title 8, Colorado Revised Statutes requiring 80% Colorado labor to be employed on public works. Contractor shall, upon reasonable notice provided by the Owner, permit the Owner to inspect documentation of identification and residency required by C.R.S. §8-17-101(2)(a).

2.42.1. "Public Works Project" is defined as:

- (a) any construction, alteration, repair, demolition, or improvement of any land, building, structure, facility, road, highway, bridge, or other public improvement suitable for and intended for use in the promotion of the public health, welfare, or safety and any maintenance programs for the upkeep of such projects
- (b) for which appropriate or expenditure of moneys may be reasonably expected to be \$500,000.00 or more in the aggregate for any fiscal year
- (c) except any project that receives federal moneys.

2.43. Definitions:

2.43.1. The term "Work" includes all labor, materials, equipment, and/or services necessary to produce the requirements of the Contract Documents.

2.43.2. "Contractor" is the person or organization identified as such in the Agreement and is referred to throughout the Contract Documents. The term Contractor means the Contractor or his authorized representative. The Contractor shall carefully study and compare the General Contract Conditions of the Contract, Specification and Drawings, Scope of Work,

Addenda and Modifications and shall at once report to the Owner any error, inconsistency or omission he may discover. Contractor shall not be liable to the Owner for any damage resulting from such errors, inconsistencies or omissions. The Contractor shall not commence work without clarifying Drawings, Specifications, or Interpretations.

- 2.43.3.** “Sub-Contractor is a person or organization who has a direct contract with the Contractor to perform any of the work at the site. The term sub-contractor is referred to throughout the contract documents and means a sub-contractor or his authorized representative.

3. Specifications and Special Conditions & Provisions

- 3.1. General:** The City of Grand Junction is accepting competitive bids, from qualified and interested companies, to supply and deliver a **36”x 36” Stainless Steel Slide Gate and hydraulic controls that meet the specifications listed in Section 3 “Specifications and Special Conditions”**.

No installation is required for this purchase. This is a products/materials purchase only.

Delivery costs of the product to the City of Grand Junction must be included in the bid price.

- 3.2. Specifications:** See attached Section 35 22 28 for Product Specifications, and drawings.

- 3.3. Special Conditions & Provisions:**

3.3.1 Materials Specifications Sheet: Bidders shall supply materials specifications sheets and MSDS (Material Safety Data Sheets) for all products proposed for bid, with their bid submittals.

3.3.2 Rejection of Products/Supplies: The City of Grand Junction reserves the right to return products/supplies due to product flaws and/or not meeting specifications. Judgment of non-conformity will be at the discretion of the City of Grand Junction Project Manager or representative of the City.

3.3.3 Delivery Schedule: Delivery shall be not later than July 30, 2021.

Lead times for major components such as slide gate and operator shall be noted in bid responses.

3.3.4 Delivery Location: The order of materials shall be delivered to City of Grand Junction Stores (Warehouse) located at 333 West Avenue, Building C, Grand Junction, CO 81501 ******Please call before delivery to verify proper location of material drop. **** Chris Packard, Warehouse Specialist 970-244-1576 or John Eklund, Project Engineer 970-244-1558.**

3.3.5 Price: Pricing shall be all inclusive, to include, but not be limited to: materials, shipping/freight, etc.

All prices shall be "F.O.B. Destination Freight Pre-Paid and Allowed". The Owner shall not pay nor be liable for any other additional costs including but not limited to: taxes, shipping charges, insurance, interest, penalties, termination payments, attorney fees, liquidated damages, etc.

3.3.6 Contract: A binding contract shall consist of: (1) the IFB and any amendments thereto, (2) the bidder's response (bid) to the IFB, (3) clarification of the bid, if any, and (4) the City's Purchasing Department's acceptance of the bid by "Notice of Award" or by "Purchase Order". All Exhibits and Attachments included in the IFB shall be incorporated into the contract by reference.

A. The contract expresses the complete agreement of the parties and, performance shall be governed solely by the specifications and requirements contained therein.

B. Any change to the contract, whether by modification and/or supplementation, must be accomplished by a formal contract amendment signed and approved by and between the duly authorized representative of the bidder and the City Purchasing Division or by a modified Purchase Order prior to the effective date of such modification. The bidder expressly and explicitly understands and agrees that no other method and/or no other document, including acts and oral communications by or from any person, shall be used or construed as an amendment or modification to the contract.

3.4.10 Packing Slips or Delivery Tickets: All shipments or deliveries shall be accompanied by Packing Slips or Delivery Tickets, and shall contain the following information for each item delivered:

- The purchase order number
- The name of the article and stock number
- The quantity ordered
- The quantity shipped
- The quantity back ordered
- The name of the vendor(s)

3.3.7 Brand Name or Equal: Whenever in this bid invitation any particular materials, process, mechanism, and/or equipment are indicated, described or specified by patent, proprietary, or brand name, or by name of manufacturer, such wording will be deemed to be used for the purpose of facilitating minimum acceptable requirements and will be deemed to be followed by the words, "or equal". Proof satisfactory to the Owner must be provided by Bidder to show that the alternative product/equipment/vehicle is in fact, equal to specification requirements.

The Owner has determined that the brand name, model name/numbers meets the specifications as stated in the solicitation documents. These manufacturer's references are not intended to be restrictive but descriptive of the type and quality the Owner desires to purchase. Bids for similar manufactured items of like quality will be considered if the bid is fully noted with the manufacturer's brand name and model. The Owner reserves the right to determine products of equal value. Bidders will not be allowed to make unauthorized substitutions after award is made.

3.4. Contractor Bid Documents: For Contractor's convenience, the following is a list of forms/items to be submitted with the Contractor's bid response. However, should a form/item not be listed in this section, but required in the solicitation documents, it is the Contractor's responsibility to ensure all forms/items are submitted.

- **Contractor's Bid Form**
- **Price Bid Schedule**
- **Materials Specifications Sheets**
- **Proposed Delivery Schedule and description of lead times**

3.5. IFB Tentative Time Schedule:

- | | |
|--|----------------|
| • Invitation for Bids available | March 12, 2021 |
| • Inquiry deadline, no questions after this date | March 23, 2021 |
| • Addendum Posted | March 25, 2021 |
| • Submittal deadline for proposals | April 2, 2021 |
| • Contract execution | April 8, 2021 |

3.6. Questions Regarding Scope of Services:

Duane Hoff Jr., Senior Buyer
duaneh@gjcity.org

4. Contractor's Bid Form

Bid Date: _____

Project: IFB-4898-21-DH "Slide Gate Purchase for Hogchute Dam Improvements"

Bidding Company: _____

Name of Authorized Agent: _____

Email _____

Telephone _____ **Address** _____

City _____ **State** _____ **Zip** _____

The undersigned Bidder, in compliance with the Invitation for Bids, having examined the Instruction to Bidders, General Contract Conditions, Statement of Work, Specifications, and any and all Addenda thereto, having investigated the location of, and conditions affecting the proposed work, hereby proposes to furnish all labor, materials and supplies, and to perform all work for the Project in accordance with Contract Documents, within the time set forth and at the prices stated below. These prices are to cover all expenses incurred in performing the work required under the Contract Documents, of which this Contractor's Bid Form is a part.

The undersigned Contractor does hereby declare and stipulate that this offer is made in good faith without collusion or connection to any person(s) providing an offer for the same work, and that it is made in pursuance of, and subject to, all terms and conditions of the Instructions to Bidders, the Specifications, and all other Solicitation Documents, all of which have been examined by the undersigned.

The Contractor also agrees that if awarded the Contract, to provide insurance certificates within ten (10) working days of the date of Notification of Award. Submittal of this offer will be taken by the Owner as a binding covenant that the Contractor will be prepared to complete the project in its entirety.

The Owner reserves the right to make the award on the basis of the offer deemed most favorable, to waive any formalities or technicalities and to reject any or all offers. It is further agreed that this offer may not be withdrawn for a period of sixty (60) calendar days after closing time. Submission of clarifications and revised offers automatically establish a new thirty day (30) period.

Prices in the bid proposal have not knowingly been disclosed with another provider and will not be prior to award.

- Prices in this bid proposal have been arrived at independently, without consultation, communication or agreement for the purpose of restricting competition.
- No attempt has been made nor will be to induce any other person or firm to submit a bid proposal for the purpose of restricting competition.
- The individual signing this bid proposal certifies they are a legal agent of the offeror, authorized to represent the offeror and is legally responsible for the offer with regard to supporting documentation and prices provided.
- Direct purchases by the City of Grand Junction are tax exempt from Colorado Sales or Use Tax. Tax exempt No. 98-903544. The undersigned certifies that no Federal, State, County or Municipal tax will be added to the above quoted prices.
- City of Grand Junction payment terms shall be Net 30 days.
- Prompt payment discount of _____ percent of the net dollar will be offered to the Owner if the invoice is paid within _____ days after the receipt of the invoice.

RECEIPT OF ADDENDA: the undersigned Contractor acknowledges receipt of Addenda to the Solicitation, Specifications, and other Contract Documents.

State number of Addenda received: _____.

It is the responsibility of the Bidder to ensure all Addenda have been received and acknowledged.
By signing below, the Undersigned agree to comply with all terms and conditions contained herein.

Company: _____

Authorized Signature: _____

Title: _____

PRICE BID SCHEDULE: IFB-4898-21-DH Slide Gate Purchase for Hogchute Dam Improvements

Item	Est. Qty	Unit	Description	Unit Price	Total Price
1.	1	EA	Stainless Steel Slide Gate (36"x36") with Hydraulic control		
Total Price					

Proposed Delivery Schedule and description of lead times: _____

By signing below, the Undersigned agree to comply with all terms and conditions contained herein.

Company: _____

Authorized Signature: _____

Title: _____

SECTION 35 22 28

STAINLESS STEEL SLIDE GATES

PART 1 GENERAL

1.01 SUMMARY

- A. Provide stainless steel slide gates as shown and as specified. Comply with applicable provisions of Divisions 00 and 01.

1.02 RELATED SECTIONS

- 03 30 00 – Cast-in-Place Concrete.
- 33 42 15 – Piping and Accessories.

1.03 SUBMITTALS

- A. Shop Drawings: Submit shop drawings for slide gate and operator. Include hydraulic requirements for operator.
- B. Certification: Submit manufacturer's certification that slide gate and operator comply with the specified requirements.
- C. O/M Manuals: Submit operation and maintenance manuals for slide gate and operator.
- D. Make submittals in accordance with Section 01 33 00.

1.04 FIELD MEASUREMENTS

- A. Field verify dimensions prior to gate fabrication.

PART 2 PRODUCTS

2.01 ACCEPTABLE MANUFACTURERS

- A. Subject to compliance with the specified requirements, provide products by one of the following manufacturers, or approved equal:
 - 1. Golden Harvest.
 - 2. Hydro-Gate.
 - 3. Rodney Hunt.
 - 4. WACO Products.
 - 5. Whipps.

2.02 DESIGN REQUIREMENTS

- A. Design gates to comply with AWWA C561 and the following conditions.
- B. Gates shall have self-adjusting seals. Gates that utilize adjustable wedges are not acceptable.
- C. To compensate for debris strikes, gate bottom edge shall be designed to resist a static load of 1,000 lb per lin ft that is applied 3 in. above gate bottom lip.
- D. Gates shall be operable at variable gate open positions in increments of 0.10 ft to regulate flow. Gate shall be able to remain in any closed, partially open, or fully open position for long periods of time without excessive vibrations.
- E. Gates shall not vibrate excessively during opening, closing, or static positioning.

2.03 SLIDE GATES AND ACCESSORIES

- A. Provide fabricated stainless steel slide gates complying with AWWA C561 and 4.01 Stainless Steel Slide Gate Schedule.
- B. Gates designated for flush-bottom closure shall have a seal mounted either on gate slide or on gate frame. Full length of contacting member shall be accurately machined to make an effective seal when gate is closed.
- C. Provide stainless steel hydraulic lines per gate manufacturers recommendation.

2.04 MANUAL OPERATORS

- A. A hand-operated hydraulic pump shall be provided as back up operator.

2.05 PORTABLE HYDRAULIC OPERATOR

- A. One underwater (fully submerged) hydraulic operating system shall be provided to operate the gate. The system shall be designed to operate the gate smoothly and uniformly and hold the gate in the desired position. The gate shall be operated manually with a provided portable, gasoline-powered hydraulic pump mounted to a hand cart.
- B. Connections to hydraulic lines will be accessible via a locked valve box located at the top of the dam embankment.
- C. The hydraulic power unit (HPU) shall be designed to operate using environmentally-friendly (confirm with Owner prior to constructing HPU) hydraulic fluid such as Mobil 224H.
- D. Gate assembly shall have indicator device at operator location (top of dam) indicating position of gate in 0.10 ft increments.

2.06 GROUT AND FRAME LEAKAGE SEAL

- A. Grout furnished for installation of embedded components shall be as recommended by gate manufacturer for the site conditions.
- B. Frame to concrete connection shall be free of leakage. Acceptable leakage seals include a layer of grout between frame and existing concrete, rubberized membranes, or injectable waterstops. Design and furnishing of leakage seal materials shall be responsibility of gate manufacturer.

2.07 FINISH

- A. Ferrous metal surfaces shall receive surface preparation and high-solids epoxy protective coating or equivalent suitable for outdoor exposure before shipment to site.
- B. Machined surfaces, tapped holes, and threads shall receive protective coat of grease.

PART 3 EXECUTION

3.01 GATE INSTALLATION

- A. Install gates in accordance with shop drawings and manufacturer's recommendations and in a manner that will prevent leakage around seats and binding of gates during operation.
- B. Surfaces of metal against which concrete will be placed shall be free from oil, grease, loose mill scale, loose paint, surface rust, and other debris or objectionable coatings.
- C. Anchor bolts, thimbles, and frames shall be secured in true position and in forms and held in alignment during placement of concrete. Mechanical anchors shall not be installed into

concrete that is less than 7 days old. Adhesive anchors shall not be installed into concrete that is less than 21 days old.

- D. Concrete surfaces against which seals will bear or against which flat frames or plates are to be installed shall be smooth and uniform.
- E. Install frame and anchorages in a manner that prevents leakage between frame and concrete buttress and secures gate for all load conditions.
- F. When a gate is attached to a wall thimble, mastic or resilient gasket shall be applied between gate frame and thimble in accordance with recommendation of gate manufacturer.

3.02 LIFT INSTALLATION

- A. Gate stems, stem guides, and gate operators shall be carefully aligned so that stem is parallel to guide bars or angles on gate frame after installation.

3.03 OPERATIONAL TESTS

- A. Clean, lubricate, and otherwise service gates and operators in accordance with manufacturer's instructions. Operate each gate several times throughout its full range. Test functioning of each operator. Adjust as necessary to insure satisfactory operation of gate system.
- B. Should any gate vibrate excessively during opening, closing, or static positioning (see "Design Requirements" article above), manufacturer shall promptly attend a meeting onsite with A/E to discuss cause and solutions for vibrations.
- C. A certified field technician from the gate manufacturer shall inspect the final installation.

3.04 LEAKAGE TEST

- A. Perform a leakage test on all slide gates. Maximum permissible leakage at normal pool shall be 0.10 gallons per minute per foot of seating perimeter in compliance with AWWA C561, 5.2.2. Adjust gates to meet permissible leakage.

PART 4 SCHEDULES

4.01 STAINLESS STEEL SLIDE GATE SCHEDULE

<u>Quantity</u>	<u>Size (in.)*</u> <u>w x h</u>	<u>Stem*</u>	<u>Type*</u>	<u>Frame</u> <u>Type</u>	<u>Max. Unbalanced</u> <u>Head (ft)</u>		<u>Wall</u> <u>Thimble</u>	<u>Operation</u>
					<u>Seating</u>	<u>Unseating</u>		
1	36x36	HC	FB	Flange Frame	55	10	No	M and P

*Abbreviations:

Size: w - clear opening width, h - clear opening height

Stem: HC - hydraulic cylinder

Type: FB - flush bottom

Operation: M - manual P - portable hydraulic operator

END OF SECTION

CONSTRUCTION DRAWINGS FOR HOGCHUTE DAM REPAIRS

DAM ID NO. 420127 CONSTRUCTION NO. C-0454A

PREPARED FOR THE

CITY OF GRAND JUNCTION, MESA COUNTY, COLORADO WATER DIVISION 4, WATER DISTRICT 42

JANUARY 2021

CONTACT INFORMATION



OWNER

City of Grand Junction
John Eklund, P.E., C.F.M.
333 West Avenue, Building C
Grand Junction, Colorado 81501
(970) 244-1558



CIVIL ENGINEER

Ayres Associates
Dale Mathison, P.E.
3665 JFK Parkway, Building 2, Suite 100
Fort Collins, Colorado 80525
(970) 223-5556

F:\AAC2017CUI\GenBlocks\Colorado 811 Logo.JPG

THESE PLANS HAVE BEEN PREPARED BY ME OR UNDER MY DIRECT SUPERVISION.

DALE MATHISON
COLORADO P.E. NO. 0050522

APPROVED ON THE _____ DAY OF _____ 2020

STATE ENGINEER

BILL McCORMICK, CHIEF, COLORADO DAM SAFETY
COLORADO P.E. NO. 0029127

THESE PLANS REPRESENT THE AS-CONSTRUCTED CONDITIONS OF HOGCHUTE DAM REPAIRS TO THE BEST OF MY KNOWLEDGE AND JUDGMENT, BASED IN PART ON INFORMATION FURNISHED BY OTHERS, AS OF THE _____ DAY OF _____ 2020

DALE MATHISON
COLORADO P.E. NO. 0050522

VICINITY MAP

NOT TO SCALE

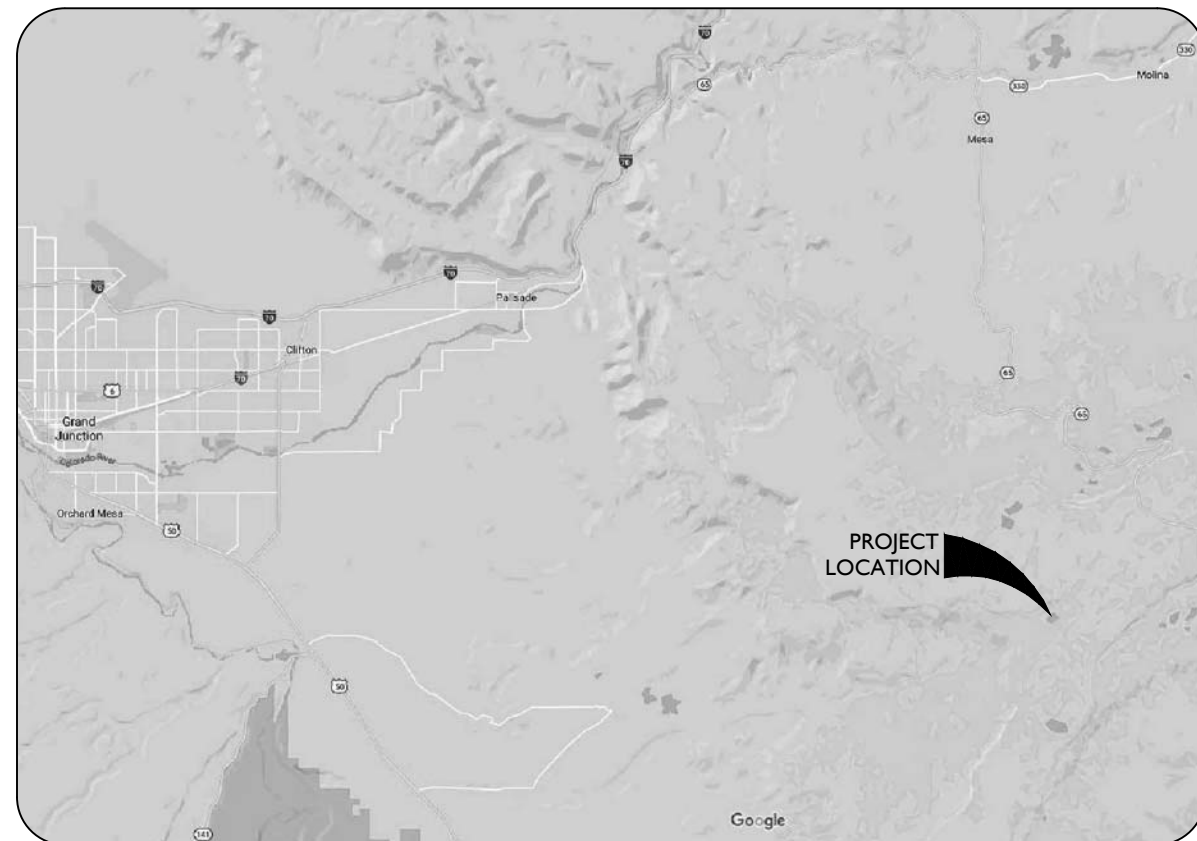

ONE INCH - IF NOT,
SCALE ACCORDINGLY



TITLE SHEET

HOGCHUTE DAM REPAIRS
CITY OF GRAND JUNCTION
MESA COUNTY, COLORADO

Revisions	Date
NOT FOR CONSTRUCTION	JAN 2021

Project Mgr. CTG	Designed By: AUS	Drawn By: RBR	Approved By: DAM	Date: 05/29/20
------------------	------------------	---------------	------------------	----------------

PROJECT NO.
26-1144.00
DRAWING NO.

G01

SHEET 1 OF 21

Drawing Name: I:\36\26-114400 GRAND JUNCTION HOGCHUTE DAM\MAINDWGS 2020\SHEETS\26-1144.00 SITE ACCESS.DWG Monday, January 11, 2021 10:59 AM By: RIEDER, AUSTIN

PROJECT LOCATION

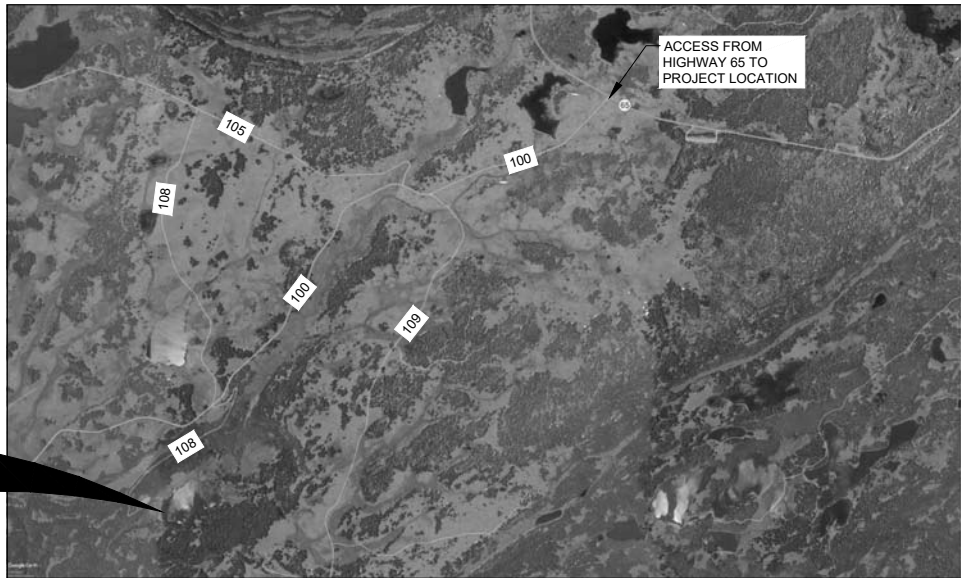

INSET MAP
NOT TO SCALE

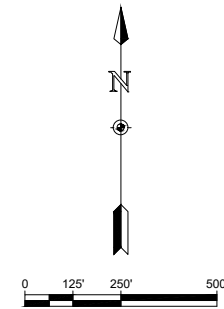

NOTES:

xx

ONE INCH - IF NOT,
SCALE ACCORDINGLY

3665 JFK Parkway
Building 2, Suite 100
Fort Collins, CO 80525
(970) 223-3556



**SITE ACCESS AND
BORROW AREAS PLAN**

**HOGCHUTE DAM REPAIRS
CITY OF GRAND JUNCTION
MESA COUNTY, COLORADO**

Revisions	Date

Project Mgr. CTG	
Designed By: AUS	
Drawn By: RBK	
Approved By: DAM	
Date: 09/29/20	

PROJECT NO.

26-1144.00

DRAWING NO.

G03

Drawing Name: I:\36\26-114400 GRAND JUNCTION HOGCHUTE DAM\MAINDWGS 2020\SHEETS\C09 DAM PLAN.DWG Wednesday, January 27, 2021 6:50 AM By: RIEDER, AUSTIN

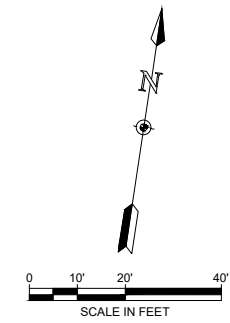
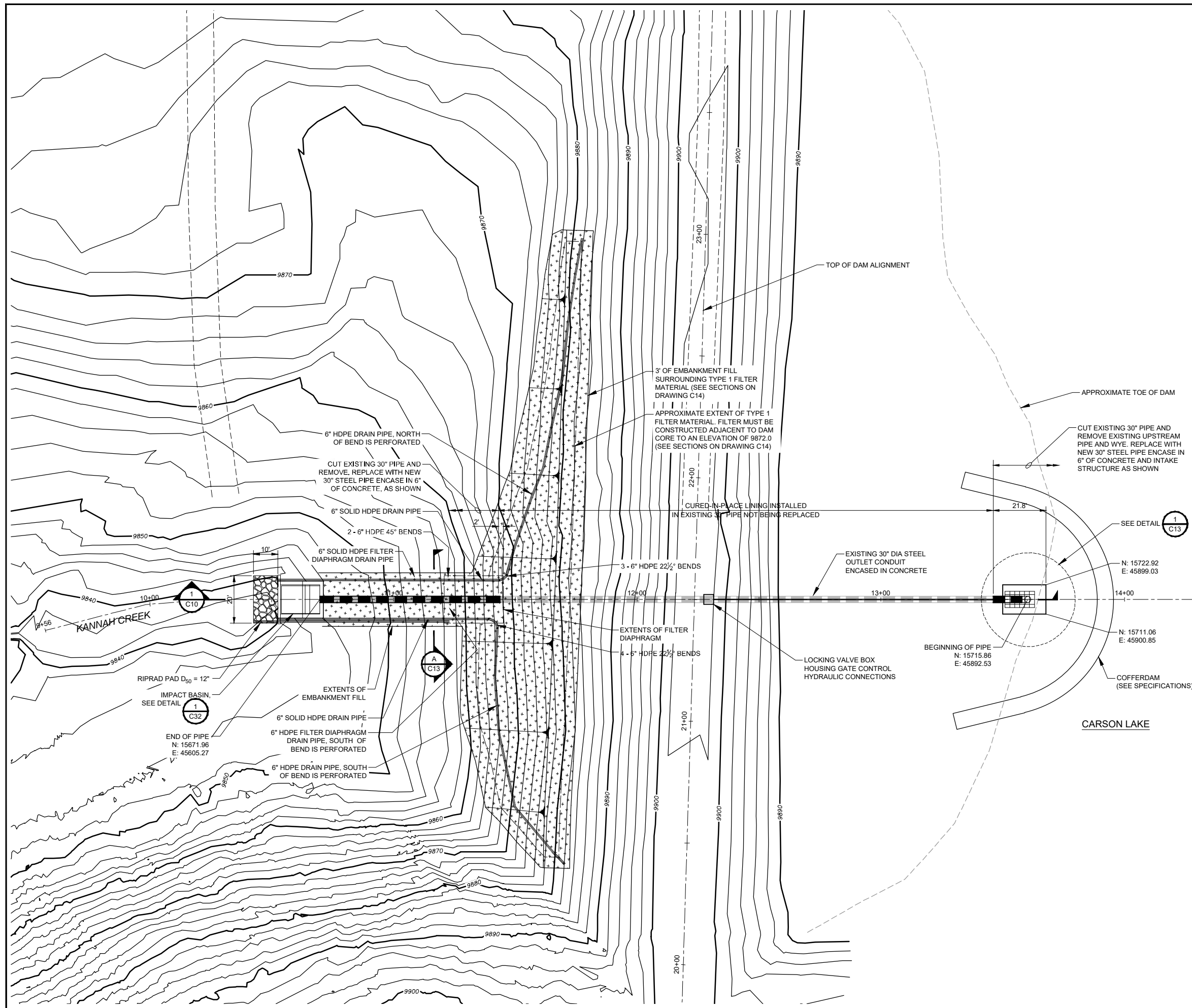

NOTES:

N/A

ONE INCH - IF NOT, SCALE ACCORDINGLY

3665 JFK Parkway
Building 2, Suite 100
Fort Collins, CO 80525
(970) 223-3556

AVRES

XXX

**HOGCHUTE DAM REPAIRS
CITY OF GRAND JUNCTION PROPOSED CONDITIONS AND COFFERDAM
MESA COUNTY, COLORADO**

Revisions	Date
NOT FOR CONSTRUCTION	JAN 2021

Project Mgr. - CTG	Designed By: AUS	Drawn By: RBR	Approved By: DAM
			Date: 05/29/20

PROJECT NO. 26-1144.00
DRAWING NO. C09
SHEET XX OF 21

Drawing Name: I:\36\26-114400 GRAND JUNCTION HOGCHUTE DAM MAINDWGS 2020\SHEETS\C10 DAM PROFILE AND DETAIL.DWG Wednesday, January 27, 2021 7:43 AM By: RIEDER, AUSTIN

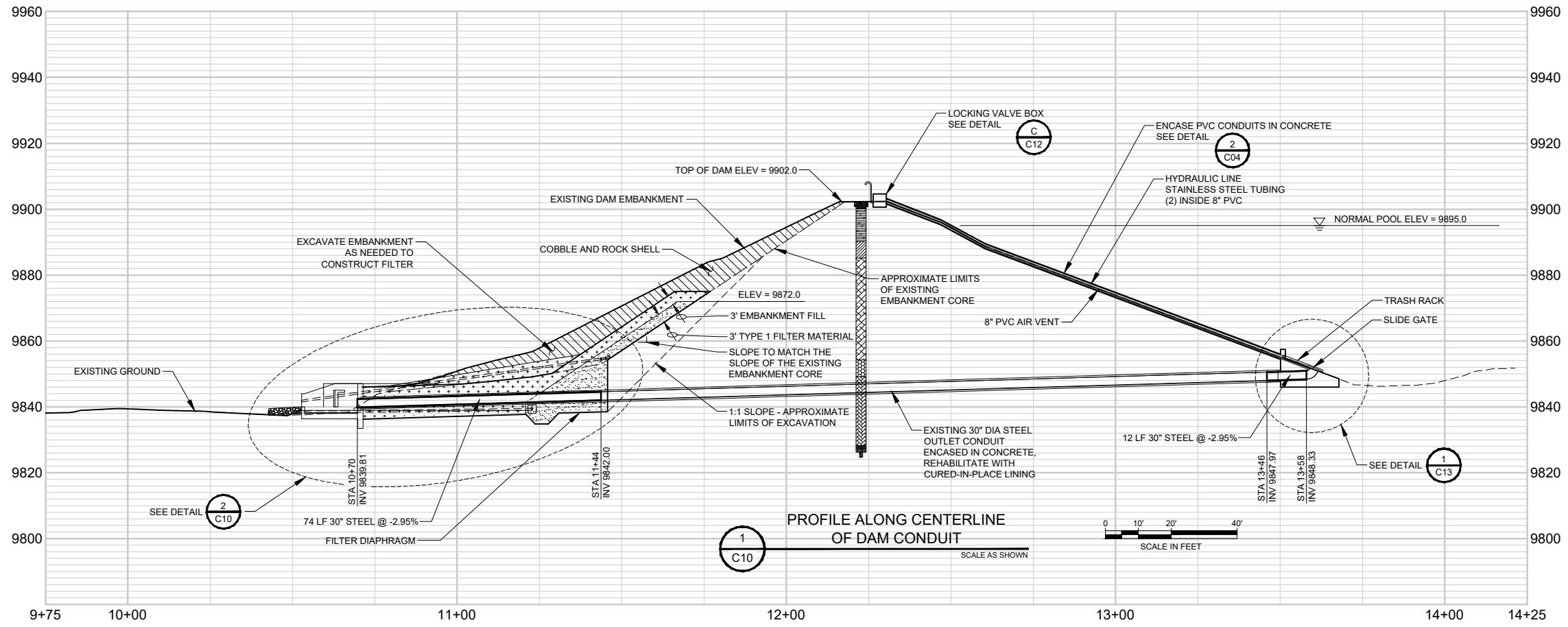

1
C10
PROFILE ALONG CENTERLINE OF DAM CONDUIT
SCALE AS SHOWN

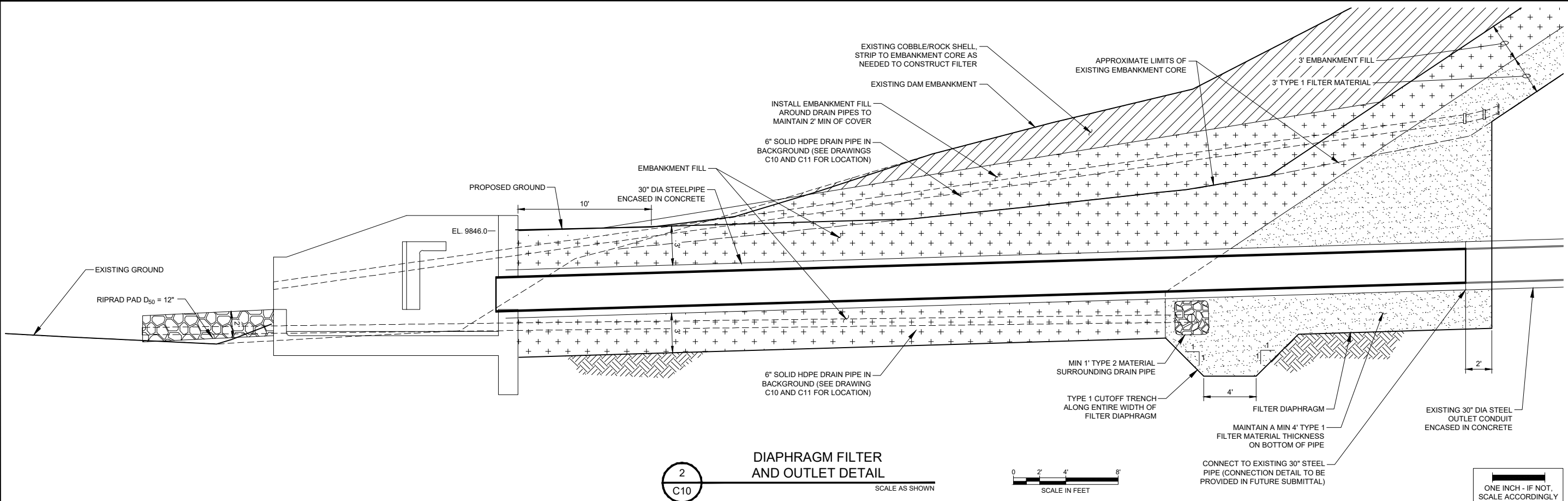
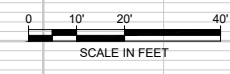

2
C10
DIAPHRAGM FILTER AND OUTLET DETAIL
SCALE AS SHOWN



ONE INCH - IF NOT, SCALE ACCORDINGLY

Project Mgr.:	CTG	Date:	JAN 2021
Designed By:	AJS	Revisions:	NOT FOR CONSTRUCTION
Drawn By:	RBR		
Approved By:	DAM		
Date:	09/29/20		
PROJECT NO.:	26-1144.00		
DRAWING NO.:	C10		
SHEET 7 OF 21			

Drawing Name: I:\36\26-114400 GRAND JUNCTION HOGCHUTE DAM\MAINDWGS 2020\SHEETS\C12 DAM DETAILS 1 OF 2.DWG Wednesday, January 27, 2021 7:51 AM By: RIEDER, AUSTIN

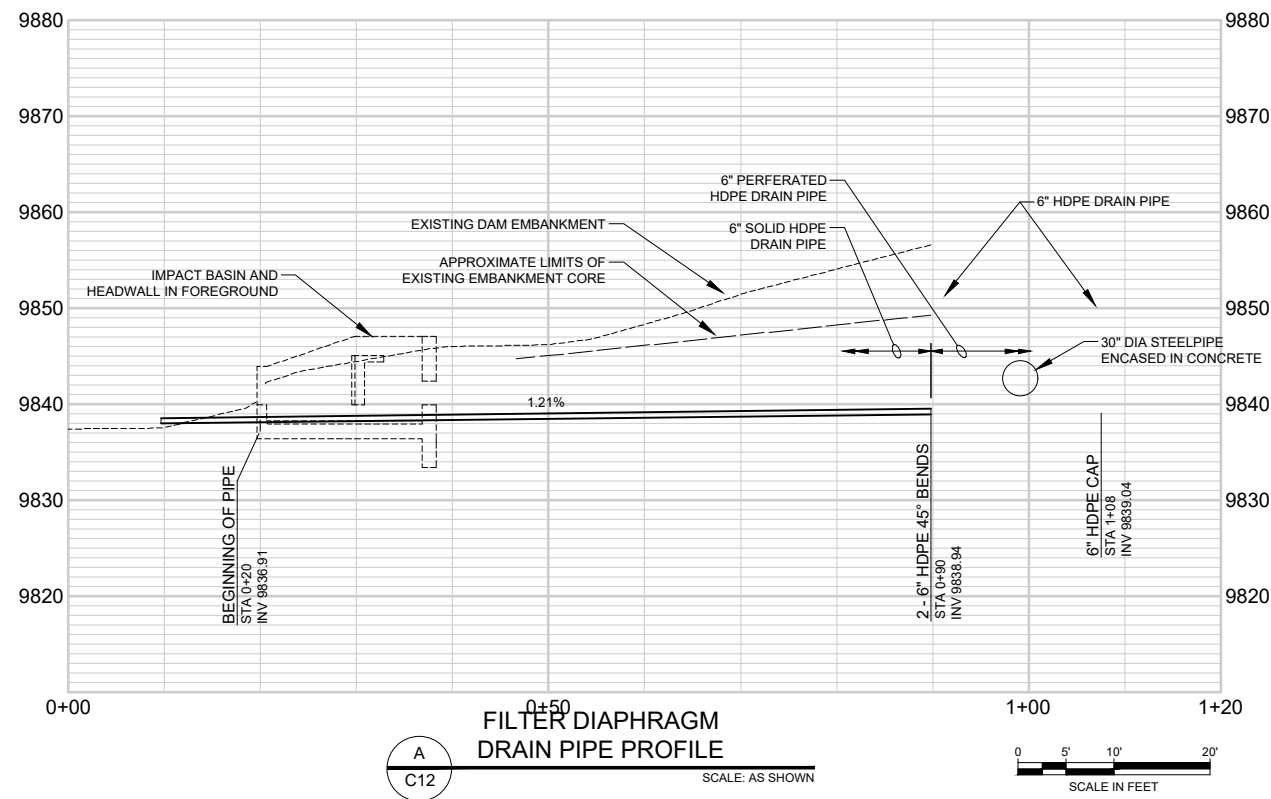

A
C12
SCALE: AS SHOWN

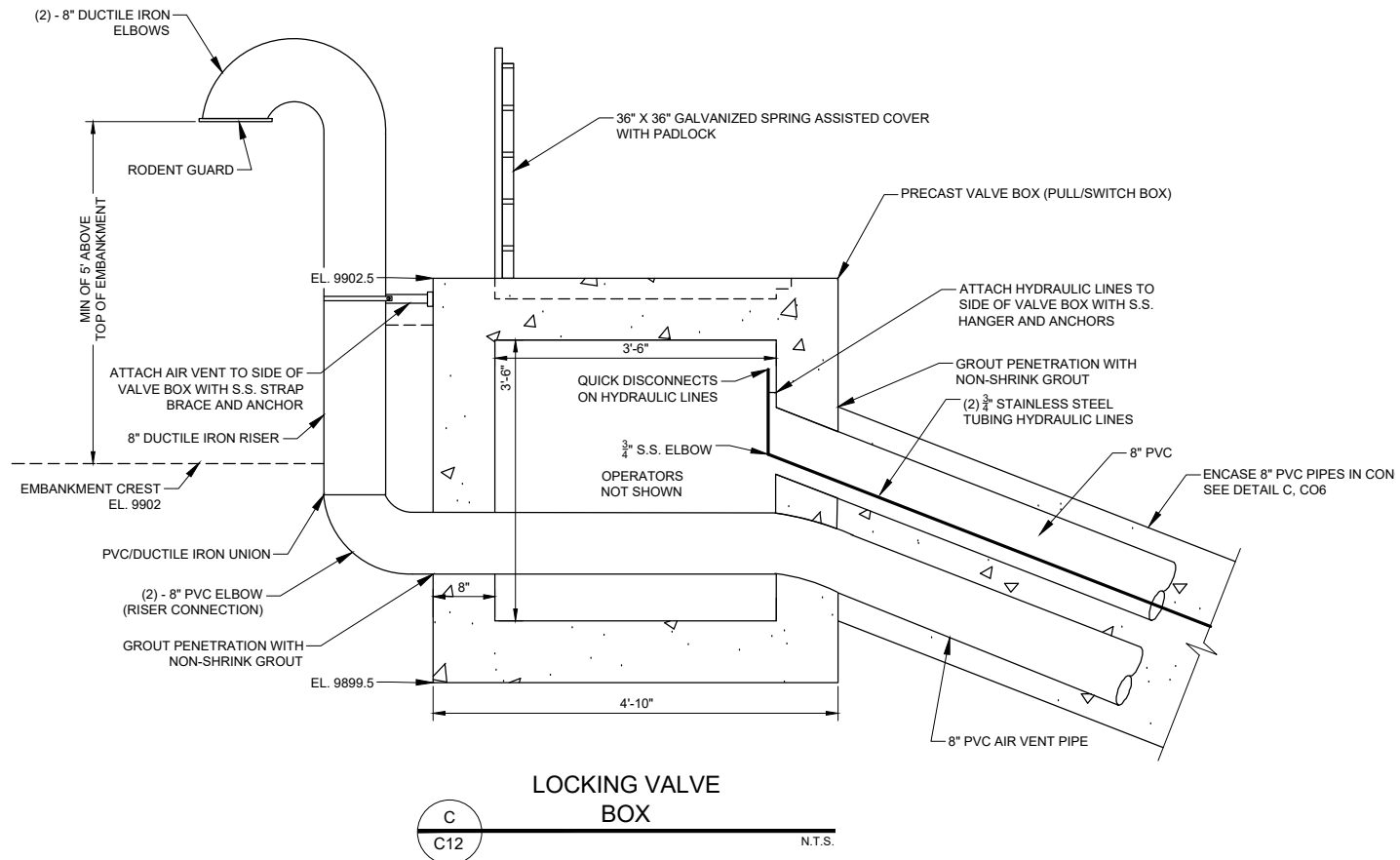

C
C12
N.T.S.

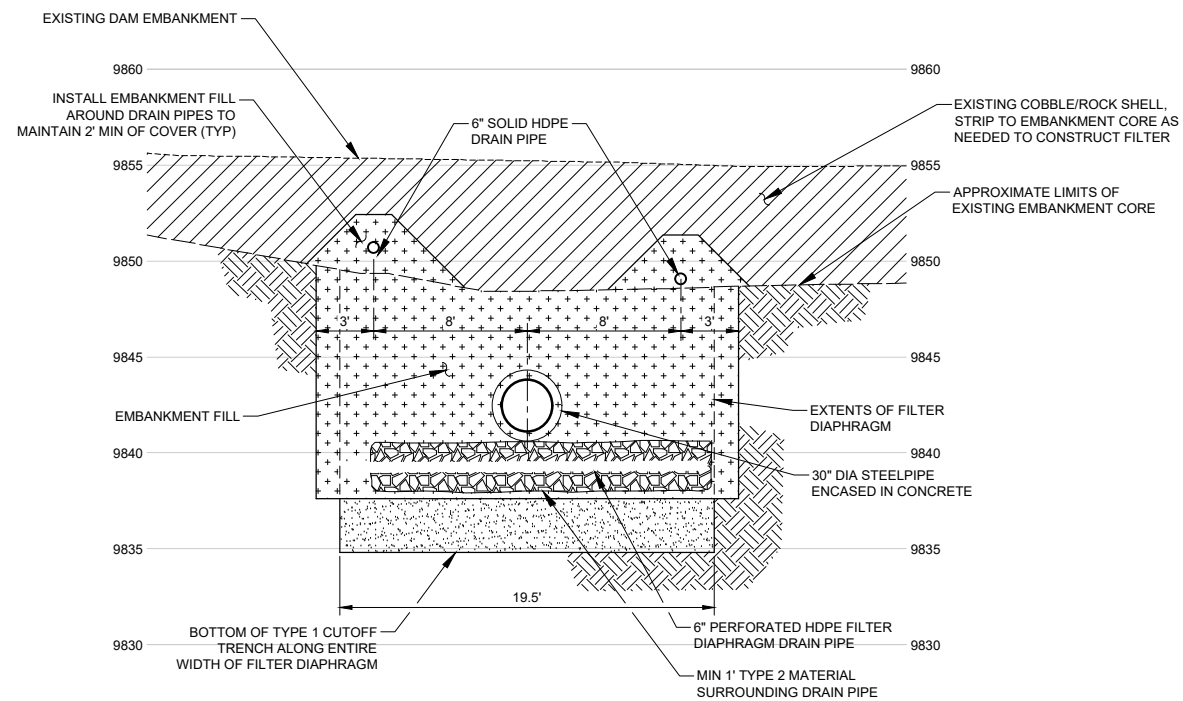

B
C12
SCALE: AS SHOWN

ONE INCH - IF NOT,
SCALE ACCORDINGLY

Project Mgr.	CTG	Date	JAN 2021
Designed By:	AJS	Revisions	NOT FOR CONSTRUCTION
Drawn By:	RBR		
Approved By:	DAM		
Date:	09/29/20		

Drawing Name: I:\36\26-114400 GRAND JUNCTION HOGCHUTE DAM\MAINDWGS 2020\SHEETS\C32 IMPACT BASIN DETAILS.DWG Wednesday, January 27, 2021 7:54 AM By: RIEDER, AUSTIN

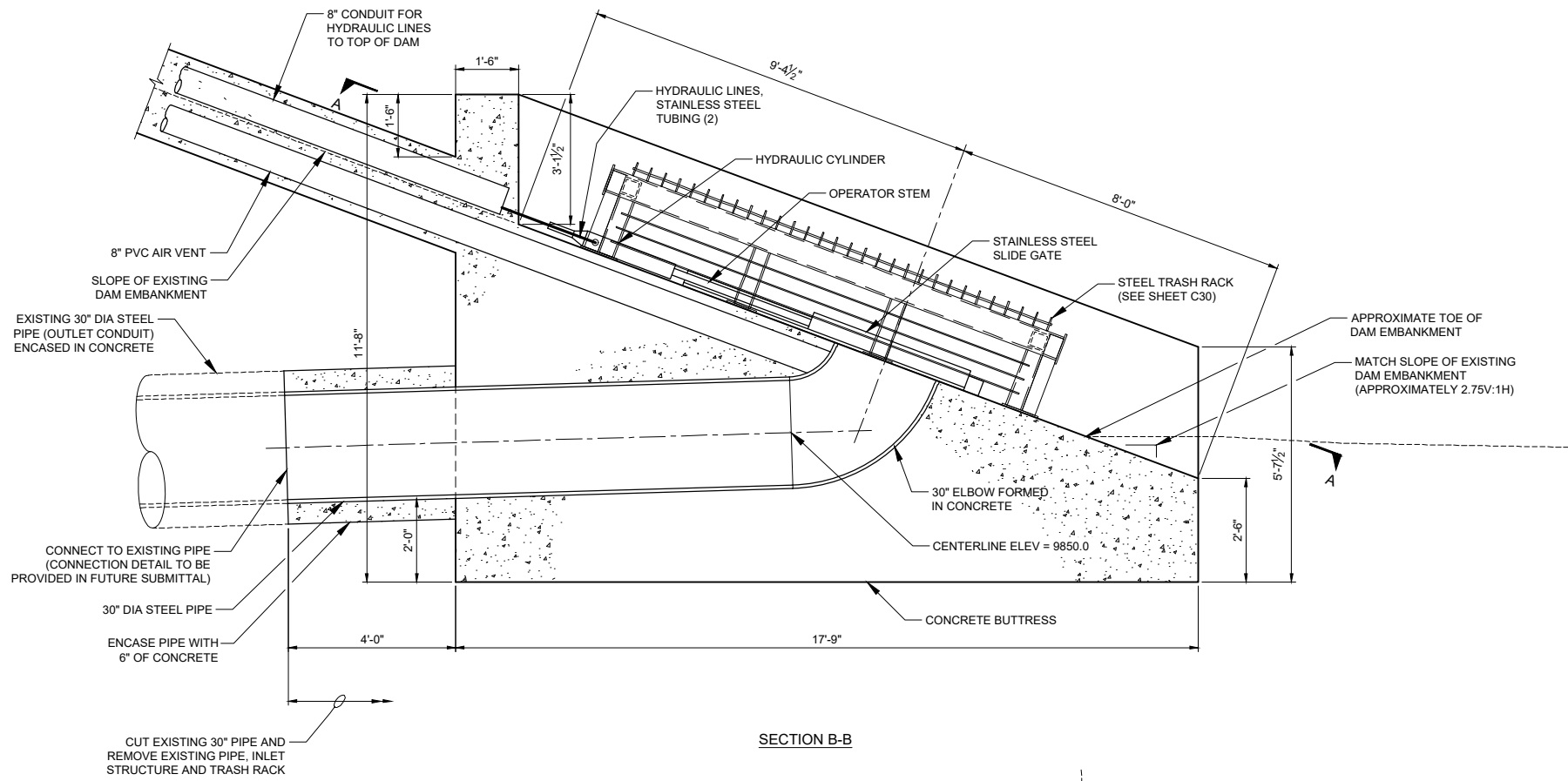

SECTION B-B

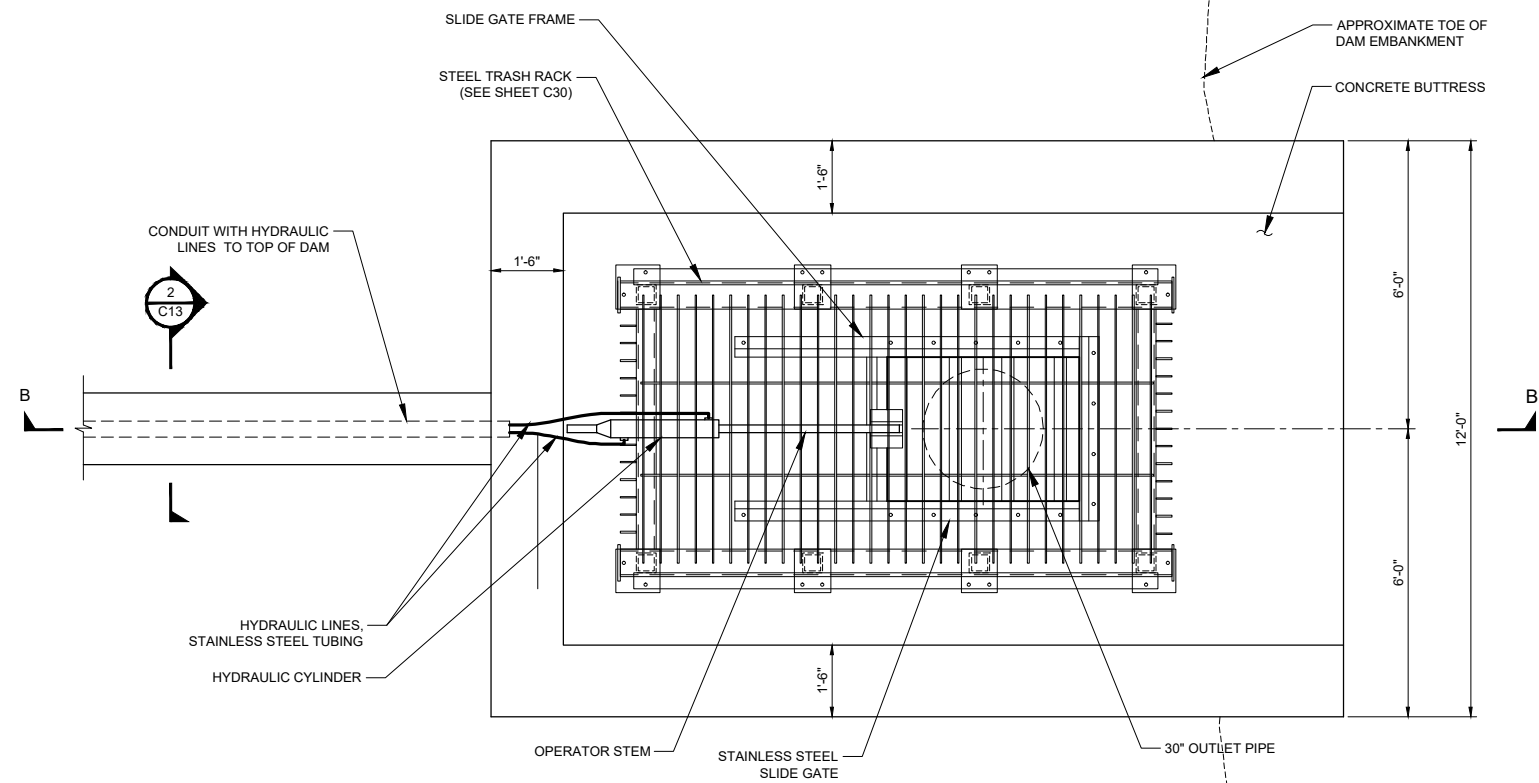

PLAN A-A

NOTES:
 1. CONCRETE REINFORCEMENT NOT SHOWN (SEE SHEET C28)

1
 C13 CONCRETE BUTTRESS DETAIL
 SCALE: 1/2"=1'-0"

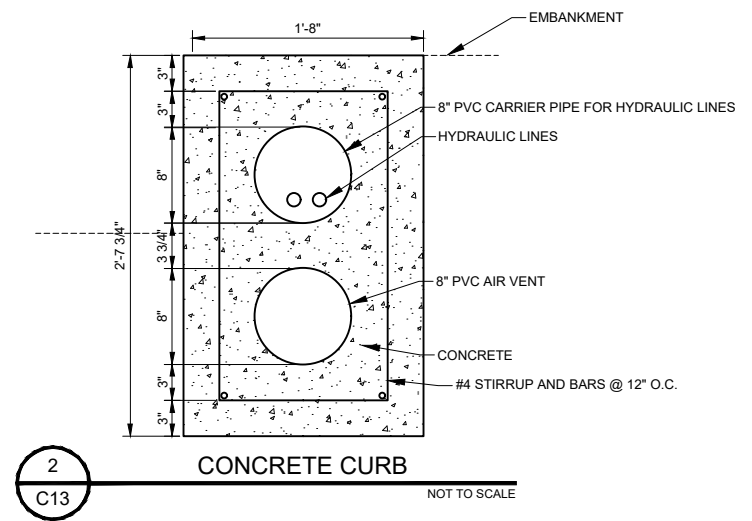

2
 C13 CONCRETE CURB
 NOT TO SCALE

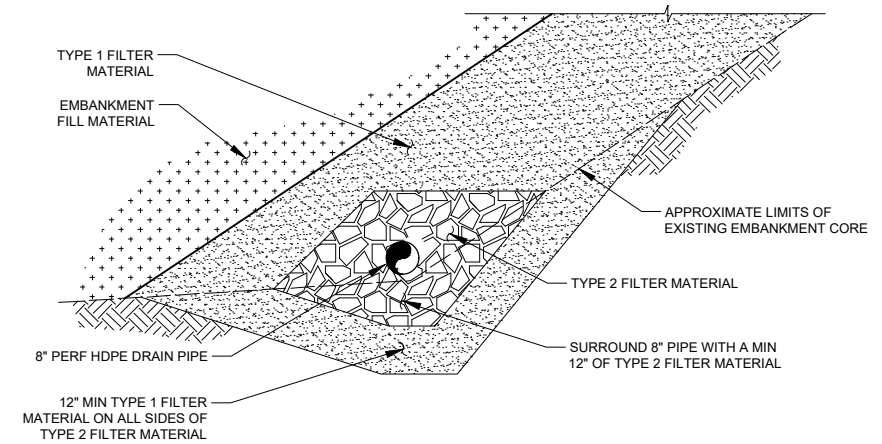

3
 C13 PERFORATED DRAIN PIPE TRENCH DETAIL
 SCALE: 1"=2'

ONE INCH - IF NOT, SCALE ACCORDINGLY

Revisions	Date
NOT FOR CONSTRUCTION	JAN 2021

Project Mgr. CTG	Designed By: AUS
Drawn By: RBR	Approved By: DAM
Date: 05/29/20	

PROJECT NO. 26-1144.00
 DRAWING NO. C13

Drawing Name: I:\36\26-114400 GRAND JUNCTION HOGCHUTE DAM\MAINDWGS 2020\SHEETS\C32 IMPACT BASIN DETAILS.DWG Wednesday, January 27, 2021 7:54 AM By: RIEDER, AUSTIN

NOTES:
1) 4" COVER UNLESS NOTED

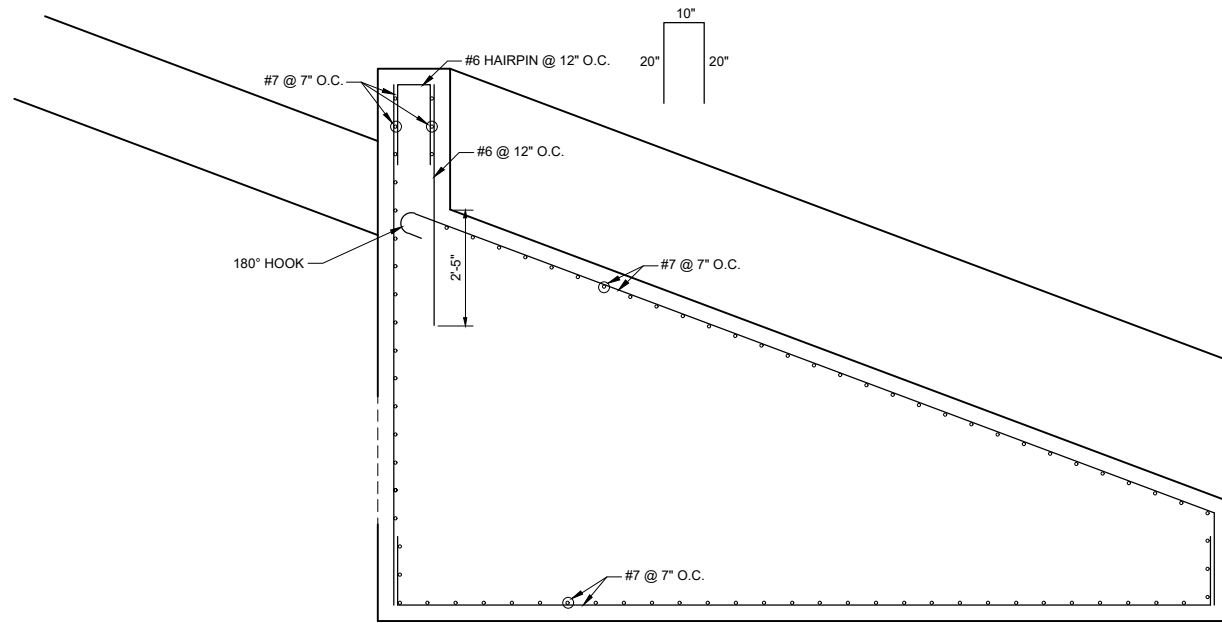

1 CONCRETE HEAD WALL PLAN VIEW
C28 SCALE: 1/2"=1'-0"

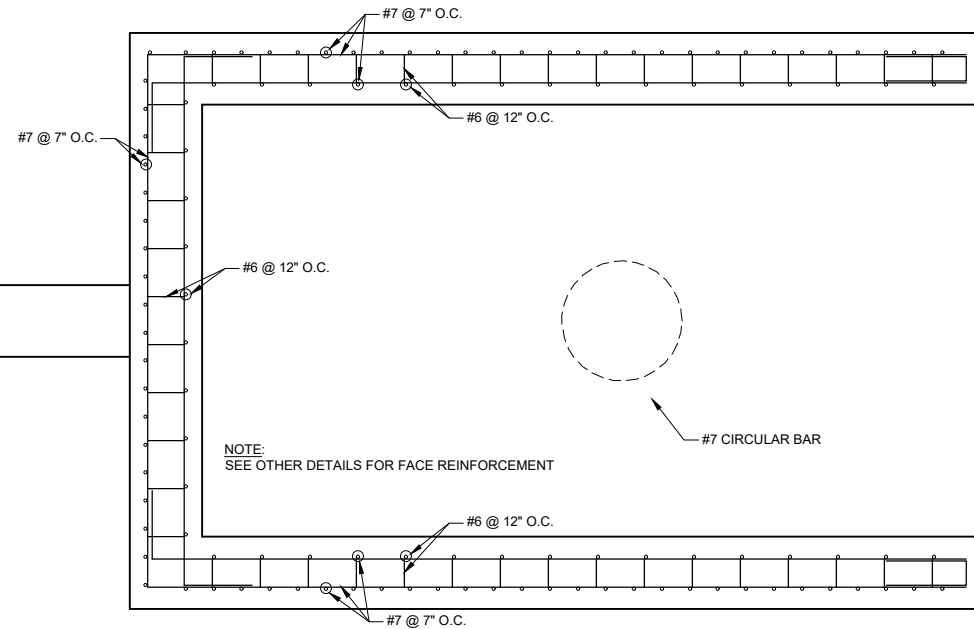

2 CONCRETE HEADWALL DETAIL
C28 SCALE: 1/2"=1'-0"

ONE INCH - IF NOT,
SCALE ACCORDINGLY

AVRES
3665 JFK Parkway
Building 2, Suite 100
Fort Collins, CO 80525
(970) 223-3556

CONCRETE REINFORCEMENT

HOGCHUTE DAM REPAIRS
CITY OF GRAND JUNCTION
MESA COUNTY, COLORADO

Revisions	Date
NOT FOR CONSTRUCTION	JAN 2021

Project Mgr. CTG	Designed By: AUS
Drawn By: RBR	Approved By: DAM
Date: 09/29/20	

PROJECT NO.
26-1144.00
DRAWING NO.
C28
SHEET XX OF 21

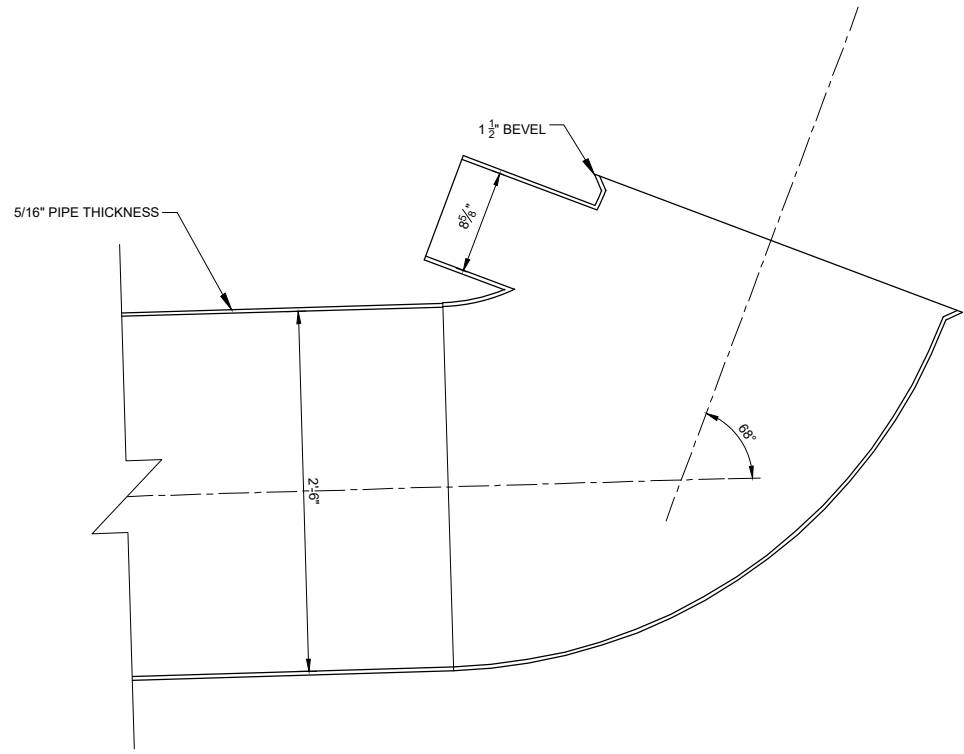

1
C29 **STEEL ELBOW DETAIL**
SCALE: 1"=1'-0"

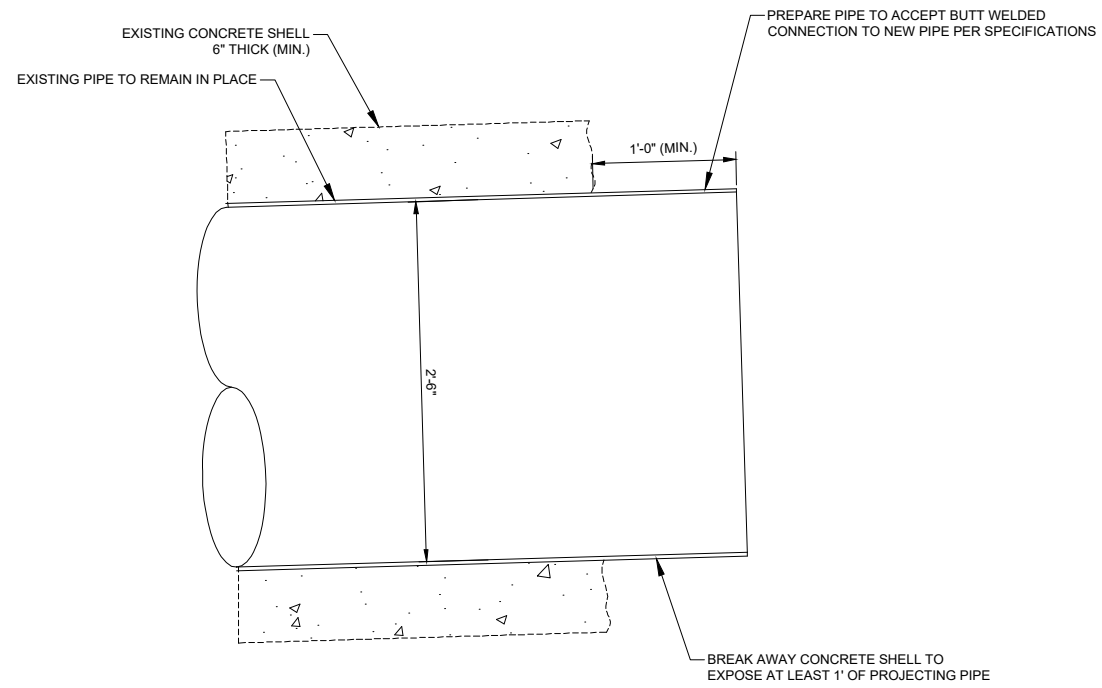

2
C29 **STEEL PIPE CONNECTION DETAIL**
SCALE: 1"=1'-0"

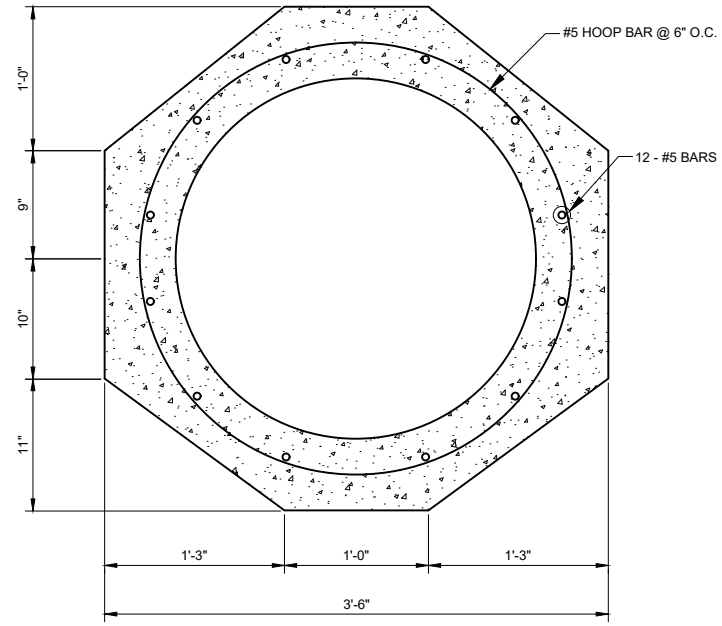

3
C29 **STEEL PIPE ENCASEMENT DETAIL**
SCALE: 1"=1'-0"

ONE INCH - IF NOT,
SCALE ACCORDINGLY

Revisions	Date
NOT FOR CONSTRUCTION	JAN 2021

PROJECT NO.
26-1144.00
DRAWING NO.
C29

Drawing Name: I:\36\26-114400 GRAND JUNCTION HOGCHUTE DAM\MAINDWGS 2020\SHEETS\C32 IMPACT BASIN DETAILS.DWG Wednesday, January 27, 2021 7:54 AM By: RIEDER, AUSTIN

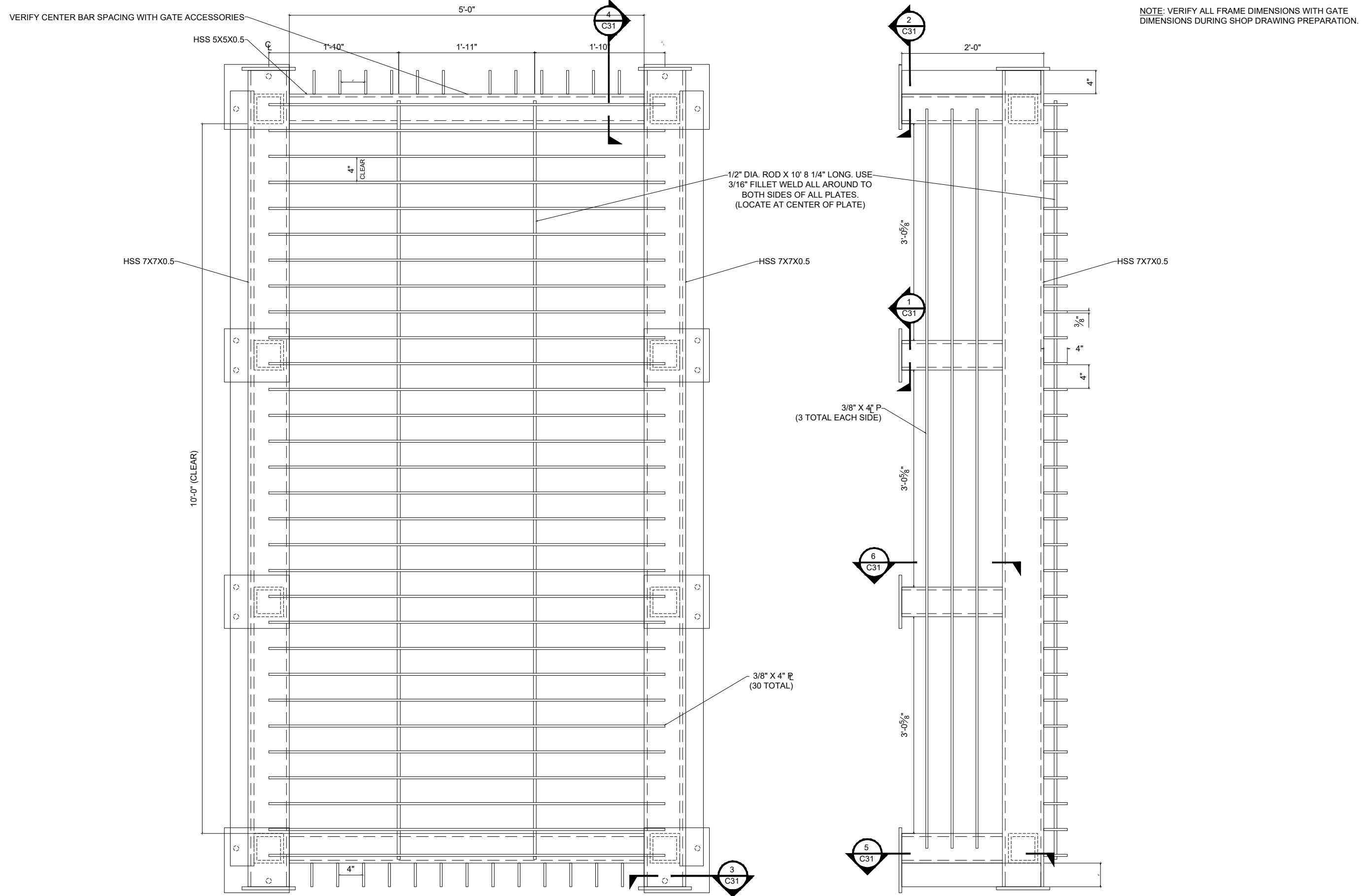

NOTE: VERIFY ALL FRAME DIMENSIONS WITH GATE DIMENSIONS DURING SHOP DRAWING PREPARATION.

1
C13 **SLIDE GATE TRASH RACK**
SCALE: 1 1/2"=1'-0"

ONE INCH - IF NOT, SCALE ACCORDINGLY

3665 JFK Parkway
Building 2, Suite 100
Fort Collins, CO 80525
(970) 223-3556



TRASH RACK DETAILS

HOGCHUTE DAM REPAIRS
CITY OF GRAND JUNCTION
MESA COUNTY, COLORADO

Revisions	Date
NOT FOR CONSTRUCTION	JAN 2021

Project Mgr. CTG	Designed By: AUS
Drawn By: RBR	Approved By: DAM
Date: 09/29/20	

PROJECT NO. 26-1144.00
DRAWING NO. C30

NOTE: VERIFY ALL FRAME DIMENSIONS WITH GATE DIMENSIONS DURING SHOP DRAWING PREPARATION.

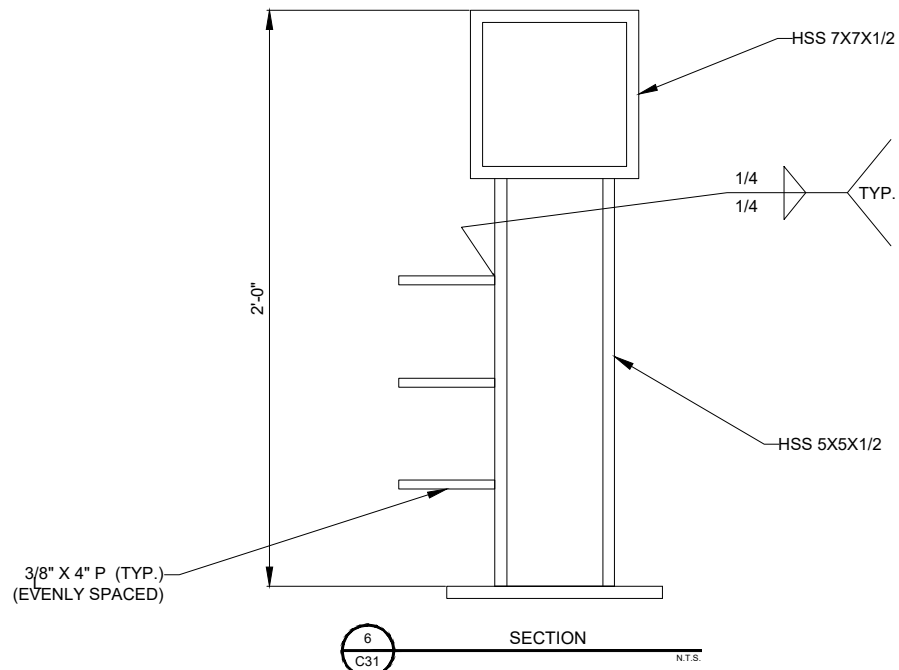
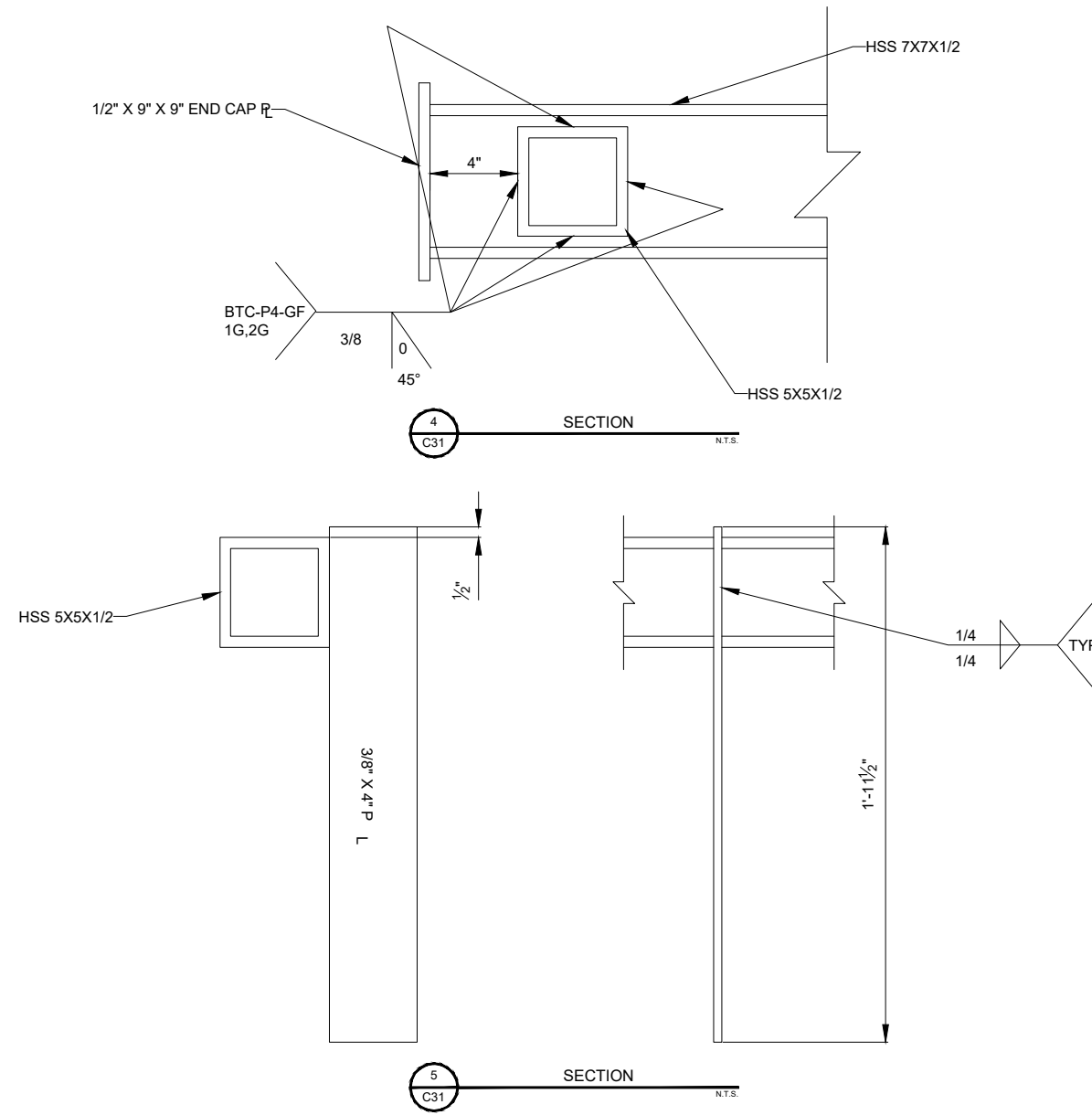
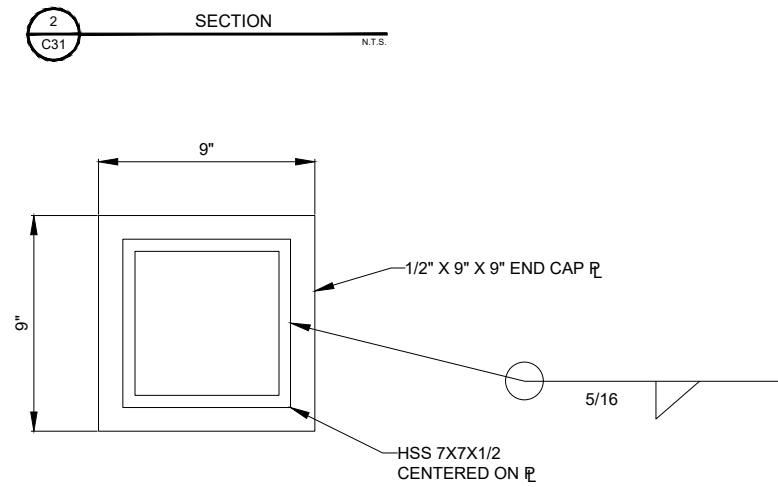
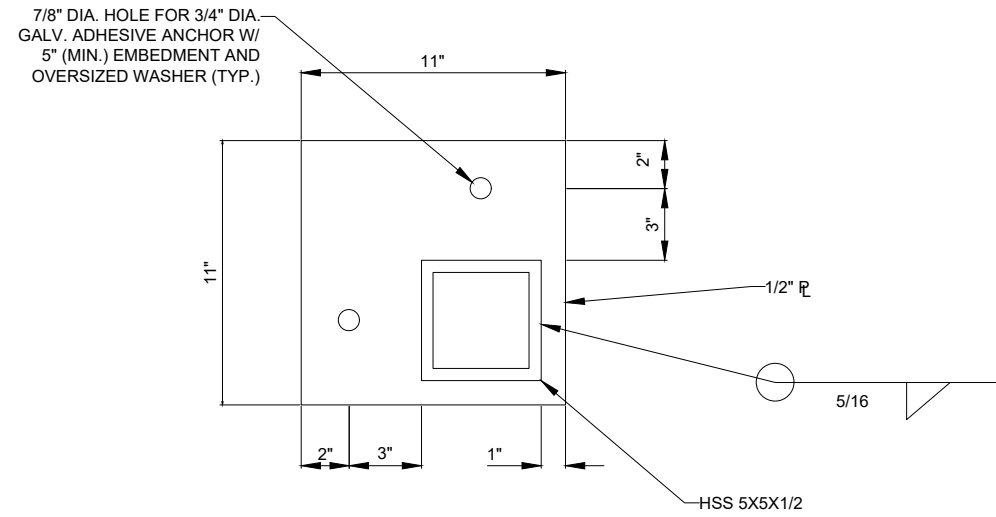
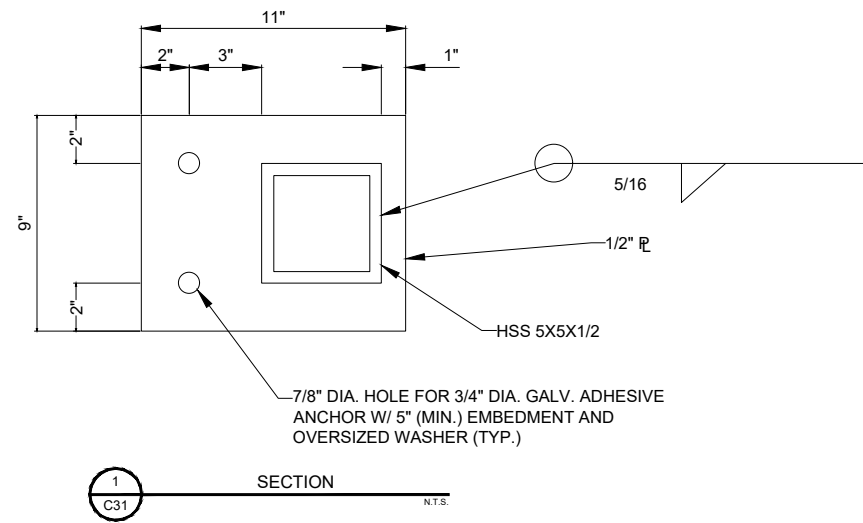

ONE INCH - IF NOT, SCALE ACCORDINGLY

Drawing Name: I:\36\26-114400 GRAND JUNCTION HOGCHUTE DAM\MAINDWGS 2020\SHEETS\C32 IMPACT BASIN DETAILS.DWG Wednesday, January 27, 2021 7:54 AM By: RIEDER, AUSTIN

3665 JFK Parkway
Building 2, Suite 100
Fort Collins, CO 80525
(970) 223-3556

AVRES

TRASH RACK DETAILS

HOGCHUTE DAM REPAIRS
CITY OF GRAND JUNCTION
MESA COUNTY, COLORADO

Revisions	Date
NOT FOR CONSTRUCTION	JAN 2021

Project Mgr. CTG	Designed By: AUS	Drawn By: RBR	Approved By: DAM	Date: 05/29/20
------------------	------------------	---------------	------------------	----------------

PROJECT NO. 26-1144.00
DRAWING NO. C31

SHEET XX OF 21