



NOTICE TO PROCEED

Date: March 8, 2021
Contractor: Dirtworks Construction, LLC
Project: 2021 G Road Irrigation Modification Project IFB-4870-21-DH

In accordance with the contract dated February 26, 2021 the Contractor is hereby notified to begin work on the Project on or before March 9, 2021.

The date of final completion as determined is 45 calendar days from the start date of this Notice to Proceed.

CITY OF GRAND JUNCTION, COLORADO

DocuSigned by:
Duane Hoff Jr., Senior Buyer - City of Grand Junction
9F799E7956F44B6...
Duane Hoff Jr., Senior Buyer

Receipt of this Notice to Proceed is hereby acknowledged:

Contractor: Dirtworks Construction, LLC

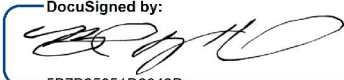
By: 
5B7B23651D2043D...

Print Name: Branden D. Hughes, Owner - Dirtworks Construction, LLC

Title: President/Owner

Date: 3/8/2021 | 11:00 PST



NOTICE OF AWARD

Date: February 26, 2021
Company: Dirtworks Construction, LLC
Project: 2021 G Road Irrigation Modification Project IFB-4870-21-DH

You have been awarded the City of Grand Junction 2021 G Road Irrigation Modification Project IFB-4870-21-DH for a total price of **\$121,496.20**.

Please notify Lee Cooper, City of Grand Junction Project Engineer 970-256-4155 for project scheduling, and return to the City Purchasing Division an acknowledged copy of this Notice of Award, signed Contract, Payment & Performance Bonds, and Insurance Certificate, as per the contract documents.

CITY OF GRAND JUNCTION, COLORADO

DocuSigned by:
Duane Hoff Jr., Senior Buyer - City of Grand Junction
9F709E7D50F41DC...
Duane Hoff Jr., Senior Buyer

SUPPLIER ACKNOWLEDGEMENT

Receipt of this Notice to Award is hereby acknowledged:

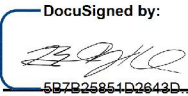
Company: Dirtworks Construction, LLC
By:  Branden
Title: Owner
Date: 2/26/2021 | 08:23 PST



CITY OF GRAND JUNCTION, COLORADO

CONTRACT

This CONTRACT made and entered into this 26th day of February, 2021 by and between the City of Grand Junction, Colorado, a government entity in the County of Mesa, State of Colorado, hereinafter in the Contract Documents referred to as the "Owner" and Dirtworks Construction, LLC hereinafter in the Contract Documents referred to as the "Contractor."

WITNESSETH:

WHEREAS, the Owner advertised that sealed Bids would be received for furnishing all labor, tools, supplies, equipment, materials, and everything necessary and required for the Project described by the Contract Documents and known as 2021 G Road Irrigation Modification Project IFB-4870-21-DH.

WHEREAS, the Contract has been awarded to the above named Contractor by the Owner, and said Contractor is now ready, willing and able to perform the Work specified in accordance with the Contract Documents;

NOW, THEREFORE, in consideration of the compensation to be paid the Contractor, the mutual covenants hereinafter set forth and subject to the terms hereinafter stated, it is mutually covenanted and agreed as follows:

ARTICLE 1

Contract Documents: It is agreed by the parties hereto that the following list of instruments, drawings, and documents which are attached hereto, bound herewith, or incorporated herein by reference constitute and shall be referred to either as the "Contract Documents" or the "Contract", and all of said instruments, drawings, and documents taken together as a whole constitute the Contract between the parties hereto, and they are fully a part of this agreement as if they were set out verbatim and in full herein:

The order of contract document governance shall be as follows:

- a. The body of this contract agreement
- b. Solicitation Documents for the Project; **2021 G Road Irrigation Modification Project**;
- c. Notice of Award
- d. Contractors Response to the Solicitation

- e. Work Change Requests (directing that changed work be performed);
- f. Field Orders
- g. Change Orders.

ARTICLE 2

Definitions: The clauses provided in the Solicitation apply to the terms used in the Contract and all the Contract Documents.

ARTICLE 3

Contract Work: The Contractor agrees to furnish all labor, tools, supplies, equipment, materials, and all that is necessary and required to complete the tasks associated with the Work described, set forth, shown, and included in the Contract Documents as indicated in the Solicitation Document.

ARTICLE 4

Contract Time and Liquidated Damages: Time is of the essence with respect to this Contract. The Contractor hereby agrees to commence Work under the Contract on or before the date specified in the Solicitation from the Owner, and to achieve Substantial Completion and Final Completion of the Work within the time or times specified in the Solicitation. In the event the Work is not completed in the times set forth and as agreed upon, the Contractor further agrees to pay Liquidated Damages to the Owner as set forth in the Solicitation. The Contractor acknowledges and recognizes the delays, expenses and difficulties involved in proving in a legal proceeding the actual losses suffered by the Owner if the work is not completed on time. Accordingly, instead of requiring any such proof, the Owner and the Contractor agree that as Liquidated Damages for delay, but not as a penalty, the Contractor shall pay to the Owner the amounts specified in the Solicitation.

ARTICLE 5

Contract Price and Payment Procedures: The Contractor shall accept as full and complete compensation for the performance and completion of all of the Work specified in the Contract Documents, the sum of **(this amount is corrected for errors form the original bid amount submitted) One Hundred Twenty-One Thousand Four Hundred Ninety-Six and 0/100 Dollars (\$121,496.20)**. If this Contract contains unit price pay items, the Contract Price shall be adjusted in accordance with the actual quantities of items completed and accepted by the Owner at the unit prices quoted in the Solicitation Response. The amount of the Contract Price is and has heretofore been appropriated by the Grand Junction City Council for the use and benefit of this Project. The Contract Price shall not be modified except by Change Order or other written directive of the Owner. The Owner shall not issue a Change Order or other written directive which requires additional work to be performed, which work causes the aggregate amount payable under this Contract to exceed the amount appropriated for this Project, unless and until the Owner provides Contractor written assurance that lawful appropriations to cover the costs of the additional work have been made.

Unless otherwise provided in the Solicitation, monthly partial payments shall be made as the Work progresses. Applications for partial and Final Payment shall be prepared by the Contractor and approved by the Owner in accordance with the Solicitation.

Upon Final Completion of the Work under the Contract and before the Contractor shall receive final payment, the Owner shall publish at least twice in a newspaper of general circulation published in the County a notice that: 1. the Owner has accepted such Work as completed according to the Contract Documents; 2. the Contractor is entitled to final payment therefore; 3. thirty days after the first publication, specifying the exact date, the Owner shall pay the full balance due under the Contract; and 4. persons having claims for labor, materials, team hire, sustenance, provisions, provender, or other supplies used or consumed by the Contractor or a subcontractor shall file a verified statement of the amount due and unpaid on account of such claim prior to the date specified for such payment. Nothing herein shall be construed as relieving the Contractor and the Sureties on the Contractor's Bonds from any claim or claims for work or labor done or materials or supplies furnished in the execution of the Contract.

ARTICLE 6

Bonds: The Contractor shall furnish currently herewith the Bonds required by the Contract Documents, such Bonds being attached hereto. The Performance Bond shall be in an amount not less than one hundred percent (100%) of the Contract Price set forth in Article 5. The Payment Bond shall be in an amount not less than one hundred (100%) of the Contract Price set forth in Article 5.

ARTICLE 7

Contract Binding: The Owner and the Contractor each binds itself, its partners, successors, assigns and legal representatives to the other party hereto in respect to all covenants, agreements and obligations contained in the Contract Documents. The Contract Documents constitute the entire agreement between the Owner and Contractor and may only be altered, amended or repealed by a duly executed written instrument. Neither the Owner nor the Contractor shall, without the prior written consent of the other, assign or sublet in whole or in part its interest under any of the Contract Documents and specifically, the Contractor shall not assign any moneys due or to become due without the prior written consent of the Owner.

ARTICLE 8

Severability: If any part, portion or provision of the Contract shall be found or declared null, void or unenforceable for any reason whatsoever by any court of competent jurisdiction or any governmental agency having the authority thereover, only such part, portion or provision shall be effected thereby and all other parts, portions and provisions of the Contract shall remain in full force and effect.

IN WITNESS WHEREOF, City of Grand Junction, Colorado, has caused this Contract to be subscribed and sealed and attested in its behalf; and the Contractor has signed this Contract the day and the year first mentioned herein.

The Contract is executed in two counterparts.

CITY OF GRAND JUNCTION, COLORADO

DocuSigned by:
By: Duane Hoff Jr., Senior Buyer - City of Grand Junction 2/26/2021 | 09:26 MST
9F789E7D50F14BC...
Duane Hoff Jr., Senior Buyer _____ Date _____

Dirtworks Construction, LLC

DocuSigned by:
By: [Signature] 2/26/2021 | 08:23 PST
5B7D25951D2643D...
Branden _____ Owner _____ Date _____



Purchasing Division

Invitation for Bid

**IFB-4870-21-DH
2021 G Road Irrigation Modification Project**

Responses Due:

February 19, 2021 prior to 3:00 pm

**Accepting Electronic Responses Only
Responses Only Submitted Through the Rocky Mountain E-Purchasing
System (RMEPS)**

<https://www.rockymountainbidsystem.com/default.asp>

(Purchasing Representative does not have access or control of the vendor side of RMEPS. If website or other problems arise during response submission, vendor MUST contact RMEPS to resolve issue prior to the response deadline. 800-835-4603)

IMPORTANT NOTICE:

Due to the recent developments with increased COVID-19 cases in Mesa County, public in-person bid openings are temporarily being suspended. Bid openings will still take place on their designated date and time virtually, and bid tabulations will still be posted for public view/access. Once the crisis has passed, public in-person bid openings will resume as normal. Attached is the virtual link and information to attend the bid opening. Public may addend through the link, or via phone.

Purchasing Representative:

**Duane Hoff, Senior Buyer
duaneh@gjcity.org
970-244-1545**

This document has been developed specifically to solicit competitive responses for this solicitation, and may not be the same as previous City of Grand Junction solicitations. All vendors are urged to thoroughly review this solicitation prior to responding. Submittal by **FAX, EMAIL or HARD COPY IS NOT ACCEPTABLE** for this solicitation.

Invitation for Bids

Table of Contents

Section 1	Instruction to Bidders
Section 2	General Contract Conditions
Section 3	Statement of Work
Section 4	Contractor's Bid Form
	Price Proposal/Bid Schedule Form
Appendix A	Project Submittal Form
Appendix B	Project Special Provisions
	Construction Drawings Attached

1. Instructions to Bidders

- 1.1. Purpose:** The City of Grand Junction is soliciting competitive bids from qualified and interested companies for all labor, equipment, and materials required for the **2021 G Road Irrigation Modifications Project**. All dimensions and scope of work should be verified by Contractors prior to submission of bids.

IFB Questions:

Duane Hoff, Senior Buyer

duaneh@gjcity.org

970-244-1545

The City would like to remind all Contractors, Sub-Contractors, Vendors, Suppliers, Manufacturers, Service Providers, etc. that (with the exception of Pre-Bid or Site Visit Meetings) all questions, inquiries, comments, or communication pertaining to any formal solicitation (whether process, specifications, scope, etc.) must be directed (in writing) to the Purchasing Agent assigned to the project, or Purchasing Division. Direct communication with the City assigned Project Managers/Engineers is not appropriate for public procurement, and may result in disqualification.

- 1.2. Mandatory Site Visit Meeting:** **Prospective bidders are required to attend a site visit meeting on February 9, 2021 at 10:30 am.** Meeting location will be at the south end of Canyon View Park on G Road. Park in the diagonal parking spaces along the northside of G Road at Canyon View Park. The purpose of this visit will be to inspect and to clarify the contents of this Invitation for Bids (IFB).
- 1.3. The Owner:** The Owner is the City of Grand Junction, Colorado and is referred to throughout this Solicitation. The term Owner means the Owner or his authorized representative.
- 1.4. Procurement Process:** Procurement processes shall be governed by the most current version of the City of Grand Junction [Purchasing Policy and Procedure Manual](#).
- 1.5. Submission:** **Each bid shall be submitted in electronic format only, and only through the Rocky Mountain E-Purchasing website (<https://www.rockymountainbidsystem.com/default.asp>).** **This site offers both “free” and “paying” registration options that allow for full access of the Owner’s documents and for electronic submission of proposals.** (Note: “free” registration may take up to 24 hours to process. Please Plan accordingly.) Please view our “**Electronic Vendor Registration Guide**” at <http://www.gjcity.org/business-and-economic-development/bids/> for details. (Purchasing Representative does not have access or control of the vendor side of RMEPS. If website or other problems arise during response submission, vendor **MUST** contact RMEPS to resolve issue prior to the response deadline. **800-835-4603**)

Please join Solicitation Opening, IFB-4870-21-DH, 2021 G Road Irrigation Modification Project on GoToConnect from your computer using the Chrome browser.
<https://my.jive.com/meet/905489461>

You can also dial in using your phone.
US: (571) 317-3116

Access Code: 905-489-461

- 1.6. **Modification and Withdrawal of Bids Before Opening.** Bids may be modified or withdrawn by an appropriate document stating such, duly executed and submitted to the place where Bids are to be submitted at any time prior to Bid Opening.
- 1.7. **Printed Form for Price Bid:** All Price Bids must be made upon the Price Bid Schedule attached, and should give the amounts both in words and in figures, and must be signed and acknowledged by the bidder.

The Offeror shall specify a unit price in figures for each pay item for which a quantity is given and shall provide the products (in numbers) of the respective unit prices and quantities in the Extended Amount column. The total Bid price shall be equal to the sum of all extended amount prices. When an item in the Price Bid Schedule provides a choice to be made by the Offeror, Offeror's choice shall be indicated in accordance with the specifications for that particular item and thereafter no further choice shall be permitted.

Where the unit of a pay item is lump sum, the lump sum amount shall be shown in the "extended amount" column and included in the summation of the total Bid.

All blank spaces in the Price Bid Schedule must be properly filled out.

Bids by corporations must be executed in the corporate name by the president or vice president or other corporate office accompanied by evidence of authority to sign. The corporate address and state of incorporation shall be shown below the signature.

Bids by partnerships must be executed in the partnership name and signed by a partner whose title must appear under the signature and the official address of the partnership must be shown below the signature.

All names must be typed or printed below the signature.

The Offeror's Bid shall contain an acknowledgement of receipt of all Addenda, the numbers of which shall be filled in on the Contractor's Bid Form.

The contact information to which communications regarding the Bid are to be directed must be shown.

- 1.8. **Exclusions:** No oral, telephonic, emailed, or facsimile bid will be considered
- 1.9. **Contract Documents:** The complete IFB and bidder's response compose the Contract Documents. Copies of bid documents can be obtained from the City Purchasing website, <http://www.gjcity.org/business-and-economic-development/bids/> .
- 1.10. **Additional Documents:** The July 2010 edition of the "City Standard Contract Documents for Capital Improvements Construction", Plans, Specifications and other Bid

Documents are available for review or download on the Public Works & Planning/Engineering page at www.gjcity.org. Electronic copies may be obtained on a CD format at the Department of Public Works and Planning at City Hall.

- 1.11. Definitions and Terms:** See Article I, Section 3 of the General Contract Conditions in the *Standard Contract Documents for Capital Improvements Construction*.
- 1.12. Examination of Specifications:** Bidders shall thoroughly examine and be familiar with the project Statement of Work. The failure or omission of any Offeror to receive or examine any form, addendum, or other document shall in no way relieve any Offeror from any obligation with respect to his bid. The submission of a bid shall be taken as evidence of compliance with this section. Prior to submitting a bid, each Offeror shall, at a minimum:
- a. Examine the *Contract Documents* thoroughly;
 - b. Visit the site to familiarize themselves with local conditions that may in any manner affect cost, progress, or performance of the Work;
 - c. Become familiar with federal, state, and local laws, ordinances, rules, and regulations that may in any manner affect cost, progress or performance of the Work;
 - d. Study and carefully correlate Bidder's observations with the *Contract Documents*, and;
 - e. Notify the Purchasing Agent of all conflicts, errors, ambiguities or discrepancies in or among the *Contract Documents* within the designated inquiry period.

On request, the Owner will provide each Offeror access to the site to conduct such investigations and tests as each Bidder deems necessary for submission of a Bid. It shall be the Offeror's responsibility to make or obtain any additional examinations, investigations, explorations, tests and studies and obtain any additional information and data which pertain to the physical conditions (including without limitation, surface, subsurface and underground utilities) at or contiguous to the site or otherwise which may affect cost, progress or performance of the work and which the Offeror deems necessary to determine its Bid for performing the work in accordance with the time, price and other terms and conditions of the *Contract Documents*. Location of any excavation or boring made by Offeror shall be subject to prior approval of Owner and applicable agencies. Offeror shall fill all holes, restore all pavements to match the existing structural section and shall clean up and restore the site to its former condition upon completion of such exploration. The Owner reserves the right to require the Offeror to execute an access agreement with the Owner prior to accessing the site.

The lands upon which the Work is to be performed, rights of way, and access thereto, and other lands designated for use by Contractor in performing the Work, are identified on the Drawings.

Information and data reflected in the *Contract Documents* with respect to underground utilities at or contiguous to the site are based upon information and data furnished to the Owner and the Engineer by the owners of such underground utilities or others, and the Owner does not assume responsibility for the accuracy or completeness thereof, unless it is expressly provided otherwise in the *Contract Documents*.

By submission of a Bid, the Offeror shall be conclusively presumed to represent that the Offeror has complied with every requirement of these Instructions to Bidders, that the *Contract Documents* are not ambiguous and are sufficient in scope and detail to indicate and convey understanding of all terms and conditions for performance of the Work.

- 1.13. **Questions Regarding Statement of Work:** Any information relative to interpretation of Scope of Work or specifications shall be requested of the Purchasing Representative, in writing, in ample time, prior to the inquiry deadline.
- 1.14. **Addenda & Interpretations:** If it becomes necessary to revise any part of this solicitation, a written addendum will be posted electronically on the City's website at <http://www.gjcity.org/business-and-economic-development/bids/>. The Owner is not bound by any oral representations, clarifications, or changes made in the written specifications by Owner, unless such clarification or change is provided in written addendum form from the City Purchasing Representative.
- 1.15. **Taxes:** The Owner is exempt from State retail and Federal tax. The bid price must be net, exclusive of taxes.
- 1.16. **Sales and Use Taxes:** The Contractor and all Subcontractors are required to obtain exemption certificates from the Colorado Department of Revenue for sales and use taxes in accordance with the provisions of the General Contract Conditions. Bids shall reflect this method of accounting for sales and use taxes on materials, fixtures and equipment.
- 1.17. **Offers Binding 60 Days:** Unless additional time is required by the Owner, or otherwise specified, all formal offers submitted shall be binding for sixty (60) calendar days following opening date, unless the Bidder, upon request of the Purchasing Representative, agrees to an extension.
- 1.18. **Exceptions and Substitutions:** Bidders taking exception to the specifications and/or scope of work shall do so at their own risk. The Owner reserves the right to accept or reject any or all substitutions or alternatives. When offering substitutions and/or alternatives, Bidder must state these exceptions in the section pertaining to that area. Exception/substitution, if accepted, must meet or exceed the stated intent and/or specifications and/or scope of work. The absence of such a list shall indicate that the Bidder has not taken exceptions, and if awarded a contract, shall hold the Bidder responsible to perform in strict accordance with the specifications and/or scope of work contained herein.
- 1.19. **Collusion Clause:** Each bidder by submitting a bid certifies that it is not party to any collusive action or any action that may be in violation of the Sherman Antitrust Act. Any and all bids shall be rejected if there is evidence or reason for believing that collusion

exists among bidders. The Owner may, or may not, accept future bids for the same services or commodities from participants in such collusion.

- 1.20. Disqualification of Bidders:** A Bid will not be accepted from, nor shall a Contract be awarded to, any person, firm, or corporation that is in arrears to the Owner, upon debt or contract, or that has defaulted, as surety or otherwise, upon any obligation to the Owner, or that is deemed irresponsible or unreliable.

Bidders may be required to submit satisfactory evidence that they are responsible, have a practical knowledge of the project bid upon and that they have the necessary financial and other resources to complete the proposed Work.

Either of the following reasons, without limitation, shall be considered sufficient to disqualify a Bidder and Bid:

- a. More than one Bid is submitted for the same Work from an individual, firm, or corporation under the same or different name; and
- b. Evidence of collusion among Bidders. Any participant in such collusion shall not receive recognition as a Bidder for any future work of the Owner until such participant has been reinstated as a qualified bidder.

- 1.21. Public Disclosure Record:** If the bidder has knowledge of their employee(s) or sub-contractors having an immediate family relationship with a City employee or elected official, the bidder must provide the Purchasing Representative with the name(s) of these individuals. These individuals are required to file an acceptable "Public Disclosure Record", a statement of financial interest, before conducting business with the City.

2. General Contract Conditions for Construction Projects

- 2.1. The Contract:** This Invitation for Bid, submitted documents, and any negotiations, when properly accepted by the City, shall constitute a contract equally binding between the City and Contractor. The contract represents the entire and integrated agreement between the parties hereto and supersedes all prior negotiations, representations, or agreements, either written or oral. The contract may be amended or modified with Change Orders, Field Orders, or Addendums.
- 2.2. The Work:** The term Work includes all labor necessary to produce the construction required by the Contract Documents, and all materials and equipment incorporated or to be incorporated in such construction.
- 2.3. Execution, Correlation, Intent, and Interpretations:** The Contract Documents shall be signed by the Owner (City) and Contractor. City will provide the contract. By executing the contract, the Contractor represents that he/she has visited the site, familiarized himself with the local conditions under which the Work is to be performed, and correlated his observations with the requirements of the Contract Documents. The Contract Documents are complementary, and what is required by any one, shall be as binding as if required by all. The intention of the documents is to include all labor,

materials, equipment and other items necessary for the proper execution and completion of the scope of work as defined in the technical specifications and drawings contained herein. All drawings, specifications and copies furnished by the City are, and shall remain, City property. They are not to be used on any other project, and with the exception of one contract set for each party to the contract, are to be returned to the owner on request at the completion of the work.

- 2.4. The Owner:** The Owner is the City of Grand Junction, Colorado and is referred to throughout the Contract Documents. The term Owner means the Owner or his authorized representative. The Owner shall, at all times, have access to the work wherever it is in preparation and progress. The Contractor shall provide facilities for such access. The Owner will make periodic visits to the site to familiarize himself generally with the progress and quality of work and to determine, in general, if the work is proceeding in accordance with the contract documents. Based on such observations and the Contractor's Application for Payment, the Owner will determine the amounts owing to the Contractor and will issue Certificates for Payment in such amounts, as provided in the contract. The Owner will have authority to reject work which does not conform to the Contract documents. Whenever, in his reasonable opinion, he considers it necessary or advisable to insure the proper implementation of the intent of the Contract Documents, he will have authority to require the Contractor to stop the work or any portion, or to require special inspection or testing of the work, whether or not such work can be then be fabricated, installed, or completed. The Owner will not be responsible for the acts or omissions of the Contractor, and sub-Contractor, or any of their agents or employees, or any other persons performing any of the work.
- 2.5. Contractor:** The Contractor is the person or organization identified as such in the Agreement and is referred to throughout the Contract Documents. The term Contractor means the Contractor or his authorized representative. The Contractor shall carefully study and compare the General Contract Conditions of the Contract, Specification and Drawings, Scope of Work, Addenda and Modifications and shall at once report to the Owner any error, inconsistency or omission he may discover. Contractor shall not be liable to the Owner for any damage resulting from such errors, inconsistencies or omissions. The Contractor shall not commence work without clarifying Drawings, Specifications, or Interpretations.
- 2.6. Sub-Contractors:** A sub-contractor is a person or organization who has a direct contract with the Contractor to perform any of the work at the site. The term sub-contractor is referred to throughout the contract documents and means a sub-contractor or his authorized representative.
- 2.7. Award of Sub-Contractors & Other Contracts for Portions of the Work:** Contractor shall submit with their bid response to the Owner, in writing for acceptance, a list of the names of the sub-contractors or other persons or organizations proposed for such portions of the work as may be designated in the proposal requirements, or, if none is so designated, the names of the sub-contractors proposed for the principal portions of the work. Prior to the award of the contract, the Owner shall notify the successful Contractor in writing if, after due investigation, has reasonable objection to any person or organization on such list. If, prior to the award of the contract, the Owner has a reasonable and substantial objection to any person or organization on such list, and

refuses in writing to accept such person or organization, the successful Contractor may, prior to the award, withdraw their proposal without forfeiture of proposal security. If the successful Contractor submits an acceptable substitute with an increase in the proposed price to cover the difference in cost occasioned by the substitution, the Owner may, at their discretion, accept the increased proposal or may disqualify the Contractor. If, after the award, the Owner refuses to accept any person or organization on such list, the Contractor shall submit an acceptable substitute and the contract sum shall be increased or decreased by the difference in cost occasioned by such substitution and an appropriate Change Order shall be issued. However, no increase in the contract sum shall be allowed for any such substitution unless the Contractor has acted promptly and responsively in submitting a name with respect thereto prior to the award.

- 2.8. Quantities of Work and Unit Price:** Materials or quantities stated as unit price items in the Bid are supplied only to give an indication of the general scope of the Work, and are as such, estimates only. The Owner does not expressly or by implication agree that the actual amount of Work or material will correspond therewith, and reserves the right after award to increase or decrease the quantity of any unit item of the Work without a change in the unit price except as set forth in Article VIII, Section 70 of the *General Contract Conditions*. The City also reserves the right to make changes in the Work (including the right to delete any bid item in its entirety or add additional bid items) as set forth in Article VIII, Sections 69 through 71 of the *General Contract Conditions*.
- 2.9. Substitutions:** The materials, products and equipment described in the *Solicitation Documents* shall be regarded as establishing a standard of required performance, function, dimension, appearance, or quality to be met by any proposed substitution. No substitution will be considered prior to receipt of Bids unless the Offeror submits a written request for approval to the City Purchasing Division at least ten (10) days prior to the date for receipt of Bids. Such requests for approval shall include the name of the material or equipment for which substitution is sought and a complete description of the proposed substitution including drawings, performance and test data, and other information necessary for evaluation, including samples if requested. The Offeror shall set forth changes in other materials, equipment, or other portions of the Work including changes of the work of other contracts, which incorporation of the proposed substitution would require to be included. The Owner's decision of approval or disapproval of a proposed substitution shall be final. If the Owner approves a proposed substitution before receipt of Bids, such approval will be set forth in an Addendum. Offerors shall not rely upon approvals made in any other manner.
- 2.10. Supervision and Construction Procedures:** The Contractor shall supervise and direct the work, using his best skill and attention. He shall be solely responsible for all construction means, methods, techniques, sequences and procedures and for coordinating all portions of the work under the contract.
- 2.11. Warranty:** The Contractor warrants to the Owner that all materials and equipment furnished under this contract will be new unless otherwise specified, and that all work will be of good quality, free from faults and defects and in conformance with the Contract Documents. All work not so conforming to these standards may be considered defective. If required by Owner, the Contractor shall furnish satisfactory evidence as to the kind and quality of materials and equipment. If within ten (10) days after written notice to the

Contractor requesting such repairs or replacement, the Contractor should neglect to make or undertake with due diligence to the same, the City may make such repairs or replacements. All indirect and direct costs of such correction or removal or replacement shall be at the Contractor's expense. The Contractor will also bear the expenses of making good all work of others destroyed or damaged by the correction, removal or replacement of his defective work.

- 2.12. Permits, Fees, & Notices:** The Contractor shall secure and pay for all permits, governmental fees and licenses necessary for the proper execution and completion of the work. The Contractor shall give all notices and comply with all laws, ordinances, rules, regulations and orders of any public authority bearing on the performance of the work. If the Contractor observes that any of the Contract Documents are at variance in any respect, he shall promptly notify the Owner in writing, and any necessary changes shall be adjusted by approximate modification. If the Contractor performs any work knowing it to be contrary to such laws, ordinances, rules and regulations, and without such notice to the Owner, he shall assume full responsibility and shall bear all costs attributable.
- 2.13. Responsibility for Those Performing the Work:** The Contractor shall be responsible to the Owner for the acts and omissions of all his employees and all sub-contractors, their agents and employees, and all other persons performing any of the work under a contract with the Contractor.
- 2.14. Use of the Site:** The Contractor shall confine operations at the site to areas permitted by law, ordinances, permits and the Contract Documents, and shall not unreasonably encumber the site with any materials or equipment.
- 2.15. Cleanup:** The Contractor at all times shall keep the premises free from accumulation of waste materials or rubbish caused by his operations. At the completion of work he shall remove all his waste materials and rubbish from and about the project, as well as all his tools, construction equipment, machinery and surplus materials.
- 2.16. Insurance:** The Contractor shall secure and maintain such insurance policies as will provide the coverage and contain other provisions specified in the General Contract Conditions, or as modified in the Special Contract Conditions.

The Contractor shall file a copy of the policies or Certificates of Insurance acceptable to the City with the Engineer within ten (10) Calendar Days after issuance of the Notice of Award. These Certificates of Insurance shall contain a provision that coverage afforded under the policies shall not be canceled unless at least thirty (30) Calendar Days prior written notice has been given to the City.

- 2.17. Indemnification:** The Contractor shall defend, indemnify and save harmless the Owner, and all its officers, employees, insurers, and self-insurance pool, from and against all liability, suits, actions, or other claims of any character, name and description brought for or on account of any injuries or damages received or sustained by any person, persons, or property on account of any negligent act or fault of the Contractor, or of any Contractor's agent, employee, sub-contractor or supplier in the execution of, or performance under, any contract which may result from proposal award. Contractor shall

pay any judgment with cost which may be obtained against the Owner growing out of such injury or damages.

- 2.18. Miscellaneous Conditions: Material Availability:** Contractors must accept responsibility for verification of material availability, production schedules, and other pertinent data prior to submission of bid. It is the responsibility of the bidder to notify the Owner immediately if materials specified are discontinued, replaced, or not available for an extended period of time. **OSHA Standards:** All bidders agree and warrant that services performed in response to this invitation shall conform to the standards declared by the US Department of Labor under the Occupational Safety and Health Act of 1970 (OSHA). In the event the services do not conform to OSHA standards, the Owner may require the services to be redone at no additional expense to the Owner.
- 2.19. Time:** Time is of the essence with respect to the time of completion of the Project and any other milestones or deadline which are part of the Contract. It will be necessary for each Bidder to satisfy the City of its ability to complete the Work within the Contract Time set forth in the Contract Documents. The Contract Time is the period of time allotted in the Contract Documents for completion of the work. The date of commencement of the work is the date established in a Notice to Proceed. If there is no Notice to Proceed, it shall be the date of the Contract or such other date as may be established therein, or as established as entered on the Bid Form. The Date of Final Completion of the work is the date certified by the Owner when all construction, and all other work associated to include, but not be limited to: testing, QA/QC, receipt of required reports and/or forms, grant requirements (if applicable), punch list items, clean-up, receipt of drawings and/or as-builts, etc., is fully complete, and in accordance with the Contract Documents.
- 2.20. Progress & Completion:** The Contractor shall begin work on the date of commencement as defined in the Contract and shall carry the work forward expeditiously with adequate forces and shall complete it within the contract time.
- 2.21. Payment & Completion:** The Contract Sum is stated in the Contract and is the total amount payable by the Owner to the Contractor for the performance of the work under the Contract Documents. Upon receipt of written notice that the work is ready for final inspection and acceptance and upon receipt of application for payment, the Owner's Project Manager will promptly make such inspection and, when he finds the work acceptable under the Contract Documents and the Contract fully performed, the Owner shall make payment in the manner provided in the Contract Documents.
- 2.22. Bid Bond:** Each Bid shall as a guaranty of good faith on the part of the Bidder be accompanied by a Bid Guaranty consisting of: a certified or cashier's check drawn on an approved national bank or trust company in the state of Colorado, and made payable without condition to the City; or a **Bid Bond** written by an approved corporate surety in favor of the City. The amount of the Bid Guaranty shall not be less than 5% of the total Bid amount. Once a Bid is accepted and a Contract is awarded, the apparent successful bidder has ten calendar days to enter into a contractor in the form prescribed and to furnish the bonds with a legally responsible and approved surety. Failure to do so will result in forfeiture of the Bid Guaranty to the City as Liquidated Damages.

Each bidder shall guaranty its total bid price for a period of sixty (60) Calendar Days from the date of the bid opening.

- 2.23. Performance & Payment Bonds:** Contractor shall furnish a Performance and a Payment Bond, each in an amount at least equal to that specified for the contract amount as security for the faithful performance and payment of all Contractor's obligations under the Contract Documents. These bonds shall remain in effect for the duration of the Warranty Period (as specified in the Special Conditions). Contractor shall also furnish other bonds that may be required by the Special Conditions. All bonds shall be in the forms prescribed by the Contract Documents and be executed by such sureties as (1) are licensed to conduct business in the State of Colorado and (2) are named in the current list of "Companies Holding Certificates of Authority as Acceptable Sureties on Federal Bonds and as Acceptable Reinsuring Companies" as published in Circular 570 (amended) by the Audit Staff, Bureau of Accounts, U.S. Treasury Department. All bonds signed by an agent must be accompanied by a certified copy of the Authority Act. If the surety on any bond furnished by the Contractor is declared bankrupt, or becomes insolvent, or its rights to do business in Colorado are terminated, or it ceases to meet the requirements of clauses (1) and (2) of this section, Contractor shall within five (5) days thereafter substitute another bond and surety, both of which shall be acceptable to the City.
- 2.24. Retention:** The Owner will deduct money from the partial payments in amounts considered necessary to protect the interest of the Owner and will retain this money until after completion of the entire contract. The amount to be retained from partial payments will be five (5) percent of the value of the completed work, and not greater than five (5) percent of the amount of the Contract. When the retainage has reached five (5) percent of the amount of the Contract no further retainage will be made and this amount will be retained until such time as final payment is made.
- 2.25. Liquidated Damages for Failure to Enter Into Contract:** Should the Successful Bidder fail or refuse to enter into the Contract within ten Calendar Days from the issuance of the Notice of Award, the City shall be entitled to collect the amount of such Bidder's Bid Guaranty as Liquidated Damages, not as a penalty but in consideration of the mutual release by the City and the Successful Bidder of all claims arising from the City's issuance of the Notice of Award and the Successful Bidder's failure to enter into the Contract and the costs to award the Contract to any other Bidder, to re-advertise, or otherwise dispose of the Work as the City may determine best serves its interest.
- 2.26. Liquidated Damages for Failure to Meet Project Completion Schedule:** If the Contractor does not achieve Final Completion by the required date, whether by neglect, refusal or any other reason, the parties agree and stipulate that the Contractor shall pay liquidated damages to the City for each such day that final completion is late. As provided elsewhere, this provision does not apply for delays caused by the City. The date for Final Completion may be extended in writing by the Owner.

The Contractor agrees that as a part of the consideration for the City's awarding of this Contract liquidated damages in the daily amount of **\$500.00** is reasonable and necessary to pay for the actual damages resulting from such delay. The parties agree that the real costs and injury to the City for such delay include hard to quantify items such as:

additional engineering, inspection and oversight by the City and its agents; additional contract administration; inability to apply the efforts of those employees to the other work of the City; perceived inefficiency of the City; citizens having to deal with the construction and the Work, rather than having the benefit of a completed Work, on time; inconvenience to the public; loss of reputation and community standing for the City during times when such things are very important and very difficult to maintain.

The Contractor must complete the Work and achieve final completion included under the Bid Schedule in the number of consecutive calendar days after the City gives is written Notice to Proceed. When the Contractor considers the entire Work ready for its intended use, Contractor shall certify in writing that the Work is fully complete. Final Completion date is the date by which the Contractor shall have fully completed all clean-up, and all items that were identified by the City in the inspection for final completion. Unless otherwise stated in the Special Conditions, for purposes of this liquidated damages clause, the Work shall not be finished and the Contract time shall continue to accrue until the City gives its written Final Acceptance.

If the Contractor shall fail to pay said liquidated damages promptly upon demand thereof after having failed to achieve Final Completion on time, the City shall first look to any retainage or other funds from which to pay said liquidated damages; if retainage or other liquid funds are not available to pay said liquidated damages amounts, the Surety on the Contractor's Performance Bond and Payment Bond shall pay such liquidated damages. In addition, the City may withhold all, or any part of, such liquidated damages from any payment otherwise due the Contractor.

Liquidated damages as provided do not include any sums to reimburse the City for extra costs which the City may become obligated to pay on other contracts which were delayed or extended because of the Contractor's failure to complete the Work within the Contract Time. Should the City incur additional costs because of delays or extensions to other contracts resulting from the Contractor's failure of timely performance, the Contractor agrees to pay these costs that the City incurs because of the Contractor's delay, and these payments are separate from and in addition to any liquidated damages.

The Contractor agrees that the City may use its own forces or hire other parties to obtain Final Completion of the work if the time of completion has elapsed and the Contractor is not diligently pursuing completion. In addition to the Liquidated Damages provided for, the Contractor agrees to reimburse the City for all expenses thus incurred.

- 2.27. Contingency/Force Account/Minor Contract Revisions:** Contingency/Force Account/Minor Contract Revisions work will be authorized by the Owner's Project Manager and is defined as minor expenses to cover miscellaneous or unforeseen expenses related to the project. The expenses are not included in the Drawings, Specifications, or Scope of Work and are necessary to accomplish the scope of this contract. Contingency/Force Account/Minor Contract Revisions Authorization will be directed by the Owner through an approved form. Contingency/Force Account/Minor Contract Revisions funds are the property of the Owner and any Contingency/Force Account/Minor Contract Revisions funds, not required for project completion, shall remain the property of the Owner. Contractor is not entitled to any Contingency/Force Account/Minor Contract Revisions funds, that are not authorized by Owner or Owner's Project Manager.

- 2.28. Protection of Persons & Property:** The Contractor shall comply with all applicable laws, ordinances, rules, regulations and orders of any public authority having jurisdiction for the safety of persons or property or to protect them from damage, injury or loss. Contractor shall erect and maintain, as required by existing safeguards for safety and protection, and all reasonable precautions, including posting danger signs or other warnings against hazards promulgating safety regulations and notifying owners and users of adjacent utilities. When or where any direct or indirect damage or injury is done to public or private property by or on account of any act, omission, neglect, or misconduct by the Contractor in the execution of the work, or in consequence of the non-execution thereof by the Contractor, he shall restore, at his own expense, such property to a condition similar or equal to that existing before such damage or injury was done, by repairing, rebuilding, or otherwise restoring as may be directed, or it shall make good such damage or injury in an acceptable manner.
- 2.29. Changes in the Work:** The Owner, without invalidating the contract, may order changes in the work within the general scope of the contract consisting of additions, deletions or other revisions, the contract sum and the contract time being adjusted accordingly. All such changes in the work shall be authorized by Change Order and shall be executed under the applicable conditions of the contract documents. A Change Order is a written order to the Contractor signed by the Owner issued after the execution of the contract, authorizing a change in the work or an adjustment in the contract sum or the contract time. The contract sum and the contract time may be changed only by Change Order.
- 2.30. Claims for Additional Cost or Time:** If the Contractor wishes to make a claim for an increase in the contract sum or an extension in the contract time, he shall give the Owner written notice thereof within a reasonable time after the occurrence of the event giving rise to such claim. This notice shall be given by the Contractor before proceeding to execute the work, except in an emergency endangering life or property in which case the Contractor shall precede in accordance with the regulations on safety. No such claim shall be valid unless so made. Any change in the contract sum or contract time resulting from such claim shall be authorized by Change Order.
- 2.31. Minor Changes in the Work:** The Owner shall have authority to order minor changes in the work not involving an adjustment in the contract sum or an extension of the contract time and not inconsistent with the intent of the contract documents.
- 2.32. Field Orders:** The Owner may issue written Field Orders which interpret the Contract Documents in accordance with the specifications, or which order minor changes in the work in accordance with the agreement, without change in the contract sum or time. The Contractor shall carry out such Field Orders promptly.
- 2.33. Uncovering & Correction of Work:** The Contractor shall promptly correct all work rejected by the Owner as defective or as failing to conform to the contract documents whether observed before or after substantial completion and whether or not fabricated installed or competed. The Contractor shall bear all costs of correcting such rejected work, including the cost of the Owner's additional services thereby made necessary. If within one (1) year after the date of completion or within such longer period of time as may be prescribed by law or by the terms of any applicable special guarantee required

by the contract documents, any of the work found to be defective or not in accordance with the contract documents, the Contractor shall correct it promptly after receipt of a written notice from the Owner to do so unless the Owner has previously given the Contractor a written acceptance of such condition. The Owner shall give such notice promptly after discover of condition. All such defective or non-conforming work under the above paragraphs shall be removed from the site where necessary and the work shall be corrected to comply with the contract documents without cost to the Owner. The Contractor shall bear the cost of making good all work of separate Contractors destroyed or damaged by such removal or correction. If the Owner prefers to accept defective or non-conforming work, he may do so instead of requiring its removal and correction, in which case a Change Order will be issued to reflect an appropriate reduction in the payment or contract sum, or, if the amount is determined after final payment, it shall be paid by the Contractor.

- 2.34. Amendment:** No oral statement of any person shall modify or otherwise change, or affect the terms, conditions or specifications stated in the resulting contract. All amendments to the contract shall be made in writing by the Owner.
- 2.35. Assignment:** The Contractor shall not sell, assign, transfer or convey any contract resulting from this IFB, in whole or in part, without the prior written approval from the Owner.
- 2.36. Compliance with Laws:** Bids must comply with all Federal, State, County and local laws governing or covering this type of service and the fulfillment of all ADA (Americans with Disabilities Act) requirements.
- 2.37. Confidentiality:** All information disclosed by the Owner to the Contractor for the purpose of the work to be done or information that comes to the attention of the Contractor during the course of performing such work is to be kept strictly confidential.
- 2.38. Conflict of Interest:** No public official and/or City/County employee shall have interest in any contract resulting from this IFB.
- 2.39. Contract Termination:** This contract shall remain in effect until any of the following occurs: (1) contract expires; (2) completion of services; (3) acceptance of services or, (4) for convenience terminated by either party with a written *Notice of Cancellation* stating therein the reasons for such cancellation and the effective date of cancellation.
- 2.40. Employment Discrimination:** During the performance of any services per agreement with the Owner, the Contractor, by submitting a Bid, agrees to the following conditions:
- 2.40.1.** The Contractor shall not discriminate against any employee or applicant for employment because of race, religion, color, sex, age, handicap, or national origin except when such condition is a legitimate occupational qualification reasonably necessary for the normal operations of the Contractor. The Contractor agrees to post in conspicuous places, visible to employees and applicants for employment, notices setting forth the provisions of this nondiscrimination clause.

- 2.40.2.** The Contractor, in all solicitations or advertisements for employees placed by or on behalf of the Contractor, shall state that such Contractor is an Equal Opportunity Employer.
- 2.40.3.** Notices, advertisements, and solicitations placed in accordance with federal law, rule, or regulation shall be deemed sufficient for the purpose of meeting the requirements of this section.
- 2.41. Affirmative Action:** In executing a Contract with the City, the Contractor agrees to comply with Affirmative Action and Equal Employment Opportunity regulations presented in the General Contract Conditions.
- 2.42. Immigration Reform and Control Act of 1986 and Immigration Compliance:** The Offeror certifies that it does not and will not during the performance of the contract employ illegal alien workers or otherwise violate the provisions of the Federal Immigration Reform and Control Act of 1986 and/or the immigration compliance requirements of State of Colorado C.R.S. § 8-17.5-101, *et. seq.* (House Bill 06-1343).
- 2.43. Ethics:** The Contractor shall not accept or offer gifts or anything of value nor enter into any business arrangement with any employee, official, or agent of the Owner.
- 2.44. Failure to Deliver:** In the event of failure of the Contractor to deliver services in accordance with the contract terms and conditions, the Owner, after due oral or written notice, may procure the services from other sources and hold the Contractor responsible for any costs resulting in additional purchase and administrative services. This remedy shall be in addition to any other remedies that the Owner may have.
- 2.45. Failure to Enforce:** Failure by the Owner at any time to enforce the provisions of the contract shall not be construed as a waiver of any such provisions. Such failure to enforce shall not affect the validity of the contract or any part thereof or the right of the Owner to enforce any provision at any time in accordance with its terms.
- 2.46. Force Majeure:** The Contractor shall not be held responsible for failure to perform the duties and responsibilities imposed by the contract due to legal strikes, fires, riots, rebellions, and acts of God beyond the control of the Contractor, unless otherwise specified in the contract.
- 2.47. Independent Contractor:** The Contractor shall be legally considered an Independent Contractor and neither the Contractor nor its employees shall, under any circumstances, be considered servants or agents of the Owner. The Owner shall be at no time legally responsible for any negligence or other wrongdoing by the Contractor, its servants, or agents. The Owner shall not withhold from the contract payments to the Contractor any federal or state unemployment taxes, federal or state income taxes, Social Security Tax or any other amounts for benefits to the Contractor. Further, the Owner shall not provide to the Contractor any insurance coverage or other benefits, including Workers' Compensation, normally provided by the Owner for its employees.
- 2.48. Nonconforming Terms and Conditions:** A bid that includes terms and conditions that do not conform to the terms and conditions of this Invitation for Bid is subject to rejection

as non-responsive. The Owner reserves the right to permit the Contractor to withdraw nonconforming terms and conditions from its bid prior to a determination by the Owner of non-responsiveness based on the submission of nonconforming terms and conditions.

Items for non-responsiveness may include, but not be limited to:

- a. Submission of the Bid on forms other than those supplied by the City;
- b. Alteration, interlineation, erasure, or partial detachment of any part of the forms which are supplied herein;
- c. Inclusion of unauthorized additions conditional or alternate Bids or irregularities of any kind which may tend to make the Bid incomplete, indefinite, or ambiguous as to its meaning;
- d. Failure to acknowledge receipt of any or all issued Addenda;
- e. Failure to provide a unit price or a lump sum price, as appropriate, for each pay item listed except in the case of authorized alternative pay items;
- f. Failure to list the names of Subcontractors used in the Bid preparation as may be required in the Solicitation Documents;
- g. Submission of a Bid that, in the opinion of the Owner, is unbalanced so that each item does not reasonably carry its own proportion of cost or which contains inadequate or unreasonable prices for any item;
- h. Tying of the Bid with any other bid or contract; and
- i. Failure to calculate Bid prices as described herein.

2.49. Evaluation of Bids and Offerors: The Owner reserves the right to:

- reject any and all Bids,
- waive any and all informalities,
- take into account any prompt payment discounts offered by Bidder,
- negotiate final terms with the Successful Bidder,
- take into consideration past performance of previous awards/contracts with the Owner of any Contractor, Vendor, Firm, Supplier, or Service Provider in determining final award. and
- disregard any and all nonconforming, nonresponsive or conditional Bids.

Discrepancies between words and figures will be resolved in favor of words. Discrepancies between Unit Prices and Extended Prices will be resolved in favor of the Unit Prices. Discrepancies between the indicated sum of any column of figures and the correct sum thereof will be resolved in favor of the correct sum. The corrected extensions and totals will be shown in the tabulation of Bids.

The Owner may consider the qualifications and experience of Subcontractors and other persons and organizations (including those who are to furnish the principal items of material or equipment) proposed for those portions of the work as to which the identity of Subcontractors and other persons and organizations must be submitted. Operating costs, maintenance considerations performance data, and guarantees of materials and equipment may also be considered by the Owner.

The Owner will conduct such investigations as deemed necessary to assist in the evaluation of any Bid and to establish the responsibility, qualifications and financial ability of the Offeror, proposed Subcontractors and other persons and organizations to do the Work in accordance with the *Contract Documents* to the City's satisfaction within the Contract Time.

The Offeror shall furnish the Owner all information and data requested by the Owner to determine the ability of the Offeror to perform the Work. The Owner reserves the right to reject the Bid if the evidence submitted by, or investigation of such Offeror fails to satisfy the Owner that such Offeror is properly qualified to carry out the obligations of the Contract and to complete the Work contemplated therein.

By submitting a Bid, each Offeror authorizes the Owner to perform such investigation of the Offeror as the Owner deems necessary to establish the responsibility, qualifications and financial ability of the Offeror and, by its signature thereon, authorizes the Owner to obtain reference information concerning the Offeror and releases the party providing such information and the Owner from any and all liability to the Offeror as a result of such reference information so provided.

The Owner reserves the right to reject the Bid of any Offeror who does not pass any evaluation to the Owner's satisfaction.

If the Contract is to be awarded, it will be awarded to the Offeror who, by evaluation, the Owner determines will best meet the Owner's interests.

The Owner reserves the right to accept or reject the Work contained in any of the Price Bid Schedules or alternates, either in whole or in part.

2.50. Award of Contract: Unless otherwise indicated, a single award will be made for all the bid items in an individual bid schedule. In the event that the Work is contained in more than one Bid Schedule, the City may award Schedules individually or in combination. In the case of two Bid Schedules which are alternative to each other, only one of such alternative Schedules will be awarded. Within forty-five (45) Calendar Days of Bid Opening, the City will issue a Notice of Award to the Successful Bidder which will be accompanied by four (4) unsigned copies of the Contract and the Performance and Payment Bond forms. Within ten (10) Calendar Days thereafter, the Successful Bidder shall sign and deliver four (4) copies of the Contract, Performance Bond, Payment Bond and Certificates of Insurance to the City. Within ten (10) Calendar Days thereafter, the City will deliver two (2) fully executed counterparts of the Contract to the Contractor. No contract shall exist between the Successful Bidder and the City and the Successful Bidder shall have no rights at law or in equity until the Contract has been duly executed by the City.

The Successful Bidder's failure to sign and submit a Contract and other documents set forth in this Paragraph within the prescribed time shall be just cause of annulment of the award, and forfeiture of the Bid Guaranty. The award of Contract may then be made to the next qualified Bidder in the same manner as previously prescribed.

- 2.51. Ownership:** All plans, prints, designs, concepts, etc., shall become the property of the Owner.
- 2.52. Oral Statements:** No oral statement of any person shall modify or otherwise affect the terms, conditions, or specifications stated in this document and/or resulting agreement. All modifications to this request and any agreement must be made in writing by the Owner.
- 2.53. Patents/Copyrights:** The Contractor agrees to protect the Owner from any claims involving infringements of patents and/or copyrights. In no event shall the Owner be liable to the Contractor for any/all suits arising on the grounds of patent(s)/copyright(s) infringement. Patent/copyright infringement shall null and void any agreement resulting from response to this IFB.
- 2.54. Remedies:** The Contractor and Owner agree that both parties have all rights, duties, and remedies available as stated in the Uniform Commercial Code.
- 2.55. Venue:** Any agreement as a result of responding to this IFB shall be deemed to have been made in, and shall be construed and interpreted in accordance with, the laws of the City of Grand Junction, Mesa County, Colorado.
- 2.56. Expenses:** Expenses incurred in preparation, submission and presentation of this IFB are the responsibility of the company and cannot be charged to the Owner.
- 2.57. Sovereign Immunity:** The Owner specifically reserves its right to sovereign immunity pursuant to Colorado State Law as a defense to any action arising in conjunction to this agreement.
- 2.58. Non-Appropriation of Funds:** The contractual obligation of the Owner under this contract is contingent upon the availability of appropriated funds from this fiscal year budget as approved by the City Council or Board of County Commissioners from this fiscal year only. State of Colorado Statutes prohibit obligation of public funds beyond the fiscal year for which the budget was approved. Anticipated expenditures/obligations beyond the end of the current Owner's fiscal year budget shall be subject to budget approval. Any contract will be subject to and must contain a governmental non-appropriation of funds clause.
- 2.59. Cooperative Purchasing:** Purchases as a result of this solicitation are primarily for the City/County. Other governmental entities may be extended the opportunity to utilize the resultant contract award with the agreement of the successful provider and the participating agencies. All participating entities will be required to abide by the specifications, terms, conditions and pricings established in this Bid. The quantities furnished in this bid document are for only the City/County. It does not include quantities

for any other jurisdiction. The City or County will be responsible only for the award for its jurisdiction. Other participating entities will place their own awards on their respective Purchase Orders through their purchasing office or use their purchasing card for purchase/payment as authorized or agreed upon between the provider and the individual entity. The City/County accepts no liability for payment of orders placed by other participating jurisdictions that choose to piggy-back on our solicitation. Orders placed by participating jurisdictions under the terms of this solicitation will indicate their specific delivery and invoicing instructions.

- 2.60. Keep Jobs in Colorado Act:** Contractor shall be responsible for ensuring compliance with Article 17 of Title 8, Colorado Revised Statutes requiring 80% Colorado labor to be employed on public works. Contractor shall, upon reasonable notice provided by the Owner, permit the Owner to inspect documentation of identification and residency required by C.R.S. §8-17-101(2)(a). If Contractor claims it is entitled to a waiver pursuant to C.R.S. §8-17-101(1), Contractor shall state that there is insufficient Colorado labor to perform the work such that compliance with Article 17 would create an undue burden that would substantially prevent a project from proceeding to completion, and shall include evidence demonstrating the insufficiency and undue burden in its response.

Unless expressly granted a waiver by the Owner pursuant to C.R.S. §8-17-101(1), Contractor shall be responsible for ensuring compliance with Article 17 of Title 8, Colorado Revised Statutes requiring 80% Colorado labor to be employed on public works. Contractor shall, upon reasonable notice provided by the Owner, permit the Owner to inspect documentation of identification and residency required by C.R.S. §8-17-101(2)(a).

2.60.1. "Public project" is defined as:

- (a) any construction, alteration, repair, demolition, or improvement of any land, building, structure, facility, road, highway, bridge, or other public improvement suitable for and intended for use in the promotion of the public health, welfare, or safety and any maintenance programs for the upkeep of such projects
- (b) for which appropriate or expenditure of moneys may be reasonably expected to be \$500,000.00 or more in the aggregate for any fiscal year
- (c) except any project that receives federal moneys.

3. Statement of Work

- 3.1. GENERAL:** The City of Grand Junction is soliciting competitive bids from qualified and interested companies for all labor, equipment, and materials required for the **2021 G Road Irrigation Modification Project**. All dimensions and scope of work should be verified by Contractors prior to submission of bids.

NOTE: The descriptions of the pay items listed in the Price Bid Schedule for this Project may not agree with those listed in the Standard Specifications. Payment for all Work performed, as required in the Contract Documents, will be in accordance with the items and units listed in the Price Bid Schedule.

The performance of the Work for this Project shall conform to the General Contract conditions presented in the City of Grand Junction's Standard Contract Documents for Capital Improvements Construction, revised July 2010, except as specifically modified or supplemented herein or on the Construction Drawings.

3.2. PROJECT DESCRIPTION: The Project generally consists of installing 710 L.F. of 18" corrugated HDPE irrigation pipe, 5 irrigation structures, removal of concrete irrigation ditches, traffic control, and the restoration of disturbed areas including, gravel and asphalt road surfaces, driveways, and concrete replacement.

3.3. SPECIAL CONDITIONS & PROVISIONS:

3.3.1 Mandatory Site Visit Meeting: **Prospective bidders are required to attend a site visit meeting on February 9, 2021 at 10:30 am.** Meeting location will be at the south end of Canyon View Park on G Road. Park in the diagonal parking spaces along the northside of G Road at Canyon View Park. The purpose of this visit will be to inspect and to clarify the contents of this Invitation for Bids (IFB).

3.3.2 QUESTIONS REGARDING SOLICIATION PROCESS/SCOPE OF WORK:

Duane Hoff, Senior Buyer
City of Grand Junction
duaneh@gjcity.org
970-244-1545

3.3.3 Project Manager: The Project Manager for the Project is Lee Cooper, Project Engineer, who can be reached at (970) 256-4155. During Construction, all notices, letters, submittals, and other communications directed to the City shall be addressed and mailed or delivered to:

City of Grand Junction
Department of Public Works - Engineering
Attn: Lee Cooper, Project Manager
333 West Ave., Building C
Grand Junction, CO 81501

3.3.4 Affirmative Action: The Contractor is not required to submit a written Affirmative Action Program for the Project.

3.3.5 Pricing: Pricing shall be all inclusive to include but not be limited to: all labor, equipment, supplies, materials, freight (F.O.B. Destination – Freight Pre-paid and Allowed to each site), travel, mobilization costs, fuel, set-up and take down costs, and full-time inspection costs, and all other costs related to the successful completion of the project.

The Owner shall not pay nor be liable for any other additional costs including but not limited to: taxes, shipping charges, insurance, interest, penalties, termination payments, attorney fees, liquidated damages, etc.

3.3.6 Freight/Shipping: All freight/shipping shall be F.O.B. Destination – Freight

Pre-Paid and Allowed to the project site(s), Grand Junction, CO.

Contractor must meet all federal, state, and local rules, regulations, and requirements for providing such services.

3.3.7 Contract: A binding contract shall consist of: (1) the IFB and any amendments thereto, (2) the bidder's response (bid) to the IFB, (3) clarification of the bid, if any, and (4) the City's Purchasing Department's acceptance of the bid by "Notice of Award" or by "Purchase Order". All Exhibits and Attachments included In the IFB shall be incorporated into the contract by reference.

A. The contract expresses the complete agreement of the parties and, performance shall be governed solely by the specifications and requirements contained therein.

B. Any change to the contract, whether by modification and/or supplementation, must be accomplished by a formal contract amendment signed and approved by and between the duly authorized representative of the bidder and the City Purchasing Division or by a modified Purchase Order prior to the effective date of such modification. The bidder expressly and explicitly understands and agrees that no other method and/or no other document, including acts and oral communications by or from any person, shall be used or construed as an amendment or modification to the contract.

3.3.8 Time of Completion: The scheduled time of Completion for the Project is **45 Calendar Days** from the starting date specified in the Notice to Proceed.

Completion is achieved when site cleanup and all punch list items (resulting from the final inspection) have been completed. Completion shall have the meaning set forth in Article I, Section 3 (Definitions and Terms) of the General Contract Conditions.

3.3.9 Working Days and Hours: The working days and hours shall be as stated in the General Contract Conditions, Section VI - Contractor's Responsibilities, Subsection 36; or as mutually agreed upon in the preconstruction meeting.

3.3.10 Licenses and Permits: Contractor is responsible for obtaining all necessary licenses and permits required for Construction, at Contractors expense. See Section 2.12. Contractor shall supply to Owner all copies of finalized permits.

3.3.11 Permits: The following permits are required for the Project and will be obtained by the City at no cost to the Contractor:

- None

The following permits are required for the Project and shall be obtained and paid for by the Contractor, with the costs included in the total bid price for the Project:

- Colorado Department of Public Health and Environment Dewatering Permit: (If necessary due to the presence of groundwater) For more information,

contact the Colorado Dept. of Public Health and Environment: www.cdphe.state.co.us/wq/PermitsUnit/wqcdpmt.html Approximately 7 – 10 days is required for processing of the permit application. The Contractor should begin preparing the permit application immediately upon notice of award.

3.3.12 City Furnished Materials: The City will furnish the following materials for the Project:

- AutoCAD drawings for survey stake-out
- Variable message boards for upcoming construction locations

3.3.13 Project Newsletters: A newsletter for the Project will be prepared and distributed by the City. It will include general information about the Project including street closures, parking restrictions, project schedule, and the names and telephone numbers of the contacts for the City and Contractor. The newsletter will be mailed approximately one week before the Contractor commences work.

3.3.14 Project Sign: Project signs, if any, will be furnished and installed by the City.

3.3.15 Authorized Representatives of the City: Those authorized to represent the City shall include Purchasing Agent, Engineers, and Inspectors employed by the City, only.

3.3.16 Stockpiling Materials and Equipment: All stockpiling/storage shall be in accordance with General Contract Condition Section 51.

3.3.17 Traffic Control: The Contractor shall provide and maintain traffic control in accordance with the approved Traffic Control Plan and the *Manual on Uniform Traffic Control Devices (MUTCD)*. The traffic control plans shall be presented to the Project Engineer at or prior to the pre-construction meeting for review and approval. The following requirements and limitations shall apply to the traffic control:

No personal driveway and/or access point to a property shall be left inaccessible at the end of each work day or over a weekend; and no construction equipment shall be parked in front of a driveway and/or access point during Contractor's non-working hours. When a driveway and/or access point has to be closed off due to construction activity, the Contractor shall provide advanced notification to the affected resident(s) at least two-days prior to closure and arrange an alternative access point to the property. Refer to General Contract Condition 26 – Maintenance of Access and Services.

Special conditions for traffic control:

1. All trenches shall be backfilled or protected at the end of each working day and access restored to all driveways. If trenches are left open at night, the trenches will be limited to 30 feet in length. The entire perimeter of the excavation shall be barricaded with construction equipment and/or temporary construction fence.

2. At all times during the project, the contractor must ensure access is available for the U.S. Postal Service, trash collection trucks, school buses, emergency vehicles, etc., per the General Contract Conditions.
3. The Contractor shall adhere to all traffic control requirements when working within City right-of-way. While the Contractor is working between stationing 0+92 to 1+78, the City will allow G Road to be closed to traffic and detours provided. When the Contractor is working between stationing 1+78 to 14+35, the City will allow the westbound lane of G Road to be closed to allow additional room for construction operations. In all cases, G Road shall be opened to eastbound and westbound traffic at the end of each workday and on the weekends. The G Road closure and/or the westbound lane closures shall start at 8 am at the earliest.
4. Detours shall be provided when G Road is closed to through traffic; as well as when the westbound lane of G Road is closed for irrigation construction. Residents, employees, property owners shall have access to their respected properties during construction.
5. Access to residents and/or businesses shall always be provided during construction.

3.3.18 Clean-Up: The Contractor is responsible for cleaning up all loose materials that have been deposited or swept into gutters, and onto sidewalks and driveways as a result of sidewalk operations. The costs for all clean-up work shall be considered incidental and will not be paid for separately.

3.3.19 Quality Assurance Testing: The City will be providing quality assurance (QA) testing on this irrigation project.

3.3.20 Schedule of Submittals: Contractor shall deliver these submittals at least two days prior to the pre-construction meeting:

- Traffic Control Plans
- Construction Schedule submitted at or prior to the pre-construction meeting
- Irrigation Pipe – 18” Corrugated HDPE Pipe (ADS N-12 Dual-Wall Watertight (WTIB) Pipe or Engineer Approved Equal)
- Irrigation Structures
- Slide Gates (Fresno Series 5500 Galvanized Toggle Gates or Engineer Approved Equal)
- Aluminum Bar Grating
- Bedding Gradation, Type A
- Base Course Gradation & Proctor Curve (Class 6)
- Hot Bituminous Pavement Mix Design

3.3.21 Uranium Mill Tailings: It is anticipated that radioactive mill tailings will not be encountered on this Project.

3.3.22 Fugitive Petroleum or Other Contamination: It is anticipated that soil contamination from fugitive petroleum or other contaminants will not be encountered with the Project.

3.3.23 Excess Material: All excess materials shall be disposed in accordance with General Contract Condition Section 50.

3.3.24 Existing Utilities and Structures: A Subsurface Utility Engineering (SUE) investigation was completed for this Project. Information on the existing underground utilities are shown on the SUE plans; as well as the plan and profile sheets. It is the responsibility of the Contractor to locate and protect all structures and utilities in accordance with General Contract Condition Section 37.

If the Contractor discovers a conflict with an existing utility (either horizontal or vertical), the Contractor shall contact the Project Engineer and the utility owner immediately to assist in resolving the conflict.

At this time, the City predicts from the test hole data completed that the following utilities will need to be relocated. At approximate stationing 2+75 an existing domestic waterline service and an existing buried telephone service will need to be adjusted; as well as, at stationing 3+35 an existing gas line service may need to be adjusted to allow installation of the new 18" HDPE irrigation pipe.

The City has notified Xcel Energy and Century Link prior to this Project being awarded a construction contract that these two existing utilities may need to be adjusted. A Pay Item has been provided for the Contractor to adjust the existing water service to accommodate the new 18" HDPE irrigation pipe.

3.3.25 Existing Property Pins and Survey Monuments: The City of Grand Junction did not perform an exhaustive search for existing property pins when compiling survey data for this Project. Property pins and survey monuments have been shown on the construction drawings that were found in the field. The Contractor shall be responsible for locating, protecting and resetting property pins when and where necessary, including those shown on the plans, and including those not shown but found in the field during the course of the work. The cost of locating, protecting, referencing and resetting of property pins is incidental to the Construction Surveying pay item. The cost of referencing and resetting of survey monuments shall be paid for as described in Section 629 – Survey Monumentation within the July 2010 Standard Contract Documents.

3.3.26 Incidental Items: Any item of work not specifically identified or paid for directly, but which is necessary for the satisfactory completion of any paid items of work, will be considered as incidental to those items, and will be included in the cost of those items.

3.3.27 Existing Concrete Sidewalks, Pans, Fillets, Curbs and Gutters: The existing sidewalks, pans, fillets, curb and gutter are in good serviceable condition. In most instances the installation of new sidewalk and pavement will be adjacent to existing concrete. The Contractor will need to protect all concrete adjacent to construction. If the concrete is damaged during construction the Contractor will be responsible for its

replacement at no cost to the City. The Contractor, the City Project Inspector, and/or the City Project Manager will walk and record any concrete that is deemed to be damaged before construction has started.

- 3.3.28 ACI Concrete and Flatwork Finisher and Technician:** Hand finishing concrete will be permitted only when performed under the direct supervision of a craftsman holding the following certificate: ACI Concrete Flatwork Finisher and Technician (ACICFFT) or other Flatwork Finisher certification program approved by the City Engineering Manager.
- 3.3.29 Confined Space Entry:** The Contractor is responsible for providing any and all confined space entry safety equipment; including, but not limited to: air testing equipment, fresh air blowers, tripods, harnesses, and SCBA equipment. The Contractor's air monitoring devices shall be calibrated and certified. The cost for all confined space entry equipment shall be incidental to the project cost, and will not be paid for separately.
- 3.3.30 Construction Dewatering:** All construction dewatering must meet the requirements specified in the CDPHE Dewatering Permit. Construction dewatering will be considered incidental and will not be measured and paid for separately.
- 3.3.31 Temporary Steel Plating:** If the Contractor chooses to use steel plates to protect an open trench section, the cost for supplying and securely placing the steel plates will not be paid for separately but shall be included in the work.
- 3.3.32 Payment for Damage to Private Property beyond Easement Limits/ROW Limits:** Easement and Right-of-Way (ROW) lines are indicated on the Construction Plans. Any and all damage to improvements outside of easements and ROW, and/or outside the Construction Limit lines shall be repaired at the Contractor's expense. There will be no additional payment made for restoration of sod, landscaping, gravel, concrete or asphalt driveways, irrigation systems, decorative borders, fences, etc. beyond the property line or the construction easements as shown on the plan set.
- 3.3.33 Interruption of Utilities and Services:** The Contractor shall notify all property owners affected by the interruption of utilities and other services caused by his operation. Such notice shall be given at least 24 hours prior to the interruption. Notice shall be given for, but not limited to the interruption of domestic water, sanitary sewer, gas service, electric service, trash pickup, mail delivery and changes in access to the property.
- 3.3.34 Construction Surveying & "As-Built" Drawings:** In addition to Items I and II in the General Contract Conditions, Section 54, As-Built record information will be provided to, and approved by City staff prior to Final Acceptance of the Project. Information to be provided must be in electronic format (e.g. AutoCAD and/or survey files) along with a PDF set of As-Built drawings. As-Built electronic files must contain information suitable for the City to maintain Utility records to the standards set forth in the new Colorado 811 One Call/Subsurface Utility Law (effective August 8, 2018) and standards as described in the American Society of Civil Engineers (ASCE) Standard Guidelines for the Collection and Depiction of Existing Subsurface Utility Data (ASCE 38-02).

Electronic information for As-Built records shall include, but is not limited to, verification of all horizontal and vertical changes in pipe alignments, elbows, tees, manholes, valves, control structures, service taps, service pipe (horizontal and vertical deflections to ROW line, meter pits, or clean-outs, whichever is closer), beginning and ending of slip-lined segments, tie-in or connection to existing infrastructure, etc. Distance between As-Built data points along pipe alignment is dependent on the amount of deflection used to install the pipe in the field. There must be sufficient point data to create a plan and profile of all infrastructure accurate to within eighteen inches (18”) of the physical structures anywhere along the project.

The cost for all surveying the all fittings, both sewer and water, shall be incidental to the project cost, and will not be paid for separately.

3.3.35 As-Built Irrigation Manholes/Structures Survey Shots: All new irrigation structures require as-built survey shots on all pipe inverts.

3.4. SCOPE OF WORK: The Project generally consists of installing 710 L.F. of corrugated HDPE irrigation pipe, 5 irrigation structures, removal of concrete irrigation ditches, traffic control, and the restoration of disturbed areas including, gravel and asphalt road surfaces, driveways, and concrete replacement.

3.5. Attachments:

- Appendix A: Project Submittal Form
- Appendix B: Project Special Provisions
- Construction Plans

3.6. Contractor Bid Documents: For Contractor’s convenience, the following is a list of forms/items to be submitted with the Contractor’s bid response. However, should a form/item not be listed in this section, but required in the solicitation documents, it is the Contractor’s responsibility to ensure all forms/items are submitted.

- Contractor’s Bid Form
- Price Bid Schedule

3.7. IFB TENTATIVE TIME SCHEDULE:

Invitation for Bids available:	January 29, 2021
Mandatory Site Visit Meeting:	February 9, 2021
Inquiry deadline, no questions after this date:	February 12, 2021
Addendum Posted:	February 16, 2021
Submittal deadline for proposals (Bid Opening):	February 19, 2021
City Manager Approval:	February 24, 2021
Notice of Award & Contract execution:	February 25, 2021
Bonding & Insurance Cert. due:	March 8, 2021
Preconstruction meeting:	March 9, 2021
Work begins no later than:	Upon Receipt of Notice to Proceed
Final Completion:	45 Calendar Days from Notice to Proceed
Holidays:	None

4. Contractor's Bid Form

Bid Date: _____

Project: IFB-4870-21-DH "2021 G Road Irrigation Modification Project"

Bidding Company: _____

Name of Authorized Agent: _____

Email _____

Telephone _____ **Address** _____

City _____ **State** _____ **Zip** _____

The undersigned Bidder, in compliance with the Invitation for Bids, having examined the Instruction to Bidders, General Contract Conditions, Statement of Work, Specifications, and any and all Addenda thereto, having investigated the location of, and conditions affecting the proposed work, hereby proposes to furnish all labor, materials and supplies, and to perform all work for the Project in accordance with Contract Documents, within the time set forth and at the prices stated below. These prices are to cover all expenses incurred in performing the work required under the Contract Documents, of which this Contractor's Bid Form is a part.

The undersigned Contractor does hereby declare and stipulate that this offer is made in good faith without collusion or connection to any person(s) providing an offer for the same work, and that it is made in pursuance of, and subject to, all terms and conditions of the Instructions to Bidders, the Specifications, and all other Solicitation Documents, all of which have been examined by the undersigned.

The Contractor also agrees that if awarded the Contract, to provide insurance certificates within ten (10) working days of the date of Notification of Award. Submittal of this offer will be taken by the Owner as a binding covenant that the Contractor will be prepared to complete the project in its entirety.

The Owner reserves the right to make the award on the basis of the offer deemed most favorable, to waive any formalities or technicalities and to reject any or all offers. It is further agreed that this offer may not be withdrawn for a period of sixty (60) calendar days after closing time. Submission of clarifications and revised offers automatically establish a new thirty day (30) period.

Prices in the bid proposal have not knowingly been disclosed with another provider and will not be prior to award.

- Prices in this bid proposal have been arrived at independently, without consultation, communication or agreement for the purpose of restricting competition.
- No attempt has been made nor will be to induce any other person or firm to submit a bid proposal for the purpose of restricting competition.
- The individual signing this bid proposal certifies they are a legal agent of the offeror, authorized to represent the offeror and is legally responsible for the offer with regard to supporting documentation and prices provided.
- Direct purchases by the City of Grand Junction are tax exempt from Colorado Sales or Use Tax. Tax exempt No. 98-903544. The undersigned certifies that no Federal, State, County or Municipal tax will be added to the above quoted prices.
- City of Grand Junction payment terms shall be Net 30 days.
- Prompt payment discount of _____ percent of the net dollar will be offered to the Owner if the invoice is paid within _____ days after the receipt of the invoice. The Owner reserves the right to take into account any such discounts when determining the bid award.

RECEIPT OF ADDENDA: the undersigned Contractor acknowledges receipt of Addenda to the Solicitation, Specifications, and other Contract Documents.

State number of Addenda received: _____.

It is the responsibility of the Bidder to ensure all Addenda have been received and acknowledged.

By signing below, the Undersigned agree to comply with all terms and conditions contained herein.

Company: _____

Authorized Signature: _____

Title: _____

Bid Schedule: 2021 G Road Irrigation Modification Project

Item No.	CDOT, City Ref.	Description	Quantity	Units	Unit Price	Total Price
1	108.2	8" Plastic Starter Coupler (Gasket x Spigot) (8" O.D.) (For use in the Rectangular Box Structure #147)	1.	Each	\$ _____	\$ _____
2	108.2	10" Irrigation Pipe (AWWA C-900, DR-18) (Structure #23 Water Drain Pipe to Leach Creek)	25.	Lin. Ft.	\$ _____	\$ _____
3	108.2	10" Irrigation Pipe (CMP) (Galvanized CMP at Structure #23) (Includes cost of connection into existing CMP pipe that crosses Leach Creek)	10.	Lin. Ft.	\$ _____	\$ _____
4	108.2	12" Irrigation Pipe (AWWA C-900, DR-18) (Includes Type A Bedding and Haunching Material and Backfill of Trench with Native Materials meeting 103.16 Earth Backfill Material)	80.	Lin. Ft.	\$ _____	\$ _____
5	108.2	18" Irrigation Pipe (RCP) (Includes Cost of Connection to Existing RCP pipe and Type A Bedding and Haunching Material and Backfill of Trench with Native Materials meeting 103.16 Earth Backfill Material)	10.	Lin. Ft.	\$ _____	\$ _____
6	108.2	18" Irrigation Pipe (HDPE) (Corrugated HDPE ADS N-12 Dual-Wall, Water Tight (WTIB) Pipe or Engineer Approved Equal) (20-ft Pipe Lengths) (Includes Type A Bedding and Haunching Material and Backfill of Trench with Native Materials meeting 103.16 Earth Backfill Material)	710.	Lin. Ft.	\$ _____	\$ _____
7	108.2	18" Double Wide Field Repair Coupler by ADS or Project Engineer Approved Equal (Use for Connecting new 18" HDPE pipe to Existing 18" HDPE Pipe) (Includes Pouring a Concrete Collar around Repair Coupler for added support)	2.	Each	\$ _____	\$ _____
8	108.2	Imported Trench Backfill (Class 3) (Includes haul and disposal of unsuitable excavated material) (Assumed material unit weight = 133 lbs/ft ³)	40.	Ton	\$ _____	\$ _____

Bid Schedule: 2021 G Road Irrigation Modification Project

Item No.	CDOT, City Ref.	Description	Quantity	Units	Unit Price	Total Price
9	108.2	Imported Trench Backfill (Clean Fill Dirt) (Clean Fill Dirt shall be used where there isn't enough native material available to backfill new irrigation pipe trench) (Anticipated for use between Pipe Stations 1+78 to 14+35)	250.	Cu. Yd.	\$ _____	\$ _____
10	108.5	Irrigation Basic Manhole (36" I.D.) (Includes Concrete Lid Slab with Cast-in-Flush Inverted Aluminum Ring and Cover with the word "Irrigation" Cast into the Cover)	2.	Each	\$ _____	\$ _____
11	108.5	Irrigation Basic Manhole (48" I.D.) (Includes Concrete Lid Slab with Cast-in-Flush Inverted Aluminum Ring and Cover with the word "Irrigation" Cast into the Cover)	1.	Each	\$ _____	\$ _____
12	108.5	Irrigation Structure Manhole (48" I.D.) (See Structure #23 Details) (Includes Fresno Series 5500 Galvanized Toggle Gates (3 Total) or Engineer Approved Equal, and Aluminum Bar Grating and Locking Bar Assembly as shown in detail)	1.	Each	\$ _____	\$ _____
13	108.5	Manhole Barrel Section (48" I.D.) (D>5')	4.	Vert. Ft.	\$ _____	\$ _____
14	108.5	Rectangular Irrigation Structure (24" x 36") (Large Area Inlet Box with Aluminum Bar Grating per Structure #147 Detail) (See City Std. Detail D-10 for Concrete Box Details)	1.	Each	\$ _____	\$ _____
15	202	Removal of Concrete Ditch (Existing Concrete is about 2-3 Inches Thick)	630.	Lin. Ft.	\$ _____	\$ _____
16	202	Removal of Asphalt Mat (Full-Depth)	71.	Sq. Yd.	\$ _____	\$ _____
17	202	Removal of Existing Pipe (Size as Shown on the Plans)	260.	Lin. Ft.	\$ _____	\$ _____
18	202	Remove Existing Irrigation Structures (Concrete)	2.	Each	\$ _____	\$ _____
19	202	Removal of Tree	1.	Each	\$ _____	\$ _____
20	202	Removal of Concrete (Includes, but not limited to, curb, gutter, sidewalk, driveway, slabs, V-pans, curb ramps, intersection corners, aprons, landscape borders, and concrete walls)	11.	Sq. Yd.	\$ _____	\$ _____
21	202	Removal of Fence (5-ft Tall Chain-Link)	320.	Lin. Ft.	\$ _____	\$ _____

Bid Schedule: 2021 G Road Irrigation Modification Project

Item No.	CDOT, City Ref.	Description	Quantity	Units	Unit Price	Total Price
22	210	Adjust Existing Water Service Pipe (Property 2426 G Road) (Cost of Adjusting Existing Water Service pipe shall be included in the Cost of the Irrigation Pipe and shall include all necessary fittings and pipe required to adjust/relocate water service) (The water service is assumed to be 3/4" dia. Copper service pipe)	1.	Lump Sum	\$ _____	\$ _____
23	210	Reset Sign	3.	Each	\$ _____	\$ _____
24	210	Reset Gate (Chain-Link Gate) (Attached existing gate to the proposed new chain-link fence)	2.	Each	\$ _____	\$ _____
25	210	Reset Landscape Groundcover (Cobble Rock) (Match in Kind)	1.	Lump Sum	\$ _____	\$ _____
26	304	Aggregate Base Course (Class 6) (8" thick) (Concrete Sidewalk)	11.	Sq. Yd.	\$ _____	\$ _____
27	304	Aggregate Base Course (Class 6) (15" thick) (G Road)	71.	Sq. Yd.	\$ _____	\$ _____
28	304	Washed Rock Surface Course for Gravel Driveways (Match Existing Surface Rock as closely as possible) (2" - 3" Thick)	85.	Sq. Yd.	\$ _____	\$ _____
29	401	Cold Mix Asphalt (Temporary Patching) (2" Thick) (To be used on G Road between Stationing 1+21 to 1+62)	80.	Sq. Yd.	\$ _____	\$ _____
30	401	Hot Bituminous Pavement (Patching) (5" Thick) (Grading SX, PG 64-22) (GYR.=75) (One 3" Lift and One 2" Lift)	80.	Sq. Yd.	\$ _____	\$ _____
31	407	Emulsified Asphalt (Tack Coat)	7.	Gallon	\$ _____	\$ _____
32	607	Chain-Link Fence (5' High) (Galvanized) (10' Wide Post Spacing, Typ.)	320.	Lin. Ft.	\$ _____	\$ _____
33	608	Monolithic Vertical Curb, Gutter, and Sidewalk (7-ft wide)	11.	Sq. Yd.	\$ _____	\$ _____
34	620	Portable Sanitary Facility	1.	Each	\$ _____	\$ _____
35	625	Construction Surveying (Includes As-Built Drawings)	1.	Lump Sum	\$ _____	\$ _____
36	626	Mobilization	1.	Lump Sum	\$ _____	\$ _____
37	630	Traffic Control Plan	1.	Lump Sum	\$ _____	\$ _____

Bid Schedule: 2021 G Road Irrigation Modification Project

Item No.	CDOT, City Ref.	Description	Quantity	Units	Unit Price	Total Price
38	630	Traffic Control (Complete in Place)	1.	Lump Sum	\$ _____	\$ _____
39	630	Flagging	500.	Hour	\$ _____	\$ _____
MCR		Minor Contract Revisions	---	---	---	\$ <u>12,000.00</u>
Bid Amount:						\$ _____

Bid Amount:

_____ **dollars**

Contractor Name:
Contractor Address:
Contractor Phone #:

The undersigned Bidder proposes to subcontract the following portion of Work:

<u>Name & address of Sub-Contractor</u>	<u>Description of work to be performed</u>	<u>% of Contract</u>
_____	_____	_____
_____	_____	_____
_____	_____	_____
_____	_____	_____

The undersigned Bidder acknowledges the right of the City to reject any and all Bids submitted and to waive informalities and irregularities therein in the City's sole discretion.

By submission of the Bid, each Bidder certifies, and in the case of a joint Bid each party thereto certifies as to his own organization, that this Bid has been arrived at independently, without collusion, consultation, communication, or agreement as to any matter relating to this Bid with any other Bidder or with any competitor.

Appendix A

Project Submittal Form

PROJECT SUBMITTAL FORM

PROJECT: 2021 G Road Irrigation Modification Project

CONTRACTOR:

PROJECT ENGINEER: Lee Cooper

Description	Date Received	Resubmittal Requested	Resubmittal Received	Date Accepted
CONSTRUCTION				
Irrigation Pipe (18" Corrugated HDPE Pipe by ADS Dual-Wall N-12 Watertight Pipe)				
Imported Trench Backfill				
Slide Gates				
Irrigation Structures				
Aluminum Bar Grating				
Pipe Bedding Material, Type A				
Aggregate Base Course, Class 6				
Hot Bituminous Pavement Mix Design				
Construction Schedule				

Appendix B

Project Special Provisions

CITY OF GRAND JUNCTION
DEPARTMENT OF PUBLIC WORKS AND UTILITIES
ENGINEERING DIVISION

2021 G Road Irrigation Modification Project

SPECIAL PROVISIONS

GENERAL:

The descriptions of the pay items listed in the Bid Schedule for this Project may not agree with those listed in the Standard Specifications. Payment for all Work performed, as required in the Contract Documents, will be in accordance with the items and units listed in the Bid Schedule.

STANDARD SPECIFICATIONS FOR ROAD AND BRIDGE CONSTRUCTION:

The *City of Grand Junction Standard Specifications for Road and Bridge Construction* are hereby modified or supplemented for this Project by the following modifications to *The Standard Specifications for Road and Bridge Construction*, State Department of Highways, Division of Highways, State of Colorado:

SP-1 SECTION 208 – EROSION CONTROL

Section 208 of the Standard Specifications is hereby revised for this project as follows:

Subsection 208.04 shall include the following:

Any of the materials to be installed or used for the installation of the sewer line shall be stored within the construction area where the Contractor is working unless permission is granted to store materials elsewhere. Any glues and/or adhesives necessary shall be contained at all times within a spill proof and waterproof container when not being used.

All vehicle and equipment maintenance and fueling shall be performed in a designated area within the construction area that will not interfere with roadway traffic operations unless traffic control is provided. The fueling area shall exhibit Best Management Practices in order to minimize and/or eliminate the potential of fuel spillage. Any spillage of fuel onto the ground shall be immediately cleaned up and any contaminated soil disposed of properly at the Mesa County Landfill. Documentation of spills, leaks and overflows that result in the discharge of pollutants, including logging and reporting of the spill is required to the Water Quality Control Division at their toll-free 24-hour environmental emergency spill reporting line – 1-877-518-5608.

The Contractor shall clear the site of all on-site waste daily, including scrap from construction materials.

Concrete trucks will be required to wash out in a portable concrete washout pool supplied by the Contractor or the concrete truck can wait to washout back at the concrete batching facility. The Contractor will be responsible for maintaining the washout pool. The washout pool shall be cleaned out and/or replaced when the washout pool reaches 50% of total capacity. The concrete washout pool needs to be dynamic and durable in its ability to be moved with the progress of construction.

The Contractor shall clear the site of all trash and litter daily. Portable toilets will be maintained (cleaned and emptied) by a local supplier.

SP-2 SECTION 601 – STRUCTURAL CONCRETE

Section 601 of the Standard Specifications is hereby revised for this project as follows:

Delete subsection 601.02 from the City of Grand Junction Standard Specifications and replace with the following:

Concrete for construction of curbs, gutters, sidewalks, irrigation structures, curb ramps, driveway approaches, corner fillets, drainage pans, median cover, and trails shall be CDOT Class D concrete per the 2017 CDOT Standard Specifications for Road and Bridge Construction (Red Book).

- Minimum field compressive strength: 4,500 psi at 28 days
- Air Content: 6% +/- 1.5%
- Maximum water cement ratio: 0.45
- Maximum slump at delivery shall be 4-inches. In the event that the concrete slump from the first truck of the day exceeds 5-inches the load will be rejected. Subsequent batches shall be adjusted so that the slump at delivery does not exceed 4-inches.

STANDARD SPECIFICATIONS FOR CONSTRUCTION OF WATER LINES, SANITARY SEWERS, STORM DRAINS, UNDERDRAINS AND IRRIGATION SYSTEMS

The City of Grand Junction *Standard Specifications for Construction of Water Lines, Sanitary Sewers, Storm Drains, Underdrains and Irrigation Systems* are hereby modified for this Project as follows:

SP-4 SECTION 103 – REMOVALS, EXCAVATION, BACKFILLING AND RESTORATION

Section 103 of the Standard Specification is hereby revised for this project as follows:

Subsection 103.16, Earth Backfill Material, shall include the following:

Native material excavated on site shall be used for backfill on all pipelines and appurtenances above the bedding and haunching material unless the native material is too wet and/or otherwise unsuitable for backfill as determined by the Project Engineer or the Project Inspector. In such case, imported trench backfill material, or other approved material, shall be used and paid for per ton of material supplied, placed and compacted. The Contractor will be required to salvage useable materials from the project excavations and mix the useable material with imported trench backfill prior to placing backfill in the trench. The contract price for "Imported Trench Backfill" shall include the disposal of the unsuitable material.

CITY OF GRAND JUNCTION 2021 G ROAD IRRIGATION MODIFICATION PROJECT January 27, 2021



PROJECT LOCATION

Sheet Index

- 1 Cover Sheet
- 2 Standard Abbreviations, Legend, & Symbols
- 3 Summary of Approximate Quantities
- 4 Project Control Map
- 5-11 Subsurface Utility Engineering Plan
- 12-13 Irrigation Details
- 14-17 Irrigation Plan & Profiles

VICINITY MAP



*Public Works
Engineering Division*

NOTE: NOTIFY AFFECTED UTILITY VENDOR 48 HOURS PRIOR TO EXCAVATIONS THAT WILL EXPOSE UTILITY LINES. THE COVER SHEET WILL HAVE A LISTING OF UTILITY VENDORS AND TELEPHONE NUMBERS.

REVISION	DESCRIPTION	DATE
REVISION A REV 1		DATE
REVISION A REV 2		DATE
REVISION A REV 3		DATE
REVISION A REV 4		DATE



Know what's below.
Call before you dig.

Bid Schedule: 2021 G Road Irrigation Modification Project

Item No.	CDOT, City Ref.	Description	Quantity	Units
1	108.2	8" Plastic Starter Coupler (Gasket x Spigot) (8" O.D.) (For use in the Rectangular Box Structure #147)	1	Each
2	108.2	10" Irrigation Pipe (AWWA C-900, DR-18) (Structure #23 Water Drain Pipe to Leach Creek)	25	Lin. Ft.
3	108.2	10" Irrigation Pipe (CMP) (Galvanized CMP at Structure #23) (Includes cost of connection into existing CMP pipe that crosses Leach Creek)	10	Lin. Ft.
4	108.2	12" Irrigation Pipe (AWWA C-900, DR-18) (Includes Type A Bedding and Haunching Material and Backfill of Trench with Native Materials meeting 103.16 Earth Backfill Material)	80	Lin. Ft.
5	108.2	18" Irrigation Pipe (RCP) (Includes Cost of Connection to Existing RCP pipe and Type A Bedding and Haunching Material and Backfill of Trench with Native Materials meeting 103.16 Earth Backfill Material)	10	Lin. Ft.
6	108.2	18" Irrigation Pipe (HDPE) (Corrugated HDPE ADS N-12 Dual-Wall, Water Tight (WTIB) Pipe or Engineer Approved Equal) (20-ft Pipe Lengths) (Includes Type A Bedding and Haunching Material and Backfill of Trench with Native Materials meeting 103.16 Earth Backfill Material)	710	Lin. Ft.
7	108.2	18" Double Wide Field Repair Coupler by ADS or Project Engineer Approved Equal (Use for Connecting new 18" HDPE pipe to Existing 18" HDPE Pipe) (Includes Pouring a Concrete Collar around Repair Coupler for added support)	2	Each
8	108.2	Imported Trench Backfill (Class 3) (Includes haul and disposal of unsuitable excavated material) (Assumed material unit weight = 133 lbs/ft ³)	40	Ton
9	108.2	Imported Trench Backfill (Clean Fill Dirt) (Clean Fill Dirt shall be used where there isn't enough native material available to backfill new irrigation pipe trench) (Anticipated for use between Pipe Stations 1+78 to 14+35)	250	Cu. Yd.
10	108.5	Irrigation Basic Manhole (36" I.D.) (Includes Concrete Lid Slab with Cast-in-Flush Inverted Aluminum Ring and Cover with the word "Irrigation" Cast into the Cover)	2	Each

Item No.	CDOT, City Ref.	Description	Quantity	Units
11	108.5	Irrigation Basic Manhole (48" I.D.) (Includes Concrete Lid Slab with Cast-in-Flush Inverted Aluminum Ring and Cover with the word "Irrigation" Cast into the Cover)	1	Each
12	108.5	Irrigation Structure Manhole (48" I.D.) (See Structure #23 Details) (Includes Fresno Series 5500 Galvanized Toggle Gates (3 Total) or Engineer Approved Equal, and Aluminum Bar Grating and Locking Bar Assembly as shown in detail)	1	Each
13	108.5	Manhole Barrel Section (48" I.D.) (D>5')	4	Vert. Ft.
14	108.5	Rectangular Irrigation Structure (24" x 36") (Large Area Inlet Box with Aluminum Bar Grating per Structure #147 Detail) (See City Std. Detail D-10 for Concrete Box Details)	1	Each
15	202	Removal of Concrete Ditch (Existing Concrete is about 2-3 Inches Thick)	630	Lin. Ft.
16	202	Removal of Asphalt Mat (Full-Depth)	71	Sq. Yd.
17	202	Removal of Existing Pipe (Size as Shown on the Plans)	260	Lin. Ft.
18	202	Remove Existing Irrigation Structures (Concrete)	2	Each
19	202	Removal of Tree	1	Each
20	202	Removal of Concrete (Includes, but not limited to, curb, gutter, sidewalk, driveway, slabs, V-pans, curb ramps, intersection corners, aprons, landscape borders, and concrete walls)	11	Sq. Yd.
21	202	Removal of Fence (5-ft Tall Chain-Link)	320	Lin. Ft.
22	210	Adjust Existing Water Service Pipe (Property 2426 G Road) (Cost of Adjusting Existing Water Service pipe shall be included in the Cost of the Irrigation Pipe and shall include all necessary fittings and pipe required to adjust/relocate water service) (The water service is assumed to be 3/4" dia. Copper service pipe)	1	Lump Sum
23	210	Reset Sign	3	Each
24	210	Reset Gate (Chain-Link Gate) (Attached existing gate to the proposed new chain-link fence)	2	Each
25	210	Reset Landscape Groundcover (Cobble Rock) (Match in Kind)	1	Lump Sum

Item No.	CDOT, City Ref.	Description	Quantity	Units
26	304	Aggregate Base Course (Class 6) (8" thick) (Concrete Sidewalk)	11	Sq. Yd.
27	304	Aggregate Base Course (Class 6) (15" thick) (G Road)	71	Sq. Yd.
28	304	Washed Rock Surface Course for Gravel Driveways (Match Existing Surface Rock as closely as possible) (2" - 3" Thick)	85	Sq. Yd.
29	401	Cold Mix Asphalt (Temporary Patching) (2" Thick) (To be used on G Road between Stationing 1+21 to 1+62)	80	Sq. Yd.
30	401	Hot Bituminous Pavement (Patching) (5" Thick) (Grading SX, PG 64-22) (GYR.=75) (One 3" Lift and One 2" Lift)	80	Sq. Yd.
31	407	Emulsified Asphalt (Tack Coat)	7	Gallon
32	607	Chain-Link Fence (5' High) (Galvanized) (10' Wide Post Spacing, Typ.)	320	Lin. Ft.
33	608	Monolithic Vertical Curb, Gutter, and Sidewalk (7-ft wide)	11	Sq. Yd.
34	620	Portable Sanitary Facility	1	Each
35	625	Construction Surveying (Includes As-Built Drawings)	1	Lump Sum
36	626	Mobilization	1	Lump Sum
37	630	Traffic Control Plan	1	Lump Sum
38	630	Traffic Control (Complete in Place)	1	Lump Sum
39	630	Flagging	500	Hour

REVISION Δ REV 1	DESCRIPTION	DATE	DRAWN BY JCS	DATE 2021
REVISION Δ REV 2			DESIGNED BY JCS	DATE 2021
REVISION Δ REV 3			CHECKED BY ALC	DATE 2021
REVISION Δ REV 4			APPROVED BY JCP	DATE 2021

NO SCALE



PUBLIC WORKS
ENGINEERING DIVISION
PROJECT NO. 207-F2109

2021 G ROAD IRRIGATION MODIFICATION
PROJECT
SUMMARY OF APPROXIMATE QUANTITIES

GENERAL NOTES:

- 1 PURPOSE: TO SEARCH, INTERPRET, AND DEPICT SPECIFIC EXISTING UNDERGROUND UTILITIES AS PER THE SCOPE OF WORK FOR THE 24 ROAD AND G ROAD PROJECT.
- 2 THE SUBSURFACE UTILITIES SHOWN ON THE SUBSURFACE UTILITY INVESTIGATION WERE IDENTIFIED USING APPROPRIATE INDUSTRY STANDARD DETECTION METHODOLOGIES IN ACCORDANCE WITH THE AMERICAN SOCIETY OF CIVIL ENGINEERS (ASCE) STANDARD GUIDELINE FOR THE COLLECTION AND DEPICTION OF EXISTING SUBSURFACE UTILITY DATA. QUALITY LEVELS AND DEFINITIONS PER CI/ASCE STANDARD NO. 38.
- 3 QUALITY LEVEL "D" – QL-D – DEPICTED ACCORDING TO UTILITY RECORD INFORMATION AND IN-FIELD VISUAL INSPECTION. NO ELECTRONIC DESIGNATING INFORMATION WAS OBTAINED. UTILITIES WITH A QL-D LABEL ARE DEPICTED ON THE PLANS USING PROFESSIONAL JUDGMENT IN INTERPRETING THIRD-PARTY RECORDS OR OTHER INFORMATION.
- 4 QUALITY LEVEL "C" – QL-C – EXISTING UTILITY STRUCTURES HAVE BEEN FIELD LOCATED AND SURVEYED TO ASSIST IN THE DEPICTING OF THE UTILITIES SHOWN ON THE RECORDS. NO ELECTRONIC DESIGNATING INFORMATION WAS OBTAINED. UTILITIES WITH A QL-C LABEL ARE DEPICTED ON THE PLANS USING PROFESSIONAL JUDGMENT IN INTERPRETING AND CORRELATING THE SURVEYED UTILITY APPURTENANCES, WITH THIRD-PARTY RECORDS INFORMATION.
- 5 QUALITY LEVEL "B" – QL-B – INFORMATION WAS OBTAINED THROUGH THE APPLICATION OF APPROPRIATE SURFACE GEOPHYSICAL METHODS TO DETERMINE THE EXISTENCE AND APPROXIMATE HORIZONTAL POSITION OF THE SUBSURFACE UTILITIES. QL-B DATA SHOULD BE REPRODUCIBLE BY SURFACE GEOPHYSICS AT ANY POINT OF THEIR DEPICTION. ALL UTILITIES ARE QL-B UNLESS OTHERWISE NOTED, THEY ARE DEPICTED ON THE PLANS USING PROFESSIONAL JUDGMENT IN SELECTING AND INTERPRETING APPROPRIATE GEOPHYSICAL DATA, SURVEYING TO APPROPRIATE PROJECT ACCURACIES, AND USING JUDGMENT TO CORRELATE THIRD-PARTY RECORDS OR OTHER INFORMATION, IF AVAILABLE, TO THESE QL-B DEPICTIONS.
- 6 QUALITY LEVEL "A" – QL-A – OBTAIN PRECISE HORIZONTAL AND VERTICAL POSITION OF THE UTILITY LINE BY EXCAVATING A TEST HOLE. THE TEST HOLE SHALL BE DONE USING VACUUM EXCAVATION OR COMPARABLE NON-DESTRUCTIVE EQUIPMENT IN A MANNER AS TO CAUSE NO DAMAGE TO UTILITY LINE.
- 7 RELIANCE UPON SUBSURFACE UTILITY DATA FOR RISK MANAGEMENT PURPOSES DURING BIDDING DOES NOT RELIEVE THE EXCAVATOR OR UTILITY OWNER FROM FOLLOWING ALL APPLICABLE UTILITY DAMAGE PREVENTION STATUTES, POLICIES, AND/OR PROCEDURES DURING EXCAVATION.
- 8 IT IS IMPORTANT THAT THE CONTRACTOR INVESTIGATES AND UNDERSTANDS THE SCOPE OF WORK AND LIMITS OF THE UTILITY INVESTIGATIONS LEADING TO THESE UTILITY DEPICTIONS.
- 9 UTILITY SIZE AND TYPE ARE DETERMINED THROUGH AVAILABLE UTILITY OWNER INFORMATION OR FIELD OBSERVATIONS; UTILITIES LABELED AS UNKNOWN HAVE NO CORRELATED RECORDS OR VISIBLE APPURTENANCES TO DETERMINE FUNCTION OR TYPE.
- 10 UTILITY MAPPING WAS COMPLETED IN THE FIELD ON 6/18/2020. UTILITIES MAY HAVE BEEN CHANGED OR ADDED AFTER THIS DATE.
- 11 "END OF INFORMATION" (EOI) SIGNIFIES GEOPHYSICAL EQUIPMENT LOST THE SIGNAL OF THE TARGET UTILITY AND THE LINE WAS UNABLE TO BE DESIGNATED ANY FURTHER. LINES MAY CONTINUE ON OR MAY STOP. POSITIVE VERIFICATION BY EXCAVATION IS REQUIRED TO CONFIRM PRESENCE BEYOND END OF SIGNAL.
- 12 THE FOLLOWING EQUIPMENT WAS USED IN THE UTILITY INVESTIGATION: VM-810 METROTECH UTILITY LINE LOCATOR, TRIMBLE GPS SURVEY CONTROL AND/OR TOTAL STATION.
- 13 HORIZONTAL COORDINATE SYSTEM: PROJECT COORDINATES ARE BASED ON MESA COUNTY LOCAL COORDINATE SYSTEM, MCLS ZONE GVA.
- 14 VERTICAL DATUM: WGS 1984
- 15 SEE THE STANDARD ABBREVIATIONS, LEGENDS, AND SYMBOLS FOR UTILITY LINE LINE TYPE DEPICTIONS, UTILITY APPURTENANCES SYMBOLS, AND ABBREVIATIONS USED FOR THE SUBSURFACE UTILITY ENGINEERING PLAN.
- 16 THE FOLLOWING COMPANIES HAVE NOT SUPPLIED RECORDS AS OF 11/05/2020: CHARTER CABLE
- 17 THE OWNERS WITHIN THE PROJECT LIMITS ARE LISTED IN THE TABLE BELOW BUT MAY NOT BE LIMITED TO THOSE LISTED IN THE TABLE.

UTILITIES AND AGENCIES								
AGENCY	NAME	POSITION	ROLE	MAILING ADDRESS	STREET ADDRESS	CITY, STATE	VOICE-WK	FAX
CITY OF GRAND JUNCTION	LEE COOPER	PROJECT ENGINEER	SANITARY SEWER	333 WEST AVE BLDG C	333 WEST AVE BLDG C	GRAND JCT., CO 81501	(970) 256-4155	(970) 256-4022
CITY OF GRAND JUNCTION	TOM LANAM	TRAFFIC SUPERVISOR	TRAFFIC	333 WEST AVE BLDG D	333 WEST AVE BLDG D	GRAND JCT., CO 81501	(970) 244-1573	(970) 256-4022
GRAND VALLEY IRRIGATION COMPANY	PHIL BERTRAND	IRRIGATION SUPERINTENDENT	IRRIGATION	988 26 RD	988 26 RD	GRAND JCT., CO 81506	(970) 242-2782	
SPECTRUM	MARK KOSTELECKY	MANAGER	CABLE TV	2502 FORESIGHT CIRCLE	2502 FORESIGHT CIRCLE	GRAND JCT., CO 81504	(970) 245-8750	(970) 245-6803
CENTURYLINK	CHRIS JOHNSON	ENGINEER	TELEPHONE	2524 BLICHMANN AVE	2524 BLICHMANN AVE	GRAND JCT., CO 81504	(970) 244-4311	(970) 240-4349
UTE WATER	JUSTIN BATES	SUPERVISOR	WATER	PO BOX 460	2190 H ¼ RD	GRAND JCT., CO 81502	(970) 242-7491	(970) 242-9189
XCEL	BRENDA BOES	UNIT MANAGER	ELECTRIC	2538 BLICHMANN AVE	2538 BLICHMANN AVE	GRAND JCT., CO 81506	(970) 244-2664	(970) 244-2664
XCEL	SARAH DARRICAU	UNIT MANAGER	GAS	2538 BLICHMANN AVE	2538 BLICHMANN AVE	GRAND JCT., CO 81506	(970) 244-2656	(970) 244-2656
GRAND VALLEY POWER	MIKE GARDNER	SUPERVISOR	ELECTRIC	845 22 RD	845 22 RD	GRAND JCT., CO 81505	(970) 242-0040	
UNITE PRIVATE NETWORKS			COMMUNICATION	123 N 7TH ST., #100	123 N 7TH ST., #100	GRAND JCT., CO 81501	(866) 813-3608	

DESCRIPTION	DATE	DRAWN BY	DATE
REVISION Δ REV 1	---	JCS	2021
REVISION Δ REV 2	---	JCS	2021
REVISION Δ REV 3	---	ALC	2021
REVISION Δ REV 4	---	JCP	2021

NO SCALE



PUBLIC WORKS
ENGINEERING DIVISION
PROJECT NO. 207-F2109

2021 G ROAD IRRIGATION MODIFICATION
PROJECT
S.U.E. GENERAL NOTES

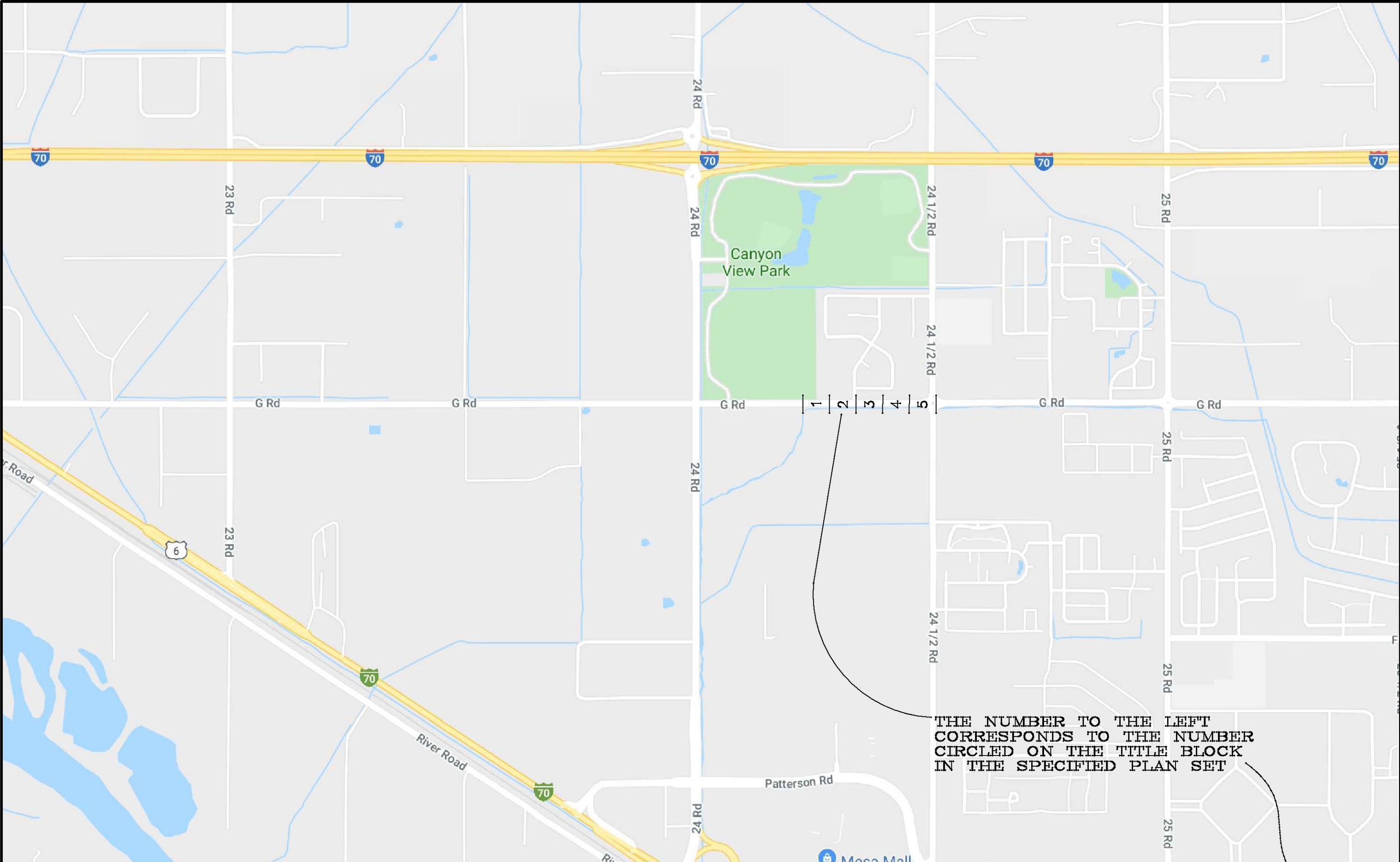

1 | 2 | 3 | 4 | 5

THE NUMBER TO THE LEFT
CORRESPONDS TO THE NUMBER
CIRCLED ON THE TITLE BLOCK
IN THE SPECIFIED PLAN SET

REVISION	DESCRIPTION	DATE	DRAWN BY	DATE
REVISION Δ REV 1			JCS	2021
REVISION Δ REV 2			JCS	2021
REVISION Δ REV 3			ALC	2021
REVISION Δ REV 4			JCP	2021

SCALE



**PUBLIC WORKS
ENGINEERING DIVISION**
PROJECT NO. 207-F2109

**2021 G ROAD IRRIGATION MODIFICATION
PROJECT**
S.U.E. PLAN SHEET INDEX - X

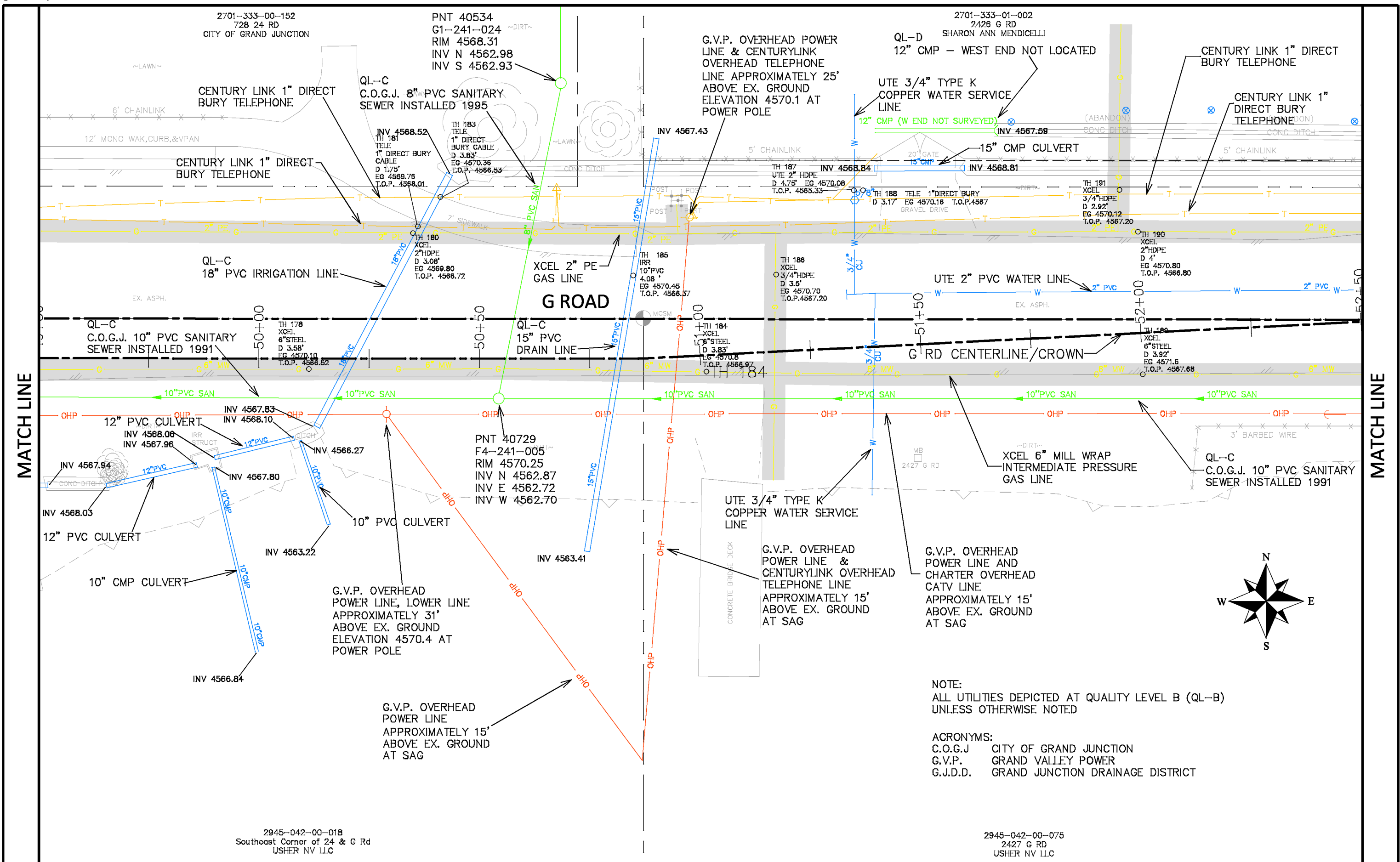

NOTE:
ALL UTILITIES DEPICTED AT QUALITY LEVEL B (QL-B)
UNLESS OTHERWISE NOTED

ACRONYMS:
C.O.G.J. CITY OF GRAND JUNCTION
G.V.P. GRAND VALLEY POWER
G.J.D.D. GRAND JUNCTION DRAINAGE DISTRICT

2945-042-00-018
Southeast Corner of 24 & G Rd
USHER NV LLC

2945-042-00-075
2427 G RD
USHER NV LLC

REVISION	DESCRIPTION	DATE	DRAWN BY	DATE
REV 1			JCS	2021
REV 2			JCS	2021
REV 3			ALC	2021
REV 4			JCP	2021

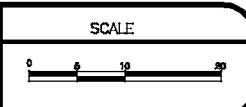

PUBLIC WORKS
ENGINEERING DIVISION
PROJECT NO. 207-F2109

2021 G ROAD IRRIGATION MODIFICATION PROJECT
S.U.E. - 1

N:\Landproj\24 Road and G Road Intersection\dwg\000 IRRIGATION\SUBSURFACE UTILITY ENGINEERING PLAN.dwg, 1/27/2021 3:45:45 PM

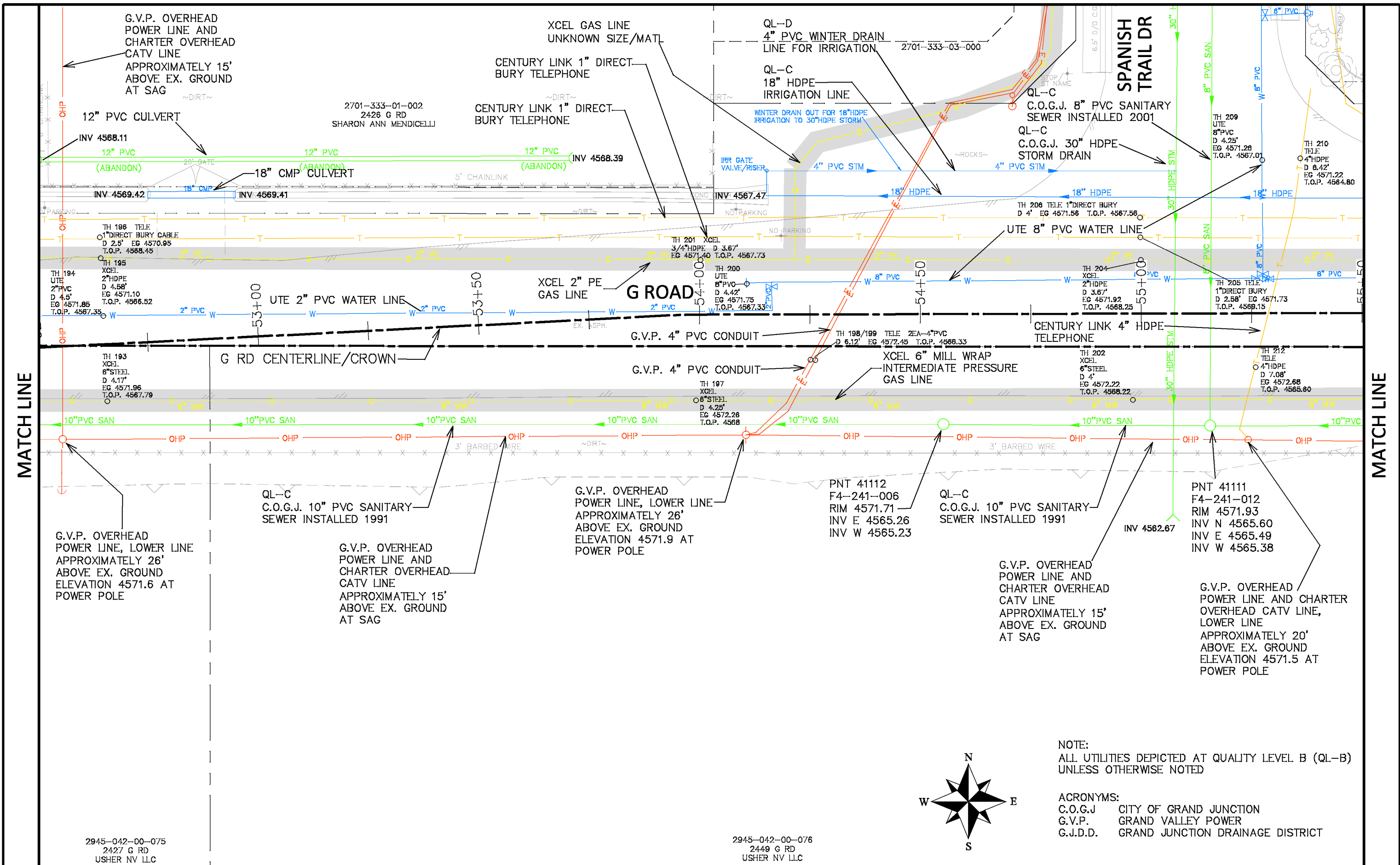

MATCH LINE

MATCH LINE

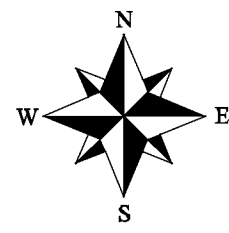

NOTE:
ALL UTILITIES DEPICTED AT QUALITY LEVEL B (QL-B)
UNLESS OTHERWISE NOTED

ACRONYMS:
C.O.G.J. CITY OF GRAND JUNCTION
G.V.P. GRAND VALLEY POWER
G.J.D.D. GRAND JUNCTION DRAINAGE DISTRICT

2945-042-00-075
2427 G RD
USHER NV LLC

2945-042-00-076
2449 G RD
USHER NV LLC

REVISION	DESCRIPTION	DATE
REV 1		
REV 2		
REV 3		
REV 4		

DRAWN BY JCS DATE 2021
DESIGNED BY JCS DATE 2021
CHECKED BY ALC DATE 2021
APPROVED BY JCP DATE 2021

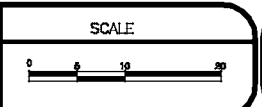

PUBLIC WORKS
ENGINEERING DIVISION
PROJECT NO. 207-F2109

2021 G ROAD IRRIGATION MODIFICATION
PROJECT
S.U.E. - 2

N:\Landproj\24 Road and G Road Intersection\dwg\000 IRRIGATION\SUBSURFACE UTILITY ENGINEERING PLAN.dwg, 1/27/2021 3:45:49 PM

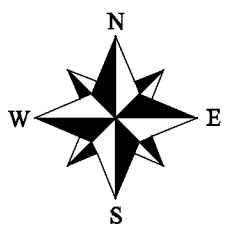
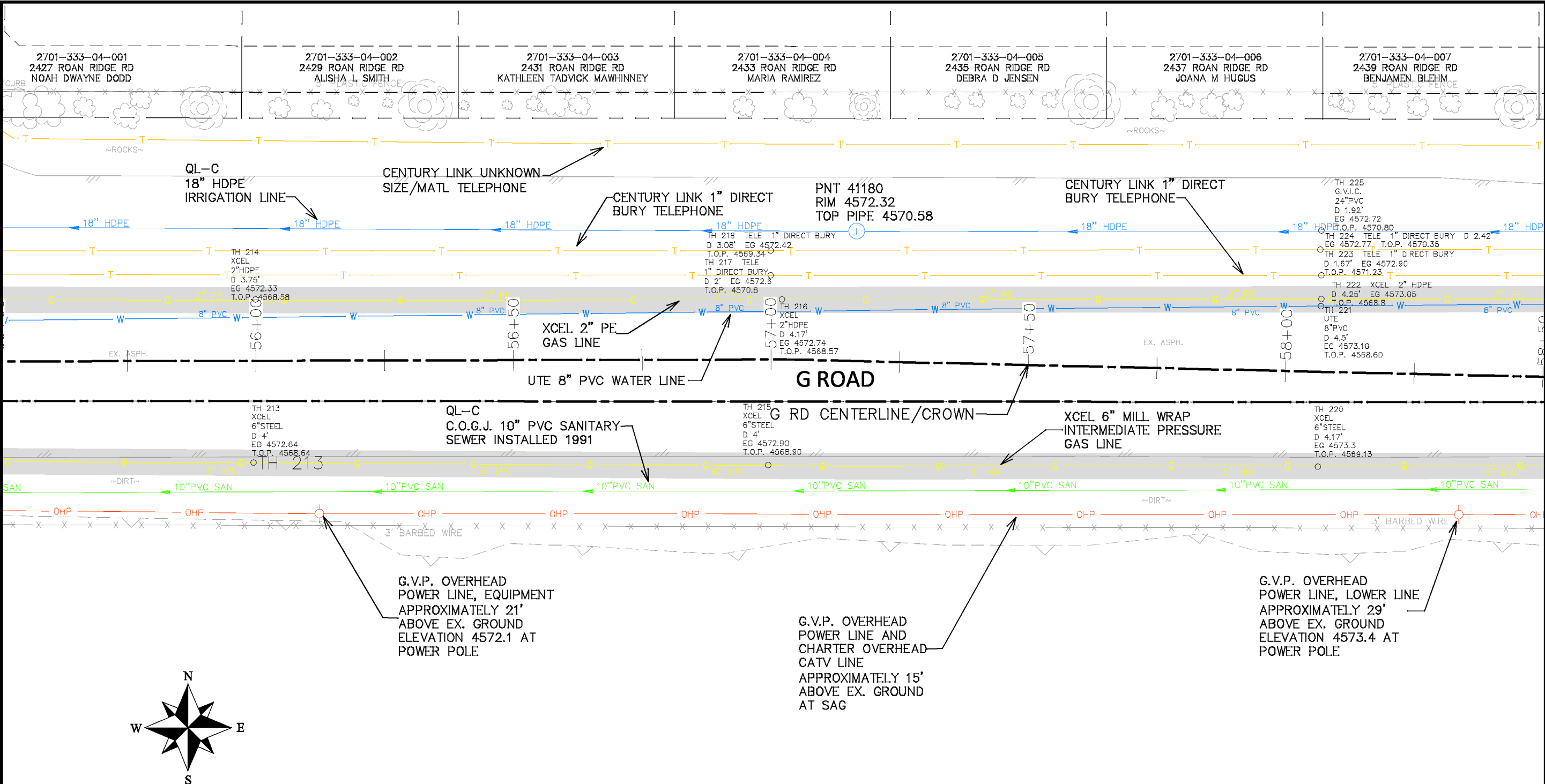

NOTE:
ALL UTILITIES DEPICTED AT QUALITY LEVEL B (QL-B) UNLESS OTHERWISE NOTED

ACRONYMS:
C.O.G.J. CITY OF GRAND JUNCTION
G.V.P. GRAND VALLEY POWER
G.J.D.D. GRAND JUNCTION DRAINAGE DISTRICT

2945-042-00-076
2449 G RD
USHER NV LLC

REVISION	DESCRIPTION	DATE	DRAWN BY	DATE
REV 1			JCS	2021
REV 2			JCS	2021
REV 3			ALC	2021
REV 4			JCP	2021

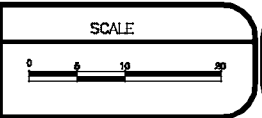

PUBLIC WORKS
ENGINEERING DIVISION
PROJECT NO. 207-F2109

2021 G ROAD IRRIGATION MODIFICATION PROJECT
S.U.E. - 3

N:\Landproj\24 Road and G Road Intersection\dwg\000 IRRIGATION\SUBSURFACE UTILITY ENGINEERING PLAN.dwg, 1/27/2021 3:45:52 PM

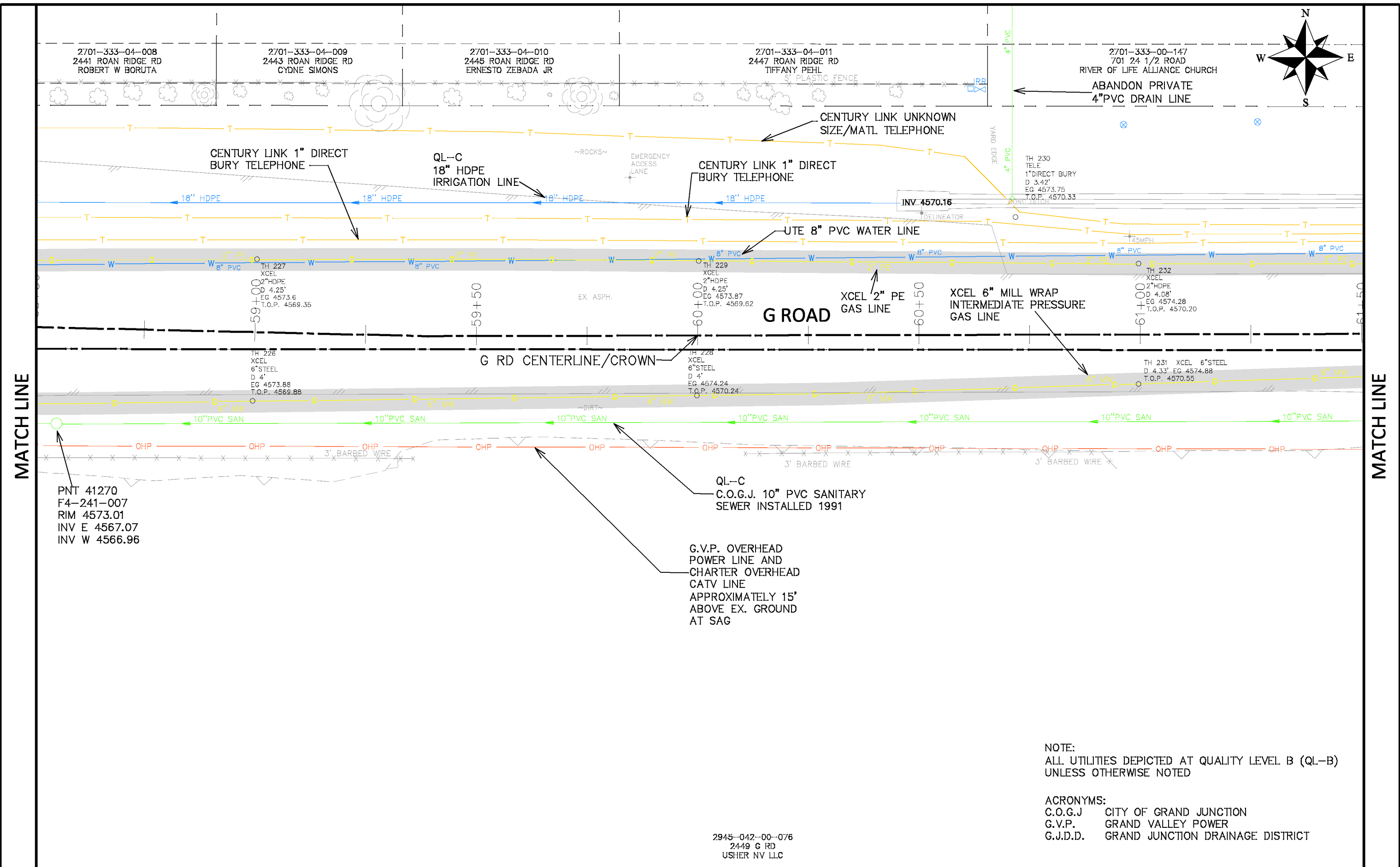
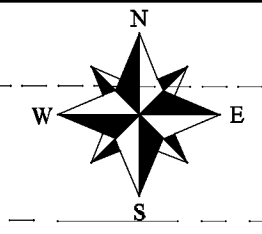

MATCH LINE

MATCH LINE

PNT 41270
F4-241-007
RIM 4573.01
INV E 4567.07
INV W 4566.96

NOTE:
ALL UTILITIES DEPICTED AT QUALITY LEVEL B (QL-B)
UNLESS OTHERWISE NOTED

ACRONYMS:
C.O.G.J. CITY OF GRAND JUNCTION
G.V.P. GRAND VALLEY POWER
G.J.D.D. GRAND JUNCTION DRAINAGE DISTRICT

2945-042-00-076
2449 G RD
USHER NV LLC

REVISION	DESCRIPTION	DATE	DRAWN BY	DATE
REV 1			JCS	2021
REV 2			JCS	2021
REV 3			ALC	2021
REV 4			JCP	2021

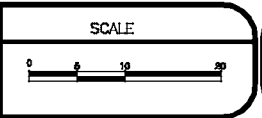

PUBLIC WORKS
ENGINEERING DIVISION
PROJECT NO. 207-F2109

2021 G ROAD IRRIGATION MODIFICATION
PROJECT
S.U.E. - 4

N:\Landproj\24 Road and G Road Intersection\dwg\000 IRRIGATION\SUBSURFACE UTILITY ENGINEERING PLAN.dwg, 1/27/2021 3:45:55 PM

2701-333-00-147
701 24 1/2 ROAD
RIVER OF LIFE ALLIANCE CHURCH

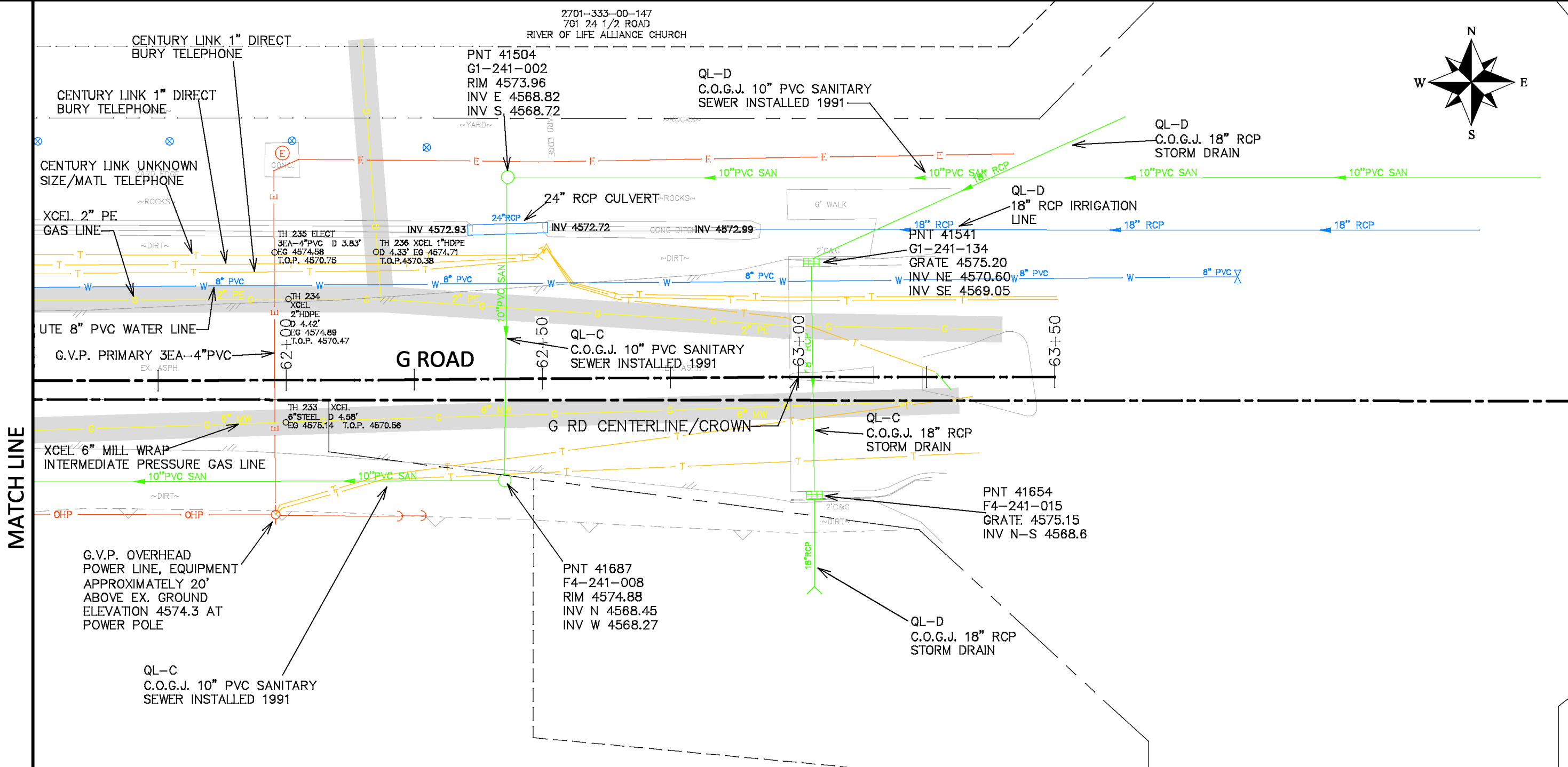
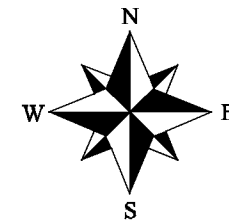

MATCH LINE

MATCH LINE

NOTE:
ALL UTILITIES DEPICTED AT QUALITY LEVEL B (QL-B)
UNLESS OTHERWISE NOTED

ACRONYMS:
C.O.G.J. CITY OF GRAND JUNCTION
G.V.P. GRAND VALLEY POWER
G.J.D.D. GRAND JUNCTION DRAINAGE DISTRICT

2945-042-00-076
2449 G RD
USHER NV LLC

REVISION	DESCRIPTION	DATE	DRAWN BY	DATE
REV 1			JCS	2021
REV 2			JCS	2021
REV 3			ALC	2021
REV 4			JCP	2021

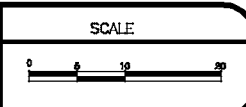

**PUBLIC WORKS
ENGINEERING DIVISION**
PROJECT NO. 207-F2109

**2021 G ROAD IRRIGATION MODIFICATION
PROJECT**
S.U.E. - 5

N:\Landproj\24 Road and G Road Intersection\dwg\000 IRRIGATION\SUBSURFACE UTILITY ENGINEERING PLAN.dwg, 1/27/2021 3:45:58 PM

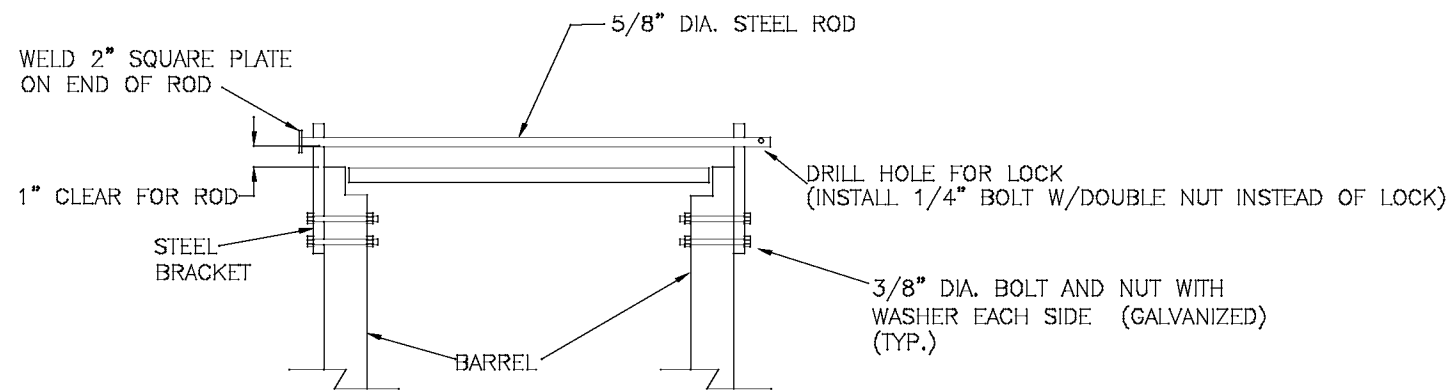
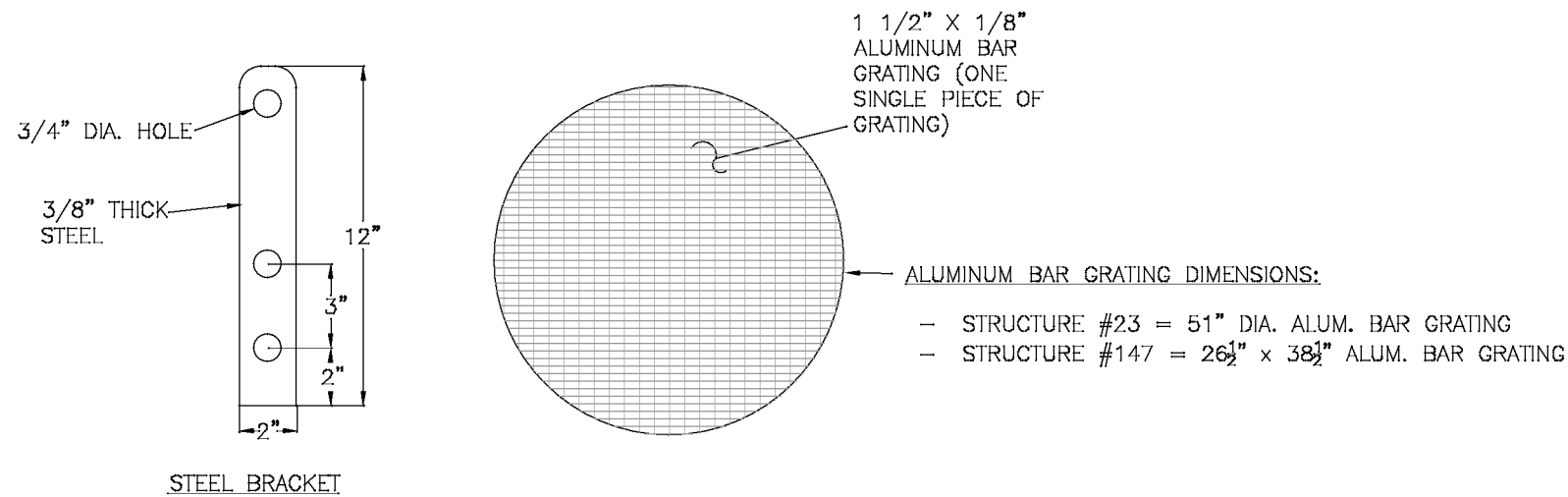

ALUMINUM GRATING AND LOCKING BAR DETAIL FOR IRRIGATION STRUCTURES #23 & #147

NTS

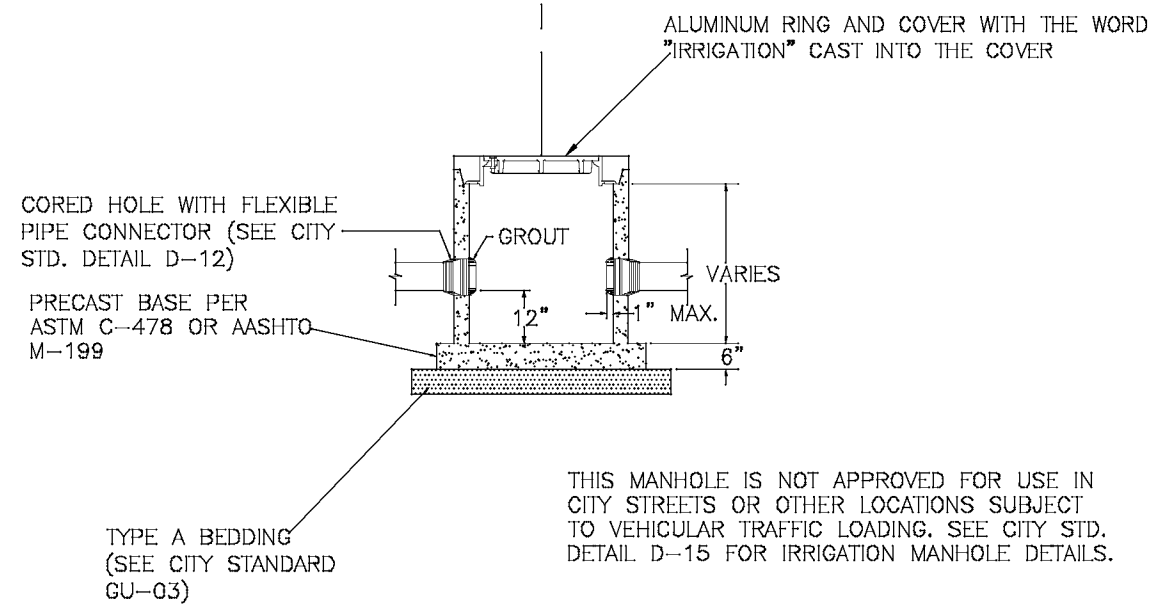
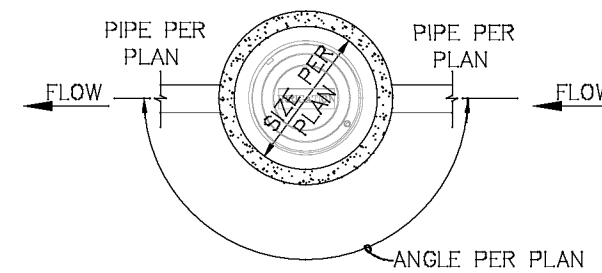

TYPICAL IRRIGATION MANHOLE DETAIL

NTS

REVISION	DESCRIPTION	DATE	DRAWN BY	DATE
REV 1			JCS	2021
REV 2			JCS	2021
REV 3			ALC	2021
REV 4			JCP	2021

SEE PLAN FOR SCALE INFO



PUBLIC WORKS ENGINEERING DIVISION
PROJECT NO. 207-F2109

2021 G ROAD IRRIGATION MODIFICATION PROJECT
IRRIGATION DETAILS - 1

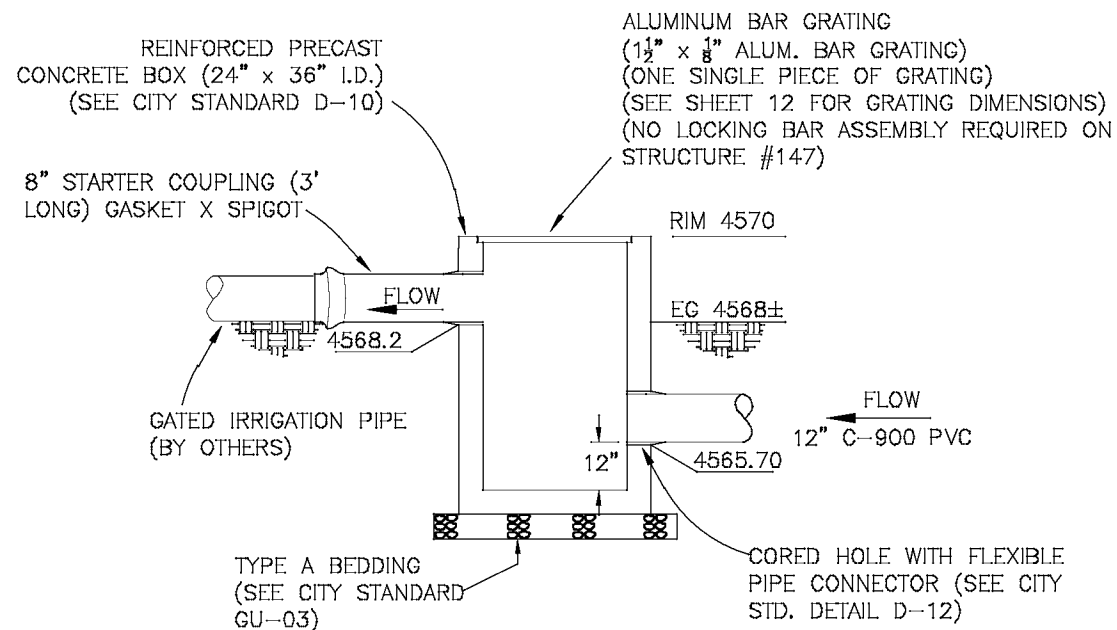

STRUCTURE - (147) IRRIGATION BOX DETAIL

NTS

NOTE:
ALL PIPES THAT HAVE SLIDE GATES ATTACHED TO THEM WILL HAVE A PLASTIC IRRIGATION STARTER PIPE THAT PENETRATES THE MANHOLE SO THAT THE SLIDE GATES CAN BE INSTALLED. JUST OUTSIDE OF THE MANHOLE CONNECT TO PIPE MATERIAL AS PLAN SPECIFIED.

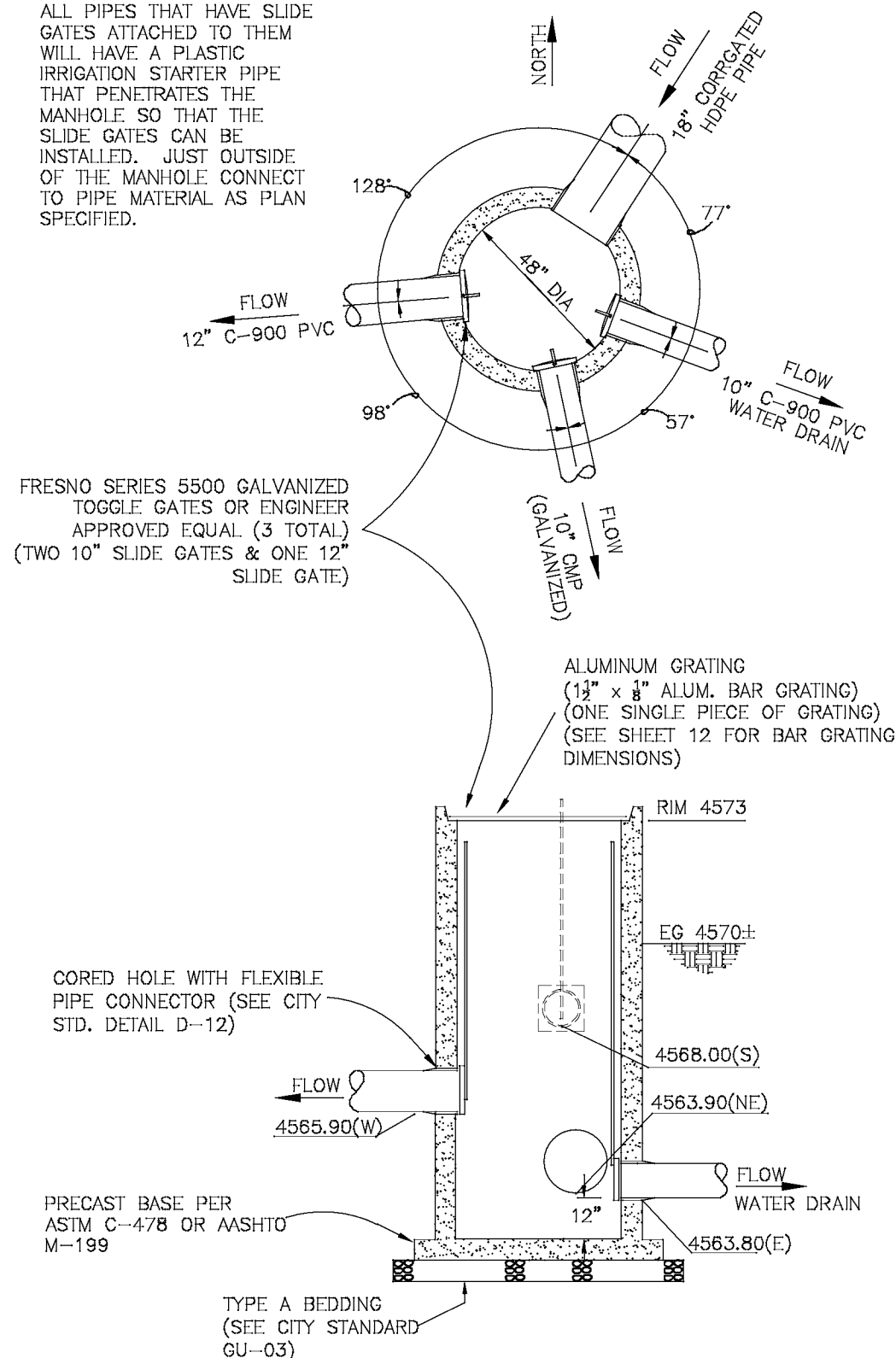

STRUCTURE - (23) IRRIGATION MANHOLE DETAIL

NTS

REVISION	DESCRIPTION	DATE	DRAWN BY	DATE
REV 1			JCS	2021
REV 2			JCS	2021
REV 3			ALC	2021
REV 4			JCP	2021

SEE PLAN FOR SCALE INFO



**PUBLIC WORKS
ENGINEERING DIVISION**
PROJECT NO. 207-F2109

**2021 G ROAD IRRIGATION MODIFICATION
PROJECT**
IRRIGATION DETAILS - 2

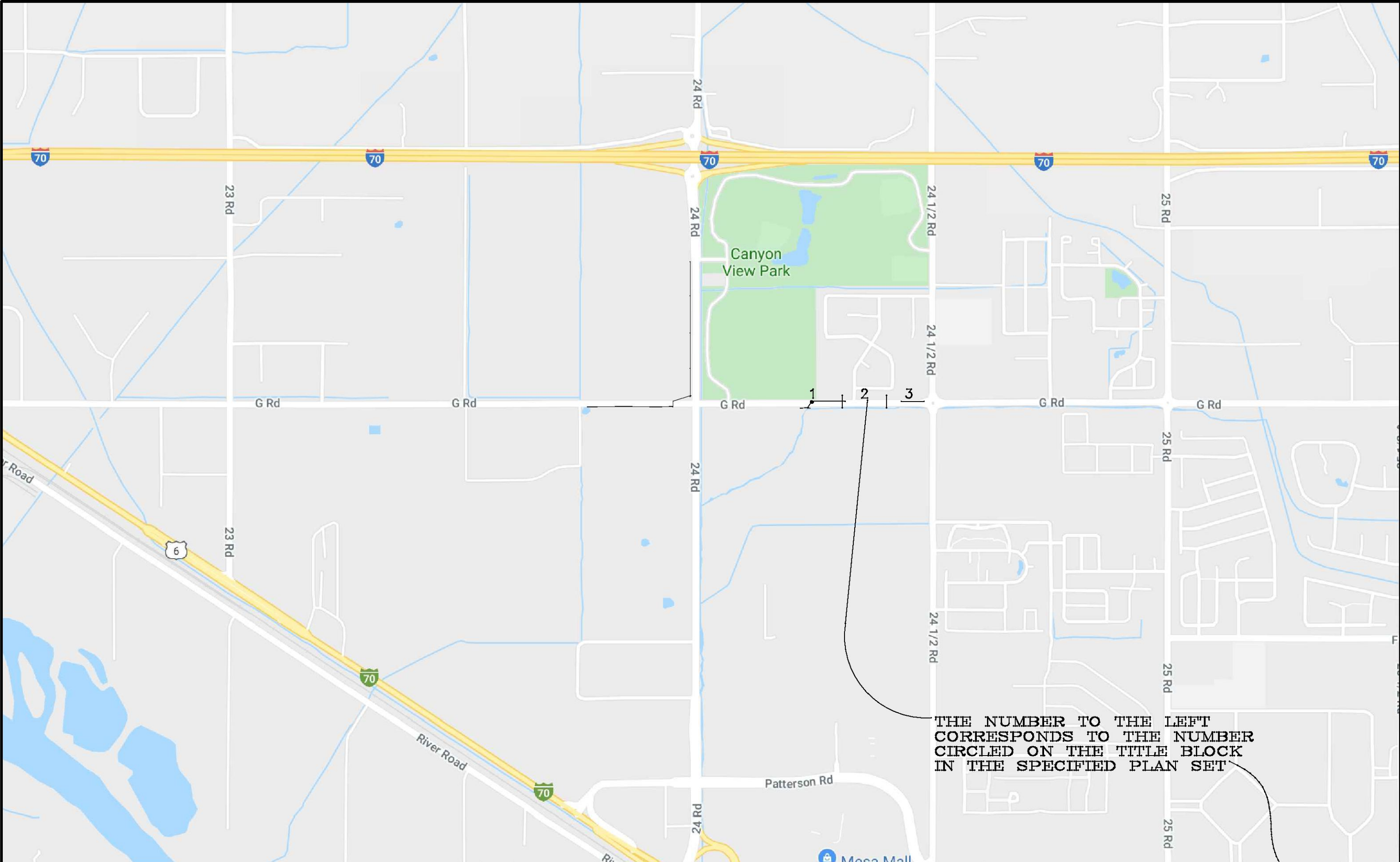

THE NUMBER TO THE LEFT
CORRESPONDS TO THE NUMBER
CIRCLED ON THE TITLE BLOCK
IN THE SPECIFIED PLAN SET

REVISION	DESCRIPTION	DATE	DRAWN BY	DATE
REVISION Δ REV 1			JCS	2021
REVISION Δ REV 2			JCS	2021
REVISION Δ REV 3			ALC	2021
REVISION Δ REV 4			JCP	2021

SCALE



**PUBLIC WORKS
ENGINEERING DIVISION**
PROJECT NO. 207-F2109

**2021 G ROAD IRRIGATION MODIFICATION
PROJECT**
IRRIGATION PLAN SHEET INDEX - **2**

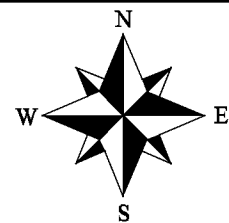

2701-333-00-152
728 24 RD
CITY OF GRAND JUNCTION

2701-333-01-002
2426 G RD
SHARON ANN MENDICELLI

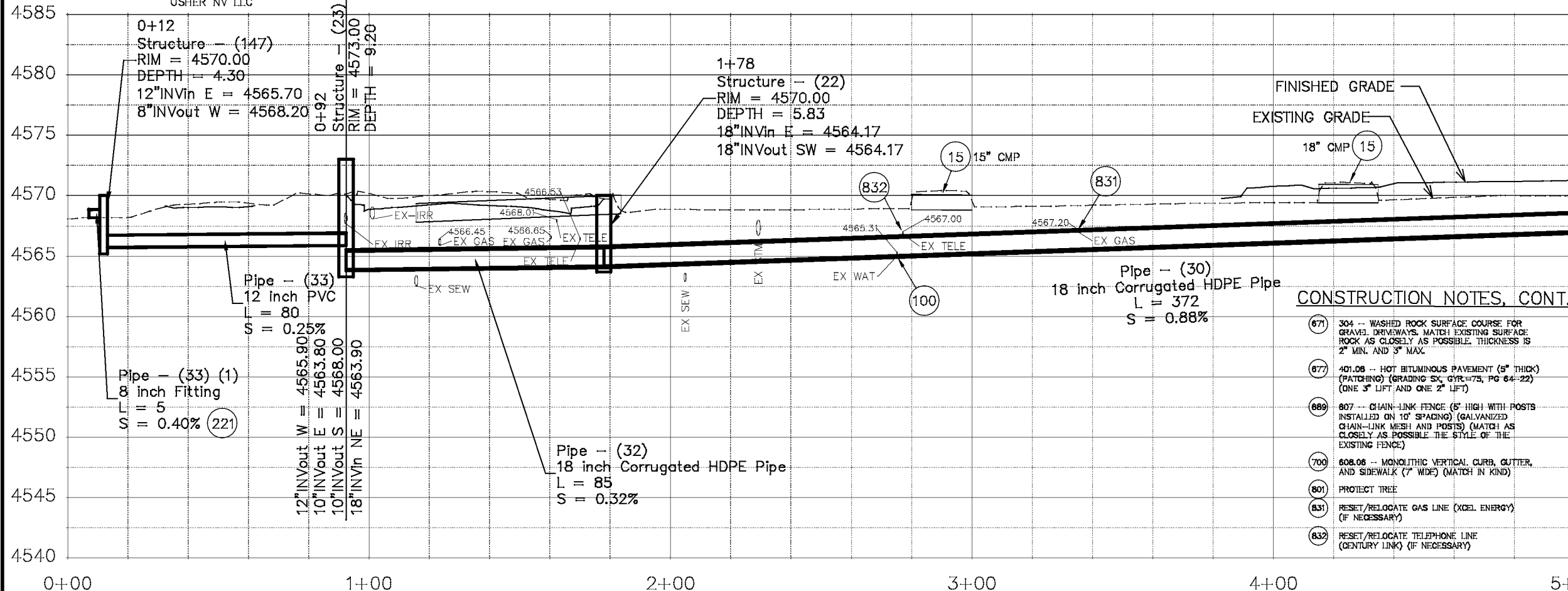
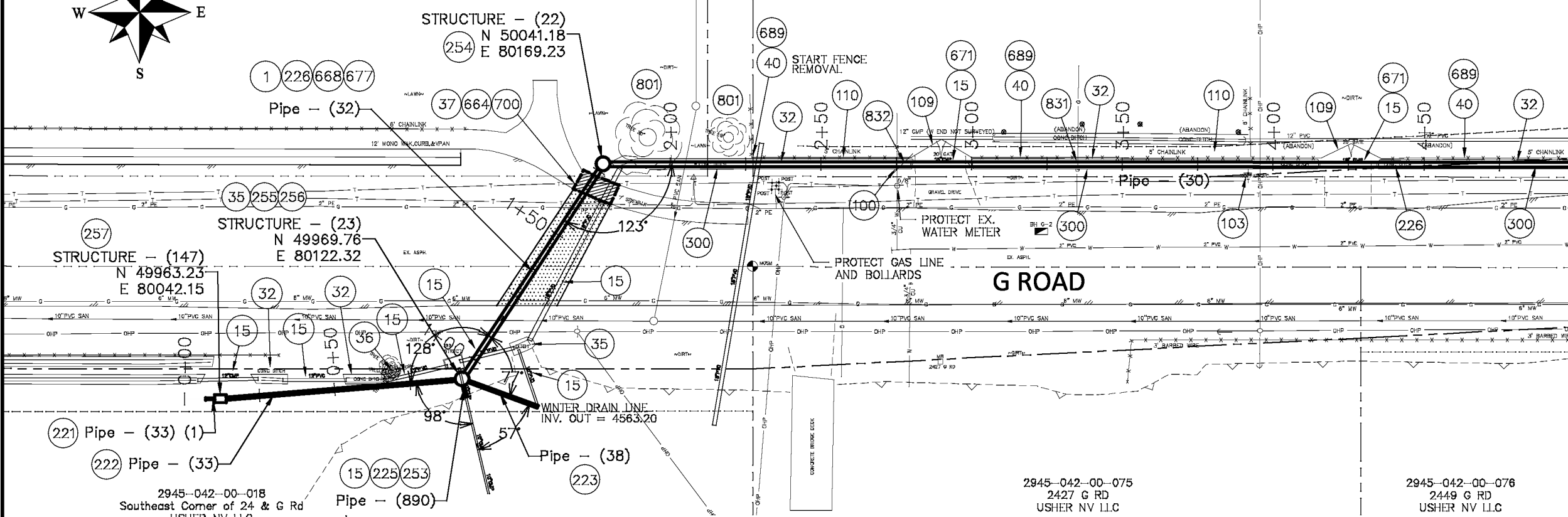

CONSTRUCTION NOTES

- 1 202 -- REMOVAL OF ASPHALT MAT. CUT AND REMOVE ASPHALT AS SHOWN. (INDICATED BY DOT HATCH PATTERN)
- 15 202 -- REMOVAL OF PIPE AS SHOWN. (SIZE AND TYPE AS SHOWN ON PLAN)
- 32 202 -- REMOVAL OF CONCRETE DITCH (2" - 3" THICK CONCRETE)
- 35 202 -- REMOVE EXISTING IRRIGATION STRUCTURE (CONCRETE)
- 36 202 -- REMOVAL OF TREE
- 37 202 -- REMOVE OF CONCRETE (SAW CUT AND REMOVE CONCRETE AS SHOWN) (EXISTING MONOLITHIC CURB, GUTTER, AND SIDEWALK) (REMOVAL DIMENSIONS ARE ABOUT 14" x 7')
- 40 202 -- REMOVAL OF FENCE (5-FT TALL CHAIN-LINK)
- 100 210 -- ADJUST EXISTING WATER SERVICE PIPE TO FACILITATE NEW IRRIGATION PIPE INSTALLATION. (COST OF ADJUSTING WATER SERVICE PIPE SHALL BE INCLUDED IN THE COST OF IRRIGATION PIPE AND SHALL INCLUDE ALL NECESSARY FITTINGS AND PIPE REQUIRED TO ADJUST/RELOCATE EXISTING WATER SERVICE)
- 103 210 -- RESET SIGN
- 106 210 -- RESET GATE (CHAIN-LINK GATE) (CONTRACTOR SHALL CAREFULLY REMOVE EXISTING GATE FOR FUTURE ATTACHMENT TO NEW CHAIN-LINK FENCE)
- 110 210 -- RESET LANDSCAPE GROUND COVER (COBBLE ROCK) (CONTRACTOR SHALL REMOVE GROUND COVER AND ANY UNDERLYING WEED BARRIER AS NEEDED AND STOCKPILE MATERIALS. CONTRACTOR SHALL RESET THESE MATERIALS AND PROVIDE ADDITIONAL MATERIALS AS NEEDED TO RESTORE LANDSCAPING. ANY AND ALL ADDITIONAL MATERIALS ARE INCIDENTAL)
- 221 102.10/108.2 -- 8" PLASTIC STARTER COUPLER (GASKET x SPIGOT) (6" O.D.) (FOR USE IN THE RECTANGULAR IRRIGATION BOX STRUCTURE AT STATION 0+12 FOR GATED IRRIGATION PIPE CONNECTION) (THIS FITTING IS INSTALLED ON THE OUTLET SIDE OF THE IRRIGATION BOX STRUCTURE)
- 222 102.10/108.2 -- 12" IRRIGATION PIPE (AWWA C-900, DR-18) (INCLUDES TYPE A BEDDING AND HAUNCHING MATERIAL AND BACKFILL OF TRENCH WITH NATIVE MATERIALS MEETING 103.16 EARTH BACKFILL MATERIAL)
- 223 102.10/108.2 -- 10" IRRIGATION PIPE (AWWA C-900, DR-18) (STRUCTURE #23 WATER DRAIN PIPE TO LEACH CREEK)
- 225 102.10/108.2 -- 10" IRRIGATION PIPE (CMP) (GALVANIZED CMP AT STRUCTURE #23) (INCLUDES COST OF CONNECTION INTO EXISTING CMP PIPE THAT CROSSES LEACH CREEK)
- 226 102.10/108.2 -- 18" IRRIGATION PIPE (CORRUGATED HDPE ADS N-12 DUAL-WALL, WATER TIGHT (WTB) PIPE OR ENGINEER APPROVED EQUAL) (20-FT PIPE LENGTHS) (INCLUDES TYPE A BEDDING AND HAUNCHING MATERIAL AND BACKFILL OF TRENCH WITH NATIVE MATERIALS MEETING 103.16 EARTH BACKFILL MATERIAL)
- 232 102.12/108.5 -- IRRIGATION BASIC MANHOLE (36" I.D.) (CITY STD. DETAIL D-15) (INCLUDES CONCRETE LID SLAB WITH CAST IN FLUSH INVERTED ALUMINUM RING AND COVER WITH THE WORD "IRRIGATION" CAST INTO THE COVER)
- 233 CONNECT TO EXISTING IRRIGATION PIPE. THE CONTRACT PRICE FOR IRRIGATION PIPE SHALL INCLUDE THE COST OF CONNECTION TO EXISTING PIPELINE.
- 234 102.12/108.5 -- IRRIGATION BASIC MANHOLE (48" I.D.) (CITY STD. DETAIL D-15) (INCLUDES CONCRETE LID SLAB WITH CAST IN FLUSH INVERTED ALUMINUM RING AND COVER WITH THE WORD "IRRIGATION" CAST INTO THE COVER)
- 235 102.12/108.5 -- IRRIGATION STRUCTURE MANHOLE (48" I.D.) (SEE STRUCTURE #23 DETAILS) (INCLUDES FRESNO SERIES 5500 GALVANIZED TOGGLE GATES (3 TOTAL) OR ENGINEER APPROVED EQUAL, AND ALUMINUM BAR GRATING AND LOCKING BAR ASSEMBLY AS SHOWN IN DETAIL)
- 236 102.11/108.5 -- MANHOLE BARREL SECTION (D>6") (48" I.D.)
- 237 102.12/108.5 -- RECTANGULAR IRRIGATION STRUCTURE (24" x 36" I.D.) (LARGE AREA INLET BOX WITH ALUMINUM GRATING PER STRUCTURE #147 DETAIL) (SEE CITY STD. DETAIL D-10 FOR CONCRETE BOX DETAILS)
- 300 108.2 -- IMPORTED TRENCH BACKFILL (CLEAN FILL DIRT) (USED AS TRENCH BACKFILL ABOVE THE NEW 18" IRRIGATION PIPE)
- 664 304 -- AGGREGATE BASE COURSE (CLASS 6) (6" THICK) (CONCRETE SIDEWALK)
- 668 304 -- AGGREGATE BASE COURSE (CLASS 6) (15" THICK) (G ROAD)

CONSTRUCTION NOTES, CONT.

- 671 304 -- WASHED ROCK SURFACE COURSE FOR GRAVEL DRIVEWAYS. MATCH EXISTING SURFACE ROCK AS CLOSELY AS POSSIBLE. THICKNESS IS 2" MIN. AND 3" MAX.
- 677 401.06 -- HOT BITUMINOUS PAVEMENT (5" THICK) (PATCHING) (GRADING SX, GYR=75, PG 64-22) (ONE 3" LIFT AND ONE 2" LIFT)
- 689 607 -- CHAIN-LINK FENCE (5' HIGH WITH POSTS INSTALLED ON 10' SPACING) (GALVANIZED CHAIN-LINK MESH AND POSTS) (MATCH AS CLOSELY AS POSSIBLE THE STYLE OF THE EXISTING FENCE)
- 700 608.06 -- MONOLITHIC VERTICAL CURB, GUTTER, AND SIDEWALK (7" WIDE) (MATCH IN KIND)
- 801 PROTECT TREE
- 831 RESET/RELOCATE GAS LINE (XCEL ENERGY) (IF NECESSARY)
- 832 RESET/RELOCATE TELEPHONE LINE (CENTURY LINK) (IF NECESSARY)

REVISION	DESCRIPTION	DATE	DRAWN BY	DATE
REV 1			JCS	2021
REV 2			JCS	2021
REV 3			ALC	2021
REV 4			TCP	2021

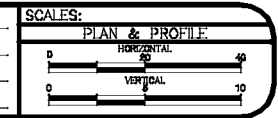

PUBLIC WORKS ENGINEERING DIVISION
PROJECT NO. 207-F2109

2021 G ROAD IRRIGATION MODIFICATION PROJECT
IRRIGATION PLAN - 1

N:\Landproj\24 Road and G Road Intersection\dwg\000 IRRIGATION\IRRIGATION PLAN.dwg, 1/27/2021 3:46:03 PM

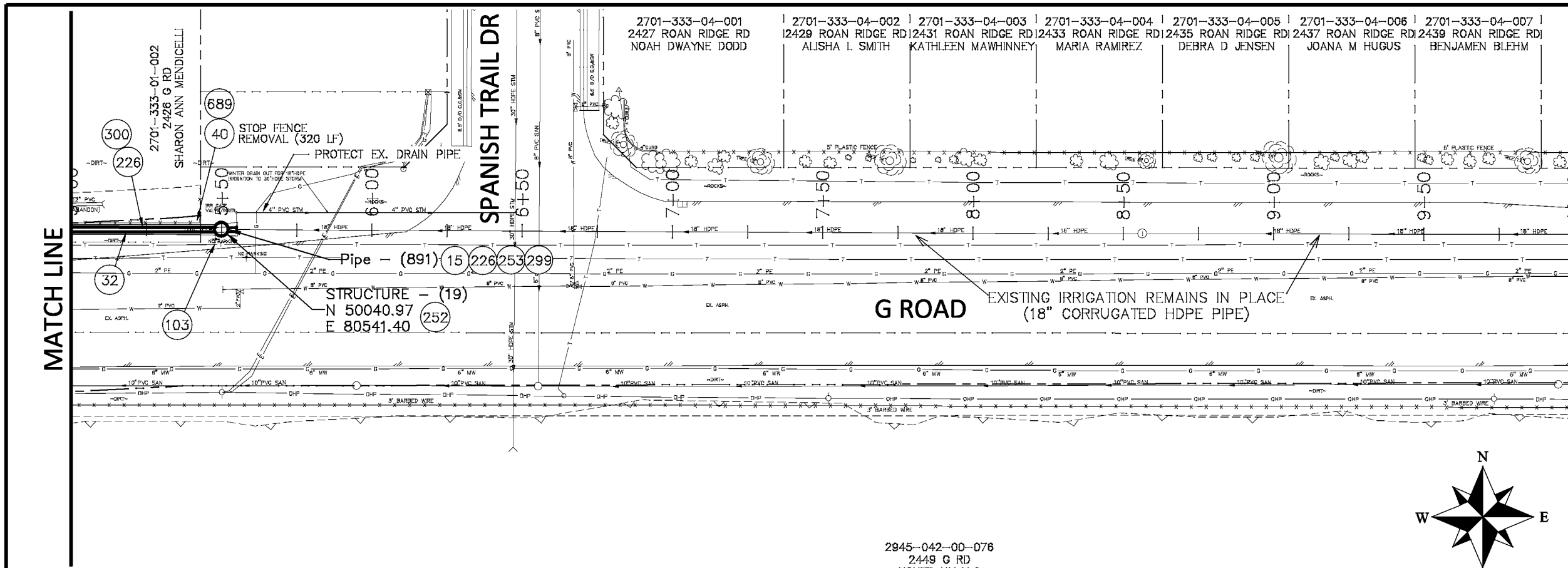

CONSTRUCTION NOTES

- 15 202 -- REMOVAL OF PIPE AS SHOWN (SIZE AND TYPE AS SHOWN ON PLAN)
- 32 202 -- REMOVAL OF CONCRETE DITCH (2" - 3" THICK CONCRETE)
- 40 202 -- REMOVAL OF FENCE (5-FT TALL CHAIN-LINK)
- 103 210 -- RESET SIGN
- 226 102.10/108.2 -- 18" IRRIGATION PIPE (CORRUGATED HDPE ADS N-12 DUAL-WALL WATER TIGHT (WTB) PIPE OR ENGINEER APPROVED EQUAL) (20-FT PIPE LENGTHS) (INCLUDES TYPE A BEDDING AND HAUNCHING MATERIAL AND BACKFILL OF TRENCH WITH NATIVE MATERIALS MEETING 103.16 EARTH BACKFILL MATERIAL.)
- 252 102.12/108.5 -- IRRIGATION BASIC MANHOLE (36" I.D.) (CITY STD. DETAIL D-15) (INCLUDES CONCRETE LID SLAB WITH CAST IN FLUSH INVERTED ALUMINUM RING AND COVER WITH THE WORD "IRRIGATION" CAST INTO THE COVER)
- 253 CONNECT TO EXISTING IRRIGATION PIPE. THE CONTRACT PRICE FOR IRRIGATION PIPE SHALL INCLUDE THE COST OF CONNECTION TO EXISTING PIPELINE.
- 299 106.2 -- CONNECT TO EXISTING IRRIGATION PIPE USING AN 18" DOUBLE WIDE FIELD REPAIR COUPLER BY ADS OR PROJECT ENGINEER APPROVED EQUAL. (USE FOR CONNECTING NEW 18" HDPE PIPE TO EXISTING 18" HDPE PIPE) (INCLUDES POURING A CONCRETE COLLAR AROUND REPAIR COUPLER FOR ADDED PIPE SUPPORT)
- 300 106.2 -- IMPORTED TRENCH BACKFILL (CLEAN FILL DIRT) (USED AS TRENCH BACKFILL ABOVE THE NEW 18" IRRIGATION PIPE)
- 689 607 -- CHAIN-LINK FENCE (5' HIGH WITH POSTS INSTALLED ON 10' SPACING) (GALVANIZED CHAIN-LINK MESH AND POSTS) (MATCH AS CLOSELY AS POSSIBLE THE STYLE OF THE EXISTING FENCE)

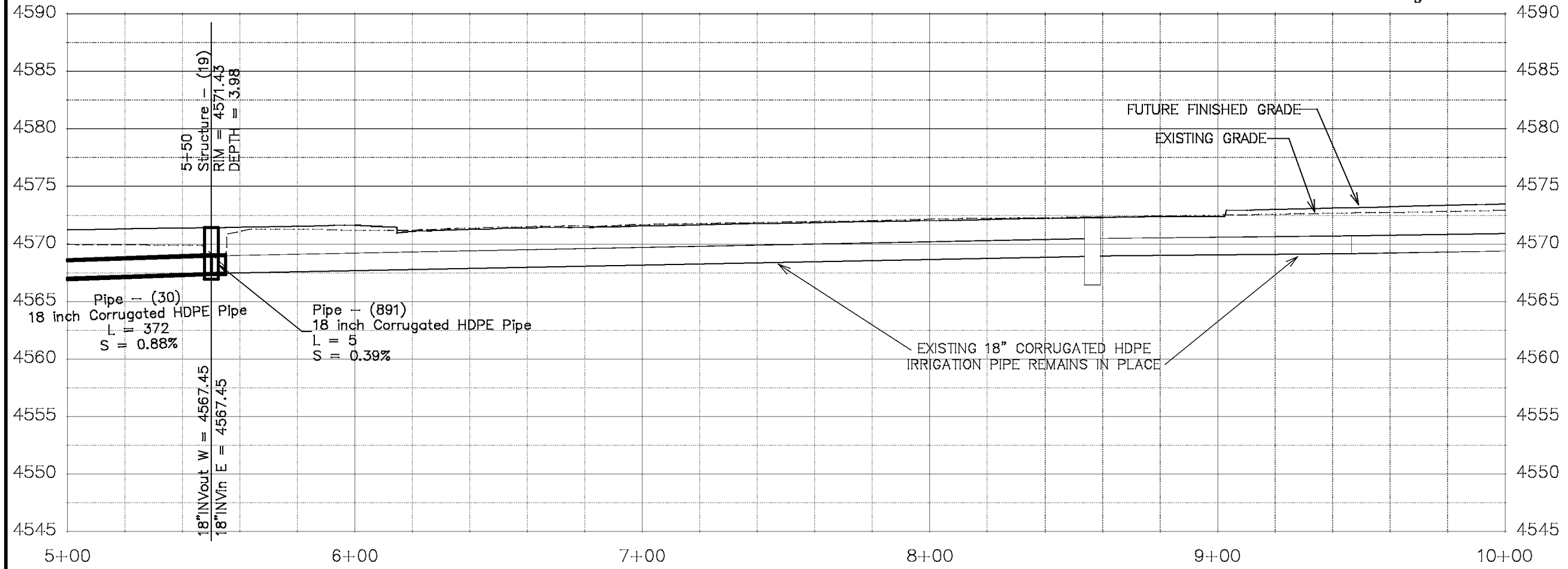
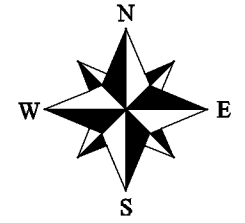

REVISION	DESCRIPTION	DATE	DRAWN BY	DATE
REV 1			JCS	2021
REV 2			JCS	2021
REV 3			ALC	2021
REV 4			TCP	2021

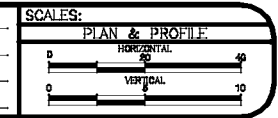

PUBLIC WORKS
ENGINEERING DIVISION
 PROJECT NO. 207-F2109

2021 G ROAD IRRIGATION MODIFICATION PROJECT
IRRIGATION PLAN - 2

N:\Landproj\24 Road and G Road Intersection\dwg\000 IRRIGATION\IRRIGATION PLAN.dwg, 1/27/2021 3:46:19 PM

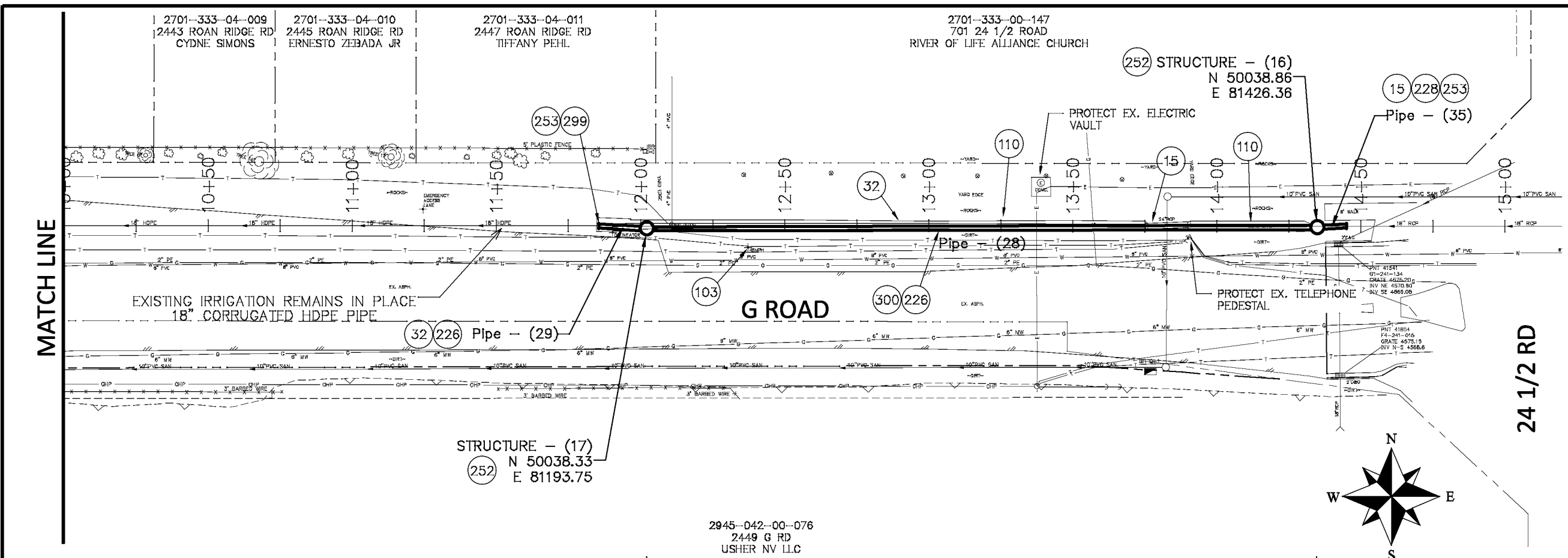

- CONSTRUCTION NOTES**
- (15) 202 -- REMOVAL OF PIPE AS SHOWN. (SIZE AND TYPE AS SHOWN ON PLAN)
 - (32) 202 -- REMOVAL OF CONCRETE DITCH (2" -- 3" THICK CONCRETE)
 - (103) 210 -- RESET SIGN
 - (110) 210 -- RESET LANDSCAPE GROUNDCOVER (COBBLE ROCK) (CONTRACTOR SHALL REMOVE GROUND COVER AND ANY UNDERLYING WEED BARRIER AS NEEDED AND STOCKPILE MATERIALS. CONTRACTOR SHALL RESET THESE MATERIALS AND PROVIDE ADDITIONAL MATERIALS AS NEEDED TO RESTORE LANDSCAPING. ANY AND ALL ADDITIONAL MATERIALS ARE INCIDENTAL.)
 - (226) 102.10/108.2 -- 18" IRRIGATION PIPE (CORRUGATED HDPE ADS N-12 DUAL-WALL, WATER TIGHT (WTR) PIPE OR ENGINEER APPROVED EQUAL) (20'-FT PIPE LENGTHS) (INCLUDES TYPE A BEDDING AND HAUNCHING MATERIAL AND BACKFILL OF TRENCH WITH NATIVE MATERIALS MEETING 103.16 EARTH BACKFILL MATERIAL)
 - (228) 102.10/108.2 -- 18" IRRIGATION PIPE (RCP) (INCLUDES TYPE A BEDDING AND HAUNCHING MATERIALS AND BACKFILL OF TRENCH WITH NATIVE MATERIALS MEETING 103.16 EARTH BACKFILL MATERIAL)
 - (252) 102.12/108.5 -- IRRIGATION BASIC MANHOLE (36" I.D.) (CITY STD. DETAIL, D-15) (INCLUDES CONCRETE LID SLAB WITH CAST IN FLUSH INVERTED ALUMINUM RING AND COVER WITH THE WORD "IRRIGATION" CAST INTO THE COVER)
 - (253) CONNECT TO EXISTING IRRIGATION PIPE. THE CONTRACT PRICE FOR IRRIGATION PIPE SHALL INCLUDE THE COST OF CONNECTION TO EXISTING PIPELINE.
 - (299) 106.2 -- CONNECT TO EXISTING IRRIGATION PIPE USING AN 18" DOUBLE WIDE FIELD REPAIR COUPLER BY ADS OR PROJECT ENGINEER APPROVED EQUAL (USE FOR CONNECTING NEW 18" HDPE PIPE TO EXISTING 18" HDPE PIPE) (INCLUDES POURING A CONCRETE COLLAR AROUND REPAIR COUPLER FOR ADDED PIPE SUPPORT)
 - (300) 106.2 -- IMPORTED TRENCH BACKFILL (CLEAN FILL DIRT) (USED AS TRENCH BACKFILL ABOVE THE NEW 18" IRRIGATION PIPE)

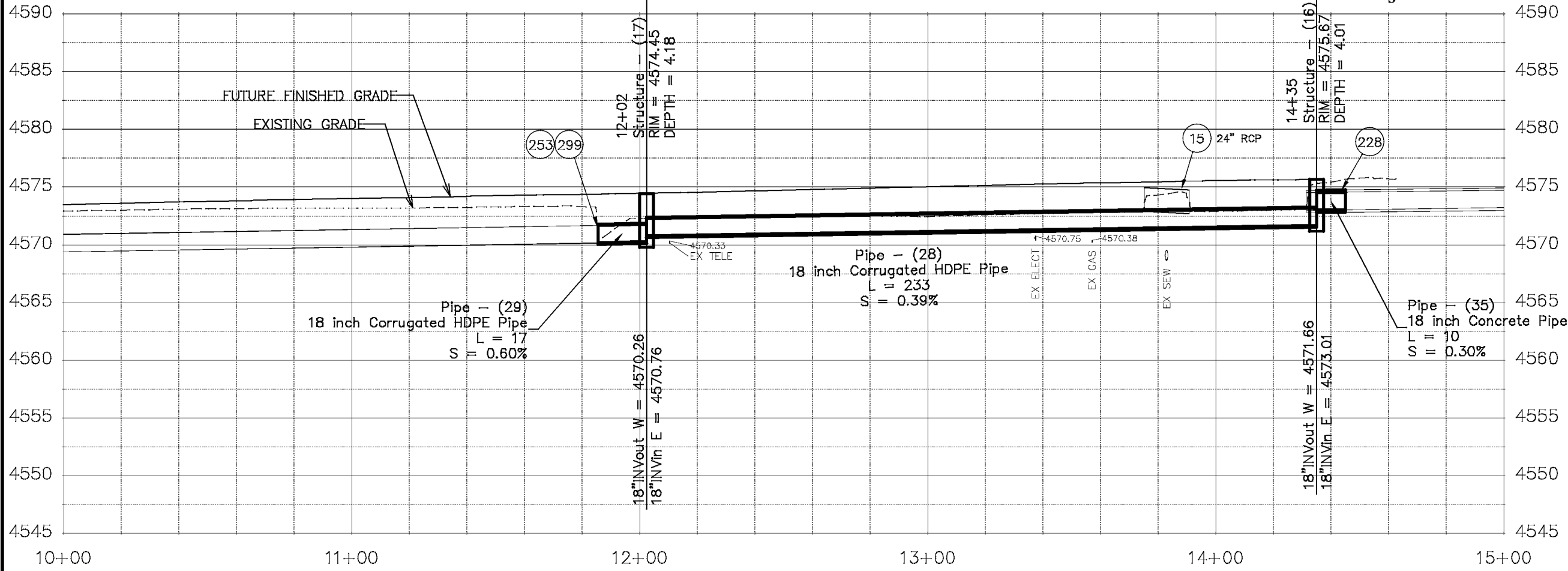

REVISION	DESCRIPTION	DATE	DRAWN BY	DATE
REV 1			JCS	2021
REV 2			JCS	2021
REV 3			ALC	2021
REV 4			TCP	2021

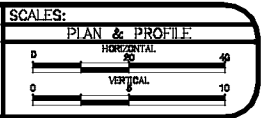

PUBLIC WORKS
 ENGINEERING DIVISION
 PROJECT NO.207-F2109

2021 G ROAD IRRIGATION MODIFICATION
 PROJECT
 IRRIGATION PLAN - 3

N:\Landproj\24 Road and G Road Intersection\dwg\000 IRRIGATION\IRRIGATION PLAN.dwg, 1/27/2021 3:46:38 PM



Purchasing Division

ADDENDUM NO. 1

DATE: February 16, 2021
FROM: City of Grand Junction Purchasing Division
TO: All Offerors
RE: 2021 G Road Irrigation Modification Project
IFB-4870-21-DH

Offerors responding to the above referenced solicitation are hereby instructed that the requirements have been clarified, modified, superseded and supplemented as to this date as hereinafter described.

Please make note of the following clarifications:

1. Q. What are the dates of spring break for Caprock Academy?
 - A. *Caprock Academy is located on 24½ Road north of G Road and their spring break is March 19th through March 26th.*
2. Q. Will the City be able to provide variable message boards?
 - A. *Depending on message board availability, the City can provide at least two, maybe three, variable message boards on G Road and possibly one on 24 Road to inform motorists of the G Road work; as well as, inform the motorists of the temporary G Road closure needed to get irrigation pipe installed across G Road.*
3. The project Bid Schedule has been updated. Pay Item #10, **Irrigation Basic Manhole (36" I.D.)**, has had its bid quantity increased to three (3). The updated Bid Schedule is attached to this Addendum.

The original solicitation for the project noted above is amended as noted.

All other conditions of subject remain the same.

Respectfully,

A handwritten signature in black ink, appearing to read "Duane Hoff Jr.", written over a horizontal line.

Duane Hoff Jr., Senior Buyer
City of Grand Junction, Colorado

Bid Schedule: 2021 G Road Irrigation Modification Project

ADDENDUM #1

Item No.	CDOT, City Ref.	Description	Quantity	Units	Unit Price	Total Price
1	108.2	8" Plastic Starter Coupler (Gasket x Spigot) (8" O.D.) (For use in the Rectangular Box Structure #147)	1.	Each	\$ _____	\$ _____
2	108.2	10" Irrigation Pipe (AWWA C-900, DR-18) (Structure #23 Water Drain Pipe to Leach Creek)	25.	Lin. Ft.	\$ _____	\$ _____
3	108.2	10" Irrigation Pipe (CMP) (Galvanized CMP at Structure #23) (Includes cost of connection into existing CMP pipe that crosses Leach Creek)	10.	Lin. Ft.	\$ _____	\$ _____
4	108.2	12" Irrigation Pipe (AWWA C-900, DR-18) (Includes Type A Bedding and Haunching Material and Backfill of Trench with Native Materials meeting 103.16 Earth Backfill Material)	80.	Lin. Ft.	\$ _____	\$ _____
5	108.2	18" Irrigation Pipe (RCP) (Includes Cost of Connection to Existing RCP pipe and Type A Bedding and Haunching Material and Backfill of Trench with Native Materials meeting 103.16 Earth Backfill Material)	10.	Lin. Ft.	\$ _____	\$ _____
6	108.2	18" Irrigation Pipe (HDPE) (Corrugated HDPE ADS N-12 Dual-Wall, Water Tight (WTIB) Pipe or Engineer Approved Equal) (20-ft Pipe Lengths) (Includes Type A Bedding and Haunching Material and Backfill of Trench with Native Materials meeting 103.16 Earth Backfill Material)	710.	Lin. Ft.	\$ _____	\$ _____
7	108.2	18" Double Wide Field Repair Coupler by ADS or Project Engineer Approved Equal (Use for Connecting new 18" HDPE pipe to Existing 18" HDPE Pipe) (Includes Pouring a Concrete Collar around Repair Coupler for added support)	2.	Each	\$ _____	\$ _____
8	108.2	Imported Trench Backfill (Class 3) (Includes haul and disposal of unsuitable excavated material) (Assumed material unit weight = 133 lbs/ft ³)	40.	Ton	\$ _____	\$ _____

Bid Schedule: 2021 G Road Irrigation Modification Project

ADDENDUM #1

Item No.	CDOT, City Ref.	Description	Quantity	Units	Unit Price	Total Price
9	108.2	Imported Trench Backfill (Clean Fill Dirt) (Clean Fill Dirt shall be used where there isn't enough native material available to backfill new irrigation pipe trench) (Anticipated for use between Pipe Stations 1+78 to 14+35)	250.	Cu. Yd.	\$ _____	\$ _____
10	108.5	Irrigation Basic Manhole (36" I.D.) (Includes Concrete Lid Slab with Cast-in-Flush Inverted Aluminum Ring and Cover with the word "Irrigation" Cast into the Cover)	3.	Each	\$ _____	\$ _____
11	108.5	Irrigation Basic Manhole (48" I.D.) (Includes Concrete Lid Slab with Cast-in-Flush Inverted Aluminum Ring and Cover with the word "Irrigation" Cast into the Cover)	1.	Each	\$ _____	\$ _____
12	108.5	Irrigation Structure Manhole (48" I.D.) (See Structure #23 Details) (Includes Fresno Series 5500 Galvanized Toggle Gates (3 Total) or Engineer Approved Equal, and Aluminum Bar Grating and Locking Bar Assembly as shown in detail)	1.	Each	\$ _____	\$ _____
13	108.5	Manhole Barrel Section (48" I.D.) (D>5')	4.	Vert. Ft.	\$ _____	\$ _____
14	108.5	Rectangular Irrigation Structure (24" x 36") (Large Area Inlet Box with Aluminum Bar Grating per Structure #147 Detail) (See City Std. Detail D-10 for Concrete Box Details)	1.	Each	\$ _____	\$ _____
15	202	Removal of Concrete Ditch (Existing Concrete is about 2-3 Inches Thick)	630.	Lin. Ft.	\$ _____	\$ _____
16	202	Removal of Asphalt Mat (Full-Depth)	71.	Sq. Yd.	\$ _____	\$ _____
17	202	Removal of Existing Pipe (Size as Shown on the Plans)	260.	Lin. Ft.	\$ _____	\$ _____
18	202	Remove Existing Irrigation Structures (Concrete)	2.	Each	\$ _____	\$ _____
19	202	Removal of Tree	1.	Each	\$ _____	\$ _____
20	202	Removal of Concrete (Includes, but not limited to, curb, gutter, sidewalk, driveway, slabs, V-pans, curb ramps, intersection corners, aprons, landscape borders, and concrete walls)	11.	Sq. Yd.	\$ _____	\$ _____
21	202	Removal of Fence (5-ft Tall Chain-Link)	320.	Lin. Ft.	\$ _____	\$ _____

Bid Schedule: 2021 G Road Irrigation Modification Project

ADDENDUM #1

Item No.	CDOT, City Ref.	Description	Quantity	Units	Unit Price	Total Price
22	210	Adjust Existing Water Service Pipe (Property 2426 G Road) (Cost of Adjusting Existing Water Service pipe shall be included in the Cost of the Irrigation Pipe and shall include all necessary fittings and pipe required to adjust/relocate water service) (The water service is assumed to be 3/4" dia. Copper service pipe)	1.	Lump Sum	\$ _____	\$ _____
23	210	Reset Sign	3.	Each	\$ _____	\$ _____
24	210	Reset Gate (Chain-Link Gate) (Attached existing gate to the proposed new chain-link fence)	2.	Each	\$ _____	\$ _____
25	210	Reset Landscape Groundcover (Cobble Rock) (Match in Kind)	1.	Lump Sum	\$ _____	\$ _____
26	304	Aggregate Base Course (Class 6) (8" thick) (Concrete Sidewalk)	11.	Sq. Yd.	\$ _____	\$ _____
27	304	Aggregate Base Course (Class 6) (15" thick) (G Road)	71.	Sq. Yd.	\$ _____	\$ _____
28	304	Washed Rock Surface Course for Gravel Driveways (Match Existing Surface Rock as closely as possible) (2" - 3" Thick)	85.	Sq. Yd.	\$ _____	\$ _____
29	401	Cold Mix Asphalt (Temporary Patching) (2" Thick) (To be used on G Road between Stationing 1+21 to 1+62)	80.	Sq. Yd.	\$ _____	\$ _____
30	401	Hot Bituminous Pavement (Patching) (5" Thick) (Grading SX, PG 64-22) (GYR.=75) (One 3" Lift and One 2" Lift)	80.	Sq. Yd.	\$ _____	\$ _____
31	407	Emulsified Asphalt (Tack Coat)	7.	Gallon	\$ _____	\$ _____
32	607	Chain-Link Fence (5' High) (Galvanized) (10' Wide Post Spacing, Typ.)	320.	Lin. Ft.	\$ _____	\$ _____
33	608	Monolithic Vertical Curb, Gutter, and Sidewalk (7-ft wide)	11.	Sq. Yd.	\$ _____	\$ _____
34	620	Portable Sanitary Facility	1.	Each	\$ _____	\$ _____
35	625	Construction Surveying (Includes As-Built Drawings)	1.	Lump Sum	\$ _____	\$ _____
36	626	Mobilization	1.	Lump Sum	\$ _____	\$ _____
37	630	Traffic Control Plan	1.	Lump Sum	\$ _____	\$ _____

Bid Schedule: 2021 G Road Irrigation Modification Project ADDENDUM #1

Item No.	CDOT, City Ref.	Description	Quantity	Units	Unit Price	Total Price
38	630	Traffic Control (Complete in Place)	1.	Lump Sum	\$ _____	\$ _____
39	630	Flagging	500.	Hour	\$ _____	\$ _____
MCR		Minor Contract Revisions	---	---	---	<u>\$ 12,000.00</u>
Bid Amount:						\$ _____

Bid Amount:

dollars

Contractor Name:

Contractor Address:

Contractor Phone #:

4. Contractor's Bid Form

Bid Date: 2/19/2021

Project: IFB-4870-21-DH "2021 G Road Irrigation Modification Project"

Bidding Company: DIRTWORKS CONST., LLC

Name of Authorized Agent: Hayley G. Hughes

Email: dirtworksconstruction@gmail.com

Telephone: 970-256-11091 Address: 84th 20 1/2 RD

City: FRUITA State: CO Zip: 81521

The undersigned Bidder, in compliance with the Invitation for Bids, having examined the Instruction to Bidders, General Contract Conditions, Statement of Work, Specifications, and any and all Addenda thereto, having investigated the location of, and conditions affecting the proposed work, hereby proposes to furnish all labor, materials and supplies, and to perform all work for the Project in accordance with Contract Documents, within the time set forth and at the prices stated below. These prices are to cover all expenses incurred in performing the work required under the Contract Documents, of which this Contractor's Bid Form is a part.

The undersigned Contractor does hereby declare and stipulate that this offer is made in good faith without collusion or connection to any person(s) providing an offer for the same work, and that it is made in pursuance of, and subject to, all terms and conditions of the Instructions to Bidders, the Specifications, and all other Solicitation Documents, all of which have been examined by the undersigned.

The Contractor also agrees that if awarded the Contract, to provide insurance certificates within ten (10) working days of the date of Notification of Award. Submittal of this offer will be taken by the Owner as a binding covenant that the Contractor will be prepared to complete the project in its entirety.

The Owner reserves the right to make the award on the basis of the offer deemed most favorable, to waive any formalities or technicalities and to reject any or all offers. It is further agreed that this offer may not be withdrawn for a period of sixty (60) calendar days after closing time. Submission of clarifications and revised offers automatically establish a new thirty day (30) period.

Prices in the bid proposal have not knowingly been disclosed with another provider and will not be prior to award.

- Prices in this bid proposal have been arrived at independently, without consultation, communication or agreement for the purpose of restricting competition.
- No attempt has been made nor will be to induce any other person or firm to submit a bid proposal for the purpose of restricting competition.
- The individual signing this bid proposal certifies they are a legal agent of the offeror, authorized to represent the offeror and is legally responsible for the offer with regard to supporting documentation and prices provided.
- Direct purchases by the City of Grand Junction are tax exempt from Colorado Sales or Use Tax. Tax exempt No. 98-903544. The undersigned certifies that no Federal, State, County or Municipal tax will be added to the above quoted prices.
- City of Grand Junction payment terms shall be Net 30 days.
- Prompt payment discount of 0 percent of the net dollar will be offered to the Owner if the invoice is paid within N/A days after the receipt of the invoice. The Owner reserves the right to take into account any such discounts when determining the bid award.

RECEIPT OF ADDENDA: the undersigned Contractor acknowledges receipt of Addenda to the Solicitation, Specifications, and other Contract Documents.

State number of Addenda received: 1

It is the responsibility of the Bidder to ensure all Addenda have been received and acknowledged.

By signing below, the Undersigned agree to comply with all terms and conditions contained herein.

Company: DIRTWORKS Construction, LLC

Authorized Signature: Hayley G. Hughes

Title: OFFICER

Bid Schedule: 2021 G Road Irrigation Modification Project

ADDENDUM #1

Item No.	CDOT, City Ref.	Description	Quantity	Units	Unit Price	Total Price
1	108.2	8" Plastic Starter Coupler (Gasket x Spigot) (8" O.D.) (For use in the Rectangular Box Structure #147)	1.	Each	\$ <u>175.00</u>	\$ <u>175.00</u>
2	108.2	10" Irrigation Pipe (AWWA C-900, DR-18) (Structure #23 Water Drain Pipe to Leach Creek)	25.	Lin. Ft.	\$ <u>29.00</u>	\$ <u>725.00</u>
3	108.2	10" Irrigation Pipe (CMP) (Galvanized CMP at Structure #23) (Includes cost of connection into existing CMP pipe that crosses Leach Creek)	10.	Lin. Ft.	\$ <u>56.00</u>	\$ <u>560.00</u>
4	108.2	12" Irrigation Pipe (AWWA C-900, DR-18) (Includes Type A Bedding and Haunching Material and Backfill of Trench with Native Materials meeting 103.16 Earth Backfill Material)	80.	Lin. Ft.	\$ <u>31.25</u>	\$ <u>2,500.00</u>
5	108.2	18" Irrigation Pipe (RCP) (Includes Cost of Connection to Existing RCP pipe and Type A Bedding and Haunching Material and Backfill of Trench with Native Materials meeting 103.16 Earth Backfill Material)	10.	Lin. Ft.	\$ <u>58.00</u>	\$ <u>580.00</u>
6	108.2	18" Irrigation Pipe (HDPE) (Corrugated HDPE ADS N-12 Dual-Wall, Water Tight (WTIB) Pipe or Engineer Approved Equal) (20-ft Pipe Lengths) (Includes Type A Bedding and Haunching Material and Backfill of Trench with Native Materials meeting 103.16 Earth Backfill Material)	710.	Lin. Ft.	\$ <u>35.00</u>	\$ <u>24,850.00</u>
7	108.2	18" Double Wide Field Repair Coupler by ADS or Project Engineer Approved Equal (Use for Connecting new 18" HDPE pipe to Existing 18" HDPE Pipe) (Includes Pouring a Concrete Collar around Repair Coupler for added support)	2.	Each	\$ <u>525.00</u>	\$ <u>1,050.00</u>
8	108.2	Imported Trench Backfill (Class 3) (Includes haul and disposal of unsuitable excavated material) (Assumed material unit weight = 133 lbs/ft ³)	40.	Ton	\$ <u>32.00</u>	\$ <u>1,280.00</u>

Bid Schedule: 2021 G Road Irrigation Modification Project

ADDENDUM #1

Item No.	CDOT, City Ref.	Description	Quantity	Units	Unit Price	Total Price
9	108.2	Imported Trench Backfill (Clean Fill Dirt) (Clean Fill Dirt shall be used where there isn't enough native material available to backfill new irrigation pipe trench) (Anticipated for use between Pipe Stations 1+78 to 14+35)	250.	Cu. Yd.	\$ <u>1.25</u>	\$ <u>312.00</u>
10	108.5	Irrigation Basic Manhole (36" I.D.) (Includes Concrete Lid Slab with Cast-in-Flush Inverted Aluminum Ring and Cover with the word "Irrigation" Cast into the Cover)	3.	Each	\$ <u>3,200.00</u>	\$ <u>9,600.00</u>
11	108.5	Irrigation Basic Manhole (48" I.D.) (Includes Concrete Lid Slab with Cast-in-Flush Inverted Aluminum Ring and Cover with the word "Irrigation" Cast into the Cover)	1.	Each	\$ <u>3,800.00</u>	\$ <u>3,800.00</u>
12	108.5	Irrigation Structure Manhole (48" I.D.) (See Structure #23 Details) (Includes Fresno Series 5500 Galvanized Toggle Gates (3 Total) or Engineer Approved Equal, and Aluminum Bar Grating and Locking Bar Assembly as shown in detail)	1.	Each	\$ <u>5,800.00</u>	\$ <u>5,800.00</u>
13	108.5	Manhole Barrel Section (48" I.D.) (D>5')	4.	Vert. Ft.	\$ <u>150.00</u>	\$ <u>600.00</u>
14	108.5	Rectangular Irrigation Structure (24" x 36") (Large Area Inlet Box with Aluminum Bar Grating per Structure #147 Detail) (See City Std. Detail D-10 for Concrete Box Details)	1.	Each	\$ <u>6,200.00</u>	\$ <u>6,200.00</u>
15	202	Removal of Concrete Ditch (Existing Concrete is about 2-3 Inches Thick)	630.	Lin. Ft.	\$ <u>1.50</u>	\$ <u>945.00</u>
16	202	Removal of Asphalt Mat (Full-Depth)	71.	Sq. Yd.	\$ <u>30.00</u>	\$ <u>2,130.00</u>
17	202	Removal of Existing Pipe (Size as Shown on the Plans)	260.	Lin. Ft.	\$ <u>5.25</u>	\$ <u>1,365.00</u>
18	202	Remove Existing Irrigation Structures (Concrete)	2.	Each	\$ <u>400.00</u>	\$ <u>800.00</u>
19	202	Removal of Tree	1.	Each	\$ <u>500.00</u>	\$ <u>500.00</u>
20	202	Removal of Concrete (Includes, but not limited to, curb, gutter, sidewalk, driveway, slabs, V-pans, curb ramps, intersection corners, aprons, landscape borders, and concrete walls)	11.	Sq. Yd.	\$ <u>50.00</u>	\$ <u>550.00</u>
21	202	Removal of Fence (5-ft Tall Chain-Link)	320.	Lin. Ft.	\$ <u>4.00</u>	\$ <u>1,280.00</u>

Bid Schedule: 2021 G Road Irrigation Modification Project

ADDENDUM #1

Item No.	CDOT, City Ref.	Description	Quantity	Units	Unit Price	Total Price
22	210	Adjust Existing Water Service Pipe (Property 2426 G Road) (Cost of Adjusting Existing Water Service pipe shall be included in the Cost of the Irrigation Pipe and shall include all necessary fittings and pipe required to adjust/relocate water service) (The water service is assumed to be 3/4" dia. Copper service pipe)	1.	Lump Sum	\$ <u>700.00</u>	\$ <u>700.00</u>
23	210	Reset Sign	3.	Each	\$ <u>150.00</u>	\$ <u>450.00</u>
24	210	Reset Gate (Chain-Link Gate) (Attached existing gate to the proposed new chain-link fence)	2.	Each	\$ <u>500.00</u>	\$ <u>1,000.00</u>
25	210	Reset Landscape Groundcover (Cobble Rock) (Match in Kind)	1.	Lump Sum	\$ <u>1,500.00</u>	\$ <u>1,500.00</u>
26	304	Aggregate Base Course (Class 6) (8" thick) (Concrete Sidewalk)	11.	Sq. Yd.	\$ <u>48.00</u>	\$ <u>528.00</u>
27	304	Aggregate Base Course (Class 6) (15" thick) (G Road)	71.	Sq. Yd.	\$ <u>15.95</u>	\$ <u>1,132.45</u>
28	304	Washed Rock Surface Course for Gravel Driveways (Match Existing Surface Rock as closely as possible) (2" - 3" Thick)	85.	Sq. Yd.	\$ <u>4.25</u>	\$ <u>361.25</u>
29	401	Cold Mix Asphalt (Temporary Patching) (2" Thick) (To be used on G Road between Stationing 1+21 to 1+62)	80.	Sq. Yd.	\$ <u>30.00</u>	\$ <u>2,400.00</u>
30	401	Hot Bituminous Pavement (Patching) (5" Thick) (Grading SX, PG 64-22) (GYR.=75) (One 3" Lift and One 2" Lift)	80.	Sq. Yd.	\$ <u>76.00</u>	\$ <u>6,080.00</u>
31	407	Emulsified Asphalt (Tack Coat)	7.	Gallon	\$ <u>15.00</u>	\$ <u>105.00</u>
32	607	Chain-Link Fence (5' High) (Galvanized) (10' Wide Post Spacing, Typ.)	320.	Lin. Ft.	\$ <u>15.25</u>	\$ <u>4,880.00</u>
33	608	Monolithic Vertical Curb, Gutter, and Sidewalk (7-ft wide)	11.	Sq. Yd.	\$ <u>137.00</u>	\$ <u>1,507.00</u>
34	620	Portable Sanitary Facility	1.	Each	\$ <u>200.00</u>	\$ <u>200.00</u>
35	625	Construction Surveying (Includes As-Built Drawings)	1.	Lump Sum	\$ <u>2,950.00</u>	\$ <u>2,950.00</u>
36	626	Mobilization	1.	Lump Sum	\$ <u>1,000.00</u>	\$ <u>1,000.00</u>
37	630	Traffic Control Plan	1.	Lump Sum	\$ <u>300.00</u>	\$ <u>300.00</u>

Bid Schedule: 2021 G Road Irrigation Modification Project ADDENDUM #1

Item No.	CDOT, City Ref.	Description	Quantity	Units	Unit Price	Total Price
38	630	Traffic Control (Complete in Place)	1.	Lump Sum	\$ <u>4,800.00</u>	\$ <u>4,800.00</u>
39	630	Flagging	500.	Hour	\$ <u>28.00</u>	\$ <u>14,000.00</u>
MCR		Minor Contract Revisions	---	---	---	\$ <u>12,000.00</u>
Bid Amount:						\$ <u>124,495.70</u>

Bid Amount:

ONE HUNDRED TWENTY FOUR THOUSAND, FOUR NINETY FIVE & 70/100 dollars

Contractor Name: DIRTWORKS CONSTRUCTION, LLC
Contractor Address: 846 20 1/2 RD, FRUITA, CO 81521
Contractor Phone #: (970) 256-1691

AIA[®] Document A310[™] – 2010

Bid Bond

Bond Number: BND1006448-00

CONTRACTOR:

(Name, legal status and address)

Dirtworks Construction, LLC
846 20 1/2 Road
Fruita, CO 81521

SURETY:

(Name, legal status and principal place of business)

Fair American Insurance and Reinsurance Company
365 Northridge Road, Suite 400
Atlanta, GA 30350

This document has important legal consequences. Consultation with an attorney is encouraged with respect to its completion or modification.

Any singular reference to Contractor, Surety, Owner or other party shall be considered plural where applicable.

OWNER:

(Name, legal status and address)

City of Grand Junction
250 N. 5th Street
Grand Junction, CO

BOND AMOUNT: Five Percent of Amount Bid Not To Exceed Twenty Thousand and 00/100 Dollars (\$20,000.00)

PROJECT:

(Name, location or address, and Project number, if any)

IFB-4870-21-DH / 2021 G Road Irrigation Modification Project

Project Number, if any:

IFB-4870-21-DH

The Contractor and Surety are bound to the Owner in the amount set forth above, for the payment of which the Contractor and Surety bind themselves, their heirs, executors, administrators, successors and assigns, jointly and severally, as provided herein. The conditions of this Bond are such that if the Owner accepts the bid of the Contractor within the time specified in the bid documents, or within such time period as may be agreed to by the Owner and Contractor, and the Contractor either (1) enters into a contract with the Owner in accordance with the terms of such bid, and gives such bond or bonds as may be specified in the bidding or Contract Documents, with a surety admitted in the jurisdiction of the Project and otherwise acceptable to the Owner, for the faithful performance of such Contract and for the prompt payment of labor and material furnished in the prosecution thereof; or (2) pays to the Owner the difference, not to exceed the amount of this Bond, between the amount specified in said bid and such larger amount for which the Owner may in good faith contract with another party to perform the work covered by said bid, then this obligation shall be null and void, otherwise to remain in full force and effect. The Surety hereby waives any notice of an agreement between the Owner and Contractor to extend the time in which the Owner may accept the bid. Waiver of notice by the Surety shall not apply to any extension exceeding sixty (60) days in the aggregate beyond the time for acceptance of bids specified in the bid documents, and the Owner and Contractor shall obtain the Surety's consent for an extension beyond sixty (60) days.

If this Bond is issued in connection with a subcontractor's bid to a Contractor, the term Contractor in this Bond shall be deemed to be Subcontractor and the term Owner shall be deemed to be Contractor.

When this Bond has been furnished to comply with a statutory or other legal requirement in the location of the Project, any provision in this Bond conflicting with said statutory or legal requirement shall be deemed deleted herefrom and provisions conforming to such statutory or other legal requirement shall be deemed incorporated herein. When so furnished, the intent is that this Bond shall be construed as a statutory bond and not as a common law bond.

Signed and sealed this 19th day of February, 2021

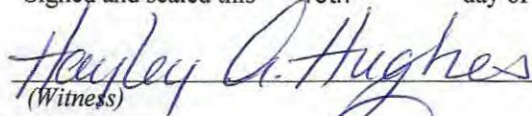

(Witness)

Dirtworks Construction, LLC
(Principal) _____ *(Seal)*

(Title) OWNER / PRESIDENT

Fair American Insurance and Reinsurance Company
(Surety) _____ *(Seal)*

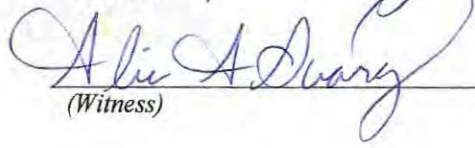
Stefan E. Tauger, Attorney In Fact
(Title)

(Witness)

FAIR AMERICAN INSURANCE AND REINSURANCE COMPANY
One Liberty Plaza, 165 Broadway, New York, NY 10006
POWER OF ATTORNEY

Know all men by these Presents, that Fair American Insurance and Reinsurance Company ("Company"), a New York corporation, had made, constituted and appointed, and by these presents does make, constitute and appoint, Andrew C. Heaner of Atlanta, Georgia; Stefan E. Tauger of Parker, Colorado; Arthur S. Johnson of Atlanta, Georgia; James E. Feldner of West Lake, Ohio; Jeffery L. Booth of Blacklick, Ohio; Melanie J. Stokes of Atlanta, Georgia; David R. Brett of Columbia, South Carolina; Scott E. Stoltzner of Birmingham, Alabama; Jason S. Centrella of Jacksonville, Florida; Matthew W. Hollingsworth of Addison, TX; Michael J. Brown of Cumming, Georgia; Tamara D. Johnson of Atlanta, Georgia; Omar G. Guerra of Overland Park, Kansas; or Douglas Berrett Miller of Jacksonville, Florida EACH as its true and lawful attorney-in-fact to sign, execute, seal, deliver for, and on behalf of the said Company, and as its act and deed any place in the United States any and all surety, bonds, undertakings, recognizances and contracts of suretyship to be given to all obligees provided that no bond or undertaking or contract of suretyship executed under this authority shall exceed in amount of the sum of \$5,000,000 (Five Million Dollars), any single instance. Provided, however, that this power of attorney limits the acts of those named herein; and they shall have no authority to bind the Company except in the manner stated and to the extent of any limitation herein.

This Power of Attorney is granted and is signed and sealed by facsimile under and by the authority of the following Resolutions adopted pursuant to due authorization by the Board of Directors of the Company on the 2nd day of February, 2016.

RESOLVED, that the President, Chairman, or any Senior Vice President or Vice President of the Company, in conjunction with any Senior Vice President or Vice President, be, and that each or any of them hereby is, authorized to appoint Attorneys-in-fact of the Company as may be necessary to act on behalf of the Company to make, execute, seal, acknowledge and deliver as surety any and all bonds, undertakings, recognizances, contracts of suretyship and other surety obligations. Such Attorneys-in-fact, subject to the limitations set forth in their respective powers of attorney, shall have full power to bind the Company by their signature and execution of any such instruments and to attach thereto the seal of the Company. When so executed such instruments shall be as binding as if signed by the President and attested by the Secretary.

FURTHER RESOLVED, that any and all Powers of Attorney and Certified Copies of such Powers of Attorney and certification in respect thereto, granted and executed by the President or Senior Vice President, in conjunction with any Senior Vice President or Vice President of the Company, shall be binding on the Company to the same extent as if all signatures therein were manually affixed, even though one or more of any such signatures thereon may be facsimile.

IN WITNESS WHEREOF, the Company has caused its official seal to be hereto affixed, and these presents to be sealed with its corporate seal and duly attested to by these Senior Vice Presidents this 7th day of January 2020.



Fair American Insurance and Reinsurance Company

By: [Signature]
Christopher O'Gwen, Senior Vice President

By: [Signature]
Suzanne A. Spantidos, Senior Vice President

STATE of NEW YORK
COUNTY of NEW YORK

On January 07, 2020 before me, the above named Senior Vice Presidents, personally appeared, who proved to me on the basis of satisfactory evidence to be the persons whose names are subscribed to the within instrument and acknowledged to me that they executed the same in their authorized capacities, that they know the seal of Fair American Insurance and Reinsurance Company, and that their signatures and the seals of Fair American Insurance and Reinsurance Company were duly affixed and subscribed to said instrument by the authority and direction of the Company. I certify under PENALTY OF PERJURY under the laws of the State of New York that the foregoing paragraph is true and correct.

WITNESS my hand and official seal.

Signature [Signature] (Seal)

I, Christopher O'Gwen, the undersigned, an Officer of Fair American Insurance and Reinsurance Company, a New York Corporation, DO HEREBY CERTIFY that the foregoing and attached Power of Attorney is a true and correct copy of the original power of attorney, and do hereby further certify that the said Powers are still in force and effect.

Signed and sealed at the City of New York. Dated the 19th day of February, 2021



[Signature]
Christopher O'Gwen, Senior Vice President

No. 2448 [Stamp] December 7, 2023

For Bid Bond # BND1006448-00

