

ENGINEERING DIVISION



**PUBLIC WORKS
& PLANNING**

STANDARD CONTRACT DOCUMENTS FOR CAPITAL IMPROVEMENTS CONSTRUCTION

REVISED JULY, 2010



Standard Contract Documents for Capital Improvements Construction

TABLE OF CONTENTS

SECTION	PAGE PREFIX	SECTION COLOR
STANDARD FORMS		
Notice of Award.....		WHITE
Contract	C	WHITE
Performance Bond		WHITE
Payment Bond		WHITE
Notice To Proceed		WHITE
Field Order		WHITE
Work Change Request		WHITE
Request for Adjustment		WHITE
Work Change Authorization		WHITE
Change Order		WHITE
Certificate For Payment		WHITE
Notice of Substantial Completion		WHITE
Notice of Partial Acceptance		WHITE
Notice of Final Acceptance		WHITE
Notice of Final Payment.....		WHITE
Final Receipt and Release		WHITE
CONTRACT CONDITIONS		
General Contract Conditions.....	G	CANARY
STANDARD SPECIFICATIONS		
Standard Specifications for Road and Bridge Construction	R&B	GREEN
Standard Specifications for Construction of Underground Utilities - Water Lines, Sanitary Sewers, Storm Drains, Underdrains and Irrigation Systems	UU	BLUE
STANDARD DETAILS FOR CONSTRUCTION OF STREETS, TRAILS, STORM DRAINS AND UTILITIES.....		
		WHITE



PUBLIC WORKS
& PLANNING

NOTICE OF AWARD

Date: ?
Contractor: ?
From: City of Grand Junction
Department of Public Works and Planning

? Project Engineer
Project: ?

The City of Grand Junction has considered the Bid submitted by the Contractor for the Project, in response to the Invitation to Bid.

The Contractor is hereby notified that the Bid received from the Contractor for the Project in the amount of \$? was accepted by the City Council on ?. The Contractor is hereby awarded all or portions of the Project described as: the entire project as itemized in the Bid Schedule in the Bid Form.

The Contractor is required to execute and submit four (4) copies of the Contract and submit two (2) copies each of the Performance Bond, Payment Bond and Certificates of Insurance within ten (10) calendar days of the date of this Notice of Award. If the Contractor fails to execute the Contract and furnish the Bonds and Certificates within ten (10) calendar days, the City shall be entitled to forfeiture of the Bid Guaranty to the City. The City shall also be entitled to such other rights as may be granted by law or the Contract Documents.

CONTRACTOR ACKNOWLEDGMENT

Receipt of this Notice to Award is hereby acknowledged:

Contractor: ?
By: _____
Title: _____
Date: _____

The Contractor is required to return an acknowledged copy of the Notice of Award to the City.

CITY OF GRAND JUNCTION, COLORADO
DEPARTMENT OF PUBLIC WORKS AND PLANNING
ENGINEERING DIVISION

CONTRACT

This CONTRACT made and entered into this ____ day of _____, _____, by and between the **City of Grand Junction, Colorado**, a Municipal Corporation in the County of Mesa, State of Colorado, hereinafter in the Contract Documents referred to as the "City" and ?????????? hereinafter in the Contract Documents referred to as the "Contractor."

WITNESSETH:

WHEREAS, the City advertised that sealed Bids would be received for furnishing all labor, tools, supplies, equipment, materials, and everything necessary and required for the Project described by the Contract Documents and known as ??????????????????????.

WHEREAS, the Contract has been awarded to the above named Contractor by the City, and said Contractor is now ready, willing and able to perform the Work specified in the Notice of Award, in accordance with the Contract Documents;

NOW, THEREFORE, in consideration of the compensation to be paid the Contractor, the mutual covenants hereinafter set forth and subject to the terms hereinafter stated, it is mutually covenanted and agreed as follows:

ARTICLE 1

Contract Documents: It is agreed by the parties hereto that the following list of instruments, drawings, and documents which are attached hereto, bound herewith, or incorporated herein by reference constitute and shall be referred to either as the "Contract Documents" or the "Contract", and all of said instruments, drawings, and documents taken together as a whole constitute the Contract between the parties hereto, and they are fully a part of this agreement as if they were set out verbatim and in full herein:

- Standard Contract Documents For Capital Improvements Construction (latest edition), completed and signed, as appropriate, by the required parties;
- Bid Documents for the Project; ??????????????????????
- Work Change Requests (directing that changed work be performed);
- Field Orders;
- Change Orders.

ARTICLE 2

Definitions: The definitions provided in the General Contract Conditions apply to the terms used in the Contract and all the Contract Documents.

ARTICLE 3

Contract Work: The Contractor agrees to furnish all labor, tools, supplies, equipment, materials, and all that is necessary and required to complete the tasks associated with the Work described, set forth, shown, and included in the Contract Documents as indicated in the Notice of Award.

ARTICLE 4

Contract Time and Liquidated Damages: Time is of the essence with respect to this Contract. The Contractor hereby agrees to commence Work under the Contract on or before the date specified in a written Notice to Proceed from the City, and to achieve Substantial Completion and Final Completion of the Work within the time or times specified in the Special Conditions. In the event the Work is not completed in the times set forth and as agreed upon, the Contractor further agrees to pay Liquidated Damages to the City as set forth in the Special Conditions. The Contractor acknowledges and recognizes the delays, expenses and difficulties involved in proving in a legal proceeding the actual losses suffered by the City if the work is not completed on time. Accordingly, instead of requiring any such proof, the City and the Contractor agree that as Liquidated Damages for delay, but not as a penalty, the Contractor shall pay to the City the amounts specified in the Special Conditions.

ARTICLE 5

Contract Price and Payment Procedures: The Contractor shall accept as full and complete compensation for the performance and completion of all of the Work specified in this Contract and the Contract Documents, the sum of ??????????????????????????????????????. If this Contract contains unit price pay items, the Contract Price shall be adjusted in accordance with the actual quantities of items completed and accepted by the City at the unit prices quoted in the Bid Form. The amount of the Contract Price is and has heretofore been appropriated by the City Council of the City of Grand Junction for the use and benefit of this Project. The Contract Price shall not be modified except by Change Order or other written directive of the City. The City shall not issue a Change Order or other written directive which requires additional work to be performed, which work causes the aggregate amount payable under this Contract to exceed the amount appropriated for this Project, unless and until the City provides Contractor written assurance that lawful appropriations to cover the costs of the additional work have been made. Written assurance shall be provided in the form of a letter signed by the Public Works Director and certified by the Director of Finance.

Unless otherwise provided in the Special Conditions, monthly partial payments shall be made as the Work progresses. Applications for partial and Final Payment shall be prepared by the Contractor and approved by the City in accordance with the General Contract Conditions.

Upon Final Completion of the Work under the Contract and before the Contractor shall receive final payment, the City shall publish at least twice in a newspaper of general circulation published in the City a notice that: 1. the City has accepted such Work as completed according to the Contract Documents; 2. the Contractor is entitled to final payment therefor; 3. thirty days after the first publication, specifying the exact date, the City shall pay the full balance due under the Contract; and 4. persons having claims for labor, materials, team hire, sustenance, provisions, provender, or other supplies used or consumed by the Contractor or a subcontractor shall file a verified statement of the amount due and unpaid on account of such claim prior to the date specified for such payment. Nothing herein shall be construed as relieving the Contractor and the Sureties on the Contractor's Bonds from any claim or claims for work or labor done or materials or supplies furnished in the execution of the Contract.

ARTICLE 6

Bonds: The Contractor shall furnish currently herewith the Bonds required by the Contract Documents, such Bonds being attached hereto. The Performance Bond shall be in an amount not less than one hundred percent (100%) of the Contract Price set forth in Article 5. The Payment Bond shall be in an amount not less than one hundred (100%) of the Contract Price set forth in Article 5. Bonds in the amounts of \$1,000 or less will be made in multiples of \$100; in amounts exceeding \$5,000, in multiples of \$1,000; provided that the amount of the Bonds shall be fixed by the City at the lowest sum that fulfills all conditions of the Contract.

ARTICLE 7

Contract Binding: The City and the Contractor each binds itself, its partners, successors, assigns and legal representatives to the other party hereto in respect to all covenants, agreements and obligations contained in the Contract Documents. The Contract Documents constitute the entire agreement between the City and Contractor and may only be altered, amended or repealed by a duly executed written instrument. Neither the City nor the Contractor shall, without the prior written consent of the other, assign or sublet in whole or in part its interest under any of the Contract Documents and specifically, the Contractor shall not assign any moneys due or to become due without the prior written consent of the City.

ARTICLE 8

Severability: If any part, portion of provision of the Contract shall be found or declared null, void or unenforceable for any reason whatsoever by any court of competent jurisdiction or any governmental agency having the authority thereover, only such part, portion or provision shall be effected thereby and all other parts, portions and provisions of the Contract shall remain in full force and effect.

IN WITNESS WHEREOF, the City of Grand Junction, Colorado, has caused this Contract to be subscribed by its City Manager and sealed and attested by its City Clerk in its behalf; and the Contractor has signed this Contract the day and the year first mentioned herein.

The Contract is executed in four counterparts.

THE CITY OF GRAND JUNCTION, COLORADO

By: _____
City Manager

Date

ATTEST:

SEAL:

By: _____
City Clerk

????????????????????????????????

By: _____
Title

Date

ATTEST:

CORPORATE SEAL:

By: _____
Title

PERFORMANCE BOND

KNOW ALL MEN BY THESE PRESENTS, that we, the undersigned _____, a _____ organized under the laws of the State of _____, hereinafter referred to as the "Contractor" and _____, a corporation organized under the laws of the State of _____, and authorized and licensed to transact business in the State of Colorado, hereinafter referred to as the "Surety," are held and firmly bound unto the City of Grand Junction, Colorado, hereinafter referred to as the "City", in the penal sum of _____ dollars (\$ _____), lawful money of the United States of America, for the payment of which sum the Contractor and Surety bind themselves and their heirs, executors, administrators, successors and assigns, jointly and severally by these presents.

WHEREAS, the above Contractor has on the _____ day of _____, 200____, entered into a written contract with the City for furnishing all labor, materials, equipment, tools, superintendence, and other facilities and accessories for the construction of _____ (the "Project") and Contract No. _____, if appropriate, in accordance with the Contract, Special Conditions, Special Provisions, General Contract Conditions, Contract Drawings, Specifications and all other Contract Documents therefor which are incorporated herein by reference and made a part hereof, and are herein referred to as the "Contract".

NOW, THEREFORE, the conditions of this performance bond are such that if the Contractor:

1. Promptly and faithfully observes, abides by and performs each and every covenant, condition and part of said Contract, including, but not limited to, its warranty provisions, in the time and manner prescribed in the Contract, and
2. Pays the City all losses, damages (liquidated or actual, including, but not limited to, damages caused by delays in performance of the Contract), expenses, costs and attorneys' fees, that the City sustains resulting from any breach or default by the Contractor under the Contract,

then this bond is void; otherwise, it shall remain in full force and effect.

IN ADDITION, if said Contractor fails to duly pay for any labor, materials, team hire, sustenance, provisions, provender, or any other supplies used or consumed by said Contractor or its subcontractors in its performance of the Work contracted to be done or fails to pay any person who supplies rental machinery, tools, or equipment, all amounts due as the result of the use of such machinery, tools or equipment in the prosecution of the work, the Surety shall pay the same in an amount not exceeding the amount of this obligation, together with interest at the rate of eight percent per annum.

PROVIDED FURTHER, that the said Surety, for value received, hereby stipulates and agrees that any and all changes in the Contract or compliance or noncompliance with the formalities in the Contract for making such changes shall not affect the Surety's obligations under this bond and the Surety hereby waives notice of any such changes. Further, Contractor and Surety acknowledge that the penal sum of this bond shall increase in accordance with approved changes to the Contract Documents without obtaining the Surety's consent up to a maximum of 20 percent of the penal sum. Any additional increases in the penal sum shall require the Surety's consent.

IN WITNESS WHEREOF, said Contractor and said Surety have executed these presents as of this _____ day of _____, 200__.

CONTRACTOR: _____

By: _____

Title: _____

ATTEST: _____

Secretary

SURETY: _____

By: _____

Title: _____

(Accompany this Bond with the attorney-in-fact's authority from the surety to execute this Bond, certified to include the date of the Bond.)

PAYMENT BOND

KNOW ALL MEN BY THESE PRESENTS, that we, the undersigned _____
_____, a _____ organized under the laws of the State
of _____, hereinafter referred to as the "Contractor" and _____
_____, a corporation organized under the laws of the State of
_____, and authorized and licensed to transact business in the State of Colorado,
hereinafter referred to as the "Surety," are held and firmly bound unto the City of Grand
Junction, Colorado, hereinafter referred to as the "City," in the penal sum of _____
_____ dollars (\$ _____), lawful money of the United States of America, for the
payment of which sum the Contractor and Surety bind themselves and their heirs, executors,
administrators, successors and assigns, jointly and severally, firmly by these presents.

WHEREAS, the above Contractor has on the _____ day of _____, 200____,
entered into a written contract with the City for furnishing all labor, materials, equipment, tools,
superintendence, and other facilities and accessories for the construction of _____
_____ (the "Project") and Contract
No. _____, if appropriate, in accordance with the Contract, Special Conditions, Special
Provisions, General Contract Conditions, Contract Drawings, Specifications and all other
Contract Documents therefor which are incorporated herein by reference and made a part hereof,
and are herein referred to as the "Contract".

NOW, THEREFORE, the condition of this payment bond obligation is such that if the
Contractor shall at all times promptly make payments of all amounts lawfully due to all persons
supplying or furnishing it or its subcontractors with labor, materials, rental machinery, tools or
equipment, used or performed in the prosecution of work provided for in the above Contract and
shall indemnify and save harmless the City to the extent of any and all payments in connection
with the carrying out of such Contract which the City may be required to make under the law,
and for all losses, damages, expenses, costs, and attorneys' fees incurred by the City resulting
from the failure of the Contractor to make the payments discussed above, then this obligation
shall be null and void, otherwise, it shall remain in full force and effect.

PROVIDE FURTHER, that the said Surety, for value received, hereby stipulates and
agrees that any and all changes in the Contract Documents, or compliance or noncompliance
with the formalities in the Contract for making such changes shall not affect the Surety's
obligations under this bond and the Surety hereby waives notice of any such changes. Further,
Contractor and Surety acknowledge that the penal sum of this bond shall increase or decrease in

accordance with approved changes to the Contract Documents without obtaining the Surety's consent up to a maximum of 20 percent of the penal sum. Any additional increases in the penal sum shall require the Surety's consent.

IN WITNESS WHEREOF, said Contractor and said Surety have executed these presents as of this _____ day of _____, 200__.

CONTRACTOR: _____

By: _____

ATTEST: _____

Secretary

Title: _____

SURETY: _____

By: _____

Title: _____

(Accompany this Bond with the attorney-in-fact's authority from the surety to execute this Bond, certified to include the date of the Bond.)



PUBLIC WORKS
& PLANNING

NOTICE TO PROCEED

Date:

Contractor:

Project:

Purchase Order #:

In accordance with the contract dated ?, the Contractor is hereby notified to begin work on the Project on or before ?. The time of completion shall be ? calendar days from the stated beginning date.

The date of completion as determined from the stated date and time is ?.

CITY OF GRAND JUNCTION, COLORADO

?, Project Engineer

CONTRACTOR ACKNOWLEDGEMENT

Receipt of this Notice to Proceed is hereby acknowledged:

Contractor:

By: _____

Title: _____

Date: _____



PUBLIC WORKS
& PLANNING

WORK CHANGE REQUEST

The Engineer may desire to make a change in the Work described in the Contract Documents. This form shall be used to inform the Contractor of desired changes, and to direct the Contractor to submit a Request for Adjustment. If the time required for preparation and execution of a formal Change Order would result in delay or stoppage of the Work, or would allow a hazardous condition to exist, the Engineer may authorize and direct the Contractor to proceed with the changes described.

Project:

To:

From: City of Grand Junction

Description of and justifications for change (attach supporting documents if necessary)

Recommended method of payment (Reference is made to Section VIII of the General Conditions):

- Unit Price(s) in Bid Schedule
- Unit Price(s) to be agreed upon and set forth in a Change Order or included under the Force Account Item
- Cost plus 15%
- Lump Sum to be agreed upon and set forth in a Change Order or included under the Force Account Item

Recommended adjustment in Contract Time:

- Contractor is directed to submit a Request for Adjustment for but not proceed with the proposed changes described above.
- Contractor is directed to submit a Request for Adjustment and is authorized to proceed with the changes described above.

Project Manager	Date
-----------------	------

The Contractor acknowledges:

- that this is not a formal Change Order;
- that recommended methods of Contract Price and Contract Time adjustment are not binding;
- that a formal Change Order shall follow if changes are to be made;
- that any additional work performed by the Contractor unless directed otherwise above shall be at his expense, for which compensation is not due and will not be paid; and
- that a Request for Adjustment for the above changed work must be submitted within five Working Days.

Contractor's representative	Title	Date
-----------------------------	-------	------



PUBLIC WORKS
& PLANNING

WORK CHANGE AUTHORIZATION

This form shall be used to authorize the Contractor to proceed with changes and/or additional work as described in a *Request for Adjustment* submitted by the Contractor:

Project _____
To: _____
From: City of Grand Junction

Reference Documents

	<u>Issued by</u>	<u>Dated</u>
Request for Adjustment No. _____	_____	_____
___ Field Order	_____	_____
___ Work Change Request	_____	_____

Description of changes and additional work (attach supporting documents if necessary):

Method of payment (reference is made to Section VIII of the General Conditions):

- ___ Unit Price(s) in Bid Schedule
- ___ Unit Price(s) as agreed upon and to be set forth in a Change Order
- ___ Unit Price(s) as agreed upon and to be included under the Force Account Item.
- ___ Cost plus 15% to be set forth in a Change Order.
- ___ Cost plus 15% to be included under the Force Account Item.
- ___ Lump Sum as agreed upon and to be set forth in a Change Order
- ___ Lump Sum as agreed upon and to be included under the Force Account Item

Adjustment in Contract Time _____

The City and the Contractor acknowledge:

- that methods of Contract Price and Contract Time adjustment as set forth above are binding.
- that a formal Change Order will follow if the changes and/or additional work are not to be included under the Force Account Item; and,
- that any additional work performed by the Contractor unless directed otherwise shall be at his expense for which compensation is not due and will not be paid.

Project Manager

Date

Contractor's representative

Title

Date



PUBLIC WORKS
& PLANNING

CHANGE ORDER NO. ?

Date: ?

To: ?

From: City of Grand Junction
Department of Public Works and Planning
?, Project Engineer

Project: ?

Purchase Order #: ?

It is agreed to modify the Contract for the Project as follows:
?

Summary of Contract price adjustments: Price adjustments are itemized on the attached sheet(s).

Original Contract Amount	\$?
Approved Change Orders	0.00
This Change Order	<u>?</u>
Revised Contract Amount	<u>\$?</u>

Summary of Contract time adjustments:

Original Contract Time	? days
Approved Change Orders	? days
This Change Order	<u>? days</u>
Revised Contract Time	? days
Original Completion Date	?
Revised Completion Date	?

This modification constitutes compensation in full for all costs and mark-ups directly and/or indirectly attributable to the changes ordered herein, for all delays, impacts and disruptions related thereto and for performance of the changes within the Contract Time.

City of Grand Junction

Prepared by: _____ Title: _____ Date: _____

Recommended by: _____ Title: _____ Date: _____

Approved by: _____ Title: _____ Date: _____

Contractor: ?

Accepted by: _____ Title: _____ Date: _____

Certificate For Payment

City of Grand Junction, Department of Public Works

Project: _____
 Contractor: _____
 Pay Estimate No.: _____
 Pay Period: _____ Purchase Order No. _____

Original Contract Total	\$	0.00
Change Orders [none]		0.00
Current Contract Total	\$	0.00

Earnings:

Previous amount earned	\$	0.00	
Amount earned this period		0.00	
Total earned to date	\$	0.00	0% of Contract Amount
Less retainage: x of amount earned		(0.00)	
Less previous payments		(0.00)	
Current Amount Due:	\$	0.00	

Account: _____ - _____ - _____ - _____

Contract Progress:

Contract time start date _____ End date: _____

Original time:	0	Cal. Days
Time adjustments:	0	Cal. Days
Total time:	0	Cal. Days

Time used: _____ 0 Cal. Days 0% of Contract Time

This Certificate of Payment was prepared for the City of Grand Junction, Colorado

Prepared by: _____ Date: _____

Approved by: _____ Date: _____

The undersigned Contractor certifies that all previous progress payments received from the City under this contract have been applied by the undersigned to discharge all obligations incurred in connection with the Work and that the Work covered by this Certificate for Payment has been completed in accordance with the Contract Documents.

Contractor: _____

Certified by: _____ Date: _____



PUBLIC WORKS
& PLANNING

NOTICE OF SUBSTANTIAL COMPLETION

Project: ?

Contractor: ?

Date of Contractor's request for issuance of Notice of Substantial Completion ?

As a result of an inspection conducted on _____, 200_, the above referenced Project was found to be Substantially Complete. The items listed on the attached Punch List were identified during the inspection and must be completed prior to the Contractor's application for Final Acceptance of the Project.

City of Grand Junction

By: _____ Date

- cc: Surety - ?
- Trent Prall, Engineering Manager
- Don Newton, Engineering Projects Manager
- Bret Guillory, Utilities Engineer
- Walt Hoyt, Construction Supervisor
- ?, Construction Inspector
- Project File



PUBLIC WORKS
& PLANNING

NOTICE OF PARTIAL ACCEPTANCE

Date:

Contractor:

Project:

Description of the units of Work being accepted.

Date of Inspection of completed Work: _____, 200_

The City of Grand Junction has determined that the Work referenced above is substantially complete and that there is benefit to the City to place those units of work in service prior to completion of the entire Project. Therefore, the Work is hereby accepted for future operation and maintenance by the City. In accordance with Article XI, Section 76 of the General Contract Conditions, the Contractor shall warrant the work for a period of one year after the date of acceptance, which is _____, 200_.

This Partial Acceptance of Work shall not exempt the Contractor from completing all remaining Work described in the Contract Documents.

City of Grand Junction:

By: _____

Date: _____

cc: Surety - ?

Trent Prall, Engineering Manager

Don Newton, Engineering Projects Manager

Bret Guillory, Utilities Engineer

Walt Hoyt, Construction Supervisor

?, Construction Inspector

Project File



PUBLIC WORKS
& PLANNING

NOTICE OF FINAL ACCEPTANCE

Project: ?

Contractor: ?

Date of final completion: ?

End of warranty period: ?

The Contractor is hereby notified that the Project referenced above has been completed and is hereby accepted for future operation and maintenance by the City of Grand. In accordance with Article XI, Section 76 of the General Contract Conditions, the Contractor shall warrant all work for a period of one year after the date of acceptance. The date of Final Acceptance and beginning of the Contractor’s warranty of all work not previously accepted is _____, 200 ____.

City of Grand Junction

? Project Engineer:

Date: _____

cc: Surety - ?
Trent Prall, Engineering Manager
Don Newton, Engineering Projects Manager
Bret Guillory, Utilities Engineer
Walt Hoyt, Construction Supervisor
?, Construction Inspector
Project File

NOTICE OF FINAL PAYMENT

Notice is hereby given that ?, the Contractor for the construction of ?, has completed the work specified in the Contract dated ? and that the work has been accepted by the City of Grand Junction.

Notice is further given that final payment for the work will be made to the Contractor on or after ?, being at least thirty days after the first publication of this notice.

Any person having a claim for labor or materials furnished under this Contract shall present the same in writing to the City of Grand Junction at the following address, prior to the date specified above:

City of Grand Junction
Department of Public Works and Planning
Attn: ?, Project Engineer
250 North 5th Street
Grand Junction, CO 81501

CITY OF GRAND JUNCTION, COLORADO

Stephanie Tuin, City Clerk

First publication: ?
Second publication: ?



PUBLIC WORKS
& PLANNING

FINAL RECEIPT AND RELEASE

Project:

Contractor:

Final Contract Price: \$

Final Payment: \$

The Contractor hereby certifies:

THAT the above noted "Final Contract Price" is the full compensation due under the Contract for the Project;

THAT the above noted "Final Payment" has been received from the City of Grand Junction; THAT, together with the "Final Payment", amounts totaling the "Final Contract Price" have been received from the City of Grand Junction;

THAT the City of Grand Junction is released from all claims related to the Contract for the Project; and

THAT all persons and companies performing labor or furnishing materials for the Project have been paid in full.

Contractor:

By: _____

Title: _____

Date: _____

ENGINEERING DIVISION



GENERAL CONTRACT CONDITIONS

REVISED JULY, 2010

CITY OF GRAND JUNCTION, COLORADO
DEPARTMENT OF PUBLIC WORKS AND PLANNING
ENGINEERING DIVISION

GENERAL CONTRACT CONDITIONS

TABLE OF CONTENTS

I. GENERAL1

1. Scope.....1

2. Titles and Subheadings.....1

3. Definitions and Terms.....1

II. LAWS, PERMITS AND LABOR EMPLOYMENT7

4. Laws and Ordinances.....7

5. Permits and Licenses.....7

6. Patents.....7

7. Air and Water Quality Control.....7

8. Employment of Labor8

9. Affirmative Action/Eeo8

III. INTENT, CORRELATION AND INTERPRETATION OF CONTRACT DOCUMENTS9

10. Intent of Contract Documents9

11. No Oral Agreements9

12. Coordination of Contract Documents.....9

13. No Waiver of Rights10

14. Shop Drawings.....10

15. Estimated Quantities In Bid Schedules.....10

IV. BONDS, INDEMNIFICATION AND INSURANCE11

16. Performance, Payment, and Other Bonds11

17. Insurance Requirements.....11

18. Contractor's Insurance14

19. Indemnification14

V. CONTRACTOR'S RESPONSIBILITIES - SAFETY15

20. Safety and Protection.....15

21. Emergencies15

22. Blasting and Other Hazardous Work16

23. Excavations16

24. Traffic Maintained Over Construction16

25. Traffic Control, Street Closures and Detours.....16

City of Grand Junction, Colorado
Table of Contents; General Contract Conditions

SECTION	PAGE
26. Maintenance of Access and Services	18
VI. CONTRACTOR'S RESPONSIBILITIES - GENERAL.....	19
27. Beginning, Progress and Time of Completion	19
28. Schedules.....	19
29. Schedule of Values	19
30. Examination of Contract Documents and Work.....	20
31. Subsurface Conditions	20
32. Shop Drawings and Submittals	20
33. Tests.....	22
34. Record Drawings.....	22
35. Supervision and Superintendence	22
36. Working Days and Hours	22
37. Protecting and Relocating Utilities	22
38. Labor, Materials and Equipment	24
39. Character of Workers	25
40. Construction Equipment.....	25
41. Methods of Operation.....	25
42. Cooperation of Contractor	26
43. Neglected or Defective Work	27
44. Work by Others	27
45. Payment for Labor and Materials.....	28
46. Public Relations and Notifications.....	28
47. Protection and Restoration of Property and Landscape	29
48. Cleaning Up.....	30
49. Assignment or Subletting	30
50. Excess Material.....	31
51. Stockpiling Materials and Equipment.....	31
52. Operations, Staging and Use of Private Utilities	31
53. Survey Reference Points	32
54. Construction Surveying and "As-Built" Drawings.....	32
55. Weekly Meetings.....	33
56. Newsletter	33
57. Trash Collection	33
58. Mail Delivery Service.....	33
VII. CITY'S RESPONSIBILITIES.....	34
59. Availability of Lands.....	34
60. Authority of the City Manager.....	34
61. Authority of the City Engineer and Project Engineer.....	34
62. Limitations on Engineer's Responsibilities	35
63. Clarifications and Interpretations.....	35
64. Orders To Contractor's Agent	35
65. Authority and Duties of Inspectors	35
66. Inspection of Work.....	36
67. Deviation Allowed.....	38
68. Preconstruction Meeting	38

City of Grand Junction, Colorado
Table of Contents; General Contract Conditions

SECTION	PAGE
VIII. CHANGES IN WORK OR CONTRACT PRICE	39
69. Allowance for Change	39
70. Limitations and Conditions of Change	39
71. Required Change of Work Forms	40
72. Extension of Contract Time	45
73. Delays and Liquidated Damages	46
X. CLAIMS	48
74. Notice of Intent to Claim	48
75. Submittal of Claim	48
XI. WARRANTY AND GUARANTEE	51
76. Contractor's Warranty and Guarantee	51
XII. MEASUREMENT, PAYMENT AND ACCEPTANCE	53
77. General Measurement and Payment Issues	53
78. Partial Payments	53
79. Retainage	54
80. Notice of Substantial Completion	54
81. Final Estimate and Payment	55
82. Acceptance of Work	56
83. Suspension of Work	57
84. Contract Default and Termination of Contract by City	57
XIV. TERMINATION FOR CONVENIENCE	59
85. Termination of Contract for Convenience	59
XV. DISPUTES	61
86. Disputes with the City	61
87. Unresolved Disputes	61
XVI. TAXES	63
88. Sales and Use Taxes	63
89. Accounting of Costs and Audit	63

CITY OF GRAND JUNCTION, COLORADO
DEPARTMENT OF PUBLIC WORKS AND PLANNING
ENGINEERING DIVISION

GENERAL CONTRACT CONDITIONS

I. GENERAL

1. Scope

The following conditions are general in scope and may contain requirements covering conditions that may not be encountered in the performance of the Work under contract. Where any stipulation or requirement set forth herein applies to any such non-existing condition, and is not applicable to the Work under contract, such stipulation or requirement shall have no meaning relative to the performance of said Work.

2. Titles and Subheadings.

I. The titles and subheadings used in the Contract Documents are for convenience of reference only and shall not be taken or considered as having any bearing on the interpretation of said documents.

II. Titles used in these specifications having a masculine gender, such as "workman" and the pronouns "he" or "his," are for the sake of brevity and are intended to refer to persons of either sex.

3. Definitions and Terms.

I. When the Contract indicates that work shall be "accepted, acceptable, approval, approved, authorized, condemned, considered necessary, contemplated, deemed necessary, designated, determined, directed, disapproved, established, given, indicated, insufficient, interpretation, interpreted, ordered, permitted, rejected, required, reserved, satisfactory, specified, sufficient, suitable, suspended, unacceptable, or unsatisfactory," it shall be understood that these expressions are followed by the words "by the City," or "to the City."

II. Additional definitions and terms are provided in Section 101 of the City's Standard Specifications for Road and Bridge Construction. Wherever the following terms are used in these Contract General Conditions, or other Contract Documents, the intent and meaning shall apply to both the singular and plural thereof and shall be interpreted as follows:

Addenda. Written or graphic instruments issued prior to Bid Opening which clarify, correct, or change the Contract Documents.

Bid. The offer or proposal of the Bidder submitted on the prescribed form setting forth the prices for the Work to be performed.

Bidder. An individual, firm, corporation, or other legal entity submitting a proposal for the advertised Work and, if the Successful Bidder, a contractor intending to contract with the City for performance of prescribed Work.

City of Grand Junction, Colorado
General Contract Conditions

Bid Documents. These shall consist of the following forms and documents: Construction Drawings, Addenda (if any), Invitation To Bid, Instruction To Bidders, Bid Form, Bid Bond Form, Special Conditions, Special Provisions, Supplemental Specifications, Appendix, and Construction Drawings (not attached).

Bid Opening. The public opening and reading of all bids prepared and submitted in accordance with the Instructions To Bidders at the time and date set forth in the Invitation To Bid.

Bid Guaranty. The security, as designated in the Instructions To Bidders and furnished with the Bid as a guaranty that the Bidder shall enter into the Contract and furnish the Bonds and Certificates of Insurance as required if awarded the Work.

Bid Schedule. A list of Bid Items in the Bid Form, which includes a description, approximate quantity and units (if any), unit price and extended amount or lump sum bid, for each item. The Bid Schedule also includes a line for the Total Bid based on the summation of the extended amounts of all bid items. The Bid Schedule may also include bid alternates and a line for the Bidder to enter an estimated date to begin construction.

Bonds. Bid, Performance and Payment Bonds and other instruments of security.

Calendar Day. Each and every day shown on the calendar, beginning and ending at midnight.

Change of Work Form. The following forms, copies of which are provided in the Standard Forms: Field Order, Work Change Request, Request for Adjustment, and Change Order.

Change Order. A document recommended by the City which is signed by the Contractor and by an authorized agent of the City which authorizes an addition, deletion, or revision in the Work, or an adjustment in Contract Price or Contract Time, which is issued on or after the Effective Date of the Contract. Properly executed Change Orders become a part of the Contract Documents.

City. The City of Grand Junction, State of Colorado, or any employee thereof.

City Engineer. Title has been changed to Engineering Manager.

Construction Drawings (Drawings, Plans). The Drawings or Plans which show the character and scope of the Work to be performed which have been prepared or approved by the City and are referred to in the Contract Documents (including Standard Details).

Contract. A written agreement between the City and Contractor covering the Work to be performed. Other Contract Documents are attached to the Contract and made a part thereof as provided therein.

City of Grand Junction, Colorado
General Contract Conditions

Contract Documents. The Standard Contract Documents for Capital Improvements Construction (current edition) and the Bid Documents as defined herein. Contract Documents also include: Shop Drawings, Field Orders, Work Change Requests and Change Orders which must be signed by authorized representatives of the City and the Contractor.

Contract Time. The number of Calendar days allowed for the Substantial and/or Final completion of the Work specified in the Contract including authorized time extensions, beginning on the date specified in the Notice to Proceed.

Contractor. The person, firm, or corporation with whom the City intends to or has entered into a Contract.

Day. Calendar Day.

Defective Work. Work that is unsatisfactory, faulty, or deficient, or does not conform to the Contract Documents, or does not meet the requirements of a referenced standard, test, or approval referred to in the Contract Documents, or has been damaged prior to the City's recommendation of Final Payment (unless responsibility for the protection thereof has been assumed by the City at Substantial Completion).

Drawings. Same meaning as Construction Drawings.

Effective Date. The date indicated in an agreement or notice on which it becomes effective, but if no such date is indicated, the date on which the instrument is fully signed and delivered by the last of the parties involved.

Engineer. The Project Engineer, who may be a City employee or hired consultant who has been appointed or authorized by the City to oversee the technical aspects of the work and to administer the Contract on behalf of the City. The term "Engineer" may also apply to a Professional Engineer hired by a developer to design and/or administer the construction of public infrastructure in accordance with a development approved by or contracted for/or with the City.

Engineering Manager. Engineer employed by the City responsible for all construction contact decisions.

Extra or Additional Work. Work which was not a part of the original Contract Documents at the time the Contract was executed for which extra compensation or time is justified in accordance with conditions set forth in the Contract Documents.

Field Order. A written order issued by the City which directs or allows minor changes in the Work, and which does not involve a change in the Contract Price or Contract Time.

Final Completion. The date upon which the Work, in the City's opinion and based upon its inspection, is acceptable and fully performed in accordance with the Contract Documents, and all other requirements or conditions to the City's advertisement of the Project for final payment have been fulfilled. Final Completion shall be evidenced by the City's issuance of a Letter of Final Completion.

City of Grand Junction, Colorado
General Contract Conditions

Holidays. Holidays recognized by the City are:

New Year's Day.....	January 1
Washington's Birthday.....	Third Monday in February
Memorial Day.....	Last Monday in May
Independence Day.....	July 4
Labor Day.....	First Monday in September
Veteran's Day.....	November 11
Thanksgiving Day.....	Fourth Thursday in November
Christmas Day.....	December 25

When a Holiday, as listed above, falls on a Saturday, it shall be observed on the preceding Friday; if the Holiday falls on Sunday, it shall be observed on the following Monday.

Inspector. An authorized representative of the City, assigned to inspect and/or test materials furnished or Work performed by the Contractor.

Laboratory. Any testing laboratory designated by the City to make tests of the materials and Work involved in the Contract.

Liquidated Damages. The sum of money the Contractor agrees to pay the City for each day of delay beyond the date due for the completion of specified stages of Work or the complete Contract, or in delaying or requiring the City to incur additional costs in the process of obtaining a Contract to perform the Work in the case of Bid Guaranty.

Manager. The City Manager of the City of Grand Junction.

Notice of Award. The written notice by City to the apparent Successful Bidder stating that upon compliance with the conditions precedent enumerated therein, within the time specified, City shall sign and deliver the Contract.

Notice to Proceed. Written notice to the Contractor to proceed with the Contract Work specifying, when applicable, the date of beginning of Contract Time.

Plans. Same meaning as Construction Drawings.

Project. The specific Work to be performed as described in the Contract Documents.

Request for Adjustment. A written request issued by the Contractor for an adjustment in Contract Time or Contract Price. A copy of the Request For Adjustment Form is provided in the Standard Forms.

Review. To examine or re-examine for conformance with the Contract Documents.

Schedule of Submittals. A schedule of all Shop Drawings, material certifications, mix designs, samples, construction schedules (Gantt charts) and other items to be submitted by the Contractor for review and/or approval by the City. The Schedule of Submittals is

City of Grand Junction, Colorado
General Contract Conditions

included in the Special Conditions and may be modified by the City any time before or after the construction begins.

Shop Drawings (Work Drawings). All drawings, diagrams, illustrations, schedules, and other data which are specifically prepared by or for the Contractor to illustrate some portion of the Work, and all illustrations, brochures, standards, schedules, performance charts, illustrations, diagrams, and other information submitted by the Contractor to illustrate material or equipment for some portion of the Work.

Special Conditions. The part of the Contract Documents which amends or supplements the General Contract Conditions and which are specific to the Work to be performed.

Special Provisions. Additions and revisions to the City's Standard Specifications covering conditions peculiar to an individual project. Special Provisions may be a section in the Bid Documents, may appear as notes on the Construction Drawings, or both.

Specifications. Those portions of the Contract Documents consisting of written technical descriptions of materials, equipment, standards and workmanship as applied to the Work. These may consist of Standard or Supplemental Specifications, Special Provisions, and/or notes on the Construction Drawings.

Standard Contract Documents for Capital Improvements Construction. These shall include the following Standard Forms and documents: Statement of Bidders Qualifications, Instructions to Contractors Regarding Affirmative Action, Notice of Award, Contract, Performance Bond Form, Payment Bond Form, Notice to Proceed, Field Order Form, Work Change Request Form, Request for Adjustments Form, Change Order Form, Partial Payment Request Form, Certificate for Payment Form, Final Receipt and Release, General Contract Conditions, Standard Specifications for Road and Bridge Construction, and Standard Specifications for Construction of Water Lines, Sanitary Sewers, Storm Drains, Underdrains and Irrigation Systems.

Standard Details. Same meaning as Standard Drawings.

Standard Drawings. City-adopted Standard Drawings and Details which pertain to the Work to be performed.

Standard Forms. Forms provided in the Standard Contract Documents For Capital Improvements Construction, which are in the format to be used for the stated or intended purpose.

Standard Specifications. Standard Specifications For Road and Bridge Construction and Standard Specifications For Construction of Water Lines, Sanitary Sewers, Storm Drains, Underdrains, and Irrigation Systems, both of which are included in the Standard Contract Documents for Capital Improvements Construction.

Subcontractor. An individual firm, corporation, or other legal entity to which the Contractor subcontracts part of the Contract.

City of Grand Junction, Colorado
General Contract Conditions

Substantial Completion. When the Work or a specified part thereof has progressed to the point where the Work, in the opinion of the City, as evidenced by the City's Letter of Substantial Completion, is sufficiently complete, in accordance with the Contract Documents, so that the Work or specialized part can be placed in service and utilized for the purpose for which it is intended. The terms "substantially complete" and "substantially completed" as applied to any Work refer to Substantial Completion thereof.

Successful Bidder. The actual or apparent responsive, responsible and qualified Bidder having the lowest Bid price.

Superintendent. The Contractor's authorized representative who is in responsible charge of the Work.

Supplemental Specifications. Additional Specifications which may be necessary to cover Work peculiar to an individual project, which is not addressed by the Standard Specifications. Supplemental Specifications may be a section in the Bid Documents or may appear as notes on Construction Drawings.

Surety. The corporation, partnership or individual, other than the Contractor, executing a bond furnished by the Contractor.

Work. All labor, materials, equipment, and incidentals necessary to successfully complete the project according to all duties and obligations imposed by the Contract.

Work Change Request. A written directive to the Contractor, issued by the Engineer on or after the Effective Date of the Contract, requesting the Contractor to provide a cost for pending extra Work or changes in the Work. The Work Change Request may also direct the Contractor to proceed with the revision in Work. A Work Change Request does not change the Contract Price or Contract Time, but is evidence that the parties expect that the change directed or documented by a Work Change Request shall be, if implemented, incorporated into a subsequently issued Change Order following negotiations by the parties as to its effect, if any, on the Contract Price or Contract Time.

Working Day. Any Day, exclusive of Saturdays, Sundays and City-observed Holidays.

II. LAWS, PERMITS AND LABOR EMPLOYMENT

4. Laws and Ordinances

The Contractor shall at all times observe and comply with the provisions of the Laws, Ordinances, Rules, Codes, and Regulations of the City of Grand Junction, the State of Colorado and The United States of America, which in any manner limit, control or apply to the actions or operations of the Contractor, its Subcontractors, or its or their employees, agents and servants, engaged in performing the Work or affecting the materials supplied to or by them.

5. Permits and Licenses

Unless specified otherwise in the Special Conditions, the Contractor shall secure and pay for all permits and licenses and shall pay all governmental charges and inspection fees necessary for the prosecution of the Work, which are applicable at the time of the Bid.

6. Patents

The Contractor shall perform all Work in compliance with all applicable patent, trademark and copyright laws, rules, regulations and codes of the United States. The Contractor shall not utilize any design, device, material or process, protected by patent, trademark or copyright, in performance of the Work unless the Contractor has obtained proper permission and all releases and other necessary documents. The Contractor shall determine if any material, equipment, process or procedure specified in the Construction Drawings is protected. The Contractor and the Surety shall release, indemnify and save harmless the City, its officers, agents and employees from any and all claims, damages, suits, costs, expenses, liabilities, actions or proceedings of any kind or nature of or by anyone whomsoever, resulting from infringement of any patent, trademark, copyright or other right protected by law.

7. Air and Water Quality Control

I. The Contractor shall comply with the Colorado Air Quality Control Act, 25-7-101 *et seq.* C.R.S. and regulations promulgated thereunder.

II. The Contractor shall comply with the Colorado Water Quality Control Act, 25-8-101 *et seq.* C.R.S.; Protection of Fishing Streams, 33-5-101 *et seq.* C.R.S.; Clean Water Act, 33 USC 1251 *et seq.*; regulations promulgated thereunder; certifications issued; and with all other requirements of Section 107.25 of the Colorado Department Of Transportation Standard Specifications of Road and Bridge Construction.

III. The cost of controlling pollution shall be included in the Bid item expected to cause it unless specifically listed as a separate pay item and shall not be the subject of extra or additional payment.

IV. Should the Contractor, or its subcontractors, fail to control pollution, the City shall have the right to employ outside assistance, City employees, and/or a private contractor to provide control as necessary. Any cost incurred by the City in controlling pollution caused by the Contractor or entities under control of the Contractor or for whose actions the Contractor is responsible, including engineering, shall be paid for by the Contractor.

City of Grand Junction, Colorado
General Contract Conditions

8. Employment of Labor

I. The Contractor shall hold the City harmless from any violation of any or all provisions of law, both of the State of Colorado and of the United States, affecting or relating to the employment and compensation of workers, laborers, and mechanics requiring time and one-half or other increased compensation for overtime work or other special treatment of employees. The Contractor shall likewise comply with and protect and hold the City harmless from any violation of all laws and lawful rules and regulations, both of the State of Colorado and of the United States, relating to worker's compensation, unemployment compensation, Social Security and any and all other expenses and conditions of employment under the Contract.

II. The Contractor shall give preference to resident labor in accordance with Article X, Section 8, of the Charter of the City of Grand Junction, Colorado.

III. The Contractor and its Subcontractors shall comply with the Workers' Compensation Act of Colorado and shall provide Compensation Insurance to protect the Contractor, its Subcontractors and the City from and against any and all Workers' Compensation claims arising from performance of the Work under the Contract. The City shall be furnished, as set forth in the Bid Documents, four (4) copies of the certificate or certificates evidencing such insurance to be in effect.

9. Affirmative Action/Eeo

I. On projects funded or partially funded by the Federal or State government, Contractor shall not discriminate against any employee or applicant for employment because of race, color, religion, sex, national origin or disability. On such contracts, the Contractor shall take affirmative action to ensure that applicants are employed and that employees are treated during employment without regard to their race, color, religion, sex, national origin or disability. Such actions shall include, but not be limited to the following: employment, upgrading, demotion or transfer, recruitment or recruitment advertising, layoff or termination, rates of pay or other forms of compensation, selection for training, including apprenticeship. Contractor agrees to post in conspicuous places, available to employees and applicants for employment, notices to be provided, setting forth the provisions of this Equal Opportunity clause.

II. On projects requiring it, the Contractor shall comply with all provisions of Executive Order No. 11246 of September 24, 1965, as amended, and of the rules, regulations and relevant orders of the Secretary of Labor. The Contractor shall be solely and completely responsible for compliance with all applicable laws, rules, regulations and orders adopted or promulgated thereunder.

III. In addition to the foregoing, on projects requiring the Contractor and/or Subcontractor to have a program of affirmative action, three (3) copies of said written programs shall be submitted to the City within ten (10) days after issuance of the Notice of Award or the awarding of each subcontract.

III. INTENT, CORRELATION AND INTERPRETATION OF CONTRACT DOCUMENTS

10. Intent of Contract Documents

The intent of the Contract Documents is to provide for the construction and completion, in every detail, of the Work described in the Contract Documents. The Contractor shall furnish all labor, material, equipment, tools, transportation and supplies required to complete the Work in accordance with the Contract Documents.

11. No Oral Agreements

No oral agreement or conversation with any officer, agent or employee of the City, either before or after the execution of the Contract, shall affect or modify any of the terms, conditions or other obligations set forth in any of the Contract Documents. All contract modifications must be in writing, signed by the authorized agent of the City who is in charge of the administration of this Contract.

12. Coordination of Contract Documents

I. The Specifications and Construction Drawings are intended to supplement, but not necessarily duplicate each other, and together constitute one (1) complete set of drawings and specifications, so that any Work exhibited in the one and not in the other shall be executed as if it had been set forth in both, in order that the Work shall be completed according to the complete design or designs as decided and determined by the City. Should anything be omitted from the Construction Drawings and Specifications which is necessary for a clear understanding of the Work or should it appear that various instructions are in conflict, then the Contractor shall secure written clarification or instructions from the City before proceeding with the construction affected by such omissions or discrepancies.

II. In case of any conflict, inconsistency or discrepancy among the Contract Documents, the requirement defining or describing the higher quality Work or performance shall control. If the conflict, inconsistency or discrepancy cannot be resolved by the application of that rule, the Contract Documents shall be given precedence in the following order: Contract and Notice to Proceed, Addenda, Special Conditions, Instructions To Bidders, General Contract Conditions, Change Orders, Special Provisions and Supplemental Specifications, Construction Drawings and Standard Specifications. Words and abbreviations which have well known technical or trade meanings are used in the Contract Documents in accordance with such recognized meanings. Full-size or large-scale details or drawings shall govern small-scale drawings. Figure dimensions on Drawings shall govern over scale. Any Work that may reasonably be inferred from the Specifications or Construction Drawings as being required to produce the intended result shall be supplied whether or not it is specifically called for. Work materials or equipment described in words which so applied have a well known technical or trade meaning shall be deemed to refer to such recognized standards.

City of Grand Junction, Colorado
General Contract Conditions

13. No Waiver of Rights

No assent or waiver, expressed or implied, to any breach of any one or more of the covenants, provisions and agreements of the Contract Documents shall be deemed or taken to be a waiver of any succeeding or other breach.

14. Shop Drawings

The Construction Drawings shall be supplemented by such Shop Drawings prepared by the Contractor as are necessary or required to adequately define or control the Work. The City must approve Shop Drawings and/or details before any work involving such Drawings shall be performed.

15. Estimated Quantities In Bid Schedules

The quantities noted in the Bid Schedules are approximations for comparing Bids, and no claim shall be made against the City because of excess or deficiency therein, actual or relative. Payment to the Contractor shall be made only for the actual quantities of Work performed and accepted or materials furnished in accordance with the Contract Documents. The scheduled quantities of Work to be done and materials to be furnished may each be increased, decreased, or omitted as hereinafter provided.

IV. BONDS, INDEMNIFICATION AND INSURANCE

16. Performance, Payment, and Other Bonds

I. Contractor shall furnish a Performance Bond and a Payment Bond, each in an amount at least equal to that specified in the Contract, as security for the faithful performance and payment of all Contractor's obligations under the Contract Documents. These Bonds shall remain in effect for the duration of the Warranty Period (as specified in the Special Conditions). Contractor shall also furnish other Bonds that may be required by the Special Conditions. All Bonds shall be in the forms prescribed by the Contract Documents and be executed by such Sureties as are:

- (a) licensed to conduct business in the State of Colorado and
- (b) named in the current list of "Companies Holding Certificates of Authority as Acceptable Sureties on Federal Bonds and as Acceptable Reinsuring Companies" as published in Circular 570 (amended) by the Audit Staff, Bureau of Accounts, U.S. Treasury Department.

II. A certified copy of the Authority to Act must accompany all Bonds signed by an agent. If the Surety on any Bond furnished by the Contractor is declared bankrupt, or becomes insolvent, or its rights to do business in Colorado are terminated, or it ceases to meet the requirements of paragraphs (a) and (b), Contractor shall within five (5) days thereafter substitute another Bond and Surety, both of which shall be acceptable to the City.

17. Insurance Requirements

I. The Contractor agrees to procure and maintain, at its own cost, a policy or policies of insurance sufficient to insure against all liability, claims, demands, and other obligations assumed by the Contractor pursuant to this Section. Such insurance shall be in addition to any other insurance requirements imposed by this Contract or by law. The Contractor shall not be relieved of any liability, claims, demands, or other obligations assumed pursuant to this Section by reason of its failure to procure or maintain insurance, or by reason of its failure to procure or maintain insurance in sufficient amounts, durations, or types.

II. Contractor shall procure and maintain and, if applicable, shall cause any Subcontractor of the Contractor to procure and maintain insurance coverage listed below. Such coverage shall be procured and maintained with forms and insurers acceptable to The City of Grand Junction. All coverage shall be continuously maintained to cover all liability, claims, demands, and other obligations assumed by the Contractor pursuant to this Section. In the case of any claims-made policy, the necessary retroactive dates and extended reporting periods shall be procured to maintain such continuous coverage. Minimum coverage limits shall be as indicated below unless specified otherwise in the Special Conditions:

- (a) Worker Compensation insurance to cover obligations imposed by applicable laws for any employee engaged in the performance of work

City of Grand Junction, Colorado
General Contract Conditions

under this Contract, and Employers' Liability insurance with minimum limits of:

FIVE HUNDRED THOUSAND DOLLARS (\$500,000) each accident,
FIVE HUNDRED THOUSAND DOLLARS (\$500,000) disease - policy limit, and
FIVE HUNDRED THOUSAND DOLLARS (\$500,000) disease - each employee.

- (b) General Liability insurance with minimum combined single limits of:

ONE MILLION DOLLARS (\$1,000,000) each occurrence and
TWO MILLION DOLLARS (\$2,000,000) per job aggregate.

The policy shall be applicable to all premises and operations. The policy shall include coverage for bodily injury, broad form property damage (including completed operations), personal injury (including coverage for contractual and employee acts), blanket contractual, products, and completed operations. The policy shall include coverage for explosion, collapse, and underground hazards. The policy shall contain a severability of interests provision.

- (c) Comprehensive Automobile Liability insurance with minimum combined single limits for bodily injury and property damage of not less than:

ONE MILLION DOLLARS (\$1,000,000) each occurrence and
ONE MILLION DOLLARS (\$1,000,000) aggregate

with respect to each of Contractor's owned, hired or non-owned vehicles assigned to be used in performance of the Work. The policy shall contain a severability of interests provision.

- (d) For contracts for construction of insurable structures, which are able to be occupied, the Contractor agrees to provide and maintain a Builder's Risk Insurance Policy with minimum limits of not less than the insurable value of the Work to be performed under this Contract at completion, less the value of the materials and equipment insured under Installation Floater Insurance. The policy shall be written in completed value form and shall protect the Contractor, Subcontractor, and the City against risks of damage to buildings, structures, materials and equipment not otherwise covered under Installation Floater Insurance, from the perils of fire and lightning, the perils included in the standard coverage endorsement, and the perils of vandalism and malicious mischief.
- (e) The Contractor agrees to provide and maintain an Installation Floater Insurance Policy with minimum limits of not less than the insurable value of the Work to be performed under this Contract at completion, less the value of the materials and equipment insured under the Builder's Risk Insurance. Equipment such as pumps, engine-generators, compressors,

City of Grand Junction, Colorado
General Contract Conditions

motors, switch-gear, transformers, panelboards, control equipment, and other similar equipment shall be insured under Installation Floater Insurance when the aggregate value of the equipment exceeds \$10,000. The insurable value of the Work shall include the aggregate value of any City-furnished equipment and materials to be erected or installed by the Contractor not otherwise insured under Builder's Risk Insurance. The policy shall protect the Contractor, Subcontractor, and the City from all insurable risks of physical loss or damage to materials and equipment not otherwise covered under Builder's Risk Insurance, while in warehouses or storage areas, during installation, during testing, and after the Work under this Contract is completed. The policy shall be of the "all risks" type, with coverage designed for the circumstances which may occur in the particular Work to be performed under this Contract. The policy shall provide for losses to be payable to the Contractor and the City as their interests may appear. The policy shall contain a provision that in the event of payment for any loss under the coverage provided, the insurance company shall have no rights of recovery against the Contractor or the City.

III. The policies required by paragraphs (a), (b), (c), (d) and (e) above shall be endorsed to include the City and the City's officers and employees as additional insureds. Every policy required above shall be primary insurance, and any insurance carried by the City, its officers, or its employees, or carried by or provided through any insurance pool of the City, shall be excess and not contributory insurance to that provided by Contractor. No additional insured endorsement to any required policy shall contain any exclusion for bodily injury or property damage arising from completed operations. The Contractor shall be solely responsible for any deductible losses under any policy required above.

IV. The Contractor shall provide four (4) copies of the certificate(s) of insurance to the Engineer as evidence that policies providing the required coverage, conditions, and minimum limits are in full force and effect, which certificate(s) shall be reviewed and approved by the City prior to commencement of the Contract. The certificate(s) shall identify this Contract and shall provide that the coverage afforded under the policies shall not be canceled, terminated or materially changed until at least 30 days prior written notice has been given to the City.

V. Failure on the part of the Contractor to procure or maintain policies providing the required coverage, conditions, and minimum limits shall constitute a material breach of this Contract upon which the City may immediately terminate this Contract. At its discretion the City may also procure or renew any such policy or any extended reporting period thereto and may pay any and all premiums in connection therewith. The Contractor shall repay all monies so paid by the City to the City upon demand, or the City may offset the cost of the premiums against any monies due to Contractor from the City.

VI. The City reserves the right to request and receive, at any time(s), a certified copy of any policy and any endorsement thereto.

City of Grand Junction, Colorado
General Contract Conditions

VII. The parties hereto understand and agree that the City is relying on, and does not waive or intend to waive by any provision of this Contract, the monetary limitations or any other rights, immunities, and protection provided by the Colorado Governmental Immunity Act, § 24-10-101 et seq., C.R.S., as from time to time amended, or otherwise available to the City, its officers, or its employees.

18. Contractor's Insurance

The Contractor shall not commence work under this Contract until it has obtained all insurance required by this agreement, and the several provisions hereof, and the City has approved such insurance. The Contractor shall also not allow any Subcontractor to commence work on its Contract until all similar insurance required by the Subcontractor has been so obtained and approved.

19. Indemnification

The Contractor agrees to indemnify and hold harmless the City, its officers, employees, insurers, and self-insurance pool, from and against all liability, claims, and demands, on account of injury, loss, or damage, including without limitation claims arising from bodily injury, personal injury, sickness, disease, death, property loss or damage, or any other loss of any kind whatsoever, which arise out of or are in any manner connected with this Contract, if such injury, loss, or damage is caused in whole or in part by, or is claimed to be caused in whole or in part by, the act, omission, error, professional error, mistake, negligence, or other fault of the Contractor, any Subcontractor of the Contractor, or any officer, employee, representative, or agent of the Contractor or of any Subcontractor of the Contractor, or which arise out of any workers' compensation claim of any employee of the Contractor or of any employee of any Subcontractor of the Contractor. The Contractor agrees to investigate, handle, respond to, and to provide defense for and defend against, any such liability, claims, or demands at the sole expense of the Contractor. The Contractor also agrees to bear all other costs and expenses related thereto, including court costs and attorney fees, whether or not any such liability, claims, or demands alleged are groundless, false, or fraudulent.

V. CONTRACTOR'S RESPONSIBILITIES - SAFETY

20. Safety and Protection

I. The Contractor shall be responsible for initiating, maintaining and supervising all safety precautions and programs in connection with the Work. It shall take all necessary precautions for the safety of, and shall provide the necessary protection to prevent damage, injury or loss to:

- (a) All employees on the Work and other persons who may be affected thereby,
- (b) All Work and all materials or equipment to be incorporated therein whether in storage on or off site, and
- (c) Other property at the site or adjacent thereto, including trees, shrubs, lawns, walks, pavements, roadways, structures and utilities not designated for removal, relocation or replacement in the course of construction.

II. The Contractor shall comply with all applicable laws, ordinances, rules, regulations and orders of any public body having jurisdiction for the safety of persons or property or to protect them from damage, injury or loss. The Contractor shall erect and maintain, as required by the conditions and progress of the work, all necessary safeguards for safety and protection, and in addition, it shall comply with all applicable recommendations of the Manual of Accident Prevention in Construction of the Associated General Contractors of America, Inc. The Contractor shall notify owners of adjacent utilities when prosecution of the Work may affect them. All damage, injury or loss to any property caused, directly or indirectly, in whole or in part, by the Contractor, any Subcontractor or anyone, directly or indirectly, employed by any of them or anyone for whose acts any of them may be liable, shall be remedied by the Contractor.

III. In case of injury to persons or property by reason of failure to erect and maintain necessary barricades, safeguards, and signals, or by reason of any act of negligence of the Contractor, its Subcontractors, agents or employees, during the performance of this Contract, the City may withhold payments due the Contractor so long as shall be reasonably necessary to indemnify the City on account of any such injuries. The City's payments or failure to pay any sum shall not be considered as a waiver of its rights.

IV. The Contractor shall designate a responsible member of its organization at the site whose duty shall be the prevention of accidents. This person shall be the Contractor's superintendent unless otherwise designated in writing by the Contractor to the City.

21. Emergencies

In emergencies affecting the safety of persons or the Work or property at the site or adjacent thereto, the Contractor, without special instruction or authorization from the City, is obligated to act at its discretion, to prevent threatened damage, injury or loss. The Contractor shall give the City prompt written notice of any significant changes in the

City of Grand Junction, Colorado
General Contract Conditions

Work or deviations from the Contract Documents caused thereby, and a Change Order shall thereupon be issued covering the changes and deviations involved. If the Contractor believes that additional Work done by it in an emergency which arose from causes beyond its control entitles it to an increase in the Contract Price or an extension of the Contract Time, it may make a request therefore as provided.

22. Blasting and Other Hazardous Work

The Contractor or Subcontractors shall do no blasting or other hazardous work without written permission issued by the City. Before issuance of such permission, the City may require evidence of adequate liability insurance coverage secured at the Contractor's expense for collapse, explosion, blasting, and damage to underground pipes, wiring, conduits and other structures.

23. Excavations

I. Excavations shall be to the lines and grades as shown on the plans or as modified by the Engineer in the field.

II. The excavation operations shall adhere to all Federal, State, and local safety regulations that are applicable. The inspection of the Work by the City shall not relieve the Contractor from any violations of any safety regulations.

III. The Contractor shall be familiar with and comply with the current rules and regulations governing excavation work as set out by the Industrial Commission of Colorado and OSHA.

IV. All radioactive material (as determined by the City Inspector or the Colorado State Department of Health or Environment) designated to be excavated shall be either replaced in the excavation as part of the back fill or hauled to a designated disposal site as directed by the City. All handling, hauling, and disposal of radioactive materials shall be in accordance with local, State and Federal laws and regulations.

24. Traffic Maintained Over Construction

Where traffic is maintained on a roadway under construction, particular care shall be used to shape and maintain the roadbed so that a safe and reasonably smooth surface is available to the traveling public. Ramps from undisturbed streets into excavated areas shall be maintained for traffic on gradual grades and in no case shall a ramp be steeper than a 10% slope. The Contractor shall make full provision for minimizing inconvenience from dust. Marking and lighting the route shall be in accordance with the Manual on Uniform Traffic Control Devices (MUTCD).

25. Traffic Control, Street Closures and Detours

I. No street, alley, sidewalk, trail or other public way shall be closed, blocked or obstructed without first obtaining permission from the City and from the proper authority having jurisdiction over the affected right of way. All road closures, lane closures and other traffic controls shall be set up and maintained in accordance with an approved traffic control plan (TCP). The Contractor shall provide all traffic controls as needed for the safe movement of vehicular traffic and pedestrians through or around the construction work zone and for the protection and safety of all persons and property in

City of Grand Junction, Colorado
General Contract Conditions

and around the work zone. All traffic control devices used shall be in accordance with the Manual on Uniform Traffic Control Devices (MUTCD) and the approved TCP. All warning signs and barricades shall be constructed and displayed according to standards set forth in the MUTCD.

II. At least two (2) Working Days before preconstruction meeting, the Contractor shall submit to the Engineer a detailed TCP for review. This plan shall consist of a sketch or drawing showing the information outlined below:

- (a) The vicinity, street names and specific area within which the project is going to occur, as well as all curbs, gutters, sidewalks, driveways, traffic lanes, cross streets, etc. in the vicinity of the Work.
- (b) Details of all street, sidewalk and lane closures including proposed detour routes. Include the number of days and hours per day that the closures and detours shall be in effect.
- (c) The type, location and spacing of all barricades, warning signs, detour signs, cones and other traffic control devices.
- (d) The locations and schedules of all flaggers that shall be used.
- (e) The name and phone number of the Contractor's designated Traffic Control Supervisor (TCS) and phone numbers of persons who can be reached after working hours, and on holidays and weekends for traffic control needs.
- (f) Any special notes of information on how the traffic control operation is to be handled.

III. During progress of the Project, if significant adjustments on the TCP are necessary or desirable, the Contractor shall submit pertinent proposed revisions in writing to the City for approval at least 3 Working Days prior to proposed implementation of the changed plan.

IV. In addition to other required notices (such as newsletters), at least 24 hours prior to closing any street or roadway the Contractor shall verbally notify the Project Engineer and the City's Communications Center (dispatch), mail delivery and solid waste pick-up, including those listed (with telephone numbers) in the Special Conditions. The Contractor shall notify those referenced above whenever there is a change in a road closure or detour route. In addition, the Communications Center shall be notified 24 hours in advance of all traffic lane closures.

V. Businesses and residences whose access or parking will be restricted by a road closure or detour shall be notified by the Contractor at least 48 hours in advance. Notification shall be in writing and may included in the contractor's weekly newsletter or other approved method. The Contractor shall furnish all barricades, advance warning signs, flag persons and other traffic control devices required to set up and maintain road

City of Grand Junction, Colorado
General Contract Conditions

closures, detours and lane closures as shown on the TCP or as otherwise directed or approved.

VI. The Contractor should consider subcontracting the traffic control work to a qualified company that provides such services. Should the Contractor decide to rent equipment and do the traffic control work itself, it shall designate a Traffic Control Supervisor (TCS) who shall be responsible for the set up, maintenance and removal of all traffic control devices. This supervisor shall be certified by the American Traffic Safety Services Association (ATSSA). The TCS shall have in possession at all times a copy of the MUTCD or a copy of the ATSSA Guide for Work Area Traffic Control.

VII. In any case, no work shall be done until all advance-warning signs and traffic control devices are in place. The City or the Inspector shall have the authority to require the Contractor to provide additional signs or barricades for those locations it deems to be inadequate.

VIII. At times, it may be necessary for the Contractor to provide flag persons to direct traffic. All flag persons provided by the Contractor shall be certified by the Colorado Department of Transportation or ATSSA and shall be wearing the proper safety attire while performing their duties.

IX. Public sidewalks which are under construction or otherwise obstructed shall be properly barricaded at all times. Temporary walkways or pedestrian detours shall be provided around obstructed sections of sidewalk. The City shall approve all fencing, flagging, barricades, signs and other devices used for sidewalk closures and pedestrian detours. Temporary walkways shall be structurally sound and on uniform grade. Any sidewalks left closed overnight shall be marked with Type A flashing lights mounted on approved barricades.

X. Wherever detours are routed over areas other than established public roadways, it shall be the Contractor's responsibility to secure permission from all affected property owners prior to setting up the detours. Traffic shall not be placed on any detour route until it has been graded and delineated in such a way that it is safe for use by the traveling public. The Contractor shall maintain and provide dust control, as needed on all unpaved detour routes.

26. Maintenance of Access and Services

I. The Contractor's operations shall cause no unnecessary inconvenience. The access rights of the public shall be considered at all times.

II. The Contractor shall cooperate with the various parties involved in delivery of mail, collection of trash and other delivery and pick-up services to maintain existing schedules for these services.

III. The Contractor shall maintain access to all properties at all times unless otherwise approved by the City. The Contractor shall notify residents and property owners at least twenty-four (24) hours prior to temporary closure or relocation of driveway access. Access to driveways in construction areas shall be maintained with a uniform gravel surface unless otherwise approved or directed by the Engineer.

VI. CONTRACTOR'S RESPONSIBILITIES - GENERAL

27. Beginning, Progress and Time of Completion

The City shall issue a written Notice to Proceed. The Contractor shall start the work within ten (10) days of the date of the Notice to Proceed. Thereafter, the Contractor shall prosecute the work at such place or places as the Contract Documents require and shall complete the Work within the time limits set forth in the Contract Documents.

28. Schedules

I. At least two (2) Working Days prior to the pre-construction meeting, the Contractor shall submit to the City for approval a written estimated construction schedule, in Gantt chart format, indicating the relative starting and completion dates of the various stages of the work, including Work to be performed by utility companies, and the submittal dates for shop drawings, materials certifications, samples and other items listed on the Schedule of Submittals. The Contractor's project schedule shall provide sufficient time for reviewing, correcting, resubmitting and rechecking shop drawings. The construction schedule shall be related to the entire project, shall provide for expeditious and practical execution of the Work and shall contain reasonable and appropriate detail, including any applicable milestone dated.

II. Before starting the Work, a pre-construction meeting shall be held to review the Contractor's Project schedule and the utility companies' schedules for any utility relocations that may be required. The Contractor shall coordinate its work with that of the various utility companies and shall revise the construction schedule to accommodate any utility relocations that may be necessary.

III. The Contractor shall keep the Project Schedule up to date at all times and shall promptly notify the City of any delays in Work and/or revisions to the construction schedule.

IV. "Float" or "slack" is defined as the amount of time between the early start date and the late start date, or the early finish date or the late finish date, of any activities on the schedule. Float or slack is not for the exclusive use or benefit of either of the Contractor or the City and may be used to benefit the party that first needs or uses it. Notwithstanding anything else contained herein to the contrary, the Contractor may finish the project prior to the contract completion date but shall not assert any claims to the City for schedule delays which prevent it from completing the Project before that date.

29. Schedule of Values

I. In the case of lump sum bids only, before the Contractor's first request for payment, the Contractor shall submit to the City a schedule of values allocated to the various portions of the Work, prepared in such format and supported by such data to substantiate its accuracy as the City may require. This schedule, if accepted by the City, may be used as the basis for the Contractor's requests for payment.

City of Grand Junction, Colorado
General Contract Conditions

II. Should the City issue a change order that decreases or increases the contract amount, the Contractor shall modify the schedule of values to reflect the amount of the decrease or increase.

30. Examination of Contract Documents and Work

Before undertaking the Work, the Contractor shall carefully study and compare the Contract Documents and check and verify all figures shown thereon and all field measurements. It shall at once report in writing to the City any conflict, error or discrepancy which it may discover. The Contractor assumes full responsibility for having familiarized itself with the nature and extent of the Contract Documents; Federal, State and local laws; Work; locality; and local conditions that may in any manner affect work to be done.

31. Subsurface Conditions

I. The existence and location of subsurface structures and utilities indicated on the Construction Drawings are based on pothole information and/or other data compiled by the City as referenced in the Bid Documents. It is the responsibility of the Contractor to investigate and verify in the field prior to construction the location of any such utilities or underground structures. Subsurface structures and utilities that are not accurately located on the construction drawings shall not constitute subsurface or latent physical conditions at the site differing materially from those indicated (“differing site conditions” or “changed conditions”).

II. The Contractor shall promptly notify the City in writing of any subsurface or latent physical conditions at the site differing materially from those indicated in the Contract Documents. The City shall evaluate the contractor’s information and shall, based on City approved surveys and tests, decide if the change is “material”. If the City finds that the results of such surveys or tests indicate subsurface or latent physical conditions differing materially from those indicated in the Contract Documents, a Change Order shall be issued incorporating the necessary revisions.

III. Downtime. In the event of unforeseen or changed conditions that require all or a portion of the work to be stopped, the Contractor shall immediately notify the Engineer of any downtime for equipment, labor and other costs incurred by the stoppage of work. Whenever possible, the affected equipment and labor shall be reassigned to other work on the project until the changed condition(s) can be addressed by the Engineer. Downtime for equipment, labor and other costs shall be documented in writing by the Contractor and acknowledged in writing by the City’s Construction Inspector at the end of each day. Downtime will not be paid for unless authorized in a Work Change Authorization and/or Change Order issued immediately after work is stopped.

32. Shop Drawings and Submittals

I. The Contractor shall submit to the City all Shop Drawings, material certifications, samples and other submittals listed in the Schedule of Submittals or otherwise required by the City. All submittals shall be reviewed by and stamped with the approval of the Contractor. The data shown on the Shop Drawings shall be complete with respect to dimensions, design criteria, materials of construction and the like to enable the City to review the information as required.

City of Grand Junction, Colorado
General Contract Conditions

II. The Contractor shall submit required Shop Drawings to the City sufficiently in advance of construction to allow ample time for reviewing, correcting, resubmitting and rechecking to avoid any delay in progress of the Work.

III. In addition, the Contractor shall submit to the City for review, with such promptness as to cause no delay in Work, all certifications and samples listed on the "Schedule of Submittals" or as otherwise specified in the Contract Documents or directed by the Engineer. All samples and certifications shall have been reviewed and stamped with the approval of the Contractor, identified clearly as to material, manufacturer, any pertinent catalog numbers and the use for which they are intended.

IV. At the time of each submission, the Contractor shall in writing call the City's attention to any deviations that the Shop Drawing or sample may have from the requirements of the Contract Documents.

V. The City shall review with reasonable promptness, Shop Drawings, material certifications and samples submitted by the Contractor, but its review shall be limited to checking for conformance with the design concept of the project and for compliance with the information given in the Contract Documents. The City's review for compliance of a separate item, as such, shall not indicate review for compliance of the assembly in which the item functions. The Contractor shall make any corrections required by the City and shall return the required number of corrected copies of Shop Drawings and resubmit new samples; until no further revisions and/or samples are required. The Contractor shall direct specific attention in writing or on resubmitted Shop Drawings to revisions other than the corrections called for by the City on previous submissions. The Contractor's stamp of review for compliance on any work drawing or sample constitutes a representation to the City that the Contractor has either determined and verified all quantities, dimensions, field construction criteria, materials, catalog numbers and similar data or it assumes full responsibility for doing so. The stamp of review for compliance also constitutes a representation that the Contractor has reviewed or coordinated each Shop Drawing or sample with the requirements of the Work and the Contract Documents.

VI. No Work requiring a Shop Drawing or sample submission shall be commenced until the City has reviewed each submission for compliance with the Contract Documents. A copy of each reviewed work drawing and sample shall be kept in good order by the Contractor at the site and shall be available to the City.

VII. The City's review of Shop Drawings or samples shall not relieve the Contractor from its responsibility for any deviations from the requirements of the Contract Documents unless the Contractor has in writing called the City's attention to such deviation at the time of submission and the City has given written approval to the specific deviation. Review by the City does not relieve the Contractor from responsibility for errors or omissions in the Shop Drawings or for fully complying with the requirements of the Contract Documents.

33. Tests

I. Contractor shall furnish all tests, including reports on tests, called for in the Contract Documents.

II. All tests and retests, unless otherwise provided, shall be in accordance with the pertinent sections of the latest edition of the standard applicable to the material or devices to be tested.

34. Record Drawings

The Contractor shall keep one record copy of all Construction Drawings and Shop Drawings at the site in good order and annotated to show all changes made during the construction process. These shall be available to the City and shall be delivered to it upon completion of the Project.

35. Supervision and Superintendence

I. The Contractor shall supervise and direct the Work efficiently and with its best skill and attention. It shall be solely responsible for the means, methods, techniques, sequences and procedures of construction. The Contractor shall be responsible to see that the finished Work complies strictly with the Contract Documents, and is also solely responsible for Quality Control.

II. During all construction activities, the Contractor shall have at the job site, as its agent, a competent Superintendent, whose duties shall be coordination and management of construction activities. The superintendent shall be the Contractor's representative at the site and shall have authority to act on behalf of the Contractor. All communications given to the superintendent shall be as binding as if given to the Contractor. The Contractor's Superintendent shall not be replaced without advance written notice to the City.

36. Working Days and Hours

No work shall be done on Saturdays, Sundays or City Holidays without the written consent of the City. No work, other than preparation and clean-up, shall be done outside the hours between 8:00 a.m. and 4:30 p.m. without the written consent of the City. Request for such work shall be made a minimum of forty-eight (48) hours prior to the day or days for which the request is being made. Emergency work may be done without prior consent provided the Contractor notifies the Inspector or Project Engineer prior to beginning the work.

37. Protecting and Relocating Utilities

I. It is the responsibility of the Contractor to provide for the location and protection of all structures and utilities.

II. Contractor shall notify the "Utility Notification Center of Colorado" (1-800-922-1987) in a timely fashion as required by Section 9-1.5-101 *et seq.*, C.R.S. Contractor shall request written record of any information from all owners or operators, including the City, of underground facilities (as defined in the above statute) regarding the location of the specific underground facilities. Contractor shall comply with all requirements of the above as it pertains to the "excavator." City shall not be responsible for the accuracy or

City of Grand Junction, Colorado
General Contract Conditions

completeness of any information provided by third-party owners or operators of underground facilities, including the marking thereof.

As stated in § 9-1.5-101, once the underground facilities have been properly marked, it is the duty of the excavator to maintain adequate documentation, such as photographs, videos or sketches, so that the facilities can be accurately located and identified throughout the excavation period.

III. The approximate locations of underground facilities which are owned or operated by the City are shown on the Plans. The City shall, as required by the statute and/or local ordinance, mark the location of all such facilities. The City does not own or locate sewer and/or water service lines. Unless the exact location of City owned underground utilities is shown on the plans, as indicated by reference to horizontal and vertical datum, then the Contract price shall include, and the Contractor shall have full responsibility for determining the exact location and depth of such underground facilities by potholing, handwork or such other means as may be necessary to determine the precise location without damaging such underground facilities, including water and sewer service lines. The Contractor shall incorporate the precise location of such underground facilities, including sewer and water service lines, into the record drawings.

IV. The cost of all of the following shall be included in the Work and Contractor shall have full responsibility for:

- (a) Reviewing and checking all information and data provided by all owners or operators of underground facilities;
- (b) Determining the horizontal and vertical location of all underground facilities shown or indicated in the Contract Documents;
- (c) Coordination of the Work with the owners and operators of all underground facilities during construction; and
- (d) The safety and protection of all such underground facilities and repairing any damage thereto resulting from the Work.

V. If any underground facility is uncovered or revealed at or contiguous to the site which was not shown or indicated in the Contract Documents or by reason of information supplied pursuant to Section 9-1.5-101 *et seq.*, C.R.S., Contractor shall, promptly after becoming aware thereof and before further disturbing conditions affected thereby or performing any Work in conjunction therewith (except in emergency situations) identify the owner of such underground facility and give written notice to that owner, the "Utility Notification Center of Colorado," and the City. Contractor shall incorporate the location of all such underground facilities into the record drawings. The City shall promptly review the underground facility and determine the extent, if any, to which a change is required in the Contract Documents to reflect and document the consequences of the existence of the underground facility. During such time, Contractor shall be responsible for the safety and protection of such underground facility. The Contractor may request an increase in Contract Price or an extension of Contract Time, or both, by submitting a Request for Adjustment form. The Request for Adjustment shall describe in detail the

City of Grand Junction, Colorado
General Contract Conditions

extent of material changes to the Work resulting from an underground facility(ies) that is not shown or indicated in the Contract Documents and that the Contractor did not know of and could not reasonably have been expected to be aware of or to have anticipated. If City and Contractor are unable to agree on an adjustment in amount of the Contract Price or length of time allowed under the Contract Time then the Contractor may make a claim as provided in the Contract Documents.

VI. In the event of a break in an existing water main, gas main, sewer or underground cable, the Contractor shall immediately notify the responsible official of the organization operating the utility interrupted and shall lend all possible assistance in restoring services and making repairs.

VII. The Contractor shall bear the entire expense of repairing or replacing any utilities or structures disturbed or damaged during construction, except those not properly located by the owner, pursuant to 9-1.5-101 et seq., C.R.S.; except that the City may pay the Contractor to replace old or defective water and/or sewer service lines as the Project Engineer determines on a case-by-case basis.

VIII. Contractor must reconnect all active water and sewer service lines encountered during the Work, and shall install new taps and service lines to the property line of vacant property as shown on the drawings or as directed by the City. The Contractor shall determine which taps are active, in cooperation with the City, and shall record the location of all new service lines, taps and other connections on the record drawings.

IX. Unless otherwise specified in the Contract Documents, all utility relocations shall be the responsibility of the affected utility companies. The Contractor shall be responsible for coordinating his work and schedule with those of each utility company so that any utility relocation does not unnecessarily delay or interfere with other work on the Project.

38. Labor, Materials and Equipment

I. The Contractor shall provide competent, suitably qualified personnel to lay out the Work and perform construction as required by the Contract Documents. It shall at all times maintain good discipline and order at the site.

II. The Contractor shall furnish all materials, equipment, labor, transportation, construction equipment and machinery, tools, appliances, fuel, power, light, heat, telephone, water, and sanitary facilities and all other facilities and incidentals necessary for the execution, testing, operation and completion of the Work.

III. All installed materials and equipment shall be new, except as otherwise provided in the Contract Documents. If required by the City, the Contractor shall furnish satisfactory evidence as to the kind and quality of materials and equipment.

IV. All materials and equipment shall be applied, installed, connected, erected, used, cleaned and conditioned in accordance with the instructions of the applicable manufacturer, fabricator or processors, except as otherwise provided in the Contract Documents.

39. Character of Workers

I. The Contractor shall at all times employ sufficient labor and equipment for prosecuting the several classes of Work to full completion in the manner and time required by these specifications.

II. All workers shall have sufficient skill and experience to perform properly the Work assigned to them. Workers engaged in special Work or skilled Work shall have sufficient experience in such Work and in the operation of the equipment required to perform all Work properly and satisfactorily.

III. Any person employed by the Contractor or by any Subcontractor who, as determined by the City, does not perform his Work in a proper and skillful manner or is intemperate or disorderly shall, at the written request of the City, be removed forthwith by the Contractor or Subcontractor employing such person, and shall not be employed again in any portion of the Work without the approval of the City.

IV. Should the Contractor fail to remove such person or persons as required above or fail to furnish suitable and sufficient personnel for the proper prosecution of the Work, the City may suspend the Work by written notice until such orders are complied with.

40. Construction Equipment

I. All equipment which is proposed to be used on the Project shall be of sufficient size and in such mechanical condition as to meet requirements of the Work and to produce a satisfactory quality of work. Equipment used on any portion of the project shall be such that no injury to the roadway, adjacent property, or other facilities shall result from its use. Any damage caused by the equipment shall be repaired or replaced at the Contractor's expense.

II. When the methods and equipment to be used by the Contractor in accomplishing the construction are not prescribed in the Contract, the Contractor is free to use any methods or equipment that it demonstrates, to the satisfaction of the City, shall accomplish the Work in conformity with the requirements of the Contract.

41. Methods of Operation

I. The Contractor shall give to the City full information in advance as to its plans for carrying out any part of the Work. If at any time before the beginning or during the progress of the Work, any part of the Contractor's plant or equipment or any of its methods of executing the Work appear to the City to be unsafe, inefficient, or inadequate to insure the required quality, rate of progress or safety of the workers, the Project Engineer and/or the City Inspector may notify the Contractor regarding unsafe, inadequate and/or inefficient means and methods but only the Engineering Manager or the City Utility Engineer may order the Work to be suspended until the unsafe, inadequate and/or inefficient issues are addressed; the City shall not dictate the means and methods for the Contractor, it may order the Contractor to increase or improve the Contractor's facilities or methods. The Contractor shall promptly comply with such orders. Neither compliance with such orders nor failure of the City to issue such orders shall relieve the Contractor from its obligation to secure the degree of safety, the quality of work, and the rate of progress required by this Contract. The approval by the City of

City of Grand Junction, Colorado
General Contract Conditions

any plan or method of work proposed by the Contractor shall not be considered as an assumption by the City, or any officer, agent or employee thereof, of a risk or liability, and the Contractor shall have no claim under this Contract on account of the failure or inefficiency of any plan or method so approved. Such approval shall be considered and shall mean that the City has no objection to the Contractor's use or adoption, at his own risk and responsibility, of the plan or method so proposed by the Contractor.

II. Any plan or method of work suggested by the City, or any representative of the City, to the Contractor, if adopted or followed by the Contractor in whole or in part, shall be used at the risk and responsibility of the Contractor and the City and the City shall assume no responsibility therefore.

III. Where equipment, materials or articles are referred to in the Specifications as "equal to" any particular standard or product, the City shall decide the questions of equality. The Contractor shall furnish to the City for its approval the name of the manufacturer of the equipment or materials which it contemplates installing, together with their performance history and other pertinent information. When required by the Specifications, or when called for by the City, the Contractor shall furnish the City for its approval full information concerning the equipment, materials or articles which it contemplates incorporating in the Work. Samples of materials shall be submitted for approval when so requested. Equipment, materials, and articles installed or used without such approval shall be at the risk of subsequent rejection.

42. Cooperation of Contractor

I. General: The Contractor shall give the Work the constant attention necessary to facilitate the progress thereof and shall cooperate with the City and with other contractors in every way possible.

II. Discrepancies: If the Contractor, as the Work progresses, finds any discrepancies between the Drawings and physical conditions or any errors in the Drawings or survey control as given by stakes or instructions, the Contractor shall have the duty to inform the City in writing and the City shall promptly correct the same. Any Work done after such discovery, until authorized, shall be done at the Contractor's risk. The Contractor may request an increase in Contract Price or an extension of Contract Time, or both, by submitting a Request for Adjustment form. The Request for Adjustment shall describe in detail the extent of material changes to the Work resulting from discrepancy(ies) in the drawings. If City and Contractor are unable to agree on an adjustment in amount of the Contract Price or length of time allowed under Contract Time then the Contractor may make a claim as provided in the Contract Documents.

III. Contractor's Responsibility for Work: Until the Work is accepted by the City as evidenced in writing, the Contractor shall have the charge and care thereof and shall take every necessary precaution against injury or damage to any part thereof by the action of the elements or from any other cause, whether arising from the execution or from the non-execution of the Work. The Contractor shall rebuild, repair, restore, and make good all injuries or damages to any portion of the Work occasioned by any of the above causes before its completion and acceptance and shall bear the expense thereof. In case of suspension of Work from any cause whatever, the Contractor shall be

City of Grand Junction, Colorado
General Contract Conditions

responsible for all materials and shall properly store them if necessary, at a location approved by the City.

43. Neglected or Defective Work

I. If the Contractor should neglect to prosecute the Work in accordance with the Contract Documents, including any requirements of the progress schedule, the City, after ten (10) days written notice to the Contractor, may without prejudice to any other remedy it may have, make good such deficiencies. The cost thereof shall be charged against the Contractor. The City shall have authority to disapprove or reject Defective Work. If required by the City prior to approval of final payment, the Contractor shall promptly, without cost to the City and as specified by the City, either correct any Defective Work, whether or not fabricated, installed or completed, or if Work has been rejected by the City, remove it from the site and replace it with non-Defective Work. If the Contractor does not correct such Defective Work or remove and replace such rejected work within a reasonable time, all as specified in a written notice from the City, the City may have the deficiency corrected or the rejected Work removed and replaced. All direct or indirect costs of such correction or removal and replacement shall be at the Contractor's expense, and an appropriate deductive Change Order shall be issued. The Contractor shall also bear the expenses of making good all Work of others destroyed or damaged by its correction, removal or replacement of its Defective Work.

II. If, instead of requiring correction or removal and replacement of Defective Work, the City prefers to accept the Work, it may do so. In such case, if acceptance occurs prior to approval of final payment, a Change Order shall be issued incorporating the necessary revisions in the Contract Documents, including appropriate reduction in the Contract price. If the acceptance occurs after approval of final payment, the Contractor shall pay an appropriate amount to the City.

44. Work by Others

I. The City reserves the right at any time to contract for and perform other or additional work on or near the Work covered by the Contract.

II. The Contractor shall make allowances in the Bid for scheduling and pursuing Work in such manner as shall facilitate coordination with other possible concurrent construction operations.

III. When separate Contracts are let within the limits of any one project, each Contractor shall conduct Work so as not to interfere with or hinder the progress of completion of the Work being performed by other contractors. Contractors working on the same project shall cooperate with each other as directed.

IV. The Contractor shall arrange Work and shall place and dispose of the materials being used so as not to interfere with the operations of other Contractors within the limits of the same project. It shall join its Work with that of the others in an acceptable manner and shall perform the Work in proper sequence to that of the others.

V. The Contractor shall cooperate with all other contractors for and workers of the City, including construction forces of the Public Works and Planning Department, and other public utility company forces, who may be performing other Work at or in the vicinity of

City of Grand Junction, Colorado
General Contract Conditions

the Work hereby contracted. Any conflict which may arise between the Contractor and such other contractors or workers in regard to their Work shall be adjusted and determined by the City. If the Work of the Contractor is delayed because of any acts or omissions of such other contractors or workers, the Contractor shall have no claim against the City on that account other than for an extension of time. When Work under two or more contracts is being executed at one time in such manner that Work on one contract may interfere with that on another, the City shall decide which contractor shall cease Work and which shall continue or whether the Work on both contracts shall progress at the same time and in what manner. The territory of one contract often is the necessary or convenient means of access for transportation of movement of men, materials or appliances required for the execution of another contract. Such privilege of access or any other reasonable privilege may be granted by the City to the extent, manner and at the time which may be reasonably necessary.

VI. Each contractor involved shall release the City and its employees and agents from any and all damages or claims that may arise because of inconvenience, delay or loss experienced by the Contractor because of the presence or actions of third parties.

45. Payment for Labor and Materials

The Contractor agrees that it shall pay promptly for Work, services and labor of every kind and for teamsters, teams, trucks, Subcontractors; equipment employed on the Work; for all materials that it may use in the Work and for all labor and material incidental to the completion of the Work. If evidence is produced before final settlement that the Contractor has at any time failed to pay for work or services of any kind for laborers and/or Subcontractors, teamsters, trucks, or equipment employed on this Work or failed to pay for the materials used therein or if the City has reason to suspect that such payments have not been made, the City may withhold from payments due sufficient moneys to cover these items. Upon satisfactory evidence to the City as to the amount due for such labor and materials used therein, the City may settle and pay for them, and charge the amounts to the Contractor, or deduct them from any balance or balances due the Contractor. The production of receipts showing payment for labor and materials and payment of subcontractors may be required by the City before any partial or final payment is allowed or made.

46. Public Relations and Notifications

I. The Contractor shall carry on the Work in such manner as to cause as little inconvenience as possible to the public, particularly to occupants of property along the project, as is consistent with good workmanship. The Contractor shall notify occupants at least twenty-four (24) hours in advance of proposed Work that may block entrances or otherwise cause undue difficulty to occupants of property affected and shall restore such entrances to usable condition as soon as possible. The Contractor, Subcontractors and employees shall at all times be courteous to the public while engaged upon this Work.

II. The Contractor shall notify all business managers and residents affected by the interruption of utilities and other services caused by its operations. Such notice shall be given at least forty-eight (48) hours prior to the interruption of service. Notice shall be given for the interruption of domestic water, irrigation water, sewer, trash pickup, mail delivery and changes in access to property. Prior to interruption of domestic water

City of Grand Junction, Colorado
General Contract Conditions

service, a second notice shall be given no less than one hour and no more than four hours prior to discontinuation of service.

III. Notifications may be verbal or in written form. If the business manager or resident cannot be located, the Contractor shall use door hanger notice cards furnished by the City for interruption of domestic water service. Water services shall not be discontinued for more than two (2) consecutive hours without special written permission from the City. Door hangers shall not be attached to or placed in mailboxes or vehicles.

IV. Contractor is to replace all active taps encountered, and to install taps at all vacant parcels as shown on the drawings or directed by the City. It is Contractor's responsibility to determine which taps are active and which are not and to coordinate with the City in the location of taps to vacant parcels.

V. Where trees, hedges, shrubs, or other ornamental plantings or structures within the construction limits are not designated to be protected or saved, the Contractor shall notify the owner of the property fronting the plantings or structures in question, not less than ten (10) Calendar Days prior to their removal. This notification shall include allowing the property owner the option to transplant the plantings or relocate structures fronting his property onto his property instead of having the Contractor remove them. The Contractor shall bid the project based on assuming responsibility for all removals. This notification requirement is intended as a positive public relations action.

VI. All notifications described and required in this section are considered as incidental to the Work and shall not be measured or paid for separately.

47. Protection and Restoration of Property and Landscape

I. The Contractor shall be responsible for the preservation of all public and private property and shall protect from disturbance or damage all land monuments, survey monuments and property markers not designated for removal. Prior to disturbance or removal of any survey monuments or property marker, the Contractor shall first notify the property owner or agency having jurisdiction over the marker and shall reference the point in accordance with Section 629 of the Standard Specifications for Road and Bridge Construction.

II. The Contractor shall be responsible for all damage or injury to property of any character during the prosecution of the Work resulting from any act, omission, neglect, or misconduct in its manner of method of executing the Work, or any time due to Defective Work or materials, and said responsibility shall not be released until the project has been completed and accepted or until any applicable warranty periods have expired, whichever is later.

III. When or where any direct or indirect damage or injury is done to public or private property by or on account of any act, omission, neglect, or misconduct by the Contractor in the execution of the Work, or in consequence of the non-execution thereof by the Contractor, the Contractor shall restore, at its own expense, such property to a condition similar or equal to that existing before such damage or injury was done, by repairing, rebuilding, or otherwise restoring as may be directed, or it shall otherwise make good such damage or injury in an acceptable manner.

City of Grand Junction, Colorado
General Contract Conditions

IV. The Contractor shall assume full responsibility and expense for the protection of all public and private property, structures, water mains, sewers, utilities, etc., both above and below ground, at or near the site or sites of the Work being performed under the Contract, or which are in any manner affected by the prosecution of the Work or the transportation of men and materials in connection therewith. The Contractor shall give reasonable written notice in advance to the Department of the City having charge of any property or utilities owned by the City and to other owner or owners of public and private property or utilities when they shall be affected by the Work to be performed under the Contract. The Contractor shall make all necessary arrangements with such Department, Departments, owner or owners for the removal and replacement or protection of such property or utilities.

V. Track equipment used on paved areas shall be fitted with pavement tracks, or other means shall be provided to protect the pavement. The City prior to use shall approve such equipment.

48. Cleaning Up

I. The Contractor shall be responsible for clean up and containment operations on a daily basis to prevent rubbish, debris, or other materials from blowing or spreading offsite. The Contractor shall remove and clean up all rubbish, debris, excess material, temporary structures, tools and equipment from streets, alleys, parkways, project areas and adjacent property that may have been used, littered or worked on by the Contractor in connection with the project promptly as each section or portion is completed and ready for use, leaving the same in a neat and presentable condition. Payment of monthly or partial estimates may be withheld until this has been done to the satisfaction of the City. Final acceptance and payment for the entire project shall not be made until the clean-up has been fully completed. In the event of failure to do so on the part of the Contractor, the City at the expense of the Contractor shall complete the clean-up.

II. The Contractor shall conduct its operations so as not to have equipment tracking excessive amounts of mud and earth onto the adjacent public streets. Upon notification by the City or its representative, the Contractor may be required to clean from public streets mud and/or earth tracked by its equipment or that of subcontractors or material suppliers to the project. This authority shall be exercised only where the amount of tracked mud and/or earth is considered excessive in the judgment of the City. A certain amount of trackout from the project area is reasonably expected to occur. The extent of this condition is directed only at "excessive" trackout which would constitute a nuisance or hazard to motorists on public streets.

49. Assignment or Subletting

I. The Contractor shall not assign or subcontract the whole or any part of the Contract without the prior written consent of the City. In no case shall the Contractor be permitted to subcontract more than seventy-five percent (75%) of the total amount of the Contract, unless otherwise specified in the Special Conditions.

II. The Contractor shall not employ any Subcontractor against whom the City may have reasonable objection, nor shall the Contractor be required to employ any Subcontractor against whom the Contractor has reasonable objection. The Contractor shall not make

City of Grand Junction, Colorado
General Contract Conditions

any substitution for any Subcontractor who has been accepted by the City, unless the City determines that there is good cause for doing so. All requests for Subcontractor substitutions shall be made to the City in writing.

III. The Contractor shall be fully responsible for all acts and omissions of its Subcontractors and of persons directly or indirectly employed by them and of persons for whose acts any of them may be liable to the same extent that it is responsible for the acts and omissions of persons directly employed by it. Nothing in the Contract Documents shall create any contractual relationship between any Subcontractor and the City or any obligation on the part of the City to pay or to see to the payment of any moneys due any Subcontractor, except as may otherwise be required by law. The City shall furnish to any Subcontractor, to the extent practicable, evidence of amounts paid to the Contractor on account of specific work done.

IV. The divisions and sections of the Specifications and the identifications of any Drawings shall not control the Contractor in dividing the Work among Subcontractors or delineating the Work to be performed by any specific trade.

50. Excess Material

I. Unless otherwise specified or directed by the City, all excess excavated material, including soil, gravel, asphalt pavement and miscellaneous concrete, shall become the property of the Contractor and shall be hauled to a location secured by the Contractor and approved by the City.

II. Any radioactive material (as determined by the Colorado Department of Health or Environment) to be excavated and disposed of, shall be hauled by the Contractor to a site designated by the Colorado Department of Health or Environment. The Contractor shall make all arrangements for removing and disposing of this material. This work shall be paid for in accordance with the Standard Specifications for Road and Bridge Construction.

51. Stockpiling Materials and Equipment

When approved by the City, the Contractor may stockpile and store materials and equipment within public right-of-way so long as such storage does not create an unsafe condition or obstruct any walkway or traffic lane. All materials and equipment left at the end of the day shall be moved as far as possible from the traveled roadway and intersections. If the Contractor is allowed to stockpile or store equipment and materials on the shoulder of the roadway, such obstruction shall be barricaded or marked in accordance with the MUTCD. The Contractor shall be responsible for obtaining, in writing, permission to use private property for storage of materials and equipment. Copies of these agreements shall be submitted to the City. The Contractor shall bear the risk of damage and/or loss to stored equipment or materials.

52. Operations, Staging and Use of Private Utilities

I. All operations of the Contractor (including storage of materials, supplies and equipment) shall be confined to areas authorized by the City. The Contractor shall be liable for any and all damages caused by it to such premises. The Contractor is solely responsible for acquisition and payment for any other staging area to be used. The

City of Grand Junction, Colorado
General Contract Conditions

Contractor shall not connect to or use any private water or electric services or other facilities on private property without the written permission of the property owner or tenant.

II. The Contractor shall hold and save the City free and harmless from liability of any nature or kind arising from any use, trespass or damage occasioned by its operations on the premises of third persons.

III. The Contractor shall be wholly responsible for the care, compliance with the law, and storage of materials, supplies or equipment delivered on the worksite or purchased for use thereon. Stored materials, supplies or equipment shall be carefully and continuously protected from damage or deterioration and so located as to facilitate inspection by the City. The responsibility for the care and storage of materials, supplies or equipment shall be with the Contractor whether such materials, supplies or equipment are furnished by the Contractor or by the City. Storage of materials, supplies or equipment shall not unduly interfere with the progress of the Contractor's work or the work of any other contractor.

53. Survey Reference Points

I. All Work done under this Contract shall be done to the lines, grades and elevations shown on the plans or established by the City.

II. Any Work done without being properly located by reference to established monuments, benchmarks, or other basic reference points which have been located, established or checked by the City may be ordered, removed and replaced at the Contractor's cost and expense.

III. The Contractor shall be held responsible for the proper preservation of all monument, benchmarks, reference points, and stakes. If any of them are disturbed or destroyed by the Contractor, its employees and/or subcontractors, any City costs incurred in replacing all such marks shall be charged against the Contractor who shall not be granted an extension of time or allowed any damages for delays resulting from such disturbance or destruction.

54. Construction Surveying and "As-Built" Drawings

I. By contract with its surveyor, the Contractor shall be responsible for all construction surveying, calculating, layout and staking necessary for construction of all elements of the project. All construction surveying and preparation of As-Built drawings shall be in accordance with Section 625 of the City's Standard Specifications for Road and Bridge Construction.

II. As the work progresses and throughout the duration of the Project, the Contractor and/or its Surveyor shall prepare and maintain a current a set of As-Built Construction Drawings showing all changes and deviations from the drawings that were made in the constructed improvements. This shall include all changes in horizontal location and vertical elevation of all constructed improvements, both underground and on the surface. The As-Built drawings shall be available to the Construction Inspector and the City at the job site during working hours.

55. Weekly Meetings

Weekly or other regularly scheduled or periodic meetings, if required by the City, shall typically be held between the City, Contractor and other affected agencies at a standard time and place, established during the preconstruction meeting, or as otherwise scheduled by the City. These meetings shall be used to discuss scheduling and critical project issues.

56. Newsletter

I. When specified in the Special Conditions, the Contractor shall be required to prepare a periodic newsletter which shall include a brief description of the following:

- (a) Work completed during the previous period;
- (b) Work scheduled for the next period;
- (c) Information about any road closures, detours and other activities that may cause delays or inconvenience to the neighborhood or the general public;
- (d) Scheduled or planned interruption or changes in any utility services, trash pickup, mail delivery or other services; and
- (e) Project Schedule changes or other information that may be useful or of interest.

II. The City shall furnish the Contractor with a mailing list of property owners, news media and individuals to whom the newsletter shall be sent. Composition, printing and delivery of the newsletter shall be the responsibility of the Contractor. Each newsletter shall be type-written and printed on the Contractor's letterhead and contain the names and telephone numbers of the Contractor's and the City's contact people. The first newsletter shall be prepared and mailed out at least one week before construction begins. The number and frequency of subsequent newsletters shall be as specified in the Special Conditions.

57. Trash Collection

Prior to beginning any work which interferes with the collection of trash, the Contractor shall notify the City's Solid Waste Supervisor, at 244-1570 and all other trash service providers to coordinate trash collection schedules and trash pickup locations. The Contractor shall notify the affected trash service providers when normal collection service may be restored.

58. Mail Delivery Service

Prior to beginning any work which will interfere with the delivery of mail, the Contractor shall notify the U.S. Postal Service to coordinate mailbox relocations and mail delivery services.

VII. CITY'S RESPONSIBILITIES

59. Availability of Lands

I. The City shall furnish, as indicated in the Contract Documents and not later than the date when needed by the Contractor, the lands upon which the Work is to be done, rights-of-way for access thereto, and such other lands which are designated or required for construction of the project. Easements required for permanent structures or permanent changes in existing facilities shall be obtained and paid for by the City, unless otherwise specified in the Contract Documents. If the Contractor believes that any delay in the City's furnishing these lands or easements entitles it to an extension of the Contract Time, it may make a request therefor. The Contractor shall provide for all additional lands and access thereto that may be required for temporary construction facilities or storage of materials and equipment.

II. Nothing herein contained and nothing marked on the drawings shall be interpreted as giving the Contractor exclusive occupancy of the territory provided by the City. The City and its employees for any purpose, and other contractors of the City for any purpose required by their respective contracts, may enter upon or occupy portions of the land furnished by the City. When the territory of one Contract is the necessary or convenient means of access for the execution of another contract, such privileges of access or any other reasonable privilege shall be granted by the Contractor to the extent, amount, in the manner, and at time necessary. No such joint occupancy or use of the territory shall be made the basis of any claim for delay or damages.

60. Authority of the City Manager

The City Manager is the final representative of the City in all matters concerning Contracts and has the authority to execute and bind the City for same.

61. Authority of the Engineering Manager and Project Engineer

I. The Engineering Manager shall have the authority to order suspension of the Work, to extend the time for completion, to order Additional Work, modifications and alterations, and with the City Manager to terminate the Contract as elsewhere herein provided. The Engineering Manager shall make the final decision on all questions as to acceptable technical fulfillment of the Contract, all disputes from the Contractor as to performance or fulfillment of the Contract, and all questions as to compensation for Work, including Extra Work performed. The Engineering Manager shall have executive authority to make effective all decisions and to direct the Contractor or Contractors to carry out all orders promptly.

II. The Engineering Manager may assume exclusive control of the place of performance of this Contract or any part thereof whenever such place of performance shall be located in public rights-of-way, easements or upon property belonging to the City. Moreover, the City reserves the right at any time to let other contracts in the area or areas covered by the Work included in the Contract; and the City, its other independent Contractors, its agents and employees may enter upon or occupy any part or all the property owned by the City to the extent ordered by the City. The Engineering Manager, under the authority and direction of the Manager, is to exercise general supervision for the City of all Work covered by the Contract. He shall decide any and all questions which may arise as to

City of Grand Junction, Colorado
General Contract Conditions

the quality and acceptability of the materials furnished, the Work performed, the manner of performance and the rate of progress of the Work, shall decide all questions that may arise as to the interpretations of the Contract Documents and Specifications, and shall authorize Extra Work. He shall appoint such inspector or inspectors as he deems them necessary for the inspections of materials and Work done under the Contract in order that the Work may be carried out and completed to Final Completion, as such term is defined herein.

III. The Project Engineer shall oversee the design and construction of the project. He has the authority to administer the construction contract and authorize any changes in the contract which do not exceed the contract price. Any question as to the authority of the Project Engineer shall be resolved with the Engineering Manager.

62. Limitations on Engineer's Responsibilities

I. A decision made by the City in good faith, either to exercise or not exercise its authority shall not give rise to any duty or responsibility of the City to the Contractor, any Subcontractor, any of their agents or employees or any other person performing any of the Work.

II. The Engineer shall not be responsible for the construction means, methods, techniques, sequences or procedures, or the safety precautions and programs incident thereto, and he shall not be responsible for the Contractor's failure to perform the Work in accordance with the Contract Documents.

III. The Engineer shall not be responsible for the acts or omissions of the Contractor, or any Subcontractors, or any of his or their agents or employees, or any other persons performing any of the Work.

63. Clarifications and Interpretations

The City shall issue with reasonable promptness such written clarifications or interpretations of the Contract Documents (in the form of Drawings or otherwise) as it may determine necessary, which shall be consistent with or reasonably inferable from the overall intent of the Contract Documents. If the Contractor believes that a written clarification and interpretation entitles it to an increase in the Contract price, the Contractor may make a claim request therefor as provided.

64. Orders To Contractor's Agent

When the Contractor is not present on any part of the Work where it may be desired to give directions, orders may be given by the City or its representative to, and shall be received and obeyed by, the Superintendent or foreman who may have charge of the particular part of the Work in reference to which such orders are given.

65. Authority and Duties of Inspectors

Inspectors may be assigned by the City to inspect materials used and Work done under the Contract. Such inspections may extend to all or any part of the Work and to the preparation or manufacture of the materials to be used. The inspectors shall not be authorized to revoke, alter, enlarge or relax the provisions of the Contract Documents, nor to delay the fulfillment of the Contract by failure to inspect materials and Work with

City of Grand Junction, Colorado
General Contract Conditions

reasonable promptness. An inspector is assigned on the Work to keep the City informed as to the progress of the Work and the manner in which it is being done. The Inspector shall also call the attention of the Contractor to any deviations from the Contract Documents and not to act as a foreman for the Contractor. The Inspector shall have authority to reject defective materials and Work, subject to the final decision of the City.

66. Inspection of Work

I. The Inspector is authorized to approve or reject any portion of the Work and may require additional testing as provided by the Contract Documents, but cannot issue instructions contrary to the Contract Documents. Changes to the Contract Documents can only be made by the Engineer and must in writing. No Work shall be covered or backfilled without first having given reasonable advance notice to the City to allow the Inspector to view the Work and circumstances; if despite reasonable advance notice, the City does not timely inspect the Work, the Contractor may cover or backfill the Work but remains responsible for ensuring that the Work complies with the Contract Documents.

II. The Contractor shall regard and obey the directions and instructions of the City and Inspectors when the same are consistent with the Contract Documents; provided, however, that should the Contractor object to any order given by an Inspector, the Contractor may make an appeal to the City, pursuant to Article XV regarding Disputes.

III. Observations, inspections, and tests by the City, Inspector, or others are for the express purpose of providing quality assurance for the sole benefit of the City. Such activities shall not relieve the Contractor from its quality control obligations or from its obligations to perform the Work strictly in accordance with the requirements of the Contract Documents.

IV. Inspectors are placed on the Work to keep the City informed as to the progress of the Work and the manner in which it is being done; to keep records; act as liaison between the Contractor and the City; and to call the attention of the Contractor to any deviations from the Contract Documents. Failure of the Inspector to call the attention of the Contractor to faulty work or deviations from the Contract Documents shall not constitute acceptance of said Work.

V. Since one of the Inspector's primary interests is to see that the work on the Project progresses expediently and in a good and workmanlike manner, the Inspector may at various times offer suggestions to the Contractor, which the Contractor may or may not follow, at its discretion. Such suggestions are never to be considered anything but suggestions and involve no assumption of responsibility, financial or otherwise, by either the Inspector or the City.

VI. The Inspector or the City shall not construe any personal assistance which an Inspector may give the Contractor as the basis of any assumption of responsibility in any manner, financial or otherwise.

VII. The Inspector is not and does not purport to be a safety engineer and is not engaged in that capacity by the City and shall have neither authority nor the

City of Grand Junction, Colorado
General Contract Conditions

responsibility to enforce construction safety laws, rules, regulations, procedures for the safety of persons on or about the construction site.

VIII. The presence or absence of an Inspector on the job shall be at the sole discretion of the City and such presence or absence of an Inspector shall not relieve the Contractor of its responsibility to obtain the construction results specified in the Contract Documents.

IX. The Inspector shall not be authorized to approve or accept any portion of the work or to issue instructions contrary to the Contract Documents. Such approvals, acceptance or instructions, when given, must be in writing and signed by the Engineer. The Inspector shall have authority to reject defective materials, subject to the final decision of the Engineer, however, the failure of the Inspector to reject defective materials or any other work involving deviations from the Contract Documents shall not constitute acceptance of such work.

X. Nothing in this subsection shall in any way be construed as to require or to place responsibility for the method, manner or supervision of the performance of the Work under this Contract upon the Inspector or the City. Such responsibility rests solely with the Contractor.

XI. All material and workmanship (if not otherwise designated by the Specifications) shall be subject to inspection, during manufacture and/or construction and at any and all places where such manufacture and/or construction is carried on. The City shall have the right to reject defective material and workmanship or require its correction.

XII. The Contractor shall furnish promptly without additional charge all reasonable facilities, labor, equipment and materials necessary for quality assurance tests that may be reasonably required by the Inspector, including re-testing of failed tests. All inspections and tests by the City shall be performed in such a manner as not to unnecessarily delay the Work. The type, quantity and minimum or acceptable range of results of performance tests shall be as described in the Specifications.

XIII. Should it be considered necessary or advisable by the City at any time before Final Completion of the entire Work to make examinations of work already completed, by removing any part or parts of the same, the Contractor shall upon request promptly furnish all necessary facilities, labor, and material. If any such work is found to be defective, due to the fault of the Contractor or its Subcontractors, it shall pay all the expenses of such examination and of satisfactory reconstruction. If, however, such work is found to meet the requirements of the Contract and the City's decision to remove the work was improper, the "Actual Cost" as defined in Section 71, Method of Payment, necessarily involved in the removal, examination and replacement of the work shall be allowed the Contractor (who shall pay any Subcontractors from money received) and if completion of the Work has been delayed thereby, a suitable extension of time on account of the Additional Work involved shall be allowed if the Contractor makes a written request as provided in the Contract Documents.

XIV. The City must approve the source of supply of each of the materials before delivery is started. Only materials conforming to the requirements of these Specifications and

City of Grand Junction, Colorado
General Contract Conditions

approved by the City shall be used in the Work. All materials proposed to be used may be tested at any time during their preparation and use. If, after trial it is found that sources of supply which have been approved do not furnish a uniform product, or if the product from any source proves unacceptable at any time, the Contractor shall furnish approved materials from another approved source. No material which, after approval, has in any way become unfit for use shall be used in the Work. The Contractor shall notify the City a sufficient time in advance of the manufacture or production of materials to be supplied by it under this Contract in order that the City may arrange for mill and factory inspection and testing of same. No materials shipped by the Contractor from the factory prior to having satisfactorily passed such testing and inspection by the City's Representative, or prior to the receipt of written notice from said Representative that such testing and inspection shall not be required, shall be incorporated in the Work. The Contractor shall furnish to the City certified copies of all required factory and mill test reports.

67. Deviation Allowed

I. Finished surfaces in all cases shall conform to lines, grades, cross sections and dimensions shown on the approved Construction Drawings and shall be within the tolerances given in the Project Specifications.

II. Deviations from the approved Construction Drawings, Shop Drawings, or other Contract Documents as may be required by the exigencies of construction shall, in all cases, be promptly determined by the City and authorized in writing. If the City deems it inexpedient to correct Work injured or done in an unauthorized manner, an equitable deduction from the Contract Price of the Work done shall be made by it subject to the approval of the Engineering Manager by Field Order or Change Order.

68. Preconstruction Meeting

Before the Contractor begins Work, the City shall schedule and conduct a preconstruction meeting. At the preconstruction meeting the Contractor shall name its Project Manager and Superintendent, be prepared to discuss the project construction schedule, traffic control plan and other project related issues, coordinate work activities and schedules to accommodate any utility relocations that may be required, establish procedures for the request of partial payments and for preparing/reviewing Shop Drawings and other submittals.

VIII. CHANGES IN WORK OR CONTRACT PRICE

69. Allowance for Change

I. Emergencies. In emergencies affecting the safety of persons, the Work, or property at the site or adjacent thereto, the Contractor, without special instruction or authorization from the City, is obligated to act at its discretion to prevent threatened damage, injury or loss. It shall give the City prompt written notice of any significant changes in the Work or deviations from the Contract Documents caused thereby. If the Contractor believes that Additional Work done by it in an emergency which arose from causes beyond its control entitles it to an increase in the Contract Price or an extension of the Contract Time, the Contractor may make a request therefore on a Request for Adjustments form.

II. Changed Conditions. Should the Contractor encounter or the City discover during the progress of the Work subsurface or latent physical conditions at the site differing materially from those indicated in the Contract Documents; or unknown physical conditions at the site of an unusual nature differing materially from those ordinarily encountered and generally recognized as inherent in work of the character provided for in the Contract Documents, the City shall be promptly notified in writing of such conditions. The City shall thereupon promptly investigate the conditions and if it finds they do materially differ and merit an increase or decrease in the cost, or the time required for performance of the Contract, an equitable adjustment shall be made and the Contract modified in writing accordingly.

III. Other Changes. It may become desirable or necessary to change or add to the Work covered by this Contract in order to complete the Project. The City may, at its discretion, require the Contractor to proceed with such changes or additions to the Work. The Contractor shall not, however, perform such Extra Work and furnish such extra materials prior to receiving a written order from the City.

IV. Variation From Contract Quantities. The Contractor shall not exceed the quantity of any Contract pay item without a prior written order from the City. Any increase in the quantity of a Contract pay item shall be requested in writing prior to the performance of the particular Work or placement of the material. This provision shall not apply to increases that are less than \$500 for a particular contract pay item and the total increase in cost of all pay items does not exceed the Contract price.

70. Limitations and Conditions of Change

I. Validity. Contract changes and directives which are made on approved forms shall not invalidate the Contract nor release the Surety. The Contractor shall perform the Work as altered, the same as if it had been a part of the original Contract. Such approved changes become a part of the Contract Documents.

II. 20 % Threshold. The City may find it advisable and has the right to omit portions of the Work and to increase or decrease quantities, and reserves the right to add to or take from any items as may be deemed necessary or desirable. If any such individual increase or decrease does not exceed twenty percent (20%) of the total monetary value of the original Contract, any claim made by the Contractor for any loss of anticipated profits because of any such alteration, or by reason of any variation between the

City of Grand Junction, Colorado
General Contract Conditions

approximate quantities and the quantities of Work as done, will not be accepted. If such changes are in excess of the twenty percent (20%) specified above, and if any claim is made because of increased or decreased cost of doing the Work occasioned by such excess, the Contractor shall file a complete cost statement showing in detail all costs in connection of such Work. Then if, in the opinion of the City, an adjustment is warranted, it shall be made only on that portion of the Work involved in the excess of the twenty percent (20%) increase or decrease.

III. Elimination of Completed Work. In case the City shall make any modifications, changes or alterations which would replace or otherwise make useless any Work done under the terms of the Contract, the City shall pay: (a) for any items of Work that have been partially or completely completed in accordance with the Contract prices for such work; (b) for removal of the Work, based on contract prices if available, and if not, on a time and materials basis plus 15% for profit and overhead.

IV. General Contractor as Agent. The City shall negotiate payment for all changes and Extra Work directly with the General Contractor. The General Contractor shall be responsible for the contracts and payments to its Subcontractors.

V. Bond Changes. It is the Contractor's responsibility to notify its Surety of any changes affecting the general scope of the Work or changes in the Contract Price and the amount of the applicable Bonds shall be adjusted accordingly. If the City and the Contractor agree that an adjustment is warranted such that the dollar amount of the Contract will be exceeded by greater than twenty per cent (20 %), the City and the Contractor must agree on an adjusted price for such additional work, which can only be authorized by a written Change Order. Additional costs, if any, of bonding due to additional authorized Work shall be paid by the City. The City may require proof of such incremental or additional costs of bonding.

71. Required Change of Work Forms

I. Use of Forms. With the exception of emergencies as described in Section 69 above, any Extra or Additional Work that is performed by the Contractor before receiving written directives from the Engineer on approved forms as contained in the Standard Contract Documents for Capital Improvements Construction shall be at its own expense. The Engineer shall promptly act on the Contractor's request for any such Extra or Additional Work. Payment therefore shall not be made, nor shall the Contractor have claim for reimbursement thereof.

II. Field Order. The City may authorize changes to, or direct minor variations in, the Work specified in the Contract Documents which do not involve an adjustment in the Contract Price or the Contract Time, and are consistent with the overall intent of the Contract Documents. These may be accomplished by a Field Order and shall be binding on the City and on the Contractor who shall perform the Work involved. If the Contractor believes that a Field Order justifies an increase in the Contract Price or an extension of the Contract Time, the Contractor shall make a request therefore by submitting to the Engineer, a Request for Adjustment form or other written request therefor within five (5) Working Days of the date of issuance of the Field Order.

City of Grand Junction, Colorado
General Contract Conditions

III. Work Change Request. The City may desire to make a change in the Work described in the Contract Documents. A Work Change Request shall be used to inform the Contractor of desired changes, and to direct the Contractor to submit a Request for Adjustment for the proposed Work. The City may or may not direct the Contractor to proceed with the Work changes. The work may be authorized by a Change Order or, if circumstances require (for example in order to avoid delay or stoppage of the Work, or to avoid a hazardous condition), the Engineer may authorize the Contractor to proceed by use of a Work Change Authorization, notwithstanding Sections 69 and 71. The Work Change Authorization does not change the Contract Price or the Contract Time, but is evidence that the parties expect that the change(s) directed or documented by the Work Change Authorization, if done, shall be incorporated in a subsequently issued Change Order following negotiations by the parties as to its effect, if any, on the Contract Price or Contract Time.

IV. Request for Adjustments. Prior to or during the course of construction, Additional Work may be required which the Contractor believes provides justification for a change of Contract Price or Contract Time, or both. These may include, but are not limited to: emergencies, changed conditions from those indicated in the Contract Documents and which would not ordinarily be encountered in the Work being performed; or the City's interpretations or directives provided on a Work Change Request; changes in the quantity of any contract item or items listed on the Bid Schedule which in aggregate, result in an increase in the total contract price, as further described in Section 70 above. No change in Contract Price or Contract Time shall be considered or authorized unless a Request for Adjustment form is submitted to the City:

- a) Within two (2) Working Days of the Emergency or discovery of changed conditions which has resulted or may result in Additional Work; or
- b) Within five (5) Working Days after the issuance of a Field Order or Work Change Request, or other event which causes the Contractor to believe that an adjustment is merited; or
- c) Five (5) working days in advance of any non-emergency work that would result in and increase the Contract Price.

A Request for Adjustment may be authorized by a Change Order or a Work Change Authorization.

V. If the City determines that the facts justify such action, Requests for Adjustment may, at the City's sole discretion, be received and considered later than as stipulated above. With the approval of the City Manager or his duly authorized representative, the City may recognize any such request asserted at any time prior to the date of final settlement of the Contract. Notwithstanding, nothing provided in these conditions shall excuse the Contractor from proceeding with the performance of the Work.

VI. Method of Payment. A method of increased or decreased compensation must be established and agreed upon for every Change Order that changes the Contract Price. Only the method of payment indicated on the Change Order and agreed to by both parties is binding under the Contract Documents. The Work Change Request and

City of Grand Junction, Colorado
General Contract Conditions

Request For Adjustment forms both provide information regarding method of payment to help expedite agreement on the means of financial compensation for changes. If a change is originated by the City's Work Change Request, the City shall on the form thereof, indicate its recommended method of payment and adjustments of Contract Time, if any. The Contractor shall in submitting a Request for Adjustment and on the form thereof, indicate the method of payment which it would propose for the Additional Work. If the claim is submitted in response to the City's request, the Contractor shall consider the City's recommended method of payment. However, the Contractor may propose a method of payment that is different than that recommended by the City.

The four (4) methods of payment allowed under this Contact are described as follows:

1. By unit prices for the same class Work included in the Contract; or
2. By agreed unit prices; or
3. By agreed lump sum; or
4. The Contractor shall be paid the "Actual Cost" of the Work plus overhead and profit as provided below.

Where Extra Work is paid for under Method 4, the term "Actual Cost" of such Extra Work is hereby defined to be the following:

- (a) Direct Labor. Actual net direct increase or decrease in the cost of the Contractor's labor for all work associated with the change. Contractor's labor shall be limited to labor (including salaried field personnel) that performs the individual change in the Work full-time.
- (b) Labor Burden. Contractor's actual costs for worker's compensation and liability insurance, payroll taxes, social security and employee's fringe benefits (including employer paid health insurance) imposed on the basis of payrolls. This burden must reflect the variability of some burdens, e.g., social security. The burden shall include all small tools which cost less than \$200 apiece.
- (c) Direct Material, Supplies, Installed Equipment. Actual net direct costs of materials, supplies and equipment incorporated in or consumed by the work. If actual costs are not available, the cost shall be the lowest commercially available price including all discounts and rebates and all applicable taxes. Cost shall be based on buying the material, supplies and equipment in the largest practical quantity to receive quantity discounts.
- (d) Equipment. Actual net cost to the Contractor of owned and/or rented equipment other than small tools, to be determined using the following methods:

City of Grand Junction, Colorado
General Contract Conditions

1. Owned equipment costs, including operating costs, shall be determined in accordance with the requirements and provisions applicable to owned equipment and extra work contained in the current edition of the Rental Rate Blue Book for Construction Equipment published by Primedia Information Inc. If the City and Contractor agree on owned equipment costs, those costs shall be used. However, if there is no agreement, the Rental Rate Blue Book shall be used.
 2. Rental equipment costs shall be determined using actual invoiced rates less all discounts for bare equipment rental. Operating costs will be determined based on rates in the above-cited Rental Rate Blue Book.
 3. Mobilization/demobilization costs shall be paid if the equipment is mobilized exclusively for work described in a Change Order. If the equipment is used on base contract work, no mobilization or demobilization cost shall be paid. Mobilization/demobilization cost shall be based on using the least expensive means to mobilize or demobilize. Equipment shall be obtained from the nearest available source. When the least expensive methods are used, then costs shown in the actual invoice shall be the basis for pricing.
- (e) Bonds, Insurance, Permits and Taxes. Actual increase or decreases in the cost of premiums for all bonds and insurance, permit fees, and sales, use or similar taxes related to the work.
- (f) Subcontract Costs. Net cost of Subcontractor work at any tier, provided that the cost of the Subcontractor is determined in accordance with the above requirements. When possible, the Contractor shall obtain quotes from more than one Subcontractor.
- (g) Overhead and Profit.
1. Twelve percent (12%) of the sum of Subparagraphs (a) through (e) above, to cover a Contractor's or Subcontractor's overhead and profit for work performed by that Contractor or Subcontractor.
 2. Three percent (3%) of Subparagraph (f) above to cover Contractor's overhead and profit for overseeing work performed by Subcontractors at any tier.
 3. Neither the Contractor nor any Subcontractor, nor the City in the case of a credit, shall attempt to apply these percentage adjustments in a way which would pyramid either the cost or credit because a Subcontractor or Subcontractors at any tier are involved.

City of Grand Junction, Colorado
General Contract Conditions

4. The overhead and profits payments provided for in this subparagraph to be paid to the Contractor shall cover and be compensation for the Contractor's profit, home office overhead, general superintendence, and field office expense, and all other elements of costs not embraced within the actual costs as defined above.

IX. CHANGES IN CONTRACT TIME

72. Extension of Contract Time

I. The Contract Time may only be changed by a Change Order. Any Request For Adjustment of the Contract Time shall be in writing delivered to the City within the time limit as stipulated for changes in Contract Price. Any change in the Contract Time resulting from any such Request shall be incorporated in a Change Order.

II. The Contractor shall be considered as having taken account, when submitting its Bid, which becomes a part of the Contract, all hindrances and delays incident to the Work, whether growing out of delays in securing material or workers, inclement weather, or otherwise. Should the need for further extensions be necessary, Contractor shall contact the City to request such reasonable extensions. In the case of inclement weather, should the Contractor and the City be unable to agree on the necessity for an extension of time, then an extension of time shall be granted only after taking into consideration the average of the preceding ten (10) years' climatic range during the specified Contract Time based on statistics of the National Weather Service for the locality where the Work is performed and usual climatic conditions prevailing in such locality. The amount of Contract Time allowed for such extension shall be determined from the Inspector's daily inspection reports. Regardless of actual weather conditions, any day in which the Contractor is able to work eighty (80) percent or more of its scheduled work force shall not be counted as an inclement weather day for purposes of calculating a weather-related extension of the Contract Time. The existence of inclement weather shall not relieve the Contractor of the burden of proving that the inclement weather delayed specific activities that were on the then-current critical path that controlled the overall completion of the Work.

III. The right of the Contractor to proceed shall not be terminated, nor will the Contractor be charged with Liquidated Damages because of any delays in the completion of the Work due to causes that are beyond the control of the Contractor and which the City shall decide could not have been anticipated or avoided. An extension of time shall only be granted by the City in such amount of time to be determined by the City. The Contractor shall give the City notice in writing within five (5) days from the beginning of any delay or when Contractor is made aware of such delay and the cause thereof.

IV. The Contractor shall support any request or proposal for an adjustment in Contract Time with a schedule analysis which shows how and where a delay on the critical path of the Project occurs and shall affect the Contract Time. This submittal shall include a description of the Contractor's effort to reschedule work in order to mitigate the effect of the changes on the schedule.

V. If the parties cannot reach agreement and the Contractor otherwise complies with the requirements of these Contract Documents, the City shall ascertain the facts and the extent of the delay and extent of time for completing the Work when, in its judgment, the finding of facts justify such an extension. The City's finding of facts thereon shall be final and conclusive on the parties hereto, subject only to appeal, within thirty (30) days, by the Contractor to the City Manager.

City of Grand Junction, Colorado
General Contract Conditions

VI. Failure to strictly comply with the timing and submittal requirements of this section shall constitute a waiver of any request for an extension of the Contract Time.

VII. All Contract Time extensions shall be by written Change Order. No oral time extensions shall be granted by the City or relied upon by the Contractor.

73. Delays and Liquidated Damages

I. If the Contractor refuses or fails to prosecute the Work, or any part thereof, with such diligence as shall insure its completion within the time specified in the Special Conditions or any extension thereof or fails to complete said Work within such time, the City may, by ten (10) Working Days written notice to the Contractor and its Sureties, terminate its right to proceed with the Work or such part of the Work as to which there has been a delay.

II. In the event of delays as described above, the City may take over the Work and prosecute the same to completion, by contract or otherwise. The Contractor and its Sureties shall be liable to the City for any excess cost occasioned the City. If the Contractor's right to proceed is so terminated, the City may take possession of and utilize in completing the Work all such of the materials purchased by Contractor for this Project, including but not limited to, materials, appliances, equipment, tools, machinery, and plants as may be on the site of the Work and necessary therefore. The right of the Contractor to proceed shall not be terminated because of any delays in the completion of the Work due to causes beyond the control and without the fault or negligence of the Contractor, such as acts of God or of the public enemy, acts of the City, freight embargoes, strikes, or delays of other contractors due to such causes.

III. Liquidated Damages. If the Contractor does not achieve Final Completion by the required date, as the City may extend such date in writing, and the City does not terminate the contract as provided for in paragraphs I and II above, whether by neglect, refusal or any other reason, the parties agree and stipulate that the Contractor shall pay liquidated damages to the City for each day that final completion is late. As provided elsewhere, this provision does not apply to delays caused by the City.

The Contractor agrees that as a part of the consideration for the City's awarding of this Contract liquidated damages in the amount specified in the Special Conditions is reasonable and necessary to pay for the actual damages resulting from such delay. The parties agree that the real costs and injury to the City for such delay include hard to quantify items such as: Additional engineering, inspection and oversight by the City and its agents; additional contract administration; inability to apply the efforts of those employees to the other work of the City; perceived inefficiency of the City; citizens having to deal with the construction and the Work, rather than having the benefit of a completed Work, on time; inconvenience to the public; loss of reputation and community standing for the City during times when such things are very important and very difficult to maintain.

The Contractor must complete the Work and achieve final completion included under the Bid Schedule in the number of consecutive calendar days after the City gives is written Notice to Proceed. When the Contractor considers the entire Work ready for its intended use, Contractor shall certify in writing that the Work is substantially complete. In addition to the Work being substantially complete, Final Completion date is the date by which the

City of Grand Junction, Colorado
General Contract Conditions

Contractor shall have fully completed all clean-up, and all items that were identified by the City in the inspection for final completion. Unless otherwise stated in the Special Conditions, for purposes of this liquidated damages clause, the Work shall not be finished and the Contract time shall continue to accrue until the City gives its written Final Acceptance.

If the Contractor shall fail to pay said liquidated damages promptly upon demand thereof after having failed to achieve Final Completion on time, the City shall first look to any retainage or other funds from which to pay said liquidated damages; if retainage or other liquid funds are not available to pay said liquidated damages amounts, the Surety on the Contractor's Performance Bond and Payment Bond shall pay such liquidated damages. In addition, the City may withhold all, or any part of, such liquidated damages from any payment otherwise due the Contractor.

Liquidated damages as provided do not include any sums to reimburse the City for extra costs which the City may become obligated to pay on other contracts which were delayed or extended because of the Contractor's failure to complete the Work within the Contract Time. Should the City incur additional costs because of delays or extensions to other contracts resulting from the Contractor's failure of timely performance, the Contractor agrees to pay these costs that the City incurs because of the Contractor's delay, and these payments are separate from and in addition to any liquidated damages.

The Contractor agrees that the City may use its own forces or hire other parties to obtain Substantial or Final Completion of the work if the time of completion has elapsed and the Contractor is not diligently pursuing completion. In addition to the Liquidated Damages provided for, the Contractor agrees to reimburse the City for all expenses thus incurred.

X. CLAIMS

74. Notice of Intent to Claim

I. If after receiving a decision from the City that a Change Order shall not be issued, as requested by the Contractor, or the Contractor does not agree with the City's decision on a change in price or time and the Contractor intends to submit a claim therefor, the Contractor shall submit in writing a Notice of Intent to Claim to the City. A Notice of Intent to Claim for change in price or time cannot be filed unless a Request for Adjustment has first been made in accordance with Section 70.

II. The written Notice of Intent to Claim shall be clearly titled as such and all Notices shall be numbered sequentially. The Notice shall contain the following:

- (a) Date of the event giving rise to the claim.
- (b) A description of the claim.
- (c) The reasons why the Contractor believes additional compensation or time is due or charges were wrongly assessed.
- (d) An estimate of any additional costs associated with the claim.
- (e) The Contractor's plan for mitigating costs or delays associated with the claim.

III. The Notice of Intent to Claim described above shall be given within ten (10) days after denial of any request for a change in the Contract Amount or Contract Time contained in a Request for Adjustment.

75. Submittal of Claim

I. The Contractor shall, within twenty (20) days after it submits a Notice of Intent to Claim, submit to the City a complete and itemized claim which includes any claimed increase in Contract Time and Contract Amount. The Contractor may request an extension of time to submit the claim, which extension may be granted by the City for good cause shown. The claim must be described in sufficient detail to allow the City to evaluate the basis of and costs associated with said claim. A claim for increase in Contract Amount shall be submitted based on actual costs whenever possible, rather than estimate or opinion, and shall be supported by invoices, time cards, and other business records commonly accepted in the industry. The claim shall be accompanied by copies of all contract provisions or other documents relied on and a summary of the legal and factual theories supporting the claim. A claim for time extension must be accompanied by a revised construction schedule reflecting the effects of the delay on the critical path and showing actions which the Contractor has taken or proposes to take to minimize the effects of the delay. The claim shall also identify any measures the City can take to minimize the claim.

II. The Contractor shall furnish upon request all additional information and data which the City determines is needed to aid in resolving the claim through negotiation or which

City of Grand Junction, Colorado
General Contract Conditions

is required to complete an evaluation of the claim. The Contractor shall give the City access to its books, correspondence, records and other materials relating to the work described in the claim, shall require its Subcontractors and suppliers to provide the City with such access, and shall make its personnel and that of its Subcontractors and suppliers available to discuss and answer cost, schedule and other questions related to its claim. Clear copies of all necessary supporting records shall be provided to the City at no cost. Failure to submit requested information may be the basis for denial of a claim.

III. Failure to submit the claim in writing within the time and in the manner described above, or within such extended time granted by the City, shall constitute a waiver by the Contractor of any right equitable or otherwise to make such claim.

IV. The Contractor shall submit with its claim a sworn and notarized certificate that:

- (a) The claim is made in good faith;
- (b) All supporting data are accurate and complete to the best of the Contractor's knowledge and belief;
- (c) The amount requested is not overstated or inflated and fairly and accurately reflects that contract adjustment for which the Contractor believes the City is liable; and
- (d) The prices stated for material and equipment are the lowest reasonably available to the Contractor and include all available discounts.

V. If the Contractor is an individual, that individual shall execute the certification. If the Contractor is not an individual, the certification shall be executed by (i) a senior company official in charge of the work performed under this Contract; or (ii) an officer or general partner of the Contractor.

VI. The City or its designee shall investigate, review and evaluate the claim and make a determination. Such determination shall be made in writing within thirty (30) days of receipt of a completed and fully-documented claim; however, if special circumstances exist or the claim is unusually complex, the Contractor shall be notified of a longer period.

VII. The Contractor shall proceed diligently with performance of this Contract, pending final resolutions of any claim made under this Section, and shall comply with any decision of the City pending final resolution of the claim. Failure to proceed with the work shall be grounds for suspension or termination of the Contractor. Any dispute regarding decision of the City shall be handled pursuant to Article XV. Disputes.

VIII. If the Contractor agrees with any determination or resolution by the City requiring a change in Contract Time or Amount, it shall be processed as a Change Order.

City of Grand Junction, Colorado
General Contract Conditions

IX. Failure to meet any of the requirements of this Section in a timely and complete manner shall constitute a waiver by the Contractor of any right to adjustments of Contract Time or Amount either by administrative review or by any other action at law or equity.

XI. WARRANTY AND GUARANTEE

76. Contractor's Warranty and Guarantee

I. The Contractor warrants and guarantees to the City that all materials and equipment shall be new, unless otherwise specified, suitable for the purpose used, and shall be of good quality and free from faults or defects and in accordance with the requirements of the Contract Documents and of any inspections, tests or approvals required.

II. The Contractor further warrants that it has full title to all equipment, components and other items conveyed to the City under the terms of this Contract, that its transfer of such title to the City is rightful and that all such equipment, components and other items shall be transferred free and clear from all security interests, liens, or encumbrances, whatsoever. The Contractor agrees to warrant and defend such title against all persons claiming the whole or any part thereof at no cost to the City.

III. All Subcontractors,' manufacturers' and suppliers' warranties and guarantees, expressed or implied, for any part of the Work and any materials used therein shall be obtained and enforced by the Contractor for the benefit of the City whether or not such warranties have been assigned or otherwise transferred to the City. The Contractor shall assign or transfer such warranties and guarantees to the City if the City requests the Contractor to do so, but such transfer shall not affect the Contractor's obligation to enforce such warranties and guarantees on the City's behalf.

IV. After approval of final payment and prior to the expiration of the Warranty Period, if any work is found to be defective, the Contractor shall promptly, without cost to the City and in accordance with the City's written instructions, either correct such Defective Work, or, if it has been rejected by the City, remove it from the site and replace it with non-Defective Work.

The Warranty Period is one year after the date of Final Completion and Acceptance unless specified otherwise in the Special Conditions. If only a portion of the Work is defective, the Warranty shall be extended for an additional one year period following Acceptance of the correction, repair or replacement of the portion or segment of the Work.

V. If within ten (10) days after written notice by the City to the Contractor, or its agent, requesting such repairs or replacement, the Contractor shall neglect to make or undertake with due diligence to do the same, the City may make such repairs or replacement in accordance with the terms of the Contractor's Performance Bond at the Contractor's and/or Surety's expense, provided, however, that in the case of emergency where, in the judgment of the City, delay would cause serious loss or damage, repairs or replacement may be made without notice being sent to the Contractor. The Performance Bond shall expire upon the expiration of the Warranty Period.

VI. The duties and obligations imposed by these General Contract Conditions and the rights and remedies available hereunder and, in particular but without limitation, the warranties, guarantees and obligations imposed upon the Contractor and the remedies available to the City thereunder, shall be in addition to and not a limitation of any

City of Grand Junction, Colorado
General Contract Conditions

otherwise imposed or available by law, by special guarantee or other provisions of the Contract Documents.

VII. Nothing herein shall be construed to establish a period of limitation with respect to any other obligation which the Contractor may have under the Contract Documents. The establishment of the warranty period set forth above relates only to the specific obligations of the Contractor to correct known defects in the Work which are discovered and called to the Contractor's attention during the warranty period, and has no relationship to the time within which its obligation to comply with the Contract Documents may be sought to be enforced, nor to the time within which proceedings may be commenced to establish the Contractor's liability with respect to its obligations and resulting damages. Nothing herein shall limit the City's right to seek recovery for latent defects which are not observable until after the warranty periods have run.

VIII. Portions of the work may be accepted by the City for warranty purposes upon substantial completion and when the City finds it to be of benefit to place that unit of work in service. A later warranty period shall begin upon Final Completion and Acceptance for those items not previously completed.

XII. MEASUREMENT, PAYMENT AND ACCEPTANCE

77. General Measurement and Payment Issues

I. Bid Schedule Quantities. Estimated quantities listed in Bid Schedules shall not govern final payment. Said payment shall be once each month unless otherwise approved by the City. The City shall make all measurements and determine all quantities and amounts of work done under the Contract. At the time measurements are made for quantity determinations, the Contractor or its authorized assistant shall be present to verify such measurements. Whenever applicable, Contractor shall adhere to the provisions in Section VIII referring to changes in Work or Contract Price.

II. Unauthorized and Non-Conforming Materials and Work. Payment shall not be made for materials wasted, placed or installed in a manner not called for under the Contract Documents. This includes rejected material not unloaded from vehicles, material rejected after it has been unloaded or placed, and material placed outside of the plan lines. Compensation shall not be made for disposing of rejected or excess material, nor for Defective Work.

III. Limitations of Payment. Payment shall not relieve the Contractor from contractual obligations, nor shall such payment be construed to be acceptance of any of the Work. Payment shall be construed as the transfer of ownership of any non-defective equipment or materials to the City.

IV. Contractor's Responsibility. Responsibility shall remain with the Contractor who shall be obligated to store, protect, repair, replace, rebuild or otherwise restore any fully or partially completed Work or structure for which payment has been made, or replace any materials or equipment required to be provided under the Contract which may be damaged, lost, stolen or otherwise degraded in any way prior to acceptance of the Work under the Contract.

V. Extra or Changed Work. Unless a written Change Order is approved, extra or changed Work, or Work due to unforeseen circumstances, or Work requiring blasting, rock excavation, or other severe conditions, shall not be paid for, and shall be at the Contractor's expense.

78. Partial Payments

I. Partial payments shall be based upon written estimates, prepared by the Contractor, of the value of Work performed and materials placed in accordance with the Contract Documents. Said payments shall be made no more than once each month, unless otherwise approved in advance by the Engineering Manager.

II. Estimates for partial payment shall be prepared on, or in the format of, the Request For Payment form, a copy of which is provided in the Standard Forms contained in this document.

III. The City may establish a closure date for the purpose of receiving monthly applications for payment from the Contractor. The Contractor may at any time request in

City of Grand Junction, Colorado
General Contract Conditions

writing that the monthly closure date be changed. The City may approve such request when the request is compatible with the City's payment policy and procedures.

IV. The processing of Requests for Payment which are received after the specified closure date may be delayed until the closure date of the following month.

V. Requests for Payment shall be completed according to the pay items, pay units, and unit prices listed in the Bid Schedule. Lump sum pay items may be estimated according to the percentage of each item completed.

VI. All applications for payment are subject to review and approval by the City. Pay estimates which exceed the value of Work performed and/or materials installed for the pay period may be reduced or rejected.

VII. If payment is requested on the basis of materials and equipment delivered, but not incorporated in the Work, the application shall be included on the Request For Payment form. This form shall be accompanied by an invoice, proof of payment and other documentation for each item as required to establish the City's title to the material or equipment and protect its interest therein, including appropriate insurance.

VIII. After each application for payment has been certified by the City and approved by the Manager, the City shall pay to the Contractor partial payment minus retainage as specified herein.

IX. Partial payments shall be made within ten (10) days after the closure date. If the City shall at any time fail to make the Contractor a payment at the time herein specified, such failure shall not be held to invalidate or void this Contract.

79. Retainage

The amount to be retained from partial payments shall be ten (10) percent of the total value of the work completed as determined from the cumulative requests for payment until fifty (50) percent of the work required by the contract has been performed. Thereafter the City shall pay any of the remaining installments without retaining additional funds if in the opinion of the City satisfactory progress is being made in the work. The withheld percentage shall be retained until the contract is satisfactorily completed and finally accepted by the City. If the City finds that satisfactory progress is being made in all phases of the Contract it may upon written request by the Contractor authorize payment from the withheld percentage to the Contractor or subcontractors that have completed their work in a manner finally acceptable to the City. Before such payment is made the City shall determine that satisfactory and substantial reasons exist for the payment and shall require written approval from any surety furnishing bonds for the contract work. Whenever a Contractor receives payment pursuant to this section the Contractor shall make payments to each of his subcontractors in accordance with 24-91-103 C.R.S. The determination of satisfactory progress shall be made in the sole discretion of the City.

80. Notice of Substantial Completion

I. When the Contractor considers the Work substantially complete, the Contractor shall make a written request to the City for the issuance of a Notice of Substantial Completion.

City of Grand Junction, Colorado
General Contract Conditions

The City, upon receipt of the written request, shall conduct an inspection of the Work and either issue a written Notice of Substantial Completion or deny the Contractor's request and provide the reasons for such denial.

II. In the case of a denial of the issuance of a Notice of Substantial Completion, the Contractor shall complete the Work so as to address the City's concerns and comply with the Contract Documents and shall again request in writing that the City issue a written Notice of Substantial Completion. The City shall handle any subsequent requests as outlined above for the first request.

III. If the City grants the Contractor's request and issues a Notice of Substantial Completion, the Notice shall list any remaining items to be completed as "Punch List" items. Upon completion of the Punch List items, the Contractor shall make written application to the City for final inspection and acceptance of the Work.

81. Final Estimate and Payment

I. After the City has accepted the Work, it shall prepare a final estimate of the work done under the Contract and the value thereof, including all Extra Work properly authorized and performed in connection therewith. All prior estimates and payments shall be subject to correction in the final estimate and payment. From the total amount of the final estimate, there shall be deducted first, all previous payments made to the Contractor under the Contract, and second, all damages and other charges properly chargeable to the Contractor under the terms of the Contract. The balance, if any, shall be paid to the Contractor; provided, however, that prior to delivery to the Contractor of the final payment, the Contractor shall first furnish the City proof in affidavit form (lien waiver) that all claims, liens, or other obligations incurred by it and all of its subcontractors in connection with performance of the Work have been properly paid and settled. Information regarding such obligations shall be sworn to by the Contractor and shall include authorization of the Surety on the Performance and Payment Bonds to allow the City to make final settlement with the Contractor. Also, at the time of delivery to the Contractor of the final payment, the Contractor shall execute and give to the City a Final Receipt and Release form provided in the Standard Forms.

II. In the event there are at the time set for final settlement outstanding claims against the Contractor or its Subcontractors, or for any other reason the Contractor is unable to give a proper affidavit that liens or other obligations have been properly paid and settled, the City Manager, in his sole discretion, may waive the requirement of the said affidavit provided the Surety on the Performance and Payment Bonds agrees to the City making final settlement without in any way lessening or modifying the Surety's liability under such Performance and Payment Bonds. Further, when final settlement is made the City shall withhold from payment any funds it may be required by law to withhold, and final payment shall not be made until in the determination of the City Manager all conditions of law have been met.

III. The City shall not make final settlement until any and all public legal advertisements have been made.

82. Acceptance of Work

I Partial Acceptance. If at any time during the prosecution of the Project, the Contractor substantially completes a unit or portion of the Project, and if the City finds it to be in the City's benefit to place that unit into service, the City may make an inspection of that unit. If the City finds upon inspection that the unit has been satisfactorily completed in compliance with the Contract, it may issue a written Notice of Partial Acceptance accepting that unit or portion of the Work. Such partial acceptance shall in no way void or alter any of the terms of the Contract.

II Final Acceptance. Upon due notice from the Contractor of presumptive completion of the entire Project, the City shall make an inspection. If all construction provided for and contemplated by the Contract is found completed to its satisfaction, that inspection shall constitute the final inspection and the City shall make the final acceptance and issue the Contractor a Notice of Final Acceptance effective on the date of final inspection.

If, however, the inspection discloses any Work, in whole or in part, as being unsatisfactory, the City shall give the Contractor the necessary instructions for correction of same, and the Contractor shall immediately comply with and execute such instructions. Upon correction of the Work, another inspection shall be made which shall constitute final inspection provided the Work has been satisfactorily completed. In such event, the City shall make the final acceptance and notify the Contractor in writing of this acceptance as of the date of final inspection.

The Contractor's obligation to perform the Work and complete the project in accordance with the Contract Documents shall be absolute. Neither approval of any partial or final payment by the City, nor any payment by the City to the Contractor under the Contract Documents, nor any use or occupancy of the project or any part thereof by the City, nor any act of acceptance by the City, nor any failure to do so, nor any correction of Defective Work by the City shall constitute an acceptance of Work not in accordance with the Contract Documents.

XIII. SUSPENSION OF WORK AND TERMINATION

83. Suspension of Work

I. The City may, at any time and without cause, suspend the Work or any portion thereof for a period of not more than ninety (90) days by notice in writing to the Contractor by the City which shall fix the date on which Work shall be resumed. The Contractor shall be allowed an increase in the Contract price or an extension of the Contract Time, or both, directly attributable to any suspension if it makes a request therefore as provided.

II. Such order by the City shall not otherwise modify or invalidate in any way any of the provisions of the Contract.

84. Contract Default and Termination of Contract by City

I. The City Manager may serve ten (10) days written notice upon the Contractor of the intent to declare the Contractor in default and/or terminate the Contract, if: 1) the Work to be performed under the Contract is assigned by the Contractor other than provided for herein; 2) the Contractor is adjudged as bankrupt; 3) a general assignment of its assets be made for the benefit of its creditors; 4) a receiver is appointed for the Contractor or any of its property; 5) the performance of the Work under the Contract is being unnecessarily delayed or that the Contractor is willfully violating any of the conditions, provisions, or covenants of the Contract, or that it is executing the same in bad faith or otherwise not in accordance with the terms of the Contract; 6) the Work is not fully completed within the time named for its completion or within the time to which such completion date may be extended; or 7) if other just causes exist. If the Contractor shall not, prior to the effective date set forth in such notice, take such measures as shall, in the judgment of the City, insure the satisfactory performance of the Work, the Engineering Manager and the City Manager may declare the Contractor in default and/or declare the Contract terminated on the Effective Date specified in such notice, or any date subsequent thereto. In the event of such default or termination, the City shall notify the Contractor to discontinue all Work under the Contract. Upon such default or termination, the City may take possession of all such materials, equipment, tools and plants as may be on the site of the Work and required or necessary for completion of the Work and take over the Work and prosecute the same to completion, by contract or otherwise, for the account and at the expense of the Contractor. The Contractor and its Surety shall be liable to the City for any and all costs and expenses in excess of the Contract price or prices sustained by the City by reason of such prosecution and completion, including all administrative costs and attorneys' fees in connection therewith.

II. Where the Contractor's services have been so terminated by the City, said termination shall not affect any rights of the City against the Contractor then existing or which may thereafter accrue. Any retention or payment of moneys by the City due the Contractor shall not release the Contractor from liability and all the Contractor's obligations under the Contract shall survive any such termination.

III. In the event a court of competent jurisdiction determines that any termination of Contractor pursuant to this paragraph was wrongful or inappropriate, said termination shall be deemed a Termination for Convenience pursuant to Article XIV and the rights and obligations of the parties shall be determined accordingly.

City of Grand Junction, Colorado
General Contract Conditions

XIV. TERMINATION FOR CONVENIENCE

85. Termination of Contract for Convenience

I. The performance of Work under this Contract may be terminated by the City in whole or in part whenever for any reason, in its sole discretion, City shall determine that such termination is in the best interest of the City or whenever the City is prohibited from completing the Work because of conditions beyond the control of either the City or the Contractor. Such termination shall be effected by giving not less than three (3) days written notice to the Contractor specifying the extent to which performance of work under this Contract is terminated and the date upon which such termination becomes effective.

Upon receipt of notice of such termination, the Contractor shall:

- (a) Stop Work as specified in the notice;
- (b) Terminate all orders and subcontracts except as necessary to complete Work which is not terminated;
- (c) If directed by the City, assign all right, title and interest in subcontracts and materials in progress, in which case the City shall have the right, in its discretion, to settle or pay any and all claims arising out of the termination of such subcontracts;
- (d) Settle outstanding liabilities and claims with the approval of the City or its designated representative;
- (e) Complete performance of such part of the Work as has not been terminated; and
- (f) Take such other actions as may be necessary, or as may be directed by the City, for the protection and preservation of the property related to the Contract.

II. Except as provided above, any inventory resulting from the termination of this Contract may, with written approval of the City, be sold or acquired by the Contractor under the conditions prescribed by and at prices approved by the City.

III. Upon receipt of the Notice of such termination, the Contractor shall submit to the City a request for payment of its termination costs, in the form and with certification prescribed by the City. Such request shall be submitted promptly but in no event later than thirty (30) days from the effective date of termination, unless extended in writing by the City upon the written request of the Contractor within such thirty (30) day period. However, if the City determines that the facts justify it, a request may be received and acted upon after thirty (30) days.

IV. The Contractor shall be entitled to receive reimbursement for the reasonable cost of the work and a proportion of the Bid profit as of the date of termination, including, a release of retainage. The City will additionally reimburse the Contractor for such other reasonable costs resulting from said termination such as restocking charges and

City of Grand Junction, Colorado
General Contract Conditions

protection of the Work. In the event of termination, the calculation of profit shall be based upon the percentage of Work completed in proportion to the Work contracted, including Changes. The Contractor shall not be entitled to loss of other anticipated profits, profits lost on other work not obtained or any other consequential damages, or any reimbursement for any costs incurred due to the contractor's fault or failure to mitigate, as a result of any such termination for convenience. In no event shall the total sums paid the Contractor exceed the Contract Amount.

In arriving at the amount due the Contractor under this Article, there shall be deducted:

- (a) All un-liquidated advance or other payments therefore made to the Contractor, applicable to the terminated portion of this Contract;
- (b) Any claim which the City may have against the Contractor in connection with this Contract;
- (c) The agreed price for, or the proceeds of sale of, any materials, supplies or other things acquired or sold by the Contractor or sold pursuant to the provisions of this Article not otherwise recovered by or credited to the City; and
- (d) Any outstanding Subcontractor claims.

V. The City may, from time to time, under such terms and conditions as it may prescribe, authorize partial payments and payments against costs incurred by the Contractor for the terminated portion of the Contract, if it is estimated that the total of such payments shall not exceed the amount to which the Contractor shall be entitled. If the total of such payments is in excess, the excess shall be payable by the Contractor to the City upon demand.

VI. A settlement for the work performed shall not relieve the Contractor or its Surety from responsibility for defective work and/or materials on the completed portion of the Work or for payment of labor and materials as guaranteed by the Payment and Performance Bonds.

VII. The City shall be given full access to all books, correspondence, records and other materials of the Contractor relating to this Contract in order to determine the amounts to be paid on account of the termination of the Contract. The Contractor shall, as requested by the City furnish clear copies of any such materials.

XV. DISPUTES

86. Disputes with the City

I. If the Contractor considers any work demanded of him to be outside the requirements of the Contract, or considers any record or ruling of the City or its Inspectors unfair, it shall immediately upon such work being demanded or such record or ruling being made, ask in writing, for written instruction or decision. It shall then proceed without delay to perform the work or to conform to the record or ruling. Within five (5) days after date of receipt of the written instructions or decision, it shall file a Request for Adjustment stating clearly and in detail the basis of its objection.

II. Except for such protests or objections as are made of record in the manner herein specified and within the time limit stated, the records, rulings, instruction, or decisions of the City shall be final and conclusive.

III. The rights and remedies of the City provided in the contract and the General and Specific Conditions to the Contract are cumulative to all other remedies provided by law. The City's rights and remedies include those afforded by law that are not stated therein. The Contractor specifically waives all provisions of Chapter 8, Article 20 of Title 13 C.R.S. regarding defects in the Work under the Contract.

87. Unresolved Disputes

I. If disputes remain unresolved, the Contractor and the City shall submit to non-binding mediation. If mediation is unsuccessful, the Contractor and/or the City expressly reserve(s) the right to file a civil action pursuant to the Colorado Rules of Civil Procedure.

II. The mediator shall be a neutral decision-maker with experience on municipal construction projects. The parties shall attempt to jointly select the mediator from a list of proposed mediators generated by the parties. The parties may seek the assistance of the American Arbitration Association in generating a list of potential mediators. In the event that the parties are unable to agree on a mediator, the City shall select the mediator. Each party shall bear its own costs associated with presenting any disputes to the mediator, which costs shall not be recoverable as part of a change order or in any subsequent litigation.

III. No decisions or statements of the mediator shall be admitted as evidence in any litigation between the parties nor shall the mediator be called to testify in any litigation between the parties concerning such disputes.

IV. The submittal of disputes to non-binding mediation shall be a condition precedent to commencing litigation by either party.

V. In the event any dispute, mediation or litigation arises under this Contract and during the time such dispute is pending, the Contractor hereby agrees that it shall continue performance under this Contract in accordance with the terms and conditions hereof since time is of the essence. The failure of the Contractor to continue expeditious performance due to a dispute arising under this Contract shall, at the option of the City,

City of Grand Junction, Colorado
General Contract Conditions

be construed as a material breach of this Contract justifying termination or such other action as the City deems appropriate.

XVI. TAXES

88. Sales and Use Taxes

I. Pursuant to the City's Sales and Use Tax Ordinance #2551:

MATERIALS:

II. The State of Colorado, Mesa County, and the City are exempt, from sales tax and use tax on construction materials and fixtures to be incorporated in projects for government agencies. This includes projects contracted with the City.

III. The construction materials and fixtures must become an integral and inseparable part of the finished project which then becomes property of the government agency.

IV. The State Exemption Identification must be obtained from the State and shall serve as proper exemption verification for the County **and City** as well. **The Contractor no longer needs to obtain a tax exempt project certificate from the City Finance Department.**

EQUIPMENT:

V. Construction equipment used on tax exempt projects **IS NOT** exempt from taxation. Sales tax must be paid to the vendor on any short term rentals of equipment. City use tax may be due on the Contractor's equipment used inside the City limits for which a prior City sales tax or use tax has not been paid. The Sales Tax Division of the City Finance Office 244-1520 or 244-1521 provides proper forms and procedures.

89. Accounting of Costs and Audit

I. The Contractor shall keep and maintain and shall cause its Subcontractors and outside consultants to keep and maintain books, records, accounts and other documents (hereinafter collectively referred to as "records") that are sufficient to accurately and completely reflect all costs incurred pursuant to this Contract, including costs which may be the basis of a Contractor Change Request or a claim by the Contractor. Such records shall include the bid estimate and all bid work papers and take-offs, receipts, memoranda, vouchers, and accounts of every kind and nature pertaining to the performance of the work, including but not limited to job cost ledgers, invoices from and payments to Subcontractors, material purchases, records of home and field office overhead, as well as complete summaries and reports setting forth all reimbursable man-hours expended and payroll and equipment records. All such records shall be kept for three (3) years from the date of Final Completion.

II. The City and any firm of auditors retained by the City shall have access, upon reasonable advance notice in writing, to all such records maintained by the Contractor and its Subcontractors and consultants, for the purpose of auditing and verifying Contractor's costs or any other costs claimed to be due and payable hereunder.

III. The Contractor shall include in all Subcontracts, consulting agreements and any other agreements entered into by the Contractor for the performance of the Work a provision to the effect that its Subcontractors, consultants or other parties shall observe

City of Grand Junction, Colorado
General Contract Conditions

and comply with all obligations of Contractor under this provision in the same manner and to the same extent as Contractor.

ENGINEERING DIVISION



STANDARD SPECIFICATIONS FOR ROAD AND BRIDGE CONSTRUCTION

REVISED JULY, 2010

CITY OF GRAND JUNCTION, COLORADO
DEPARTMENT OF PUBLIC WORKS AND PLANNING
ENGINEERING DIVISION

**STANDARD SPECIFICATIONS FOR
ROAD AND BRIDGE CONSTRUCTION**

TABLE OF CONTENTS

GENERAL 1

QUALITY CONTROL AND QUALITY ASSURANCE 2

 TABLE 1 – REQUIRED QUALITY ASSURANCE (QA) AND 3

 QUALITY CONTROL (QC) TESTING..... 3

SECTION 101 - DEFINITIONS AND TERMS 5

101.01 Abbreviations..... 5

101.06 Bidder 5

101.06a Board..... 5

101.12a City. 5

101.12b City Engineer..... 5

101.16 Contract..... 5

101.18 Contract Modification Order..... 5

101.21 Contract Time. 5

101.22 Contractor..... 5

101.27 Department..... 6

101.28 Engineer 6

101.28a Engineering Manager. 6

101.31 Force Account Work. 6

101.31a Full Time Inspection: 6

101.33 Holidays..... 6

101.34a Inspection, Full Time 6

101.34b Inspection, Part Time: 6

101.36 Laboratory 6

104.40a Part Time Inspection 6

101.42 Planned Force Account. 6

101.43 Plans 6

101.46 Project 6

101.47 Project Engineer..... 6

101.51 Proposal Form..... 6

101.52 Proposal Guaranty 6

101.63 Shop Drawings 7

101.66 Special Provisions 7

101.67 Specifications 7

101.84 Work 7

City of Grand Junction, Colorado
Standard Specifications for Road and Bridge Construction
Table of Contents

SECTIONS 102 THROUGH 109.....	8
SECTION 202 - REMOVAL OF STRUCTURES AND OBSTRUCTIONS ...	9
202.02	General..... 9
202.07	Pavements, Sidewalks, Curbs..... 9
202.09	Removal of Asphalt Mat (Planing)..... 10
202.11	Method of Measurement. 10
202.12	Basis of Payment. 10
SECTION 203 - EXCAVATION AND EMBANKMENT.....	11
203.01	General..... 11
203.14	Basis of Payment. 11
SECTION 206 - EXCAVATION AND BACKFILL FOR STRUCTURES....	12
206.02 (a)	Structural Backfill..... 12
206.03	Structure Excavation and Structure Backfill. 12
206.06	Method of Measurement. 13
SECTION 207 - TOPSOIL	14
207.02	Materials..... 14
SECTION 208 – EROSION CONTROL.....	15
208.05	Construction of Erosion Control Measures..... 15
208.08	Basis of Payment 16
SECTION 209 – WATERING AND DUST PALLIATIVES.....	17
209.05	Dust Palliative..... 17
209.07	Method Of Measurement..... 17
209.08	Basis Of Payment..... 17
SECTION 210 - RESET STRUCTURES	18
210.10	Adjust Structures. 18
210.11.1	Landscape Appurtenances..... 18
210.11.2	Sprinkler Systems..... 18
210.12	Method of Measurement 19
210.13	Basis of Payment 19
SECTION 212 - SEEDING, FERTILIZER AND SODDING.....	20
212.02	Seed, Fertilizer and Sod..... 20
212.05	Sodding 20
SECTION 304 - AGGREGATE BASE COURSE	22
304.01	Description 22
304.02	Aggregate..... 22

City of Grand Junction, Colorado
Standard Specifications for Road and Bridge Construction
Table of Contents

304.07	Method Of Measurement.....	23
304.08	Basis of Payment.	23
SECTION 306 - RECONDITIONING		24
306.02	Construction Requirements:.....	24
306.04	Basis of Payment.	24
SECTION 401 – HOT MIX ASPHALT PAVEMENTS - GENERAL		25
401.01	Description	25
401.02	Materials.....	26
401.02.1	Aggregates.....	26
TABLE 401-1	Aggregate Properties.....	26
401.02.2	Mineral Filler.....	26
401.02.3	Asphalt Cement.....	26
401.02.4	Reclaimed Material.....	27
401.02.5	Preliminary Material Acceptance	27
401.03	Composition	28
401.03.1	Composition of Mixture.....	28
401.03.2	Job Mix Formula.....	28
TABLE 401-2	Design Criteria.....	29
TABLE 401-3	Void in Mineral Aggregate (VMA).....	30
TABLE 401-4	Aggregate Gradation for HMA Pavement.....	31
401.03.3	Testing Laboratory.....	31
401.04	Construction Methods	31
401.04.1	Weather Limitations.....	31
TABLE 401-5	Placement Temperature Limitations.....	32
401.04.3	Hauling Equipment	32
401.04.4	HMA Pavers	32
401.04.5	Rollers	33
401.04.6	Preparation of HMA Material	33
401.04.7	Preparation of Mineral Aggregate.....	33
401.04.8	Preparation of HMA.....	33
401.04.9	Preparation of the Underlying Surface	34
401.04.10	Transporting, Placing and Finishing	34
401.04.11	Compaction of Mixture.....	34
401.04.12	Joints	35
401.04.13	Lift Thickness.....	35
401.04.14	HMA Patching.....	35
401.05	Material Acceptance.....	36
401.05.1	Acceptance Testing	36
401.05.2	Acceptance Criteria	37
TABLE 401-6	Acceptance Limits – Air Voids, VMA, Density	38
401.05.3	Re-sampling Pavement	39
401.05.4	Leveling Course.....	39
401.06	Contractor Quality Control.....	39
401.06.1	General.....	39
401.06.2	Testing Laboratory.....	40
401.06.3	Quality Control Testing.....	40

City of Grand Junction, Colorado
Standard Specifications for Road and Bridge Construction
Table of Contents

401.06.4	Sampling.....	41
401.06.5	Control Charts	41
	TABLE 401-7 Control Limits for Individual Measurements	42
401.07	Method of Measurement	42
401.08	Basis of Payment	42
	TABLE 401-8 Formulae for Calculating Pay Factor	43
401.09	Private Development -- Quality Assurance and Acceptance.....	43
401.09.1	Job Mix	43
401.09.2	Sampling and Testing.....	43
	TABLE 401-9 Acceptance Testing Schedule.....	44
401.09.3	Laboratory and Testing Requirements	44
401.09.4	Cost Reduction Fee (less than three tests).	45
401.09.5	Cost Reduction Fee (three or more tests).	46
SECTION 403 - HOT MIX ASPHALT		47
SECTION 405 – HEATING AND SCARIFING TREATMENT		47
405.03	Seamless Patching with Infrared Heating Process.....	47
405.04	Method of Measurement	47
405.05	Basis of Payment	47
SECTION 407 - PRIME COAT, TACK COAT AND REJUVENATING AGENT		49
407.02	Bituminous Material.....	49
407.07	Application of Bituminous Material.	49
SECTION 412 - PORTLAND CEMENT CONCRETE PAVEMENT.....		50
412.03	Classification.	50
412.17	Surface Smoothness Test.....	50
SECTION 420 - GEOSYNTHETICS		51
420.02	Materials.....	51
420.10	Basis of Payment	51
SECTION 504 - CRIBBING		52
504.01	Description.	52
504.02	Materials.....	52
504.03	Construction Requirements.....	53
504.04	Method of Measurement.	55
504.05	Basis of Payment.	55
SECTION 601 - STRUCTURAL CONCRETE		56
601.03	Materials.....	56
601.07	Mixing.....	56
601.17	Acceptance and Pay Factors.....	56

City of Grand Junction, Colorado
Standard Specifications for Road and Bridge Construction
Table of Contents

SECTION 602 - REINFORCING STEEL	57
602.08 Basis of Payment	57
SECTION 603 - CULVERTS AND SEWERS	58
SECTION 604 - MANHOLES, INLETS, AND METER VAULTS	59
SECTION 608 - CURBS, GUTTERS, SIDEWALKS AND TRAILS.....	60
608.01 Description.	60
608.02 Materials.....	60
608.03 Concrete Curb, Gutter, Sidewalks and Trails.....	61
608.04 Bituminous Sidewalks and Bikeways.	66
608.05 Method of Measurement.	67
608.06 Basis of Payment.	67
SECTION 609 - CURB AND GUTTER	69
SECTION 610 – MEDIAN COVER MATERIAL.....	70
SECTION 619 - WATER LINES	72
SECTION 625 - CONSTRUCTION SURVEYING	73
625.01 Description.	73
625.02 Materials and Equipment.....	73
625.03 Construction Requirements.....	73
625.04 Contractor Surveying.....	73
625.05 Staking.	73
625.06 Accuracy and Tolerances.....	74
625.07 Responsibility and Inspection.....	74
625.08 Reset Controls and Stakes.....	74
625.09 Changes.....	74
625.10 Pay Quantity Measurements.....	74
625.11 Survey Records.....	74
625.11a As-Built Drawings.....	74
625.12 Method of Measurement.....	75
625.13 Basis of Payment.....	75
SECTION 626 - MOBILIZATION	76
SECTION 629 - SURVEY MONUMENTATION.....	77
629.01 Description.....	77
629.02 Materials.....	77
629.03 General.....	77
629.04 Location Monuments.....	78
629.05 Preserving and Referencing Monuments.....	78

City of Grand Junction, Colorado
Standard Specifications for Road and Bridge Construction
Table of Contents

629.06	Installing Monuments.	78
629.07	Monument Box.	79
629.09	Basis of Payment.	79
SECTION 630 - CONSTRUCTION ZONE TRAFFIC CONTROL.....		80
630.09	Traffic Control Plan.....	80
630.14	Method of Measurement.	81
630.15	Basis of Payment.	81
SECTION 703 - AGGREGATES		83
703.07	Bed Course Material.....	83
SECTION 705 – JOINT, WATERPROOFING AND BEARING MATERIALS		84
705.01	Joint Fillers.	84
SECTION 711 - CONCRETE CURING MATERIALS AND ADMIXTURES		85
711.01	Curing Materials.	85
711.03	Chemical Admixtures and Color Additive.	85

CITY OF GRAND JUNCTION, COLORADO
DEPARTMENT OF PUBLIC WORKS AND PLANNING
ENGINEERING DIVISION

**STANDARD SPECIFICATIONS FOR
ROAD AND BRIDGE CONSTRUCTION**

GENERAL

Section 101 and Sections 200 through 717 of the **Standard Specifications for Road and Bridge Construction**, 2005 edition, published by the Colorado Department of Transportation (CDOT), State of Colorado, as re-emphasized, supplemented or amended by the State and by these specifications shall govern all road and bridge construction work within the public right-of-way and in other areas of City jurisdiction or ownership. In cases of any conflicts of meaning between the CDOT specifications and other specifications, the supplements and amendments listed below or in the project *Special Provisions* shall govern. The *Special Provisions* (if any) contained in the *Bid Documents* shall have precedence over all other specifications.

When reference is made to ASTM, AWWA, AASHTO, or other specifications or methods, it shall be understood to mean the latest edition or revision of said specification as amended and issued at the time of the *Invitation to Bid*.

The Method of Measurement and Basis of Payment for the items of work specified herein and in the CDOT specifications apply only to City projects and are not required to be used on projects which are administered and paid for by private developers or other agencies.

QUALITY CONTROL AND QUALITY ASSURANCE

QUALITY CONTROL: The Contractor is responsible for quality control of all work performed and shall implement whatever procedures, methods, testing, surveying, and supervision that is required in order to insure that the Work conforms to the *Plans* and *Specifications*. Quality control for hot bituminous pavement shall be in accordance with Section 401.06 of these specifications.

QUALITY ASSURANCE: The developer, owner or entity responsible for administering the construction of public facilities shall provide a quality assurance program. This program shall include systematic inspection and testing of the work and materials during construction to assure the owner and the City that the Contractor is providing work that is in conformance with the City-approved plans and specifications. Minimum quality assurance testing requirements for road construction shall be as shown in Table 1.

Initial testing shall be performed at the beginning of each construction phase in order to identify and correct any non-compliance work.

A minimum of one test will be required for any portion of material less than that shown in the "Minimum Test Frequency" column on Table 1, unless otherwise approved by the City Quality Assurance Technician. The City will perform random testing to determine if the materials meet specifications.

All failing tests shall be re-tested after the material has been reworked, modified or adjusted by the Contractor. The Contractor will be required to remove and replace any work or materials that do not meet test requirements or specifications. All materials installed in the work shall be inspected, tested, and approved by the Construction Inspector before proceeding to the next phase of construction.

FINAL INSPECTION AND ACCEPTANCE: The acceptance of all road and bridge improvements by the City will be based on the following:

- 1) Submittal of results of all required quality control and quality assurance tests certified by the Engineer or a qualified independent laboratory.
- 2) Submittal of a copy of the daily inspection reports prepared by the Engineer or his representative.
- 3) Passing a final inspection of the work by the City Project Engineer or his representative.
- 4) **Non-City Managed Projects:** Submittal of "As-Built" construction drawings in accordance with the *Grand Junction Submittal Standards for Improvements and Developments Manual*.
- 5) **City Managed Projects:** The Contractor shall submit a set of red-lined "As-Built" drawings in accordance with Section 54 of the General Contract Conditions. All changes shall be neatly printed or marked on a full size blue-line copy of the plan set.

City of Grand Junction, Colorado
Standard Specifications for Road and Bridge Construction

**TABLE 1 – REQUIRED QUALITY ASSURANCE (QA) AND
QUALITY CONTROL (QC) TESTING**

TEST REQUIRED	TEST PROCEDURE / REQUIREMENTS	TEST FREQUENCY	
		PART TIME INSPECTION	FULL TIME INSPECTION
Compaction of subgrade and embankment under curbs, gutters, sidewalks and trails	AASHTO T 99 ^{*3} and T 310 95 % min. relative compaction	1 per 200 LF	1 per 400 LF
Compaction of subgrade and embankment under roadways.	AASHTO T 99 ^{*3} and T 310 95% min. relative compaction	1 per 400 SY	1 per 600 SY
Compaction of aggregate base course under concrete curbs, gutters and/or sidewalks	AASHTO T 180 & T 310 95% min. relative compaction	1 per 200 LF	1 per 400 LF
Compaction of aggregate base course under concrete fillets and drain pans	AASHTO T 180 & T 310 95% min. relative compaction	1 per fillet; 1 per per 50 LF pan	1 per fillet; 1 per 100 LF pan
Compaction of aggregate base course materials under roadways	AASHTO T 180 & T 310 95% min. relative compaction	1 per 400 SY	1 per 600 SY
Compaction of Structure Backfill	AASHTO T 180 & T 310 95% min. relative compaction	1 for each 2 ft. of vertical depth per per 100 LF of structure perimeter	
Gradation aggregate base course (QC)	CDOT Table 703-2	1 per 5000 Ton	1 per 5000 Ton
<u>Hot Mix Asphalt</u> ^{*1}			
Asphalt Content (QC)	CP42-95 method A or E, or CPL 5120	1 per 1000 Ton 1 per day min	1 per 1000 Ton 1 per Day min
Gradation of aggregate (QC)	CP31-95	1 per 1000 Ton	1 per 1000 Ton
Air Voids (Pa)	Table 401-3 ^{*2} AASHTO T 269 2.8% to 5.2%	1 per 1000 Ton	1 per 1000 Ton
Voids in Mineral Aggregate (VMA)	CP 48-95 Table 401-2 ^{*2}	1 per 1000 Ton	1 per 1000 Ton
Percent Relative Compaction	CP51 & 81, 92% to 96%	1 per 500 SY	1 per 800 SY
<u>Portland Cement Concrete</u> ^{*1}			
Compressive Strength (4 cylinders per set)	AASHTO T 22 & T 23 see Section 601.02	1 set/100 CY	1 set/100 CY
Air Content	AASHTO T 152, 6% ± 1.5%	1 per 100 CY	1 per 100 CY
Slump	AASHTO T 119, 4" max.	1 per 100 CY	1 per 100 CY

^{*1} The job mix formulas for hot mix asphalt and Portland cement concrete shall be submitted in typed form by the Contractor to the Engineer at least 10 days prior to the start of paving or concrete placement.

^{*2} See revised tables in City Specifications

^{*3} Compaction of embankment and subgrade soils shall be determined in accordance with AASHTO T 180 when specified, directed or approved by the Engineer in writing. The minimum percent relative compaction shall be in accordance with Subsection 203.07 of the CDOT Standard Specifications unless otherwise specified.

Laboratory and Field Testing Requirements. All sampling and testing shall be performed by qualified technicians using the proper equipment as required by each test procedure.

Hot Mix Asphalt. Personnel performing sampling and testing of aggregates for hot mix asphalt (HMA) or bituminous mixtures shall possess the appropriate CAPA (LabCat) certification or combination of certifications for all sampling and testing performed. CAPA certifications include: A - Laydown, B - Asphalt Plant Materials Control, C - Mixture Volumetrics and Stability and E - Aggregates.

Soil and Aggregates. Technicians performing testing of soils or aggregates for road base or embankment construction shall be NICET Level II, or WAQTC certified.

Portland Cement Concrete. Personnel conducting field-testing of concrete must be American Concrete Institute (ACI) certified as a Concrete Field Testing Technician - Grade I. Field-testing of concrete includes slump, temperature, air content, wet unit weight and the making of compressive strength cylinders.

Personnel conducting compressive strength tests must be certified as ACI Laboratory Testing Technician - Grade I or ACI Concrete Strength Testing Technician.

Hand finishing concrete will be permitted only when performed under the direct supervision of a craftsman holding the following certificate: ACI Concrete Flatwork Finisher and Technician (ACICFFT) or other Flatwork Finisher certification program approved by the City Engineering Manager.

SECTION 101 - DEFINITIONS AND TERMS

101.01 Abbreviations. Add the following abbreviations:

CAPA	Colorado Asphalt Pavement Association
HMA	Hot Mix Asphalt
SSFRB	City of Grand Junction Standard Specifications for Road and Bridge Construction (latest edition)
SSFUU	City of Grand Junction Standard Specifications for Construction of Underground Utilities – Waterlines, Sanitary Sewers, Storm Drains, Under-drains and Irrigation Systems (latest edition)
SSID	Submittal Standards for Improvements and Development (latest edition)
TEDS	Transportation Engineering Design Standards (latest edition)
WAQCT	Western Alliance for Quality Transportation Construction
QAT	Quality Assurance Technician

ADD OR REVISE DEFINITIONS AS FOLLOWS:

101.06 Bidder. In the CDOT definition REPLACE "Department" WITH "City".

101.06a Board. Colorado State Board of Registration for Professional Engineers and Professional Land Surveyors.

101.12a City. SEE DEFINITIONS IN THE CITY *GENERAL CONTRACT CONDITIONS*.

101.12b City Engineer. TITLE HAS BEEN CHANGED TO Engineering Manager

101.16 Contract. DELETE IN ITS ENTIRETY. SEE DEFINITION IN THE CITY *GENERAL CONTRACT CONDITIONS*.

101.18 Contract Modification Order. DELETE IN ITS ENTIRETY.

101.21 Contract Time. DELETE IN ITS ENTIRETY. SEE DEFINITION IN THE CITY *GENERAL CONTRACT CONDITIONS*.

101.22 Contractor. DELETE IN ITS ENTIRETY. SEE DEFINITION IN THE CITY *GENERAL CONTRACT CONDITIONS*.

City of Grand Junction, Colorado
Standard Specifications for Road and Bridge Construction

- 101.27** **Department.** REVISE 101.26 TO READ: Department of Public Works and Planning, City of Grand Junction, Colorado.
- 101.28** **Engineer.** The Project Engineer, who may be a City employee or hired consultant who has been appointed or authorized by the City to oversee the technical aspects of the work and to administer the Contract on behalf of the City. The term “Engineer” may also apply to a Professional Engineer hired by a developer to design and/or administer the construction of public infrastructure in accordance with a development approved by or contracted for/or with the City.
- 101.28a** **Engineering Manager.** Engineer employed by the City, responsible for all construction contract decisions.
- 101.31** **Force Account Work.** REVISE 101.30 TO READ: Work paid for on the basis of actual costs plus approved additives, in accordance with the General Contract Conditions.
- 101.31a** **Full Time Inspection:** SEE 103.4a
- 101.33** **Holidays.** DELETE IN ITS ENTIRETY. SEE DEFINITION IN THE CITY *GENERAL CONTRACT CONDITIONS*.
- 101.34a** **Inspection, Full Time:** Where the Engineer or representative of the Engineer is on the project for continuous observation, documentation and/or testing during the hours of construction activity.
- 101.34b** **Inspection, Part Time:** Where the Engineer or representative of the Engineer is on the project for periodic observation, documentation, and/or testing of the project construction.
- 101.36** **Laboratory.** DELETE IN ITS ENTIRETY. SEE DEFINITION IN THE CITY *GENERAL CONTRACT CONDITIONS*.
- 104.40a** **Part Time Inspection:** SEE 103.4b
- 101.42** **Planned Force Account.** DELETE IN ITS ENTIRETY.
- 101.43** **Plans.** DELETE IN ITS ENTIRETY. SEE DEFINITION IN THE CITY *GENERAL CONTRACT CONDITIONS*.
- 101.46** **Project.** SEE DEFINITION IN THE CITY *GENERAL CONTRACT CONDITIONS*.
- 101.47** **Project Engineer.** IN THE CDOT DEFINITION, REPLACE "Chief Engineer's" WITH "City's". Replace “CDOT” with “City”. Replace “Resident” with “City”.
- 101.51** **Proposal Form.** REVISE 101.50 TO READ: The documents furnished by the City on which the offer of a bidder is submitted. Also referred to as Bid Proposal or Bid Form.
- 101.52** **Proposal Guaranty.** REVISE 101.51 TO READ: Bid Guaranty as defined in the City *General Contract Conditions*.

City of Grand Junction, Colorado
Standard Specifications for Road and Bridge Construction

- 101.63** **Shop Drawings.** DELETE IN ITS ENTIRETY. SEE DEFINITION IN THE CITY *GENERAL CONTRACT CONDITIONS*.
- 101.66** **Special Provisions.** INCLUDE THE DEFINITION IN THE CITY *GENERAL CONTRACT CONDITIONS*.
- 101.67** **Specifications.** DELETE IN ITS ENTIRETY. SEE DEFINITION IN THE CITY *GENERAL CONTRACT CONDITIONS*.
- 101.84** **Work.** DELETE IN ITS ENTIRETY. SEE DEFINITION IN THE CITY *GENERAL CONTRACT CONDITIONS*.

SECTIONS 102 THROUGH 109

Sections 102 through 109 are deleted and replaced with the City of Grand Junction, General Contract Conditions.

SECTION 202 - REMOVAL OF STRUCTURES AND OBSTRUCTIONS

202.02 General.

REVISE THE SIXTH PARAGRAPH TO READ AS FOLLOWS:

Concrete pavement shall be cut vertically along pre-marked lines. The depth of the saw cut shall be the full depth of the concrete section unless otherwise specified or approved.

202.07 Pavements, Sidewalks, Curbs.

ADD THE FOLLOWING:

Materials Contaminated with Radioactive Mill Tailings. In the 1940's, 50's and 60's radioactive uranium mill tailings were used in the Grand Junction area as bedding and backfill material for construction of pipelines, building foundations, parking lots, sidewalks and roadways. When radioactive mill tailings are found in, under or adjacent to pipe, asphalt pavement, concrete or other materials designated for removal, the Contractor shall contact the Colorado Department of Public Health and Environment (CDPHE), Radiation and Hazardous Waste Division (phone no. (970) 248-7164) for material characterization. If the radioactive level of the contaminated material exceeds the threshold level, as determined by the CDPHE representative, the material shall be either decontaminated in accordance with CDPHE requirements, or transported to the designated radioactive materials containment facility located at the City Shops, 333 West Avenue for disposal. Prior to loading, all concrete, pipe and other materials contaminated with mill tailings shall be broken into pieces, which are no greater than six feet in any dimension. The Contractor shall take all necessary precautions to separate uncontaminated materials from those that have been contaminated with mill tailings.

Prior to transporting radioactive mill tailings or other materials contaminated with mill tailings, the transporter shall make arrangements with the City Construction Inspector or call the City Construction Engineering office at (970) 244-1453 to make arrangements for opening and closing the radioactive materials containment facility.

Trucks used to haul uranium mill tailings and other radioactive materials shall be prepared to prevent spillage. Tailgate diapers shall be used on truck tailgates that are not leak proof.. Tailgate diapers shall be 6-mil or thicker polyethylene and shall cover the entire tailgate and 4 feet back on the sides and bottom of the bed. Each load shall be covered with a bedcover made of canvas, or other approved material, and shall be securely tied down. After dumping the material at the designated containment site, the bed of each truck shall swept or washed out to remove all remaining radioactive material.

Each truck driver hauling radioactive mill tailings or materials contaminated with mill tailings shall have in his possession a document listing the name and address of the transporter, a description of the radioactive materials being transported, the address or location where the radioactive materials came from and the address of the destination (City Shops, 333 West Avenue).

202.09 Removal of Asphalt Mat (Planing)

ADD THE FOLLOWING:

Asphalt pavement designated to be cut for removal, shall be cut along pre-marked lines by planing (milling), wheel cutting or with a jackhammer unless otherwise specified or approved by the Engineer. Where saw cutting is approved, the saw cut face shall be roughened with hand tools or other approved method prior to placing new pavement against it.

Where concrete pavement is to be placed against existing asphalt pavement, the edge of the pavement shall be saw cut along straight pre-marked lines.

Cut faces of concrete and asphalt pavement shall be protected from damage by backfilling with road base or other approved method until the adjacent pavement has been replaced.

Asphalt pavement designated for removal by planing (milling) shall remain property of the City and shall be transported to a designated storage area at the City Shops located at 333 West Avenue, unless otherwise specified or approved. All other asphalt pavement designated for removal shall be removed from the job site and disposed of by the Contractor, unless otherwise specified.

202.11 Method of Measurement.

ADD THE FOLLOWING PARAGRAPHS:

Unless otherwise provided for in the Bid Schedule, cutting asphalt pavement and saw cutting concrete for removal will not be measured or paid for separately, but shall be included in the Work. When paid for separately, cutting asphalt and concrete pavements will be measured by the linear foot.

Decontamination of radioactive pavements, pipe and other materials for disposal will be considered extra work unless provided for in the Bid Schedule. Such extra work must be authorized in advance by a Field Order or Change Order. The haul and disposal of radioactive pavements, pipe and other materials, which cannot be decontaminated, as determined by the Engineer, will be measured and paid for in accordance with Subsection 203.13.

202.12 Basis of Payment.

ADD THE FOLLOWING PAY ITEMS TO THE TABLE:

Pay Item	Pay Unit
Saw Cut Concrete	Linear Foot
Cut Asphalt Pavement	Linear Foot

SECTION 203 - EXCAVATION AND EMBANKMENT

203.01 General.

ADD THE FOLLOWING:

Radioactive uranium mill tailings and other radioactive materials found in project excavations shall be replaced in the backfill at the same location from which it was removed unless otherwise specified or directed by the Engineer. Radioactive materials shall be placed below the roadway subgrade elevation or at least one foot below finished grade, whichever is greater.

Excess excavated materials and/or materials that are unsuitable for placement in the backfill, which exceed the radioactive threshold as determined by CDPHE, shall be hauled to the designated containment facility located in the City Shops at 333 West Avenue. Loading and hauling of radioactive materials shall be in accordance with Subsection 202.07. The Contractor shall not remove radioactive materials beyond the depths and limits of excavation shown on the plans unless otherwise approved by the Engineer.

When radioactive mill tailings, soil or other contaminated materials are replaced in the backfill, or embankment, the Contractor shall fill out a form, furnished by the Inspector, describing the horizontal locations and depths at which the radioactive materials were placed. Copies of this form shall be provided to the Inspector and to CDPHE at 222 S. 6th St., Grand Junction, CO 81501.

203.14 Basis of Payment.

ADD THE FOLLOWING:

Unless otherwise specified or provided for in the Bid Schedule, blading, dozing, stripping and proof rolling will not be measured or paid for separately but shall be included in the work.

The excavation and replacement of radioactive mill tailings in project embankments or backfill will be measured and paid for under the earthwork items listed in the Bid Schedule. No separate or additional payment will be made for the excavating, handling, stockpiling, placing and compacting radioactive materials with moisture and density control.

When authorized by the Engineer, the loading and hauling of radioactive mill tailings and/or materials contaminated with mill tailings to the City's designated containment facility will be measured and paid for separately. The quantity of radioactive material to be paid for shall be determined by measuring the volume of material loaded, transported and deposited in the designated containment facility at the City Shops. The Contractor and the Engineer shall agree on the method of measurement and the quantity to be paid for.

Payment will be made under:

Pay Item	Pay Unit
Disposal of Radioactive Materials	Cubic Yard

SECTION 206 - EXCAVATION AND BACKFILL FOR STRUCTURES

206.02 (a) Structural Backfill.

ADD THE FOLLOWING:

Structure backfill (flow-fill) may be made from different ingredients and/or at different proportions than those specified in the CDOT Standard Specifications when approved by the Engineer in writing. The Engineer may require that a sample of the proposed flow-fill mix be prepared, tested and/or placed in the backfill to demonstrate its performance prior to approval of the mix.

206.03 Structure Excavation and Structure Backfill.

ADD THE FOLLOWING TO THE THIRD PARAGRAPH:

Structure backfill shall be compacted with hand operated mechanical equipment unless otherwise approved by the Engineer. The un-compacted layer thickness may be increased from six (6) to eight (8) inches when the Contractor is able to achieve the required density within 24 inches of the structure.

ADD THE FOLLOWING AT THE END OF SECTION 206.03

Structure backfill (flow-fill) is recommended for use as backfill when the roadway must be quickly reopened to traffic. It may be used to backfill utility trenches, manholes and other structures and excavations. Flow-fill shall not be placed around the bottom half of pipes or structures that could be displaced or damaged by the buoyant forces of the flow-fill. Bleed water shall be drained off or otherwise removed from the surface before additional layers of backfill are placed.

Excavation and backfill for the installation of all pipe, manholes, valves, vaults and other structures and appurtenances shall be in accordance with the City's *Standard Specifications for Construction of Underground Utilities*.

Radioactive Materials. Radioactive uranium mill tailings have been used in the Grand Junction area as bedding and backfill material for underground utilities. If mill tailings are encountered in the excavation for the installation or removal of pipes or structures, the Contractor shall contact the CDPHE, Radiation and Hazardous Waste Division at 248-7164 for material characterization. If the level of radioactivity exceeds the threshold as determined by the CDPHE or its agent the radioactive material shall be handled as follows:

- (a) If possible, leave the mill tailings in place where they are found.
- (b) If radioactive mill tailings must be excavated for the installation or removal of a structure or pipe, they shall be replaced in the backfill in the area where they were removed unless the Construction Inspector determines that the material is unsuitable for use in the backfill.
- (c) If excavated mill tailings are unsuitable for use in the backfill, the Contractor shall dispose of the radioactive material in accordance with subsections 202.07 and 203.01 of

these specifications. The Contractor shall take all necessary precautions to separate radioactive material from non-contaminated materials prior to disposal.

206.06 Method of Measurement.

ADD THE FOLLOWING TO THE BEGINNING OF THE FIRST PARAGRAPH:

Unless otherwise provided for in the Bid Schedule, structure excavation, structure backfill, bed course material, filter material, structure backfill (flow-fill), and haul and disposal of excess or unsuitable excavated material will not will not be measured or paid for separately, but shall be included in the Work.

ADD THE FOLLOWING PARAGRAPH:

The replacement of radioactive uranium mill tailings in structure backfill will not be measured or paid for separately but shall be included in the work. Authorized loading, haul and disposal of excess or unsuitable radioactive material at the City containment site at located at 333 West Avenue will be measured and paid for in accordance with subsection 203.14 of these specifications.

SECTION 207 - TOPSOIL

207.02 Materials.

REPLACE THE FIRST PARAGRAPH WITH THE FOLLOWING:

Topsoil shall consist of free-draining friable sandy loam; free of roots, rocks larger than 3/8-inch, subsoil, debris, brush weeds, heavy clay, hard clods, toxic substances or other material which would be detrimental to its use on the project; have an electro-conductivity range of 0 to 4 millimhos/cm and contain a minimum of 4% and maximum of 25% organic matter with a limit of decaying matter to 2% of the total volume. These requirements shall be certified by an approved independent laboratory unless the topsoil is from a pre-approved source.

207.04 Method of Measurement.

REVISE AS FOLLOWS:

Topsoil and wetland topsoil salvaged from the roadway or other project excavations and placed in stockpiles or windrows to be reused on the project will be measured or paid for as Topsoil or Wetland Topsoil. No separate or additional payment will be made for stockpiling or windrowing topsoil.

SECTION 208 – EROSION CONTROL

208.02 (l) *Stabilized construction Entrance.* ADD THE FOLLOWING:

Aggregate for the stabilized construction entrance shall be crushed rock or crushed concrete meeting the gradation of this subsection unless otherwise specified or approved by the Engineer.

208.05 Construction of Erosion Control Measures

IN SUBSECTION (j) ADD THE FOLLOWING PARAGRAPHS AFTER THE 2ND PARAGRAPH:

Storm drain inlet protection shall be provided where runoff from construction sites enters conveyance system structures such as drain inlets, drop inlets and curb inlets. Inlet protection devices are for drainage areas of one acre or less. Runoff from areas larger than one acre shall be routed through approved sediment trapping or settling facilities upstream of the inlet.

Storm drain inlet protection devices shall be installed before the contributing drainage area is disturbed. The devices shall remain in place and be maintained until the disturbed area is stabilized.

Inlet protection shall be inspected weekly and within 24 hours after every precipitation event by the Contractor's Erosion Control Supervisor. Sediment deposits shall be removed and the inlet protection device restored to its original condition when sediment has accumulated to ½ of the capacity of the device, or when the device is no longer functioning as designed. The method of depositing and stabilizing, or disposal of removed sediment shall be approved by the Engineer.

Inlet protection devices shall be removed once the contributing area is stabilized with appropriate vegetation or impervious surface.

IN SUBSECTION (n), REPLACE THE FIRST PARAGRAPH WITH THE FOLLOWING:

Concrete Washout Structure Design. At least 10 days prior to start of placing concrete, the Contractor shall submit in writing a *method* statement outlining the design, site location and installation of a facility that will contain washout from concrete placement operations. Work on this structure shall not begin until written acceptance is provided by the Engineer.

ADD THE FOLLOWING TO SUBSECTION (o):

(o)

Surface water shall be prevented from passing through the tracking pads. Flows shall be diverted around or conveyed under the pads by using a variety of practices, such as culverts, water bars or diversion ditches.

Tracking pads shall be inspected weekly and within 24 hours after every precipitation event by the Contractor's Erosion Control Supervisor. The contractor shall maintain the

stabilized construction entrances during the entire time that they are in use. Aggregate shall be added or replaced as needed. If conditions on the site are such that the mud and sediment are not removed from vehicle tires by the tracking pad, then tires shall be washed utilizing pressurized water before entering a public road. Water from tire washing operations shall be collected and contained on site unless otherwise approved.

Any sediment or mud tracked onto a public or private road shall be immediately removed by mechanical sweeping or other approved method.

Stabilized construction entrances shall be removed at the completion of the project unless otherwise directed by the Engineer.

208.08 Basis of Payment

REPLACE THE FIRST PARAGRAPH WITH THE FOLLOWING:

Work to furnish, install, maintain, remove and dispose of erosion and sediment control features specified in the contract may be paid for at the lump sum contract price for erosion control (complete in place) or at the contract unit price for each of the items listed in the bid scheduled.

ADD THE FOLLOWING TO THE LIST OF PAY ITEMS.

Pay Item	Pay Unit
Erosion Control (complete in place)	Lump Sum

The lump sum price for Erosion Control (complete in place) shall be full compensation for the Erosion Control Supervisor and all materials, labor and equipment required to furnish, install, maintain, remove and dispose of erosion and sediment control features and Best Management Practices (BMPs) in accordance with the Storm Water Management Plan (SWMP), State and local permits, and the contract documents.

SECTION 209 – WATERING AND DUST PALLIATIVES

209.05 Dust Palliative.

REPLACE THE FIRST AND SECOND PARAGRAPHS AS FOLLOWS:

The Contractor shall furnish and apply a dust palliative on portions of the roadway, haul roads and other locations as necessary or as directed to prevent air borne dust. This shall include prevention of dust generated from the Contractors operations and from windy weather conditions. Dust abatement shall be provided, as needed, throughout the construction period included nights, weekends and holidays.

Dust palliative may consist of water, magnesium chloride or approved substance. Application of dust palliative shall be done with acceptable sprinkling equipment at an appropriate rate as approved by the Engineer.

209.07 Method Of Measurement.

DELETE AND REPLACE WITH THE FOLLOWING:

The quantity of water required for all items of work will not be measured. Magnesium chloride dust palliative will not be measured but will be paid for under Dust Abatement.

209.08 Basis Of Payment.

DELETE AND REPLACE WITH THE FOLLOWING:

The furnishing and application of water for moisture and density control, landscape watering and pre-wetting excavation areas will not be measured or paid for separately but shall be included in the work. The furnishing and application of water, magnesium chloride or other approved dust palliative will be paid for under:

Pay Item	Pay Unit
Dust Abatement	Lump Sum, Day

Dust abatement required beyond the specified contract time will not be paid for unless authorized in advance by a Work Change Authorization or Change Order.

SECTION 210 - RESET STRUCTURES

210.10 Adjust Structure.

CHANGE THE THIRD SENTENCE OF THE PARAGRAPH AS FOLLOWS:

Structures in the traveled roadway, including manhole covers, shall be adjusted to a tolerance of 1/8 to 1/4 inch below the surface of the roadway.

ADD THE FOLLOWING:

Manhole rings and covers shall be temporarily replaced with a round steel plate prior to paving with asphalt. Within 10 days after paving, the asphalt shall be neatly cut around the steel plate and asphalt and steel plate removed. The manhole ring and cover shall then be reset to match the pavement surface. Concrete grade rings shall be dry stacked to within two (2) inches of the bottom of the cast iron ring elevation. The cast iron ring shall be set to the final pitch and elevation with shims or other approved method. The space between the top grade ring and the cast iron manhole ring shall be filled with QUIKRETE® Rapid Road Repair (No. 1242) or an approved equal.

The annular space between the manhole ring and the roadway pavement shall be patched by placing and compacting hot mix asphalt (in 2 inch maximum layers) to the same thickness as the adjacent pavement.

For asphalt overlays, a single cast iron grade ring may be used to adjust the elevation of a manhole ring and cover only when the cross slope of the pavement surface does not change. Only one cast iron grade ring will be allowed on each manhole. The cast iron ring shall be one piece and shall be the same height as the overlay thickness. The grade adjustment ring shall be attached to the manhole ring with set screws.

Water valve boxes shall be checked for proper centering over the valve-operating nut prior to paving. Valve boxes shall be adjusted to grade during the paving operation.

ADD THE FOLLOWING AFTER SUBSECTION 210.11

210.11.1 Landscape Appurtenances

Landscaping appurtenances shall include, but not be limited to, planters, decorative rock, tree bark, wooden and masonry borders and ornamental objects. When designated to be reset, landscape appurtenances shall be removed, stockpiled during construction and reset as shown on the plans or as directed. When designated for removal, landscape appurtenances shall be disposed of by the Contractor, unless otherwise specified or directed.

210.11.2 Sprinkler Systems.

Where sprinklers are designated to be reset, the work shall include the temporary relocation of the sprinkler, pipe, fittings, valves and appurtenances as needed to place the sprinkler back in service during construction. When the sprinklers do not need to be in service during construction, the irrigation lines shall be plugged or capped to allow the remainder of the system to be used by the property owner. Sprinklers, pipe, fittings, valves and appurtenances removed

during construction shall be stockpiled and protected from damage. Pipe connections shall be made with new materials. Sprinkler heads, pipe and appurtenances that are damaged during removal and/or storage shall be replaced with new materials of the same or better quality at the Contractor's expense. Sprinklers, pipe, fittings and appurtenances that are not damaged by the Contractor, but are unsuitable for reuse, shall be replaced with new materials. Such materials will be either furnished by the property owner or paid for separately by the City.

210.12 Method of Measurement

ADD THE FOLLOWING:

The quantity of sprinklers to be paid for shall be the total number that are reset and approved. Resetting sprinklers to a temporary location during construction when specified in the Contract documents, will not be measured or paid for separately, but shall be included in the work.

Reset sprinklers will not be measured when paid for under Reset Sprinkler System (complete in place).

210.13 Basis of Payment

ADD THE FOLLOWING:

Payment will be made under:

Pay Item	Pay Unit
Reset Sprinkler	Each
Reset Sprinkler System (complete in place)	Lump Sum
Reset Sprinkler System (per property)	Each
Reset Landscape Appurtenance (description)	Each, Linear Foot, Square Yard, Lump Sum

SECTION 212 - SEEDING, FERTILIZER AND SODDING

MATERIALS

212.02 Seed, Fertilizer and Sod

ADD THE FOLLOWING TO PARAGRAPH (a) *SEED*:

Dryland seed mix shall be as follows unless otherwise approved by the City's Forestry Supervisor:

Description	PLS rates per acre (100%)	% of mix	PLS rate per species per acre
Crested Wheatgrass, Ephraim	6	20%	1.25
Western Wheatgrass, Arriba	16	20%	3.25
Smooth Brome, Lincoln	12	15%	2.0
Alkali Sacaton	0.5	10%	0.25
Viva Galleta Grass	12	10%	1.25
Orchard grass, Paiute	4	10 %	0.5
Perennial Ryegrass, Tetraploid	8	15%	1.25
Oats or Winter Wheat	add in	add in	3.0
Total		100	12.75
Drilled rate @ 12.75 lbs/acre			
Broadcast rate @ 25.5 lbs/acre			

ADD THE FOLLOWING TO PARAGRAPH (b) *Fertilizer*:

The application rate for fertilizer shall be 200 lb/acre for all seeding and sod installation unless otherwise approved by the Engineer.

212.05 Sodding.

ADD THE FOLLOWING TO PARAGRAPH (a) *Soil Preparation*:

Soil Preparation Adjacent to Sidewalk, Curb or Other Pavement. Before placing sod adjacent to pavement, the existing sod shall be neatly cut and removed to a line parallel to the pavement edge. The minimum width of sod to be placed adjacent to new pavement shall be 11 inches and the maximum width shall as needed to meet a maximum slope of 4 to 1, unless otherwise specified or approved by the Engineer. All voids left by the removal of forms or over-excavation shall be filled with clean topsoil to within 1½" of the finished surface elevation prior to placing sod. If no sod or plantings are to be installed, the void shall be filled with topsoil to the finished concrete or pavement elevation.

City of Grand Junction, Colorado
Standard Specifications for Road and Bridge Construction

ADD THE FOLLOWING TO PARAGRAPH (b) *Sodding*

The Contractor shall supply water used for watering sod. The Contractor shall not use water from any residence water without first obtaining permission from the resident.

Immediately after placement of sod, it shall be the Contractor's responsibility to contact and provide each resident written instructions describing how and when to water and care for the new sod. If a resident is out of town or cannot be found, the Contractor shall be responsible for watering the sod until the resident can be contacted and notified about watering the sod.

Sod shall only be installed where authorized by the Engineer or the Construction Inspector. The City will prepare a list of those properties that require sod replacement. Prior to ordering sod, the Contractor shall review locations and determine the quantity of sod required.

SECTION 304 - AGGREGATE BASE COURSE

304.01 Description

ADD THE FOLLOWING:

This work also includes subgrade stabilization when needed to replace wet or otherwise unstable ground conditions below the normal subgrade elevation. Subgrade stabilization shall include excavation of unsuitable material and the furnishing, placing and compaction of aggregate base course (class___) to the depth and limits determined by the Engineer.

304.02 Aggregate.

ADD THE FOLLOWING:

Class 3 Aggregate Base Course: Class 3 Aggregate Base Course (pit run), shall meet the following requirements:

Maximum Particle Dimension	8"
Percent passing No. 4 sieve	20% min.
Minus 200 Screen Size	20% max.
Plasticity Index (PI)	7 maximum

In addition to the above requirements, the Engineer and/or the Construction Inspector shall have the authority to determine, by visual inspection, if the material delivered to the job site contains a sufficient quantity of fine graded material to fill the voids between rocks when the material is placed and compacted. Material that is segregated or otherwise unsuitable for use in the backfill shall be removed from the job site or blended with other suitable material as directed or approved by Engineer or his representative.

Prior to placement of pit run aggregate or other material that is "too rocky to test" using standard density testing procedures, the Contractor shall prepare and submit a Construction Procedure Plan for approval by the Engineer. This plan shall describe the equipment, methods and procedures that the Contractor shall use to place and compact the material. The City may require that the contractor demonstrate the proposed procedures before approval is given. The Construction Procedure Plan shall include the following:

- (a) Source(s) of the proposed backfill material.
- (b) Equipment to be used for placement and compaction of the material:
- (c) Description of how moisture content of the material will be tested and, if necessary, adjusted.
- (d) Description of methods that will be used to place the material in the trench or excavation including the maximum lift thickness to be placed and compacted.

- (e) Description of the method of compaction including equipment to be used.

Construction Inspection. When the embankment or backfill material is too rocky to test, the City requires full time inspection and observation during the placement and compaction of the material to assure compliance with the approved Construction Procedure Plan. For non-City managed projects, the Inspector shall be NICET Level II or WAQTC certified in construction materials or highway construction and shall be employed by an independent laboratory or consulting engineering firm.

Moisture Content Monitoring. The material that is too rocky to test shall be sampled and tested for moisture content at the same frequency specified in section 103.14 for compaction testing. Samples for moisture content tests shall be randomly taken from the material being placed. The moisture content of the material shall not deviate from optimum on the dry side by more than two percentage points as determined by AASHTO T 99 or T 180 method "A". Moisture content testing shall be performed on the minus #4 fraction of the material, by the Inspector or by an independent laboratory at the owners expense.

Proof Rolling. The Engineer or Construction Inspector may require proof rolling of the compacted aggregate base course or subgrade stabilization material to test for deflection. Equipment for proof rolling shall be in accordance with Subsection 203.09. If while proof rolling, any visible deflection or rutting is observed, additional compaction, reblending or replacement of the aggregate base course may be required.

304.07 Method Of Measurement

DELETE AND REPLACE WITH THE FOLLOWING:

The furnishing, placement and compaction of aggregate base course (bed course) under concrete curbs, gutters, sidewalks, drainage pans, intersection fillets and driveway sections, and curb ramps will not be measured or paid for separately, but shall be included in the Work.

All other aggregate base course material and shoulder gravel material will be measured by the ton or by the square yard, compacted in place, for the thickness(es) specified.

304.08 Basis of Payment.

DELETE THE PAY ITEMS AND REPLACE THE WITH THE FOLLOWING:

Pay Item	Pay Unit
Aggregate Base Course (Class__) (__ inch thick)	Square Yard
Aggregate Base Course (Class__)	Ton
Subgrade Stabilization (Class__ Aggregate Base Course) (Complete in Place)	Ton, Cubic Yard

Payment for Subgrade Stabilization (Class __) (Complete in Place) shall be full compensation for all work necessary to complete the item including unclassified excavation and furnishing, placing and compacting the approved stabilization material. Proof Rolling, when required, will not be measured or paid for separately but shall be included in the work.

SECTION 306 - RECONDITIONING

306.02 Construction Requirements:

Replace the first two sentences of the paragraph with the following:

The soil below street subgrade elevation shall be reconditioned by removing the soil to the required depth, processing and replacing the material to the required density. Processing shall include mixing and adjusting the material to within two (2) percent of the optimum moisture content. After processing, the material shall be placed in uniform layers and compacted to the density specified in accordance with Table 1, page R&B 3. Subgrade reconditioning shall be performed over the full width of the roadway, including the area under curbs, gutters and sidewalks.

The depth of subgrade reconditioning shall be 12 inches unless otherwise specified in the contract documents or approved by the Engineer.

ADD THE FOLLOWING:

Proof Rolling. The Engineer or Construction Inspector may require proof rolling of the reconditioned subgrade to test for deflection . Proof rolling shall be in accordance with Subsection 203.09. If while proof rolling, any visible deflection or rutting is observed, additional reconditioning or recompaction of the subgrade may be required.

306.04 Basis of Payment.

ADD THE FOLLOWING:

The accepted quantities of reconditioning will be paid for at the contract unit price for reconditioning:

Payment will be made under:

Pay Item	Pay Unit
Reconditioning (___" deep)	Square yard

Proof rolling, when required, will not be measured or paid for separately but shall be included in the work.

SECTION 401 – HOT MIX ASPHALT PAVEMENTS - GENERAL

DELETE THE ENTIRE SECTION AND REPLACE IT WITH THE FOLLOWING:

SECTION 401 – Hot Mix Asphalt Pavements

401.01 Description

This work consists of one or more courses of hot mix asphalt (HMA) constructed on a prepared foundation in accordance with these specifications and the specific requirements of the type under contract. The placement of hot mix asphalt shall conform to the lines, grades, thickness and typical cross sections shown on the plans or established. Each course shall be compacted to the required density and approved before placement of the next course.

Hot Mix Asphalt (Patching) generally consists of patching damaged areas in existing pavement, utility trenches, areas removed for placement of curb and gutter forms, and other areas designated on the plans. See Section 401.04.14 for construction requirements.

401.02 Materials

401.02.1 Aggregates. Aggregates shall consist of crushed stone or crushed gravel with or without sand or other inert finely divided mineral aggregate. Aggregate properties shall meet the requirements of Table 401. The portion of material retained on the No. 4 sieve shall be known as coarse aggregate. The portion passing the No. 4 sieve shall be known as fine aggregate.

TABLE 401-1 Aggregate Properties		
Aggregate Test Property	Coarse – Retained on #4	Fine – Passing #4
Fine Aggregate Angularity CP 5113 Method A	-	45 % minimum
Two Fractured Faces	80% minimum	-
L.A. Abrasion AASHTO T 96	40% maximum	-
Flat & Elongated Pieces (Ratio 3:1) AASHTO M 283	10% maximum	-
Sodium Sulfate Soundness AASHTO T 104	12% maximum – Combined Coarse/Fine	
Adherent Coating (Dry Sieving) ASTM D 5711	0.5%	45% minimum
Sand Equivalent, AASHTO T 176	-	45% minimum
Plasticity Index AASHTO T 89, T 90	-	N.P.

Additionally, the aggregates should be composed entirely of angular, coarse textured, cube shaped particles. Natural (non-manufactured) sand may be used to obtain the gradation of the aggregate blend or to improve the workability of the mix. The amount of sand to be added shall not exceed 15 percent.

- (a) *Sampling and Testing.* Sampling of coarse and fine aggregate shall be in accordance with CP30. The Contractor shall furnish documentation to the Engineer confirming that the aggregates meet the specification requirements.
- (b) *Sources of Aggregates.* Sources of aggregates shall be designated by the Contractor with the submittal of the job mix formula.

401.02.2 Mineral Filler. If filler, in addition to that naturally present in the aggregate, is necessary, it shall meet the requirements of ASTM D 242.

401.02.3 Asphalt Cement. Asphalt cement shall be from an approved source and shall meet the requirements listed in Table 702-2 of the CDOT Standard Specifications for Road and Bridge Construction. Based on climatic conditions and reliability, binder grades approved for use in Grand Junction are as follows:

Recommended Binder Grades (Grand Junction, Colorado)

Condition	Non-modified Binder	Modified Binder
Free flowing traffic loads and <10,000,000 18k ESAL	PG 64-22	PG 64-28
Slow moving or standing trucks, major street intersections and /or ≥ 10,000,000 18k ESAL		PG 76-28
In lower layers of pavement (2" or more below top lift)	PG 58-28*	

* Use of a lesser grade of asphalt binder in the lower layers should be evaluated based on economics and availability of a lesser grade binder.

Binder grades other than those shown above shall not be used unless the proposed binder and the mix design are approved in writing by the City Project Engineer.

The Contractor shall furnish certified test reports for each delivery of bituminous material to be used on the project and shall retain a sample from each delivery. Each sample shall be large enough for future testing, if necessary. Samples of bituminous material shall be labeled with the asphalt grade, delivery date and project name, and stored by the Contractor for the duration of the project warranty period.

401.02.4 Reclaimed Material. Reclaimed Asphalt Pavement (RAP) shall be allowed in HMA up to a maximum of 20 percent provided that all the specifications for HMA are met. The producer shall submit a written Quality Control Plan and obtain approval by the Project Engineer before any HMA containing RAP is placed. The RAP shall be of uniform quality and shall not contain clay balls, vegetable matter or other deleterious substances. The maximum size of the RAP shall be 1-1/2 inches prior to introduction into the mixer.

If the Contractor proposes to use RAP in the hot bituminous pavement, a mix design with the proposed percentage of RAP and a separate mix design containing 100 percent virgin material shall be submitted to the City Project Engineer for approval. If at any time the mix fails to meet project specifications the contractor may be required to discontinue the use of RAP and utilize the approved mix design containing all virgin materials.

401.02.5 Preliminary Material Acceptance. Prior to delivery of materials to the job site, the Contractor shall submit test reports to the Engineer for the following materials:

- (a) *Coarse Aggregate in accordance with Subsection 401.02.1*
- (b) *Fine aggregate in accordance with Subsection 401.02.1*

(c) *Asphalt Cement in accordance with Subsection 401.02.3*

The test reports shall show the appropriate test(s) for each material, the test results and a statement that the material meets the specification requirement. The Engineer may request or obtain samples of materials for testing, prior to and during production to verify the quality of the materials and to ensure conformance with the applicable specifications.

401.03 Composition

401.03.1 Composition of Mixture. The HMA plant mix shall be composed of a mixture of well-graded aggregate, filler (if required), bituminous material and anti-stripping additive. Reclaimed material may be used only if approved in the job mix formula. The several aggregate fractions shall be sized, handled in separate size groups and combined in such proportions that the resulting mixture meets the grading requirements of the job mix formula (JMF).

401.03.2 Job Mix Formula. No HMA mixture shall be produced until the City Project Engineer has approved a job mix formula. The grading of bituminous mixture shall be as specified in Contract Documents. Mix designs shall be developed using Superpave mix design methods and shall be prepared in accordance with CDOT procedures and these specifications. The asphalt binder grade shall be in accordance with Section 401.02.3. The mix shall be treated with an approved anti-stripping agent. The amount of anti-stripping agent to be used shall be in accordance with the manufacturer's recommendations or the amount needed to produce a minimum tensile strength ratio (TSR) of 80, whichever is greater. Anti-stripping additives shall be heat stable, concentrated, refinery grade. Each mix design shall meet the requirements of Tables 401-1, 401-2 and 401-3 of this Section.

The job mix formula shall be submitted in typed form by the Contractor to the City Project Engineer at least 10 days prior to the start of paving operations and shall include the following:

- (a) Percent passing each sieve size for each product used and the combined grading.
- (b) Percent of asphalt cement.
- (c) Asphalt grade certification.
- (d) N Initial and N design information.
- (e) Mixing temperature.
- (f) Compaction temperature.
- (g) Temperature-viscosity relationship of the asphalt cement.
- (h) Plot of the combined gradation on a 0.45 power gradation curve.
- (i) Graphical plots, which bracket the optimum oil content for stability, air voids, voids in the mineral aggregate and unit weight verses asphalt content.
- (j) Percent of each aggregate product used.
- (k) Percent fractured faces.
- (l) Tensile strength ratio (TSR) at the proposed target asphalt content, including specific gravity, degree of saturation, effective voids, permeable voids, conditioned strength and unconditioned strength.
- (m) Anti-stripping agent - product name and manufacturer.
- (n) Specific gravity of each aggregate product and the combined specific gravity. Information shall include bulk dry, bulk saturated surface dry and apparent specific gravity for each aggregate. The effective specific gravity, water absorption and asphalt absorption shall be calculated and included.

- (o) Specific gravity of the asphalt cement.

TABLE 401-2 Design Criteria	
Test Property	Requirements
Stability	30 min.
Compaction Gyration (N_{design})	75*
Air Voids (percent by volume of mix)	3.0 to 5.0
Voids Filled (percent by volume of mix)	65 to 78
Voids in Mineral Aggregate	See Table 401-3

* On roadways with high traffic loading, N_{design} greater than 75 gyrations may be specified by the Engineer (See Table 2-1 in the CAPA Guideline for the Design and use of Asphalt Pavements for Colorado Roadways)

The Contractor shall submit samples to the City materials laboratory, upon request, for job mix formula verification testing.

The job mix formula for each mixture shall not be changed unless modifications are approved in writing by the City Project Engineer. Should a change in sources of materials be made, a new job mix formula must be prepared and submitted and approved by the Engineer before the new JMF is used.

TABLE 401-3 Voids in Mineral Aggregate (VMA)				
Nominal Maximum Particle Size *		Minimum VMA (percent)		
		Percent Design Air Voids		
mm	in.	3.0	4.0	5.0
75	#4	16.0	17.0	18.0
9.5	3/8	14.0	15.0	16.0
12.5	½	13.0	14.0	15.0
19	3/4	12.0	13.0	14.0
25	1	11.0	12.0	13.0
37.5	1 1/2	10.0	11.0	12.0
* The nominal maximum particle size is one size larger than the first sieve to retain more than 10 percent.				

The mineral aggregate shall be of such sizes that the percentage composition by weight, as determined by laboratory screens, conforms to the gradation or gradations specified in Table 401-4 when tested in accordance with CP31.

The gradations in Table 401-4 represent the limits that shall determine the suitability of aggregate for use from the sources of supply. The aggregate, as selected (and used in the job mix formula), shall have a gradation within the limits designated in Table 401-4 and shall not vary from the low limit on one sieve to the high limit on the adjacent sieve, or vice versa, but shall be well graded from coarse to fine.

Deviations from the final approved mix design for bitumen content and gradation of aggregates shall be within the action limits for individual measurements as specified in Table 401-7. The limits will still apply if they fall outside the master-grading band in Table 401-4 except for the top sieve sizes for each aggregate gradation product starting at the 100% passing band.

The maximum size aggregate used shall not be more than one-half of the thickness of the course being constructed.

TABLE 401-4 Aggregate Gradation for HMA Pavement		
	Percent by Weight Passing Sieves	
Sieve Size	Grading S	Grading SX
1 in.	100	100
3/4 in.	90 to 100	100
1/2 in.		90 to 100
3/8 in.		
No.4		
No.8	23 to 49	28 to 58
No. 200	2 to 7	2 to 8

Job mix control testing shall be performed by the Contractor at the start of plant production and in conjunction with the calibration of the plant for the job mix formula. It should be recognized that the aggregates produced by the plant may not satisfy the gradation requirements or produce a mix that exactly meets the job mix formula. In those instances, it will be necessary to reevaluate and redesign the mix using plant-produced aggregates. Specimens should be prepared and the optimum bitumen content determined in the same manner as for the original design tests.

401.03.3 Testing Laboratory. The laboratory used to develop the job mix formula shall meet the requirements of ASTM D 3666 and CDOT. A certification signed by the manager of the laboratory stating that it meets these requirements shall be submitted to the Engineer prior to the start of construction. The certification shall contain as a minimum:

- (a) Qualifications of laboratory manager, supervising technician and testing technicians.
- (b) A listing of equipment to be used in developing the job mix.
- (c) A copy of the laboratory's quality control system.
- (d) Evidence of participation in the AASHTO Materials Reference Laboratory (AMRL) program.

401.04 Construction Methods

401.04.1 Weather Limitations. Hot mix asphalt shall be placed only on properly constructed surfaces that are dry and free from snow, ice and frozen ground. The bituminous mixture shall be placed in accordance with the temperature limits shown in Table 401-5 and only when weather conditions permit the pavement to be properly placed and finished, as determined by the Engineer.

TABLE 401-5 Placement Temperature Limitations		
Compacted Layer Thickness in inches	Minimum Surface and Air Temperature °F	
	Top Layer	Layers Below Top Layer
<1 ½	60	50
1 ½ - <3	50	40
3 or more	45	35

When it is in the public interest and approved by the Engineering Manager, the minimum placement temperature requirements may be reduced however, paving operations shall be suspended when density requirements are not met.

401.04.2 HMA Mixing Plant. Plants used for the preparation of bituminous mixtures shall conform to the requirements of ASTM D 995 with the following changes:

- (a) *Truck Scales.* The bituminous mixture shall be weighed on approved scales furnished by the Contractor or on public scales at the Contractor's expense. Such scales shall be inspected and sealed as often as the Engineer deems necessary to assure their accuracy.
- (b) *Testing Facilities.* The Contractor shall provide laboratory facilities for the acceptance testing and the Contractor's quality control testing, in accordance with Paragraph 401.06.2.
- (c) *Inspection of Plant.* The Engineer or his authorized representative shall have access, at all times, to all areas of the plant for checking the adequacy of the equipment; inspecting the operation of the plant; verifying weights, proportions and material properties and checking the temperatures maintained in the preparation of the mixtures.
- (d) *Storage Bins and Surge Bins.* Use of surge bins or storage bins for temporary storage of hot bituminous mixtures will be permitted as follows:

The mix drawn from the storage bins shall meet the same requirements as the mix loaded directly into trucks. If the Engineer determines that there is an excessive amount of heat loss, segregation or oxidation of the mixture or other adverse effects on the quality of the finished product due to the temporary storage, corrective action shall be taken. Unsuitable mixture shall be disposed of at the Contractor's expense.

401.04.3 Hauling Equipment. Trucks used for hauling bituminous mixtures shall have tight, clean and smooth metal beds. To prevent the mixture from adhering to them, the truck beds shall be lightly coated with a minimum amount of paraffin oil, lime solution or other approved material. Each truck shall have a suitable cover to protect the mixture from adverse weather. When necessary, to ensure that the mixture will be delivered to the site at the specified temperature, truck beds shall be insulated or heated and covers shall be securely fastened.

401.04.4 HMA Pavers. Pavers shall be self-propelled, with an activated screed, heated as necessary and shall be capable of spreading and finishing courses of bituminous plant mix material which will meet the specified thickness, smoothness and grade. The pavers shall have sufficient power to propel themselves and the hauling equipment without adversely affecting the finished pavement surface.

The paver shall have a receiving hopper of sufficient capacity to permit a uniform spreading operation. The hopper shall be equipped with a distribution system to place the mixture uniformly in front of the screed without segregation. Each end of the auger shall not be more than 2 feet from the nearest end of the screed. The screed shall effectively produce a finished surface of the required evenness and texture without tearing, shoving or gouging the mixture.

The paver shall be capable of operating at forward speeds consistent with satisfactory laying of the mixture.

If an automatic grade control device is used, the paver shall be equipped with a control system capable of automatically maintaining the specified screed elevation. The control system shall be automatically actuated from a reference line or through a system of mechanical sensors or sensor-directed mechanisms which will maintain the paver screed at a predetermined transverse slope and at the proper elevation to obtain the required surface. The transverse slope controller shall be capable of maintaining the screed at the desired slope within plus or minus 0.1 percent. The controls shall be capable of working in conjunction with any of the following attachments:

- (a) Ski-type device of not less than 30 feet in length or as directed by the Engineer.
- (b) Taut string line (wire) set to grade.
- (c) Short ski or shoe.
- (d) Laser control.

401.04.5 Rollers. Rollers of the vibratory, steel wheel or pneumatic tire type shall be used. They shall be in good condition and capable of operating at slow speeds to avoid displacement of the bituminous mixture. The number, type and weight of rollers shall be sufficient to compact the mixture to the required density while it is still in a workable condition. The use of equipment which causes excessive crushing of the aggregate will not be permitted.

401.04.6 Preparation of HMA Material. The bituminous material shall be heated in a manner that will avoid local overheating and provide a continuous supply of the bituminous material to the mixer at a uniform temperature. The temperature of the bituminous material delivered to the mixer shall be sufficient to provide a suitable viscosity for adequate coating of the aggregate particles but shall not exceed 325 degrees F or the maximum temperature prescribed by the asphalt refiner, whichever is lower.

401.04.7 Preparation of Mineral Aggregate. The aggregate for the mixture shall be dried and heated prior to introduction into the mixer. The maximum temperature and rate of heating shall be such that no damage occurs to the aggregates. The temperature of the aggregate and mineral filler shall not exceed 350 degrees F when the asphalt is added. Particular care shall be taken that aggregates high in calcium or magnesium content are not damaged by overheating. The temperature shall not be lower than is required to obtain complete coating and uniform distribution on the aggregate particles and to provide a mixture of satisfactory workability.

401.04.8 Preparation of HMA. The dried aggregates and asphalt shall be combined in the mixer in the quantities required to meet the job-mix formula.

The combined materials shall be mixed until the aggregate is completely and uniformly coating and the asphalt is uniformly distributed throughout the aggregate. The moisture content of the

mix upon discharge shall not exceed 0.5 percent. The minimum temperature of the mixture measured behind the paver shall be as follows:

Asphalt Grade	Minimum Delivered Mix Temperature (°F)
PG 58-28	235
PG-64-22	235
PG 64-28	280
PG 76-28	280

401.04.9 Preparation of the Underlying Surface. Immediately before placing the bituminous mixture, the underlying course shall be cleaned of all dust and debris. A prime coat or tack coat shall be applied if required by the contract specifications.

401.04.10 Transporting, Placing and Finishing. The bituminous mixture shall be transported from the mixing plant to the point of use in vehicles conforming to the requirements of Paragraph 401.04.3. Deliveries shall be scheduled so the placing and compacting of all the mixture prepared for one day's run can be completed during daylight, unless adequate artificial lighting is provided. Hauling over freshly placed material shall not be permitted until the material has been compacted, as specified and allowed to cool to atmospheric temperature.

The mixture shall be distributed by bituminous pavers to the established grade, without segregation, over the entire width or partial width as practicable. It shall be struck off in a uniform layer of such depth that, when the work is completed, it shall have the required thickness and conform to the grade and contour indicated. Segregated areas behind the paver shall be removed upon discovery and replaced with material conforming to the specification before initial rolling. The speed of the paver shall be regulated to eliminate pulling and tearing of the bituminous mat.

In areas where irregularities or unavoidable obstacles make the use of mechanical spreading and finishing equipment impractical, the mixture may be spread, raked and luted by hand tools.

401.04.11 Compaction of Mixture. After placing, the mixture shall be thoroughly and uniformly compacted by rolling. The surface shall be compacted as soon as possible when the mixture has attained sufficient stability so the rolling does not cause undue displacement, cracking or shoving. The number, weight and type of rollers furnished shall be sufficient to obtain the required density while the mixture is in a workable condition. Compaction shall begin immediately after the mixture is placed and be continuous until the required density is obtained.

The speed of the roller shall, at all times, be sufficiently slow to avoid displacement of the hot mixture and be effective in compaction. Any displacement occurring as a result of reversing the direction of the roller or from any other cause shall be corrected at once.

Sufficient rollers shall be furnished to handle the output of the plant. Rolling shall continue until all roller marks are eliminated, the surface is of uniform texture and true to grade and cross section and the required field density is obtained.

To prevent adhesion of the mixture to the roller, the wheels shall be kept properly moistened, but excessive water will not be permitted.

In areas not accessible to the roller, the mixture shall be thoroughly compacted with hand mechanical tampers.

Any mixture that becomes loose and broken, mixed with dirt, contains check-cracking or in any way is defective shall be removed and replaced with fresh hot mixture and immediately compacted to conform to the surrounding area. This work shall be done at the Contractor's expense. Skin patching shall not be allowed. While the surface is being compacted and finished, the Contractor shall carefully trim the outside edges of the pavement to the proper alignment. Edges so formed shall be beveled while still hot with the back of a rake or a smoothing iron and thoroughly compacted by tampers or by other satisfactory methods.

401.04.12 Joints. The formation of all joints shall be made in such a manner as to ensure a continuous bond between the courses and obtain the required density. All joints shall have the same texture, density and smoothness as other sections of the course and meet the requirements for smoothness and grade.

The roller shall not pass over the unprotected end of the freshly laid mixture except when necessary to form a transverse joint. When necessary to form a transverse joint, it shall be made by means of placing a bulkhead or by tapering the course. The tapered edge shall be cut back to its full depth and width on a straight line to a 1:1 slope prior to placing the adjacent lane. In both methods, all contact surfaces shall be given a tack coat of bituminous material before placing any fresh mixture against the joint.

Longitudinal joints in both a new pavement and an overlay pavement layer shall offset the joint in the layer immediately below by at least six inches. The joints in any pavement layer shall not fall in a wheel track. Joints which are irregular, damaged or otherwise defective shall be cut back to expose a clean, sound surface for the full depth of the course. All contact surfaces shall be given a tack coat of bituminous material prior to placing any fresh mixture against the joint.

401.04.13 Lift Thickness. Each layer of compacted bituminous pavement shall be of uniform thickness. The minimum compacted thickness of each layer shall be 1 ½ inches and the maximum layer thickness shall be 3 inches. The top layer on all nonresidential streets shall not exceed 2 inches compacted thickness. The minimum pavement thickness on residential streets shall be 3 inches.

401.04.14 Patching. All trenches and excavations in City streets shall be backfilled and patched with plant mix asphalt before the street is reopened to traffic unless otherwise approved by the Engineer. The top layer of all patches that are 6' or greater in width and 35' or greater in length shall be paved with an asphalt paving machine.

When the Engineer approves the opening of a roadway to traffic before the trench or other excavation has been patched, the Contractor shall maintain a smooth dust free surface until the permanent patch is installed.

The area to be patched shall be squared off and the edges neatly cut in accordance with Subsection 202.09. The edges of the patch shall be offset no less than 12 inches beyond the top edges of the trench or excavation. Longitudinal Joints in streets shall be located at the edge of a bike lane, or at the center or edge of a traffic lane. Prior to patching, the edges of the existing pavement shall be tack coated with emulsified asphalt (slow-setting). Hot mix asphalt

shall be placed and compacted in layers of uniform thickness to the same thickness as the adjacent asphalt, unless otherwise approved by the Engineer. The minimum compacted thickness of each layer shall be 1 ½ inches and the maximum layer thickness shall be 3 inches, except that the thickness of the top layer shall not exceed 2 inches.

401.05 Material Acceptance

401.05.1 Acceptance Testing. The owner shall be responsible for acceptance testing for air voids, voids in mineral aggregate (VMA), surface smoothness and mat density to determine conformance with the requirements specified in this section. Acceptance testing of plant produced materials for material gradation and asphalt content shall be performed by the Contractor. All failing tests shall be immediately reported to the City's Quality Assurance Technician (QAT) and addressed by the Contractor. Test results from sub-lots of each day's production shall be completed and submitted to the City's QAT for review prior to the next day's production. Acceptance testing frequency and tolerance limits are summarized in Table 401-8 (Acceptance Testing Schedule).

Personnel performing sampling and testing of HMA in the lab and field shall possess the appropriate CAPA (LabCat) certification or combination of certifications for all sampling and testing performed.

(a) *Plant-Produced Material.* Plant-produced material shall be tested for air voids and voids in mineral aggregate (VMA) on a sub-lot basis. Sampling may be at the plant or at the job site. A sub-lot will consist of:

- production not to exceed 1000 tons
- increments of 1000 tons
- one day's production.

(1) *Sampling.* Each lot will consist of a minimum of three sub-lots. Sufficient material for preparation of test specimens shall be sampled by the Contractor on a random basis, in accordance with the procedures contained in CP41 and as directed by the Engineer. Samples shall be split with owner's materials laboratory. One set of laboratory compacted specimens will be prepared for each sub-lot in accordance with CDOT recommendations and practices, at the number of gyrations required in Table 401-2 under Paragraph 401.03.2. Each set of laboratory compacted specimens will consist of three test portions prepared from the same sample increment.

The sample of bituminous mixture may be put in a covered metal tin and placed in an oven for not more than two hours to maintain heat prior to splitting samples for testing. The compaction temperature of the specimens shall be as specified in the job mix formula.

(2) *Testing.* Air Voids and VMA shall be determined in accordance with AASHTO T 269 and CP48, respectively.

For air voids determination, the theoretical maximum specific gravity of the mixture shall be determined in accordance with CP51. The value used in the

voids computation for each sub-lot shall be the average of the maximum specific gravity measurements for the lot.

Air voids and VMA for each sub-lot shall be computed by averaging the results of the test specimens representing that sub-lot.

Gradation and asphalt content testing shall be the responsibility of the Contractor and shall be part of the Contractor's quality control program as stated in subsection 401.06.3.

- (3) *Acceptance.* Acceptance of the plant produced material for air voids and VMA shall be determined by the City in accordance with the requirements of Paragraph 401.05.2(b). Acceptance of the plant produced material for gradation and oil content shall be in accordance with the requirements of Paragraphs 401.05.2(f) and 401.05.2(g).
- (b) *Field Placed Material.* Asphalt pavement shall be tested for in-place density on a sub-lot basis.
- (1) *In-Place Density.* The lot size shall be the same as that indicated in Paragraph 401.05.1(a) and shall be divided into equal sub-lots. Densities shall be determined in accordance with CP81. The nuclear densimeter shall be calibrated to a minimum of six cores taken from the same material. Calibration shall be performed once for each approved mix design.
 - (2) *Core Sampling.* Samples shall be neatly cut with a core drill or other approved equipment. The minimum diameter of the sample shall be three inches. Samples that are clearly defective, as a result of sampling, shall be discarded and another sample taken. Cores shall not be taken closer than one foot from a transverse or longitudinal joint. The Contractor shall furnish all tools, labor and materials for cutting samples and filling the cored pavement. The Contractor shall be responsible for supplying the City materials laboratory with the core samples. Cored holes shall be filled in a manner acceptable to the City and within one day after sampling.
 - (3) *Testing.* The percent relative compaction (density) shall be determined by dividing the density reading of the nuclear densimeter or core by the maximum density of the product as determined by CP51. The testing frequency shall be 1 per 500 sq. yd.
- (3) *Acceptance.* Acceptance of field placed material for mat density will be determined by the City in accordance with the requirements of Paragraph 401.05.2(c).

401.05.2 Acceptance Criteria.

- (a) *General.* Acceptance will be based on the following characteristics of the bituminous mixture and completed pavement as well as the implementation of the Contractor's Quality Control plan and test results:

City of Grand Junction, Colorado
Standard Specifications for Road and Bridge Construction

- (1) Air Voids
- (2) Voids in Mineral Aggregate (VMA)
- (3) Mat Density
- (4) Surface Smoothness
- (5) Gradation

(b) *Air Voids and Voids in Mineral Aggregate.* If the materials are within the specification limits, the lot shall be acceptable. Payment shall be made in accordance with Paragraph 401.08.1(a). Acceptance of each lot of plant produced material for air voids and VMA shall be based on the quality level (QL) as determined by the percentage of material within specification limits. The QL procedure considers the variability (standard deviation) of the material and the testing procedures, as well as the average (mean) value of the test results. The QL shall be based on the results of a minimum of three (3) consecutive samples or sub-lots.

For projects where less than three samples are required under Paragraph 401.05.1(a), acceptance of the material shall be based on the individual tests meeting the tolerances of Table 401-5 and adherence to the job mix formula.

- (c) *In-Place Density.* Acceptance of each lot of in-place pavement for mat density shall be based on the quality level (QL). An average density shall be established from the nuclear density readings of each sub-lot.
- (d) *Quality Level (QL).* The percentage of material within specification limits shall be used to *determine* the quality level in accordance with CP71. The specification tolerance limits are contained in Table 401-6.

TABLE 401-6 Acceptance Limits – Air Voids, VMA, Density		
Test Property	Lower Specification Tolerance Limit (T_L)	Upper Specification Tolerance Limit (T_U)
Air voids total mix	2.8	5.2
Voids in Mineral Aggregate	See Table 401-3	N/A
Percent Relative Compaction (in-place density)	92.0%	96.0%

(e) *Surface Smoothness.* When requested by the Engineer, the finished surface of the pavement shall be measured, using a 10-foot straightedge. The Contractor shall furnish an approved 10-foot straightedge and depth gauge and provide an operator to aid in measuring the finished pavement surface. Locations to be measured shall be as directed by the Engineer or the Construction Inspector. Areas showing high spots or sags of more than 3/16 inch, either transverse or longitudinally, shall be marked and corrected by diamond grinding, seamless infrared heat patching or other approved method until the high spots and/or sags do not exceed 3/16 inch. All areas ground or patched shall be neat rectangular areas of uniform surface.

- (f) *Gradations.* Gradations as part of the Contractor's Quality Control Plan, shall be accepted, provided that they fall within the Action Limits shown in Table 401-6. Two consecutive gradations falling outside the action limits or one gradation falling outside the Suspension Limits will warrant corrective action and shall be subject to engineering review and possible removal and replacement of the represented day's production.
- (g) *Asphalt Content.* Asphalt content shall be determined as part of the Contractor's Quality Control. If the materials are within the specification limits, the lot shall be acceptable. Payment shall be made in accordance with Paragraph 401.08.1(a). Volumetrics falling outside the limits of the job mix formula will warrant corrective action which may include removal and replacement of the represented day's production.

401.05.3 Re-sampling Pavement.

- (a) Will consist of all the sampling and testing procedures contained in Paragraphs 401.05.1(b) and 401.05.2(c). Only one re-sampling per lot will be permitted.
 - (1) A redefined QL shall be calculated for the re-sampled lot. The number of tests used to calculate the redefined QL shall include the initial tests made for that lot plus the re-tests.
 - (2) The cost for re-sampling and re-testing shall be borne by the Contractor.
- (b) *Payment for Re-sampled Lots.* The redefined QL for a re-sampled lot will be used to calculate the payment for that lot in accordance with Table 401-7.
- (c) *Outliers.* If the tests within a lot include a very large or a very small value which appears to be outside the normal limits of variation, check for an outlier in accordance with ASTM E 178, at a significance level of 5 percent, to determine if this value should be discarded when computing the QL.

401.05.4 Leveling Course. Any course used for truing and leveling prior to overlay shall meet the requirements of Paragraph 401.03.2 and 401.05.2(b), but shall not be subject to the density requirements of Paragraph 401.05.2(c) and 401.05.2(d). The leveling course is of variable thickness and is the first lift of an overlay placed prior to the intermediate or surface course. The leveling course shall be compacted with a pneumatic roller.

401.06 Contractor Quality Control

401.06.1 General. The Contractor shall develop a Quality Control Program. The program shall address all elements which affect the quality of the pavement including, but not limited to:

- (a) Mix Design
- (b) Aggregate Grading
- (c) Quality of Materials
- (d) Stockpile Management
- (e) Proportioning
- (f) Mixing and Transportation
- (g) Placing and Finishing
- (h) Asphalt Content
- (i) Compaction

(j) Surface Smoothness

401.06.2 Testing Laboratory. The Contractor shall provide a fully equipped asphalt laboratory or shall hire an independent testing laboratory for quality control testing.

Laboratory facilities shall be kept clean and all equipment shall be maintained in proper working condition. The City's designated representative shall be permitted unrestricted access to inspect the Contractor's laboratory facility and witness quality control activities. The City's representative will advise the Contractor in writing of any noted deficiencies concerning the laboratory facility, equipment, supplies, testing personnel and testing procedures. When the deficiencies are serious enough to be adversely affecting test results, the incorporation of the materials into the work shall be suspended immediately and will not be permitted to resume until the deficiencies are satisfactorily corrected.

401.06.3 Quality Control Testing. The Contractor shall develop a quality control testing plan and perform all quality control tests necessary to control the production and construction processes applicable to these specifications. Quality control test results shall be submitted to the City QAT within 24 hours of sampling.

Personnel performing sampling and testing of aggregates or HMA in the lab and in the field shall possess the appropriate CAPA (LabCAT) certification or combination of certifications for all sampling and testing performed.

The quality control testing plan shall include, but not necessarily be limited to, the following tests:

- (a) *Asphalt Content.* One extraction test shall be performed per sub-lot in accordance with CP42, method "A" for determination of asphalt content and shall be sampled at the same time as the VMA and air voids samples are obtained. The use of the nuclear methods for determining asphalt content in accordance with CP42, method "E" is permitted, provided that it is calibrated for the specific mix being used. The Ignition Method, CPL 5120 is also acceptable.
- (b) *Gradation.* Aggregate gradations shall be determined from mechanical analysis of extracted aggregate in accordance with CP31. When asphalt content is determined by the nuclear method, aggregate gradation shall be determined from hot bin samples on batch plants or from the cold feed on drum mix or continuous mix plants. The samples shall be tested in accordance with CP31 using actual batch weights to determine the combined aggregate gradation of the mixture.
- (c) *Moisture Content of Aggregate.* The moisture content of the aggregate used for the production shall be determined a minimum of once per lot in accordance with AASHTO T 255.
- (d) *Moisture Content of Mixture.* The moisture content of the mixture shall be determined once per lot in accordance with AASHTO T 110 or CP42.
- (e) *Temperatures.* Temperatures shall be checked, at least twice per day, at necessary locations to determine the temperatures of the dryer, the bitumen in the storage tank, the mixture at the plant and the mixture at the job site.

- (f) *In-Place Density Monitoring.* It is recommended that the Contractor conduct testing to ensure that the specified density is being achieved. A nuclear gauge shall be used to monitor the pavement density in accordance with CP81.
- (g) *Additional Testing.* Any additional testing that the Contractor deems necessary to control the process may be performed at the Contractor's option.
- (h) *Monitoring.* The Engineer and/or the City reserve the right to monitor any of the quality control tests listed above and to perform verification sampling and testing of all materials.

401.06.4 Sampling. When directed by the City, the Contractor shall sample and test any material that appears inconsistent with similar material being sampled, unless such material is voluntarily removed and replaced or deficiencies corrected by the Contractor. All sampling shall be in accordance with standard procedures specified.

401.06.5 Control Charts. It is recommended that the Contractor maintain linear control charts both for individual measurements and ranges (i.e., difference between highest and lowest measurements) for aggregate gradation and asphalt content.

TABLE 401-7 Control Limits for Individual Measurements		
Test Property	Action Limit	Suspension Limit
Asphalt Content	N/A	N/A
Gradation (% passing)		
1 in.	0%	0%
3/4 in.	+/- 6%	+/- 8%
1/2 in.	+/- 6%	+/- 8%
3/8 in.	+/- 6%	+/- 8%
No. 4	+/- 5%	+/- 6.5%
No. 8	+/- 5%	+/- 6.5%
No. 30	+/- 4%	+/- 5.5%
No. 200	+/- 2%	+/- 3%

- (a) *Corrective Action.* The Quality Control Plan shall indicate that appropriate action will be taken when the process is found to be out of control. The Plan shall contain rules to gauge when a process is out of control and detail what action will be taken to bring the process into control. A process shall be deemed out of control, production stopped and corrective action taken if:
- (1) one point falls outside the Suspension Limits for individual measurements; or
 - (2) two points in a row fall outside the Action Limits for individual measurements.

401.07 Method of Measurement

401.07.1 Method of Measurement. Hot mix asphalt will be measured by the ton or by the square yard in accordance with the Pay Units listed in the Bid Schedule. Batch mass (weights) will not be permitted as a method of measurement. The tonnage shall be the weight used in the accepted pavement.

401.08 Basis of Payment

401.08.1 Payment. The accepted quantities of HMA will be paid for at the adjusted contract unit price for each pavement type and/or thickness listed in the bid schedule. The adjusted price will be full compensation for furnishing all materials, for preparation, mixing, placing and compaction of these materials and for all labor, equipment, tools and incidentals necessary to complete the work.

Unit price adjustment. Each lot will be paid for at the adjusted unit price determined by multiplying the contract unit price by the pay factor (PF). The PF shall be calculated in

City of Grand Junction, Colorado
Standard Specifications for Road and Bridge Construction

accordance with Table 401-8. The PF shall be calculated for mat density, air voids and VMA. The payment shall be based on the lowest of the PF values. The price adjustment shall apply to the bituminous pavement only.

TABLE 401-8 Formulae for Calculating Pay Factor		
Number of sublots	Pay Factor (PF) formula – based on number of sublots	Maximum PF
3	$0.31177 + 1.57878 (QL/100) - 0.84862 (QL/100)^2$	1.025
4	$0.27890 + 1.51471 (QL/100) - 0.73553 (QL/100)^2$	1.030
5	$0.25529 + 1.48268 (QL/100) - 0.67759 (QL/100)^2$	1.030
6 – 7	$0.19468 + 1.56729 (QL/100) - 0.70239 (QL/100)^2$	1.030
8 – 11	$0.16394 + 1.55070 (QL/100) - 0.65270 (QL/100)^2$	1.030
12 – 18	$0.07278 + 1.64285 (QL/100) - 0.65033 (QL/100)^2$	1.030
19 – 37	$0.09907 + 1.43088 (QL/100) - 0.45550 (QL/100)^2$	1.030

QL shall be determined in accordance with Colorado Procedure 71 (CP71).

For projects with less than three sub-lots, payment shall be 100% provided that the materials tested meet the requirements of Section 401.05.2. Failing test results will constitute re-testing of the materials. If re-tests confirm that there are deficiencies and/or materials fall outside the limitations of the job mix formula or specifications, a pay adjustment factor will be calculated and applied to each sub-lot or the pavement may be rejected.

Payment will be made under:

Pay Item	Pay Unit
Hot Mix Asphalt (____" thick) (Grading _____, Binder Grade PG_____)	Square Yard
Hot Mix Asphalt (Grading _____, Binder Grade PG_____)	Ton
Hot Mix Asphalt (Patching)(____" thick)(Grading, _____, Binder Grade PG_____)	Square Yard
Hot Mix Asphalt (Patching)(Grading_____, Binder Grade PG_____)	Ton

401.09 Private Development -- Quality Assurance and Acceptance

401.09.1 Job Mix. The requirements for bituminous mix materials and testing of such materials shall conform to Subsections 401.01, 401.02 and 401.03.

401.09.2 Sampling and Testing. Quality assurance (QA) testing shall be performed in accordance with Table 401-9. Sampling and testing shall be performed by an approved

City of Grand Junction, Colorado
Standard Specifications for Road and Bridge Construction

independent Testing Laboratory at the expense of the owner. The owner's Engineer shall monitor the testing. All failing tests shall be immediately presented to the Engineer by the Testing Laboratory.

- (a) *Plant-Produced Material.* Plant-produced material shall meet the requirements for air voids and voids in the mineral aggregate as specified in Table 401-8 and shall fall within the limits of the Job Mix Formula for gradation. The testing schedule shall be as set forth in Table 401-8.
- (b) *Field Placed Material.* Field placed material shall meet the requirements for percent relative compaction and surface smoothness as set forth in Table 401-8.

TABLE 401-9 Acceptance Testing Schedule			
Test Property	Procedure	Specification Tolerance Limits	Frequency
Asphalt Content (QC)	CP42 Method "A" or "E" CPL 5120	NA	1 per 1000 Tons or 1 per day min.
Gradation (QC)	CP31	see Table 401-6	1 per 1000 Tons or 1 per day min.
Air Voids (QA)	AASHTO T 269	2.8 to 5.2	1 per 1000 Tons or 1 per day min.
Voids in Mineral Aggregate (QA)	CP48	see Table 401-2	1 per 1000 Tons or 1 per day min.
Percent Relative Compaction (QA)	CP51	92% to 96%	1 per 500 Sq Yd
Surface Smoothness	Section 401.05.2(e)	3/16 in. per 10 ft.	Test locations may identified by the Engineer or the City

The Engineer or the City may request samples for testing during production to verify the quality of the materials and to ensure conformance with the applicable specifications.

City Acceptance. Acceptance of asphalt pavement in new developments shall be based on the criteria listed Table 401-9. If test results for air voids, VMA or percent relative compaction are not within tolerance limits the material should be re-tested. If the re-tested material fails to meet specification tolerance limits, the Developer will be required to either pay a cost reduction fee to the City of Grand Junction or remove and replace the pavement in accordance with Subsection 401.09.4 or 401.09.5

401.09.3 Laboratory and Testing Requirements. All sampling and testing shall be performed using the proper equipment as required by each test procedure. Personnel performing sampling and testing of bituminous mixtures in the lab and in the field shall possess the appropriate CAPA (LabCat) certification or combination of certifications for all sampling and testing performed.

City of Grand Junction, Colorado
Standard Specifications for Road and Bridge Construction

401.09.4 Cost Reduction Fee (less than three tests). In cases where a lot is represented by less than three tests or sub-lots, each test will be considered as a separate lot for the determination of a cost reduction factor (P) and a cost reduction fee. A cost reduction factor shall be calculated for each lot that has test properties outside the tolerance limits shown in Table 401-6. Where more than one of the three test properties are out of tolerance limits, the cost reduction factor shall be calculated for each test property and the largest value (P) shall be used to determine the cost adjustment. The cost adjustment fee will be determined by multiplying P by the total in- place cost of pavement in the lot. Any cost adjustment factor of 50% or more will constitute removal and replacement the entire lot. All calculations are rounded to the nearest whole number.

Table for "F" Factor	
Element	"F" Factor
Voids	83
VMA	83
Field Density	33

Cost Adjustment Voids	
Percent Above or Below Limits	Adjustment as a Percentage (P)
0.1	6
0.2	12
0.3	19
0.4	25
0.5	31
0.6	37
0.7	44
0.8	50

City of Grand Junction, Colorado
Standard Specifications for Road and Bridge Construction

Cost Adjustment VMA	
Percent Below Limits	Adjustment as a Percentage (P)
0.1	6
0.2	12
0.3	19
0.4	25
0.5	31
0.6	37
0.7	44
0.8	50

Cost Adjustment Field Density	
Percent Above or Below Limits	Adjustment as a Percentage (P)
1.0	25
2.0	50

$$P = 0.75F(T_o - T_u)$$

$$P = 0.75F(T_l - T_o)$$

T_o = Test Result
 T_u = Upper Limit
 T_l = Lower Limit

It is recommended that the contractor and testing lab obtain enough sample to allow additional testing if the initial tests are outside the acceptable specification limits.

401.09.5 Cost Reduction Fee (three or more tests). When a lot is represented by three or more tests or sub-lots, the pay factor (PF) shall be calculated in accordance with Subsection 401.08.1 for each test property listed in Table 401-6 that is outside the tolerance limits. Where more than one of the three test properties are out of tolerance limits, a pay factor shall be calculated for each test property and the smallest percentage value (PF) shall be used to determine the cost reduction fee. The cost reduction fee will be determined from the following formula:

$$\text{Cost Reduction Fee} = C(1 - PF) \text{ where } C \text{ is the in-place cost of the lot.}$$

Any cost adjustment of 50% or more will constitute removal and replacement the entire lot. All calculations are rounded to the nearest whole number.

SECTION 403 - HOT MIX ASPHALT

THE ENTIRE SECTION HAS BEEN DELETED. REFER TO REVISED SECTION 401 - **HOT MIX ASPHALT PAVEMENTS**.

SECTION 405 – HEATING AND SCARIFYING TREATMENT

ADD THE FOLLOWING:

405.03 Seamless Patching with Infrared Heating Process. This work shall consist of repairing or patching asphalt pavement utilizing infrared equipment to heat the existing pavement within and adjacent to the area to be patched or repaired and placing new HMA in the prepared area. This method may also be used to repair temporary or hand placed patches. Infrared Heating during pavement repair is intended to provide a seamless patch restoring the disturbed area to a smooth, homogeneous pavement. Infrared heating and scarifying shall be used where specified in the contract documents or as directed by the Engineer.

The equipment used for heating pavement must be capable of producing a true infrared ray with a minimum of convection heat. The area to be patched shall be cleaned and free of dirt, rock and other debris. The infrared heater shall be positioned over the patch area in such a way to insure heating a minimum of twelve inches beyond the edge(s) of the existing pavement. The heating time will be approximately seven minutes, depending upon the ambient temperature and condition of the pavement. An experienced operator shall determine exactly when optimum-heating penetration has occurred. Overheating shall be avoided to prevent damage to the asphalt binder. After heating, the area to be patched shall be neatly outlined (picture framed) with the back of an asphalt rake. The boundary of this area shall be approximately six inches within the heated area. Using the ling tongs of the asphalt rake, this area shall be thoroughly scarified. An asphalt-rejuvenating additive, if needed, shall be added during the scarifying process. New HMA shall be added to bring to area up to grade allowing for compaction. The HMA shall be placed at a temperature between 270 and 300 degrees F. This may be accomplished by the use of an infrared storage unit or other approved method. Compaction shall be accomplished by the use of a vibratory pavement roller with capacity equal to a three to five ton static roller. Proper techniques shall be used to achieve the required density and surface smoothness in accordance with Section 401.05.2.

405.04 Method of Measurement. The accepted quantities of *Infrared Heating and Scarifying* will be measured by determining the area of pavement heated and scarified as directed or approved by the Engineer.

405.05 Basis of Payment. The unit price for *Infrared Heating and Scarifying* shall be full compensation for all equipment and labor required for heating, rejuvenating and scarifying the existing pavement and blending new hot mix asphalt into the area being patched or repaired, The furnishing, placing, leveling and compaction of new HMA used during the infrared heating and patching process will be paid for separately under the items listed in Subsection 401.08.1 for *Hot Mix Asphalt (patching)*.

City of Grand Junction, Colorado
Standard Specifications for Road and Bridge Construction

Payment will be made under:

Pay Item	Pay Unit
Infrared Heating and Scarifying	Square Yard

SECTION 407 - PRIME COAT, TACK COAT AND REJUVENATING AGENT

407.02 Bituminous Material.

ADD THE FOLLOWING:

Bituminous material for tack coat shall be cationic emulsified asphalt (CSS-1h) conforming to the requirements of Section 702.03 of the CDOT Standard Specifications unless otherwise specified or approved.

Asphalt for prime coat shall be cutback asphalt grade MC-70 unless otherwise specified or approved by the Engineer.

407.07 Application of Bituminous Material.

ADD THE FOLLOWING:

Prime coat (MC-70) shall be uniformly applied over the entire surface of the base course at a rate of 0.3 gallons per square yard to the surface of the aggregate base course. Application rates for other approved asphalt grades or prime coat products shall be in accordance with the manufacturer's recommendations or as directed by the Engineer.

Tack coat shall consist of emulsified asphalt (CSS-1h) mixed at a rate of one gallon of water for each gallon of emulsion. Tack coat shall be uniformly applied between layers of hot bituminous pavement at a rate of 0.1 gallon per square yard. Tack coat shall also be applied to the edges of existing pavements which are to be adjacent to new pavement.

SECTION 412 - PORTLAND CEMENT CONCRETE PAVEMENT

412.03 Classification.

DELETE AND REPLACE WITH THE FOLLOWING:

Concrete shall conform to the requirements for Class P unless otherwise specified or approved.

412.17 Surface Smoothness Test.

REVISE SUBSECTION 412.17 AS FOLLOWS:

Roadway smoothness shall be tested as described below. Roadway smoothness testing will not be measured and paid for separately, but shall be included in the work.

The finished surface elevation of the pavement will be measured using a 10 foot straightedge both transverse and longitudinally. The Contractor shall furnish an approved 10 foot straightedge and depth gauge and provide an operator to aid the engineer in testing the finished pavement surface. Areas to be measured shall be as directed by the Engineer. Areas showing high spots of more than 3/16 inch in ten feet shall be marked and diamond ground until the high spot does not exceed 3/16 inch in ten feet. Additional diamond grinding shall be performed as necessary to extend the area ground in each lateral direction so that the lateral limits of grinding are at a constant offset from a line parallel to the nearest lane line or pavement edge, and in each longitudinal direction so that the grinding begins and ends at lines normal to the pavement centerline within the ground area. All ground areas shall be neat rectangular areas of uniform surface.

SECTION 420 - GEOSYNTHETICS

420.02 Materials

ADD THE FOLLOWING:

Geogrid used for reinforcement of aggregate base course or for subgrade stabilization/separation shall meet the minimum strength and other physical properties specified in the project contract documents and shall be approved by the Engineer prior to placement.

420.10 Basis of Payment

ADD THE FOLLOWING:

Geogrid will be paid for under:

Pay Item	Pay Unit
Geogrid	Square Yard

SECTION 504 - CRIBBING

504.01 Description.

ADD THE FOLLOWING PARAGRAPH TO THE END OF SUBSECTION 504.01:

This work also consists of constructing concrete block facing Mechanically Stabilized Earth (MSE) Retaining Wall Systems at the locations and to the lines and grades shown on the plans.

504.02 Materials.

ADD THE FOLLOWING TO THE END OF SUBSECTION 504.02:

(d) *MSE Walls*: Materials for construction of MSE walls shall conform to the following:

Granular leveling pads shall be constructed with Class 6 aggregate base course conforming to Subsection 703.03 and sand for fine grading.

Concrete leveling pads shall be constructed with Class B concrete conforming to Section 601.

Backfill shall be Structure Backfill (Class 1) conforming to Subsection 703.08 (a).

Impervious membranes shall conform to the requirements of Subsection 712.08 for Geomembrane, and shall be a minimum of 30 mil in thickness, either with dual track field seamed PVC liner or with a 8" minimum width lap and fold waterproof connection.

Geosynthetic soil reinforcement shall be a geogrid or geotextile, including polyester (PET), polypropylene (PP) and high density polyethylene (HDPE) reinforcement products. The material shall comply with the manufacturer's recommendations for the configuration of MSE wall being constructed.

Concrete block facing units shall conform to the following specifications:

- The cementitious materials shall be Portland cement which shall conform to the requirements of ASTM C 150. Fly ash may be used but shall not exceed 20% by weight of the total cement content and shall conform to the requirements of ASTM C 618.
- Aggregates used in the manufacture of the units shall conform to the requirements of ASTM C 33 for normal weight concrete aggregate.
- Color, texture and pattern shall be as specified on the Construction Plans.
- All units shall be in good condition. Cracks, chips and/or other imperfections may be cause for rejection, as determined by the Engineer.
- The average compressive strength shall be equal or greater than 3000 psi in accordance with ASTM C 90.
- The minimum oven dry weight of concrete block shall be 125 pcf with a maximum water absorption rate by weight of 6 percent determined in accordance with the requirement of ASTM C 140.

- The permissible variations in the exterior dimensions of the concrete block shall not differ more than $\pm 1/8$ ", except the height of the block shall be within $\pm 1/16$ " from the specified dimensions for an individual block. The minimum thickness of any walls or webs within the block shall be on average 3" at the face and 2" at stem and back. The vertical edges, if applicable, shall be chamfered for splitting and precise dimensioning.

504.03 Construction Requirements.

ADD THE FOLLOWING TO THE END OF SUBSECTION 504.03:

Construction requirements for MSE walls shall conform to the following:

- (a) *Excavation and Backfill.* Should the excavation for the placement of the leveling pad expose an unsatisfactory bearing material the Engineer may require removal and replacement of that material. The removed material shall be replaced with Structure Backfill (Class 1) compacted in conformity to Subsection 206.03 except that the density shall be 100 percent AASHTO T-180. Payment for removal and replacement shall be in accordance with the Standard Specifications.

The reinforced fill and the upper triangular fill portion immediately behind it as defined on the plans shall be Structure Backfill (Class 1) compacted in conformity to subsection 206.03. Unless otherwise noted on the plans, recycled asphalt and flow-fill material is not allowed to substitute Structure Backfill (Class 1). Each layer of backfill shall not exceed 8" before compacting to the required density and before successive layers are placed. At least 6" of material shall be in place prior to operation of tracked vehicles over the reinforcements. Only hand-operated compaction equipment shall be allowed within 3' of the front of the wall face and compaction in these areas shall conform to subsection 206.03.

The fill and compaction operation shall progress from the face toward the back. The verification of 95% AASHTO T-180 compaction is absolutely required behind the blocks, for a distance equal to reinforcement vertical spacing, unless pea gravel is used to fill the top triangular portion above the structure backfill spill zone.

The Contractor shall place additional blocks and fill material, properly compacted, to return the finished grade to plan elevations if settlement as determined by the Engineer has occurred. A final inspection before the installation of rail anchoring slab, if applicable, shall be made 30 to 45 days after the completion of the top layer of blocks.

If the settlement is determined to be the result of the non-conforming backfill or backfill not meeting compaction requirements, the Contractor shall bring the elevation to the finished grade at no extra cost to the project.

- (b) *Reinforcement.* The reinforcement shall be laid to within 1" from the front face of block. For geosynthetic sheet reinforcement there shall be a minimum of 6" overlapping between rolls. Correct orientation of the geosynthetic reinforcement shall be verified by the Contractor to be in accordance with the geosynthetic manufacturer's recommendations. The highest strength direction of the geosynthetic shall be perpendicular to the wall face. Geosynthetic reinforcement layers shall be one

continuous piece for their entire embedment length

Unless otherwise required on the plans the length of soil reinforcement shall be equal from top to bottom at all layers of wall.

The first (bottom) layer of soil reinforcement shall be no farther than 16" average above the top of the leveling pad. The last (top) layer of soil reinforcement shall be no farther than 20" average below the top of the uppermost concrete block. The maximum vertical spacing between layers of adjacent soil reinforcement shall not exceed 24" for block width ≤ 12 " (measured from front to back), nor 32" for block width > 12 ".

- (c) *Leveling Pad.* The leveling pad shall be level within the tolerance of 1/2" for any two points, and within 1/4" for any two points 10' apart.

A layer of thin cushion or shimming material (Expansion Joint Material, Concrete Motor Grout, Roofing Felt, Geosynthetic Reinforcement) shall be applied between a concrete leveling pad and the first layer of blocks. A 1" layer of sand shall be applied between a compacted granular leveling pad and the first layer of blocks. Before starting a new course of blocks, the Contractor shall take steps to ensure matching the elevation at the next leveling pad step. Layer(s) of cushion or shimming material shall be used to obtain necessary block elevations at next leveling pad steps.

- (d) *Block Facing.* An overall negative batter (wall face leaning outward) between bottom and top of wall is not allowed. The final wall face shall be vertical, or have a positive batter if required on the Construction Plans. The surface of wall face shall be tested with a 10' straightedge laid along the surface in all directions. Except for walls or sections of walls designed with horizontal curvature, the maximum deviation from the straightedge shall be less than 1/2".

Unless otherwise noted, all blocks shall be dry stacked and placed with each block spanning the joint in the row below (running bond). For walls without a rail anchoring slab, the top two courses, or a cast-in-place reinforced concrete cap course and the course directly below it, shall be internally grouted together or adhered with an adhesive approved by the block manufacturer.

For walls with rail anchoring slabs, top of block elevations shall be within 2" of the bottom of the anchoring slab or as designated in the plans. Cast-in-place concrete or sawcut partial height blocks may be used to accomplish this without extra cost to the project.

- (e) *Impervious membrane.* For all roadway-supporting walls an impervious membrane shall be installed at the top of the reinforced zone to intercept surface runoff and salt penetration. This membrane shall have a minimum coverage length measured perpendicular to the wall face at least equal to the wall design height plus 3'. The membrane shall be provided with a perforated slotted PVC or corrugated HDPE drainage collection pipe, with a geotextile sock filter, and shall extend either to the drainage system or drain out of the wall at every 100' along the wall alignment
- (f) *Manufacturer's Representative.* For alternative wall construction the Contractor shall arrange for a technical representative from the wall system supplier to be present during the construction of the MSE walls. The representative shall provide all necessary

instructions and guidelines to construct the walls in accordance with these specifications and the manufacturer's requirements. The alternative wall supplier's technical representative shall certify in writing that the wall has been constructed in accordance with the Manufacturer's product specific requirements.

504.04 Method of Measurement.

ADD THE FOLLOWING PARAGRAPH TO THE END OF SUBSECTION 504.04

The materials and labor for MSE retaining walls will be paid as complete in place, including leveling pad, block facing, reinforcement of soil, structure excavation and structure backfill. The pay area will be the area of the MSE blocks measured in square feet using the wall front face.

504.05 Basis of Payment.

ADD THE FOLLOWING TO THE END OF SUBSECTION 504.05

The accepted quantity will be paid for at the contract unit price per unit of measurement for the pay item listed below:

Payment will be made under:

Pay Item	Pay Unit
Mechanically Stabilized Earth Retaining Wall (complete in place)	Square Foot

Payment will be full compensation for designated materials and labor including all miscellaneous items necessary to construct concrete block facing MSE walls. Drainage pipes, splash blocks, expansion joint material, filter material, grouts, pins, shimming material, will not be measured or paid for separately but shall be included in the pay item.

Payment Reduction. A dislocated block is an individual block located outward more than 1/8" or placed with a vertical joint more than 1/4" from the adjacent blocks. A cracked block is an individual block with a through crack with a width of more than 1/8". A corner knock-off is a block with any missing facial corners. In the completed wall, or completed portion of the wall if, the number of defective blocks (cracked blocks, corner knock-off blocks, dislocated blocks, and substandard blocks), blocks associated with negative batter, and blocks failing the straightedge test exceeds 3% of the total number of blocks in a 6 meter (20') horizontal length of wall, a 3% price reduction will be applied for that 6 m (20') portion of wall for each one percent of defective blocks exceeding 3% to a maximum reduction of 21%. The overall percentage calculated from the sum of all defective blocks to the total blocks shall be calculated and serve as the base for the payment reduction. When the number of defective blocks and/or dislocated blocks as defined above exceeds 10% of the total, the Engineer shall reject the wall or portions thereof.

SECTION 601 - STRUCTURAL CONCRETE

601.02 Classification.

ADD THE FOLLOWING:

Concrete for construction of curbs, gutters, sidewalks, curb ramps, driveway approaches, corner fillets, drainage pans, median cover and trails shall be CDOT Class B modified as follows and shall be designated as Class GV-B (Class B modified for the Grand Valley).

- Minimum field compressive strength ----- 4000 p.s.i. at 28 days
- Air content ----- 6% ± 1.5% (see Section 601.08 for air content adjustment in the delivery truck)
- Maximum water cement ratio -----0.45
- Maximum slump at delivery shall be 4". In the event that the concrete slump from the first truck of the day exceeds 5" the load will be rejected. Subsequent batches shall be adjusted so that the slump at delivery does not exceed 4".

601.03 Materials.

ADD THE FOLLOWING:

Calcium chloride shall not be used in any concrete. See Section 711.03 for approved accelerating admixtures. Concrete shall be made with ASTM C150 Type II Portland Cement unless otherwise specified or approved by the Engineer.

601.07 Mixing.

REPLACE THE FIRST SENTENCE OF THE SECOND PARAGRAPH OF SECTION (C) 3. *TRUCK MIXING* AS FOLLOWS:

When water is added at the delivery site to control the consistency of the concrete as specified in subsection 601.02, the concrete shall be mixed for at least 40 revolutions of the mixer drum at mixing speed for each addition of water before discharge.

601.17 Acceptance and Pay Factors:

ADD THE FOLLOWING:

The results of all air and slump tests and compressive strength tests (cylinder breaks) shall be reported to the contractor and the Engineer within 24 hours after the cylinders are broken.

SECTION 602 - REINFORCING STEEL

602.08 Basis of Payment

ADD THE FOLLOWING:

Dowel bars, tie bars and reinforcing steel required in curb, gutter, sidewalk, drainage pans, fillets and concrete pavement will not be measured or paid for separately, but shall be included in the Work.

SECTION 603 - CULVERTS AND SEWERS

DELETE AND REPLACE WITH:

Culverts, storm drains, sanitary sewers, water lines, irrigation systems and underdrains shall be furnished, installed and paid for in accordance with the ***City of Grand Junction Standard Specifications for Construction of Underground Utilities.***

SECTION 604 - MANHOLES, INLETS, AND METER VAULTS

DELETE AND REPLACE WITH:

Manholes, storm drain inlets, meter vaults and other underground structures shall be furnished, installed and paid for in accordance with the ***City of Grand Junction Standard Specifications for Construction of Underground Utilities.***

SECTION 608 - SIDEWALKS AND BIKEWAYS

CHANGE THE TITLE OF THIS SECTION TO:

SECTION 608 - CURBS, GUTTERS, SIDEWALKS AND TRAILS

608.01 Description.

DELETE AND REPLACE WITH THE FOLLOWING:

This work consists of the construction of concrete trails, curb ramps, intersection corners, corner fillets, driveway sections, drainage pans, curbs, gutters, sidewalks, and bituminous curbs in conformity with the lines and grades shown on the plans or established by the Engineer.

608.02 Materials.

DELETE AND REPLACE WITH THE FOLLOWING:

Materials shall meet the following requirements:

Bed Course Material course	703.03, Class 6 aggregate base
Reinforcing Steel	709.01
Color	711.03
Concrete	Class GV-B*
Concrete for exposed aggregate surface treatment	610.02
Curing Retardant	610.02
Cure & Seal Compounds	711.01
Calcium Chloride	711.03
Evaporation Retardant	711.03
Retardant for exposed aggregate surface treatment	711.03
Joint Sealant with Backer Rod	705.01 (a)
Preformed Joint Filler	705.01 (b)

* Concrete for construction of curbs, gutters, sidewalks, curb ramps, driveway approaches, corner fillets, drainage pans, median cover and trails shall be Class GV-B conforming with Section 601.02 unless otherwise specified or approved by the Engineer.

Concrete mixes will be subject to sampling and testing at the batch plant or at the job site for compliance with the mix design and specifications.

Bituminous mixes for curbs and trails, where specified, shall be constructed of hot mix asphalt conforming to the requirements of Section 401.

CONSTRUCTION REQUIREMENTS

608.03 Concrete Sidewalks and Bikeways.

CHANGE THIS SUBSECTION TITLE TO:

608.03 Concrete Curb, Gutter, Sidewalks and Trails.

(a) *Excavation.*

ADD THE FOLLOWING:

The subgrade under all concrete shall be adjusted to optimum moisture content and uniformly compacted to no less than 95 percent of the maximum density determined in accordance with AASHTO T-99. Bed course material shall be placed on the prepared subgrade to the dimensions shown on the standard drawings and compacted to a minimum of 95 percent of the maximum density determined in accordance with AASHTO T-180.

(b) *Forms.*

ADD THE FOLLOWING:

Where concrete curbs, gutters, curb and gutter sections, drainage pans or fillets are to be removed and replaced adjacent to asphalt pavement, the existing pavement edge shall be protected from damage and used as a face form for the new concrete. Where the asphalt pavement edge is irregular, depressed below the concrete grade or built up over 1/2 inch above the concrete elevation, then the pavement shall not be used as a form and shall be cut back to make room for concrete forms in accordance with Section 401.04.14, Patching.

The forms shall be securely set to provide the section, surface, elevations and grades shown on the plans or otherwise specified. When in place, the forms shall at no point deviate more than one-fourth inch from a straight edge or tight string line.

The forms shall be left in place until the concrete has set sufficiently so they can be removed without injury to the concrete structure.

(c) *Placing Concrete.*

ADD THE FOLLOWING:

The concrete shall be thoroughly consolidated which shall be achieved by tamping and spading, vibrating or other acceptable methods.

Concrete shall not be placed on frozen ground or on frozen bed course.

(d) *Finishing.*

ADD THE FOLLOWING:

No water shall be placed on concrete surfaces during finishing operations. The Contractor shall keep plastic sheeting or other waterproof covering available on the job site to cover and protect the surface of freshly placed concrete against rain and/or dust storms.

Surface finishing shall be minimized to prevent dilution and weakening of the concrete mixture at the surface. Finishing with steel trowels shall not be allowed.

It shall be the Contractor's responsibility to protect new concrete against vandalism, vehicular damage and defacement of any kind until it has been accepted by the City. All damaged or defaced concrete shall be repaired or replaced, as directed, at the Contractor's expense.

When during concrete finishing operations, the air temperature, relative humidity and wind velocity result in an evaporation rate of 0.2 lb/ft²/hr or above, an approved evaporation reducer (see Subsection 711.03) shall be applied to the concrete surface to help prevent plastic shrinkage cracks. The evaporation rate can be determined from an evaporation chart published in ACI 305R. When an evaporation retarder is used, the concrete shall not be worked or finished until all water within the retarding admixture has evaporated from the surface.

(e) *Joints.*

DELETE AND REPLACE WITH THE FOLLOWING:

Control joints shall have the same meaning as contraction joints. Construction joints referred to in subsection 608.03(e) of the CDOT Standard Specifications shall have the same meaning as isolation joints.

Transverse expansion joints shall be placed in curb, gutter and sidewalk at both ends of intersection radii and at other locations shown on the plans. The maximum spacing of expansion joints in continuous curb, gutter and/or sidewalk shall be 500 feet.

Isolation joints shall be placed around all appurtenances such as manholes, utility poles, sign posts, etc. and between new concrete and any fixed structure such as a building or bridge. Isolation joints and expansion joints shall be formed with preformed joint filler conforming to AASHTO M 213 unless otherwise specified or approved. Preformed joint filler shall be extended to the full depth of the concrete section and be set or trimmed to ½ inch below the finished surface. All expansion and isolation joints shall be sealed in accordance with the detail shown in the Standard Concrete Details.

Curb, gutter and sidewalk shall be divided into uniform sections by forming contraction joints with a jointing tool, or by saw cutting after the concrete has hardened. Contraction joints in trails and detached sidewalks shall be made by saw cutting or with preformed plastic strips.

Contraction joints shall extend into the concrete at least $\frac{1}{4}$ of the depth of the concrete and shall be $\frac{1}{8}$ to $\frac{1}{4}$ inch wide. Joints shall be spaced at intervals of ten (10) feet unless otherwise specified or approved. Where the length of a pour precludes even ten-foot joint spacing, the end section(s) may be less than (10) ten feet but not less than (5) five in length. Sawed joints shall be installed immediately after the concrete has hardened and before irregular shrinkage cracks form in concrete. When contraction joints are saw cut, hand tooled contraction joints shall be installed at intervals not to exceed (50) fifty feet to prevent shrinkage cracking before the remaining joints are cut.

Where new concrete is placed adjacent to existing concrete the joint type and spacing shall match to those in the existing concrete.

(f) *Curing.*

DELETE AND REPLACE WITH THE FOLLOWING:

Immediately after finishing, the Contractor shall apply two coats of an approved membrane forming curing compound (see subsection 711.01) to all exposed concrete surfaces. If the surface is dry, the concrete shall be thoroughly wet with water and the curing compound applied just as the surface film of water disappears. The rate of application of curing compound shall be in accordance with the manufactures recommendations but not less than the amount necessary to uniformly coat all exposed surfaces. Additional coats of curing compound shall be applied until all streaked or blotchy areas have been covered. If the curing membrane is marred, removed or otherwise damaged within ten days after application, an additional coat of curing compound shall be applied to all damaged areas. When forms are removed within ten days after the concrete is placed, curing compound shall be immediately applied to all exposed concrete surfaces.

Whenever the ambient temperature drops below 40°F, application of curing compound shall be stopped and the *Blanket Method* described below shall be used.

All concrete placed between October 1 and March 31 and at any other time when the ambient temperature is expected to drop below 40° F during the *curing period*, shall be cured in accordance with Section 601.13 (d) *Blanket Method* unless otherwise specified or approved by the Engineer. Blankets shall be placed immediately after the concrete has been finished and the surface has set.

After the first 24 hours of curing, the insulation blankets shall be removed to check for water on the surface of the concrete. If water is present, it shall be removed by blotting with clean cloth or other approved method. The blankets shall be replaced immediately after the water has been removed. The concrete surface shall be checked for water and any water found shall be removed once each day until no more water collects on the surface.

The temperature of the concrete shall be monitored using an electronic sensing device or a low temperature recording thermometer placed between the concrete surface and the insulated blanket(s). If the temperature at the surface of the concrete cannot be maintained above 40°F using the *Blanket Method*, then enclosures with artificial heat sources shall be installed. If enclosures are used the Contractor shall monitor and maintain the structural integrity of the enclosure. Sufficient space shall be provided between the concrete and the enclosure to permit free circulation of the warmed air. Heaters and ducts shall be positioned so as not to cause overheating or drying of the concrete surface. During *the curing period*, concrete surfaces shall not be exposed to air at more than 75°F. Combustion heaters shall be vented type heaters that have a heat exchanger in the fire box so that exhaust gases are vented to the outside atmosphere. At the end of the curing period, the protection shall remain in place until it can be removed without permitting the concrete temperature to fall more than 50° in a 24 hour period. Sudden changes in temperature shall be prevented.

When insulation blankets or heated enclosures are required to maintain the temperature at the concrete surface above 40 °F, the minimum *curing period* shall be 120 hours from the time the concrete is placed or until the concrete has reached a compressive strength of 80 percent of the required field compressive strength. The compressive strength of the curing concrete shall be estimated in accordance with one of the following methods:

Information Cylinder Method:

If a shorter curing period is desired, the Contractor may submit a modified concrete mix design for review and approval by the Engineer. Methods of achieving earlier strength and decreasing curing time include increasing the cement content of the mix and/or use of approved admixtures. The Contractor shall cast a set of at least six (6) information cylinders from the final load of concrete placed each day for each mix used. The information cylinders shall be cast by an ACI Certified Concrete Field Technician in accordance with AASHTO T-23 and stored as close to the concrete placement as possible. The information cylinders shall receive similar thermal protection as the in-place concrete. The contractor shall protect the information cylinders from damage. The compressive strength of the Information cylinders shall be determined by an ACI Certified Laboratory Testing Technician in accordance with AASHTO T-22. The insulation blankets can be removed from the concrete when the average compressive strength of two information cylinders, broken consecutively, is greater than or equal to 80 percent of the required field compressive strength.

Maturity Method:

The Contractor shall develop a strength vs. maturity relationship for each concrete mix design, including admixtures, to be used in the project. Cylinders used to develop the strength vs. maturity curve(s) shall be cast and cured in accordance with ASTM C 1074 or subsection 412.15 in the CDOT Standard Specifications. The Contractor shall provide the maturity meter, data- loggers or other approved apparatus required to monitor and record the concrete temperature as a function of time. The Contractor shall place, protect and maintain the temperature logging devices at locations designated or approved by the Engineer. The logging devices shall be capable of recording the concrete temperature at intervals of ½ hour or less for the first 48 hours and 1 hour or less thereafter. A minimum of one temperature logging device shall be embedded in the concrete for each mix placed, each day.

City of Grand Junction, Colorado
Standard Specifications for Road and Bridge Construction

Accelerating admixtures, if used, shall be included in the concrete used to develop the strength - maturity curves at the same percentage that will be used in concrete placed in the project. Accelerating admixtures shall be a non-chloride type conforming to ASTM C 494, Type C. Approved accelerating admixtures are listed in subsection 711.03. Dosages of admixtures shall not exceed the manufactures recommendations.

Potential Frost Damage. If the temperature of the concrete or the air temperature at the concrete surface falls below 32° at any time during the *curing period*, the concrete shall be tested for frost damage in accordance with Subsection 601.13 (e).

Vehicular traffic shall not be allowed on new concrete until 5 days after placement or until the concrete reaches a compressive strength greater than or equal to 80 percent of design strength.

ADD THE FOLLOWING PARAGRAPHS:

- (g) *Backfilling.* After the concrete has set sufficiently, and forms have been removed, the spaces adjacent to the concrete curb, sidewalk, or path shall be immediately backfilled to the required elevation with specified or approved materials.
- (h) *Concrete Extrusion Machine.* Concrete curbs, gutters, sidewalks, paths or combinations of these sections may be constructed by the use of an extrusion machine. Machine placed concrete shall be jointed, cured and backfilled as specified herein.
- (i) *Surface Tolerance.* Concrete shall be finished to a smooth and uniform surface, which shall at no point deviate from plan elevation more than one-fourth ($\frac{1}{4}$) inch. On sidewalks and paths, no low spots or depressions shall be detectable when tested with a straight edge laid transverse to the longitudinal centerline. Sections of sidewalk on which water ponds or does not drain from the surface, shall be removed and replaced at the Contractor's expense. The face and top of curbs and flowline of gutters shall not deviate more than $\frac{1}{4}$ inch from a 10 ft. straight edge laid longitudinally along the concrete surface. The City Project Engineer and/or the Construction Inspector shall determine where surface tolerance testing is required. If testing is required, the Contractor shall furnish an approved 10 ft. straight edge and provide an operator to assist the Inspector. Surface tolerance shall be measured at all locations designated by the Inspector.
- (j) *Detectable Warnings.* Detectable warnings shall be installed on new curb ramps and other locations where pedestrian ways blend with vehicular ways without tactile cues. Detectable warning surfaces shall consist of raised truncated domes with a diameter of nominal 0.9 in (23 mm), a height of nominal 0.2 in (5 mm) and a center-to-center spacing of nominal 2.35 in (60 mm). The domes shall be "in line" both parallel and perpendicular to the ramp to form a square grid pattern. The detectable warning shall contrast visually with adjoining surfaces, either light-on-dark, or dark-on-light. The domes and the underlying surface shall have a minimum of 70% contrast with the light reflectivity of the adjoining surface. Detectable warning surfaces shall extend 24 inches in the direction of pedestrian travel and shall match the width of the curb ramp (48" typical), landing or blended transition. The detectable surface shall be located so that the edge nearest the roadway is 6 inches minimum and 8 inches maximum from the face of curb line or from

the edge of roadway where there is no curb.

An approved detectable warning plate or panel shall be “wet set” into the surface of freshly placed concrete during construction of each new curb ramp. Detectable warnings may be attached to the surface of hardened concrete only when retrofitting pre-existing curb ramps or when otherwise approved by the Engineering Manager.

The following detectable warning systems are approved for use in new curb ramp construction:

- Cast iron detectable Warning Plates manufactured by East Jordan Iron Works (800) 626-4653 or Neenah Foundry Company (303) 809-6315
- Cast iron detectable warning plates SWP2424 and SWP1224 furnished by Castings Inc. (970) 243-2032
- Replaceable Composite (wet-set) Tactile manufactured by ADA Solutions, Inc. (800) 372-0519
- ADA Replaceable Tiles manufactured by ADA Replaceable Tiles (970) 245-3400
- Polymer concrete detectable warning devices manufactured by ACO(800)543-4764
- MetaDome MDMetaPanel[®] MD60 or stainless steel manufactured by MegaDome LLC (877) 270-3663
- Detectable Warning Paving Slabs manufactured by StoneBilt Concepts (303) 867-6700

The following products are approved for retrofitting pre-existing curb ramps with surface applied detectable warnings:

- Armor-Tile Ridged Plastic Mat manufactured by Engineered Plastics distributed by White Cap Construction Supplies (970) 245-6787
- Surface Mount Composite Tactile manufactured by ADA Solutions, Inc. (800) 372-0519
- USA Safety Domes, Surface Mount System (800) 540-9277
- MetaDome MetaPanel[®] weathering steel (MD60) or stainless steel manufactured by MegaDome LLC (877) 270-3663

All other detectable warning types, materials and manufacturers shall be approved by the City’s Engineering Manager prior to installation.

All detectable warnings, except cast iron plates, shall be brick red in color. Detectable warnings shall be installed in accordance with the manufacturer’s instructions and the City of Grand Junction Standard Concrete Detail C-23.

608.04 Bituminous Sidewalks and Bikeways.

ADD THE FOLLOWING PARAGRAPH:

- (d) *Bituminous Curb.* Bituminous curb shall be constructed in accordance with subsection 609.05 of the *CDOT Standard Specifications*. Bituminous curb, trails, bikeways and sidewalk shall be installed only where designated on the plans or directed and shall not be used in place of concrete curb or sidewalk.

608.05 Method of Measurement.

DELETE AND REPLACE WITH THE FOLLOWING:

Concrete items of the various types and sizes specified will be measured by the linear foot or square yard. Linear measurement of monolithic curb and gutter and monolithic curb, gutter and sidewalk will be made along flow-line of the gutter.

The pay item for "Concrete Intersection Corner" shall include payment for the corner fillet (if any), curb, gutter, sidewalk, landings and curb ramp. The Concrete Intersection Corner shall extend from the beginning to the end of the of the curb arc.

The pay item for "Detectable Warning" shall include full compensation for furnishing and installing an approved detectable warning system on an existing or new curb ramp.

When concrete items are paid for by the square yard or square foot, the area to be paid for shall be based on the actual dimensions of the approved items measured in a horizontal plane.

608.06 Basis of Payment. DELETE AND REPLACE WITH THE FOLLOWING:

The accepted quantities will be paid for at the contract unit price for each of the pay items listed below that appear in the bid schedule.

Payment will be made under:

Pay Item	Pay Unit
Concrete Curb (___" wide, ___" high)	Linear Foot
Concrete Curb and Gutter (___' wide)	Linear Foot
Concrete Drive Over Curb and Gutter (___' wide)	Linear Foot
Concrete Curb with Spill Gutter (___' wide)	Linear Foot
Monolithic Vertical Curb, Gutter and Sidewalk (___' wide)	Linear Foot, Square Yard
Monolithic Drive Over Curb, Gutter and Sidewalk (___' wide)	Linear Foot, Square Yard
Monolithic Curb, Gutter and Sidewalk (any curb type)	Linear Foot, Square Yard
Concrete Sidewalk (___" thick)	Square Yard
Concrete Bikeway (___" thick)	Square Yard
Concrete Driveway Section (___" thick)	Square Yard
Concrete Drainage Pan (___' wide)	Square Yard
Concrete Corner Fillet	Square Yard
Concrete Curb Ramp	Square Yard
Concrete Intersection Corner	Square Yard
Detectable Warning (surface applied)	Square Foot
Detectable Warning (wet set)	Square Foot
Bituminous Sidewalk (___" thick)	Square Yard
Bituminous Bikeway (___" thick)	Square Yard
Bituminous Curb (___" wide, ___" high)	Linear Foot

City of Grand Junction, Colorado
Standard Specifications for Road and Bridge Construction

Colored Concrete _____ (____" thick)	Square Yard
Colored Concrete _____ with exposed aggregate (____" thick)	Square Yard
Concrete _____ with exposed aggregate (____" aggregate) (____" thick)	Square Yard
Colored, Patterned Concrete _____ (____" thick)	Square Yard
 Sidewalk Drain Trough	 Linear Foot

The contract unit prices for the various concrete items shall be full compensation for all equipment, labor, materials, and incidentals required for the complete installation. The following items shall be considered incidental to the various concrete items and will not be measured or paid for separately: sub-grade preparation, aggregate bed course material, saw cutting joints, cure & seal compounds, evaporation reducing agent, joint filler, waterproof sheeting, tie bars, dowel bars, reinforcing steel and insulating blankets or heating required for curing concrete in cold weather.

SECTION 609 - CURB AND GUTTER

DELETE THIS SECTION EXCEPT FOR SUBSECTION 609.05 BITUMINOUS CURB. SPECIFICATIONS FOR THE CONSTRUCTION OF CONCRETE CURB AND GUTTER ARE INCLUDED IN SECTION 608.

SECTION 610 – MEDIAN COVER MATERIAL

MATERIALS

ADD THE FOLLOWING TO SUBSECTION 610.02

Concrete mixes for exposed aggregate surface treatment shall meet the following requirements unless otherwise approved:

3/4" Coarse Aggregate:

Cementitious Material (cement plus fly ash) -----	565 lb. per cu. yd.
Concrete Sand -----	35 to 37 percent
Coarse Aggregate (3/8" to 3/4") -----	63 to 65 percent
Air content -----	4.5 to 7.5 percent
Slump -----	4 inch maximum

3/8" Coarse Aggregate:

Cementitious Material (cement plus fly ash) 565 lb. per cu. yd.	
Concrete Sand -----	40 to 45 percent
Coarse Aggregate (1/8" to 3/8") -----	55 to 60 percent
Air content -----	4.5 to 7.5 percent
Slump -----	4 inch maximum

Maximum fly ash content shall be 20% of cement content by weight.

Color additive and curing/sealing compound for colored concrete shall be manufactured by DAVIS Colors, 3700 E. Olympic Blvd., Los Angeles, CA or an approved equal.

Concrete curing retardant (for exposed aggregate finishes) shall be PRECO ASC-S Regular Concrete Retardant or a approved equal.

Isolation Joint Material shall be ½ inch wide preformed joint filler with void cap conforming to AASHTO M-213.

Joint sealant shall be polyurethane conforming to ASTM C-920, NPI or Silicone conforming to Subsection 705.01 of CDOT Standard Specifications. Sealant shall be same color as concrete.

ADD THE FOLLOWING TO SUBSECTION 610.03 (B)

Exposed aggregate concrete finish shall be obtained by applying curing retardant to the finished concrete surface in accordance with the retardant manufacture's recommendations. The cement matrix shall be removed to a depth not to exceed 1/3 of the maximum size aggregate. Water used to wash the curing retardant and cement/sand matrix from the concrete surface shall not be allowed to enter any storm drain, sewer or surface waters. The contractor's plan for collection and disposal of the wash water shall be approved by the Engineer prior to placing concrete.

City of Grand Junction, Colorado
Standard Specifications for Road and Bridge Construction

Isolation joints shall be placed between curbing and median cover material and at other locations described in Subsection 608.03 (d) or shown on the plans. Isolation joints shall be sealed with an approved sealant. Transverse contraction joints shall be saw cut to $\frac{1}{4}$ of the concrete thickness at uniform spacing not to exceed 10 feet. Contraction joints shall not be sealed unless otherwise shown on the plans of specified.

REPLACE THE PAY ITEMS UNDER SUBSECTION 610.05 AS FOLLOWS:

Pay Item	Pay Unit
Median Cover Material (Bituminous)(____" thick)	Square Yard
Median Cover Material (Concrete)(____" thick)	Square Yard
Median Cover Material (Colored Concrete)(____" thick)	Square Yard
Median Cover Material (Patterned Concrete)(____" thick)	Square Yard
Median Cover Material (Patterned, Colored Concrete)(____" thick)	Square Yard
Median Cover Material (Concrete, Exposed Aggregate Finish) (____" coarse aggregate) (____" thick)	Square Yard
Median Cover Material (Colored Concrete, Exposed Aggregate Finish) (____" thick)	Square Yard
Median Cover Material (____" Cobble Rock)(____" thick)	Square Yard
Median Cover Material (Bark Mulch) (____" thick)	Square Yard
Median Cover Material (_____) (____" thick)	Square Yard

SECTION 619 - WATER LINES

DELETE THIS SECTION AND REPLACE WITH THE FOLLOWING:

Water lines and appurtenances shall be constructed in accordance with the ***City of Grand Junction Standard Specifications for Construction of Underground Utilities.***

SECTION 625 - CONSTRUCTION SURVEYING

DELETE SECTION 625 OF THE CDOT STANDARD SPECIFICATIONS AND REPLACE WITH THE FOLLOWING:

625.01 Description. This work consists of the construction surveying, calculating, and staking necessary for the construction of all elements of the project and preparing "As Built" drawings. The work shall be done under the supervision of a Professional Land Surveyor (PLS) who is experienced and competent in road and bridge construction surveying and licensed in the State of Colorado. Referencing, setting and restoring land monuments and the determination of land lines shall be in accordance with Section 629. The PLS shall be available to review work, resolve problems and make decisions in a timely manner.

625.02 Materials and Equipment. The Contractor shall furnish all personnel, materials, equipment and traffic control necessary to perform the required construction surveying. All surveying equipment, including electronic distance meters, tapes, tribrachs, theodolites, total stations, GPS receivers, and levels shall be calibrated prior to the start of work. EDM's, total stations and GPS receivers shall be checked on a calibrated baseline. Traffic Control shall be in accordance with the Manual on Uniform Traffic Control Devices.

625.03 Construction Requirements.

General. The City or owner's Surveyor shall establish horizontal and vertical control for each project. It is the Surveyor's responsibility to check and verify all previously established control points (both horizontal and vertical) prior to commencement of the survey/construction work. The Surveyor must document these checks and notify the Project Engineer or City Surveyor of any discrepancies prior to using these points.

Vertical control points (bench marks) shall be located outside the area of construction whenever possible. A minimum of two (2) benchmarks are required for each project and they shall be located no more than 100 feet from the project. Spacing between bench marks shall not exceed 500 feet throughout the length of the project.

Horizontal control points shall be located outside the area of construction whenever possible. A minimum of two (2) inter-visible (visible from one to another) horizontal control points are required for each project, one of which shall be located no more than 100 feet from the project. Each control point shall have 'line of sight' to at least one other control point. Spacing between horizontal control points shall not exceed 700 feet throughout the length of the project.

625.04 Contractor Surveying. Unless otherwise specified or approved, the Contractor's Surveyor shall perform all construction surveying and staking that is necessary for construction of the project. Construction surveying and staking shall be based on established survey control. Stationing, if not previously established, shall be located in the field along the centerline or an approved offset.

625.05 Staking. Staking intervals for construction surveying shall be such that the work can be efficiently and accurately completed. Staking shall be referenced to the horizontal and vertical control as shown on the plans or as provided by the City. Offset stakes, if used, shall be clearly marked with the offset distance and other pertinent information. The Surveyor's grade sheets shall be submitted to the Construction Inspector as the project is staked.

625.06 Accuracy and Tolerances. Accuracy of surveys and survey tolerances shall be as specified by the State of Colorado statutes pertaining to surveying.

625.07 Responsibility and Inspection. Supervision and coordination of construction surveying is the Contractor's responsibility. The City may review or inspect the Contractor's surveying, however, such inspection will not relieve the Contractor of any responsibility for accuracy or completeness of work. The Contractor shall check the work to verify the accuracy and include documentation of this check in the survey records. All Contractor surveying inaccuracies, errors, or omissions shall be corrected at the Contractor's expense. The Engineer's checking of the Contractor's corrections shall not entitle the Contractor to additional payment or contract time extension.

625.08 Reset Controls and Stakes. Control points, benchmarks and construction stakes that are damaged, destroyed or made inaccessible shall be replaced, transferred or re-established at the Contractor's expense. Points identified as control monuments, right-of-way monuments, property pins and all other monuments that are required by law or regulation to be established and recorded by a PLS shall be reset in accordance with Section 629.

625.09 Changes. All changes in lines and grades required by field conditions and all discrepancies in grades, alignment, location or dimensions detected by the Contractor shall be immediately submitted to the Engineer in writing. No changes in given data or plans will be allowed unless authorized by the Engineer in writing. All changes shall be documented in survey records.

625.10 Pay Quantity Measurements. The City will perform cross-section surveying to determine excavation and embankment quantities when payment is based on field measurement. All other measurements for interim and final pay quantities shall be jointly performed and agreed to by the Contractor and the City. The Contractor's Surveyor shall establish and maintain control points and stationing as required for these measurements.

625.11 Survey Records. Unless otherwise approved by the Engineer, survey records shall be completed as the work is done. Field notes for construction surveying and checking by the Contractor shall be recorded in survey records in conformance with accepted industry practice. If an electronic format is used, it shall contain the same information and format as required in the **CDOT** Survey Manual.

Initial staking for major structures (overhead signs, concrete box culverts, bridges, and all other structures) shall be done from two independent setups. An independent check shall be made by the Contractor's Surveyor and shown in the survey records for all bridge structures.

All survey records generated on City managed projects shall be the property of the City and shall be available to the Engineer for inspection or reproduction at all times. All survey records shall be transmitted to the Engineer for inclusion into the project records before final project acceptance. All survey records shall be stamped with the seal of, and signed by the responsible PLS identified in subsection 625.01.

625.11a As-Built Drawings. The Contractor's Surveyor shall prepare and maintain an up-to-date set of As-Built drawings in accordance with Section VI, paragraph 54 of the General Contract Conditions. For all newly constructed pipeline, appurtenances, and structures, inverts in and out of structures, and the center of top of structures, shall be surveyed vertically and

City of Grand Junction, Colorado
Standard Specifications for Road and Bridge Construction

horizontally to the nearest 0.01 foot, and all pipe fittings, such as bends located vertically to the nearest 0.10 foot and horizontally to the nearest 1.0 foot. Furthermore, where newly constructed pipeline crosses other pipelines or utilities, the top of the lower and bottom of the higher pipe or conduit shall be surveyed to the nearest 0.10 foot. The pipe elevations, along with the northing and easting coordinates in accordance with the plan datum and baseline coordinates, shall be recorded on the As-Built drawings. On City managed projects, As-Built information shall be neatly written or drawn in red ink on a clean blue line plan set and submitted to the Project Engineer. In addition to the above, As-Built drawings for private development projects shall be prepared and submitted in accordance with requirements of the City's SSID Manual.

625.12 Method of Measurement Construction surveying will not be measured but will be paid for on a lump sum basis.

625.13 Basis of Payment Construction surveying will be paid for at the lump sum bid contract price and will be full compensation for all surveying work necessary to complete the project, as shown on the plans, including all setting and resetting of stakes, marks and control points, and preparation of As-Built (record) drawings..

Construction surveying required by force account or by additional work beyond the scope of the original Contract will be paid for at a rate to be negotiated prior to the work. Any survey work not performed to the contract requirements shall be subject to price reduction or rejection. Partial payment for construction surveying, as approved by the Engineer, will be made as the work progresses.

Payment will be made under:

Pay Item	Pay Unit
Construction Surveying	Lump Sum

Traffic control for construction surveying will not be measured or paid for separately but shall be included in the work.

SECTION 626 - MOBILIZATION

DELETE AND REPLACE SUBSECTION 626.02 AS FOLLOWS:

Payment for mobilization will be based on the percentage of personnel and equipment that has been mobilized at the end of each pay period, as agreed to by the Engineer and the Contractor.

Payment will be made under:

Pay Item	Pay Unit
Mobilization	lump Sum

SECTION 629 - SURVEY MONUMENTATION

629.01 Description.

DELETE AND REPLACE THE LAST PARAGRAPH AS FOLLOWS:

Unless specified otherwise in the Contract, all survey procedures shall be in conformance with national, State and local laws, statutes and ordinances regarding land surveying and including but not limited to local standards of practice.

629.02 Materials.

DELETE AND REPLACE AS FOLLOWS:

The Contractor shall furnish all labor, tools, equipment and materials including but not limited to monument boxes, concrete, grout, asphalt caulk, glue, epoxy, nails, stakes and lath required to install or replace survey monuments.

All surveying equipment, including electronic distance meters (EDM), total stations, theodolites, levels, rods, tapes, tripods, tribrachs and global positioning system (GPS) receivers and associated equipment, shall be checked for accuracy and calibrated if required.

The type, make and model of any survey equipment used in the performance of the project, such as EDM's, total stations, theodolites and global positioning systems (GPS) shall be duly noted and recorded in the surveying records of the project, and furnished to the Engineer and City Surveyor.

CONSTRUCTION REQUIREMENTS

629.03 General.

DELETE AND REPLACE THE SECOND PARAGRAPH AS FOLLOWS:

The Contractor's Surveyor will attend all pre-survey and/or pre-construction conferences that the City determines to be necessary either prior to or during construction.

DELETE AND REPLACE THE SIXTH PARAGRAPH AS FOLLOWS:

If an electronic format is used the printout shall be signed and sealed by the PLS in responsible charge and shall be submitted to the Engineer with a 3-½ inch floppy disk or CD which contains the stakeout data and the raw data from the actual monument placement in a format compatible with that of the City.

ADD THE FOLLOWING:

The PLS shall coordinate all aliquot monument survey work with the Mesa County Surveyor and the City Surveyor. Monument records shall be filed with the State as mandated by statutory requirements.

629.04 Location Monuments

ADD THE FOLLOWING:

Unless otherwise specified, the City will record in its survey records, all survey monuments, including property corners, that were located, found or used by the City while establishing survey control and in the performance of other pre-construction surveys. These survey records will be provided to the Contractor or the PLS upon request. There may be additional survey monuments or property corners that were not located that lie within the limits of the project.

629.05 Preserving and Referencing Monuments.

ADD THE FOLLOWING:

The PLS shall reference all survey monuments within the limits of the project with no less than three (3) accurate horizontal ties. GPS coordinates may be obtained and will be secondary in nature to the horizontal ties in the replacement and confirmation of the relocated position.

The PLS shall submit to the Engineer a copy of all monument references ties depicting the location and description of reference points, a description of the survey monument as found and the tie distances. If GPS technology is also used, the PLS shall submit for review and approval, a copy of survey monument coordinates and methodology used to create these coordinates. Monuments shall not be disturbed until the City's Surveyor has approved the coordinates and monument references in writing.

All apparent property corners shown on the plans represent those found prior to construction. The City takes no responsibility for the accuracy of existing property pins or for property pins not shown on the plans. The Contractor and its surveyor shall preserve and maintain all apparent property pins. If any property pins are moved or destroyed during construction, they shall be reset in accordance with the laws and rules of the Board and the Colorado Revised Statutes (CRS) at the Contractor's expense.

629.06 Installing Monuments.

DELETE AND REPLACE THIS SUBSECTION AS FOLLOWS:

After construction has been completed, and before final payment is made, all disturbed, destroyed and removed survey monuments shall be replaced in accordance with State Statutes. Monuments which are destroyed by the Contractor and which are not within the scope of work shall be replaced by the Contractor at his expense.

Public land survey (aliquot) monuments shall meet the physical standards specified by law.

The PLS shall provide to the City Project Engineer a final set of horizontal monument ties for resetting survey monuments such that there are no less than three (3) accurate horizontal ties. Additionally, in the case of monuments that represent section corners, quarter corners, or sixteenth corners, the PLS shall provide monument records to the Engineer and to State of Colorado, as required by § 38-53-104, CRS.

629.07 Monument Box.

DELETE AND REPLACE THIS SUBSECTION AS FOLLOWS:

This work shall consist of installing or adjusting survey monuments and monument boxes. When it is necessary to set a monument within a monument box the work shall be done in accordance with § 38-51-102(18) CRS and the City Standard Survey Monument Box Detail. If the monument meets the physical standard as stated by the Board and is situated within a roadway, a monument box shall be installed. When an existing monument box, due to construction, will no longer meet the physical standards set by the Board, the Contractor shall replace or adjust the box as required to meet those standards.

629.09 Basis of Payment.

INCLUDE THE FOLLOWING:

The accepted quantities will be paid for at the contract unit price for each of the pay items listed that appear in the bid schedule. Locating, referencing and protecting survey monuments will not be measured or paid for separately but shall be included in the work.

All survey notes and Monument Records shall be submitted to the City Project Engineer before payment will be made for survey monuments.

The Contract price for Survey Monument (Complete in Place) shall be full compensation for all materials, labor and equipment necessary to reset or install survey monuments and monument boxes of the various types listed.

SECTION 630 - CONSTRUCTION ZONE TRAFFIC CONTROL

630.09 Traffic Control Plan.

ADD THE FOLLOWING:

If a Traffic Control Plan (TCP) is not provided in the plans, then the Contractor shall furnish one. The TCP shall be prepared in accordance with the Manual on Uniform Traffic Control Devices, latest edition. The Contractor shall submit the TCP to the Engineer for review at least two (2) Working days before the pre-construction meeting. The TCP shall consist of a drawing showing the following information:

- (a) North arrow and project name; all streets and street names in the vicinity of the project and any proposed detour routes; location and dimensions of traffic lanes, curbs, sidewalks and traffic control in the vicinity of the Work.
- (b) Layout of all proposed street and lane closures including detour routes. Show the number of days and hours per day the street and lane closures will be in effect.
- (c) The type and location of all barricades, warning signs, detour signs, cones, delineators and other traffic control devices that will be used on the project.
- (d) The location and schedules of all flag persons that will be needed.
- (e) The name(s) and phone number(s) of the Contractor's designated Traffic Control Supervisor (TCS) including persons who can be reached after working hours, and on holidays and weekends.
- (f) Any special instructions and information on how the traffic control is to be setup, changed or removed.

During the progress of the Work, if adjustments to the TCP are necessary, the Contractor shall submit a revised TCP to the Engineer for approval at least two (2) working days prior to implementation of the change(s).

At least twenty-four (24) hours prior to closing any street or roadway, the Contractor shall notify the Engineer, Police and Fire Departments, the City's solid waste Supervisor (244-1570), the private trash haulers (if applicable) the school bus company and the U.S. Postal Service. The Contractor shall make additional notifications prior to any significant change in the traffic control setup or detour routes. The Police and Fire Departments shall also be notified in advance of all traffic lane closures.

The Contractor shall furnish all traffic control devices and flag persons necessary to implement the approved TCP and any additional traffic control that Engineer determines necessary for protection of the Work and/or safety of the public.

City of Grand Junction, Colorado
Standard Specifications for Road and Bridge Construction

The Contractor shall maintain access to all private driveways at all times unless otherwise approved by the Engineer. Residents and/or property owners shall be notified by the Contractor at least forty-eight (48) hours prior to the temporary closure or relocation of street access. Access to properties in construction zones shall be maintained with a smooth gravel surface.

All traffic control devices shall be promptly removed from the roadway when they are no longer needed.

630.14 Method of Measurement.

DELETE AND REPLACE WITH THE FOLLOWING:

When Traffic Control (complete in place) is paid for by the day, it shall be measured by the number of days that the approved traffic control is authorized and maintained.

The Traffic Control Supervisor(s) will not be paid for separately but shall be included in the pay item for Traffic Control (complete in place).

Flagging will be measured by the hour for the total number of hours that flagging is authorized and performed. At the end of each day, the Traffic Control Supervisor shall submit to the Construction Inspector, a time sheet with the total number flag persons and flagging hours used that day. The number of flagging hours to be paid shall be determined from the daily time sheets. Hand devices, signs and other equipment required for flagging will not be measured or paid for separately, but shall be included in the work.

Message boards will be measured by counting the number of days that each authorized message board is operational and used.

630.15 Basis of Payment.

DELETE AND REPLACE WITH THE FOLLOWING:

Traffic Control will be paid for under the items listed in the Bid Schedule. Payment for Traffic Control (complete in place) shall include the traffic control supervisor(s) and all labor, equipment and materials (except message boards) required to furnish, set up, maintain, move, reset and remove all traffic control devices in accordance with the approved traffic control plan or as otherwise required to protect the work and assure the safety of workers and the public.

When a Traffic Control Plan is required and is not included in the project plans, then one shall be furnished by the Contractor and will be paid for at the lump sum pay item for Traffic Control Plan.

Payment will be made under:

Pay Item	Pay Unit
Traffic Control (complete in place)	Day, Lump Sum
Flagging	Hour
Traffic Control Plan	Lump Sum
Message Board (____ each)	Day

City of Grand Junction, Colorado
Standard Specifications for Road and Bridge Construction

In the event that the Contractor fails to complete the construction within the specified or authorized Contract Time and no extension of time is authorized by the City, all traffic control, flagging and traffic control supervision required thereafter will not be measured and paid for but shall be provided at the Contractor's expense.

When Traffic Control is paid for by the day, no payment will be made for working days when the Contractor's daily work force is not on the job or when no progress in the work is being made, except when the work cannot progress due to inclement weather or other conditions beyond the Contractor's control, authorized Traffic Control will be paid for.

SECTION 703 - AGGREGATES

703.07 Bed Course Material

DELETE AND REPLACE PARAGRAPH (a) AS FOLLOWS:

- (a) Bed course material for curb, gutter, sidewalks and bike/pedestrian paths shall be aggregate base course Class 6 unless otherwise approved by the Engineer.

SECTION 705 – JOINT, WATERPROOFING AND BEARING MATERIALS

705.01 Joint Fillers.

ADD THE FOLLOWING TO PARAGRAPH (a) JOINT SEALANT WITH BACKER ROD:

The following sealants are approved for sealing concrete joints:

Sika Group - Sikaflex-1c SL
Dow Corning - Dow 890-SL
Pecora Corporation - Pecora 300 SL
Tremco incorporated - Spectrem 900-SL
Sonneborn – Sonalastic SL1

The color of the joint sealant shall match the color of the concrete unless otherwise specified or approved.

ADD THE FOLLOWING TO PARAGRAPH (b) PREFORMED JOINT FILLERS:

Preformed joint fillers conforming to AASHTO M 153 Type IV – Polyurethane bonded recycled rubber, are approved.

SECTION 711 - CONCRETE CURING MATERIALS AND ADMIXTURES

711.01 Curing Materials.

ADD THE FOLLOWING:

Liquid membrane-forming curing compound shall be a V.O.C. compliant, dissipating resin, conforming to AASHTO M-148, Type 2 for uncolored concrete or Type 1 (clear) for colored concrete. The following curing compounds are approved:

- Dayton Superior - Day-Chem White Pigmented Cure (J-10-W)
- Dayton Superior - White Dissipating Cure EF
- Euclid – Kurez DR VOX

711.03 Chemical Admixtures and Color Additive.

ADD THE FOLLOWING:

Accelerating Admixtures: Set accelerating admixtures shall be non-chloride liquid conforming the ASTM C 494 Type C. The following accelerating admixtures are approved:

- BASF Chemical Company - Pozzolith NC 534
- Grace Construction Products - Daraset 200, 400 or HES
- Euclid Chemical Company – Eucon NCA or Eucon ACN

Evaporation Retardants. The following evaporation retardants are approved:

- BASF Chemical Company - CONFILM
- Dayton Superior - Sure Film J-74
- Euclid Chemical Company - EucoBar

Color Additive for Colored Concrete shall be manufactured by DAVIS Colors, 3700 East Olympic Blvd., Los Angeles, CA or an approved substitute.

ENGINEERING DIVISION



PUBLIC WORKS
& PLANNING

STANDARD SPECIFICATIONS FOR CONSTRUCTION OF UNDERGROUND UTILITIES – WATERLINES, SANITARY SEWERS, STORM DRAINS, UNDERDRAINS AND IRRIGATION SYSTEMS

REVISED JULY, 2010

CITY OF GRAND JUNCTION, COLORADO
DEPARTMENT OF PUBLIC WORKS AND PLANNING
ENGINEERING DIVISION

**STANDARD SPECIFICATIONS FOR THE
CONSTRUCTION OF UNDERGROUND UTILITIES -
WATERLINES, SANITARY SEWERS, STORM DRAINS,
UNDERDRAINS AND IRRIGATION SYSTEMS**

TABLE OF CONTENTS

SECTION 100 - GENERAL 1

100.1 Description..... 1

100.2 Specification Modifications. 1

100.3 Revisions of Standards..... 1

100.4 Measurement and Payment. 1

100.5 Definitions..... 1

SECTION 101 - QUALITY CONTROL AND QUALITY ASSURANCE 2

101.1 Quality Control..... 2

101.2 Quality Assurance..... 2

TABLE 101 - REQUIRED QUALITY ASSURANCE TESTING 3

SECTION 102 - MATERIALS 4

102.1 Description..... 4

102.2 Contractor Requirements. 4

102.3 City Furnished Materials..... 4

102.4 Inspection and Testing..... 4

102.5 Handling..... 4

102.6 Storage..... 4

102.7 Pipe and Fittings for Water Mains and Service Connections. 5

102.7a Ductile Iron Fittings..... 5

102.7b PVC Water Distribution Pipe..... 5

102.7c Water Service Pipe and Fittings..... 6

102.8 Appurtenances for Water Distribution..... 6

102.8a Fire Hydrants..... 6

102.8b Gate Valves..... 7

102.8c Mechanical Restraint..... 7

102.8d Tapping Valves and Sleeves..... 7

102.8e Butterfly Valves..... 8

102.8f Valve Boxes..... 8

102.8g Air Valves..... 8

102.8h Vaults..... 8

102.8i Electrical Tracing Wire..... 8

102.8j Corporation Stops..... 8

102.8k Tapping Saddles..... 8

City of Grand Junction, Colorado
Table of Contents; Construction of Underground Utilities

SECTION	PAGE
102.8l Meter Setters.....	9
102.8m Reduced Pressure Backflow Prevention Devices.....	9
102.9 Pipe and Fittings for Sanitary Sewer Construction.....	9
102.9a PVC Gravity Sewer Pipe.....	9
102.9b PVC Pressure Sewer Pipe.....	10
102.10 Pipe and Fittings for Storm Drains, Culverts, Irrigation Systems, Siphons, and Under-drains.....	11
TABLE 102.10.....	11
102.10a Reinforced Concrete Pipe.....	12
102.10b PVC Solid Wall and Profile Wall Sewer Pipe for Storm Drains, Low Head Irrigation Systems and Under-drains.....	12
102.10c PVC Pipe for Irrigation Systems and Siphons.....	12
102.10d Polyethylene Pipe - Corrugated or Profile Wall.....	12
102.10e Polymer-Coated Galvanized Steel Pipe and Pipe-Arch.....	13
102.10f End Sections and Headwalls for Culverts.....	13
102.11 Manholes for Sanitary Sewers and Storm Drains.....	14
102.12 Irrigation Manholes.....	16
102.13 Storm Drain Inlet Boxes, Grates and Frames.....	16
102.14 Concrete and Mortar.....	16
SECTION 103 - REMOVALS, EXCAVATION, BACKFILLING AND RESTORATION.....	18
103.1 Description.....	18
103.2 Survey Line and Grade.....	18
103.3 Removal of Structures and Obstructions.....	18
103.4 Bracing and Sheet piling of Trenches.....	19
103.5 Trenches with Sloping Sides.....	19
103.6 Open Excavation Limits.....	19
103.7 Unauthorized Excavation and Pavement Removal.....	19
103.8 Unstable Trench Bottom.....	19
103.9 Bedding and Shaping Trench Bottom.....	20
103.10 Cutoff Walls.....	20
103.11 Rock Excavation.....	20
103.12 Stockpiling Excavated Material.....	21
103.13 Dewatering Trenches.....	22
103.14 Backfilling Pipe and Structures.....	22
103.15 Granular Stabilization, Bedding and Haunch Backfill Materials.....	24
103.16 Earth Backfill Material.....	24
103.17 Restoration of Grounds.....	26
103.18 Restoration of Paved Surfaces.....	26
103.19 Erosion Control.....	27
SECTION 104 - INSTALLATION OF PIPE AND APPURTENANCES.....	28
104.1 Description.....	28
104.2 Installation of Gravity Flow Pipelines.....	28

City of Grand Junction, Colorado
Table of Contents; Construction of Underground Utilities

SECTION	PAGE
104.2.a Laying Gravity Flow Pipe	28
104.2.b Installation of Sewer Service Lines.....	29
104.2.c Construction of Manholes.....	30
104.2.d Construction of Storm Inlets, Vaults and Irrigation Structures.....	31
104.3 Installation of Pressure Pipelines.....	32
104.3a Laying Pressure Pipe.....	32
104.3b Electrical Continuity.....	32
104.3c Polyethylene Encasement.....	33
104.3d Thrust Restraint.....	33
104.3e Installation of Gate Valves and Valve Boxes.....	33
104.3f Installation of Butterfly Valves.....	34
104.3g Installation of Fire Hydrants.....	34
104.3h Installation of Water Service Pipe.....	34
104.3i Connections to Existing Mains.....	35
104.4 Relationship Between Water Lines and Sanitary Sewers.....	35
104.5 Relationship Between Raw or Potable Water Flow Line and Public/Private Utilities	36
 SECTION 105 - PIPELINE TESTING.....	 37
105.1 Testing.....	37
105.2 Testing Sanitary Sewers.....	37
105.2a Leakage Tests.....	37
105.2b Alignment Testing.....	38
105.3 Testing Storm Drains, Culverts, and Gravity Irrigation Lines.....	39
105.4 Testing Pressure Pipelines.....	40
 SECTION 106 - DISINFECTION OF WATERLINES.....	 42
106.1 Disinfection Standard.....	42
 SECTION 107 - FINAL INSPECTION AND ACCEPTANCE	 45
107.1 Final Inspection and Acceptance.....	45
 SECTION 108 - MEASUREMENT AND PAYMENT	 46
108.1 Description.....	46
108.2 Conduit.....	46
108.3 Sewer Taps, Water Valves, Fittings and Hydrants.....	47
108.4 Water Service Lines.....	48
108.5 Manholes.....	49
108.6 Storm Drain Inlets.....	49
108.7 Granular Stabilization Material.....	50
108.8 Rock Excavation.....	51
108.9 Pavement Replacement.....	51
108.10 Erosion Control.....	51

City of Grand Junction, Colorado
Table of Contents; Construction of Underground Utilities

SECTION	PAGE
108.11 Traffic Control	51
108.12 Dust Control	51
108.13 Incidental Construction	52

**CITY OF GRAND JUNCTION, COLORADO
DEPARTMENT OF PUBLIC WORKS AND PLANNING
ENGINEERING DIVISION**

**STANDARD SPECIFICATIONS FOR THE
CONSTRUCTION OF UNDERGROUND UTILITIES -
WATER LINES, SANITARY SEWERS, STORM DRAINS,
UNDERDRAINS AND IRRIGATION SYSTEMS**

SECTION 100 - GENERAL

100.1 Description.

These specifications include material specifications and construction requirements for underground water, sewer, drainage and irrigation systems installed in City right-of-way and in other areas under City jurisdiction or ownership.

100.2 Specification Modifications.

Portions of these specifications may be modified or deleted by appropriate items in the Project Special Provisions. All other modifications and deletions shall be approved by the City Utility Engineer.

100.3 Revisions of Standards.

When reference is made to ASTM, AWWA, AASHTO, or other specifications or methods, it shall be understood to mean the latest edition or revision of said specification, as amended and issued at the time of the Advertisement for Bids.

100.4 Measurement and Payment.

Section 108, Measurement and Payment, applies only to City projects and is not required to be used on projects which are administered and paid for by private developers or other agencies.

100.5 Definitions.

The following abbreviations are used in these specifications:

AASHTO	American Association of State Highway and Transportation Officials
ANSI	American National Standards Institute
ASTM	American Society for Testing Materials
AWWA	American Water Works Association
OSHA	Occupational Safety and Health Administration

SECTION 101 - QUALITY CONTROL AND QUALITY ASSURANCE

101.1 Quality Control.

The Contractor is responsible for quality control of all work performance and shall implement whatever procedures, methods, testing, surveying, and supervision that is required in order to insure that the Work conforms to the Construction Plans and Contract Documents.

101.2 Quality Assurance.

The City, Developer, or other entity responsible for administering the construction of public facilities shall provide a quality assurance program. This program shall include systematic inspection and testing of the work and materials during construction to assure the Owner and the City that the Contractor is providing work that is in conformance with the City approved plans and specifications. Minimum quality assurance testing requirements for underground utility construction are given in Table 101.

Materials Testing Requirements. All sampling and testing shall be performed using the proper equipment as required by each test procedure. Technicians performing testing of soils or aggregates shall be NICET Level II, or WAQTC certified.

City of Grand Junction, Colorado
Standard Specifications for the Construction of Underground Utilities

TABLE 101 - REQUIRED QUALITY ASSURANCE TESTING

TEST REQUIRED	TEST PROCEDURE	COMPACTION REQUIREMENT	MINIMUM TEST FREQUENCY	
			Part Time Inspections	Full Time Inspection
Compaction of bedding, haunch and initial backfill material (testing of crushed rock is not required)	AASHTO T 99 and T 310	90% minimum	1 per 400 L.F. of mainline trench (and each branch, lateral or section of trench less than 400 feet in length) for each two-foot vertical depth of backfill material.	1 per 1000 L.F. of mainline trench (and 1 per 400 feet or less for each branch or lateral) for each two-foot vertical depth of backfill material.
Trench Backfill Compaction (native or imported soil) 1. Within right of way. 2. In all unimproved areas, easements and landscaped areas.	AASHTO T 99* ¹ and T 310	95% minimum* ¹ 95% minimum* ¹		
Compaction of aggregate base course material (road base)	AASHTO T 180 and T 310	95% minimum	1 per 200 S.Y.	1 per 400 S.Y.
Compaction of structure backfill within 24" of all structures (manholes, catch basins, vaults, etc.)	AASHTO T 180 and T 310	95% minimum	1 per each two-foot vertical depth of backfill material per structure or per 100 L.F. of structure perimeter.	

*1 Trench backfill shall be compacted to no less than 90% of the maximum dry density determined in accordance with AASHTO T 180 when specified, directed or approved in writing by the Engineer.

UU - 3

SECTION 102 - MATERIALS

102.1 Description.

This section covers pipe and other materials to be used in the construction of the various types of underground utilities. All materials used shall be new and in conformance with the applicable standards.

102.2 Contractor Requirements.

All materials to be furnished by the Contractor shall conform to the requirements of these specifications. The type, size and strength class of pipe, fittings and other materials shall be as shown on the *Construction Drawings* or otherwise specified in the *Contract Documents*.

102.3 City Furnished Materials.

When the City furnishes materials that are to be incorporated into the Work by the Contractor, provisions will be made in the Special Conditions as to the responsibilities of the City and the Contractor regarding delivery, unloading and storage of the materials.

102.4 Inspection and Testing.

All pipe shall be tested in conformance with the applicable standards. Testing may be witnessed by the Engineer's representative, or by an approved independent testing laboratory. Upon request of the Engineer, the Contractor shall provide a copy of certified test reports indicating that material does conform to the applicable standards or specifications.

102.5 Handling.

All materials shall be handled with equipment and methods adequate to prevent shock or damage. Under no circumstances shall materials be dropped. Pipe handled on skidways shall not be skidded or rolled against pipe already on the ground. If any part of the coating or lining is damaged, the Contractor shall repair or replace the material at his expense as directed by the Engineer. All pipe and appurtenances shall be handled in accordance with the appropriate AWWA and ASTM standards.

102.6 Storage.

The Contractor will be held responsible for the safe storage and protection of all pipe and other materials delivered to the work site. The interiors of all pipe and fittings shall be kept free from dirt and foreign matter at all times. Gaskets for pipe joints shall be stored in a cool location out of direct sunlight. If sunburned pipe is utilized, the City requires that the contractor provide a manufacturer's certification that all warranties are still valid. The City reserves the right to reject sunburned pipe depending on the severity of the apparent damage.

Any material that has been damaged before actual incorporation in the Work shall be repaired or replaced at the Contractor's expense.

102.7 Pipe and Fittings for Water Mains and Service Connections.

Pipe for all water mains shall be Polyvinyl Chloride (PVC) unless otherwise approved.

102.7a Ductile Iron Fittings.

Joints. Unless otherwise specified in the *Construction Drawings* or Special Provisions, ductile iron pipe joints shall be mechanical or push-on joints conforming to AWWA C111. Gaskets shall be of neoprene or other synthetic rubber material.

Fittings. Fittings for use with PVC pipe shall be ductile iron or cast iron conforming to AWWA C110 or C153. Fittings larger than 12-inch shall be cement-mortar lined per AWWA C104. Although minimal cracking in the cement lining is allowed, the absence of cement mortar lining in any part of the fitting shall be reason for rejection. All fittings, 12-inch and smaller, shall be coated inside and outside with fusion bonded epoxy coatings conforming to the requirements of ANSI/AWWA C116/A21.16.

~~One-Bolt Fittings shall conform to the material and performance requirements of ANSI/AWWA C153/A21.53.~~ Fittings shall be designed for use on ductile iron pipe conforming to ANSI/AWWA C151/A21.51 and PVC pipe conforming to AWWA C900. All fittings shall be provided with integral restrained joints and have seals conforming to ASTM F 477 and the physical testing requirement of AWWA C111. All fittings shall be coated with fusion bonded epoxy coatings conforming to the requirements of ANSI/AWWA C116/A21.16. Assembly of fitting joints shall not require beveling of the plain end of a cut pipe and shall not require the use of jacks or power equipment to force the pipe end past the gasket. Fittings shall be manufactured by One Bolt, Inc., or approved equal.

Bolts. All bolts for mechanical joints shall be Cor-Blue® bolts or approved equal. All bolts for flange connections shall be stainless steel bolts with the threads coated with anti-seize.

Polyethylene Encasement. Unless otherwise specified or approved by the City Utilities Engineer, all ductile iron fittings larger than 12" shall be wrapped with polyethylene encasement material conforming to AWWA C105, or shall be provided with fusion bonded epoxy coating conforming to the requirements of ANSI/AWWA C116/A21.16.

102.7b PVC Water Distribution Pipe.

PVC pipe and fittings for the City's water distribution system shall conform to AWWA C900 for sizes 4" through 12" and to AWWA C905 for sizes 14" through 36". Unless otherwise specified, the minimum thickness class of C900 PVC pipe shall a Dimension Ratio (DR) of 18. Minimum thickness class of C905 PVC is DR25.

Joints. Joints shall be bell and spigot type sealed with elastomeric gaskets conforming to ASTM D3139. Couplings shall be able to withstand the same internal pressure and external loading as the pipe.

Fittings. PVC fittings will not be allowed. Ductile iron and cast iron fittings for use on PVC pipe shall conform to subsection 102.7a.

102.7c Water Service Pipe and Fittings.

Copper Tubing. Copper tubing for water service lines 3/4" through 2" in diameter shall be Type K, soft temper copper tubing for underground service conforming to ASTM B-88 and ASTM B-251. The pipe shall be marked with the manufacturer's name or trademark and the type of pipe. The outside diameter of the pipe and minimum weight per foot shall not be less than that listed in ASTM B-251, Table II.

PVC Water Service Pipe. PVC pipe for water service lines will be allowed for pipe greater than or equal to 3" in diameter. Three inch diameter shall conform to ASTM D-2241 and unless otherwise specified, all pipe shall be CL 200 psi. All services 4" and larger shall conform to AWWA C 900.

HDPE Water Service Line. HDPE pipe for water service lines will be allowed for pipe sizes 1½" and 2". This pipe material is suitable for water service line, or irrigation system infrastructure. Pipe materials must meet HDPE 3408 – ASTM D2239 and ASTM D2737 and be produced from virgin material (Natural Virgin Core with Blue virgin Exterior) or Utility Engineer approved equal.

Fittings. All fittings for copper water service lines shall be brass and have flared or Mueller 110 type compression copper connections. 2" gate valves for water service lines shall not be allowed. Curb stops shall be used for all water service line 2" in diameter or smaller. If copper service line is not utilized, 12" long brass nipples shall be installed on each side of the curb stop valve to mitigate potential twisting of the valve during operation.

—Valve shall have IP thread outlet, male to compression adapter to 2 inch Type K copper service.

Sealants. Acceptable sealants are Harvey's Tee Paste as manufactured by William H. Harvey Company of Omaha Nebraska 68117 (402-331-1175) or Spear's Blue-75 Thread Sealant as manufactured by Spear's Manufacturing Company of Sylmar CA 91392 (818-364-1611). Rectorseal-5 is NOT acceptable.

102.8 Appurtenances for Water Distribution.

102.8a Fire Hydrants.

Fire hydrants shall be the dry bowl type and shall conform to AWWA C-502. The standard hydrant shall have a six-inch connection, a 5¼-inch main valve opening, two (2) 2½-inch hose nozzles and one (1) 4½-inch pumper nozzle. The hydrant barrel shall be marked with a circumferential rib to denote the intended ground line. The centers of the hose nozzle and pumper nozzles shall be at least 18 inches above the ground line mark.

Hydrants shall be of the "traffic" or "breakaway" design, having easily replaceable breaking devices for the grade line flange and operating stem that prevents damage to the barrel sections upon impact. The operating nut and nozzle cap wrench nuts shall be 1-inch pentagon, measured from point to opposite flat side at the base. The height of the nut shall not be less than one inch. The nozzle caps shall be removed and the operating nut opened by turning to the left (counter-clockwise). Nozzle caps shall be securely chained to the upper barrel section. The 2½-inch hose nozzles shall be National Standard fire hose

City of Grand Junction, Colorado
Standard Specifications for the Construction of Underground Utilities

thread. The pumper nozzle shall be a Mueller A-423, Clow Medallion 2545 or approved equal with the following requirements:

1. Outside diameter of male thread is 5.282 inches.
2. Diameter of root male thread is 4.932 inches.
3. Number of threads per inch is 4.
4. Pitch diameter is 5.12 inches.

Painting/Coating. Fire hydrants shall be painted with Rust-O-Leum Fire Hydrant Enamel "Safety Yellow", alkyd enamel paint or an approved substitute.

102.8b Gate Valves.

Gate valves shall be resilient seat or resilient wedge type gate valves conforming to AWWA C-509. Valves shall have cast iron or ductile iron bodies and bronze mounted non-rising stems with o-ring seals. The stem and all wearing surfaces shall be bronze or other approved non-corrosive material. Valves shall turn left to open. The interior of all gate valves shall be coated with fusion bonded epoxy coating conforming to the requirements of ANSI/AWWA C550.

End Connections. End connections of gate valves shall consist of mechanical or push-on (rubber-gasket) joints conforming to AWWA C-111 or flanged ends in accordance with ANSI B-16.1.

Wrench Nuts. Wrench nuts shall be made of cast iron and shall be 1 5/16-inches square at the top, 2 inches square at the base and 1 3/4-inches high.

Bolts. All packing bolts and valve bonnet bolts shall be stainless steel. All bolts for mechanical joints shall be Cor-Blue® bolts or approved equal. All bolts for flange connections shall be stainless steel bolts coated with anti-seize.

102.8c Mechanical Restraint.

Valves and fittings shall be restrained by mechanically connecting them to the pipe or other fittings. Fitting to fitting connections may be made with a flange by flange connection or an integral ring anchoring fitting by mechanical joint connection. Pipe by fitting connections shall be restrained with a Megalug®, JCM®, Uniflange Series 1500®, Stargrip Series 4000® or other approved joint restraint. When using mechanical restraints, restraints shall also be used on the slip joints adjacent to mechanical restraint. Where a short piece of pipe is installed between a fitting and a valve or other fitting, the restraint may be provided by connecting the mechanical joints with 5/8" zinc-coated, all-thread, steel rod. The rod shall be connected to the mechanical joint fitting using tie-back bolts, not through the fitting's bolt holes. The rod shall be coated with an asphalt sealant. All mechanical restraints shall be encased with polyethylene in accordance with Section 104.3c.

102.8d Tapping Valves and Sleeves.

Connections for line extensions of 4" and larger lines may be made with tapping sleeves and valves. Tapping valves shall be furnished with flanged inlet end connections having a machined projection on the flanges to mate with a machined recess on the outlet flanges of the tapping sleeves ~~and crosses~~. The outlet ends shall conform in dimensions to the AWWA C-115 for the flange and AWWA C-111 for the hub or mechanical joint connection, except that the outside of the hub shall have a large flange for attaching a drilling machine.

City of Grand Junction, Colorado
Standard Specifications for the Construction of Underground Utilities

The seat opening of the valves shall be larger than normal size to permit full diameter cuts. The tapping sleeve shall be of the same manufacture as the tapping valve. Either the tapping valve or the tapping sleeve shall have a test plug. All packing bolts shall be stainless steel. All bolts for mechanical joints shall be Cor-Blue® bolts or approved equal. All bolts for flange connections shall be stainless steel bolts coated with anti-seize.

102.8e Butterfly Valves.

Butterfly valves shall conform to AWWA C-504. The Contractor shall submit for approval by the Engineer, drawings and literature showing the type, class, principal dimensions and materials used for all parts of the valves and operator. All packing bolts shall be stainless steel. The interior of all butterfly valves shall be coated with fusion bonded epoxy coating conforming to the requirements of ANSI/AWWA C550.

102.8f Valve Boxes.

A cast iron valve box and lid shall be provided for each underground valve. Valve boxes shall be 5 ¼ inch diameter, slip type, sized for the type of valve and depth of bury. The lid shall have the word "WATER" permanently cast on the top.

102.8g Air Valves.

Air valves shall be of the type, class and size specified in the Special Provisions or on the *Construction Drawings*. A separate isolation valve of the same size and pressure rating as the air valve shall be installed between the water main and the air valve. The isolation valve shall be a ball valve with a 2 inch square nut on top for operation. This valve shall be placed inside a standard valve box separate from the air valve.

102.8h Vaults.

The vaults for air valves and butterfly valves shall be made of reinforced concrete pipe or a manhole riser section. The cover shall be a pre-cast concrete lid with a cast iron manhole ring and cover. The diameter of the vault will be as detailed on the plans. The cover for the air valve vault shall be perforated if a riser pipe is not to be installed as shown on the *Standard Drawings*. The total area of perforations in the manhole cover shall be as detailed on the plans or specified by the Engineer.

102.8i Electrical Tracing Wire.

Electrical tracing wire shall be size No. 10, Type UF solid copper, direct-bury wire. Splices shall be dry compression type wrapped sufficiently with TBT-20 rubber tape to provide a water tight seal. designed for direct bury applications.

102.8j Corporation Stops.

Corporation stops shall be made of brass and shall be the same size as the service line. The outlet end of the stop shall be threaded in accordance with AWWA C-800, for use with Type K flared or Mueller compression copper service tubing. If the service line is tapped directly into the water main the inlet threads of the stop shall be tapered in accordance with AWWA C-800. If a tapping saddle is used, the inlet threads of the corporation stop shall be CC for ¾" and 1", not standard iron pipe threads.

102.8k Tapping Saddles.

For ¾" to 2" service connections, wide-body brass tapping saddles (Mueller BR2B Series or approved equal) shall be used on 8" and smaller water mains and may be used on

larger mains. Tapping saddles on 10" and larger water mains may be all stainless steel or epoxy- or nylon-coated ductile iron bodies with stainless steel straps – either double straps or a wide single strap (Smith-Blair 317, PowerSeal 3417DI, Mueller DR2S, or approved equal). All tapping saddles shall have a flat neoprene seal. The inside diameter of the saddle shall be approximately the same as the outside diameter of the pipe being tapped, so uniform pressure is applied to the full circumference of the pipe when the saddle is secured. Tapping saddles for steel pipe shall be an approved "weld on" type.

102.8l Meter Setters.

Meter setters shall be brass and shall be the same size as the service line. The inlet and outlet ends shall be threaded in accordance with AWWA C-800 for use with Mueller compression fittings to the Type K copper service tubing. All setters shall be equipped with a ball type; yoke stop valves with an approved locking device.

102.8m Reduced Pressure Backflow Prevention Devices.

Reduced pressure backflow prevention devices shall be the same as the service line and shall be approved by the Foundation of Cross-Connection Control and Hydraulic Research at the University of Southern California.

102.9 Pipe and Fittings for Sanitary Sewer Construction.

Pipe used in construction of gravity sanitary sewer mains and service lines shall be polyvinyl chloride (PVC) conforming to 102.9a. Sanitary sewers that operate under pressure shall be PVC conforming to 102.9b.

The minimum pipe size for gravity sewers shall be eight-inch (8") diameter for mains and laterals, and four-inch (4") diameter for service lines unless otherwise specified or approved.

Service taps for new construction shall be accomplished utilizing full body wye fitting. For taps into existing clay or concrete sewer lines, "Inserta tees" manufactured by Inserta Fittings Company of Hillsboro, Oregon (503-357-2110) or approved equal will be used in accordance with manufacturer's specifications. For existing PVC mains, tapping saddles will be used.

102.9a PVC Gravity Sewer Pipe.

PVC sewer pipe and fittings shall conform to ASTM D-3034 Type PSM for diameters 4" to 15" and ASTM F-679 Type I for diameters 18" to 27". The minimum wall thickness for PVC pipe shall conform to Standard Dimension Ratio (SDR) 35. Joints shall be bell-and-spigot type with flexible elastomeric seals conforming to ASTM D-3212 and shall not be longer than 143 feet in length. Gaskets shall be neoprene or other synthetic rubber material conforming to ASTM F-477. The bells shall be integrally formed with the pipe or fitting.

Profile wall PVC pipe may be used for sizes 15" through 36" unless otherwise shown on the plans or specified. Profile wall pipe shall be seamless and meet the requirements of ASTM F949 or ASTM F794. The pipe stiffness shall be a minimum of 46 psi when tested at 5% deflection in accordance with ASTM D-2412.

102.9b PVC Pressure Sewer Pipe.

PVC pipe used for sanitary sewers under pressure shall meet the requirements of ASTM D-2241 (IPS) or AWWA C-900. Joints shall conform to ASTM D-3139 and have elastomeric seals conforming to ASTM F-477. The type and pressure class shall be as shown on the *Construction Drawings* or otherwise specified.

Small sewer force mains (1½" to 2") may be installed using pipe materials meeting HDPE 3408 – ASTM D2239 and ASTM D2737. The pipe must be produced from virgin material (Natural Virgin Core with Blue Virgin Exterior) or Utility Engineer approved equal.

Fittings. Fittings used in force mains or any other application pressurized by pumps, shall conform to the requirements of Subsection 102.7a.

102.10 Pipe and Fittings for Storm Drains, Culverts, Irrigation Systems, Siphons, and Under-drains.

Pipe shall be of the type shown in the following table unless otherwise specified or approved by the Engineer. All pipes shall have a minimum design life of fifty (50) years. The wall thickness and/or class of pipe shall be determined by the Engineer based on the dead and live loads applied over the design life included maximum live loads that will be applied to the pipe during construction. Pipes installed under roadways, driveways and parking areas shall be designed for H-20 minimum live load.

TABLE 102.10

	Storm Drains	Culverts	Pressurized Irrigation and Siphons	Low head Irrigation	Under-drains or French Drains
Reinforced Concrete pipe (RCP) 12" – 144"	X	X		X	
PVC Sewer Pipe 4" - 36"	X			X	X
PVC Profile Wall Sewer Pipe 15" – 36"	X	X		X	
PVC Irrigation Pipe (PIP) 6" – 27"			X	X	X
PVC Pressure Rated Pipe (IPS) ASTM D22411 ½" - 12"			X	X	
AWWA C900 or C905 PVC Pressure Pipe 4" – 36"	X	X	X	X	
Corrugated Polyethylene Pipe 3" – 47"	X	X		X	X
Profile Wall Polyethylene Pipe 18" – 120"	X	X			
Corrugated Polymer-Coated Galvanized Steel Pipe and Pipe-Arch 18" – 126"	X	X			

102.10a Reinforced Concrete Pipe.

Reinforced Concrete Pipe (RCP) shall be manufactured in accordance one of the following standards:

ASTM C 76 or ASTM C 655 - RCP (designed for specific D-loads).

ASTM C 507 - Reinforced Concrete Elliptical Pipe

ASTM C 506 - Reinforced Concrete Arch Pipe

ASTM C 361 - Low Head Concrete Pressure Pipe - All Concrete Pipe shall meet the requirements of this standard

Reinforced concrete pipe shall be made with Type V cement or other approved cement having less than 5% tricalcium aluminate. RCP shall not be used where the pH of the soil is less than 5.

Joints. RCP joints shall be manufactured with flexible water tight joints conforming to ASTM C443 unless otherwise specified or approved by the City Utilities Engineer. Non-water tight joints, when approved, shall conform to ASTM C 990.

102.10b PVC Solid Wall and Profile Wall Sewer Pipe for Storm Drains, Low Head Irrigation Systems and Under-drains.

Solid wall and profile wall PVC pipe and fittings shall meet the requirements of Section 102.9.

102.10c PVC Pipe for Irrigation Systems and Siphons.

The following pipes are approved for construction of irrigation systems and siphons:

1. PIP-PVC Irrigation Pipe conforming to ASTM D2152, D2444, D1599 and F477. The minimum pressure rating to be used in public right-of-way shall be 160 psi (SDR 26)
2. Pressure Rated PVC (IPS) pipe conforming to ASTM D2241 and F477. The minimum pressure rating to be used in public right-of-way shall be 160 psi.
3. AWWA C900 PVC pipe (4" through 12" diameter).
4. AWWA C905 PVC pipe (14" through 36" diameter)

The pipe size and pressure rating shall be as shown on the plans or otherwise specified.

Joints. Pipe joints may be either bell and spigot type sealed with elastomeric gaskets or solvent welded type conforming to ASTM D2564. Elastomeric seals shall conform to ASTM F477.

102.10d Polyethylene Pipe - Corrugated or Profile Wall.

Polyethylene pipe for storm drains and low head irrigation systems shall be either corrugated pipe with a smooth inner liner conforming to AASHTO M252, Type S or AASHTO M294, Type S, or profile wall pipe conforming to ASTM F894.

Polyethylene pipe for under-drains shall have a smooth interior conforming to AASHTO M252 or AASHTO M294, Type S or SP.

City of Grand Junction, Colorado
Standard Specifications for the Construction of Underground Utilities

Polyethylene pipe for culverts shall conform to AASHTO M 294, Type C or S, or profile wall pipe conforming to ASTM F894.

Joints. Corrugated polyethylene pipe used for storm drains and low head irrigation systems shall have bell and spigot gasketed joints meeting AASHTO M294 or MP6-95. The joint shall be designed so that when assembled, the elastomeric gasket located on the spigot end is compressed radially on the pipe to form a water tight seal. The joint shall be designed to prevent displacement of the gasket from the joint during assembly and when in service. The pipe shall have a "home" mark on the spigot end to indicate proper penetration when the joint is made. The elastomeric gasket shall meet the provision of ASTM F477.

Couplings for culverts and under drains may be bell and spigot, coupling bands or other type conforming to AASHTO M294. All culverts shall have gasketed joints for a water tight seal.

Couplings for profile wall polyethylene pipe shall be bell and spigot gasketed type or thermal welded in accordance with the manufactures recommendations.

Fittings. Fittings shall conform to AASHTO M294 or MP6-95. Fabricated fittings shall be welded on the interior and exterior at all junctions.

102.10e Polymer-Coated Galvanized Steel Pipe and Pipe-Arch.

Polymer-coated galvanized steel pipe, pipe-arch and coupling bands shall meet the requirements of AASHTO M218, M246 and M245. The pipe shall consist of a corrugated steel exterior shell with a hydraulically smooth steel liner. The liner shall be continuously attached to the exterior shell along a locking seam. Both sides of the exterior shell and steel liner shall be polymer-coated.

Joints. Coupling bands shall be sealed to the pipe with rubber gaskets to produce a watertight joint.

102.10f End Sections and Headwalls for Culverts.

End section shall be pre-cast reinforced concrete conforming to CDOT Standard Plan No. M-603-10, and Section 706 of the CDOT Standard Specifications for Road and Bridge Construction. Headwalls shall be reinforced concrete conforming to CDOT Standard Plan No. M-601-10 unless otherwise shown on the plans or approved by the Engineer.

102.11 Manholes for Sanitary Sewers and Storm Drains.

Manholes shall be constructed in accordance with *City Standard Drawings*.

Cement . All cement used in mortar, and concrete used in concrete bases, and precast manhole riser sections, cones and flat tops, for sanitary sewer manholes, shall be Type V or modified Type II Portland cement having less than five (5) percent tricalcium aluminate.

Precast Concrete Manhole Sections. Manhole risers, cones, flat tops and grade rings shall be precast reinforced concrete sections conforming to ASTM C-478 or AASHTO M-199. Flat top lid slabs will not be allowed for manholes located in an asphalt road section. Manhole risers, cones and flat tops shall be made with tongue and groove ends for continuous and uniform joints between sections. Joint configuration shall be consistent throughout each manhole, use of non compatible manhole joints on new systems or modification to existing systems shall not be allowed. The joint sealant shall be a flexible, preformed, bitumastic joint sealant.

Invert Epoxy Gel. All sanitary sewer manholes that are not constructed as a through manhole, pipe laid continuously through the manhole providing a PVC invert, shall have a minimum fall across the manhole of 0.16 feet. The concrete invert of the manhole shall have a steel trowel finish free of transverse or longitudinal trowel marks. Broom finishes are not acceptable.

In the event that 0.16 feet of positive fall cannot be maintained across the manhole, the manhole invert shall be coated with an epoxy material suitable for feathering and vertical application. Epoxy coating shall be Sherwin Williams COR-COTE SC (sewer cote), TNEMEC Perma-Glaze Series 435, or Utility Engineer approved equal.

The epoxy shall be applied to a clean dry concrete surface free of dust, dirt, grease, laitance, curing compounds and other foreign matter by sandblasting, mechanical abrasion or hydro blasting. Air surface temperature during application and curing shall be 50 Degrees F or above. Mixing shall be accomplished using a low speed drill with a jiffy mixer or paddle. Epoxy shall be mixed in a clean dry container free of foreign matter or debris. Mixing rates shall be as recommended by the manufacturer.

In manholes with limited fall from pipe invert in to pipe invert out the concrete invert may need to be ground to allow continuous positive fall through the manhole. Mix epoxy in accordance with the manufacturer's instructions. Epoxy may be brush applied in thin coats to provide a slick surface through the concrete invert of the manhole. Epoxy seems to perform best if applied prior to approximately the first ten to twelve minutes of pot life. The cured surface of the epoxy coating shall be free of brush marks and shall have a cross section consistent with that of the PVC pipe.

Manhole Waterproofing. When manhole waterproofing is required by the Project Specifications or on the Plans, the exterior surface of base, riser sections and cone shall be coated with minimum 10 mil. coal tar epoxy. Waterproofing may be field applied.

Corrosion Protection. All drop manholes (manholes with fall greater than 0.40' fall through the manhole), force main outlet manholes, and lift station wet wells shall be coated on the interior surfaces of the riser, cone and other exposed concrete surfaces with a minimum 30 mil dry thickness of Sherwin Williams COR-COTE SC Sewer Cote, haze grey color, (Part A B62-450, Part B B62V450); Tnemec Perma-Glaze Series 435, or an approved equal. The epoxy coating shall be shop applied to concrete after concrete has cured 28 days or steam cured over a 24 hour period or as required to meet the 28-day

City of Grand Junction, Colorado
Standard Specifications for the Construction of Underground Utilities

strength requirements. The epoxy shall be applied to a clean dry concrete surface free of dust, dirt, grease, laitance, curing compounds and other foreign matter by sandblasting, mechanical abrasion or hydro blasting. The surface of the concrete to be coated shall be free of bug holes or other imperfections that may allow for porosity in the coating. Air surface temperature during application and curing shall be 50 Degrees F or above. Mixing shall be accomplished using a low speed drill with a jiffy mixer or paddle. Epoxy shall be mixed in a clean dry container free of foreign matter or debris. Mixing rates shall be as recommended by the manufacturer.

Apply coating in accordance with manufacturer's recommendations and allow to dry and harden prior to transporting precast sections to the project.

For application on existing manholes, Tnemec Perma-Glaze Series 435, or Sherwin Williams COR-COTE SC (Sewer Cote) or approved equal, may be used. City inspection of the manhole is required prior to application of the product to ensure proper surface preparation has been accomplished. The manufacturer's recommendations for application in confined space areas shall be followed

After the structure is installed and backfilled, all surfaces covered with an epoxy coating shall be tested with an electric Holiday detector. The voltage and specific methods of testing shall be as recommended by the manufacturer of the coating material.

Sheet linings such as the Amer-Plate "T-Lock" shall not be used for protection of concrete manholes, lift station wet well, or other concrete structures.

Manhole Steps. Steps are required in all manholes unless otherwise shown on the plans or specified in the Contract Documents. Manhole steps shall be a manufactured from copolymer polypropylene plastic with ½" diameter, Grade 60 steel core. The steps shall be set in the wall of the manhole riser at the time the riser is manufactured. For pre-cast manhole bases with integral riser sections, the steps and access hole shall be installed in alignment at a 45 degree angle from the inlet pipe (measured from the center of the manhole). The spacing between steps shall be such that when the manhole components are assembled the spacing is in conformance with OSHA Standards.

Pipe-to-Manhole Connector. Pipe-to-manhole connectors shall be manufactured with rubber conforming to ASTM C-923. All metal components shall be stainless steel.

Rings and Covers. Manhole rings and covers shall be grey iron conforming to AASHTO M 105, Class 30 and shall be designed to withstand HS 20 loading. The standard City of Grand Junction manhole is Castings Inc. MH-250-24D CI or an approved, fully interchangeable substitute. For sewer manholes located in a sidewalk or other pedestrian way the ring and cover shall be a Castings Inc. MH-250-24D CI (checker pattern lid) or an approved substitute. The bearing surfaces between the ring and cover shall be machine finished or ground to assure non-rocking fit in any position and interchangeability. The cover shall have a beveled pick hole that has a width of ¾" at the top and 1" at the bottom. The length of the pick hole (along the circumference of the lid) shall be at least 1½". The word "SEWER" shall be cast in the cover of sanitary sewer manholes.

Storm sewer manholes covers shall be Castings Inc.24-B-CI (FISH) or an approved substitute.

Inverted rings and covers are not allowed unless approved by the City Utility Engineer.

Watertight Manhole Covers. Where a watertight manhole is required, the ring and cover shall be equipped with a gasket or o-ring. The cover shall have no holes that could allow the intrusion of water into the manhole. The ring and cover shall be drilled and tapped at 90° spacing and 4 stainless steel bolts shall be furnished to secure the cover to the ring. Anti-seize compound **shall** be applied to **the bolt** threads prior to installation.

The standard ring and cover for watertight manholes shall be Castings MH-250-24 **Bolt Down** CI or approved equal.

Manhole Extension Ring. Under no circumstances will manhole extension rings be permitted for new construction. For asphalt overlays, a cast iron manhole extension ring may be used to adjust the elevation of a manhole ring and cover only when the cross slope of the pavement surface does not change. Only one cast iron extension ring will be allowed on each manhole. The manhole extension ring shall be one piece and shall be the same height as the overlay thickness. The extension ring shall be attached to the manhole ring with three stainless steel set screws evenly spaced.

Infiltration: There shall be no visible infiltration into the manhole after construction of any sanitary sewer manhole. If there is visible infiltration, the manhole shall be repaired to stop visible infiltration at the Contractors expense.

Acceptable materials for repair shall include, but are not limited to, the use of Xypex Patch and Plug, Quick Crete Hydraulic Water Stop, or other materials or systems approved by the City Utilities Engineer.

102.12 Irrigation Manholes.

The standard irrigation manhole for off-street applications shall be constructed from 30-inch diameter reinforced concrete pipe conforming to ASTM C 76. A concrete bottom shall be cast in place or pre-cast with the pipe. Manholes placed in public roadways shall be constructed in accordance with ASTM C 478 or AASHTO M-199 with a Castings Inc. MH-250-24 C.I. (cast iron) ring and cover or an approved substitute. For irrigation manholes located in sidewalks or other off-road locations, the ring and cover shall be a Castings Inc. MH-250-24 AL (aluminum) or an approved substitute. The word "IRRIGATION" shall be cast into the cover of all irrigation manholes.

102.13 Storm Drain Inlet Boxes, Grates and Frames.

Precast storm drain inlet boxes shall be constructed in accordance with AASHTO M259M or M273M for boxes with less than two feet of cover subjected to highway loading. All inlet grates, frames and curb boxes shall be of cast iron of the type and manufacturer identified on the *City Standard Drawings*. All grates and frames in traffic areas shall be bicycle safe, shall be designed to withstand HS 20 loading and shall meet the requirements of AASHTO M 105, Class 30. Inlet boxes shall be constructed of pre-cast or cast-in-place reinforced concrete, to the dimensions shown on the City Standard Details or as otherwise shown on the project plans.

102.14 Concrete and Mortar.

Cast in place concrete used in construction of concrete encasement, thrust blocks, and other structures, shall meet the requirements of CDOT Class B (4500 psi compressive

City of Grand Junction, Colorado
Standard Specifications for the Construction of Underground Utilities

strength at 28 days) unless otherwise specified or approved. All concrete shall be made with Type V or Type II modified Portland cement having less than five (5) percent tricalcium aluminate.

Cement mortar used in construction or maintenance of manholes, inlets, vaults, etc., shall be a non-shrink grout conforming to ASTM C-109 and ASTM C-191

Grout used for setting/adjusting cast iron manhole rings shall be QUIKRETE® Rapid Road Repair (No. 1242) or an approved an equal.

All-Crete 5 Minute Set (Fostroc Inc, Georgetown KY) or an approved equal shall be used for manhole invert work.

SECTION 103 - REMOVALS, EXCAVATION, BACKFILLING AND RESTORATION

103.1 Description.

For the purpose of this section, underground conduits shall be considered sanitary sewers, storm drains, water mains, irrigation lines or any other underground pipeline. Wherever the term "pipe" or "pipeline" is used it shall mean underground conduit.

This section covers surface removals, excavation, backfilling, compaction, disposal of surplus material, restoration of disturbed surfaces, and all other work required for the safe and proper construction of underground conduits.

103.2 Survey Line and Grade.

All construction surveying and staking shall be performed by or under supervision of a professional engineer or land surveyor registered in the State of Colorado. The Contractor shall use a laser instrument to maintain and control the line and grade of all gravity flow pipelines including sanitary sewers, storm drains and irrigation lines. Check points shall be set at 25 feet, 50 feet, 100 feet and 200 feet from the beginning of each reach of pipe to assure that the laser is on the correct line and grade.

Staking intervals for construction surveying shall be such that the work can be efficiently and accurately completed. Staking shall be referenced to the horizontal and vertical control as shown on the plans or as provided by the City. Offset stakes, if used, shall be clearly marked with the offset distance and other pertinent information. The Surveyor's grade sheets shall be submitted to the Construction Inspector as the project is staked.

103.3 Removal of Structures and Obstructions.

The removal of structures and obstructions shall be in accordance with Section 202 of the *Standard Specifications for Road and Bridge Construction*. The Contractor shall remove surface materials and obstructions only to the widths necessary for excavation of the trench. All trees, shrubbery, fences, plantings and structures not designated for removal shall be protected or, if moved, restored to their original condition after construction is complete. Removal of concrete curbs, gutters, sidewalks, driveways, and asphalt pavement shall be along existing joints or neatly cut lines.

All vegetation, concrete, and other refuse removed from the construction limits shall be separated from suitable topsoil and backfill material, and hauled to a disposal site secured by the Contractor and approved by the City unless otherwise specified in the Contract Documents.

Unless otherwise shown on the plans or specified in the contract documents, all asphalt pavement designated for removal (method unspecified) shall become the property of the Contractor. Asphalt pavement designated for removal by planing (milling) shall remain property of the City and shall be transported to the City Shops located at 2549 River Road unless otherwise specified or approved. The Contractor shall be responsible for hauling and/or disposal of all pavements removed.

Where the trench is in an unpaved area, clean topsoil suitable for final grading shall be stripped, stockpiled separately in approved locations, and restored to the original thickness after the trench is backfilled.

103.4 Bracing and Sheeting of Trenches.

All trenches shall be properly braced, sheeted or otherwise supported to provide safe working conditions and protection of the work, workers and adjacent property. Bracing, trench shields and sheeting shall conform to the recommendations in the Occupational Safety and Health Standards for Construction (OSHA). Unless otherwise approved, all trench support materials shall be removed in a manner that will prevent caving of the sides and movement or other damage to the pipe.

103.5 Trenches with Sloping Sides.

Where working conditions and right-of-way width permit, trenches in unimproved areas may be excavated with sloping sides in accordance with OSHA requirements. All soils shall be assumed to be OSHA Type C Soil, unless otherwise classified by a qualified soils technician. Trenching and other excavations shall not extend beyond existing easements, right-of-way or limits shown on the *Construction Drawings* unless otherwise approved by the property owner and the Engineer.

In streets, alleys or narrow easements, trenches shall be excavated with vertical sides, properly braced and supported, unless otherwise approved by the Engineer.

Where trenches with sloping sides are permitted, the slopes shall not extend below a point 12 inches above the top pipe. The trench shall be excavated with the vertical sides below this point with widths not exceeding those specified on the *City Standard Drawings*.

103.6 Open Excavation Limits.

The length of open trench shall be kept to a minimum and shall not exceed the length necessary to accommodate pipe laying and backfilling operations unless otherwise approved by the Engineer. The Contractor shall be responsible for covering or barricading unattended trenches and excavations as necessary for protection of the public and the work. All trenches and excavations shall be backfilled at the end of each work day, unless otherwise shown on the plans or approved by the Engineer. The end of a trench may be left open overnight if the entire perimeter of the excavation is fenced, lighted and barricaded with construction equipment and/or Jersey barriers. No traffic lane shall be blocked by an open excavation, piece of equipment or other obstruction without a proper lane closure, road closure or other approved traffic control.

103.7 Unauthorized Excavation and Pavement Removal.

Unless authorized by the Engineer, all removed pavement and excavations made beyond the lines and grades shown on the *Construction Drawings* or described in the *Contract Documents* shall be replaced at the Contractor's expense.

103.8 Unstable Trench Bottom.

Where the excavation is found to consist of muck, organic matter or any other material that is determined, by the Engineer, to be unsuitable for supporting and maintaining the line and grade of the pipe, the trench shall be excavated to an additional depth as agreed upon by the Contractor and Construction Inspector/Engineer, and replaced with an approved

granular stabilization material. Should the Contractor and Inspector/Engineer fail to reach an agreement as to the depth and/or method of trench foundation stabilization, the City may secure the services of a Geotechnical Engineering to assist in determination of an appropriate method for stabilization.

103.9 Bedding and Shaping Trench Bottom.

Unless otherwise directed or specified in the Special Provisions, all trenches shall be excavated to at least six (6) inches below the pipe grade and backfilled to grade with approved granular bedding material. The bedding material shall be hand shaped and graded until the trench bottom is uniform and free from rocks, bumps, and depressions. A coupling or bell hole shall be dug at each pipe joint with sufficient length, width and depth to permit assembly of the joint and provide a minimum clearance of two (2) inches between the coupling and the trench bottom.

After the pipe is joined, pipe-bedding material shall be placed and tamped under each pipe joint until all voids are filled. Care shall be taken not to displace the pipe from its line and grade.

103.10 Cutoff Walls.

Cutoff walls shall be installed along every utility line to inhibit the movement of ground water through the screened rock bedding. Cutoff walls shall be 5 to 10 feet long and consist of native material or imported material that has a permeability rate the same or less than that of the native material. Cutoff walls shall be constructed by discontinuing the installation of bedding and haunch backfill material and installing approved native or imported material. Cutoff walls shall be installed at intervals not exceeding 200 feet on pressurized lines. On gravity flow lines, cutoff walls shall be installed on every line, 10 to 20 feet upstream of every manhole or box.

103.11 Rock Excavation.

Rock excavation shall consist of the removal of boulders or concrete measuring one-half (1/2) cubic yard or more, hard shale, sandstone or other bed rock which, in the opinion of the Engineer, requires for its removal the continuous use of pneumatic tools or drilling and blasting. Rock excavation shall be in accordance with Section 203 of the *CDOT Standard Specifications for Road and Bridge Construction*.

Before payment for Rock Excavation is approved, the Contractor will be required to demonstrate that the material cannot be removed by hand pick or by power operated excavator weighing no less than 45,000 pounds. No payment will be made for Rock Excavation unless authorized by the Engineer in writing prior to the work being done.

Blasting. Whenever rock excavation is encountered, air or hydraulic hammers or some equivalent method will be used if possible. Blasting shall be used only if other methods have proven unsuccessful and only upon the Engineer's approval.

In addition to the requirements of the *General Contract Conditions*, blasting will be allowed only after the following conditions have been satisfied:

1. One competent experienced person shall be specifically designated in charge of explosives and all related activities. The blaster-in-charge shall carefully supervise all work related to the use, storage, transportation, and handling of explosives. The blaster-in-charge or the Contractor shall select a blasting crew to assist with explosives

City of Grand Junction, Colorado
Standard Specifications for the Construction of Underground Utilities

activities, including transportation and area security. Only the minimum number of competent, experienced personnel, consistent with efficient operation, shall be permitted to handle explosives. Anyone demonstrating carelessness, incompetence, or inexperience shall be excluded from further handling of explosives. The blaster-in-charge shall demonstrate the following minimum qualifications:

- a. Proof of a valid Colorado Blaster's License or other license issued by an equivalent licensing body.
 - b. Written résumé showing not less than three years of active involvement as blaster-in-charge on projects similar in scope to the current project.
 - c. Five references who can testify to the known qualifications and reliability of the proposed blaster-in-charge.
2. The blasting crewmembers shall demonstrate the following minimum qualifications:
- a. Completion of at least 24 hours of explosives and blasting safety training.
 - b. Written résumés showing not less than one year of acceptable experience with explosives under a qualified licensed blaster.
3. At least 5 days prior to any blasting, the Contractor shall submit a blasting plan to the City Utility Engineer or his representative. If unanticipated rock is encountered the City may approve starting the blasting in less than 5 days from the submittal of the blasting plan. The blasting plan shall include the following items:
- a. A description and license number of the vehicle to be used for transportation of explosives, routes to be traveled and proposed hours of travel, and qualifications of driver.
 - b. Type of explosives, initiation system, drilling system, loading plan, firing plan, pre-blast and post-blast inspection, handling of misfires, and removal and disposal of excess explosives.
 - c. Proposed signs, guard system, signal system, methods of communication, pre-blast notification of affected agencies or entities and traffic control measures during blasting.
 - d. Copies of all required permits and licenses.
4. The safety of personnel shall be the primary consideration in decisions involving use of explosives. Protection of vehicles, utilities, and adjacent property from ground motion or fly-rock must also be provided. Use of blasting mats and other protective devices will be required. The Contractor shall retain sole responsibility for repairing or replacing any utilities or property damaged as a result of his blasting operations. Due to the proximity of residences and vehicular traffic, use of controlled blasting techniques is specifically required. A delayed blasting system shall be utilized that will not allow more than two holes to detonate simultaneously. Blasting will only be allowed during times of low traffic on the adjacent roads and only in conjunction with traffic closure for the period of time during which blasting occurs. Traffic closure must be approved by the Engineer.

103.12 Stockpiling Excavated Material.

Excavated material shall be piled in accordance with OSHA guidelines in locations that will not endanger the Work, create traffic hazards or obstruct sidewalks and driveways. Fire

City of Grand Junction, Colorado
Standard Specifications for the Construction of Underground Utilities

hydrants, valve boxes, manholes and other utility access points shall be left unobstructed. Gutters and other watercourses shall not be obstructed unless other satisfactory provisions are made for runoff and street drainage.

All surplus material and excavated material unsuitable for backfilling shall be removed from the site and disposed of in areas secured by the Contractor.

103.13 Dewatering Trenches.

No groundwater dewatering operation shall begin until a Construction Dewatering Permit has been obtained from the Colorado Department of Health and Environment (CDPHE). This permit may be obtained by the City and transferred to the Contractor or the City may require the Contractor to apply to the CDPHE for the permit. The dewatering permit may be waived when 100 percent of the groundwater removed from the excavation is used for on site dust control or other land application approved by the City and the CDPHE.

In addition to a Construction Discharge Permit, no groundwater shall be discharged to a street, sanitary sewer, storm drainage system, drainage ditch, irrigation ditch, pipe or other facility without written permission from the City and the owner of the receiving facility, if other than the City.

Trenches shall be kept free of water during pipe laying operations by draining, pumping or other approved methods. The water level shall be maintained at least six (6) inches below the trench bottom throughout the placement of bedding, pipe laying, joining and backfilling operations. The dewatering shall be carried out so that it does not destroy or weaken the strength of the soil under or along the side of the trench. Watertight plugs shall be installed in the ends of all water and sewer lines when the trench is not being dewatered. Surface water from any source shall be prevented from entering the trench excavation. No additional payment will be made to the Contractor due to an unstable trench or pipe foundation conditions caused by surface water entering the trench.

103.14 Backfilling Pipe and Structures.

Unless otherwise specified or approved by the Engineer, all backfill material shall be placed with moisture-density control in accordance with the typical trench detail shown on the *City Standard Drawings*. All backfill material shall be adjusted to within two percent (2%) of the optimum moisture content prior to its placement in the trench. Jetting or water soaking trenches to achieve compaction of the backfill will not be permitted except when: 1) soil sample tests show that the backfill and excavated trench materials consist of gravel or other granular material having less than 15 percent by weight passing a No. 200 sieve; and 2) the Engineer has given written approval prior to water soaking.

A minimum of 24 inches of compacted backfill shall be placed over the top of all polyvinyl chloride (PVC) and polyethylene (PE) pipe before vehicles or heavy equipment are allowed to pass over the pipe. Less cover may be allowed only where *flow-fill* or other approved material is used for the initial backfill above the pipe spring line. Flow-fill shall meet the requirements of Section 206.02(a) of the *Standard Specifications for Road and Bridge Construction*.

During initial backfilling, the Contractor shall take all necessary precautions to prevent movement or distortion of the pipe or structure being backfilled. Pipe haunch backfill material shall be placed and compacted in even lifts on both sides of the conduit to six (6) inches above the top of the pipe. Above the bedding and haunch material, earth backfill

City of Grand Junction, Colorado
Standard Specifications for the Construction of Underground Utilities

material shall be placed full width in uniform layers not more than twelve (12) inches thick. Each layer shall be compacted to the required density with approved mechanical or hand tamping equipment. Hydro-hammers or other heavy compaction equipment shall not be used unless approved by the City Utility Engineer. No hydro-hammer shall be used for compaction with less than 48 inches of cover over the pipe.

Surface water from any source shall be prevented from entering the excavation. No additional payment or extension of contract time will be made to the contractor due to saturated or unstable conditions caused by surface water entering the excavation.

All backfill shall be frequently tested to insure that the required density is being attained. For every 400 lineal feet of trench and each branch or section of trench less than 400 feet in length, at least one compaction test shall be performed for each two-foot vertical of depth of backfill material placed. The first test shall be taken approximately two feet above the top of pipe and the last test shall be at the pavement subgrade or 6 inches below the ground surface in unpaved areas. Compaction tests shall be taken at random locations along the trench and wherever poor compaction is suspected. If any portion of the backfill placed fails to meet the minimum density specified, the failing area shall be defined by additional tests, if necessary, and the material in the designated area shall be removed and replaced to the required density at the Contractor's expense.

If full-time inspection is provided during the backfilling operation by a WAQTC or NICET Level 2 certified technician, and sufficient initial testing has been performed to demonstrate that the methodology being used achieves the required results, then the frequency of compaction testing may be reduced as shown in Table 101. The methodology shall be verified for each soil type or trench condition encountered.

It shall be the Contractor's responsibility to make necessary excavations and to provide safe access into the excavations in accordance with OSHA Standards in order to accommodate compaction tests at all locations designated by the Inspector or authorized Technician.

Failed compaction tests shall be immediately reported to the Inspector and the Contractor. A summary report of all compaction test results, including retests of failed tests and a test location map or other approved location format shall be submitted to the Project Engineer and to the Contractor. Compaction test results are required as a basis of acceptance of facilities by the City in accordance with Section 107.1.

Manholes, storm inlet boxes and other concrete structures shall not be backfilled until the concrete and mortar therein has attained a minimum compressive strength of 2000 psi and can sufficiently support the loads imposed by the backfill. Backfill shall consist of approved materials uniformly distributed in layers brought up equally on all sides of the structure. Each layer of backfill shall not exceed 8 inches before compacting to the required density and before successive layers are placed. Each layer shall be compacted to not less than ninety-five percent (95%) of the maximum density determined in accordance with AASHTO T-99 or 90% of the maximum density in determined accordance with AASHTO T-180 as determined by the Engineer. All backfill placed within two (2) feet measured horizontally from any structure shall be compacted with hand operated mechanical equipment.

103.15 Granular Stabilization, Bedding and Haunch Backfill Materials.

Granular materials required for stabilization of poor subgrade soils, bedding of pipe and structures, and haunch backfill around pipe shall meet the following gradation requirements:

Sieve Size	Percent passing, by weight	
	Pipe bedding & haunch (crushed rock) Type A	Granular Stabilization (crushed rock) Type B
	2 inch	- - -
1 inch	100%	- - -
#4	20% max.	15% max.

Crushed rock shall be the product of crushing rock and/or gravel. The portion of the material retained on a #4 sieve shall contain at least 50 percent of particles having two or more fractured faces when tested in accordance with CP45-98. Not over 5 percent shall be pieces that show no fractured faces.

103.16 Earth Backfill Material.

Earth backfill material shall consist of approved materials developed from project excavations or imported from another source. To be suitable for backfill, earth or earth and rock material shall be free from muck, frozen lumps, ashes, trash, vegetation and other debris. All excavated materials which, in the opinion of the Engineer, are unsuitable for use in the backfill shall be removed from the site and disposed of by the Contractor at his expense. The maximum size of rock or clod allowed within 6" of any plastic pipe shall be one (1) inch. The maximum size of rock or clod allowed within 6" of a rigid pipe or structure shall be three (3) inches.

Testable Materials: Any soil or soil and gravel mixture having at least 70% passing the 3/4" sieve and at least 50% passing the #4 sieve.

City of Grand Junction, Colorado
Standard Specifications for the Construction of Underground Utilities

Pitrun Backfill: Pit-run, crushed asphalt pavement or other material which is “too rocky to test” the in-place density using standard AASHTO or ASTM procedures, shall conform with the following requirements :

Maximum Particle Dimension	12"
Percent passing No. 4 sieve	20% min.
Percent passing No.200 sieve	20% max.
Plasticity Index (PI)	7 max.

In addition to the above requirements, the Engineer and/or the Construction Inspector shall have the authority to determine, by visual inspection, if the material delivered to the job site contains a sufficient quantity of fine graded material to fill the voids between rocks

when the material is placed and compacted. Material that is segregated, contains too much cobble or otherwise unsuitable for use in the backfill shall be removed from the job site or blended with other suitable material as directed or approved by Engineer or his representative.

Pit run and crushed asphalt are typically found to be “too rocky to test” using standard density test procedures, therefore, the Contractor shall prepare and submit a Construction Procedure Plan for approval by the City. The plan shall describe the equipment, methods and procedures that the Contractor shall use to place and compact the material. The City may require that the contractor demonstrate the proposed procedures before approval is given. The Construction Procedure Plan shall include the following:

- 1) Source(s) of the proposed backfill material.
- 2) Equipment to be used for placement and compaction of the material:
- 3) Description of how moisture content of the material will be tested and, if necessary, adjusted.
- 4) Description of methods that will be used to place the material in the trench or excavation including the maximum lift thickness to be placed and compacted.
- 5) Description of the method of compaction including equipment to be used.

Construction Inspection. When the embankment or backfill material is too rocky to test, the City requires full time inspection and observation during the placement and compaction of the material to assure compliance with the approved Construction Procedure Plan. For non-City managed projects, the Inspector shall have be NICET Level II certified in construction

materials or highway construction and shall be employed by an independent laboratory or consulting engineering firm.

Moisture Content Monitoring. The pit run material shall be sampled and tested for moisture content at the same frequency specified in section 103.14 for compaction testing. Samples for moisture content tests shall be randomly taken from the material being placed. The moisture content of the material shall not deviate from optimum on the dry side by more than two percentage points as determined by AASHTO T 99 or T 180. Moisture content testing shall be performed by the Inspector or by an independent laboratory at the owners expense.

Proof Rolling. The Engineer or Construction Inspector may require proof rolling of the compacted pit-run aggregate to test for deflection. The Contractor shall furnish a rubber-tired, self-propelled vehicle for proof rolling. If while proof rolling, any visible deflection or rutting is observed, additional compaction of the pit run aggregate will be required.

103.17 Restoration of Grounds.

The cleanup and restoration of grounds shall be a continuous process from the beginning of construction to final completion of the Work. The Contractor shall keep the work site free from accumulation of debris and waste material caused by his operation.

After the pipeline is backfilled, the area shall be cleaned and restored to the original grade and condition. Final stabilization and restoration of grounds shall be in accordance with the Storm Water Management Plan (SWMP). Erosion control measures shall be installed and maintained until the required vegetative cover is reestablished. The cleaning and restoration shall be kept up to no greater than 500 feet behind the backfill operations unless the *Construction Drawings* or *Contract Documents* indicate otherwise. All fences, utilities, culverts, ditches, structures, grassed areas and plantings shall be replaced and restored to a condition equal to or better than that at the beginning of construction. In the case of point-location work to be performed later in the construction process, such as water line tie-ins, the restoration (but not the clean up) of the area adjacent to the point-location may be delayed until the point-location work is performed.

103.18 Restoration of Paved Surfaces.

The Contractor shall replace all paved surfaces removed or damaged by his operation. All paving, patching, aggregate base course and concrete replacement work shall be in accordance with the *Standard Specifications for Road and Bridge Construction* (see section 401.04.14 for asphalt patching).

The restoration of asphalt and concrete surfaces and structures shall be performed at the completion of each segment of the project (including all required testing) unless otherwise specified or approved by the Engineer. A segment is defined as one contiguous length of pipe installed. Trenches in residential streets may be repaved as a single operation after all pipe and appurtenances have been installed, tested and accepted unless otherwise specified.

City of Grand Junction, Colorado
Standard Specifications for the Construction of Underground Utilities

Prior to paving or patching all pavement edges that have been broken, raveled or otherwise damaged shall be re-cut to a neat line in accordance with subsection 202.09 of the City's *Standard Specifications for Road and Bridge Construction*.

103.19 Erosion Control

Erosion control measures shall be constructed, installed, maintained, moved (if needed) and removed in accordance with the project Storm Water Management Plan (SWMP), the CDPHE Construction Permit (if any) and Section 208 of the CDOT Standard Specifications for Road and Bridge Construction as amended by the City's Standard Specifications for Road and Bridge Construction. Erosion control measures shall be maintained during the life of the Contract to prevent or minimize erosion, sedimentation, and pollution of any state waters and wetlands.

SECTION 104 - INSTALLATION OF PIPE AND APPURTENANCES

104.1 Description.

All pipe, valves, hydrants, manholes and other pipeline appurtenances shall be installed and tested in accordance with these specifications and manufacturer's instructions. When installation instructions or procedures differ, the Engineer will determine which will take precedence over the others.

104.2 Installation of Gravity Flow Pipelines.

Gravity flow pipelines covered by this specification include: sanitary sewers, storm drains, culverts and non-pressurized irrigation lines. All sanitary sewer facilities shall be in compliance with design criteria of the Colorado State Department of Health.

104.2.a Laying Gravity Flow Pipe

After the trench has been de-watered and the bedding prepared in accordance with Section 103, the pipe shall be laid to the line and grade shown on the Construction Drawings. Variance from the designed location and elevation at the ends of every pipe section shall not be greater than three (3) inches horizontally and two (2) inches vertically while still maintaining minimum positive slope of the pipe. Variance from the design slope shall be within $\pm 0.04\%$ of the design slope. At no point, however shall the slope be permitted to drop less than the allowed minimum positive slope of 0.40% or the design slope shown on the Construction Drawings, whichever is less. A deflection of up to 0.8 inches, creating a sag of not longer than 4 linear feet, will be allowed once in every 100 feet of pipe laid. If a sag is identified during lamping the sewer line, the line will be televised, closed caption, in accordance with Section 105.2b to determine the severity of the deficiency.

The Contractor shall set the line and grade of each joint of pipe with a laser unless otherwise approved by the Engineer. Offset hubs shall be set by the Contractor's surveyor at intervals of 25', 50', 100' and 200' out of each manhole, inlet box, or starting point to verify vertical and horizontal line and grade of the gravity pipe being installed. Control stakes shall include station information for the horizontal control. Whenever the pipe is found to be outside the specified limits, the misaligned sections shall be removed and relayed to the correct line and grade at the Contractor's expense.

Pipe shall be laid upgrade from the point of connection to the existing sewer or from a designated starting point. Pipe with bell and spigot joints shall be laid with the bell end upgrade.

The inside of the pipe and jointing surfaces shall be kept clean and free from mud, soil, gravel, groundwater, and other foreign material. When pipe laying is not in progress, the upgrade end of the pipe shall be kept closed with a tightly fitting cap or plug.

For storm drain applications, approved end sections are required at the exposed ends of all polyethylene and PVC pipe, to protect the pipe from prolonged exposure to ultra violet radiation and from damage due to burning.

City of Grand Junction, Colorado
Standard Specifications for the Construction of Underground Utilities

Sewer Line Stub Outs. All sewer line stub outs longer than 10 feet shall terminate at a manhole, unless otherwise approved by the City Utilities Engineer. The minimum length of a stub out shall be 18". Each stub out shall be connected to the manhole with a Kor-n-seal gasket, or approved equal, and plugged with a PVC cap that can be removed for future extension, yet still prevent ground water infiltration. The manhole base shall be formed to provide positive flow through the manhole from the inverts of all connecting pipes, including stub outs.

104.2.b Installation of Sewer Service Lines.

Sewer service pipe within the public way shall be laid at a minimum grade of one-fourth (1/4) inch per linear foot unless otherwise approved by the Engineer. Flatter slopes between one-eighth (1/8) and one-fourth (1/4) inch per foot will be allowed only when there is not enough elevation difference to achieve one-fourth (1/4) inch per foot. Sewer service pipe and connections to the sewer main shall be inspected by a Department of Public Works, City Inspector prior to backfilling. The location and alignment of service lines shall be established by the Engineer. All sewer service lines shall have a clean-out installed per Standard Detail for Service "Y" Connection, page SS-06

The maximum deflection permissible at any one fitting or any combination of adjacent fittings shall not exceed 90 degrees. 90 degree fittings shall be the long radius type.

Small Diameter Taps. 4" service lines shall be joined to the new sewer mains with a wye fitting connected above the spring line of the sewer pipe. On existing PVC sewer mains the method of connection may be by the installation of a PVC tapping saddle with stainless steel straps. Where a tapping saddle is used, the hole in the main line shall be elliptical and slightly larger than that in the tapping saddle. The service line or wye shall not protrude beyond the inside wall into the sewer main.

Large Diameter Taps. All 6" or larger service taps shall be accomplished using a manhole. On 8" or smaller main lines in which projected flows will be less than 1/3 full, the 6" service line shall enter the manhole approximately 0.2' higher than the invert of the existing pipe. On larger mains, the 6" line shall be placed vertically so that flow from the main line does not back into the service line.

All taps. On existing non-PVC main lines such as concrete or clay, Inserta Tees, as specified in Section 102.9 shall be used in accordance with the manufacturer's recommendations. Verify that the supplied tee is intended for the diameter and type of the existing pipe. At no point shall the tee protrude more than 1/2 inch into the existing pipe.

For the installation of sewer service lines to properties that will not be immediately connecting or reconnecting to the sewer system, the service lines shall be stubbed out to the house side of the multi-purpose easement, utility easement or right-of-way line where no easement exists. The end of the pipe shall be plugged and marked with either a 4" x 4" wood post or steel fence post buried vertically above the end of the pipe and extending 3 feet above the ground surface with the exposed portion painted green. The ends of the service lines shall be capped with watertight plugs braced to withstand test pressures. The horizontal location of each service tap shall be measured and shown on the As-Built drawings PRIOR to backfilling. The Contractor shall mark the end of the service with a post, as required above, with a reference mark and depth to the service pipe to be shot (for elevation) and documented at a later date. Tap locations shall be referenced using the stationing shown on the plans or referenced to property corners unless otherwise approved by the Engineer.

City of Grand Junction, Colorado
Standard Specifications for the Construction of Underground Utilities

Where a PVC sewer service line is connected to an existing service line, the connection shall be made with a Calder® coupling, or approved equal, of the style or with the adapters to be compatible with the pipes being joined. The coupling shall be encased in concrete. An alternative would be to use Mission type couplings with stainless steel bands. Mission type couplings need not be encased in concrete.

All service lines over 100 feet in length have a clean-out installed in accordance with the Uniform Plumbing Code. When the clean-outs are located within the right-of-way, they shall be terminated in a cast iron ring and cover suitable for traffic loads as shown on the *City Standard Detail SS-07*.

Sub-drains and/or French drains will not be permitted to be connected to sanitary sewers.

Services for service stations, car washes, food-processing establishments shall have a grease and/or sand trap installed on their service lines. The trap shall be constructed to the requirements of the Persigo Industrial Pretreatment Coordinator.

104.2.c Construction of Manholes.

The foundation for each manhole base shall be prepared by replacing unsuitable material with subgrade stabilization material in accordance with Section 103.8, and placing granular bedding material in accordance with the *City Standard Drawings*.

The manhole base shall be precast or cast-in-place. The lines and grades of the pipe inverts shall be staked, as shown on the *Construction Drawings*. The inverts of sanitary sewer manholes shall be formed and smoothly finished to match the shape and elevation of all pipes connected to the manhole. Where the sewer line is designed with a continuous grade through the manhole, the pipe shall be laid through the manhole location, the top half of the pipe cut out and the manhole base formed around the bottom half of the pipe. A pre-cast base with a pre-cast invert may be used where there is at least 0.2 ft. of elevation difference across the manhole.

Sanitary sewer manholes inverts constructed with less than 0.16 ft. of elevation drop from pipe invert in to pipe invert out, and not constructed with the sewer pipe laid through the manhole as described above, shall be coated with an epoxy gel material as specified in Section 102.11. The concrete invert shall be formed or removed to a depth to allow room to apply the epoxy coating to match to pipe invert and maintain positive fall through the manhole. The cured surface of the epoxy coating shall be smooth, free of trowel marks and shall have a cross section consistent with that of the PVC pipe.

All drop manholes, force main outlet manholes, lift station wet wells and other structures that will be exposed to raw sewage, shall be coated on the interior surfaces in accordance with Section 102.11.

Water-stops shall be installed on all pipes going into or out of a cast-in-place base. Water-stops shall be placed on both the uphill and downhill sides of the manhole on pipes laid continuously through a manhole. For precast bases the pipes shall be connected to the base with flexible rubber boots with stainless steel straps.

If cast-in-place bases are used, the first pre-cast manhole section shall be placed on the concrete base structure before the base has taken initial set, or the section shall be grouted into a suitable groove formed in the top of the manhole base. The first section shall be adjusted to the proper grade and alignment so that it is uniformly supported by the base concrete and not bearing on any of the pipes. The manhole barrel sections and cone shall

City of Grand Junction, Colorado
Standard Specifications for the Construction of Underground Utilities

be positioned so that the steps and access hole are in alignment and at a 45 degree angle from the inflow pipe (measured from the center of the manhole). The pre-cast sections shall be placed and aligned to provide plumb vertical sides. The top of the cone section shall not be more than eighteen (18) inches below the finished grade elevation. A bitumastic or other approved sealer shall be placed between pre-cast sections so that the completed manhole is rigid and watertight. The sealer shall be placed both on the inside lip as well as the outside lip of each section.

The manhole ring and cover shall be set to match the adjacent ground or pavement surface. Concrete grade rings shall be dry stacked to within two (2) inches of the bottom of the cast iron ring elevation. The cast iron manhole ring shall be set to the final pitch and elevation with shims or other approved devices. The space between the top grade ring and the cast iron manhole ring shall be filled with QUIKRETE® Rapid Road Repair (No. 1242) or an approved equal.

Cast iron grade adjustment (extension) rings are allowed to adjust the elevation of the manhole covers, only when a street is being overlaid. Inverted rings and covers will not be permitted without the approval of the City Utility Engineer.

Where the manhole is located in an unpaved street, alley or other area where grade has not been established, 6 to 12 inches of grade rings shall be placed between the top of cone and bottom of the CI ring (to allow future adjustment of the ring to grade).

Where the manhole is located in an unpaved area, a concrete collar with a #4 rebar hoop shall be cast around the ring and cover, and shall extend a minimum of 4" below the top of the concrete cone. The concrete collar shall be a continuous section with minimum dimensions of 12 inches wide and 12 inches thick.

Where a manhole is in a cultivated or landscaped area, a watertight manhole cover shall be used. In cultivated areas, the top of the casting shall be 18 to 24 inches below the existing ground surface.

All newly constructed manholes shall be cleaned of any accumulation of silt, debris, or foreign matter of any kind, and shall be free from such accumulations at the time of final inspection. All ram-neck shall be trimmed flush with manhole wall.

104.2.d Construction of Storm Inlets, Vaults and Irrigation Structures.

Precast concrete boxes for storm inlets, vaults and irrigation structures shall be placed on prepared granular bedding, uniformly supported, in correct alignment and at proper grade.

When the box is furnished in more than one section, the sections shall be joined and sealed with mortar or an approved bitumastic material so that the completed box is rigid and watertight.

Pipe connections to concrete structures shall result in a smoothly finished, watertight connection. If the pipe is PVC or polyethylene with a smooth exterior, a water-stop shall be installed on the end of the pipe and the pipe grouted into the structure or a flexible boot connector shall be installed with stainless steel straps. Pipe ends shall not extend more than one inch beyond the inside face of the structure.

City of Grand Junction, Colorado
Standard Specifications for the Construction of Underground Utilities

Cast iron frames shall be adjusted to grade with wedges or shims to assure accurate placement. The frame or grade ring shall be set in a full mortar bed in its final position.

All inlet boxes, vaults and irrigation structures shall be cleaned of any accumulation of silt, debris, or other foreign matter and shall be free from such accumulations at the time of final inspection.

104.3 Installation of Pressure Pipelines.

Pressure pipelines covered by this specification include: water lines, force mains, siphons, pressurized irrigation lines and other lines that operate under a hydraulic head.

104.3a Laying Pressure Pipe

Water lines, force mains and other pipelines that will operate under pressure shall be laid on the alignment shown on the plans. Unless otherwise specified or approved, all pressure pipelines shall be laid to a depth to provide a minimum cover of 48 inches measured from the final ground surface to the top of the pipe. Pressure pipelines placed in service before final surface grading has been completed shall have a minimum cover of 36 inches during the winter season.

The inside of water pipe and jointing surfaces shall be kept clean and free from mud, dirt, gravel, ground water, and other foreign material. Whenever dirt or debris enters the pipe, the Contractor shall clean the pipe by swabbing or other approved method (see Section 4.3 of Appendix A). After cleaning, the City Inspector shall determine if the pipe is clean enough to be installed. When pipe laying is not in progress the open ends of the pipeline shall be kept closed with watertight plugs.

Long radius horizontal or vertical curves may be laid with standard pipe by deflections at the joints of rigid pipe or by deflecting the entire length of flexible pipe. Maximum deflections at pipe joints shall be per the Manufacturer's recommendations or applicable AWWA Standard.

104.3b Electrical Continuity.

All water mains and other pressure pipelines shall be buried with a continuous electrical tracing wire to enable future location of the pipe. Tracing wire shall be taped to the top of the pipe at 10-foot intervals to prevent dislocation of the wire during backfilling. The tracing wire shall be spliced and extended to the top of the southerly most valve box in each street intersection and to the base of all fire hydrants as shown on the *City Standard Drawings W-09 and W-10*. On water transmission lines or mains not located in streets, the tracing wire shall be extended to the top of each gate valve box and the isolation valve box at each air release valve as shown on *City Standard Drawing W-11*. ~~The wire shall be installed on the outside of the lower section of each valve box and inside of the upper section to the lid.~~ Tracing wire shall be terminated at the ends of all pressure pipelines as detailed on *City Standard Drawing W-09* Tracing wire shall be spliced with a wire nut, wrapped with ~~Aqua-Seal~~ TBT-20 rubber tape to completely encase the connection, with an exterior wrap application of plastic electrical tape.

All ductile iron pipe with push on type joints shall be electrically connected with wedges or with cadweld connectors and No. 10 copper wire. The wire ends and cadwelds shall be sealed to prevent corrosion.

104.3c Polyethylene Encasement.

Prior to backfilling, all non-epoxy coated cast iron and ductile iron pipe, fittings, valves, appurtenances and all other metal pipes and fittings, except copper service lines, shall be wrapped with polyethylene encasement material. Polyethylene film shall have a minimum thickness of 0.008 inches (8mil). Installation of the polyethylene encasement shall be in accordance with one of the methods described in AWWA C-105. If a soil survey has been performed in accordance with Appendix A of AWWA C-105 and the soil is found to not be corrosive to ductile iron, then the Project Engineer or the Contractor or may submit a written request to the City Utilities Engineer to install ductile iron pipe and fittings without a polyethylene encasement.

Ductile iron valves and fittings shall be fully encapsulated by the polyethylene encasement, except the valve operating nut. The ends of the polyethylene shall be taped around the full circumference of the pipe. If the polyethylene is cut or more than one piece is used to wrap the valve or fitting, the pieces shall overlap a minimum of 12 inches and the full length of the seam shall be taped.

104.3d Thrust Restraint.

Thrust restraint shall be provided at all pipe bends, tees, caps, valves, hydrants and at the end of all stub outs or dead end lines. Thrust restraint beyond the physical fitting may be provided by concrete blocking or mechanical restraint of pipe joints. If pipe joint restraint is used in lieu of concrete thrust blocks, the minimum distance for joint restraint along the pipe away from the fitting shall be determined utilizing EBAA Iron Thrust restraint calculations. This is available on line at [http://rcp.ebaa.com/ Restraint Length Calculator v5](http://rcp.ebaa.com/Restraint Length Calculator v5). In-line valves with a minimum of 20 feet of pipe are not required to be separately restrained.

Concrete Blocking. The size and location of concrete blocking shall be as shown on the plans or in accordance with the *City Standard Drawings*. Thrust blocks shall be poured on firm, stable foundation material and all bearing surfaces shall be against undisturbed earth.

Concrete for thrust blocks shall be made with modified Type II Portland cement and shall reach a minimum compressive strength of 3000 psi in 28 days. Reinforcing steel and bolts used to anchor valves, fittings, etc., to thrust blocks shall meet tensile requirements of ASTM Grade 40. All anchorage steel not embedded in concrete shall be factory epoxy coated or Cor-Ten steel.

Fire hydrants shall be dry blocked as well as mechanically restrained, as shown on the *City Standard Drawings*.

Mechanical Restraint. Valves and fittings may-shall be restrained by mechanically connecting them to the pipe or other fittings in accordance with Section 102.8c.

104.3e Installation of Gate Valves and Valve Boxes.

Each gate valve shall be installed in a vertical position and set on a concrete support block as shown on the *City Standard Drawings*. An adjustable slip type valve box shall be set into position during backfilling operations. The upper section of the unit shall be placed in proper alignment and adjusted so that its top will be at final grade. The completed valve box shall be vertically centered over the valve operating nut. Each valve shall be checked for proper access and operation prior to paving.

104.3f Installation of Butterfly Valves.

Unless otherwise approved by the City Utilities Engineer, each butterfly valve shall be installed in a vault. The diameter of the vault shall be as detailed on the plans.

104.3g Installation of Fire Hydrants.

Hydrants shall be installed at the locations shown on the *Construction Drawings*. They shall be plumb and set so that the bottom of the pumper nozzle is no less than eighteen (18) inches and no more than twenty-two (22) inches above finished grade. The depth of the water line shall be adjusted so the fire line, from the main to the hydrant, can be installed horizontally and the fire hydrant set with the ground line within ½ inch of the finished ground level. If the depth of the water line cannot be adjusted because of conflicting utilities or other constraints, an offset shall be installed on the fire line and rotated to achieve the proper bury depth of the hydrant or fire hydrant with a different barrel height shall be used.

A minimum of 1/4 cubic yard of washed gravel shall be placed around the base of the hydrant to insure proper drainage of the hydrant after use. All pipe and fittings between the water line and the fire hydrant shall be restrained with dry concrete thrust blocks behind the hydrant and mechanical restraints. The tee shall be restrained with concrete thrust block. Weep holes, which drain the hydrant, shall not be covered with concrete.

104.3h Installation of Water Service Pipe.

Where possible, underground water service pipes shall be laid not less than ten (10) feet horizontally from the building sewer drain. Where this separation is not possible, the service line shall be at least eighteen (18) inches above the top of the building sewer line. If placed in a common trench with the sewer service, the water service line shall be on a solid shelf excavated to one side of the trench. Where a sewer service is proposed with less than 5 feet of cover, the water service line shall be constructed in a separate trench and the sewer service line shall be constructed with Schedule 40 PVC pipe.

Water services on ductile iron pipe shall be direct tapped. Tapping saddles shall be used on PVC pipe. Taps shall be at 45° above the spring line of the pipe. If the tap is made while the main line is in service, a corporation stop shall be installed in the tap and turned so the T-handle will be on top. If the tap is made when the main line is not in service and the meter setter and the service line from the tap to the meter setter are installed before the main line is activated, it is not necessary to install a corporation stop.

Service Stub Outs. The service line shall be installed from the main to the meter pit location shown on the *Construction Drawings* or designated by the Engineer. A City furnished meter pit shall be installed so the top of the pit is within ½ inch of the proposed final ground surface elevation. The top of the pit shall be higher than the back of the adjacent sidewalk with a minimum slope of ¼ inch per foot from the pit to the back of the sidewalk. A City furnished meter setter shall be installed in each meter pit so the top of the setter will be 20 inches (+/- 2") below the top of the pit.

The service line shall extend to the back of the multipurpose or utility easement and marked either by a 4"x 4" board or steel fence post buried vertically. The board or post shall extend 3 feet above the ground surface with the exposed portion painted blue. The end of the service line shall be capped with watertight a plug.

Installation on non-City water systems shall conform to the standards of that particular system. Meters will be installed by the company or organization operating the water main.

Backflow Prevention Devices. Vacuum breakers shall be required on all irrigation sprinkler systems, and any other connection to the service line, which presents a backflow or siphon potential, and contamination risk. All backflow prevention devices shall be installed in accordance with the Uniform Plumbing Code and manufacturer's recommendations. For water services to medium and high risk installations, the assemblies shall be reviewed and approved by the City Utility Engineer, or designated representative, prior to installation.

Service Line Replacements and Reconnections. Existing lead and galvanized steel water service lines shall be replaced with approved water service line materials as specified in section 102.7C. Other service lines may be replaced as directed by the City. The new service lines shall be connected to the existing meter with the appropriate fittings. Excavation of the existing meter pit shall be done in a careful manner to keep the pit intact for continued use.

Water services to be relocated shall be carefully excavated and disconnected to preserve the integrity of the pit, meter and components. The relocated meter shall be reconnected to the customer's service line with the appropriate fittings.

For all service line reconnections and relocations the condition and configuration of the existing meter, fittings and pit shall be inspected by the City. The City may direct any or all of the components to be replaced or reconfigured to conform to current standards.

104.3i Connections to Existing Mains.

New water lines shall not be connected to existing mains in service until the new lines have been tested, disinfected, and accepted by the City.

Where the connection of the new lines to old requires interruption of service, the Engineer and Contractor shall mutually agree upon a date and time for connections which will allow ample time to assemble labor and materials. The Contractor shall notify all water users affected in accordance with the *General Contract Conditions*.

104.4 Relationship Between Water Lines and Sanitary Sewers.

To reduce the possibility of contamination of the domestic water supply in the event of a water line break or repair, the following construction techniques shall be used when a water line and a sanitary sewer line are installed in close proximity to each other. These requirements shall apply to main lines.

- 1) If the sewer line is above and within 10 feet horizontally of the water line, the sewer line shall be installed through a steel or ductile iron casing pipe or encased in reinforced concrete as shown on the *City Standard Drawings*. The casing pipe or concrete encasement shall extend a minimum of 10 feet on either side of the water line, measured perpendicular to the water line.
- 2) If the sewer line is 18" or less clear distance below and within 5 feet horizontally of the water line, the sewer line shall be installed through a steel or ductile iron casing pipe or capped with concrete as shown on the *City Standard Drawings*. The casing pipe or concrete cap shall extend a minimum of 10 feet on either side of the water line, measured perpendicular to the water line.

City of Grand Junction, Colorado
Standard Specifications for the Construction of Underground Utilities

In all cases, suitable backfill or other structural protection shall be provided to preclude the settling or failure of both pipes.

Crossings of sewer and water lines shall not be at an angle less than 45 degrees nor shall a sewer line or water line be installed within 10 feet of each other unless approved by the City Utility Engineer.

104.5 Relationship Between Raw or Potable Water Flow Line and Public/Private Utilities

To reduce the possibility of injury to workers in the event of an emergency repair, and to reduce possible damage to a City of Grand Junction flow line, the following construction techniques shall be used when a water flow line and public/private utility are installed in close proximity to each other. These requirements shall apply to any potable or raw water flow line that is 18 inches in diameter or larger.

- 1) A minimum clear distance of two (2) feet shall be required when the Utility is crossing either above or below the flow line.
- 2) The public-private Utility shall be encased in a steel casing pipe with minimum wall thickness of $\frac{1}{4}$ inch for a distance of twenty (20) feet centered on the flow line.

In all cases, suitable backfill or other structural protection shall be provided to preclude the settling or failure of both pipes. Crossings of Water Flow Lines and public/private utility lines shall not be at an angle less than 45 degrees.

SECTION 105 - PIPELINE TESTING

105.1 Testing.

All pipelines shall be tested before final acceptance. All testing shall be performed by the Contractor under direct control and observation of the Engineer or an approved independent laboratory, and a representative from either the Water Services Division or the Wastewater Services Division of City of Grand Junction Public Works and Planning Department. The Contractor shall furnish all labor, equipment, tools, water and other incidental items required to conduct the tests. City water is available for the contractor to use, provided that cross connection protection is used properly when connecting to the water system.

If a pipeline fails to meet the test requirements, the leak or other deficiency shall be located and repaired at the Contractor's expense. After the repairs or corrections have been made, the pipeline shall be retested. Repairs and retesting shall continue until the test requirements have been met.

105.2 Testing Sanitary Sewers.

All sanitary sewer lines shall be tested for leakage and alignment before acceptance.

105.2a Leakage Tests.

A leakage test shall be performed on all newly constructed sanitary sewers. The Contractor will determine which type of test will be made and shall furnish all labor, tools and equipment necessary to conduct the test. The allowable types of tests include exfiltration of water, exfiltration or air and infiltration of water.

Exfiltration of Water Test. The length of pipeline to be tested shall be limited so that the pressure on the lower end of the test section does not exceed ten (10) feet of water column. The test section shall be sealed off from the remaining pipeline with watertight plugs inserted in the pipes. The Contractor shall fill the pipe to the test level with potable water at least 24 hours prior to conducting the test. The test level shall be at least two (2) feet above the top of the pipe in the upper manhole or two (2) feet above the ground water table, whichever is higher.

Throughout the test period of at least one (1) hour, the water level shall be maintained at the test level and all water added shall be accurately measured. The exfiltration rate shall not exceed 0.15 gallon per inch of inside pipe diameter per hour per 100 feet of pipe length.

Exfiltration of Air Test. Air testing shall be in accordance with ASTM C-828. The ends of the test section shall be sealed at the upper and lower manholes with pneumatic plugs. One of the plugs provided shall have two taps. One tap will be used for introducing air into the pipeline through suitable valves and fittings so that the input air may be regulated. The second tap shall be fitted with valves and fittings to accept a pressure gauge to monitor the internal pressure of the sewer pipe.

City of Grand Junction, Colorado
Standard Specifications for the Construction of Underground Utilities

The pressure gauge shall meet the following minimum specifications:

Size 4-½ inch diameter
 Pressure range 0 - 15 psi
 Figure intervals 1-psi increments
 Smallest intervals..... 0.1 psi
 Pressure tube..... Bourdon tube or diaphragm

Connect the pressure gauge and air control equipment to the proper fittings and slowly apply air pressure. Pressurize the pipe line to 4.0 psig and throttle the air supply to maintain the pressure between 4.0 and 3.5 psig for at least two (2) minutes in order to allow equilibrium between air temperature and pipe walls. During this time check all plugs for leakage. If any plugs are found to leak, bleed off the air, tighten the plugs and re-pressurize the pipeline. After the temperature has stabilized, allow the pressure to decrease to 3.5 psig. At 3.5 psig begin timing to determine the time required for pressure to drop to 2.5 psig. The time, in seconds, for the air pressure to decrease from 3.5 psig. to 2.5 psig shall be greater than the minimum test time shown in the following table.

Nominal Pipe Size (inches)	Time (min/100ft)	Nominal Pipe Size (inches)	Time (min/100ft)
4	0.3	24	3.6
6	0.7	27	4.2
8	1.2	30	4.8
10	1.5	33	5.4
12	1.8	36	6
15	2.1	39	6.6
18	2.4	42	7.3
21	3.0		

In areas where the ground water level is above the pipe, the hydrostatic pressure of the ground water above the pipeline shall be determined and added to all test pressures (1 ft. of water = 0.43 psi). Air testing shall not be done if the groundwater level is greater than 10 feet above the sewer line.

Infiltration of Water Test. If the sewer line is in an area where the water table is two (2) feet or more above the pipeline, an infiltration test may be used. Infiltration tests shall be completed prior to placing new sewer lines in service. The infiltration of ground water will be measured with special made weirs, which will be inserted in the pipeline at manholes where flow is present. The infiltration rate shall not exceed 0.15 gallon per inch of inside pipe diameter per hour per 100 feet of pipe length.

105.2b Alignment Testing.

All sanitary sewer lines shall be observed for correct alignment by lamping. If the line does not pass the lamping test or if something other than crushed rock was used for pipe bedding, deflection testing shall be performed on flexible pipe or appropriate repairs shall be made on rigid pipe.

City of Grand Junction, Colorado
Standard Specifications for the Construction of Underground Utilities

Lamping Test. Lamping will be performed on all sanitary sewer pipe by the Engineer. All lines will be flushed at least 24 hours and no more than 48 hours prior to lamping. In order to pass the lamping test, no deformations or defects shall be observed in the pipe, the full vertical height of the pipe shall be observed and three fourths (3/4) of the pipe circle shall be observed horizontally.

For systems where a sewer line is allowed by the Utility Engineer to be stubbed out for a future extension without a manhole on the end, the trench shall be backfilled up to the end of the line but the end of the pipe shall remain accessible. The line shall be lamped from the open end of the pipe to the next downstream manhole.

Deflection Testing for Flexible Pipe. The maximum allowable deflection of flexible pipe shall be seven and one-half percent (7.5 %) of the Base Inside Diameter. The following values from ASTM D-3034 shall apply for SDR 35 PVC sewer pipe:

Nominal Pipe Size (Inches)	Base Inside Diameter (Inches)	Mandrel Diameter (Inches)
6	5.74	5.31
8	7.665	7.09
10	9.563	8.84
12	11.361	10.51
15	13.898	12.86

The deflection test will be performed by pulling a mandrel through the pipe from manhole to manhole.

Closed Caption Television (CCTV). The City will inspect all gravity sewer lines utilizing CCTV in order to evaluate any suspected or real deficiencies found during any of the above tests. All bored or microtunneled sewer lines shall be inspected by television. Any suspected sags, found during lamping of the sewer line, will be measured with a graduated device in front of the camera so as to eliminate any distortions that may be caused by the optics of the camera.

City managed projects: City will perform all CCTV work at no expense to the Contractor, provided that 72 hours notification is given.

Non-City managed projects: CCTV inspections must have a minimum of 5 working days notification. Developer/Contractor will be responsible for inspection costs incurred for private development work.

105.3 Testing Storm Drains, Culverts, and Gravity Irrigation Lines.

Leakage testing of gravity flow pipelines, other than sanitary sewers, is not required unless otherwise specified in the *Contract Documents*. All gravity flow lines including storm drains and culverts shall be tested for alignment in accordance with Section, 105.2.b unless otherwise approved by the City Utilities Engineer.

105.4 Testing Pressure Pipelines.

Water mains, force mains, siphons, irrigation systems and all other pipelines that will operate under pressure shall be tested for pressure and leakage in accordance with these specifications and AWWA C-600, Section 4. Although AWWA C-600 is for ductile iron pipe, the test procedures shall be used for PVC pipe also. Pavement or other permanent surfaces shall not be placed until all pressure and leakage tests are satisfactorily completed. If the section of pipe being tested includes components of an existing system or components installed by others, the testing shall be done so at the Contractor's risk.

Test Pressure. Unless otherwise specified, the test pressure for all pipes shall be double the maximum operating pressure at the lowest elevation of the test section or the class designation of the pipe plus fifty (50) psi, whichever is less. The minimum test pressure for water lines and sewer force mains, at the high point of the system, shall be one hundred fifty (150) psi.

The maximum operating pressure within the Grand Junction water distribution system is equivalent to the elevation difference between pipeline being tested and the water level at the Grand Junction water treatment plant, elevation 4813. The maximum operating pressure can be calculated as:

$$P = [4813 - \text{pipeline elev.}] \times 0.4335 \text{ (psi / foot of water)}$$

Filling. The pipeline shall be filled with potable water at least twenty-four (24) hours before being subjected to the hydrostatic pressure test. Each section of pipeline shall be filled slowly and all air expelled by means of taps at points of highest elevation. If temporary taps are installed to fill the line or release the air, the corporation stop shall be removed and the tap plugged when the disinfection and testing have been completed.

Procedure. Pressure and leakage tests may be performed simultaneously or separately. The total time for the combined pressure and leakage tests shall be a minimum of two (2) hours for each section of pipeline. If separate tests are made, the pressure test shall be made first. The duration of the pressure test shall be a minimum of one (1) hour and the duration of the leakage test shall be a minimum of four (4) hours. The pressure of the leakage test may be reduced to one hundred and fifty percent (150%) of the maximum operating pressure that will occur on that portion of the line.

Leakage is defined as the quantity of water to be supplied to the section of pipeline being tested, which is necessary to maintain the specified leakage test pressure after the pipe has been filled with water and the air expelled.

The specified test pressure shall be applied by means of a pump connected to the pipe in a manner satisfactory to the Engineer. No pipe installation will be accepted if the leakage for the section of the line being tested is more than the rate calculated using the following formula:

$$L = (N \times D \times \sqrt{P}) / 7400$$

Where:

- L = Allowable leakage in gallons per hour
- N = Number of joints in length pipeline tested
- D = Nominal diameter of pipe in inches
- P = Average test pressure in psi gauge

The allowable leakage rates for typical pipe sizes and pressures, based on 20-foot joint lengths, within the Grand Junction water distribution system are as follows:

City of Grand Junction, Colorado
Standard Specifications for the Construction of Underground Utilities

Allowable Leakage (gallons per hour per 1000 feet)					
-- Grand Junction water distribution system only --					
Pipeline Elev.	Test Pressure	6" pipe	8" pipe	10" pipe	12" pipe
4640 or higher	150 psi	0.50	0.66	0.83	0.99
4628 to 4640	160 psi	0.51	0.68	0.85	1.03
4617 to 4628	170 psi	0.53	0.70	0.88	1.06
4605 to 4617	180 psi	0.54	0.73	0.91	1.09
4594 to 4605	190 psi	0.56	0.75	0.93	1.12
lower than 4594	200 psi	0.57	0.76	0.96	1.15

SECTION 106 - DISINFECTION OF WATERLINES

106.1 Disinfection Standard.

All water mains shall be disinfected in accordance with AWWA Standard C651-05 including Section 4.6 – Final Connections to Existing Mains. The Standard is modified as follows:

Section 4.1: Forms of Chlorine Disinfection

Delete Subsection 4.1.3 Calcium Hypochlorite

Section 4.4: Methods of Chlorinating.

Add the following to Subsection 4.4.1:

The continuous feed method shall have a 24-hour chlorine residual of not less than **25** mg/l;

Delete Subsection 4.4.2 Tablet Method

Delete Subsection 4.4.2.1 Placing calcium hypochlorite granules

Delete Subsection 4.4.2.2 Placing calcium hypochlorite tablets

Subsection 4.5.3 Minimum Velocity of 7 ft/second.

Achieve 7 to 9 ft/sec for 3 minutes for every 100 feet of pipe. If discharging that much water is concern due to traffic or other constraints, the City of Grand Junction Pipeline Maintenance Division's flow diffusion box may be borrowed with at least 48 hours notification. A Pitot tube shall be used to verify velocities. The following table identifies the flow rate required to achieve 7 feet per second:

Line Size	Required Flow (gpm)
4	274
6	617
8	1097
10	1713
12	2467
14	3358
16	4387
18	5552

Flushing should be performed for a minimum of 3 minutes in order to allow at least 12 times the line's volume to be flushed through the system.

Subsection 4.5.4 Check Outfall Capacity.

Downstream sewer system capacity shall be verified with Persigo Wastewater Treatment plant personnel at least 72 hours PRIOR to discharging into it. Persigo staff will issue an "OK to Discharge Permit". This permit will be required to be onsite during flushing. Some locations may require the water lines to be flushed during periods of low sanitary flows. Below is a table showing the full pipe capacity of various sewer line sizes at minimum slope:

Line Size	Slope	Capacity (cfs)	Capacity (full) GPM
6	0.4	0.36	161
8	0.4	0.76	341
10	0.28	1.16	520
12	0.29	0.189	848
15	0.2	2.9	1301
18	0.2	4.71	2113
21	0.2	7.1	3186
24	0.2	10.14	4551

The above capacities are full pipe capacities. Therefore if the pipe is already half full, the available capacity would be half that stated above if the line is on minimum slope.

If downstream capacity is a constraint, the high chlorine water shall be flushed into the sewer at a slow rate until the chlorine content reaches 1.5 mg/l or less. Then, an alternate discharge point such as a storm drain, drainage channel, borrow ditch or neighboring field with owner's permission, shall be found to discharge the high flow rate flushing described in Subsection 4.5.3. This shall be accomplished in accordance with Subsections 4.5.1 and 4.5.2 (see Appendix A).

Subsection 5.1.1 Standard Conditions

Replace entire paragraph with the following:

After final flushing and before the new water main is connected to the distribution system, **two** consecutive sets of acceptable samples, taken at least 24 hours apart, shall be collected from new main. (NOTE: The pipe, the water loaded into the pipe, and any debris all exert a chlorine demand that can interfere with disinfection.) At least one sample shall be collected from every 400 ft (122 m) of the new water main, plus one from each end of the line and one from each branch for each set of required samples. The second sets of samples are taken 24 hours after first set and prior to any additional flushing (sampling static water after 24 hours). All samples shall be tested for bacteriological (chemical and physical) quality in accordance with *Standard Methods for the Examination of Water and Wastewater*, and shall show absence of coliform organisms: all samples shall have a minimum of 0.2 mg/l of chlorine residual. Turbidity, pH, and a standard heterotrophic plate count (HPC) test

City of Grand Junction, Colorado
Standard Specifications for the Construction of Underground Utilities

may be required at the option of the purchaser, because new material does not typically contain coliforms but does typically contain HPC bacteria.

Subsection 5.1.3 Sampling Procedures

Delete "or fire hydrant" from the second sentence.

Add the following:

Fire hydrants may be used at the Contractor's risk for the collection of samples, if the hydrant has been flushed and disinfected with the water line.

To coordinate with the City's laboratory schedule, bacteriological test samples may be taken Monday through Thursday on regular workweeks. No sampling shall be performed on holidays.

All samples shall be collected in the presence of a representative from the Water Services Division of City of Grand Junction Public Works and Planning Department.

SECTION 107 - FINAL INSPECTION AND ACCEPTANCE

107.1 Final Inspection and Acceptance.

The acceptance of all pipelines by the City will be based on the following:

1. Red-lined As-Built of sewer facilities including inverts on services are required PRIOR to paving.
2. Passing a final inspection of the Work by the City Utility Engineer or his representative and a representative from either the Water Services Division or the Wastewater Services Division of the City of Grand Junction Public Works and Planning Department .

3. Non-City Managed Projects.

- Submittal of all quality assurance test results in accordance with Table 101- REQUIRED QUALITY ASSURANCE TESTING (see page UU-2)
- Submittal of satisfactory results of required test (such as pressure test, leakage tests, compaction tests, etc.) certified by the Engineer or an approved independent laboratory.
- Submittal of "As-Built" construction drawings electronically shall be in PDF format. All "As-Built" drawings shall be certified by a licensed Professional Engineer and shall state the dates of installation and the name of the Contractor who installed the system. As-Built drawings shall also be submitted as an electronic AutoCAD file in accordance with the Grand Junction *Submittal Standards for Improvements and Developments Manual*.

As-Built drawing shall include the following information: For sewers, horizontal and vertical information on all manholes, catch basins and service stub outs including grades. For water lines, both potable and irrigation, all horizontal and vertical information shall be required on all service lines and fittings. Water line as-builts shall also identify material type as well as the outside diameter of all water lines connected into. For all utilities, horizontal and vertical information is required at all crossings of other utilities.

- Submittal of copies of all inspection reports including the inspector's daily diaries.

4. City Managed Projects.

- Submittal of satisfactory results of tests (such as pipeline pressure test, leakage tests, etc.) required to be performed by the Contractor.
- Contractor is responsible to submit as-built drawings in accordance with Section 54 of the *General Contract Conditions* which shall also include the following information: For sewers, horizontal and vertical information on all manholes, catch basins and service stub outs including grades. For water lines, both potable and irrigation, all horizontal and vertical information shall be required on all service lines and fittings. Water line as-builts shall also identify material type as well as the outside diameter of all water lines tied into. For all utilities, horizontal and vertical information is required on all crossings of other utilities. The information shall be neatly printed on blue-line copy of the plan set.

SECTION 108 - MEASUREMENT AND PAYMENT

108.1 Description.

The complete and accepted pipeline will be paid for in accordance with the items listed in the *Bid Schedule*, approved *Change Orders* and these specifications.

The contract unit prices bid for the various pay items in the *Bid Schedule* shall be full compensation for furnishing all materials, labor, equipment, tools, and other incidental items required for completion of the Work in accordance with the *Construction Drawings* and *Contract Documents*.

The quantities shown on the *Bid Schedule* are approximate only. Payment will be based on measurement of actual quantities installed and approved.

108.2 Conduit.

Unless otherwise specified, conduit of the various sizes, types and classes shown on the *Bid Schedule* will be paid for at the contract unit price per linear foot along the centerline of the accepted conduit from end to end. The footage of conduit to be paid for will include the lengths of wyes, fittings, valves, valve vaults and manholes in line with the pipe but will not include the length of storm drain inlet boxes, culvert end sections or other structures in line with or connected to the pipe. Conduits terminating at a valve, hydrant or manhole shall be measured from (or to) the point of intersection with the valve or hydrant or to the center of the manhole.

The contract unit price for each conduit type shall include excavation, bedding, pipe installation, backfill and compaction. When the excavated material from the trench is unsuitable for backfill, as determined or agreed to by the Engineer the unsuitable material shall be hauled away and disposed of by the Contractor and suitable backfill material shall be imported. Imported material may consist of earth, pit-run aggregate or other suitable material conforming to Subsection 103.16. The contract unit price for "Imported Trench Backfill" shall include the full compensation for haul and disposal of unsuitable excavated material.

The contract unit price for water pipe shall include all disinfecting operations, pressure testing, tracing wire for PVC pipe, and tracing wire continuity testing. The contract unit price for water pipe (ductile iron) shall include polyethylene encasement of the pipe. The contract unit price for sewer line shall include pressure testing the pipeline including furnishing water tight plugs.

City of Grand Junction, Colorado
Standard Specifications for the Construction of Underground Utilities

Payment will be made under:

<u>Ref.</u>	<u>Pay Item</u>	<u>Pay Unit</u>
108.2	___" Water Pipe (C-900 PVC)	Linear Foot
108.2	___" Water Pipe (C-905 PVC)	Linear Foot
108.2	___" Water Pipe (Ductile Iron)	Linear Foot
108.2	___" Water Pipe (_____)	Linear Foot
108.2	___" Gravity Sewer Pipe (SDR 35 PVC)	Linear Foot
108.2	___" Gravity Sewer Pipe (_____)	Linear Foot
108.2	___" Sewer Service Pipe (SDR 35 PVC)	Linear Foot
108.2	___" Pressure Sewer Pipe (D-2241 PVC)	Linear Foot
108.2	___" Pressure Sewer Pipe (C-900 PVC)	Linear Foot
108.2	___" Storm Drain Pipe (_____)	Linear Foot
108.2	___" Storm Drain Pipe(_____ (flow-fill backfill)	Linear Foot
108.2	___" Culvert (_____)	Linear Foot
108.2	___" Culvert (_____) (flow-fill backfill)	Linear Foot
108.2	___" Culvert End Section (_____)	Each
108.2	___" Irrigation Pipe (_____)	Linear Foot
108.2	___" Under-drain Pipe (_____)	Linear Foot
108.2	Imported Trench Backfill (including haul and disposal of unsuitable excavated material) Ton, Cu. Yd.	

108.3 Sewer Taps, Water Valves, Fittings and Hydrants.

Valves, fittings and fire hydrants for water lines and irrigation systems will be paid for at the contract unit price per "each" for the different sizes, types and classes listed in the *Bid Schedule*. Fittings that are shown on the plans or specified in the *Contract Documents* but not listed in the *Bid Schedule*, shall be considered incidental to the Work and will not be paid for separately. The number of valves, fittings and hydrants to be paid for will be the number of units furnished, installed and approved.

The contract unit prices for water line valves, fittings and fire hydrants shall include mechanical restraints, bedding, backfill, compaction and polyethylene encasement of all buried valves, fittings and hydrants. The contract unit price for valves shall include the valve box, valve box lid and adjustment of the valve box to final grade.

The contract unit price for ___" x ___" Sewer Service Tap shall include a full body wye, Inserta-Tee or saddle (in accordance with Section 104.2b), cleanout and all fittings required to align and connect the sewer service pipe to the sewer tap. Sewer service pipe will be measured and paid for separately under Gravity Sewer Pipe.

Payment will be made under:

City of Grand Junction, Colorado
Standard Specifications for the Construction of Underground Utilities

<u>Ref.</u>	<u>Pay Item</u>	<u>Pay Unit</u>
108.3	___" Gate Valve	Each
108.3	___" Butterfly Valve	Each
108.3	___" Air Valve and Vault	Each
108.3	___" _____ Valve	Each
108.3	___" x ___" Tapping Sleeve and Valve	Each
108.3	___" x ___" Tee	Each
108.3	___" x ___" Cross	Each
108.3	___", ___° Elbow	Each
108.3	___" End Cap / Plug	Each
108.3	___" x ___" Reducer	Each
108.3	___" Fitting (Special) (_____)	Each
108.3	Fire Hydrant	Each
108.3	___" x ___" Sewer Service Tap	Each

108.4 Water Service Lines.

Water service lines will be paid for at the contract unit price per linear foot for each size of line installed and approved. This price shall include the cost of furnishing and installing service pipe, all necessary fittings, and connections. The tap, corporation stop, curb stop, meter setter and meter pit will be paid for" per each unit installed and approved. The water service line components may be grouped under a single line item, "Water Service Assembly" in the *Bid Schedule*. A "Water Service Assembly" shall consist of the tap, tapping saddle, corporation stop, curb stop, meter setter and meter pit.

Payment will be made under:

<u>Ref.</u>	<u>Pay Item</u>	<u>Pay Unit</u>
108.4	___ Water Service Line (Type K Copper)	Linear Foot
108.4	___" Water Service Line (D-1785 PVC)	Linear Foot
108.4	___" x ___" Tapping Saddle	Each
108.4	___" Corporation Stop	Each
108.4	___" Corporation Stop (Install Only)	Each
108.4	___" Curb Stop	Each
108.4	___"Curb Stop (Install Only)	Each
108.4	___" Meter Setter	Each
108.4	___" Meter Setter (Install Only)	Each
108.4	___" Water Service Assembly	Each
108.4	___" Water Service Assembly (Install Only)	Each
108.4	Meter Pit	Each
108.4	Meter Pit (Install Only)	Each

108.5 Manholes.

Manholes up to 5 feet deep, and the first 5 feet of manholes greater than 5 feet deep, will be paid for at the contract unit price for Sanitary Sewer Basic Manhole (___" I.D.), Storm Sewer Basic Manhole (___" I.D.) or Irrigation Basic Manhole (___" I.D.). These items will include payment for the complete base, pipe connections, eccentric cone, barrel section (if required), grade rings, ring and cover and adjustment to final grade. For manholes greater than 5 feet deep, the additional length of manhole barrel section required will be paid for at the contract unit price per linear foot for Manhole Barrel Section (___" I.D.). The pay length for the manhole barrel sections will be the height (D) from the lowest invert or bottom of sump to the top of the manhole ring and cover minus 5.0 feet. Drop Manholes will be paid for under a combination of two items: The contract unit price per "each" for "Sanitary Sewer Basic Drop Manhole" shall include the base, pipe connections, eccentric cone, barrel section (if required), drop pipe and fittings, grade rings, ring and cover and adjustment to final grade, per Standard Detail SS-04. For drop manholes greater than 5 feet deep, additional manhole barrel sections will be paid for at the contract unit price per linear foot for "Drop Manhole Barrel Section (___" I.D.)". The pay length for drop manhole barrel sections will be the height (D) from the lowest invert to the top of the manhole ring and cover minus 5.0 feet

Drop manholes shall be epoxy coated or plastic lined in accordance with Section 102.11.

The unit price for "Connect to Existing Manhole (___" pipe)" shall include removal and reconstruction of the concrete bench and invert in the base of the manhole where required.

Payment will be made under:

<u>Ref.</u>	<u>Pay Item</u>	<u>Pay Unit</u>
108.5	Sanitary Sewer Basic Manhole (___" I.D.)	Each
108.5	Sanitary Sewer Basic Drop Manhole (___" I.D.)	Each
108.5	Storm Sewer Basic Manhole (___" I.D.)	Each
108.5	Manhole Barrel Section (D>5') (___" I.D.)	Lin. Ft.
108.5	Drop Manhole Barrel Section (D>5') (___" I.D.)	Lin. Ft.
108.5	Connect to Existing Manhole (___" pipe)	Each
108.5	Convert Existing Manhole to Drop Manhole (___" I.D.)	Each
108.5	Irrigation Basic Manhole (___" I.D.)	Each

108.6 Storm Drain Inlets.

Storm drain inlets will be paid for at the contract unit price "each" for the various sizes, types listed in the *Bid Schedule*. The number of inlets to be paid for will be the number of complete units, including inlet box, grate and frame constructed and approved. For inlets where the height (D) from the floor of the box to the flowline of the grate is greater than 5 feet the additional box height will be paid for at the contract unit price per linear foot for "Inlet Box Riser Section (D>5)".

City of Grand Junction, Colorado
Standard Specifications for the Construction of Underground Utilities

Payment will be made under:

<u>Ref.</u>	<u>Pay Item</u>	<u>Pay Unit</u>
108.6	Single Storm Drain Inlet (Vertical Curb)	Each
108.6	Single Storm Drain Inlet (Drive Over Curb)	Each
108.6	Double Storm Drain Inlet (Vertical Curb)	Each
108.6	Double Storm Drain Inlet (Drive Over Curb)	Each
108.6	Triple Storm Drain Inlet (Vertical Curb)	Each
108.6	Triple Storm Drain Inlet (Drive Over Curb)	Each
108.6	Small Area Inlet	Each
108.6	Small Area Inlet with Concrete Collar	Each
108.6	Large Area Inlet	Each
108.6	Large Area Inlet with Concrete Collar	Each
108.6	Inlet Box Riser Section (>5')	Linear Foot

108.7 Granular Stabilization Material.

When the use of granular stabilization material is ordered or authorized by the Engineer, it will be paid for at the contract unit price per ton of material placed and approved. The tonnage of material to be paid for will be determined from weight tickets collected at the time of delivery to the job site. Over-excavation and the disposal of the over-excavated material will not be measured and paid for separately but shall be considered incidental to this item.

For each load of granular stabilization material delivered, a weight ticket shall be given to the Engineer's field representative by the driver of the truck. Each ticket shall have the following information:

Date _____
 Truck _____
 Total Weight _____
 Tare Weight _____
 Weight of material delivered _____
 Truck driver's signature _____

Payment will be made under:

<u>Ref.</u>	<u>Pay Item</u>	<u>Pay Unit</u>
108.7	Granular stabilization Material (Type B)	Ton

108.8 Rock Excavation.

No payment will be made for "rock excavation" unless the method and costs of such work are established and approved by the Engineer in writing before any rock excavation is done.

108.9 Pavement Replacement.

All plant mix pavement, paving and patching operations shall be in accordance with Section 401 of the City's Standard Specifications for Road and Bridge Construction.

Unless otherwise specified or approved, the area of pavement replacement to be paid for shall be the same as that designated for removal.

Where pavement is removed beyond the limits designated on the *Construction Drawings* or otherwise approved, the Contractor shall replace the pavement at his own expense. The contract unit prices for "Hot Bituminous Pavement" shall be full compensation for replacement of the hot bituminous pavement and aggregate base course material to the thickness shown on the plans of specified in the pay items listed below.

Basis of Payment:

Hot Bituminous Pavement will be paid for in accordance with Section 401.08 of the City's Standard Specifications for Road and Bridge Construction.

In cases where the depth and width of the trench could be contingent upon the methods and equipment available to a contractor (such as shoring), the City reserves the right to bid pavement replacement on a linear foot of trench basis in order to allow the Contractor a wider range of methodologies.

108.10 Erosion Control.

The furnishing, installation and maintenance and removal of erosion control measures will be measured and paid for in accordance with Subsection 208.07 and 208.08 of the CDOT Standard Specifications for Road and Bridge Construction as amended by the City's Standard Specifications for Road and Bridge Construction, unless otherwise specified in the Contract Documents.

108.11 Traffic Control

Construction zone traffic control will be measured and paid for in accordance with Subsections 630.14 and 630.15 of the City's Standard Specifications for Road and Bridge Construction, unless otherwise specified in the Contract Documents .

108.12 Dust Control

Dust control including the furnishing and placement of water or other approved palliative will be measured and paid for in accordance with Subsections 209.07 and 209.08 of the City's Standard Specifications for Road and Bridge Construction, unless otherwise specified in the Contract Documents.

108.13 Incidental Construction.

The following list of materials and items of work may be required to complete the work but may or may not be shown on the plans or described in the Contract Documents. Unless otherwise specified or provided for in the *Bid Schedule*, these items will be considered incidental to the work and will not be measured or paid for separately. All costs for the following incidental items shall be included in the contract prices for the various pay items listed in the *Bid Schedule*.

1. All surface removals including removal of asphalt pavement, concrete, fences, plantings, and structures.
2. The location and protection of existing utilities.
3. All excavation except rock excavation (See section 103.11 for payment for rock excavation.)
4. The support bracing and sheeting of trenches.
5. All equipment, materials and labor required for dewatering of trenches. This work shall include applying for and obtaining required permits from the CDPHE prior to discharging any groundwater.
6. The furnishing and placement of all granular pipe bedding, haunch and initial backfill material; structure bed course and backfill materials; stockpiling, handling and placement of all native backfill materials generated from project excavations.
7. The furnishing of water, adjusting backfill materials to the required moisture content and compaction of all backfill materials to the required densities.
8. The furnishing and placement of cutoff walls on all pipelines in accordance with Subsection 103.10.
9. The clean up and restoration of grounds.
10. The removal and disposal of all waste materials including excess excavated material, trash and debris resulting from the Work.
11. The furnishing and installation of tracing wire.
12. The furnishing and installation of polyethylene encasement material for all metal pipe, valves, fittings, and other metal surfaces (except aluminum or aluminized steel drainage pipe and culverts) .
13. The furnishing and installation of thrust restraints, whether mechanical or concrete support and thrust blocking, required on pressure pipelines.
14. All pressure and leakage testing.
15. The flushing and disinfection of waterlines.
16. The connection of new pipeline to existing structures or pipes.

City of Grand Junction, Colorado
Standard Specifications for the Construction of Underground Utilities

17. The separation, removal and disposal of muck, large rock, organic matter or other materials from project excavations, which in the opinion of the Engineer are unsuitable for use in the backfill. No separate or additional payment will be made for hauling and disposing of unsuitable materials.
18. Concrete encasement of sewer line connections and sewer service line connections.

END SPECIFICATIONS



**PUBLIC WORKS
& PLANNING**

STANDARD DETAILS

FOR CONSTRUCTION OF
STREETS, STORM DRAINS AND UTILITIES

REVISED JUNE 2010

STANDARD CONCRETE DETAILS	_____	C-00 TO C-35
STANDARD STORM DRAIN DETAILS	_____	D-00 TO D-15
GENERAL UTILITY DETAILS	_____	GU-00 TO GU-12
STANDARD SANITARY SEWER DETAILS	_____	SS-00 TO SS-10
STANDARD WATERLINE DETAILS	_____	W-00 TO W-18

- C-01 General Notes
- C-02 Monolithic Vertical Curb, Gutter and Sidewalk
- C-03 Drive Over Curb, Gutter and Sidewalk (Residential Streets Only)
- C-04 Drive Over Curb and Gutter (Residential Streets Only)
- C-05 Vertical Curb and Gutter
- C-06 Joint Details for Curb, Gutter, Sidewalk and Driveway Approaches
- C-07 Driveway – Detached Sidewalk
- C-08 Driveway – Monolithic Curb, Gutter and Sidewalk
- C-09 Alternate Driveway For Vertical Curb, Gutter and Sidewalk
- C-10 Driveway Section A (Detached Sidewalk) and
Section B (Curb, Gutter and Detached Sidewalk)
- C-11 Driveway Sections C and D (Monolithic Curb, Gutter and Sidewalk)
- C-12 V-pan Detail and Joint Reinforcement
- C-13 Perpendicular Curb Ramp at Intersection
- C-14 General Notes – Applies to All Curb Return Joint Sheets
- C-15 Curb Return Joints – 15' Radius Face of Curb
- C-16 Curb Return Joints – 20' Radius Face of Curb
- C-17 Curb Return Joints – 25' Radius Face of Curb
- C-18 Curb Return Joints – 30' Radius Face of Curb
- C-19 Curb Return Joints – 35' Radius Face of Curb
- C-20 Perpendicular Curb Ramp and Sections G and H
- C-21 Alternate Ramp Without Landing
- C-22 Curb Ramp (Front View)
- C-23 Detectable Warning For Curb Ramp
- C-24 Standard Accessible Parking Stall
- C-25 Sidewalk Retrofit Detail
- C-26 Radii and Right-of-way Width at Intersection Corner
- C-27 Asphalt Patch Adjacent To Curb And Gutter
- C-28 Joint Seal For Concrete Pavement
- C-29 Joint Details For Concrete Pavement
- C-30 Longitudinal Joints For Concrete Pavement
- C-31 Mail Box Installation
- C-32 Patch In Concrete Pavement
- C-33 Minimum Access Spacing and Corner Clearance
- C-34 Driveway Approach Grades
- C-35 Median Curb Details

TABLE OF CONTENTS – STANDARD CONCRETE DETAILS

DEPARTMENT OF PUBLIC WORKS AND PLANNING ENGINEERING DIVISION CITY OF GRAND JUNCTION, COLORADO	STANDARD CONCRETE DETAILS	APPROVED: <u>DN</u> REVISED: <u>FEB. 2007</u> DRAWN: <u>TLT</u>	PAGE C-00
---	------------------------------	---	--------------

1. ALL PORTLAND CEMENT CONCRETE SHALL BE COLORADO DEPARTMENT OF TRANSPORTATION CLASS "B". ALL CONCRETE SHALL BE MIXED, PLACED, CURED AND TESTED IN ACCORDANCE WITH CITY OF GRAND JUNCTION STANDARD SPECIFICATIONS FOR ROAD AND BRIDGE CONSTRUCTION.
2. ALL CONCRETE WORK WITHIN PUBLIC RIGHT-OF-WAY SHALL BE PERFORMED BY A CITY LICENSED CONTRACTOR. A CONSTRUCTION PERMIT IS REQUIRED AT EACH LOCATION WHERE CONCRETE IS REMOVED, ALTERED OR PLACED.
3. ALL CURBS, GUTTERS, SIDEWALKS, DRIVEWAYS, CURB RAMPS, FILLETS AND DRAINAGE PANS SHALL BE UNDERLAID WITH AGGREGATE BASE COURSE (CLASS 6) COMPACTED TO NO LESS THAN 95% PER AASHTO T-180. SEE DETAILS FOR BASE COURSE THICKNESS AND SUBGRADE RECONDITIONING REQUIREMENTS. SUBGRADE RECONDITIONING WILL NOT BE REQUIRED FOR REPLACEMENT OR CONSTRUCTION OF CURBS, GUTTERS, SIDEWALKS, DRIVEWAYS CURB RAMPS, FILLETS, AND DRAINAGE PANS ON EXISTING STREETS. THE TOP 6" OF SUBGRADE SHALL BE COMPACTED TO NO LESS THAN 95% PER AASHTO T99 UNLESS OTHERWISE SPECIFIED OR APPROVED BY THE ENGINEER.
4. ALL EXISTING PAVEMENT, NOT DESIGNATED FOR REMOVAL, THAT IS DAMAGED BY CONSTRUCTION SHALL BE REPLACED IN-KIND BY CONTRACTOR.
5. ALL DRIVEWAY CONCRETE (APRON AND SIDEWALK CROSSING) SHALL BE 6 INCHES THICK (MIN.) FOR RESIDENTIAL USES AND 8" THICK (MIN.) FOR ALL OTHER USES.
6. TRANSVERSE EXPANSION JOINTS SHALL BE PROVIDED IN ALL CONCRETE CURBS, GUTTERS, SIDEWALKS AND TRAILS, ETC., AT ENDS OF HORIZONTAL CURVES AND AT SPACING SHOWN ON PAGE C-06. TRANSVERSE CONTRACTION JOINTS SHALL BE PROVIDED AT 10' SPACING.
7. VEHICULAR TRAFFIC SHALL BE KEPT OFF NEW CONCRETE FOR A MINIMUM OF 14 DAYS OR UNTIL THE CONCRETE REACHES A COMPRESSIVE STRENGTH OF EQUAL TO OR GREATER THAN 80% OF DESIGN.
8. WHEN DURING CONCRETE FINISHING OPERATIONS THE RATE OF EVAPORATION APPROACHES 0.2 LB/SQ.FT/HR AN EVAPORATION REDUCER SUCH AS CONFILM MANUFACTURED BY MASTER BUILDERS IS RECOMMENDED AND MAY BE REQUIRED TO CONTROL PLASTIC SHRINKAGE CRACKS IN THE CONCRETE SURFACE.
9. AN APPROVED CURING COMPOUND SHALL BE APPLIED TO ALL EXPOSED CONCRETE IMMEDIATELY AFTER FINISHING. FOR APPROVED COMPOUNDS SEE SECTION 711 OF THE STANDARD SPECIFICATIONS FOR ROAD AND BRIDGE CONSTRUCTION.
10. WHEN AMBIENT TEMPERATURE IS EXPECTED TO BE BELOW 40°F THE APPLICATION OF CURING COMPOUND SHALL BE STOPPED AND INSULATION BLANKETS OR OTHER APPROVED CURING METHODS SHALL BE USED. CURING METHODS THAT CAUSE OVERHEATING OR DRYING OF THE CONCRETE SHALL NOT BE USED. NO CONCRETE SHALL BE PLACED ON FROZEN GROUND.
11. UNDER NO CIRCUMSTANCES SHALL WATER BE ADDED TO CONCRETE SURFACES DURING FINISHING OPERATIONS.
12. HANDICAP RAMPS SHALL BE INSTALLED IN EACH CORNER OF ALL NEW STREET INTERSECTIONS. SEE PAGES C-13 THROUGH C-24 FOR DETAILS.
13. "CONTROL JOINT" SHALL HAVE THE SAME MEANING AS "CONTRACTION JOINT".
14. SEE PAGE C-32 FOR CONCRETE PAVEMENT PATCHING DETAIL.

GENERAL NOTES

DEPARTMENT OF PUBLIC WORKS AND PLANNING
ENGINEERING DIVISION
CITY OF GRAND JUNCTION, COLORADO

STANDARD CONCRETE
DETAIL

APPROVED: SBG
REV: JULY 2010
DRAWN: JAH

PAGE
C-01

SEE PROJECT PLANS FOR
PAVEMENT AND BASE COURSE
TYPE AND THICKNESSES

FINISH BITUMINOUS PAVEMENT 1/2"
TO 1" ABOVE EDGE OF GUTTER

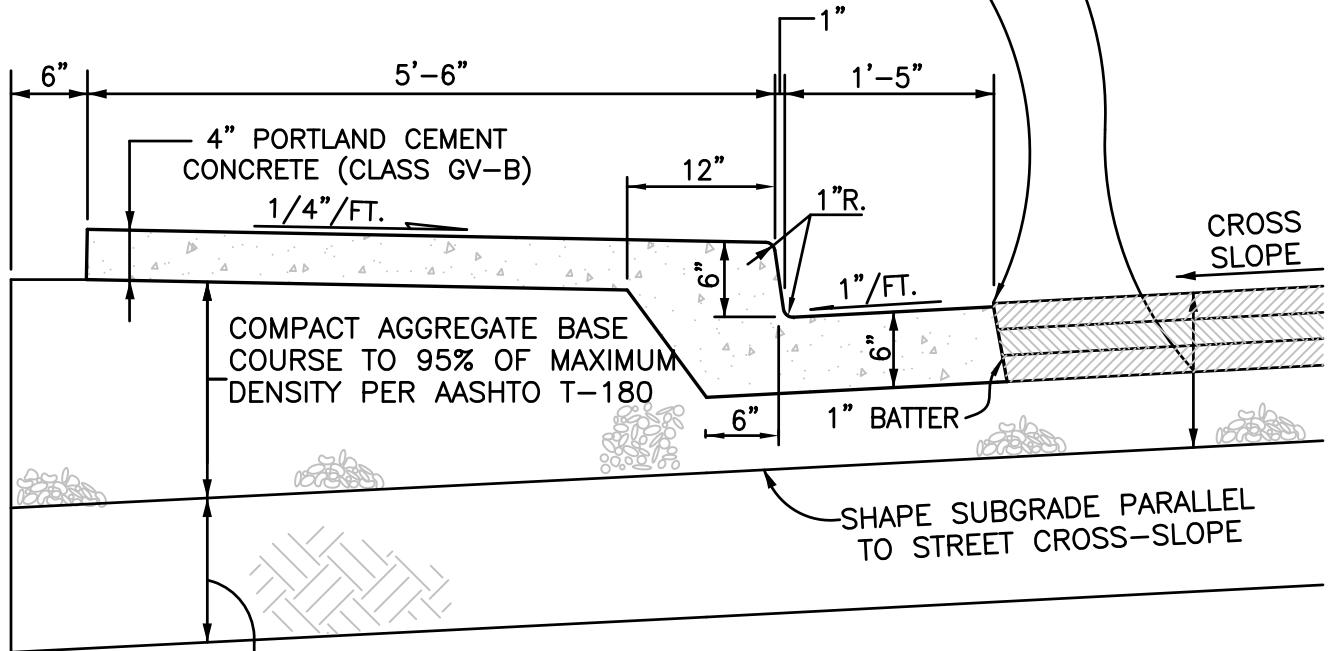

12" MIN. SUBGRADE RECONDITIONING - SHALL
INCLUDE REMOVAL, REPLACEMENT AND COMPACT
SOIL TO 95% OF MAXIMUM DENSITY PER AASHTO
T-99 OR PER SUB-SECTION 203.07 OF THE
CDOT STANDARD SPECIFICATIONS.

STANDARD FOR MINOR ARTERIAL, COMMERCIAL
AND COLLECTOR STREET CLASSIFICATIONS.

SEE DETAILS ON PAGE C-25 FOR
CONSTRUCTION OF SIDEWALK ADJACENT TO
EXISTING CURB AND GUTTER

MONOLITHIC VERTICAL CURB, GUTTER AND SIDEWALK

DEPARTMENT OF PUBLIC WORKS AND PLANNING
ENGINEERING DIVISION
CITY OF GRAND JUNCTION, COLORADO

STANDARD CONCRETE
DETAIL

APPROVED: DN
DATE: JAN. 2009
DRAWN: GM

PAGE
C-02

SEE PROJECT PLANS FOR PAVEMENT AND BASE COURSE TYPE AND THICKNESSES

FINISH BITUMINOUS PAVEMENT 1/2" TO 1" ABOVE EDGE OF GUTTER

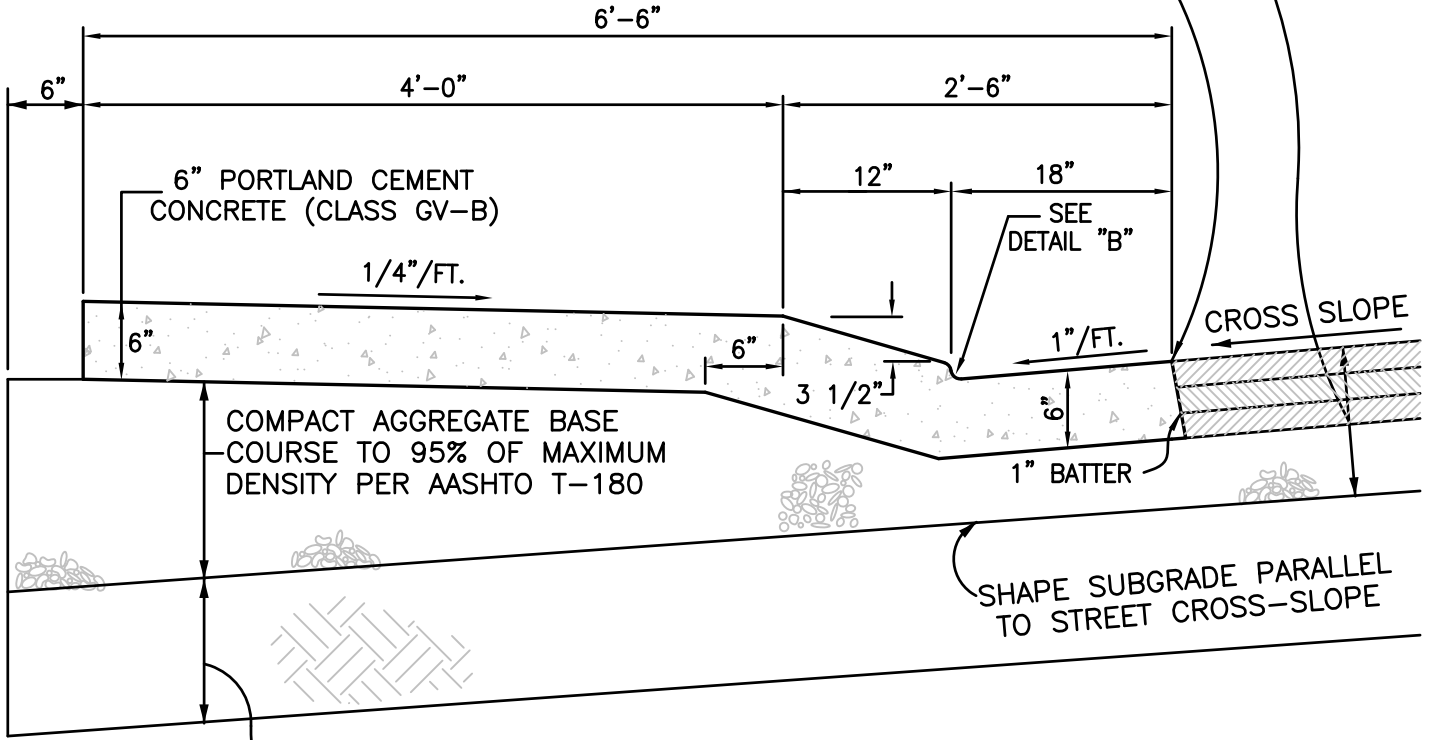

12" MIN. SUBGRADE RECONDITIONING - SHALL INCLUDE REMOVAL, REPLACEMENT AND COMPACT SOIL TO 95% OF MAXIMUM DENSITY PER AASHTO T-99 OR PER SUB-SECTION 203.07 OF THE CDOT STANDARD SPECIFICATIONS.

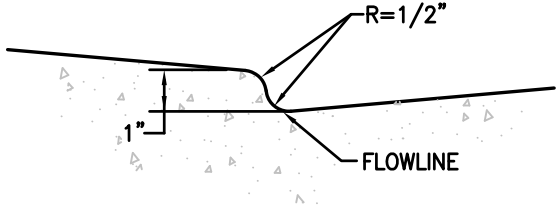

DETAIL "B"

DRIVE OVER CURB, GUTTER AND SIDEWALK (RESIDENTIAL STREETS ONLY)

DEPARTMENT OF PUBLIC WORKS AND PLANNING
ENGINEERING DIVISION
CITY OF GRAND JUNCTION, COLORADO

STANDARD CONCRETE
DETAIL

APPROVED: DN
DATE: FEB. 2006
DRAWN: GM

PAGE
C-03

N:\Cadd\CITY STANDARDS\STANDARD DRAWING DETAILS\2008 October Revisions\2008-10-Concrete Details.dwg, C-03 (REV 1-2009), 3/2/2009 9:31:55 AM

N:\Cadd\CITY STANDARDS\STANDARD DRAWING DETAILS\2008 October Revisions\2008-10-Concrete Details.dwg, C-04 (REV 1-2009), 3/2/2009 9:33:07 AM

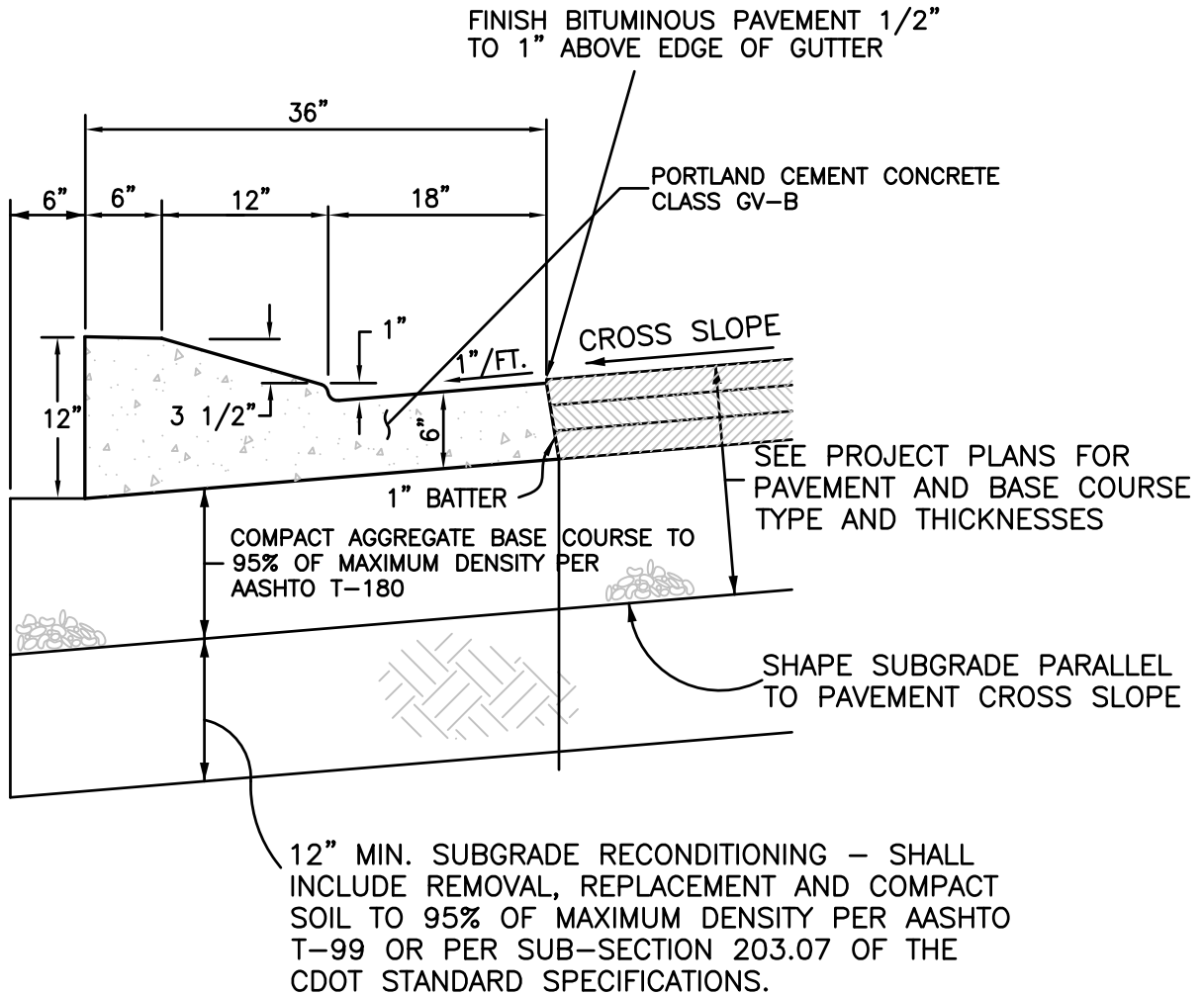

DRIVE OVER CURB AND GUTTER (RESIDENTIAL STREETS ONLY)

DEPARTMENT OF PUBLIC WORKS AND PLANNING
ENGINEERING DIVISION
CITY OF GRAND JUNCTION, COLORADO

STANDARD CONCRETE
DETAIL

APPROVED: DN
REV: JAN. 2009
DRAWN: CM

PAGE
C-04

FINISH BITUMINOUS PAVEMENT 1/2" TO 1" ABOVE EDGE OF GUTTER

* SEE PROJECT PLANS FOR PAVEMENT AND BASE COURSE TYPE AND THICKNESSES

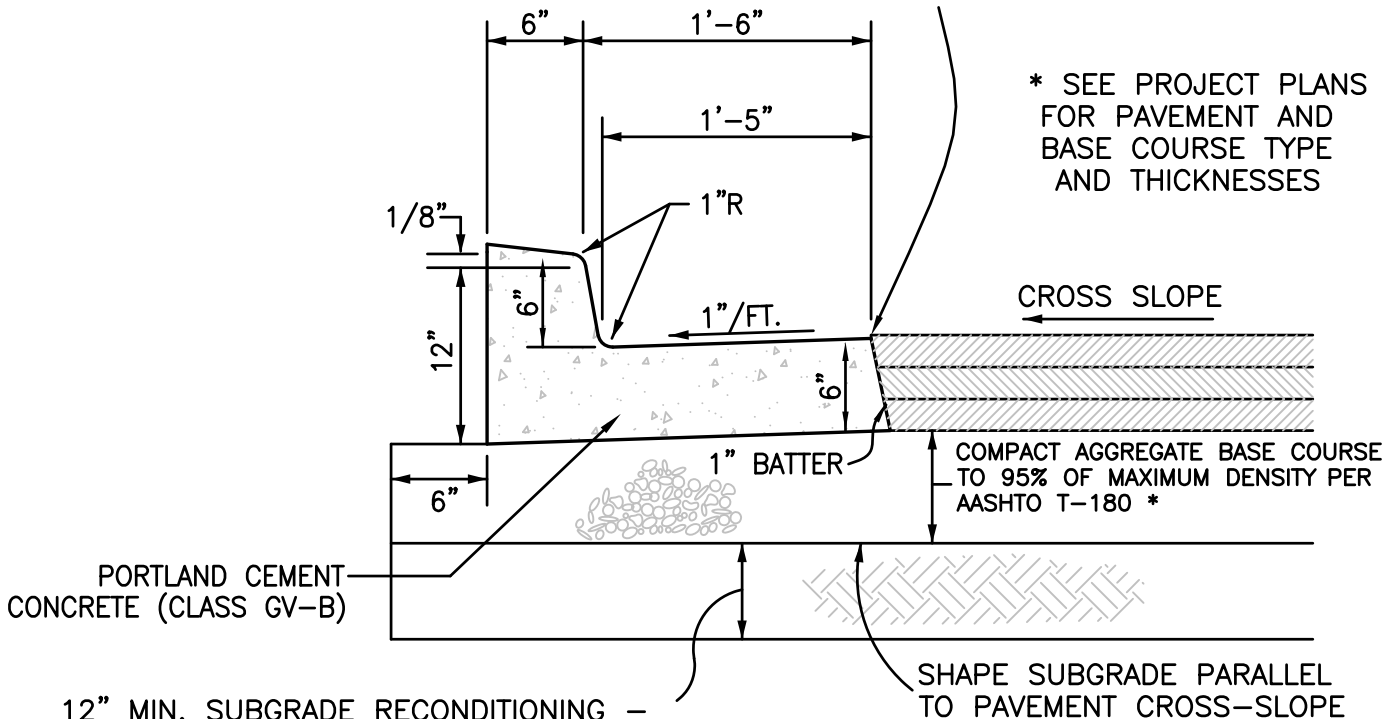

12" MIN. SUBGRADE RECONDITIONING - SHALL INCLUDE REMOVAL, REPLACEMENT AND COMPACT SOIL TO 95% OF MAXIMUM DENSITY PER AASHTO T-99 OR PER SUB-SECTION 203.07 OF THE CDOT STANDARD SPECIFICATIONS.

STANDARD CURB AND GUTTER

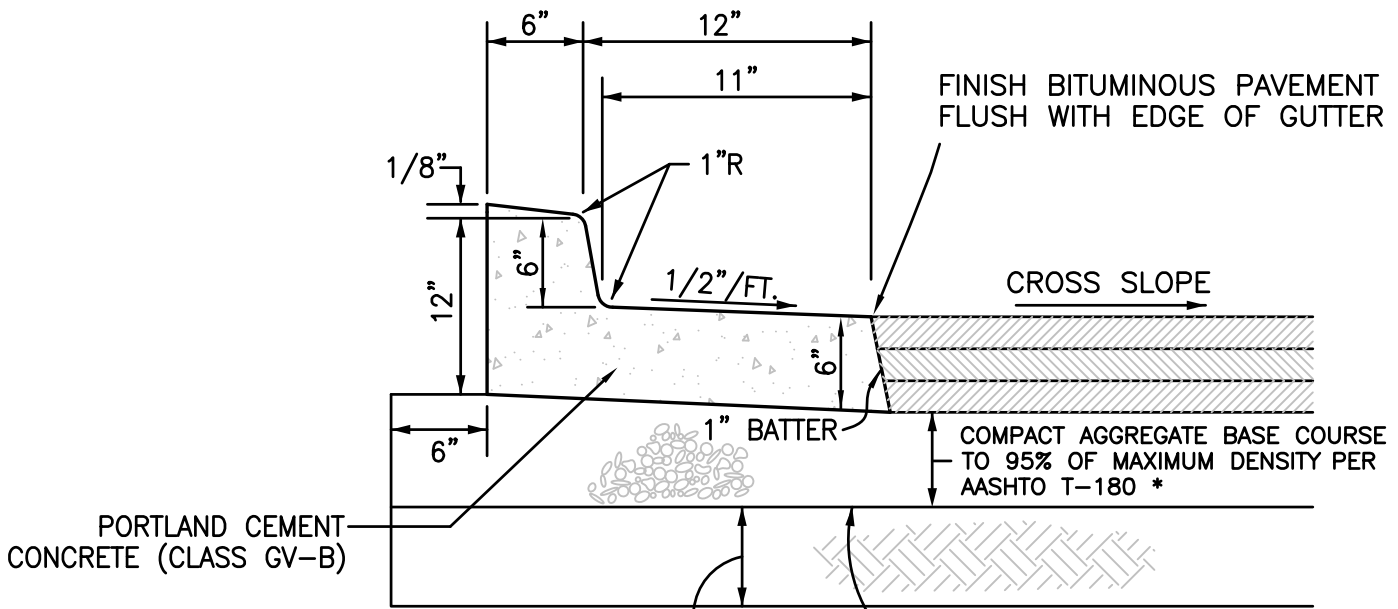

12" MIN. SUBGRADE RECONDITIONING - SHALL INCLUDE REMOVAL, REPLACEMENT AND COMPACT SOIL TO 95% OF MAXIMUM DENSITY PER AASHTO T-99 OR PER SUB-SECTION 203.07 OF THE CDOT STANDARD SPECIFICATIONS.

CURB WITH SPILL GUTTER
(FOR USE ON RAISED MEDIANS ONLY)

VERTICAL CURB AND GUTTER

DEPARTMENT OF PUBLIC WORKS AND PLANNING
ENGINEERING DIVISION
CITY OF GRAND JUNCTION, COLORADO

STANDARD CONCRETE
DETAIL

APPROVED: DN
DATE: JAN 2009
DRAWN: GM

PAGE
C-05

EXPANSION JOINTS SHALL BE PLACED AT THE ENDS OF CURB RADII AND AT INTERVALS OF NOT MORE THAN 500'.

W = 3/4" FOR EXPANSION JOINTS
1/2" FOR ISOLATION JOINTS

SEE SECTION 705.01 OF THE STANDARD SPECS. FOR ROAD AND BRIDGE CONSTRUCTION FOR APPROVED JOINT SEALANTS. SEALANT COLOR SHALL MATCH CONCRETE

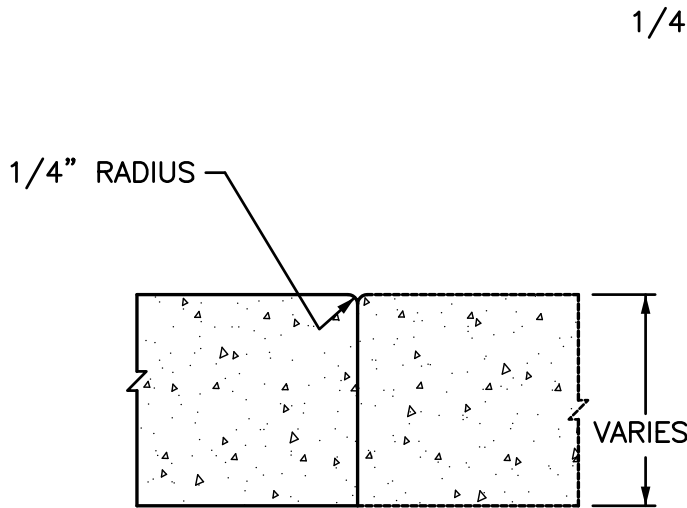

UNDOWELED CONSTRUCTION OR BUTT JOINT

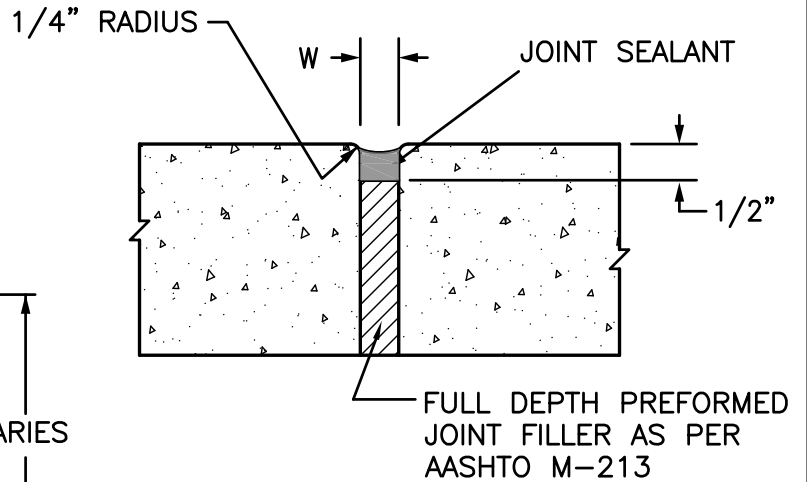

UNDOWELED EXPANSION OR ISOLATION JOINT

CONTRACTION JOINT SPACING

5' MINIMUM
10' STANDARD
10' MAXIMUM

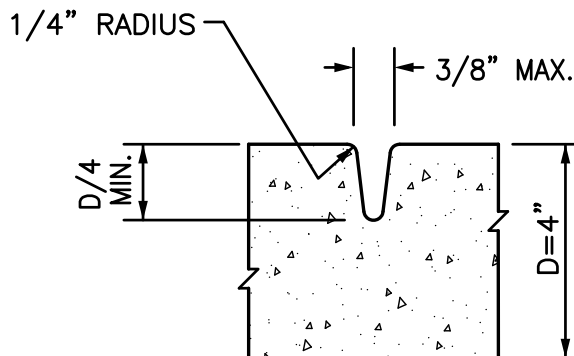

TOOLED JOINT

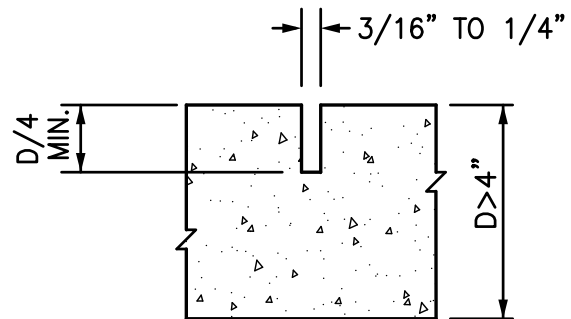

SAWED JOINT

TRANSVERSE CONTRACTION JOINTS

JOINT DETAILS FOR CURB, GUTTER, SIDEWALK AND DRIVEWAY APPROACHES

DEPARTMENT OF PUBLIC WORKS AND PLANNING
ENGINEERING DIVISION
CITY OF GRAND JUNCTION, COLORADO

STANDARD CONCRETE
DETAIL

APPROVED: DN
REV: JUNE 2007
DRAWN: JAH

PAGE
C-06

N:\Cadd\CITY STANDARDS\STANDARD DRAWING DETAILS\2008 October Revisions\2008-10-Concrete Details.dwg, C-06, 3/2/2009 9:53:50 AM

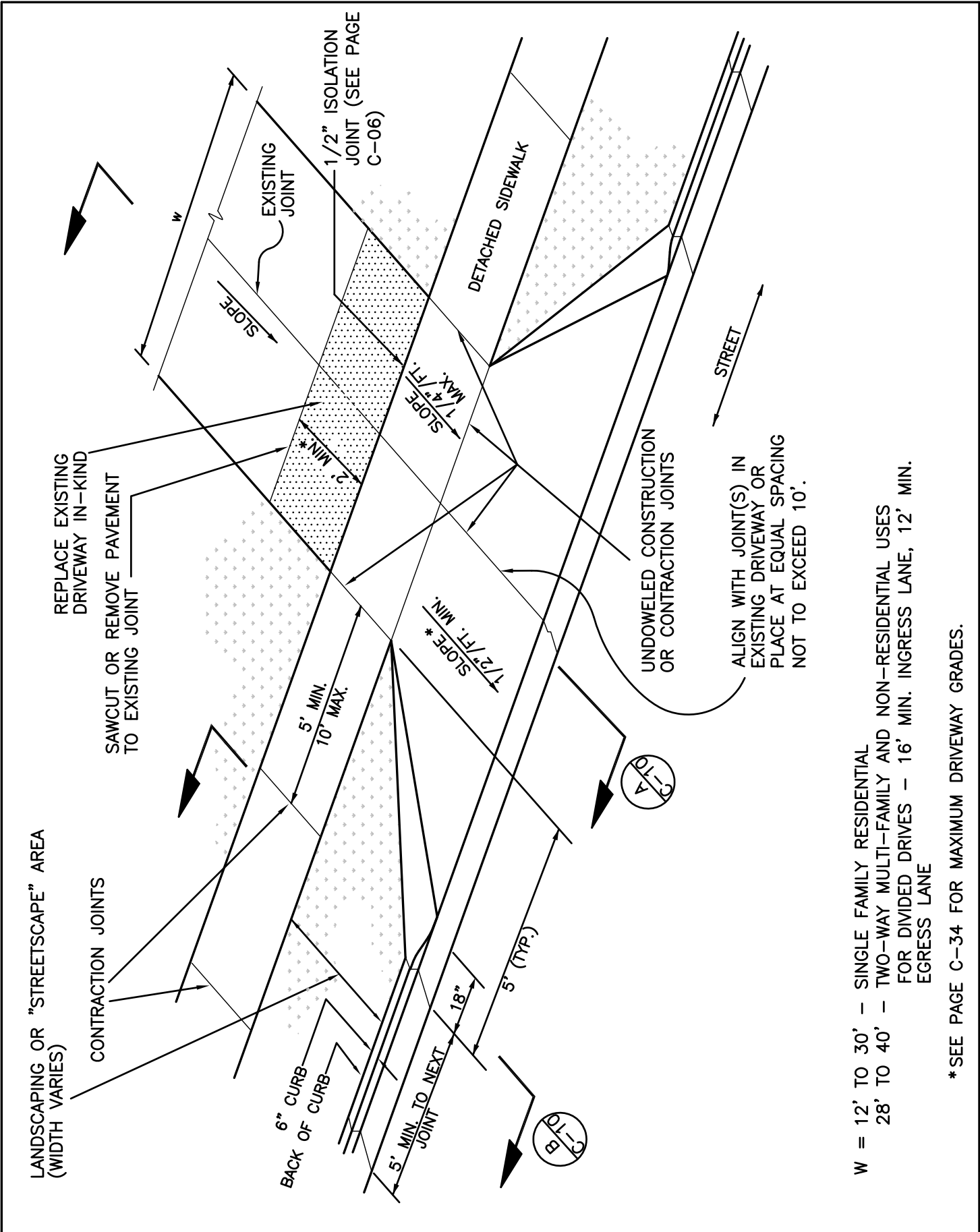

W = 12' TO 30' - SINGLE FAMILY RESIDENTIAL
 28' TO 40' - TWO-WAY MULTI-FAMILY AND NON-RESIDENTIAL USES
 FOR DIVIDED DRIVES - 16' MIN. INGRESS LANE, 12' MIN. EGRESS LANE

* SEE PAGE C-34 FOR MAXIMUM DRIVEWAY GRADES.

DRIVEWAY - DETACHED SIDEWALK

DEPARTMENT OF PUBLIC WORKS AND PLANNING ENGINEERING DIVISION CITY OF GRAND JUNCTION, COLORADO	STANDARD CONCRETE DETAIL	APPROVED: <u>DN</u> REV: <u>JULY 2005</u> DRAWN: <u>GM</u>	PAGE C-07
---	-----------------------------	--	--------------

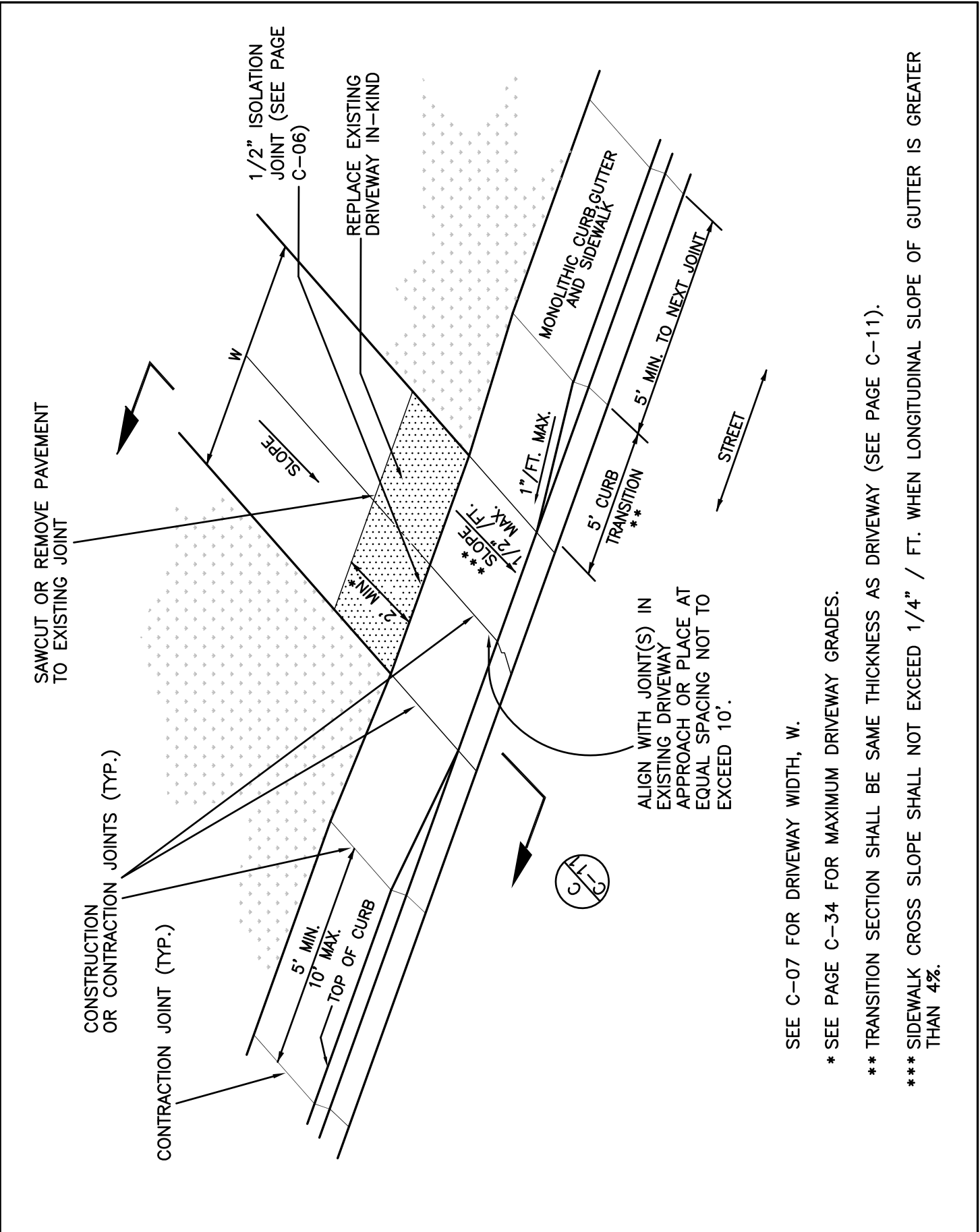

DRIVEWAY - MONOLITHIC CURB, GUTTER AND SIDEWALK

DEPARTMENT OF PUBLIC WORKS AND PLANNING
ENGINEERING DIVISION
CITY OF GRAND JUNCTION, COLORADO

STANDARD CONCRETE
DETAIL

APPROVED: DN
REV: JULY 2005
DRAWN: GM

PAGE
C-08

SEE C-07 FOR DRIVEWAY WIDTH, W.

* SEE PAGE C-34 FOR MAXIMUM DRIVEWAY GRADES.

** TRANSITION SECTION SHALL BE SAME THICKNESS AS DRIVEWAY (SEE PAGE C-11).

*** SIDEWALK CROSS SLOPE SHALL NOT EXCEED 1/4" / FT. WHEN LONGITUDINAL SLOPE OF GUTTER IS GREATER THAN 4%.

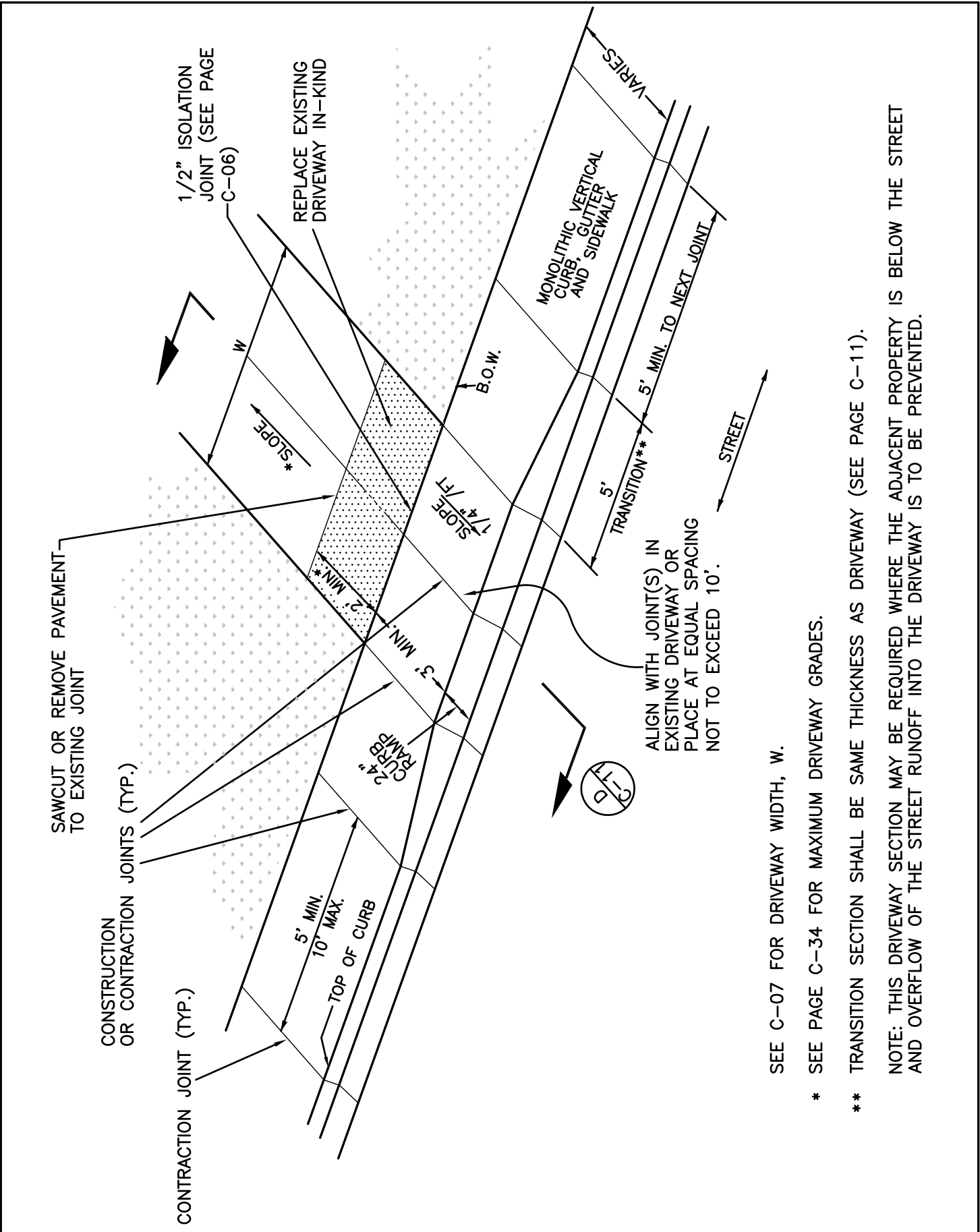

ALTERNATE DRIVEWAY FOR VERTICAL CURB, GUTTER AND SIDEWALK

DEPARTMENT OF PUBLIC WORKS AND PLANNING
ENGINEERING DIVISION
CITY OF GRAND JUNCTION, COLORADO

STANDARD CONCRETE
DETAIL

APPROVED: DN
REV: FEB. 2005
DRAWN: DPW

PAGE
C-09

SEE C-07 FOR DRIVEWAY WIDTH, W.

* SEE PAGE C-34 FOR MAXIMUM DRIVEWAY GRADES.

** TRANSITION SECTION SHALL BE SAME THICKNESS AS DRIVEWAY (SEE PAGE C-11).

NOTE: THIS DRIVEWAY SECTION MAY BE REQUIRED WHERE THE ADJACENT PROPERTY IS BELOW THE STREET AND OVERFLOW OF THE STREET RUNOFF INTO THE DRIVEWAY IS TO BE PREVENTED.

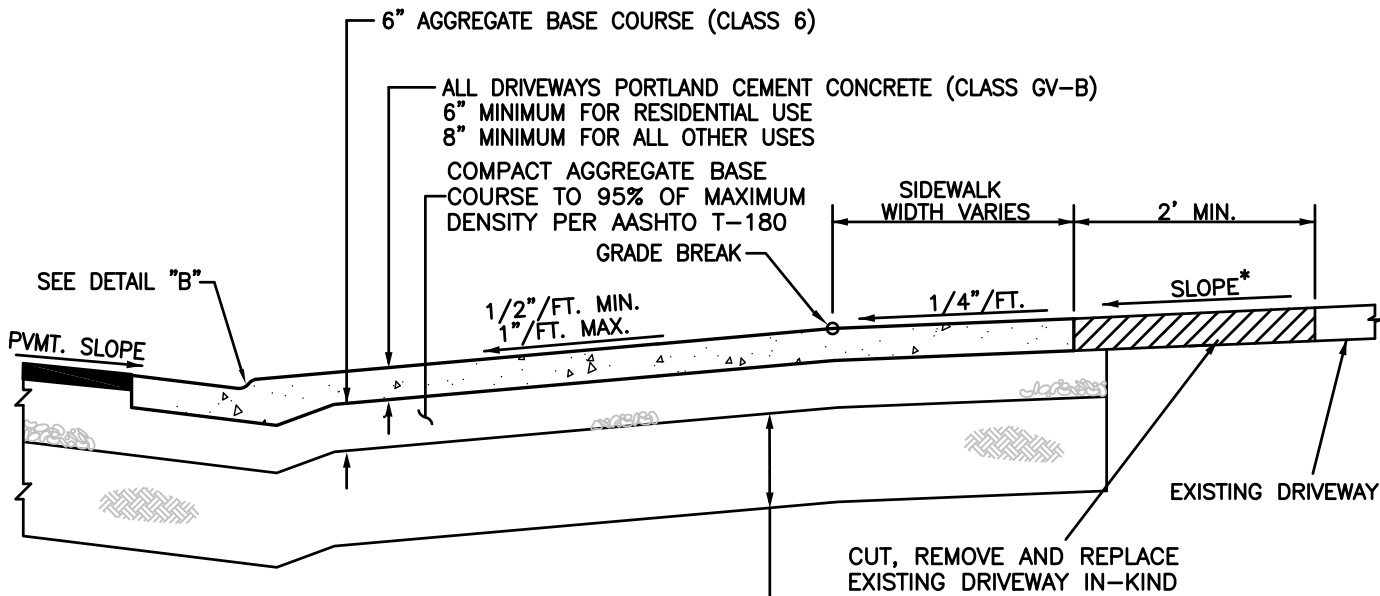

SECTION A
C-07

NOTE: CONCRETE AND AGGREGATE THICKNESS SHOWN ALSO APPLY TO MONOLITHIC C.G. & SW.

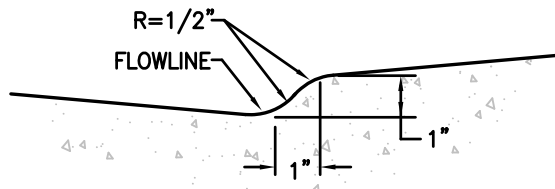

DETAIL "B"

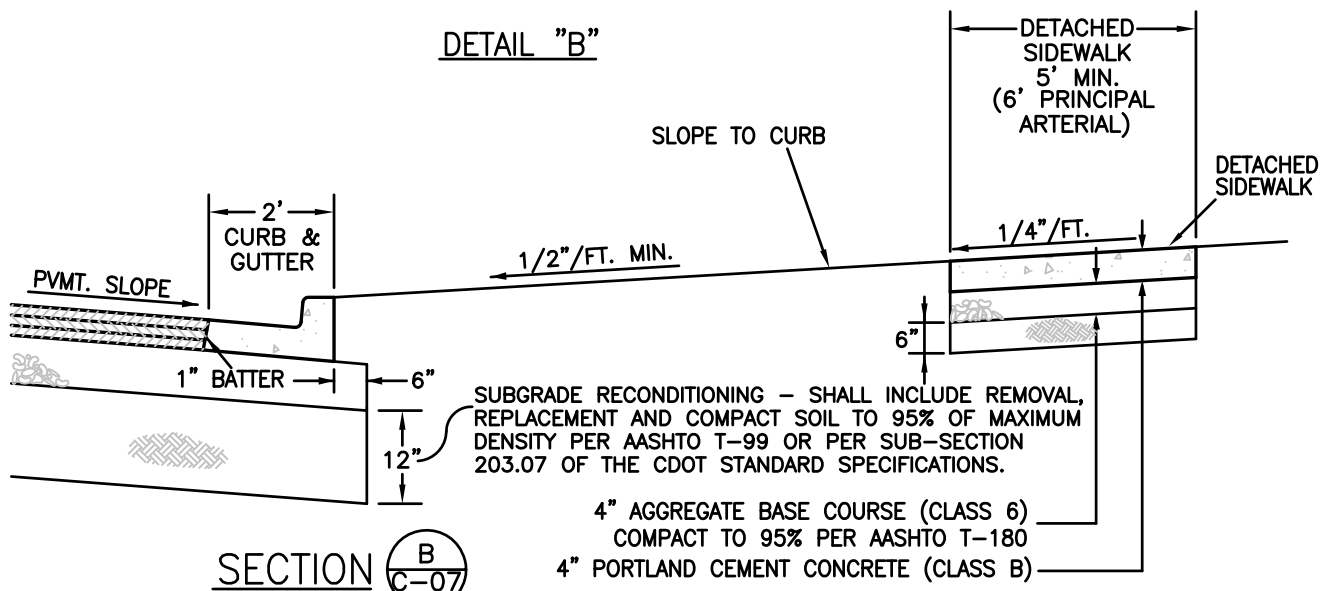

SECTION B
C-07

SIDEWALK MAY BE BELOW CURB ELEVATION AND/OR SLOPE AWAY FROM CURB WHERE APPROVED BY THE CITY ENGINEER.

DRIVEWAY SECTION A (DETACHED SW.) AND DRIVEWAY SECTION B (CURB, GUTTER AND DETACHED SW.)

* SEE PAGE C-34 FOR MAXIMUM SLOPE.

** CROSS SLOPE SHALL NOT EXCEED 1/4" /FT. WHEN LONGITUDINAL SLOPE OF GUTTER IS GREATER THAN 4%.

SEE PROJECT PLANS FOR PAVEMENT AND BASE COURSE TYPE AND THICKNESSES

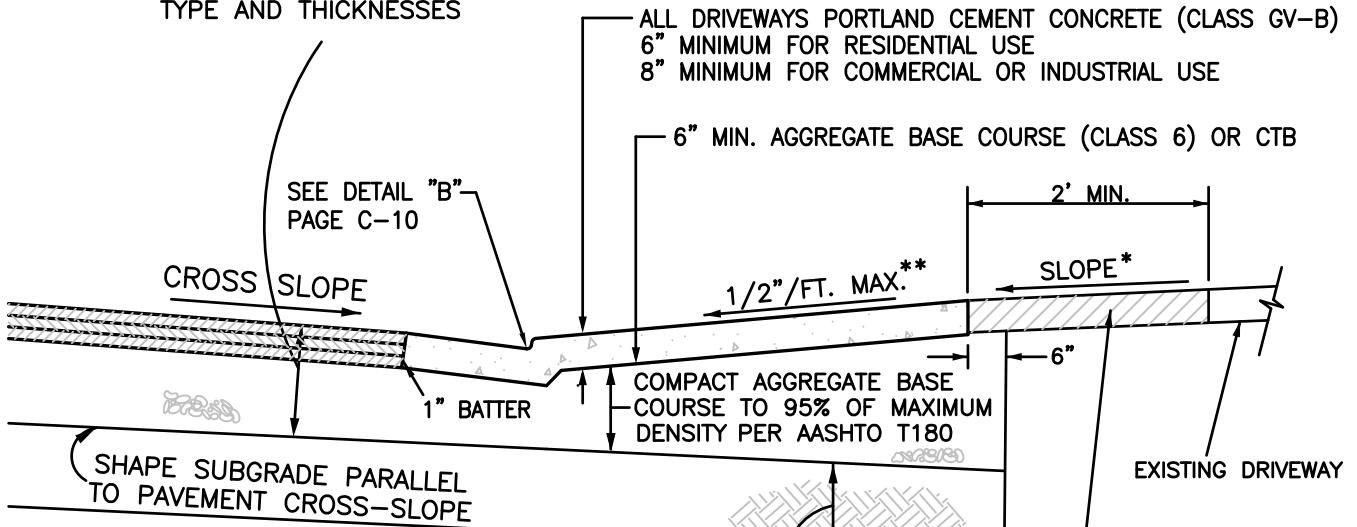

12" MIN. SUBGRADE RECONDITIONING OR CEMENT TREATED BASE (CTB). COMPACTION SHALL COMPLY WITH THE FOLLOWING UNLESS OTHERWISE SPECIFIED OR DIRECTED BY THE ENGINEER:

RECONDITIDIONING: SUBSECTION 308.17 AND 203.07 IN CDOT STANDARD SPECIFICATIONS FOR ROAD AND BRIDGE CONSTRUCTION.

CTB: SUBSECTION 308.17 IN CITY OF GRAND JUNCTION STANDARD SPECIFICATIONS FOR ROAD AND BRIDGE CONSTRUCTION.

SECTION C
C-08

SEE PROJECT PLANS FOR PAVEMENT AND BASE COURSE TYPE AND THICKNESSES

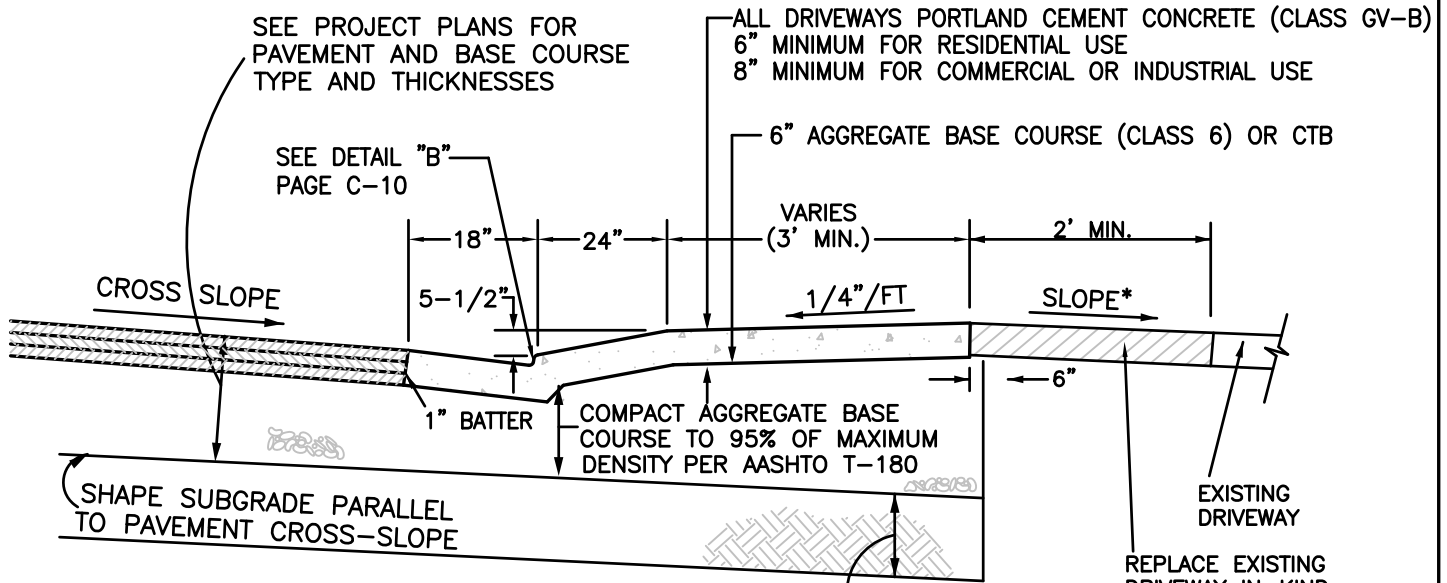

12" MIN. SUBGRADE RECONDITIONING OR CEMENT TREATED BASE (CTB). COMPACTION SHALL COMPLY WITH THE FOLLOWING UNLESS OTHERWISE SPECIFIED OR DIRECTED BY THE ENGINEER:

RECONDITIDIONING: SUBSECTION 308.17 AND 203.07 IN CDOT STANDARD SPECIFICATIONS FOR ROAD AND BRIDGE CONSTRUCTION.

CTB: SUBSECTION 308.17 IN CITY OF GRAND JUNCTION STANDARD SPECIFICATIONS FOR ROAD AND BRIDGE CONSTRUCTION.

SECTION D
D-09

DRIVEWAY SECTIONS C AND D (MONOLITHIC CURB, GUTTER AND SIDEWALK)

DEPARTMENT OF PUBLIC WORKS AND PLANNING
ENGINEERING DIVISION
CITY OF GRAND JUNCTION, COLORADO

STANDARD CONCRETE
DETAIL

APPROVED: DN
REV: JAN. 2009
DRAWN: CM

PAGE
C-11

N:\Cadd\CITY STANDARD\STANDARD DRAWING DETAILS\2008-10-Concrete Details.dwg, C-11 (REV 1-2009), 3/2/2009 1:13:13 PM

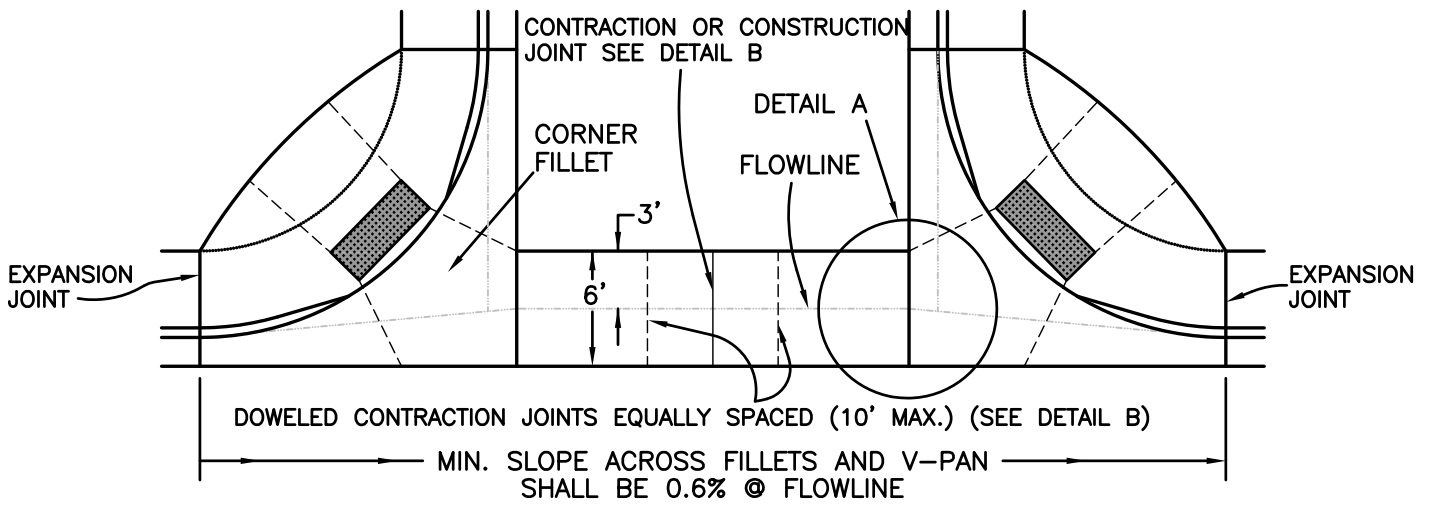

NOTE: ALL CONSTRUCTION AND CONTRACTION JOINTS IN PAN AND FILLETS SHALL BE SEALED WITH AN APPROVED CONCRETE SEALANT

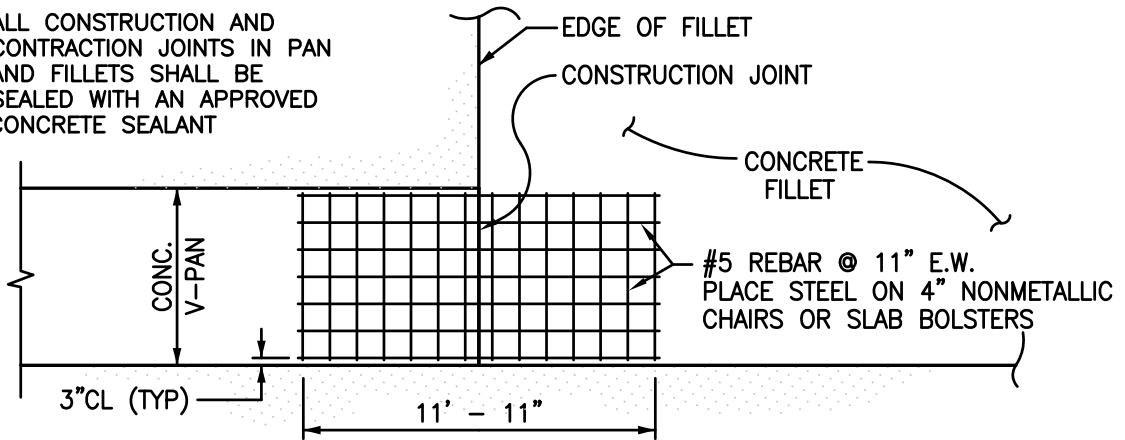

FINISHED BITUMINOUS PAVEMENT 1/4" TO 1/2" ABOVE EDGE OF PAN

SEE PROJECT PLANS FOR PAVEMENT AND BASE COURSE SPECIFICATIONS AND THICKNESSES.

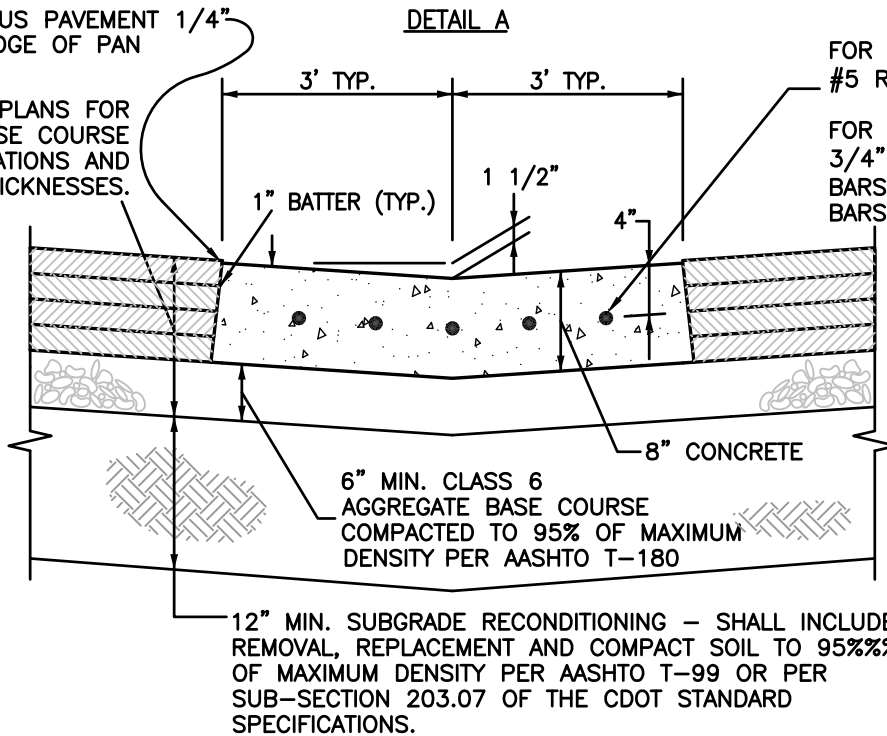

DETAIL B

CONTRACTION/CONSTRUCTION JOINT DETAIL

V-PAN DETAIL AND JOINT REINFORCEMENT

DEPARTMENT OF PUBLIC WORKS AND PLANNING
ENGINEERING DIVISION
CITY OF GRAND JUNCTION, COLORADO

STANDARD CONCRETE
DETAIL

APPROVED: DN
REVISED: JAN. 2009
DRAWN: TLT

PAGE
C-12

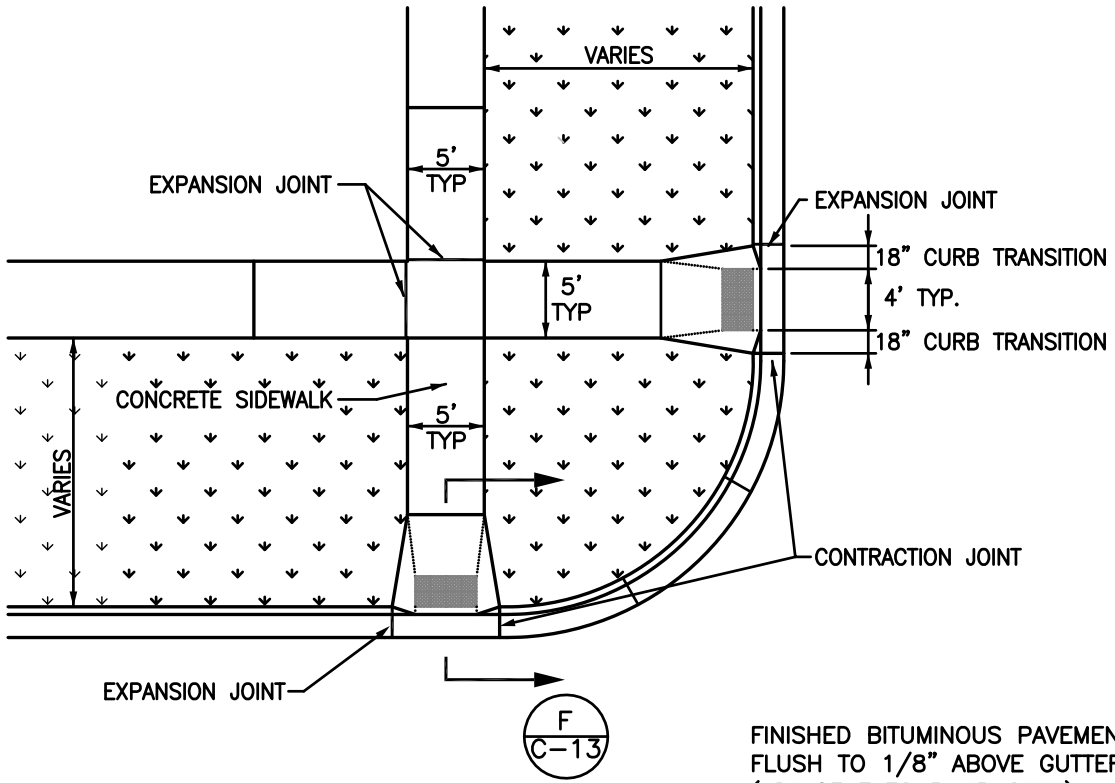

FINISHED BITUMINOUS PAVEMENT
FLUSH TO 1/8" ABOVE GUTTER EDGE
(ADJACENT TO RAMP ONLY)

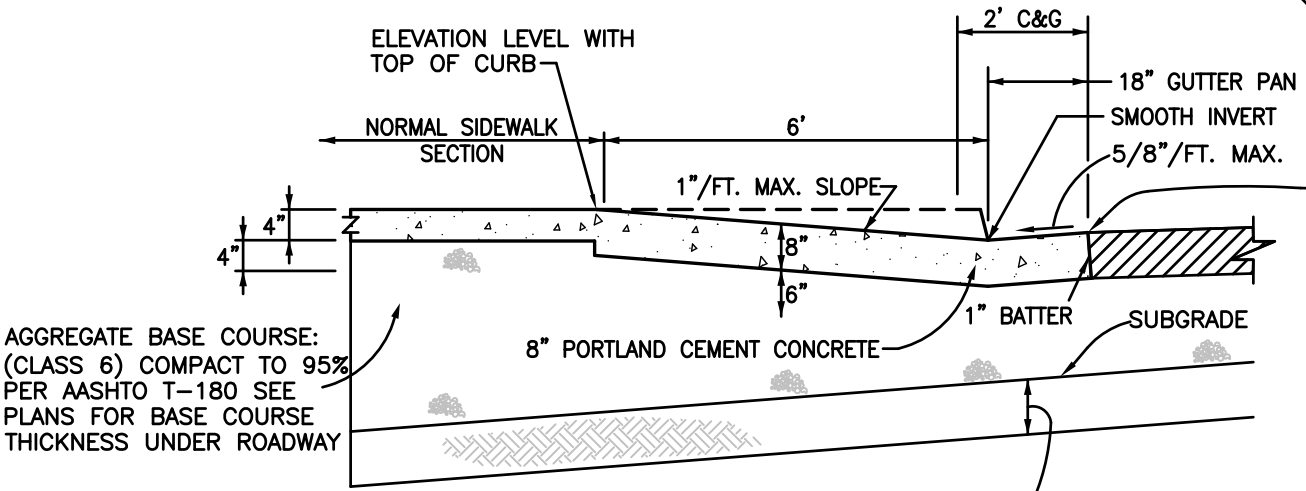

AGGREGATE BASE COURSE:
(CLASS 6) COMPACT TO 95%
PER AASHTO T-180 SEE
PLANS FOR BASE COURSE
THICKNESS UNDER ROADWAY

12" MIN. SUBGRADE RECONDITIONING - SHALL
INCLUDE REMOVAL, REPLACEMENT AND COMPACT
SOIL TO 95% OF MAXIMUM DENSITY PER AASHTO
T-99 OR PER SUB-SECTION 203.07 OF THE CDOT
STANDARD SPECIFICATIONS.

SECTION F
C-13

PERPENDICULAR CURB RAMP AT INTERSECTION

DEPARTMENT OF PUBLIC WORKS AND PLANNING ENGINEERING DIVISION CITY OF GRAND JUNCTION, COLORADO	STANDARD CONCRETE DETAIL	APPROVED: <u>DN</u> REVISED: <u>FEB, 2007</u> DRAWN: <u>TLT</u>
		PAGE C-13

N:\Cadd\CITY STANDARDS\STANDARD DRAWING DETAILS\2008 October Revisions\2008-10-Concrete Details.dwg, C-13 (REV 3-2007), 3/2/2009 1:19:29 PM

THE FOLLOWING NOTES APPLY TO PAGES C-15 THROUGH C-24

1. CONCRETE WITHIN CORNER RADIUS SHALL BE 8" THICK FROM CURB RETURN TO CURB RETURN INCLUDING THE FILLET, CURB GUTTER AND SIDEWALK, LANDING AND RAMP.
2. A 4' WIDE LANDING SHALL BE INSTALLED BEHIND EACH CURB RAMP UNLESS OTHERWISE SPECIFIED OR APPROVED. SEE PAGE C-21 FOR ALTERNATE RAMP WITHOUT LANDING.
3. DASHED LINES SHOWING CURB RAMPS AND DIMENSIONAL BACK OF WALK ARE FOR INFORMATION ONLY AND ARE NOT JOINT PATTERNS. CONTRACTION JOINTS ARE SHOWN AS SCREENED LINES ON EACH DETAIL.
4. SEE SHEET C-13 AND C-20 FOR SLOPE ON RAMPS.
5. RAMP OPENING WIDTH AT FLOWLINE GUTTER SHALL BE 4' UNLESS OTHERWISE SPECIFIED.
6. CONTROL JOINT SHALL HAVE THE SAME MEANING AS CONTRACTION JOINT.

GENERAL NOTES – APPLIES TO ALL CURB RETURN JOINT SHEETS

DEPARTMENT OF PUBLIC WORKS AND PLANNING
ENGINEERING DIVISION
CITY OF GRAND JUNCTION, COLORADO

STANDARD CONCRETE
DETAIL

APPROVED: DN
REVISED: JAN. 2009
DRAWN: TLT

PAGE
C-14

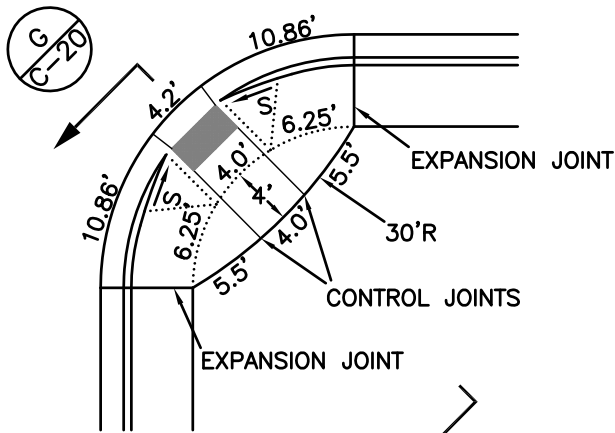

WITHOUT FILLET

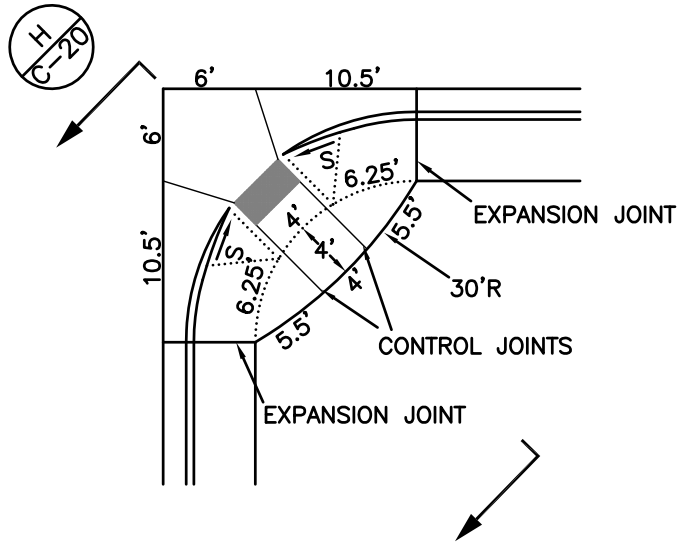

WITH FILLET

CURB TRANSITION SLOPE (S) = 10:1 MAX.

LEGEND

..... REPRESENTS GRADE BREAK

NOTE:

THE 15' CURB RADIUS IS NOT A CURRENT STANDARD. WHERE PRACTICAL, THE RADIUS SHOULD BE INCREASED TO 20'. OTHERWISE USE THESE DETAILS FOR REPLACEMENT OR RETROFIT ONLY.

CURB RETURN JOINTS - 15' RADIUS FACE OF CURB

DEPARTMENT OF PUBLIC WORKS AND PLANNING
ENGINEERING DIVISION
CITY OF GRAND JUNCTION, COLORADO

STANDARD CONCRETE
DETAIL

APPROVED: DN
REV: JAN. 2009
DRAWN: JAH

PAGE
C-15

N:\Cadd\CITY STANDARDS\STANDARD DRAWING DETAILS\2008-10-Concrete Details.dwg, C-16 (REV 1-2009), 3/2/2009 1:21:35 PM

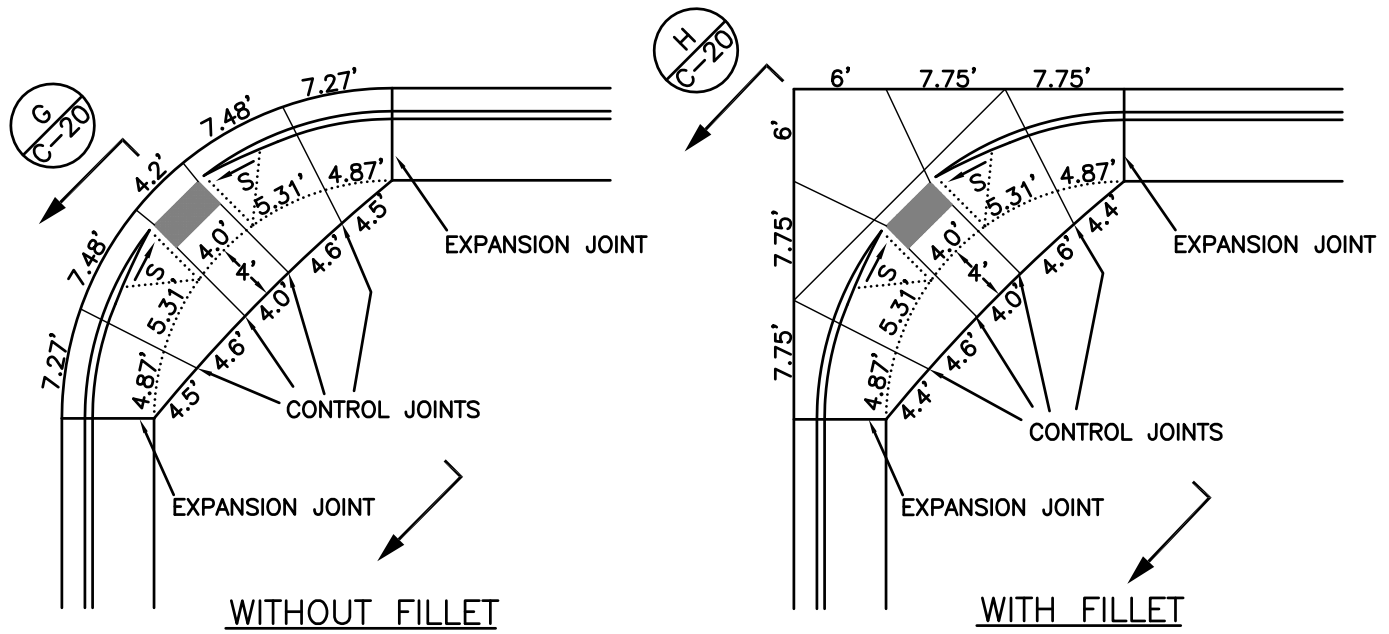

CURB TRANSITION SLOPE (S) = 10:1 MAX.

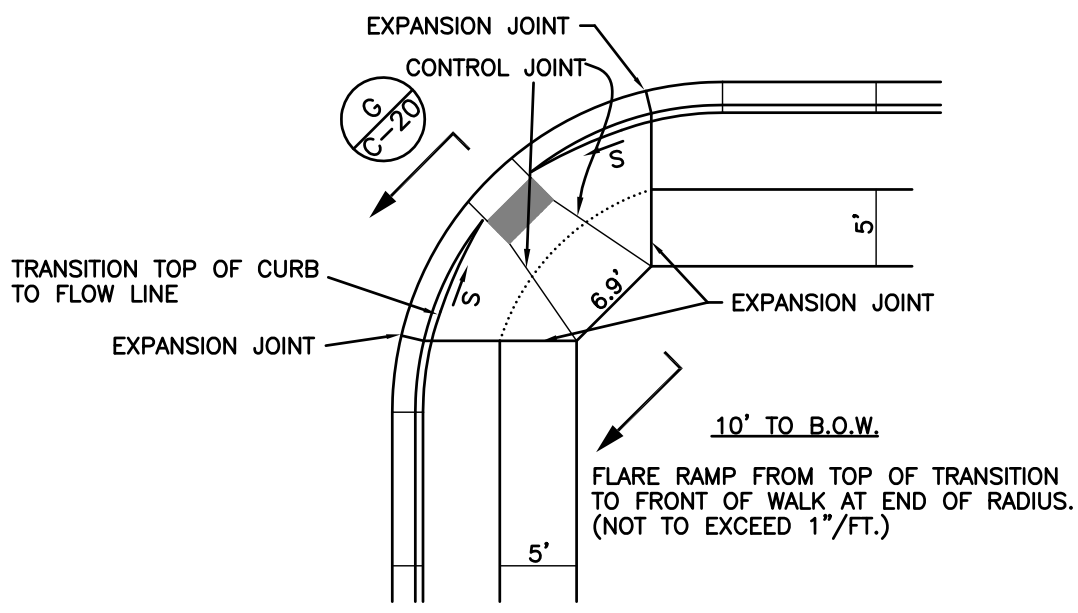

DETACHED SIDEWALK

LEGEND

..... REPRESENTS GRADE BREAK

CURB RETURN JOINTS - 20' RADIUS FACE OF CURB

DEPARTMENT OF PUBLIC WORKS AND PLANNING ENGINEERING DIVISION CITY OF GRAND JUNCTION, COLORADO	STANDARD CONCRETE DETAIL	APPROVED: <u>DN</u> DATE: <u>JAN. 2009</u> DRAWN: <u>CM</u>	PAGE C-16
---	-----------------------------	---	--------------

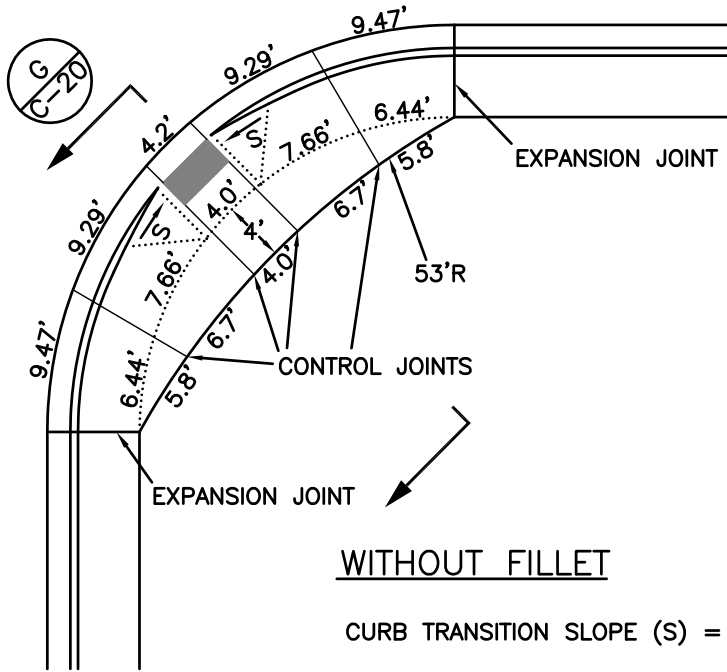

WITHOUT FILLET

CURB TRANSITION SLOPE (S) = 10:1 MAX.

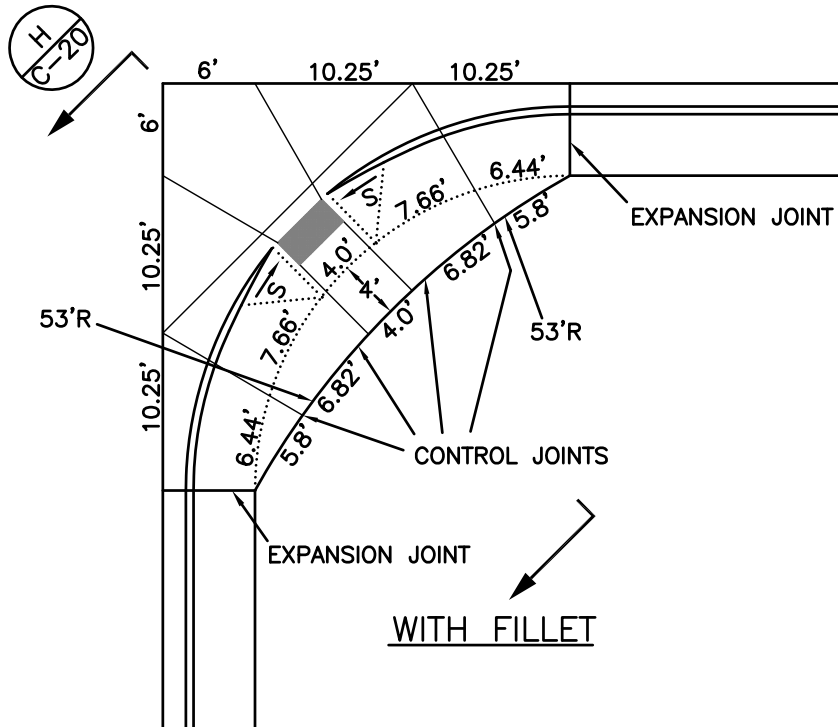

WITH FILLET

LEGEND

..... REPRESENTS GRADE BREAK

CURB RETURN JOINTS - 25' RADIUS FACE OF CURB

DEPARTMENT OF PUBLIC WORKS AND PLANNING
ENGINEERING DIVISION
CITY OF GRAND JUNCTION, COLORADO

STANDARD CONCRETE
DETAIL

APPROVED: DN
REV: JAN 2009
DRAWN: DPW

PAGE
C-17

N:\Cadd\CITY STANDARDS\STANDARD DRAWING DETAILS\2008 October Revisions\2008-10-Concrete Details.dwg, C-18 (REV 1-2009), 3/2/2009 1:22:30 PM

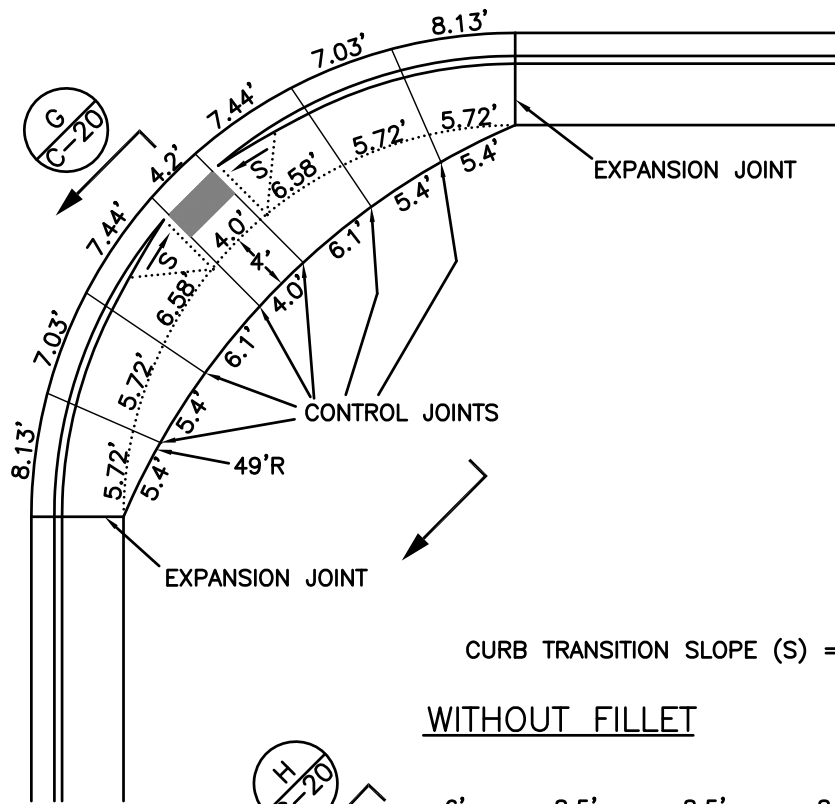

WITHOUT FILLET

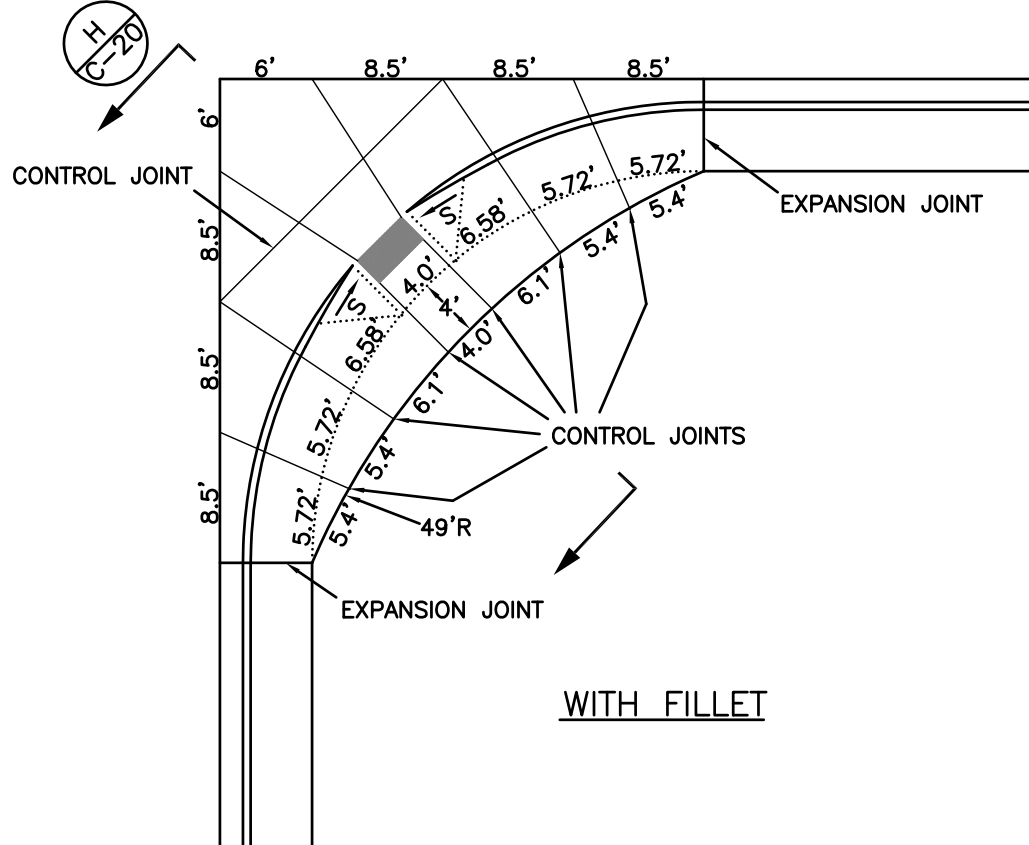

WITH FILLET

LEGEND

..... REPRESENTS GRADE BREAK

CURB RETURN JOINTS - 30' RADIUS FACE OF CURB

DEPARTMENT OF PUBLIC WORKS AND PLANNING ENGINEERING DIVISION CITY OF GRAND JUNCTION, COLORADO	STANDARD CONCRETE DETAIL	APPROVED: <u>DN</u> REV: <u>JAN. 2009</u> DRAWN: <u>JAF</u>	PAGE C-18
---	-----------------------------	---	--------------

N:\Cadd\CITY STANDARDS\STANDARD DRAWING DETAILS\2008 October Revisions\2008-10-Concrete Details.dwg, C-19 (REV 1-2009), 3/2/2009 1:23:03 PM

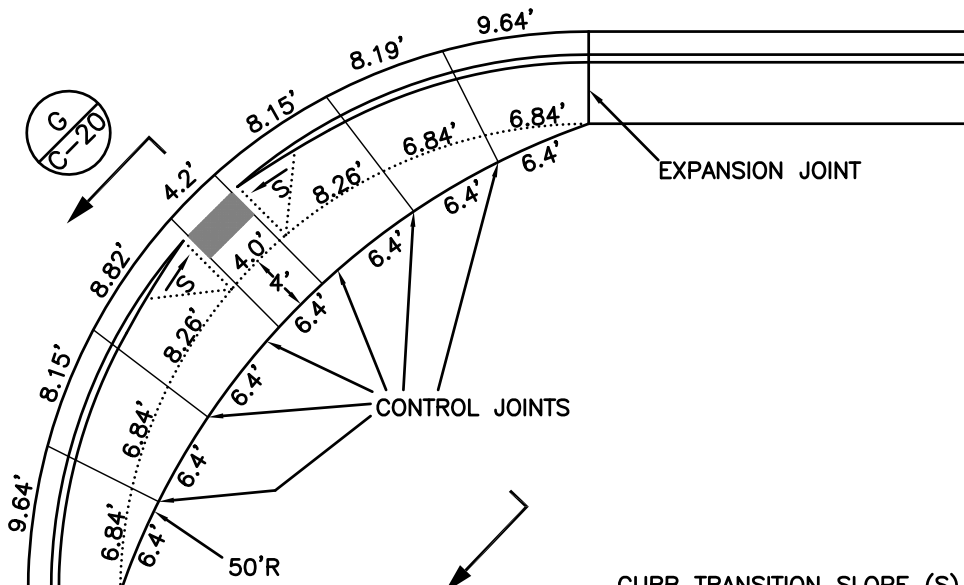

CURB TRANSITION SLOPE (S) = 10:1 MAX.

WITHOUT FILLET

EXPANSION JOINT

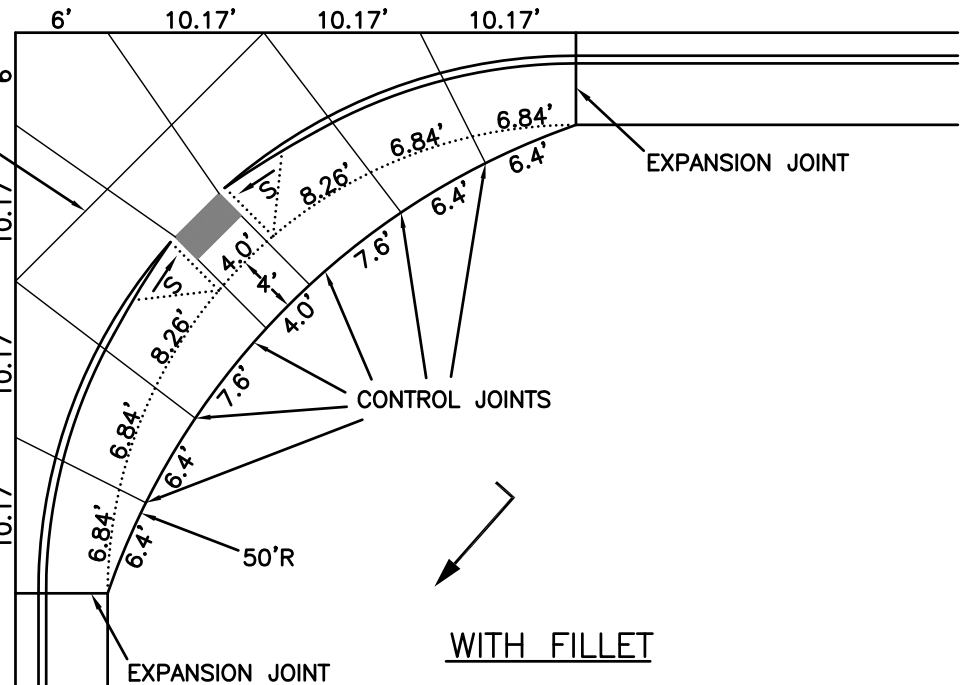

WITH FILLET

LEGEND

..... REPRESENTS GRADE BREAK

CURB RETURN JOINTS - 35' RADIUS FACE OF CURB

DEPARTMENT OF PUBLIC WORKS AND PLANNING
ENGINEERING DIVISION
CITY OF GRAND JUNCTION, COLORADO

STANDARD CONCRETE
DETAIL

APPROVED: DN
DATE: JAN. 2009
DRAWN: JAH

PAGE
C-19

CURB TRANSITION SLOPE (S) = 10:1 MAX.

SEE PROJECT PLANS FOR PAVEMENT AND BASE COURSE TYPE AND THICKNESSES

PERPENDICULAR CURB RAMP WITH LANDING

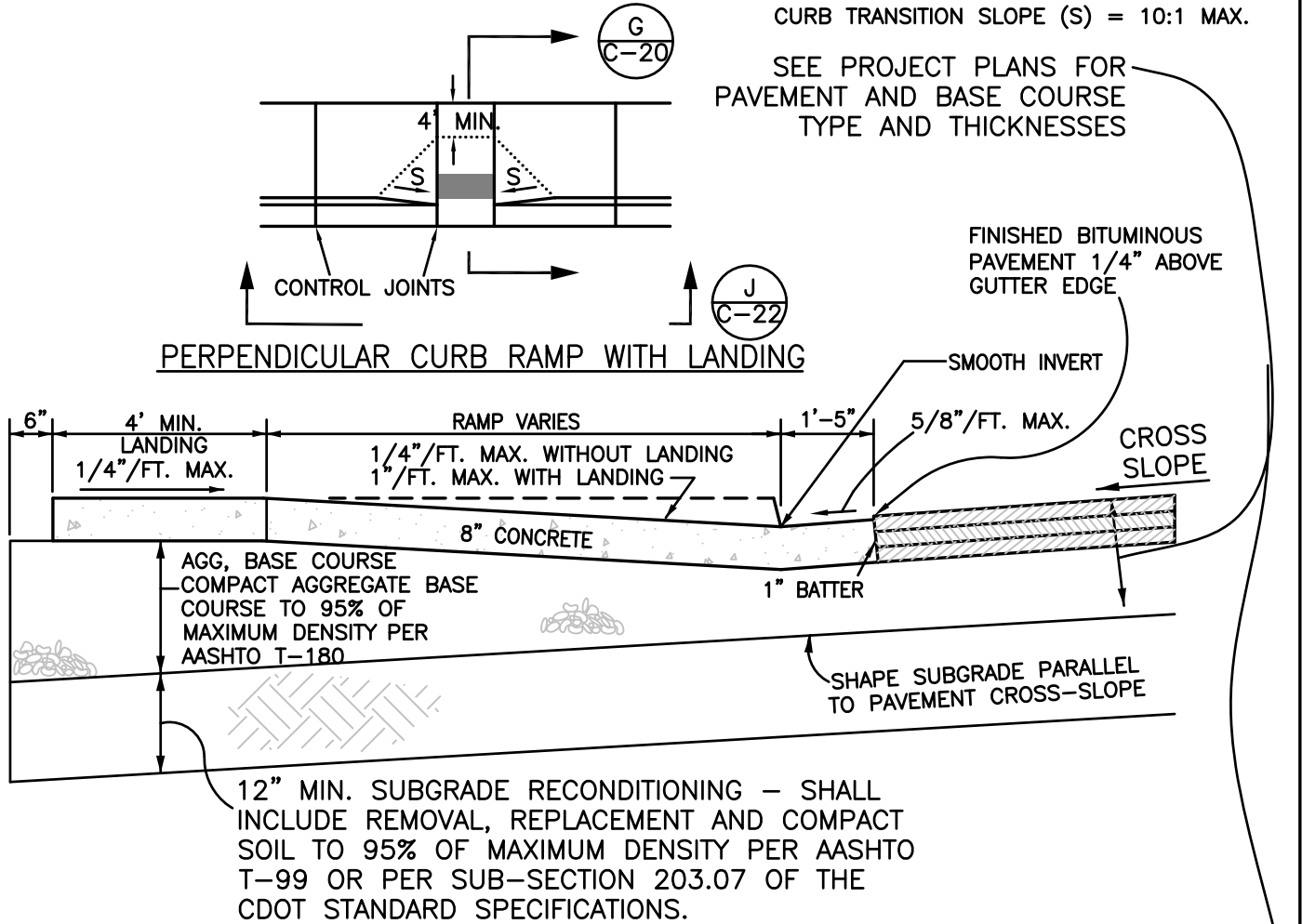

12" MIN. SUBGRADE RECONDITIONING - SHALL INCLUDE REMOVAL, REPLACEMENT AND COMPACT SOIL TO 95% OF MAXIMUM DENSITY PER AASHTO T-99 OR PER SUB-SECTION 203.07 OF THE CDOT STANDARD SPECIFICATIONS.

SECTION G (WITHOUT FILLET)

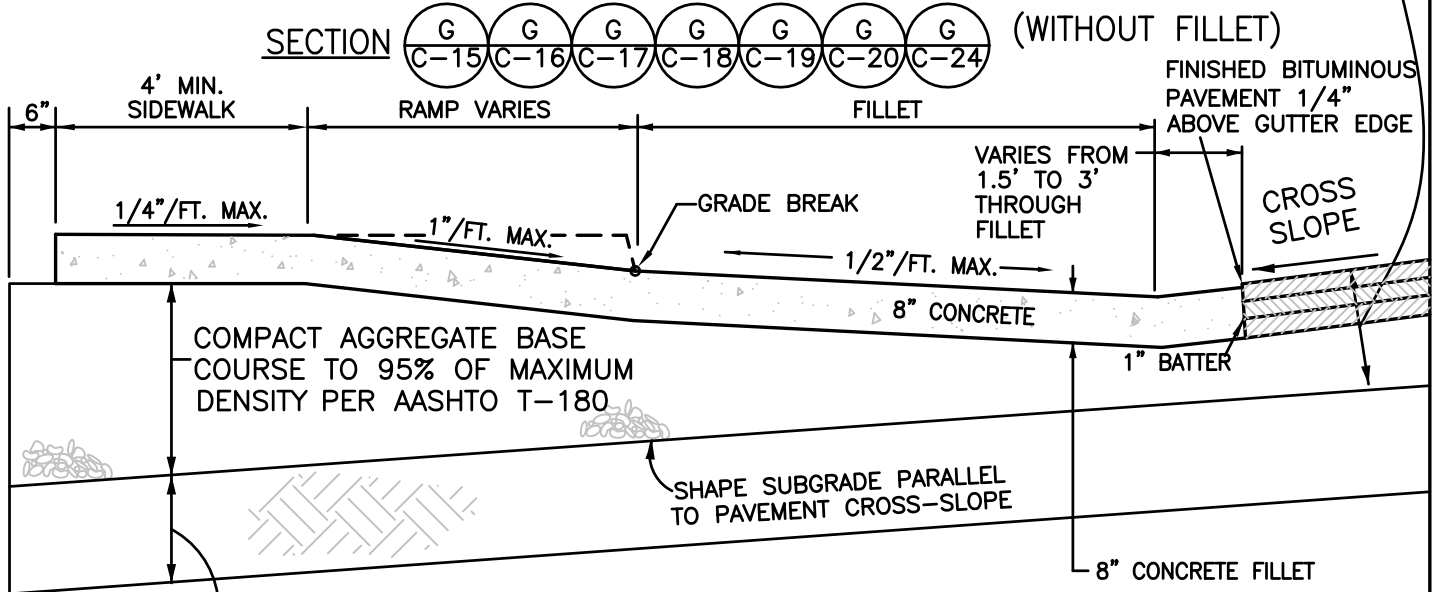

12" MIN. SUBGRADE RECONDITIONING - SHALL INCLUDE REMOVAL, REPLACEMENT AND COMPACT SOIL TO 95% OF MAXIMUM DENSITY PER AASHTO T-99 OR PER SUB-SECTION 203.07 OF THE CDOT STANDARD SPECIFICATIONS.

SECTION H (WITH FILLET)

PERPENDICULAR CURB RAMP AND SECTIONS G AND H

N:\Cadd\CITY STANDARDS\STANDARD DRAWING DETAILS\2008 October Revisions\2008-10-Concrete Details.dwg, C-20 (REV 1-2009), 3/2/2009 10:41:10 AM

N:\Cadd\CITY STANDARDS\STANDARD DRAWING DETAILS\2008 October Revisions\2008-10-Concrete Details.dwg, C-21 (REV 1-2009), 3/2/2009 10:52:34 AM

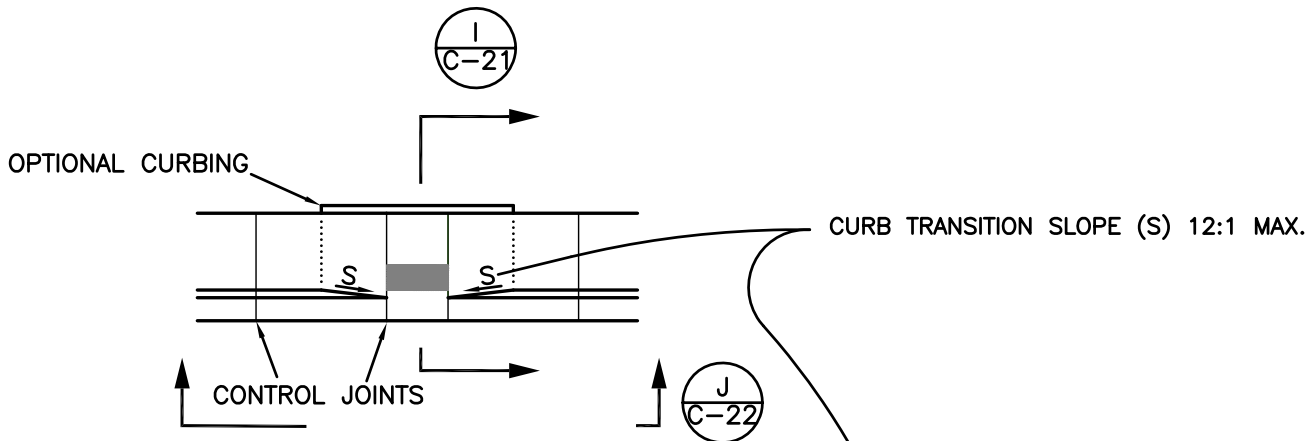

WITHOUT LANDING BEHIND RAMP
(FOR RETROFIT ON EXISTING STREETS ONLY)
ALTERNATE RAMP (STRAIGHT)

NOTE:
FOR JOINT DETAILS, SEE
SHEETS C-13 THROUGH C-19

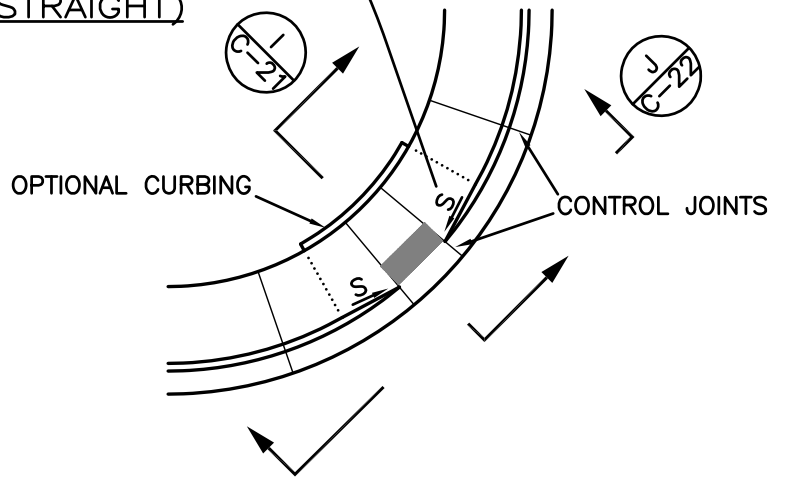

WITHOUT LANDING BEHIND RAMP
(FOR RETROFIT ON EXISTING STREETS ONLY)
ALTERNATE RAMP (CURVE)

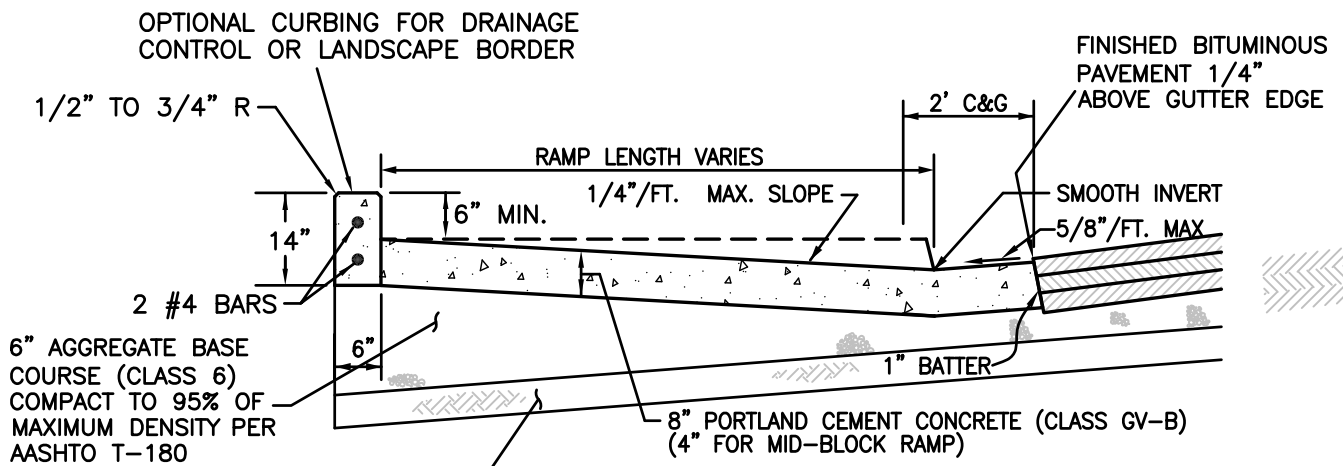

12" MIN. SUBGRADE RECONDITIONING - SHALL INCLUDE
REMOVAL, REPLACEMENT AND COMPACT SOIL TO 95% OF
MAXIMUM DENSITY PER AASHTO T-99 OR PER SUB-SECTION
203.07 OF THE CDOT STANDARD SPECIFICATIONS.

SECTION I
C-21

ALTERNATE RAMP WITHOUT LANDING

DEPARTMENT OF PUBLIC WORKS AND PLANNING ENGINEERING DIVISION CITY OF GRAND JUNCTION, COLORADO	STANDARD CONCRETE DETAIL	APPROVED: <u>DN</u> REV: <u>JAN. 2009</u> DRAWN: <u>CM</u>	PAGE C-21
---	-----------------------------	--	--------------

1
C-21

SEE OPTIONAL CURB AT BACK OF WALK ON

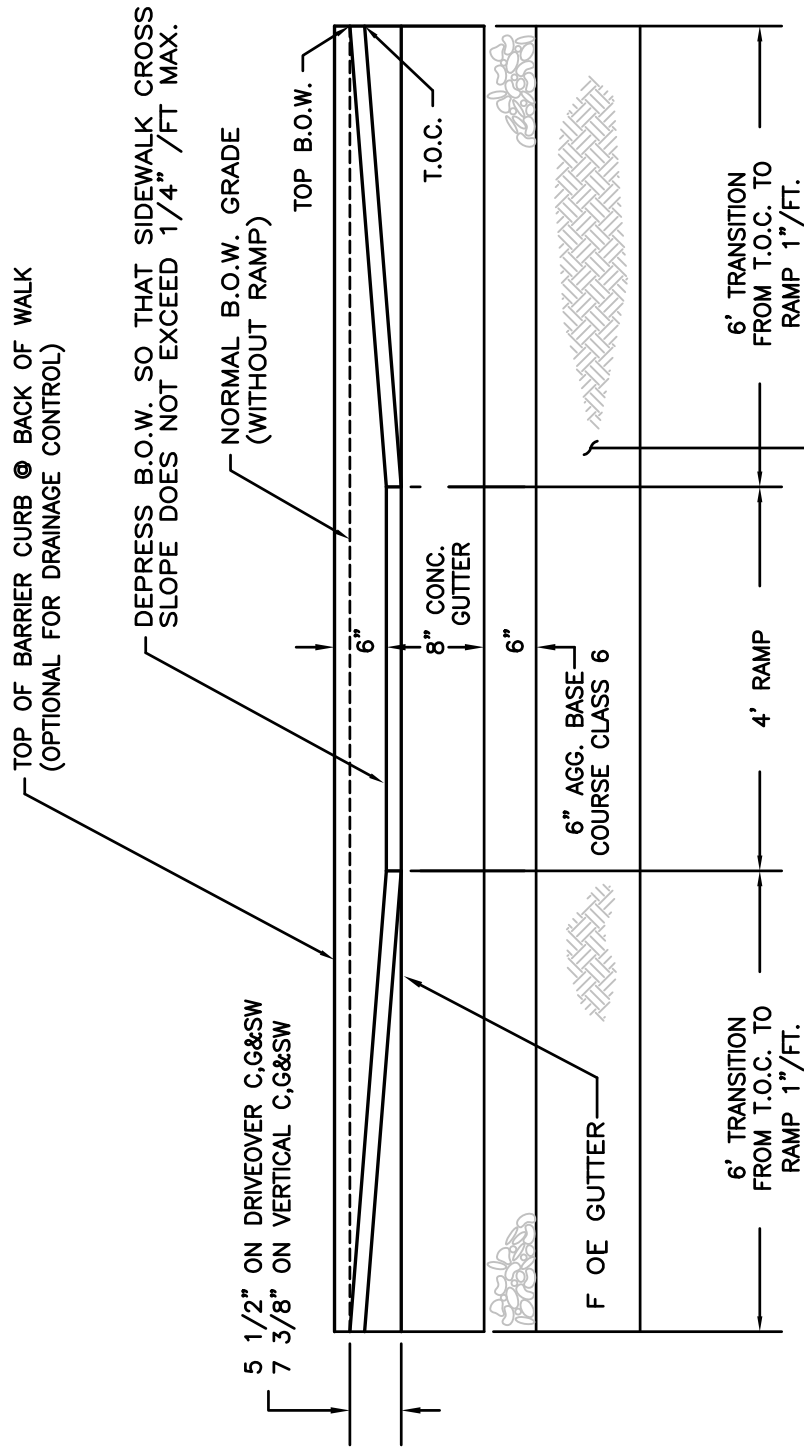

J
SECTION
C-21

12" MIN. SUBGRADE RECONDITIONING - SHALL INCLUDE REMOVAL, REPLACEMENT AND COMPACT SOIL TO 95% OF MAXIMUM DENSITY PER AASHTO T-99 OR PER SUB-SECTION 203.07 OF THE CDOT STANDARD SPECIFICATIONS.

CURB RAMP (FRONT VIEW)

DEPARTMENT OF PUBLIC WORKS AND PLANNING ENGINEERING DIVISION CITY OF GRAND JUNCTION, COLORADO	STANDARD CONCRETE DETAIL	APPROVED: <u>DN</u> REVISED: <u>FEB. 2009</u> DRAWN: <u>TLT</u>	PAGE C-22
---	-----------------------------	---	--------------

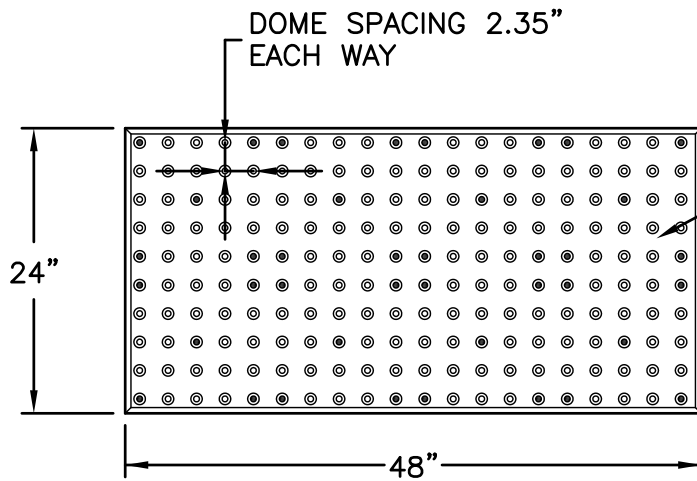
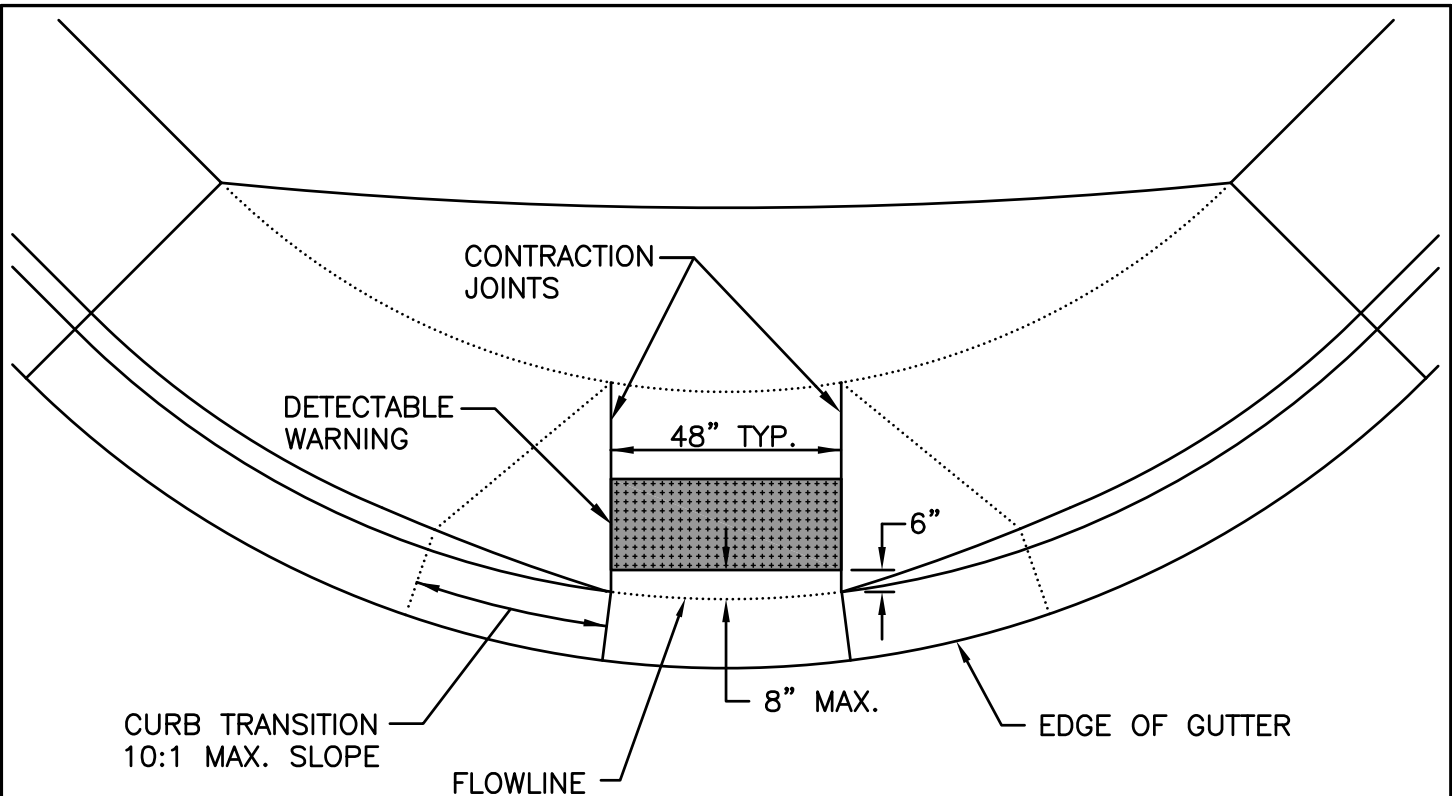

DETECTABLE WARNING WITH IN-LINE DOME PATTERN.

ALL DETECTABLE WARNING EXCEPT CAST IRON PLATES SHALL BE BRICK RED IN COLOR.

NOTE: YELLOW DETECTABLE WARNINGS ARE BEING PHASED OUT AND WILL NOT BE ALLOWED FOR NEW INSTALLATIONS AFTER DECEMBER 31, 2009

DETECTABLE WARNING:

AN APPROVED DETECTABLE WARNING SHALL BE "WET SET" INTO THE FRESHLY FINISHED CONCRETE SURFACE OF EACH NEW CURB RAMP. SURFACE APPLIED DETECTABLE WARNINGS MAY BE USED ONLY FOR RETROFITTING PRE-EXISTING CURB RAMPS. SEE SECTION 608.03, PARAGRAPH (j) OF THE CITY OF GRAND JUNCTION STANDARD SPECIFICATIONS FOR ROAD AND BRIDGE CONSTRUCTION FOR APPROVED DETECTABLE WARNING MATERIALS AND MANUFACTURES. DETECTABLE WARNING SHALL BE INSTALLED IN ACCORDANCE WITH THE MANUFACTURERS INSTRUCTIONS UNLESS OTHERWISE APPROVED.

DETECTABLE WARNING FOR CURB RAMP

DEPARTMENT OF PUBLIC WORKS AND PLANNING
ENGINEERING DIVISION
CITY OF GRAND JUNCTION, COLORADO

STANDARD CONCRETE
DETAIL

APPROVED: DN
REVISED: FEB. 2008
DRAWN: TLT

PAGE
C-23

SEE PAGE C-21 FOR ALTERNATE RAMP WITHOUT LANDING

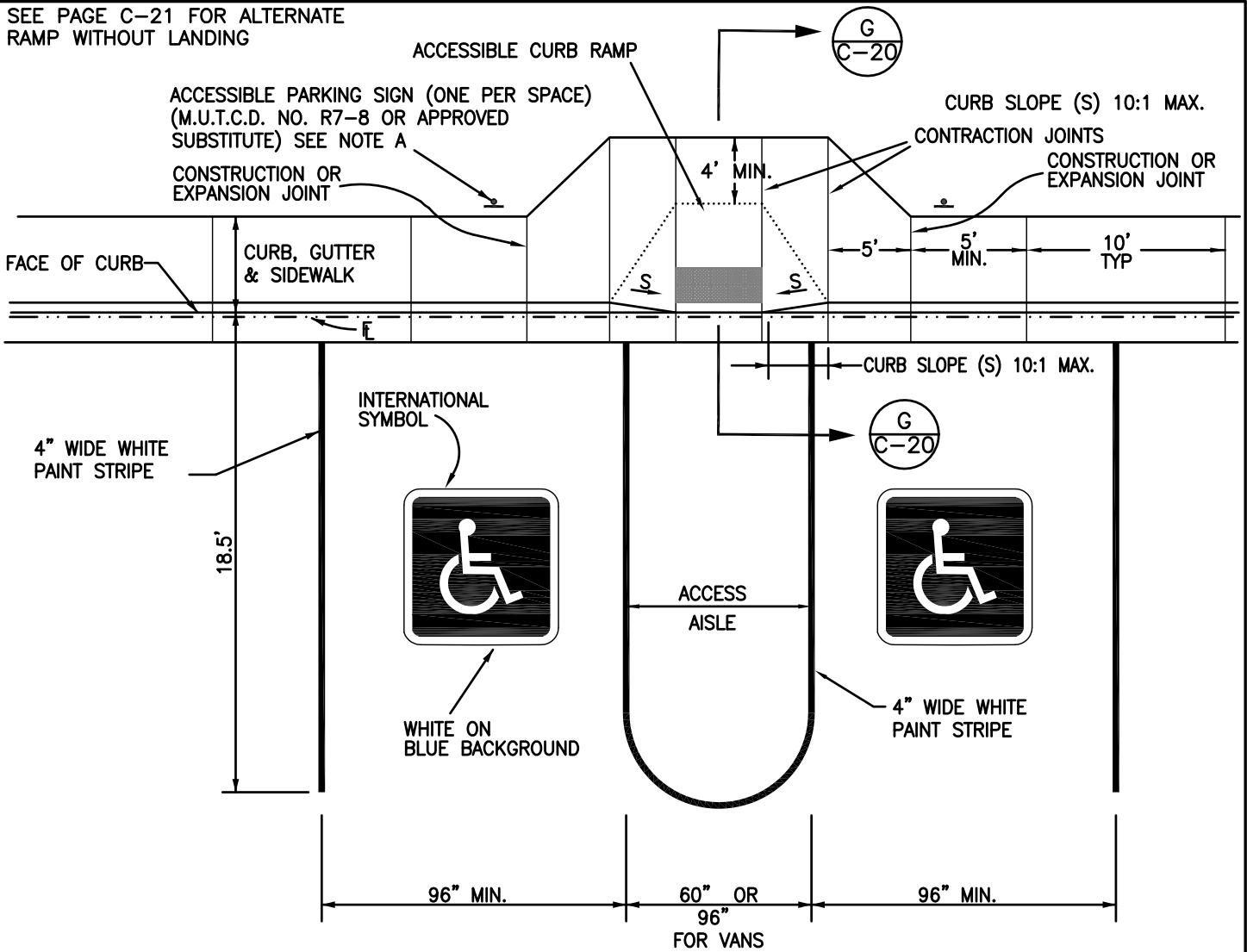

NOTES:

- A. ACCESSIBLE PARKING SPACES SHALL BE DESIGNATED AS RESERVED FOR THE DISABLED BY A SIGN SHOWING THE SYMBOL OF ACCESSIBILITY (SEE MUTCD FIGURE 3B-19). SPACES COMPLYING WITH NOTE B SHALL HAVE AN ADDITIONAL SIGN "VAN ACCESSIBLE" MOUNTED BELOW THE SYMBOL OF ACCESSIBILITY. SUCH SIGNS SHALL BE MOUNTED SO THEY CANNOT BE OBSCURED BY A VEHICLE PARKED IN THE SPACE.
- B. ONE IN EVERY EIGHT ACCESSIBLE SPACES, BUT NOT LESS THAN ONE, SHALL BE SERVED BY AN ACCESS AISLE 96" WIDE AND SHALL BE DESIGNATED "VAN ACCESSIBLE" AS SPECIFIED BY NOTE A.
- C. PARKING ACCESS AISLES SHALL BE PART OF AN ACCESS ROUTE TO THE BUILDING OR FACILITY ENTRANCE. TWO ACCESSIBLE PARKING SPACES MAY SHARE A COMMON ACCESS AISLE. PARKING SPACES AND ACCESS AISLES SHALL BE LEVEL WITH SURFACE SLOPES NOT EXCEEDING 1:50 IN ALL DIRECTIONS.
- D. ACCESSIBLE CURB RAMPS AT INTERSECTIONS SHALL BE ALIGNED WITH STREET CROSSWALKS.
- E. THE MAXIMUM LONGITUDINAL SLOPE ALLOWED ON ANY CURB RAMP OR SIDEWALK SHALL BE 1"/FT. (8.33%). THE MAXIMUM CROSS SLOPE ALLOWED ON ANY WALKING ROUTE IS 1:50 (2%) (1/4"/FT.)
- F. THE SURFACE OF ALL ACCESSIBLE RAMPS AND FLARED SIDES SHALL BE FINISHED WITH A COURSE BROOMED TEXTURE PERPENDICULAR TO THE SLOPE OF THE RAMP.
- G. ALL HANDICAP RAMPS, PARKING STALLS AND LANDINGS, SHALL CONFORM TO THE UNIFORM FEDERAL ACCESSIBILITY STANDARDS (UFAS) LATEST EDITION.

STANDARD ACCESSIBLE PARKING STALL

DEPARTMENT OF PUBLIC WORKS AND PLANNING
ENGINEERING DIVISION
CITY OF GRAND JUNCTION, COLORADO

STANDARD CONCRETE
DETAIL

APPROVED: DN
REV: FEB. 2005
DRAWN: DPW

PAGE
C-24

N:\Cadd\CITY STANDARDS\STANDARD DRAWING DETAILS\2008 October Revisions\2008-10-Concrete Details.dwg, C-24, 3/2/2009 9:56:38 AM

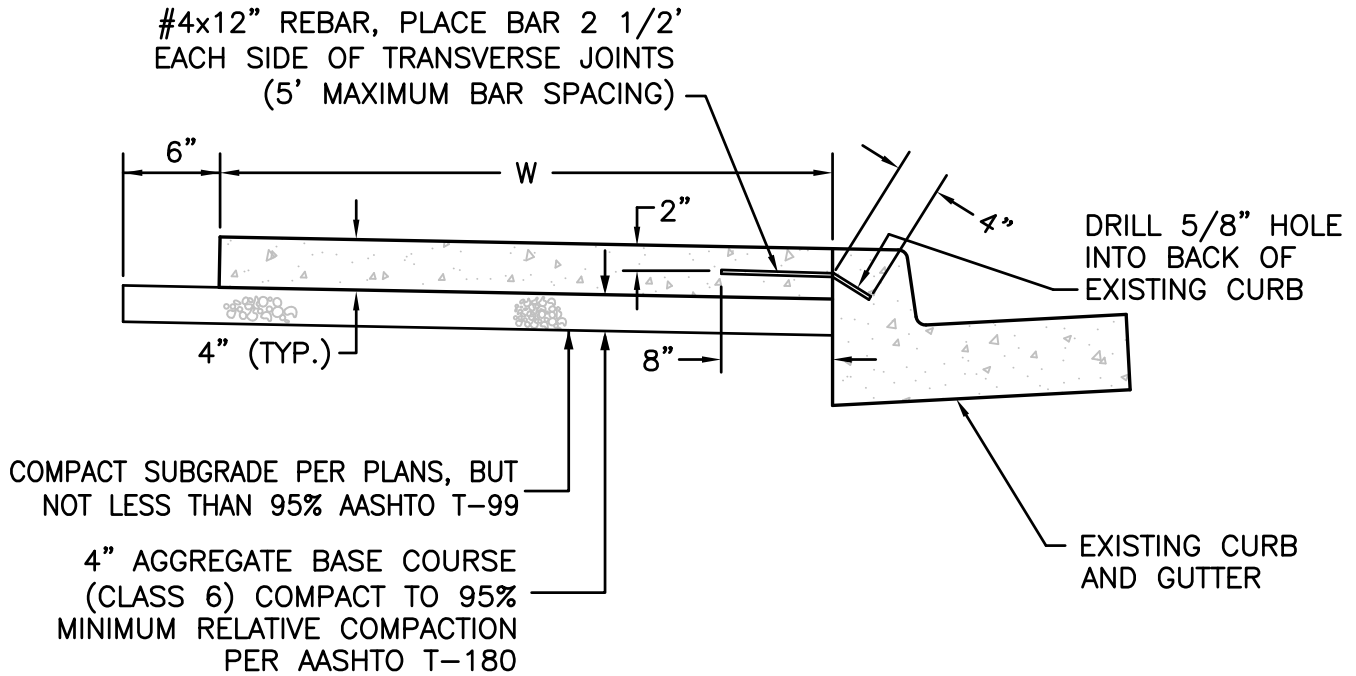

STREET CLASSIFICATION	MINIMUM SIDEWALK WIDTH (W)
RESIDENTIAL	4'
COLLECTOR OR COMMERCIAL	5'
MINOR ARTERIAL	5'
PRINCIPAL ARTERIAL	6'

SIDEWALK RETROFIT DETAIL

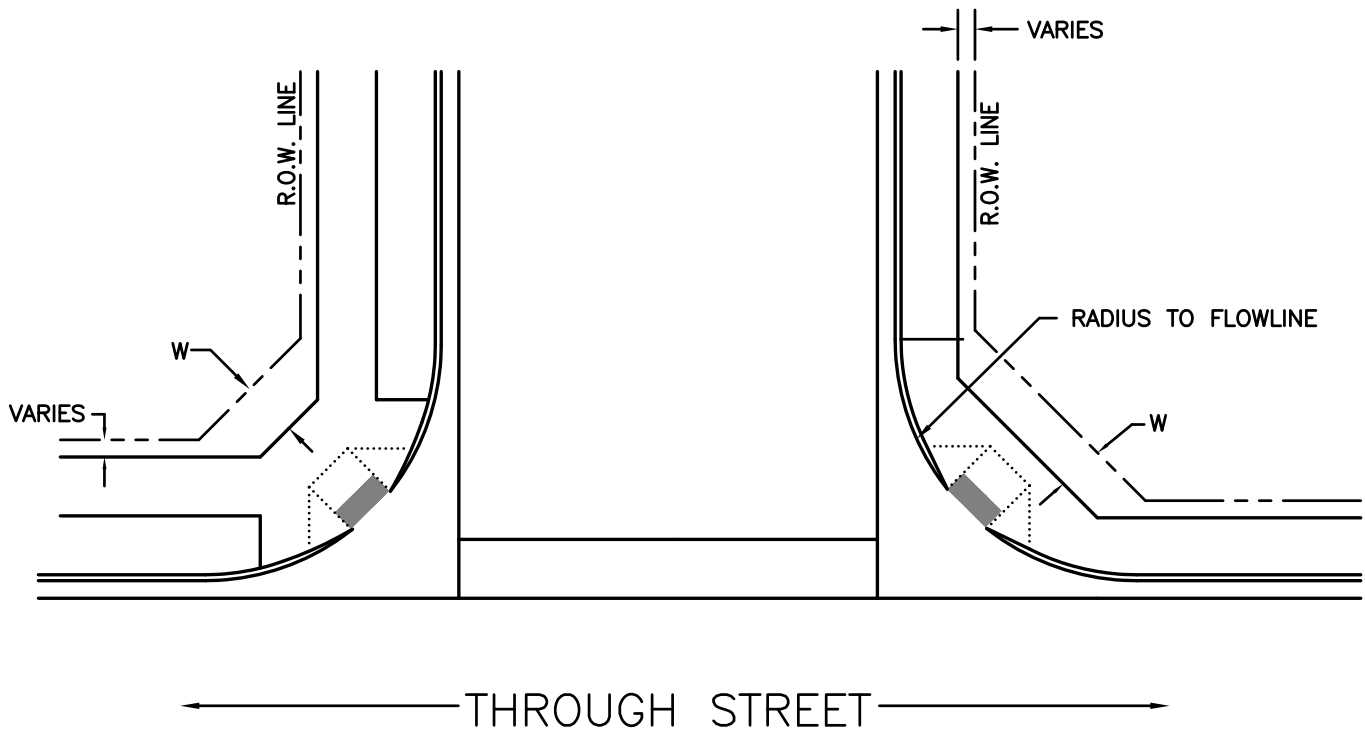

MINIMUM INTERSECTION FLOWLINE RADII						
THROUGH STREET (2)	ARTERIAL	COLLECTOR	LOCAL RESIDENTIAL	LOCAL COMMERCIAL	LOCAL INDUSTRIAL (1)	W
ARTERIAL	35'	30'	30'	30'	30'	5'
COLLECTOR	30'	30'	25'	30'	30'	5'
LOCAL RESIDENTIAL			20'			2'
LOCAL COMMERCIAL			20'	30'	30'	2'
LOCAL INDUSTRIAL				30'	30'	2'

(1) RADII AT INTERSECTIONS WITH INDUSTRIAL STREETS SHALL BE INDIVIDUALLY DESIGNED BASED ON THE TURNING REQUIREMENTS FOR THE TYPE OF TRUCK THAT WILL MOST COMMONLY USE THE STREET.

(2) AT SIGNALIZED INTERSECTIONS WHERE RIGHT TURN CHANNELIZATION ISLANDS ARE PROVIDED OR HIGH TRUCK AND BUS VOLUMES MAY USE THE ACCESS, A LARGER FLOWLINE RADIUS MAY BE REQUIRED.

RADII AND RIGHT-OF-WAY WIDTH AT INTERSECTION CORNER

DEPARTMENT OF PUBLIC WORKS AND PLANNING
ENGINEERING DIVISION
CITY OF GRAND JUNCTION, COLORADO

STANDARD CONCRETE
DETAIL

APPROVED: DN
REV: FEB. 2005
DRAWN: DPW

PAGE
C-26

N:\Cadd\CITY STANDARDS\STANDARD DRAWING DETAILS\2009 Revisions\2010-Concrete Details.dwg, C-27 (REV 3-2010), 3/15/2010 7:07:03 AM

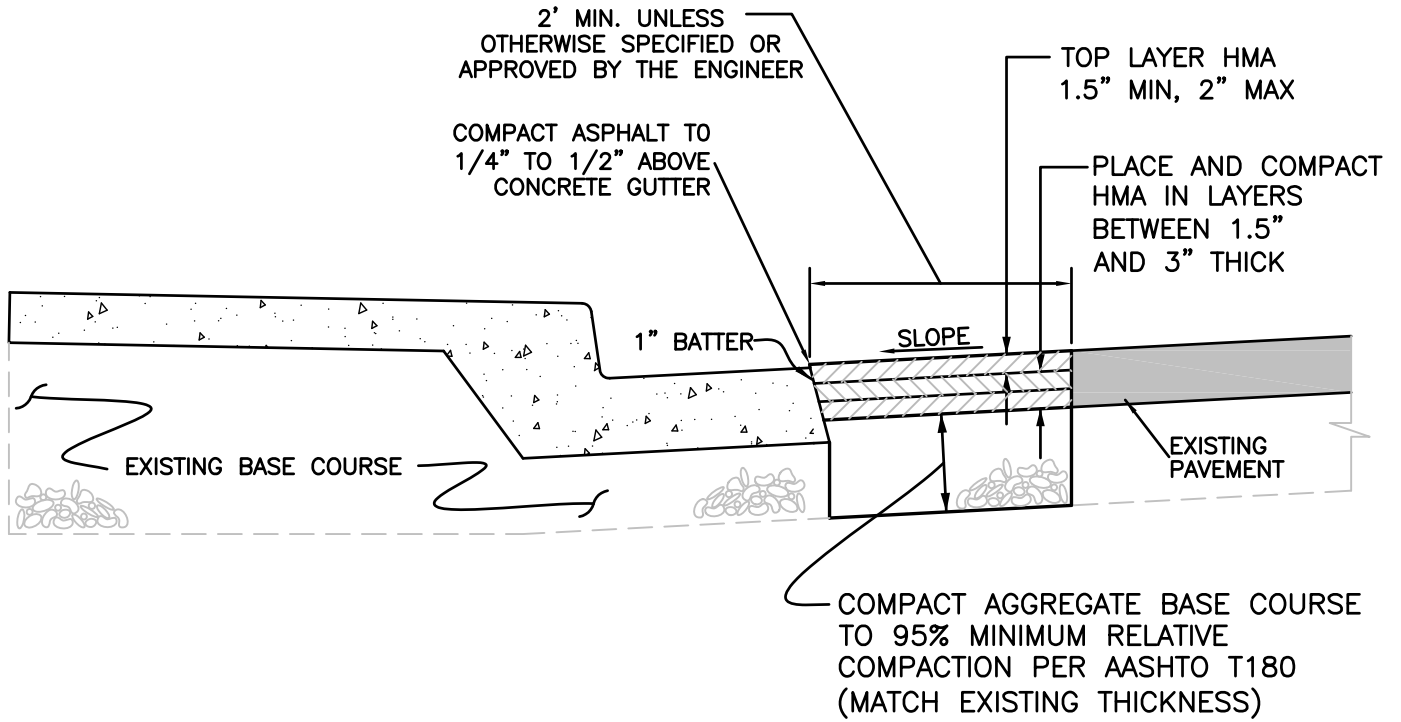

NOTE:

1. PATCH SHALL MATCH EXISTING PAVEMENT AND BASE COURSE THICKNESSES, BUT NOT LESS THAN 3" HOT MIX ASPHALT (HMA) AND 6" AGGREGATE BASE COURSE (A.B.C.). COMPACT BASE COURSE TO 95% AASHTO T-180. COMPACT ASPHALT TO BETWEEN 92% AND 96% OF MAXIMUM THEORETICAL DENSITY CP51. HMA SHALL CONFORM TO SECTION 401 OF THE STANDARD SPECIFICATIONS FOR ROAD AND BRIDGE CONSTRUCTION. THE TOP LAYER OF PATCHES THAT ARE 6' WIDE OR GREATER AND MORE THAN 100' IN LENGTH SHALL BE PAVED WITH AN ASPHALT PAVING MACHINE. SEE SUBSECTION 401.04.14 OF THE STANDARD SPECIFICATIONS FOR ROAD AND BRIDGE CONSTRUCTION FOR PATCHING SPECIFICATIONS.

2. FOR REPLACEMENT OF CONCRETE CURB AND GUTTER, PLACE CONCRETE AGAINST EXISTING ASPHALT EDGE UNLESS OTHERWISE DIRECTED OR APPROVED

ASPHALT PATCH ADJACENT TO CURB AND GUTTER

DEPARTMENT OF PUBLIC WORKS AND PLANNING
ENGINEERING DIVISION
CITY OF GRAND JUNCTION, COLORADO

STANDARD CONCRETE
DETAIL

APPROVED: DN
REVISED: MAR 2010
DRAWN: TLT

PAGE
C-27

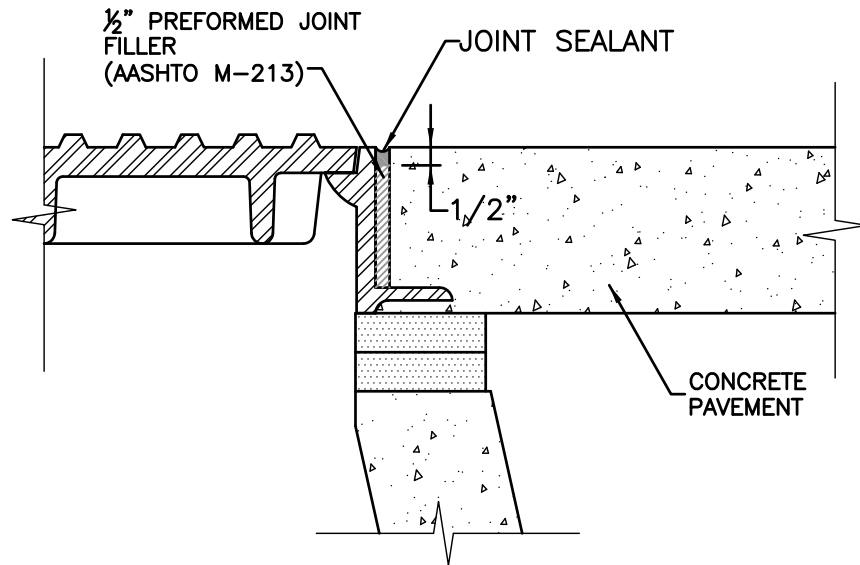

MANHOLE ISOLATION JOINT

ALL EXPANSION AND ISOLATION JOINTS IN CONCRETE PAVEMENT SHALL BE SEALED.

SEE SECTION 705.01 OF THE STANDARD SPECS. FOR ROAD AND BRIDGE CONSTRUCTION FOR APPROVED JOINT SEALANTS. SEALANT COLOR SHALL MATCH CONCRETE

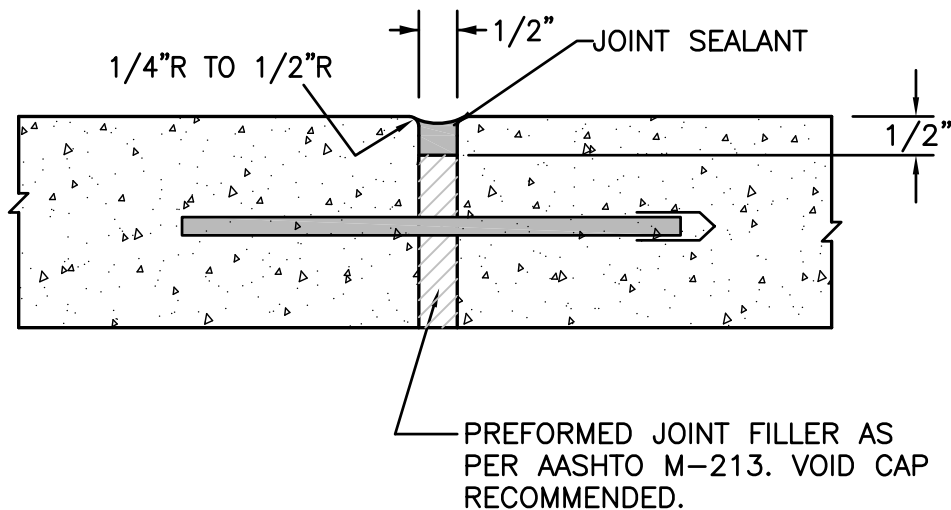

EXPANSION JOINT

JOINT SEAL FOR CONCRETE PAVEMENT

DEPARTMENT OF PUBLIC WORKS AND PLANNING
ENGINEERING DIVISION
CITY OF GRAND JUNCTION, COLORADO

STANDARD CONCRETE
DETAIL

APPROVED: DN
REV: FEB. 2005
DRAWN: DPW

PAGE
C-28

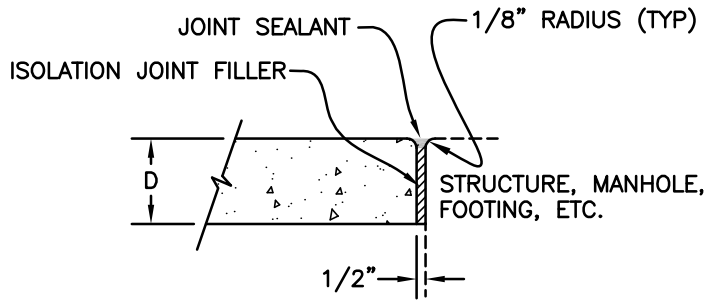
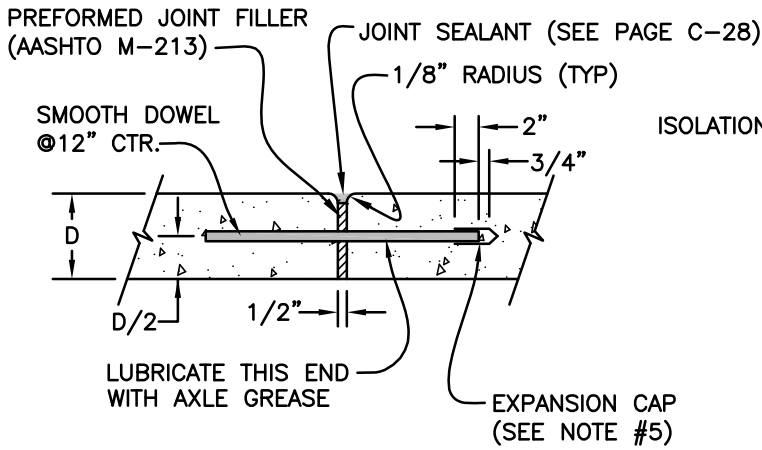

UNDOWELED ISOLATION JOINT

DOWELED ISOLATION OR EXPANSION JOINT

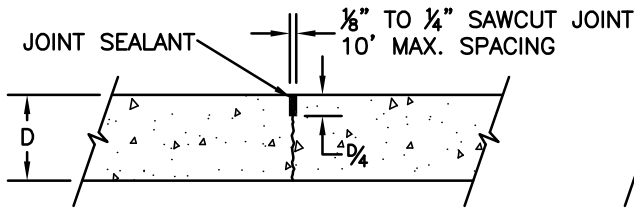

CONTRACTION JOINT

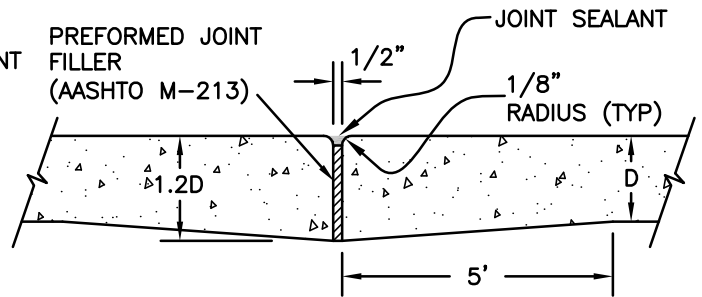

THICKENED EDGE ISOLATION JOINT

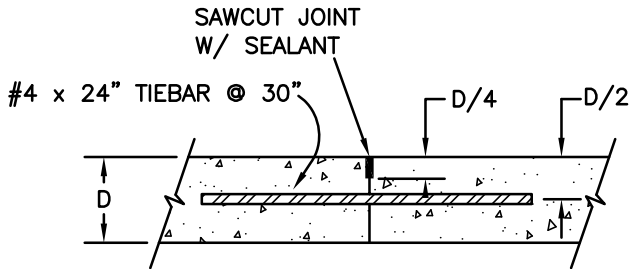

EMERGENCY CONSTRUCTION JOINT

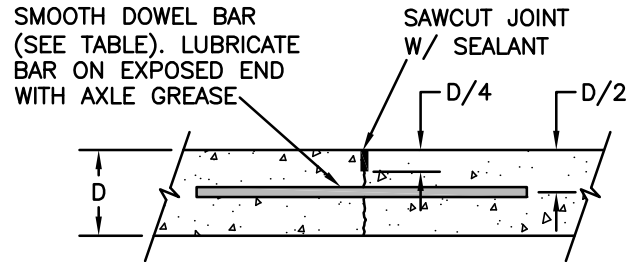

PLANNED CONSTRUCTION JOINT

NOTES

1. ALL EXPANSION AND ISOLATION JOINTS SHALL BE SEALED PER DETAILS ON PAGE C-28.
2. SEE PAGE C-30 FOR LONGITUDINAL JOINT DETAILS.
3. ALL HANDTOOLED JOINTS SHALL BE FINISHED WITH A 1/4" OR SMALLER RADIUS.
4. SEE SECTION 705.01 OF THE STANDARD SPECIFICATIONS FOR ROAD AND BRIDGE CONSTRUCTION FOR APPROVED JOINT SEALANTS.
5. PLACE RUBBER O-RING BETWEEN DOWEL BAR AND EXPANSION CAP

DOWEL SIZE FOR JOINTED REINFORCED PAVEMENTS AND CONSTRUCTION JOINTS		
SLAB DEPTH(D) INCHES	DOWEL DIAMETER INCHES	TOTAL DOWEL LENGTH INCHES
6.0 to 6.9	3/4	16
7.0 to 8.0	1	16

ALL DOWELS SPACED AT 12" CENTERS

JOINT DETAILS FOR CONCRETE PAVEMENT

DEPARTMENT OF PUBLIC WORKS AND PLANNING
ENGINEERING DIVISION
CITY OF GRAND JUNCTION, COLORADO

STANDARD CONCRETE
DETAIL

APPROVED: DN
REVISED: JAN. 2009
DRAWN: TLT

PAGE
C-29

MCCLAIN CITY STANDARD DRAWING DETAIL 200808-10-Concrete Details, Aug. C-30 (REV. 1-2009), 3/12/2009 8:02:35 AM

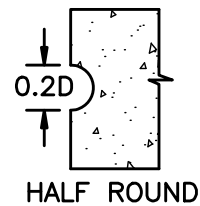
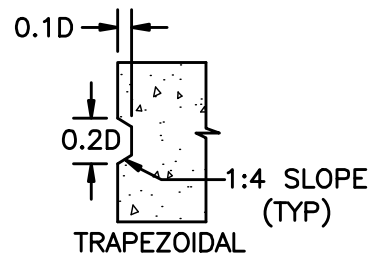
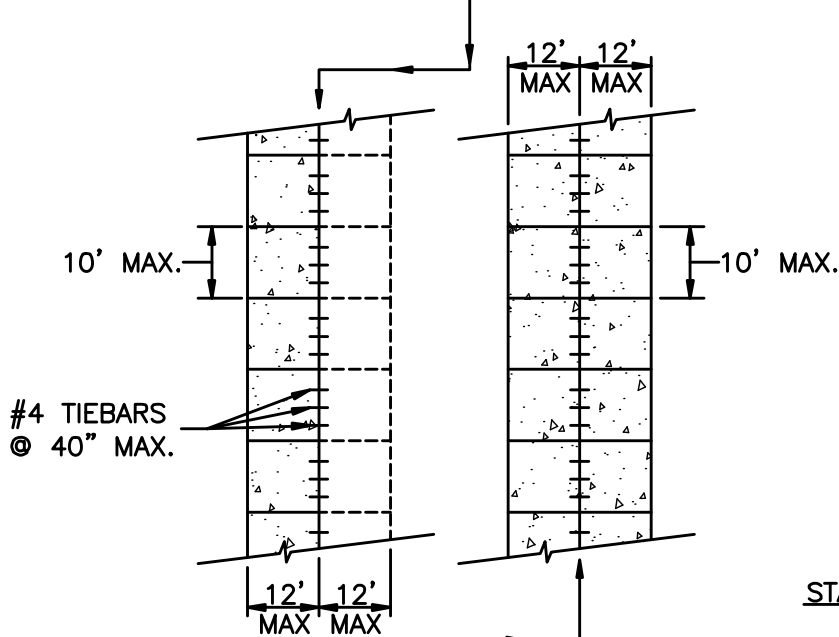
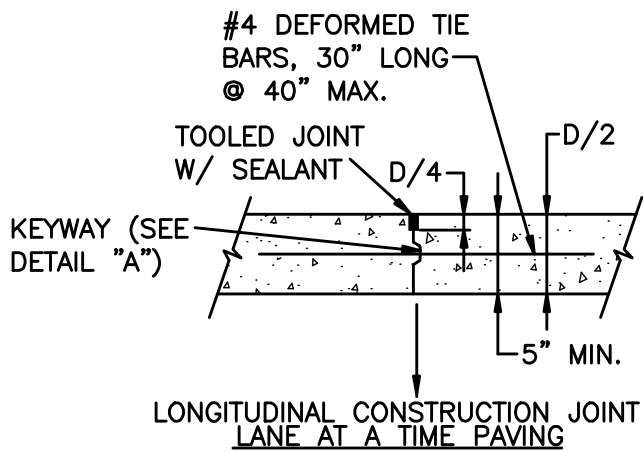

STANDARD KEYWAY DIMENSIONS DETAIL "A"

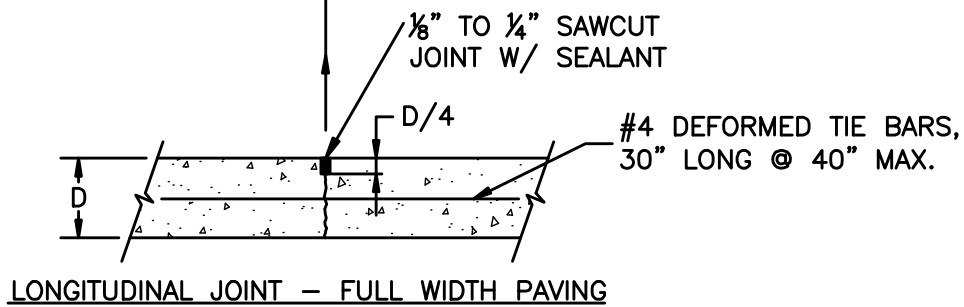

LONGITUDINAL JOINTS FOR CONCRETE PAVEMENT

DEPARTMENT OF PUBLIC WORKS AND PLANNING
ENGINEERING DIVISION
CITY OF GRAND JUNCTION, COLORADO

STANDARD CONCRETE
DETAIL

APPROVED: DN
REVISED: JAN. 2009
DRAWN: TLT

PAGE
C-30

N:\Cadd\CITY STANDARDS\STANDARD DRAWING DETAILS\2008 October Revisions\2008-10-Concrete Details.dwg, C-31 (REV 1-2009), 2/2/2009 7:56:39 AM

FRONT OF MAIL BOX @ BACK OF WALK
OR 1' BACK OF CURB WHERE SIDEWALK
IS DETACHED

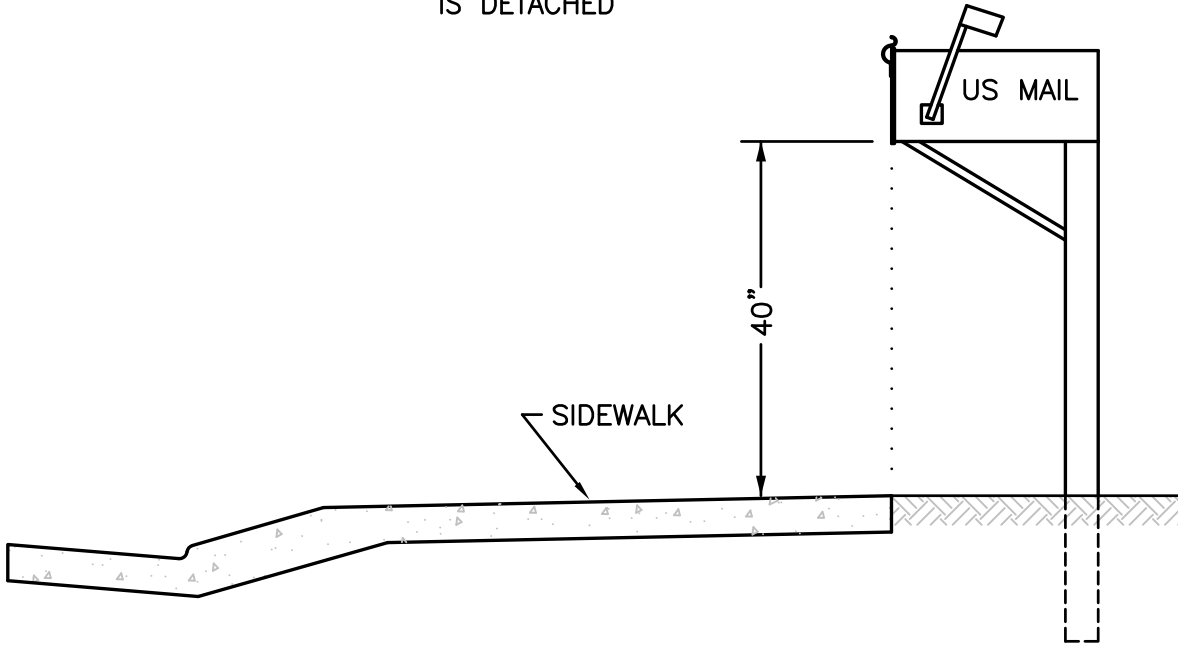

NOTE: THE LOCATION OF CENTRALIZED BOX UNITS
(CBU) SHALL BE APPROVED BY THE U.S. POSTAL
SERVICE (970)244-3480. SEE SECTION 8.3 OF THE
CITY'S T.E.D.S. MANUAL FOR MINIMUM REQUIREMENTS.

MAIL BOX INSTALLATION

DEPARTMENT OF PUBLIC WORKS AND PLANNING
ENGINEERING DIVISION
CITY OF GRAND JUNCTION, COLORADO

STANDARD CONCRETE
DETAIL

APPROVED: DN
REV: JAN. 2009
DRAWN: DPW

PAGE
C-31

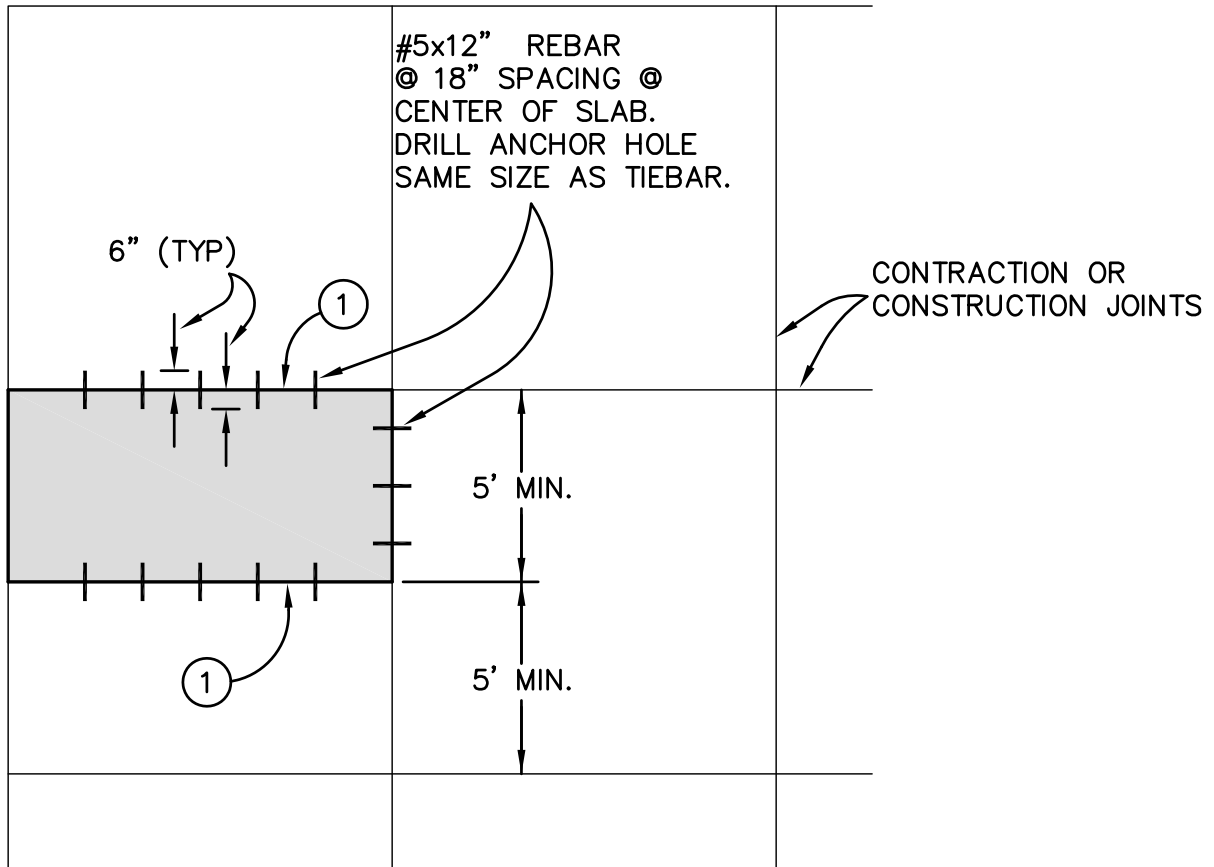

- 1 CONCRETE SHALL BE REMOVED TO A SAWCUT LINE OR TO AN EXISTING JOINT.
- 2 ALL JOINTS SHALL BE CUT THROUGH 90 PERCENT OF CONCRETE THICKNESS PRIOR TO CONCRETE REMOVAL.
- 3 CONCRETE EDGES OR SURFACES THAT ARE BROKEN, CHIPPED, CRACKED OR OTHERWISE DAMAGED DURING PAVEMENT REMOVAL SHALL BE CUT AND REMOVED AS DIRECTED BY THE CONSTRUCTION INSPECTOR.
- 4 ALL PATCHES SHALL BE MADE WITH CDOT CLASS B CONCRETE. SAME THICKNESS AS ADJACENT PAVEMENT.

PATCH IN CONCRETE PAVEMENT

DEPARTMENT OF PUBLIC WORKS AND PLANNING
ENGINEERING DIVISION
CITY OF GRAND JUNCTION, COLORADO

STANDARD CONCRETE
DETAIL

APPROVED: DN
REV: JULY 2005
DRAWN: GM

PAGE
C-32

**MINIMUM CORNER CLEARANCE (FT)
MEASURED FROM FLOWLINE TO NEAR EDGE OF DRIVEWAY**

STREET CLASSIFICATION	CLEARANCE FROM SIGNALIZED INTERSECTION	CLEARANCE FROM UNSIGNALIZED INTERSECTION	SINGLE FAMILY RESIDENTIAL DRIVEWAYS
LOCAL	50'	150'	50'
COLLECTOR	150'	150'	100'
MINOR ARTERIAL	150'*	300'*	100'*
MAJOR ARTERIAL	300'*	300'*	150'*

*MAY BE RESTRICTED TO RIGHT-IN, RIGHT-OUT ONLY ACCESS, SINGLE FAMILY ACCESS TO ARTERIAL STREETS IS NOT ACCEPTABLE PRACTICE AND WILL BE PERMITTED ONLY IN EXTREME HARDSHIP CASES.

STREET CLASSIFICATION	DRIVEWAY SPACING (S)	DRIVEWAY WIDTH (W)	OFFSET (OS)
SINGLE FAMILY RESIDENTIAL	10' MIN.	12' MIN. 33' MAX.	
LOCAL COMMERCIAL AND INDUSTRIAL	50' MIN.	28' MIN. 40' MAX.	50' MIN.*
COLLECTOR	150' MIN.	28' MIN. 40' MAX.	150' MIN.*
ARTERIAL	300' MIN.	28' MIN. 40' MAX.	300' MIN.*

* GREATER OFFSETS MAY BE REQUIRED FOR LEFT TURN STORAGE LANES.

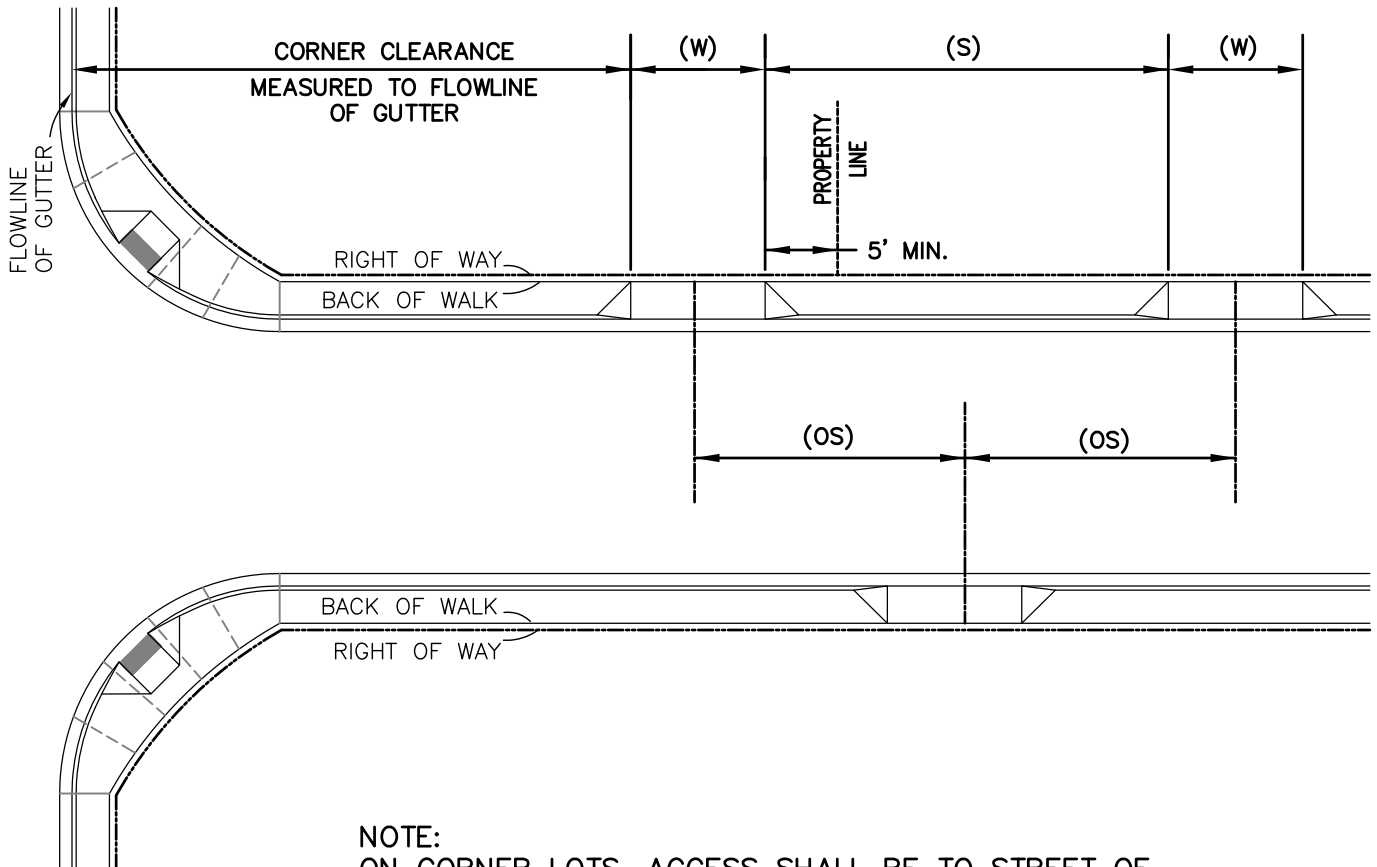

NOTE:
ON CORNER LOTS, ACCESS SHALL BE TO STREET OF
LOWEST FUNCTIONAL CLASSIFICATION.

MINIMUM DRIVEWAY SPACING AND CORNER CLEARANCE

DEPARTMENT OF PUBLIC WORKS AND PLANNING
ENGINEERING DIVISION
CITY OF GRAND JUNCTION, COLORADO

STANDARD CONCRETE
DETAIL

APPROVED: DN
REVISED: FEB. 2007
DRAWN: TLT

PAGE
C-33

MAXIMUM DRIVEWAY APPROACH GRADES

ROADWAY CLASS	DRIVEWAY TYPE			
	RESIDENTIAL		OTHER THAN RESIDENTIAL	
	S_1	S_2	S_1	S_2
OTHER THAN RESIDENTIAL	8%	4%	6%	4%
RESIDENTIAL	14%	6%	6%	4%

NOTE: STEEPER DRIVEWAY APPROACH MAY BE APPROVED WHERE REQUIRED TO MATCH EXISTING CONDITIONS.

MINIMUM LENGTH OF APPROACH @ MAXIMUM GRADE

ROADWAY CLASS	DRIVEWAY TYPE	
	RESIDENTIAL	OTHER THAN RESIDENTIAL
	L	L
OTHER THAN RESIDENTIAL	16.5'	33'
RESIDENTIAL	13'	26'

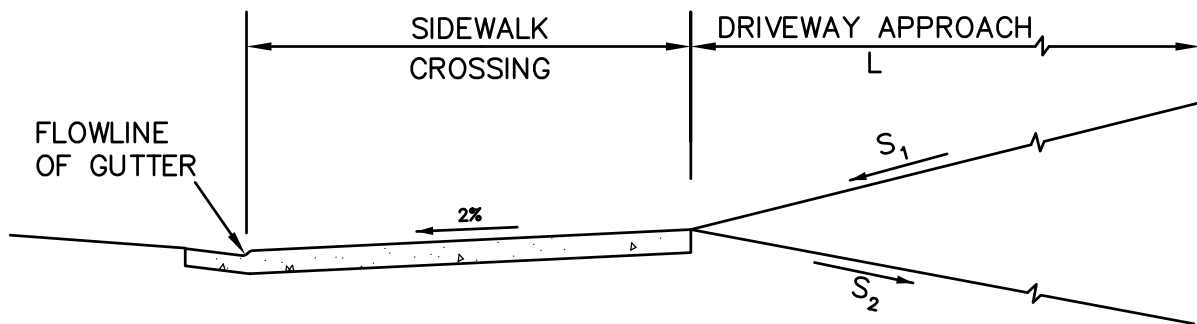

DRIVEWAY APPROACH GRADES

DRIVEWAY APPROACH GRADES

DEPARTMENT OF PUBLIC WORKS AND PLANNING
ENGINEERING DIVISION
CITY OF GRAND JUNCTION, COLORADO

STANDARD CONCRETE
DETAIL

APPROVED: DN
REV: FEB. 2005
DRAWN: JCS

PAGE
C-34

N:\Cadd\CITY STANDARDS\STANDARD DRAWING DETAILS\2008 October Revisions\2008-10-Concrete Details.dwg, C-35 (REV 3-2007), 3/2/2009 1:26:31 PM

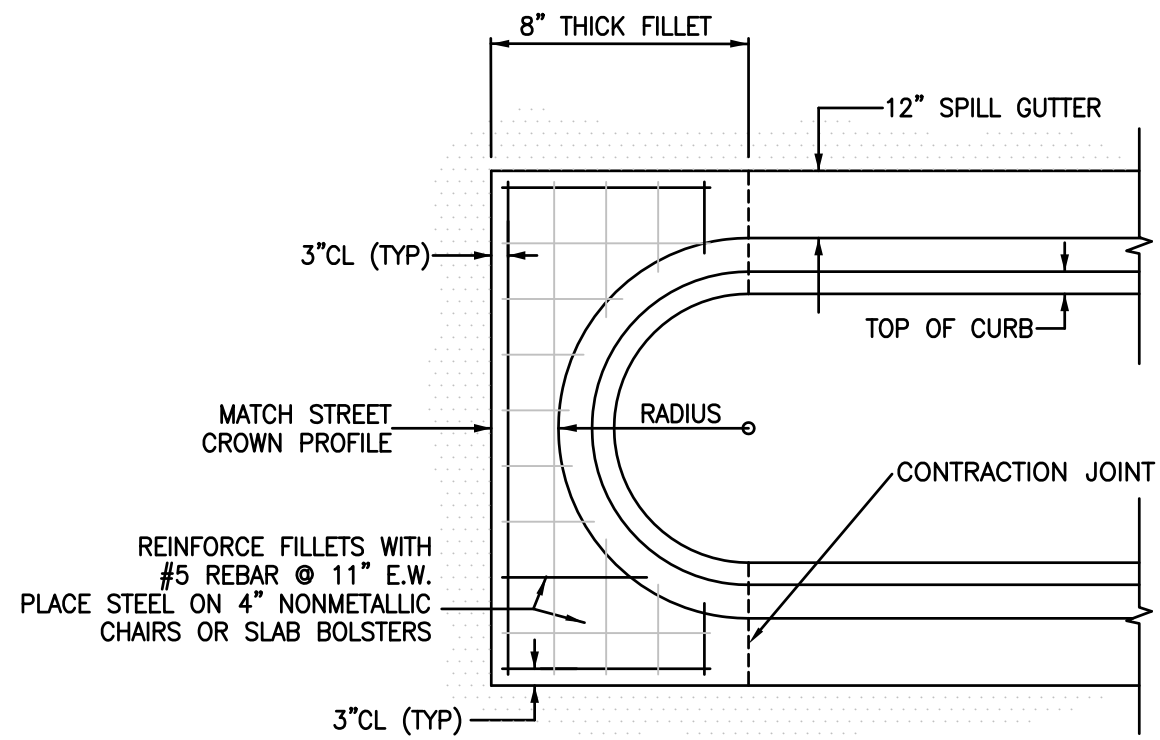
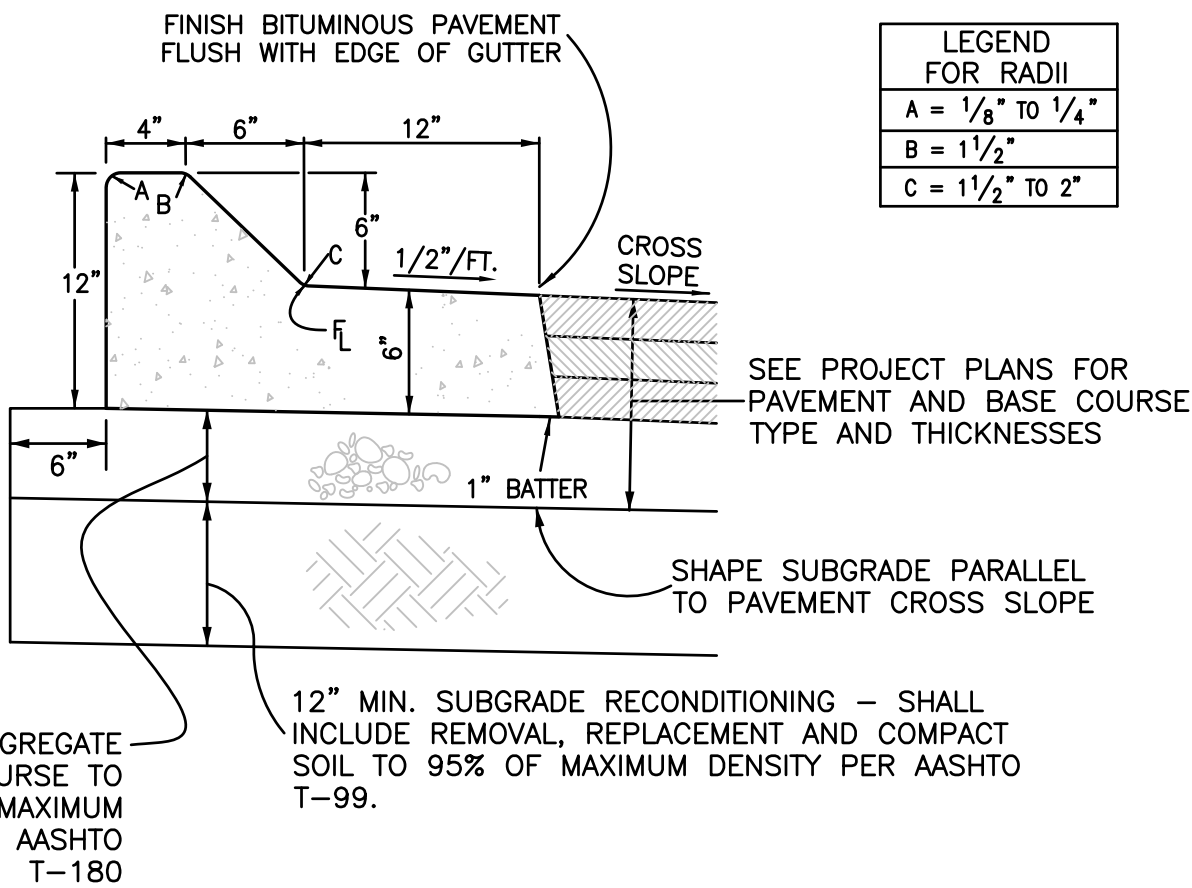

MEDIAN CURB DETAILS

DEPARTMENT OF PUBLIC WORKS AND PLANNING ENGINEERING DIVISION CITY OF GRAND JUNCTION, COLORADO	STANDARD CONCRETE DETAIL	APPROVED: <u>DN</u> REV: <u>FEB. 2006</u> DRAWN: <u>GM</u>	PAGE C-35
---	-----------------------------	--	--------------

- D-01 General Notes
- D-02 Inlet Curb Box Detail
- D-03 Standard Storm Sewer Manhole
- D-04 Standard Manhole Ring and Cover
- D-05 Approved Storm Drain Inlets
- D-06 Storm Drain Inlet with Drive Over Curb Opening
- D-07 Storm Drain Inlet with Vertical Curb Opening
- D-08 Double Storm Drain Inlet with Vertical Curb Opening
- D-09 Triple Storm Drain Inlet with Vertical Curb Opening
- D-10 Large Area Inlet
- D-11 Small Area Inlet
- D-12 Connection to Existing Pipe, Manhole or Inlet Box
- D-13 Drain Trough for Sidewalk Crossing
- D-14 Frame and Cover for Sidewalk Drain Through
- D-15 Irrigation Manhole with Precast Base

TABLE OF CONTENTS – STORM DRAIN DETAILS

DEPARTMENT OF PUBLIC WORKS AND PLANNING
ENGINEERING DIVISION
CITY OF GRAND JUNCTION, COLORADO

STANDARD STORM DRAIN
DETAILS

APPROVED: DN
DATE: FEB 2005
DRAWN: DPW

PAGE
D-00

N:\cadd\CIT\STANDARD\STANDARD DRAWINGS\DETAILS\2007-Storm Sewer Details.DWG, D-01, 5/29/2007 4:33:56 PM

1. BACKFILL AROUND MANHOLES, INLET BOXES, AND OTHER STRUCTURES SHALL BE PLACED IN 8" LIFTS AND COMPACTED TO 95% AASHTO T-180.
2. ALL PORTLAND CEMENT CONCRETE SHALL BE COLORADO DEPARTMENT OF TRANSPORTATION CLASS "B". (SECTION 601.02).
3. ANY EXISTING PAVEMENT NOT DESIGNATED FOR REMOVAL WHICH IS DAMAGED BY CONSTRUCTION SHALL BE REPLACED IN-KIND BY CONTRACTOR.
4. ALL CONCRETE WORK WITHIN PUBLIC RIGHT-OF-WAY SHALL BE PERFORMED BY A LICENSED CITY CONTRACTOR.
5. SEE APPROVED CONSTRUCTION DRAWINGS FOR ALL LOCATIONS, GRADES AND ELEVATIONS OF ALL DRAINAGE IMPROVEMENTS.
6. MANHOLE RING AND COVER AND INLET GRATE AND FRAME SHALL BE ADJUSTED TO FINISHED GRADE USING NON-SHRINK GROUT AND PRE-CAST CONCRETE GRADE RINGS OR WITH THE "WHIRLY GIG" METHOD. GROUT THICKNESS SHALL NOT EXCEED 2 INCHES. GROUT SHALL BE PLACED UNDER THE CAST IRON RING OR FRAME. NO GROUT SHALL BE PLACED BETWEEN THE CONCRETE GRADE RINGS. STEEL GRADE ADJUSTMENT RINGS MAY BE USED FOR ADJUSTMENT OF MANHOLE COVERS ONLY WHEN STREETS ARE OVERLAID.
7. SEE THE CITY OF GRAND JUNCTION STORMWATER MANAGEMENT MANUAL FOR STORMWATER DESIGN CRITERIA.
8. ALL WORK SHALL BE IN ACCORDANCE WITH APPROVED PLANS, STANDARD STORM DRAIN DETAILS AND THE STANDARD SPECIFICATIONS FOR CONSTRUCTION OF UNDERGROUND UTILITIES.
9. STORM DRAIN INLET BOXES MAY BE MADE FROM STACKABLE PRECAST BOX SECTIONS WITH TONGUE AND GROOVE JOINTS AND FLEXIBLE SEALANT BETWEEN SECTIONS. THE TOP SECTION OF THE INLET BOX SHALL HAVE A GROOVE-LESS FLAT SURFACE TO SUPPORT THE INLET FRAME AND GRATE.

GENERAL NOTES

DEPARTMENT OF PUBLIC WORKS AND PLANNING
ENGINEERING DIVISION
CITY OF GRAND JUNCTION, COLORADO

STANDARD STORM DRAIN
DETAIL

APPROVED: DN
REV: FEB. 2005
DRAWN: DFW

PAGE
D-01

N:\cadd\CIT - STANDARD\STANDARD DRAWINGS DETAILS\2007 - Storm Sewer Details.DWG, D-02, 5/29/2007 4:34:15 PM

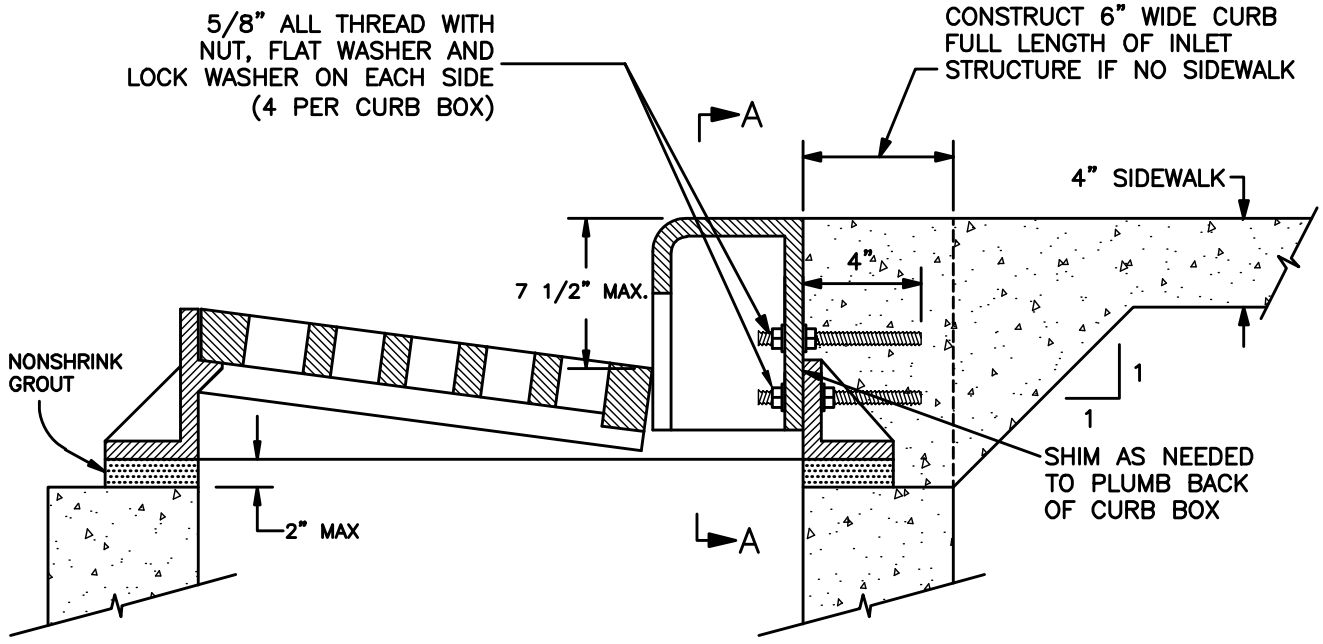

SIDE VIEW
N.T.S.

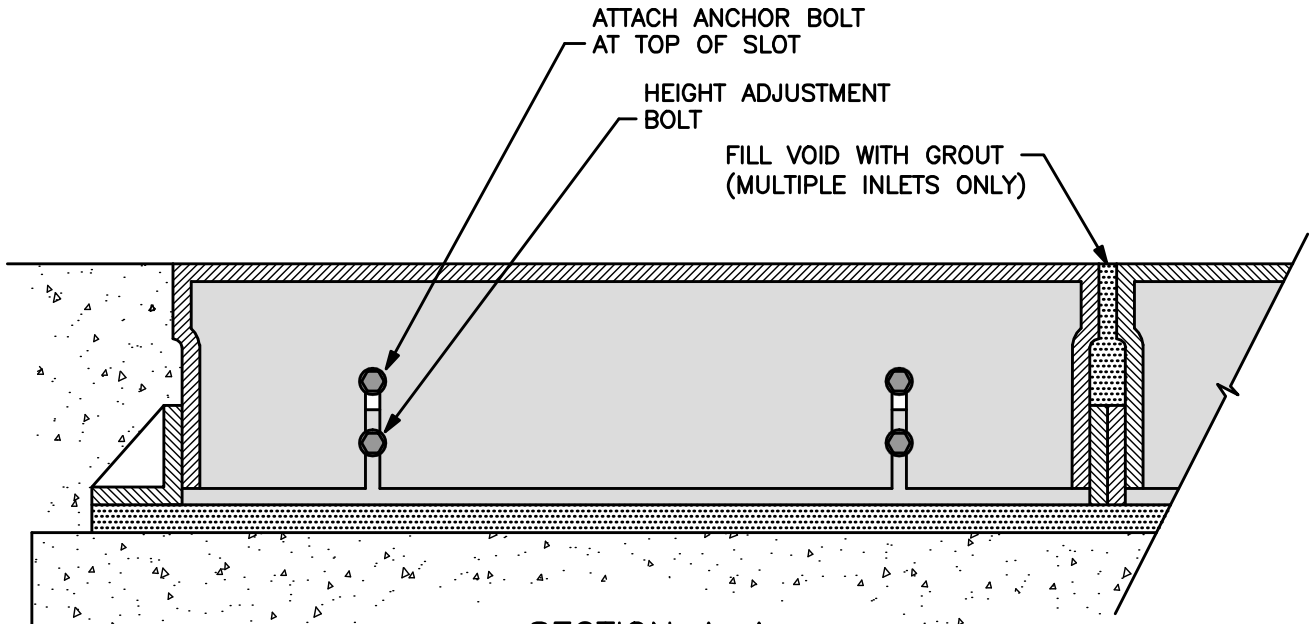

SECTION A-A
N.T.S.

INLET CURB BOX DETAIL

DEPARTMENT OF PUBLIC WORKS AND PLANNING
ENGINEERING DIVISION
CITY OF GRAND JUNCTION, COLORADO

STANDARD STORM DRAIN
DETAIL

APPROVED: DN
DATE: JULY 2005
DRAWN: DM

PAGE
D-02

N:\cadd\CIT\STANDARD\STANDARD DRAWING DETAILS\2007-Storm Sewer Details.DWG, D-03 (REV 01-07), 5/29/2007 4:34:23 PM

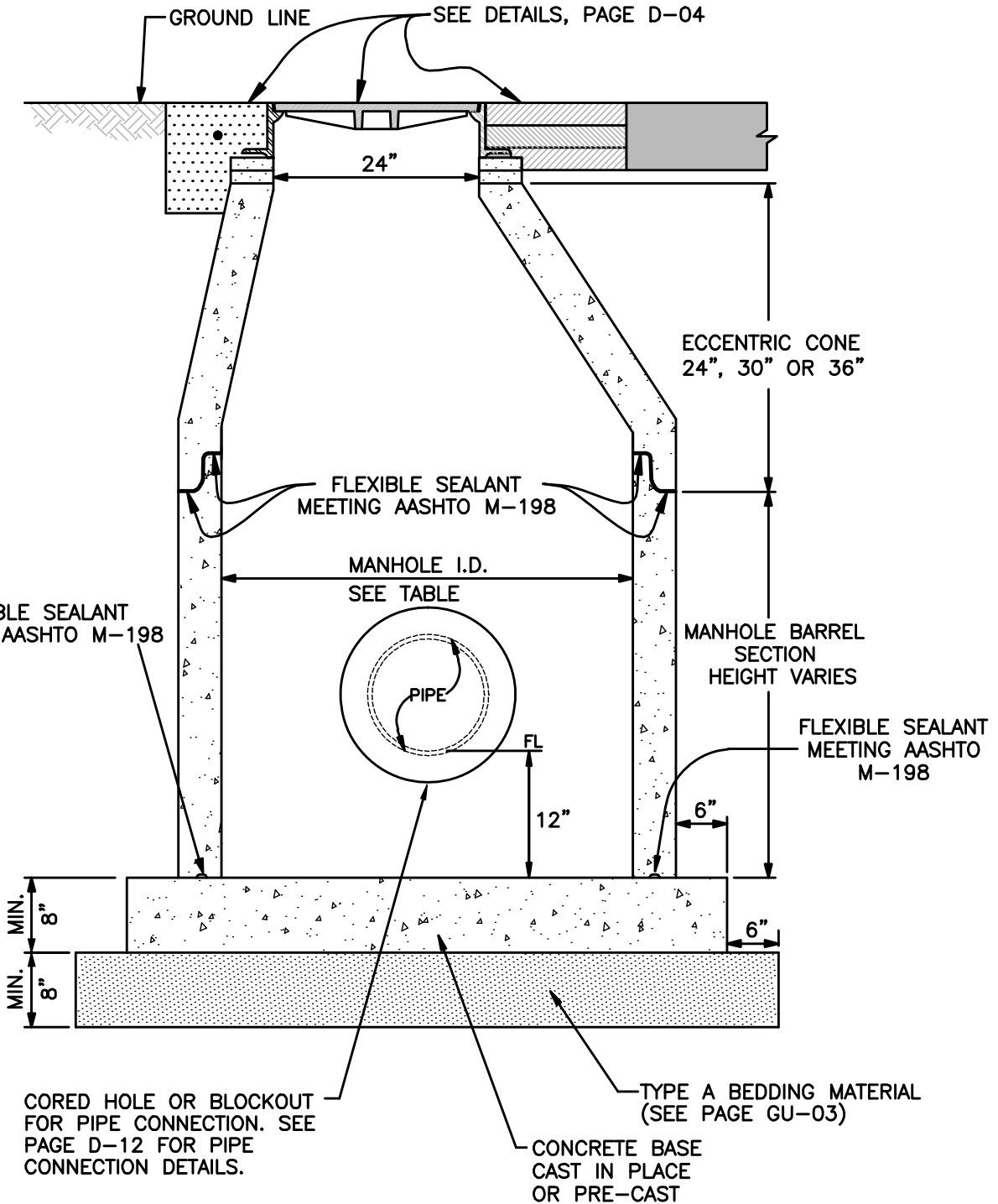

PIPE DIAMETER	MANHOLE I.D.
18" OR LESS	48"
21" - 30"	60"
36"	72"
42" - 48"	90"

ALL PRECAST MANHOLE SECTIONS SHALL CONFORM TO ASTM C-478 OR AASHTO M-199.

NO STEPS REQUIRED IN STORM SEWER MANHOLES.

STANDARD STORM SEWER MANHOLE

DEPARTMENT OF PUBLIC WORKS AND PLANNING
ENGINEERING DIVISION
CITY OF GRAND JUNCTION, COLORADO

STANDARD STORM DRAIN
DETAIL

APPROVED: DN
REVISED: FEB 2001
DRAWN: TLT

PAGE
D-03

ADJUST MANHOLE RING AND COVER TO MATCH SLOPE OF PAVEMENT. TOP OF M.H. LID SHALL BE FLUSH WITH OR NO MORE THAN 1/8" BELOW TOP OF ASPHALT

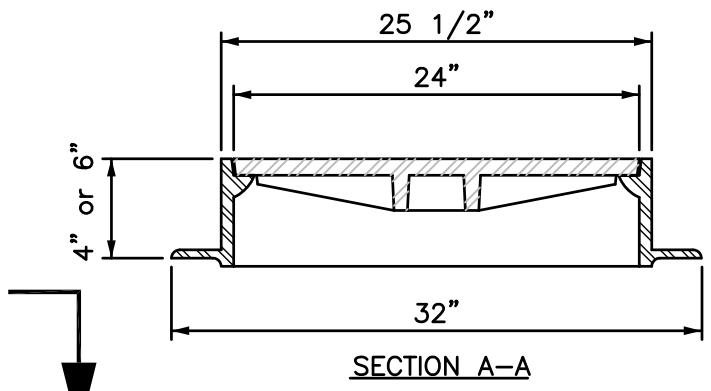
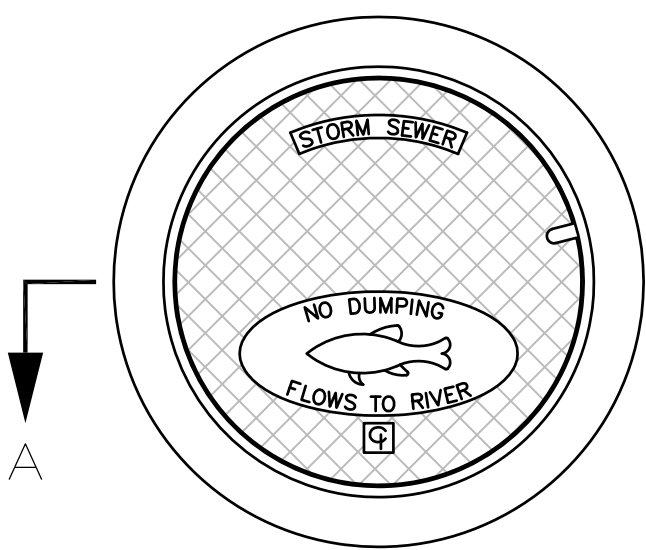
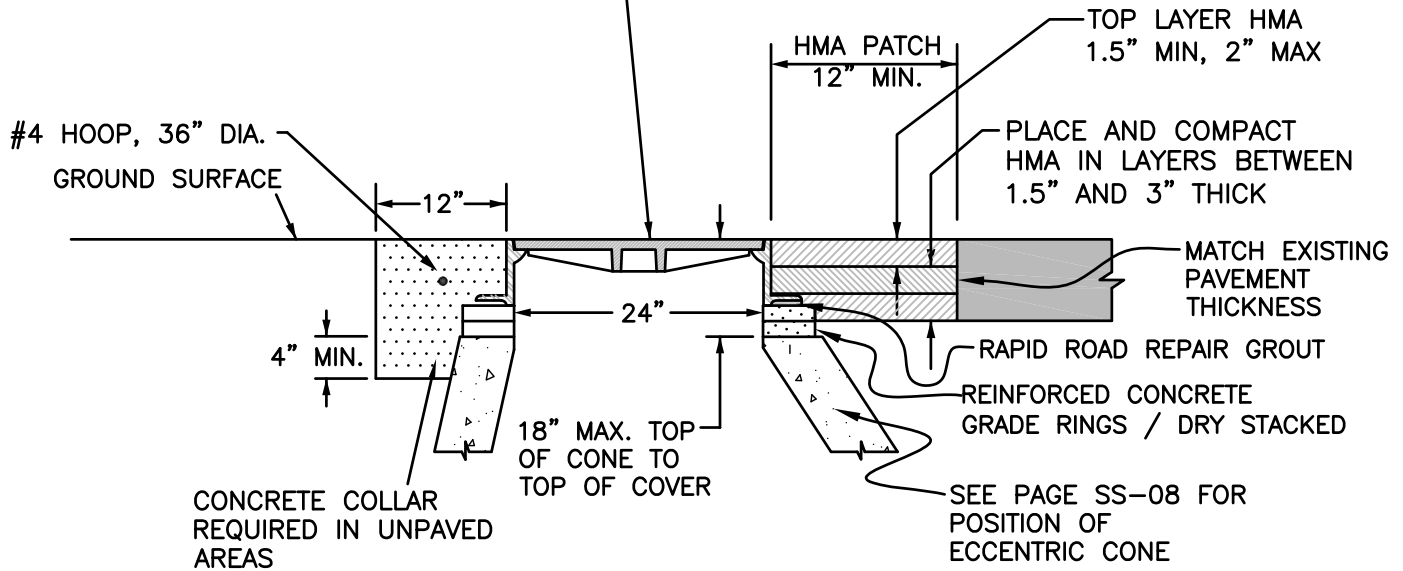

STANDARD M.H. RING & COVER
(CASTINGS INC. 24-B-CI (FISH))

NOTE:
WHERE A GRATE TYPE COVER IS
REQUIRED USE CASTINGS
MH-24-GBP CI

STANDARD MANHOLE RING AND COVER

DEPARTMENT OF PUBLIC WORKS AND PLANNING
ENGINEERING DIVISION
CITY OF GRAND JUNCTION, COLORADO

STANDARD STORM DRAIN
DETAIL

APPROVED: SBG
REVISED: JUNE 2010
DRAWN: JAF

PAGE
D-04

APPROVED STORM DRAIN INLETS			
TYPE	GRATE AND FRAME DESIGNATION	CASTINGS GRATE TYPE	BOX DIM. INSIDE
SINGLE GRATE WITH CURB VERTICAL OPENING	CASTINGS IFG-3246-() C.I.	R,L,V,D	24 X 36"
DOUBLE GRATE WITH CURB OPENING	CASTINGS IFG-3246-() C.I. DOUBLE	R,L,V,D	24" X 73"
TRIPLE GRATE WITH CURB OPENING	CASTINGS IFG-3246-() C.I. TRIPLE	R,L,V,D	24" X 110"
AREA INLET	CASTINGS FG-1927-CI	FLAT OR CONCAVE	20" X 30"
	CASTINGS NO. 13 UR16		24" x 36"
INLET WITH DRIVE OVER CURB BOX	CASTINGS IFG-3246() DOC. I:	R,L,V,D	24 X 36"
STANDARD MANHOLE GRATE	CASTINGS MH-24-GBP CI		
C.D.O.T. TYPE R	SEE STANDARD M-604-12		
C.D.O.T. TYPE 13	SEE STANDARD M-604-13		

SHOW GRATE TYPE WHERE INDICATED BY ()

NOTE: USE TYPE R OR TYPE D GRATE WHERE INLET IS LOCATED IN SUMP CONDITION. USE TYPE V OR TYPE L GRATE WHERE GUTTER FLOW IS FROM ONE DIRECTION ONLY.

GRATES AND FRAMES FROM OTHER FOUNDARIES MAY BE USED WHEN APPROVED BY THE CITY ENGINEER.

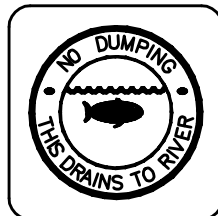

PLACARD TO BE PLACED ON EACH STORM SEWER OPENING INSTALLED WITHIN THE SYSTEM SERVED BY THE CITY OF GRAND JUNCTION OBTAIN FROM THE CITY OF GRAND JUNCTION INSPECTION STAFF © (970)244-1577

APPROVED STORM DRAIN INLETS

DEPARTMENT OF PUBLIC WORKS AND PLANNING ENGINEERING DIVISION CITY OF GRAND JUNCTION, COLORADO	STANDARD STORM DRAIN DETAIL	APPROVED: <u>DN</u> REV: <u>JULY 2005</u> DRAWN: <u>DM</u>	PAGE D-05
---	--------------------------------	--	--------------

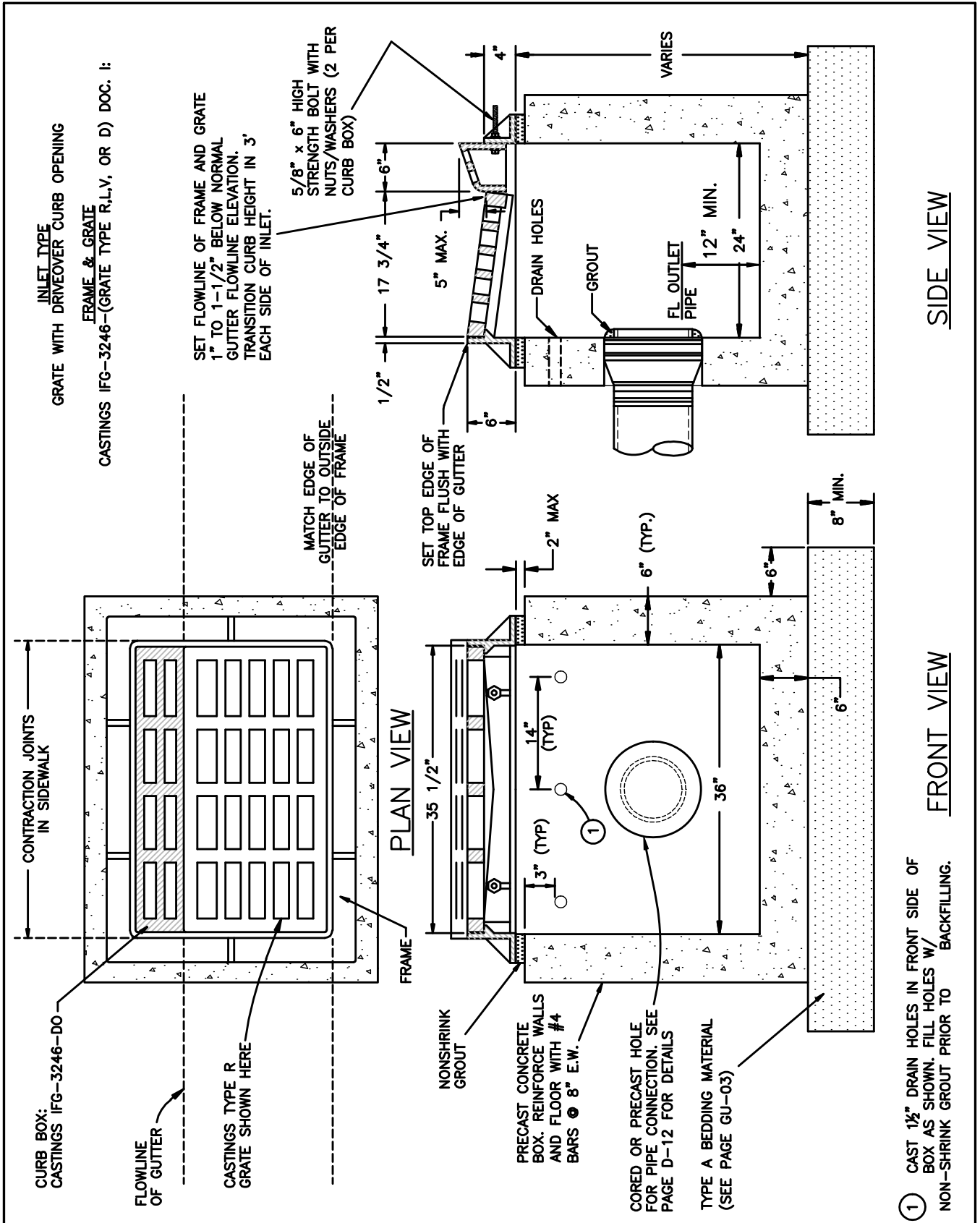

STORM DRAIN INLET WITH DRIVE OVER CURB OPENING

DEPARTMENT OF PUBLIC WORKS AND PLANNING
 ENGINEERING DIVISION
 CITY OF GRAND JUNCTION, COLORADO

STANDARD STORM DRAIN
 DETAIL

APPROVED: DN
 DATE: APRIL 2007
 DRAWN: CM

PAGE
 D-06

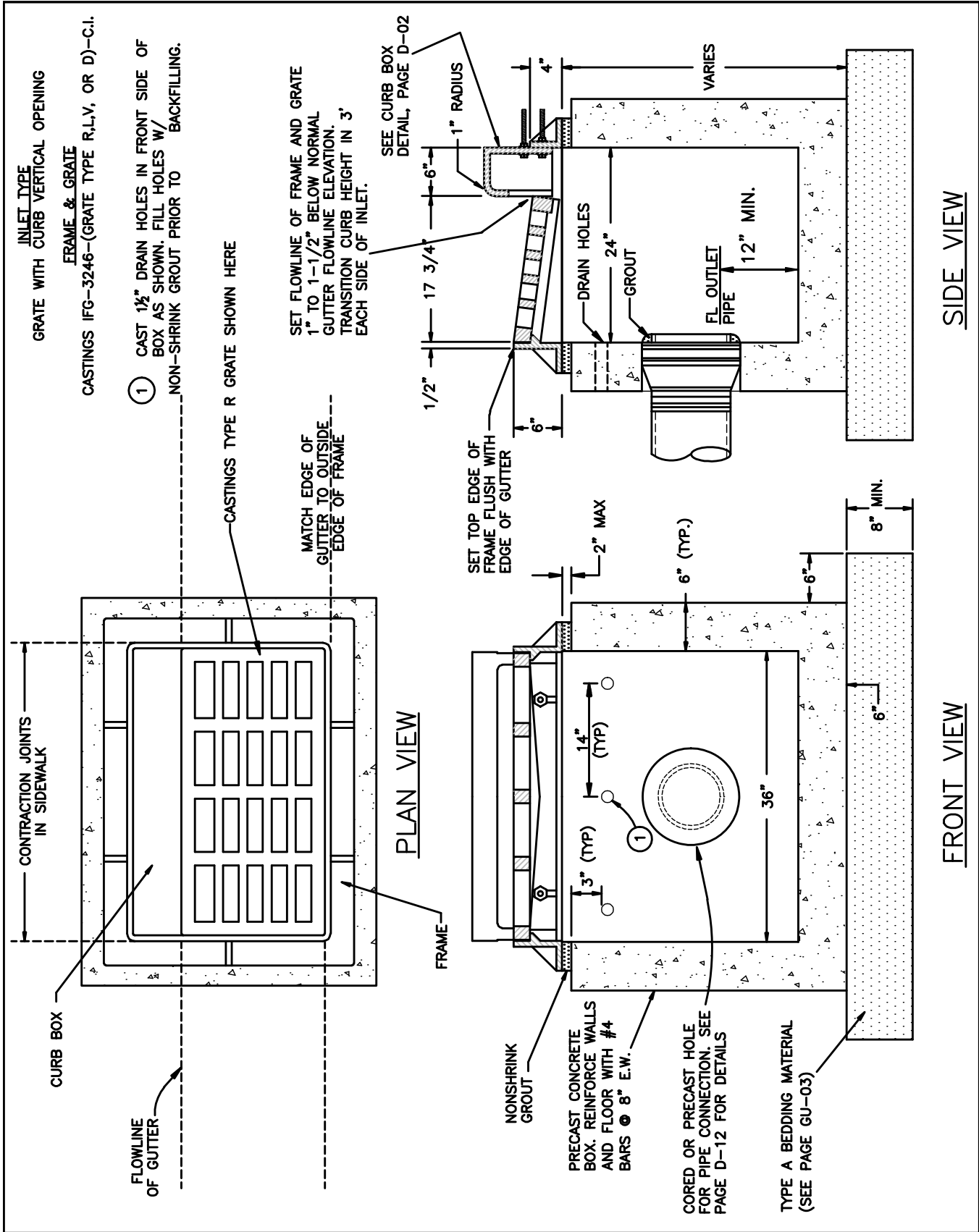

STORM DRAIN INLET WITH VERTICAL CURB OPENING

DEPARTMENT OF PUBLIC WORKS AND PLANNING
 ENGINEERING DIVISION
 CITY OF GRAND JUNCTION, COLORADO

STANDARD STORM DRAIN
 DETAIL

APPROVED: DN
 DATE: APRIL 2007
 DRAWN: CM

PAGE
 D-07

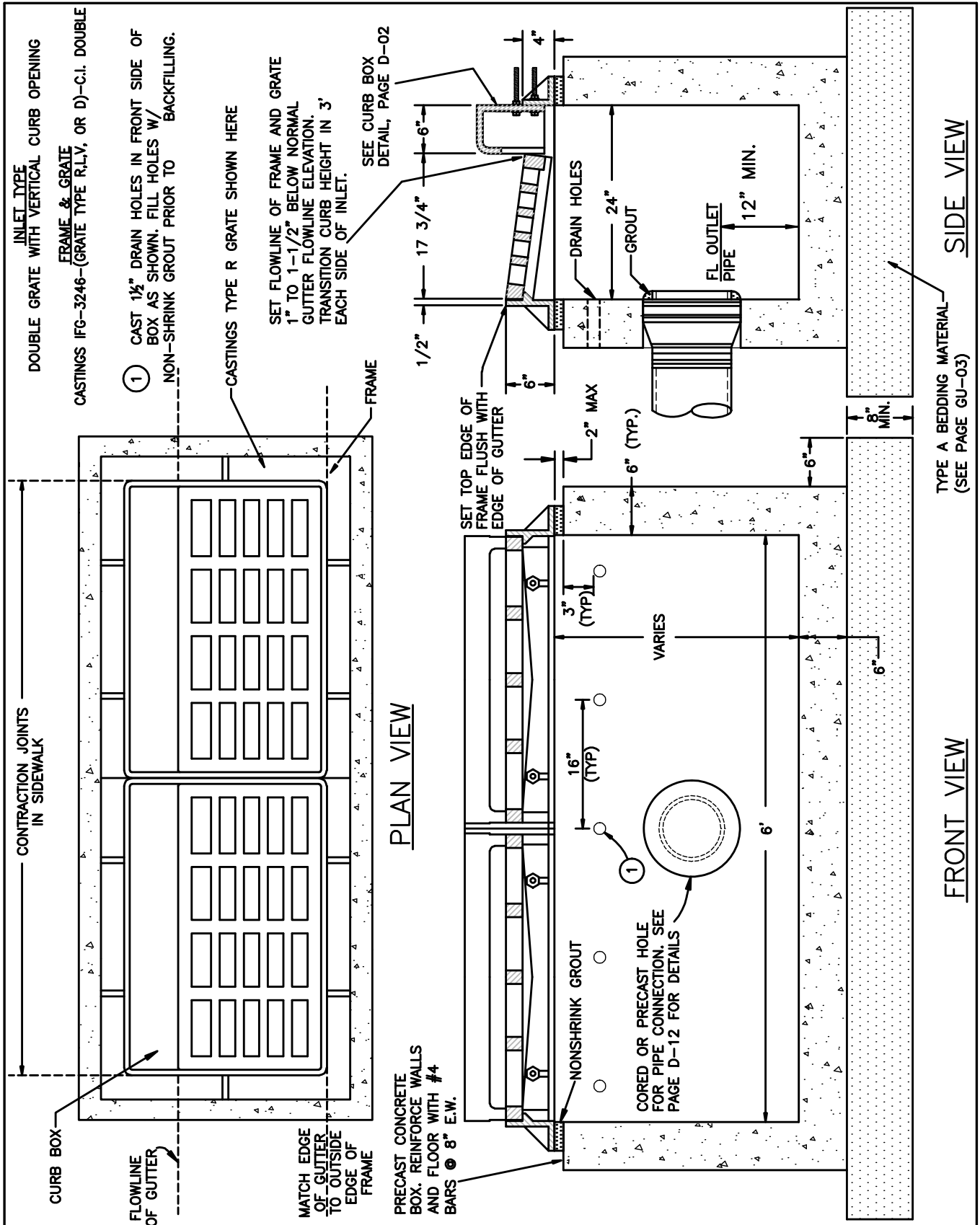

DOUBLE STORM DRAIN INLET WITH VERTICAL CURB OPENING

DEPARTMENT OF PUBLIC WORKS AND PLANNING
ENGINEERING DIVISION
CITY OF GRAND JUNCTION, COLORADO

STANDARD STORM DRAIN
DETAIL

APPROVED: DN
DATE: APRIL 2007
DRAWN: CM

PAGE
D-08

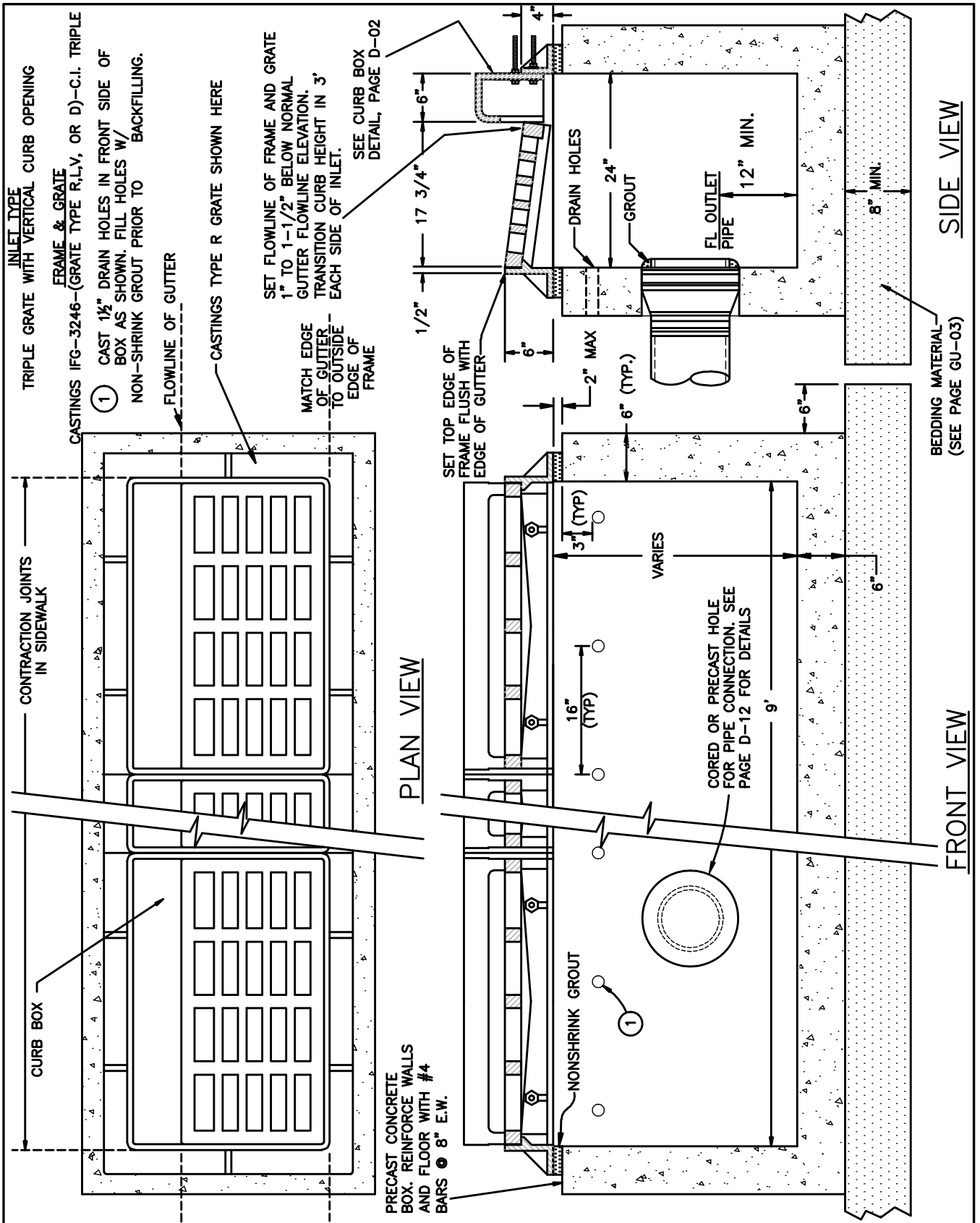

TRIPLE STORM DRAIN INLET WITH VERTICAL CURB OPENING

DEPARTMENT OF PUBLIC WORKS AND PLANNING
ENGINEERING DIVISION
CITY OF GRAND JUNCTION, COLORADO

STANDARD STORM DRAIN
DETAIL

APPROVED: DN
DATE: APRIL 2007
DRAWN: CM

PAGE
D-09

INLET TYPE
AREA INLET

FRAME & GRATE
CASTINGS NO. 13 OR 16

- ① CAST 1/2" DRAIN HOLES IN EACH SIDE OF BOX AS SHOWN. FILL HOLES W/ NON-SHRINK GROUT PRIOR TO BACKFILLING.

IN UNPAVED AREAS A 12"x12" CONCRETE COLLAR SHALL BE CAST AROUND THE INLET FRAME. SURFACE OF THE COLLAR SHALL SLOPE TO THE INLET GRATE.

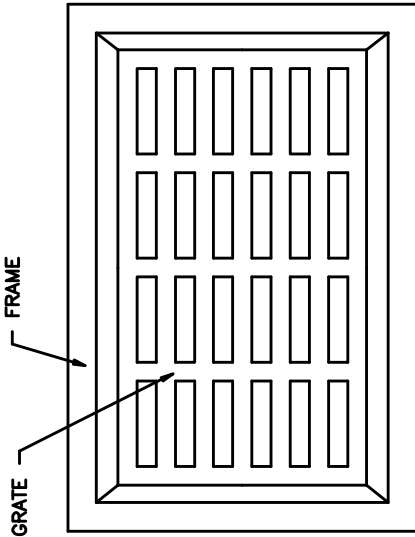

PLAN VIEW

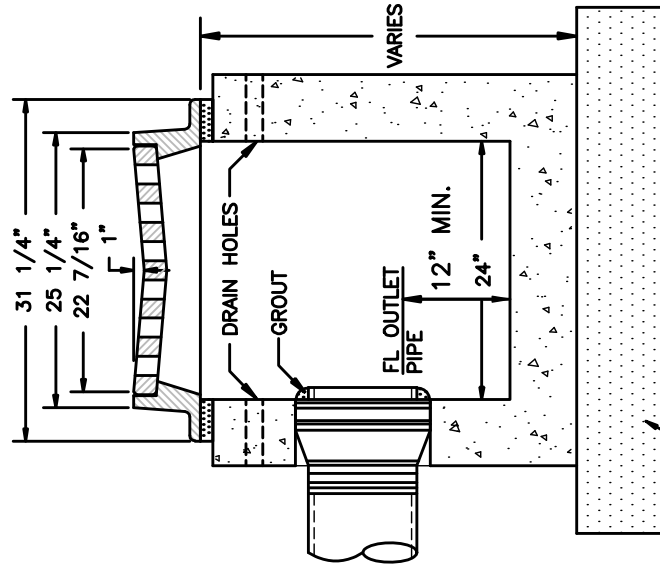

SIDE VIEW

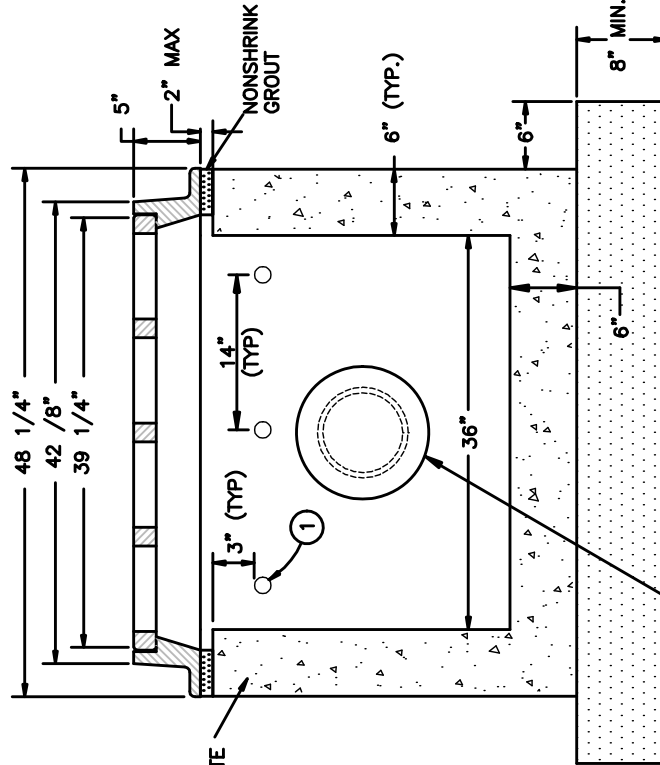

FRONT VIEW

CORED OR PRECAST HOLE FOR PIPE CONNECTION. SEE PAGE D-12 FOR DETAILS

BEDDING MATERIAL (SEE PAGE GU-05)

LARGE AREA INLET

DEPARTMENT OF PUBLIC WORKS AND PLANNING
ENGINEERING DIVISION
CITY OF GRAND JUNCTION, COLORADO

STANDARD STORM DRAIN
DETAIL

APPROVED: DN
REV: APRIL 2007
DRAWN: CM

PAGE
D-10

TYPE
AREA INLET
FRAME
CASTINGS FG-1927-CI

FLAT OR CONCAVE
GRATES AVAILABLE

① CAST 1½" DRAIN HOLES IN EACH SIDE OF BOX AS SHOWN. FILL HOLES W/ NON-SHRINK GROUT PRIOR TO BACKFILLING.

IN UNPAVED AREAS A 12"x12" CONCRETE COLLAR SHALL BE CAST AROUND THE INLET FRAME. SURFACE OF THE COLLAR SHALL SLOPE TO THE INLET GRATE.

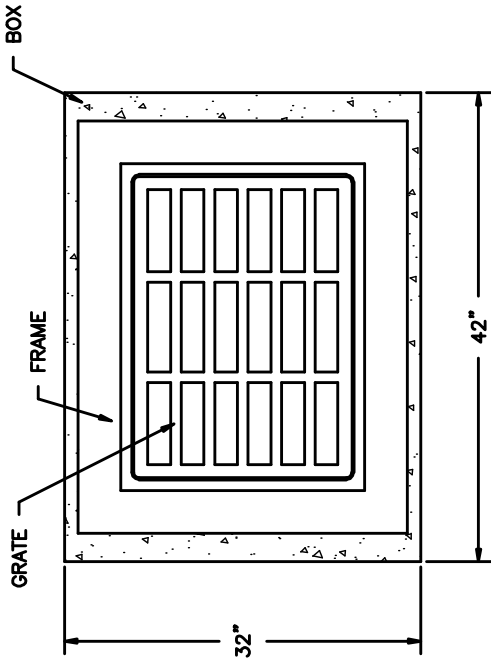

PLAN VIEW

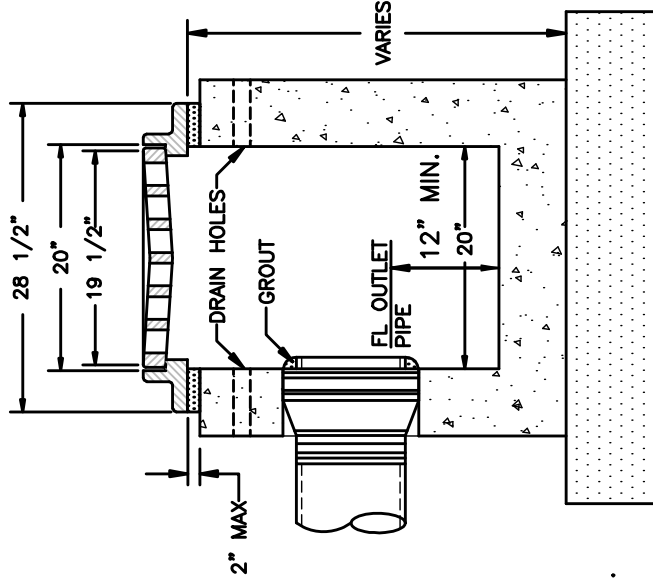

SIDE VIEW

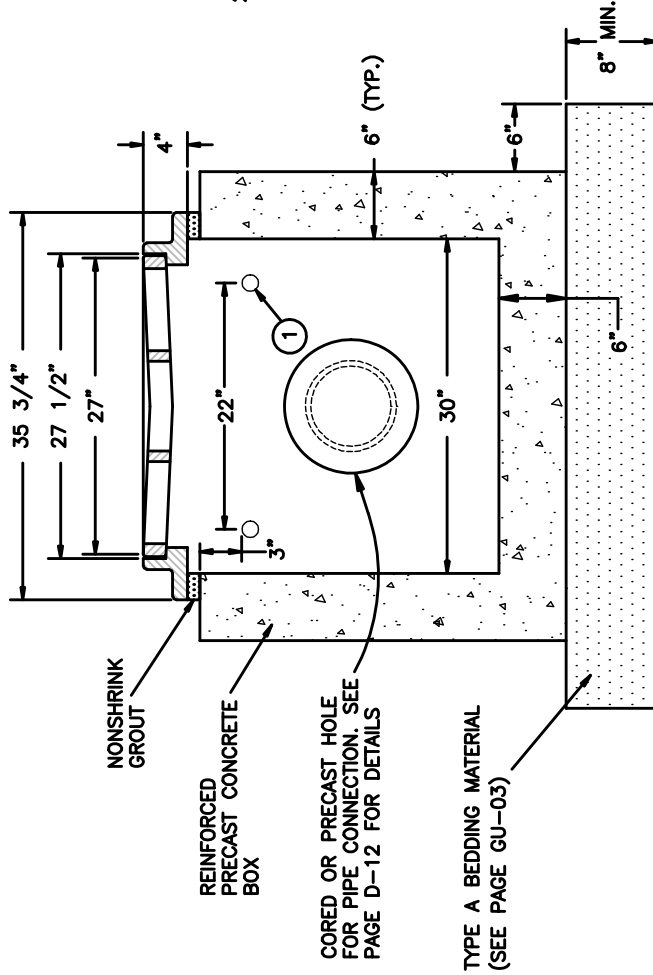

FRONT VIEW

SMALL AREA INLET

DEPARTMENT OF PUBLIC WORKS AND PLANNING
ENGINEERING DIVISION
CITY OF GRAND JUNCTION, COLORADO

STANDARD STORM DRAIN
DETAIL

APPROVED: DN
DATE: APRIL 2007
DRAWN: CM

PAGE
D-11

N:\cadd\CIT - STANDARD\STANDARD DRAWING DETAILS\2007 - Storm Sewer Details.DWG, D-12, 5/29/2007 4:42:13 PM

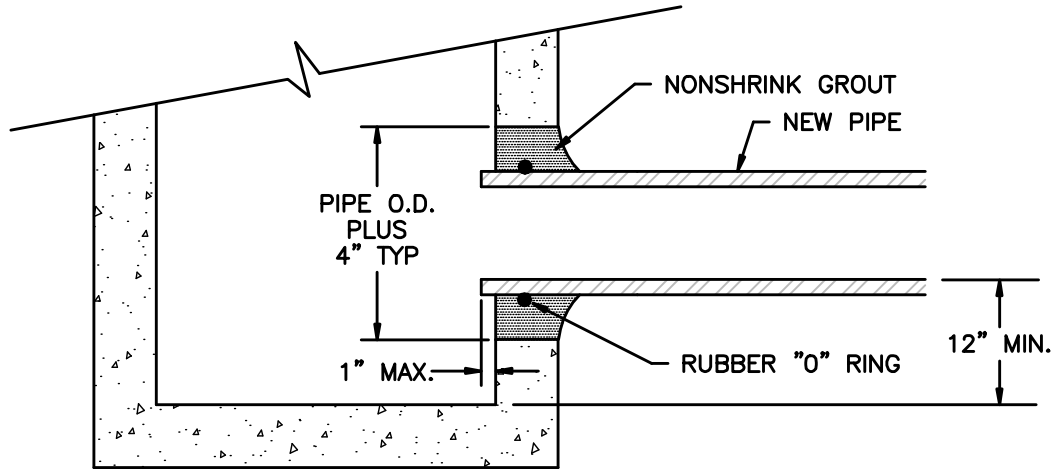

GRouted PIPE CONNECTION
(FOR CONNECTIONS TO EXISTING STRUCTURES)

GRout FOR PIPE CONNECTIONS SHALL BE ALL-CRETE (5 OR 20 MINUTE SET) MANUFACTURED BY FOSROC INC. OR AN APPROVED SUBSTITUTE.

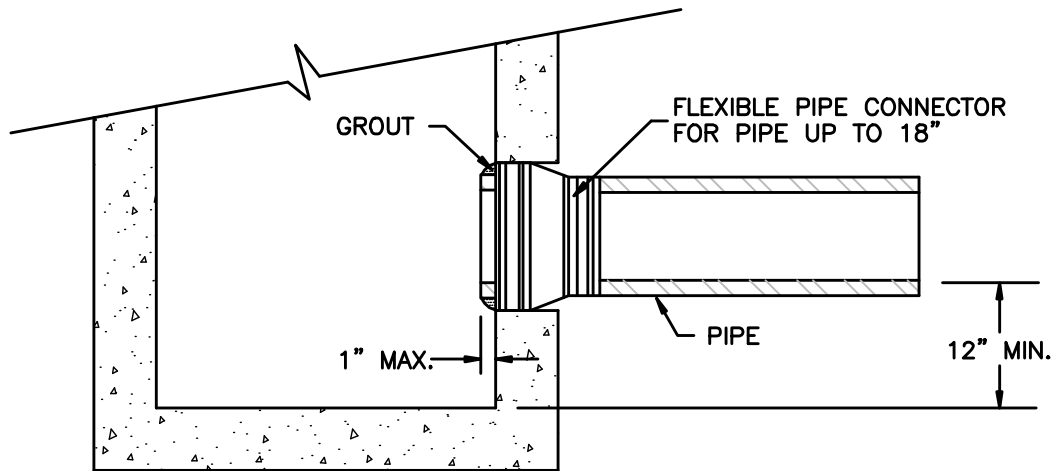

PVC PIPE CONNECTION

CONNECTION TO EXISTING PIPE, MANHOLE OR INLET BOX

DEPARTMENT OF PUBLIC WORKS AND PLANNING
ENGINEERING DIVISION
CITY OF GRAND JUNCTION, COLORADO

STANDARD STORM DRAIN
DETAIL

APPROVED: DN
DATE: JULY 2005
DRAWN: CM

PAGE
D-12

N:\CAD\CITY STANDARDS\STANDARD DRAWING DETAILS\2007-Storm Sewer-Details.DWG-D-13 (REV.01-07). 6/13/2007 4:31:54 PM

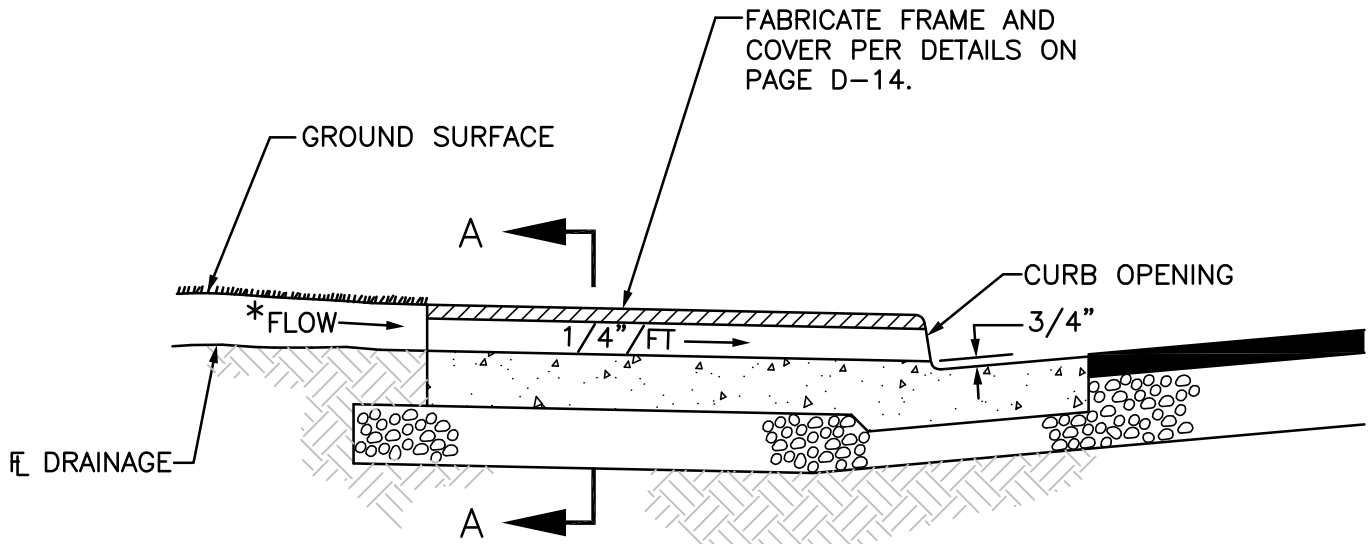

SEE PAGE C-02 FOR DIMENSIONS OF MONOLITHIC CURB GUTTER AND SIDEWALK

*DIRECTION OF FLOW SHALL BE FROM PROPERTY TO STREET ONLY.

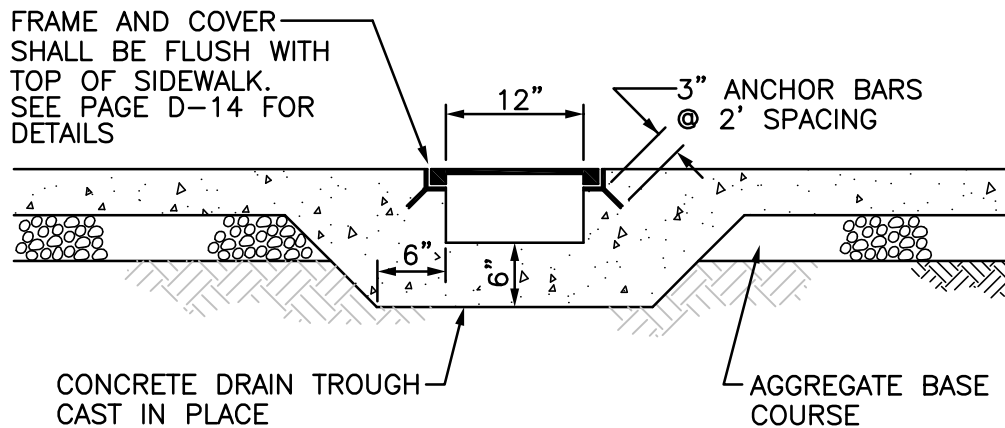

SECTION A-A

*WHEN THE RUNOFF FLOW RATE EXCEEDS THE DRAIN TROUGH CAPACITY, OTHER APPROVED CONVEYANCE METHODS/FACILITIES SHALL BE UTILIZED.

DRAIN TROUGH FOR SIDEWALK CROSSING

DEPARTMENT OF PUBLIC WORKS AND PLANNING
ENGINEERING DIVISION
CITY OF GRAND JUNCTION, COLORADO

STANDARD STORM DRAIN
DETAIL

APPROVED: DN
REVISED: FEB. 2007
DRAWN: TLT

PAGE
D-13

N:\Cadd\CITY STANDARDS\STANDARD DRAWING DETAILS\2007-Storm Sewer-Details.DWG. D-14 (REV. 01-07), 6/13/2007 4:38:14 PM

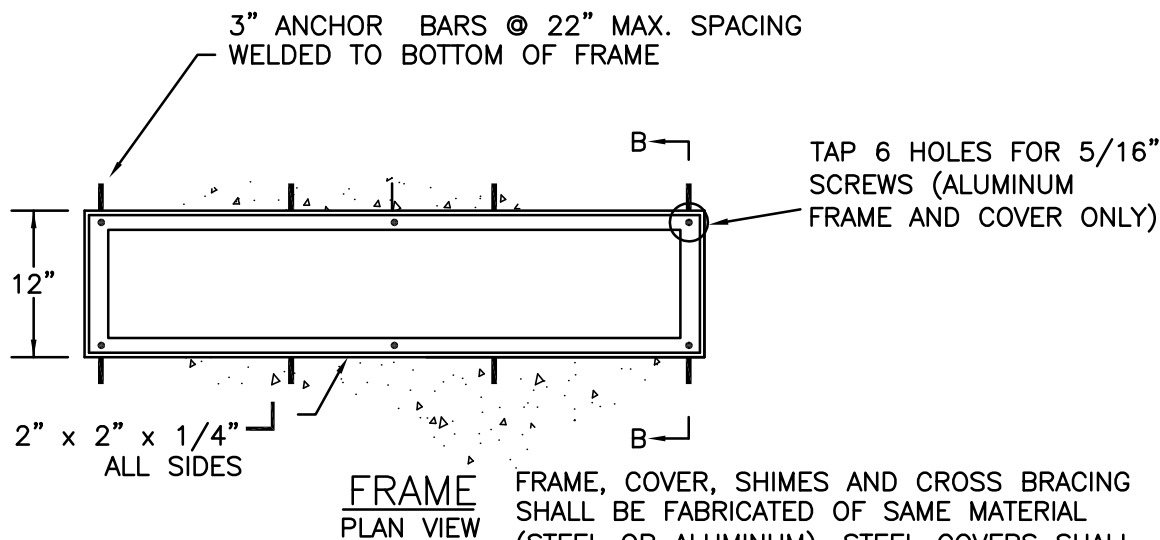
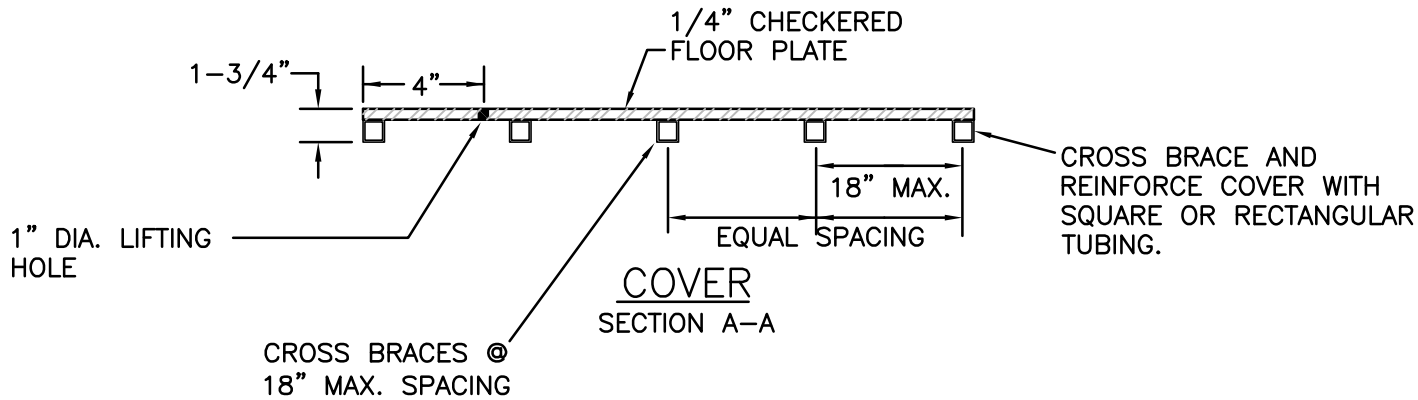
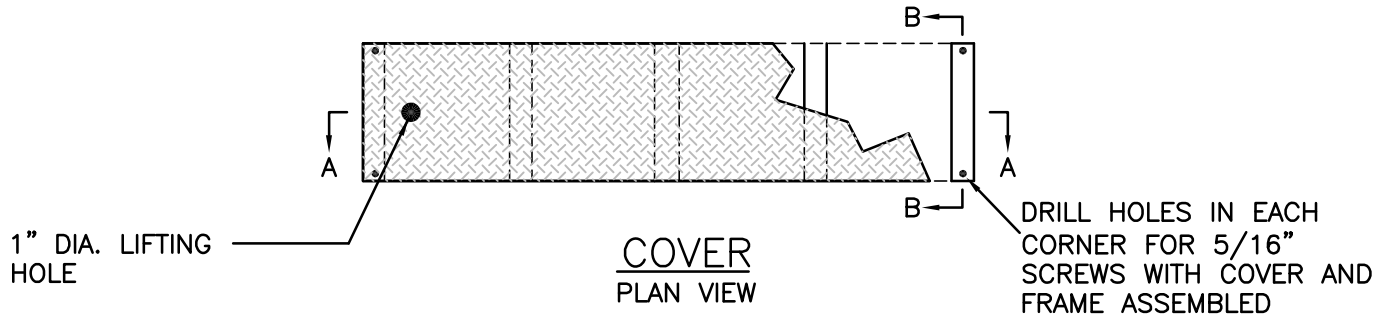

FRAME, COVER, SHIMES AND CROSS BRACING SHALL BE FABRICATED OF SAME MATERIAL (STEEL OR ALUMINUM). STEEL COVERS SHALL BE GALVANIZED FOLLOWING FABRICATION. STEEL FRAMES SHALL BE GALVANIZED OR SHOP PRIMED AND PAINTED WITH ALUMINUM PAINT MEETING CDOT SPEC. 708.04

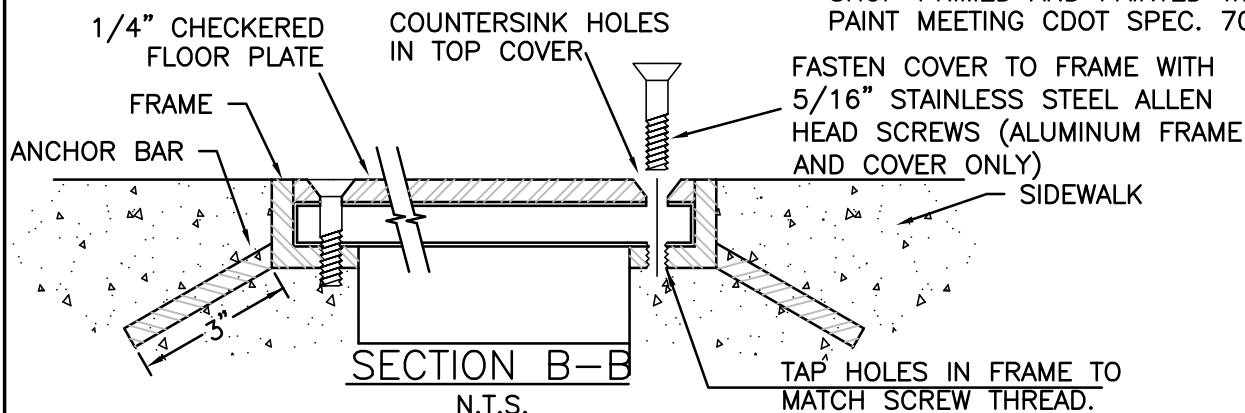

FRAME AND COVER FOR SIDEWALK DRAIN TROUGH

DEPARTMENT OF PUBLIC WORKS AND PLANNING
ENGINEERING DIVISION
CITY OF GRAND JUNCTION, COLORADO

STANDARD STORM DRAIN
DETAIL

APPROVED: DN
REVISED: FEB. 2007
DRAWN: TLT

PAGE
D-14

N:\cadd\CIT - STANDARDS\STANDARD DRAWING DETAILS\2007 - Storm Sewer Details.DWG, D-15, 5/29/2007 4:45:00 PM

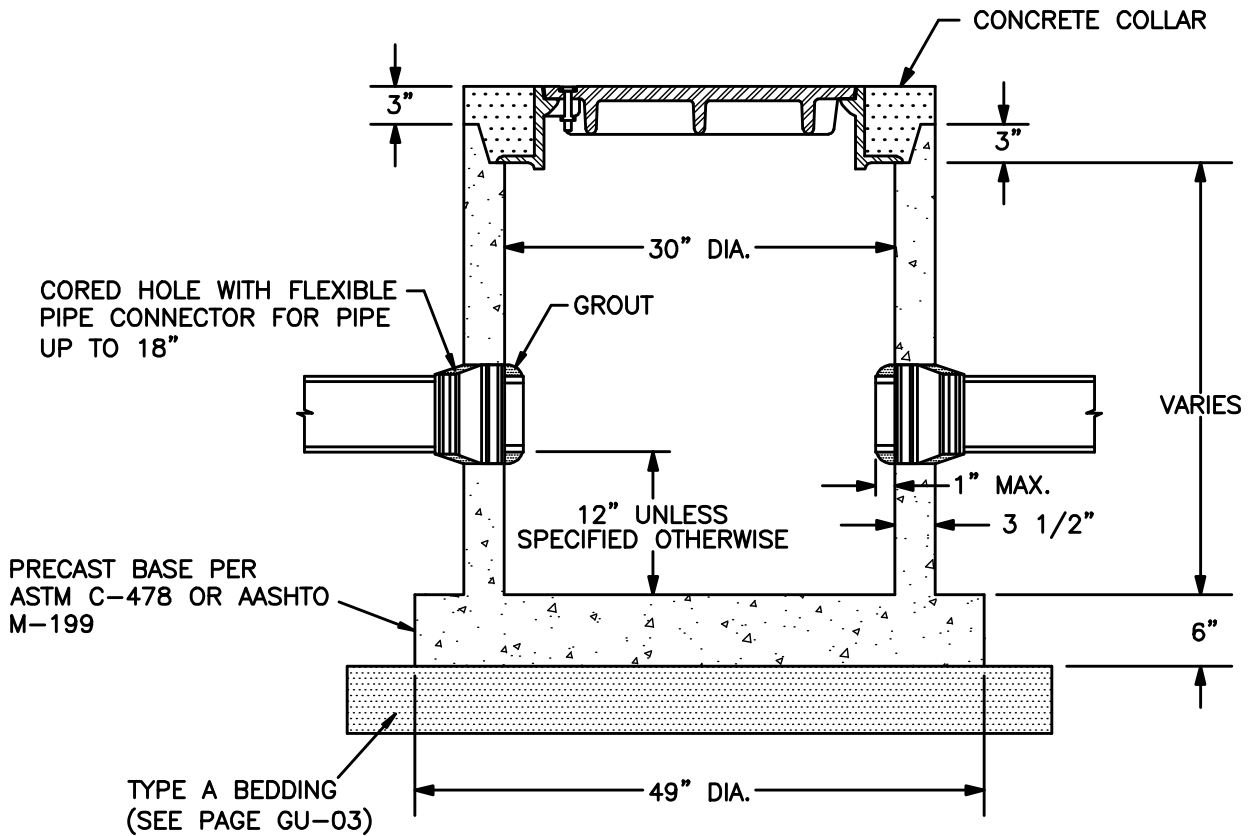
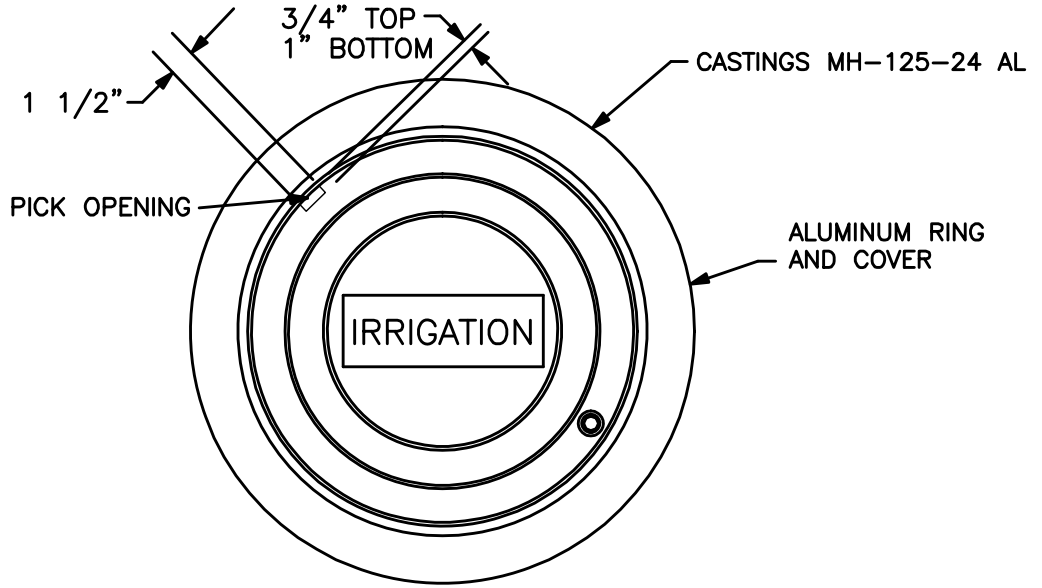

THIS MANHOLE IS NOT APPROVED FOR USE IN CITY STREETS OR OTHER LOCATIONS SUBJECT TO VEHICULAR TRAFFIC LOADING.

IRRIGATION MANHOLE WITH PRECAST BASE

DEPARTMENT OF PUBLIC WORKS AND PLANNING
ENGINEERING DIVISION
CITY OF GRAND JUNCTION, COLORADO

STANDARD IRRIGATION
DETAIL

APPROVED: DN
DATE: JULY 2005
DRAWN: CM

PAGE
D-15

- GU-01 Typical Utility Plan for Streets
- GU-02 Typical Street Cross Section / Utility Locations
- GU-03 Typical Trench Detail
- GU-04 Typical Water and Sewer Line Crossings
- GU-05 Curb Stamp for Sewer Service Location
- GU-06 Standard Pipe Casing / Non-Restrained Joints
- GU-07 Standard Pipe Casing / Restrained Joint
- GU-08 Utility Locations and Multi-Purpose Easement Detail
- GU-09 Joint Trench Details
- GU-10 General Notes For Multi-Purpose Easements
- GU-11 Survey Monument Box - Aliquot Corner
- GU-12 Survey Monument Box - City Monument

TABLE OF CONTENTS - GENERAL UTILITY DETAILS

DEPARTMENT OF PUBLIC WORKS AND PLANNING ENGINEERING DIVISION CITY OF GRAND JUNCTION, COLORADO	STANDARD UTILITY DETAIL	APPROVED: <u>DN</u> DATE: <u>FEB. 2005</u> DRAWN: <u>TOP/DPW</u>	PAGE GU-00
---	----------------------------	--	---------------

N:\Cadd\CITY STANDARDS\STANDARD DRAWING DETAILS\2008-October Revisions\2008-General Utility Details.DWG, GUL-01, 3/2/2009 10:55:17 AM

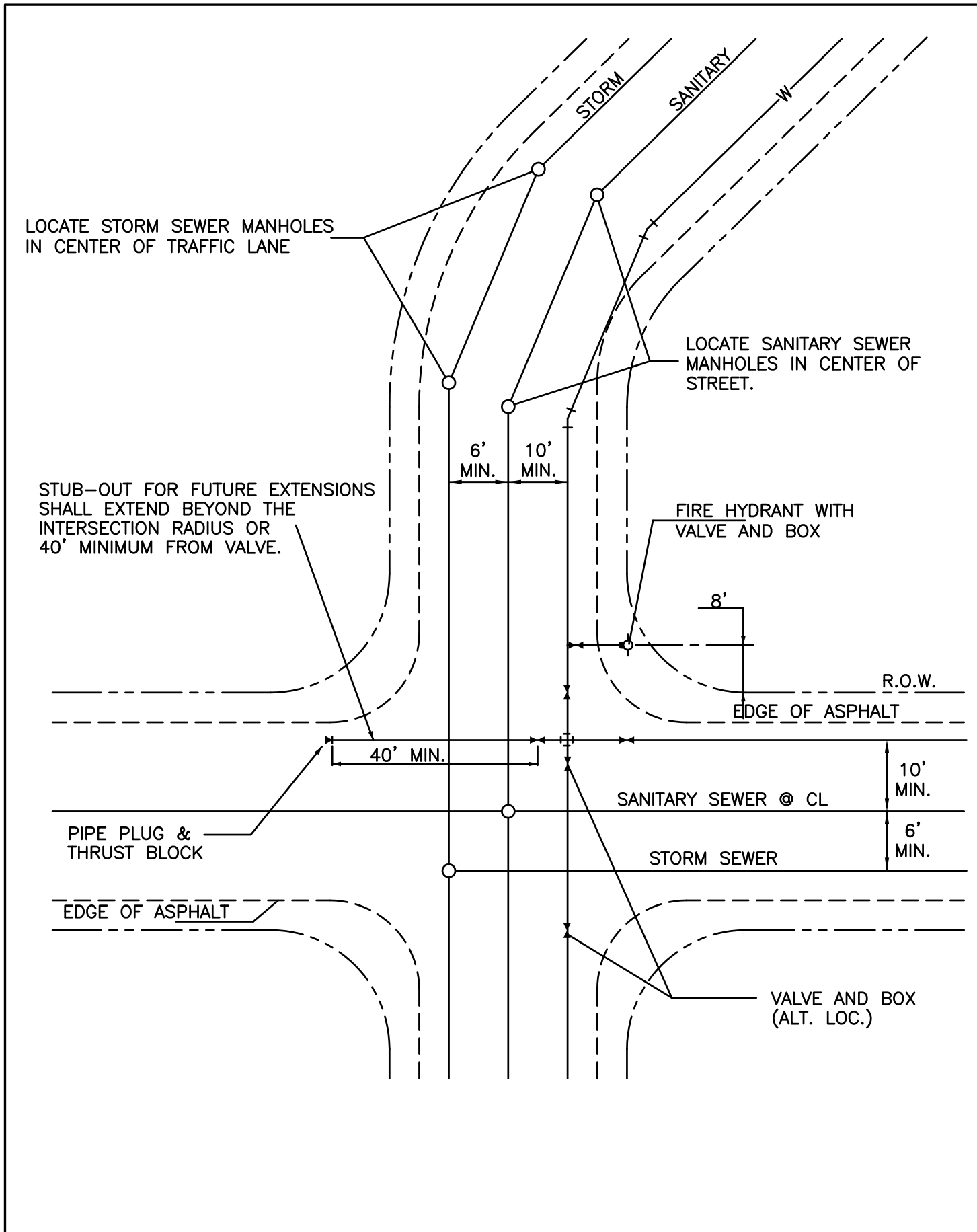

TYPICAL UTILITY PLAN FOR STREETS

DEPARTMENT OF PUBLIC WORKS AND PLANNING ENGINEERING DIVISION CITY OF GRAND JUNCTION, COLORADO	GENERAL UTILITY DETAIL	APPROVED: <u>DN</u> DATE: <u>FEB. 2006</u> DRAWN: <u>CM</u>	PAGE GU-01
---	---------------------------	---	---------------

N:\Cadd\CITY STANDARDS\STANDARD DRAWING DETAILS\2008 October Revisions\2008-General Utility Details.DWG, GU-02, 3/2/2009 10:55:42 AM

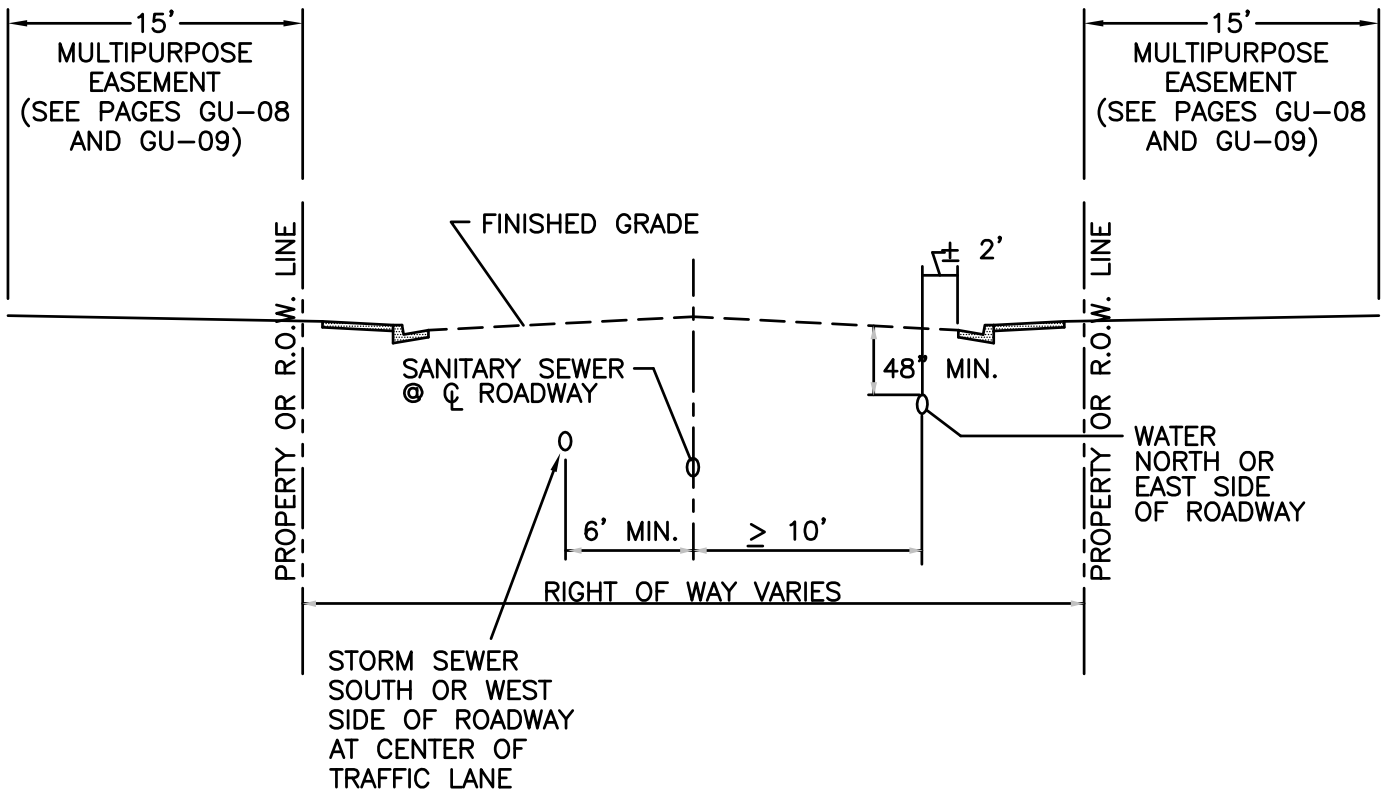

TYPICAL STREET CROSS SECTION / UTILITY LOCATIONS

DEPARTMENT OF PUBLIC WORKS AND PLANNING ENGINEERING DIVISION CITY OF GRAND JUNCTION, COLORADO	GENERAL UTILITY DETAIL	APPROVED: <u>DN</u> DATE: <u>FEB 2005</u> DRAWN: <u>TOP/DPW</u>	PAGE GU-02
---	---------------------------	---	---------------

N:\Cadd\CITY STANDARD DRAWING DETAILS\2008 October Revisions\2008-General Utility Details.DWG, GU-03 (REV 1-2009), 3/2/2009 10:56:33 AM

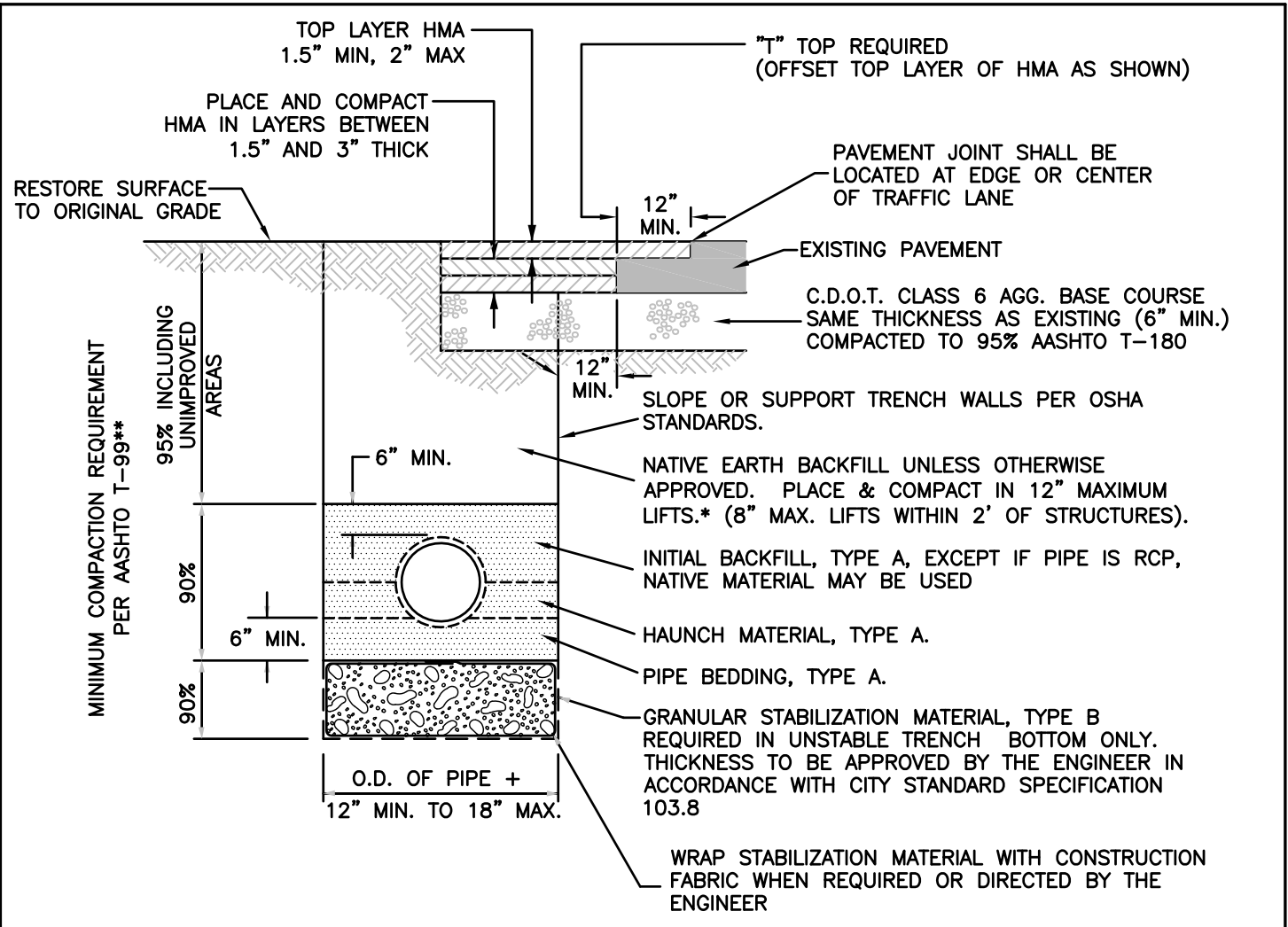

PERCENT BY WEIGHT PASSING SQUARE MESH SIEVES			
SIEVE SIZE	PIPE BEDDING, HAUNCH & INITIAL BACKFILL MATERIAL (CRUSHED ROCK, TYPE A)	GRANULAR STABILIZATION MATERIAL (SCREENED OR CRUSHED ROCK, TYPE B)	IMPORTED BACKFILL MATERIAL (USE ONLY WHERE SPECIFIED OR DIRECTED BY THE ENGINEER)
12 INCH	---	---	100
2 INCH	---	100	---
1 INCH	100	---	---
NO 4	20 MAX	15 MAX	---
NO 200	---	---	20 MAX ***

* 24" COMPACTED BACKFILL REQUIRED OVER ALL PLASTIC PIPE PRIOR TO VEHICLE OR HEAVY EQUIPMENT LOADING.

** COMPACT PER AASHTO T-180 WHEN SPECIFIED, DIRECTED OR APPROVED BY THE ENGINEER.

*** PLASTIC INDEX (PI) SHALL NOT BE MORE THAN 7.

ALL BACKFILL MATERIAL SHALL BE UNIFORMLY ADJUSTED TO WITHIN 2% OF THE OPTIMUM MOISTURE CONTENT PRIOR TO PLACEMENT AND COMPACTION.

TYPICAL TRENCH DETAIL

DEPARTMENT OF PUBLIC WORKS AND PLANNING ENGINEERING DIVISION CITY OF GRAND JUNCTION, COLORADO	GENERAL UTILITY DETAIL	APPROVED: <u>DN</u> REVISED: <u>JAN 2009</u> DRAWN: <u>JAH</u>	PAGE GU-03
---	---------------------------	--	---------------

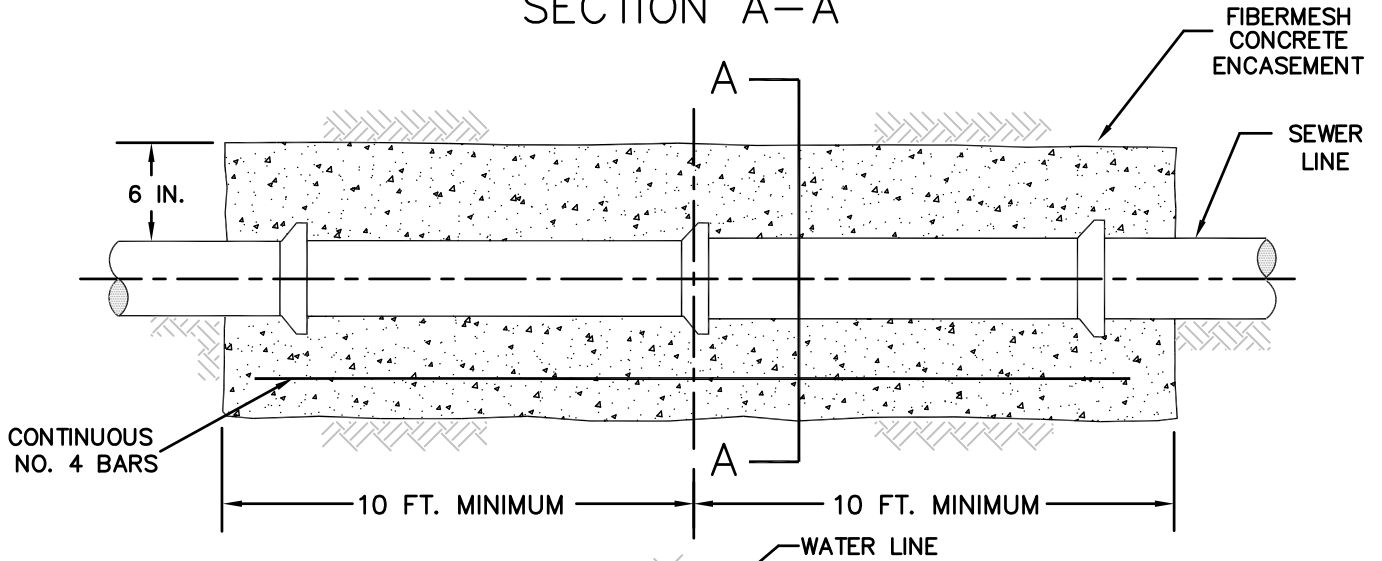
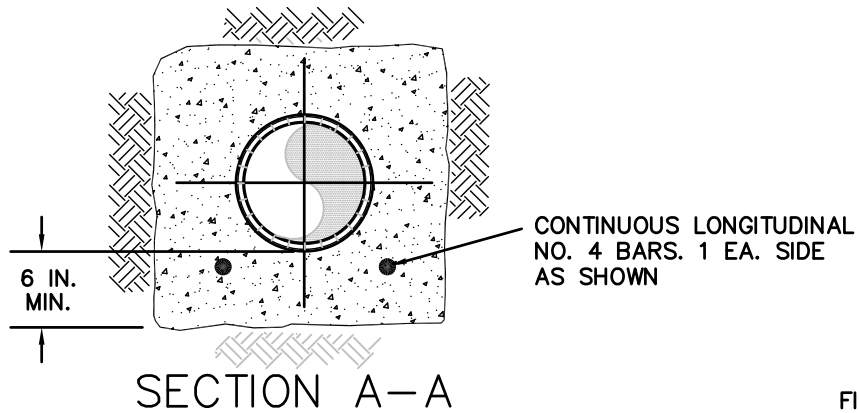

STEEL/DUCTILE CASING PIPE OR CONCRETE ENCASEMENT REQUIRED IN ALL CASES WHERE SEWER LINE IS ABOVE WATER LINE OR IS UNDER WATERWAY CROSSING.

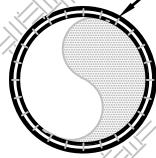

WATER LINE BELOW SEWER LINE

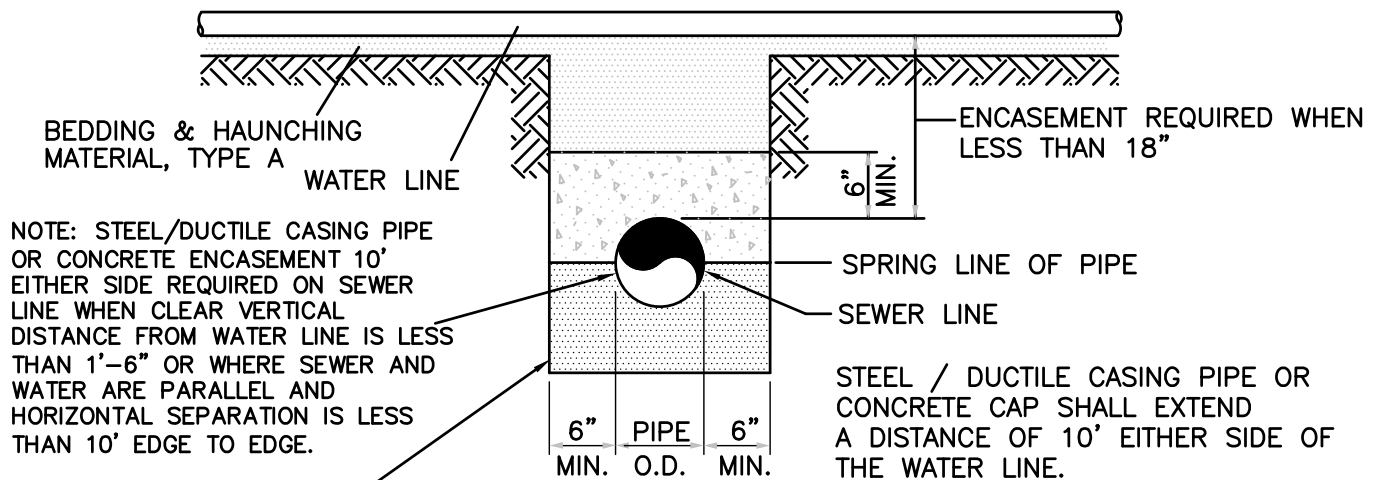

WATER LINE ABOVE SEWER LINE

TYPICAL WATER AND SEWER LINE CROSSINGS

DEPARTMENT OF PUBLIC WORKS AND PLANNING
ENGINEERING DIVISION
CITY OF GRAND JUNCTION, COLORADO

GENERAL UTILITY
DETAIL

APPROVED: DN
DATE: FEB 2005
DRAWN: TOP/DPW

PAGE
GU-04

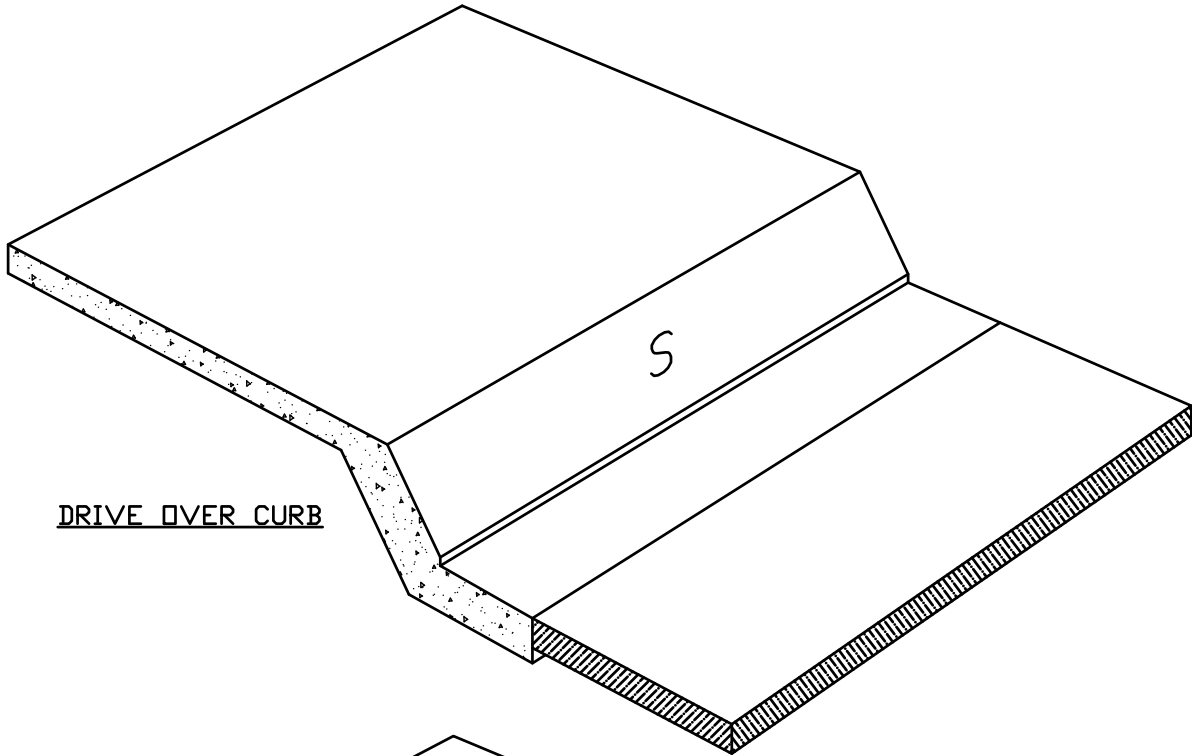

DRIVE OVER CURB

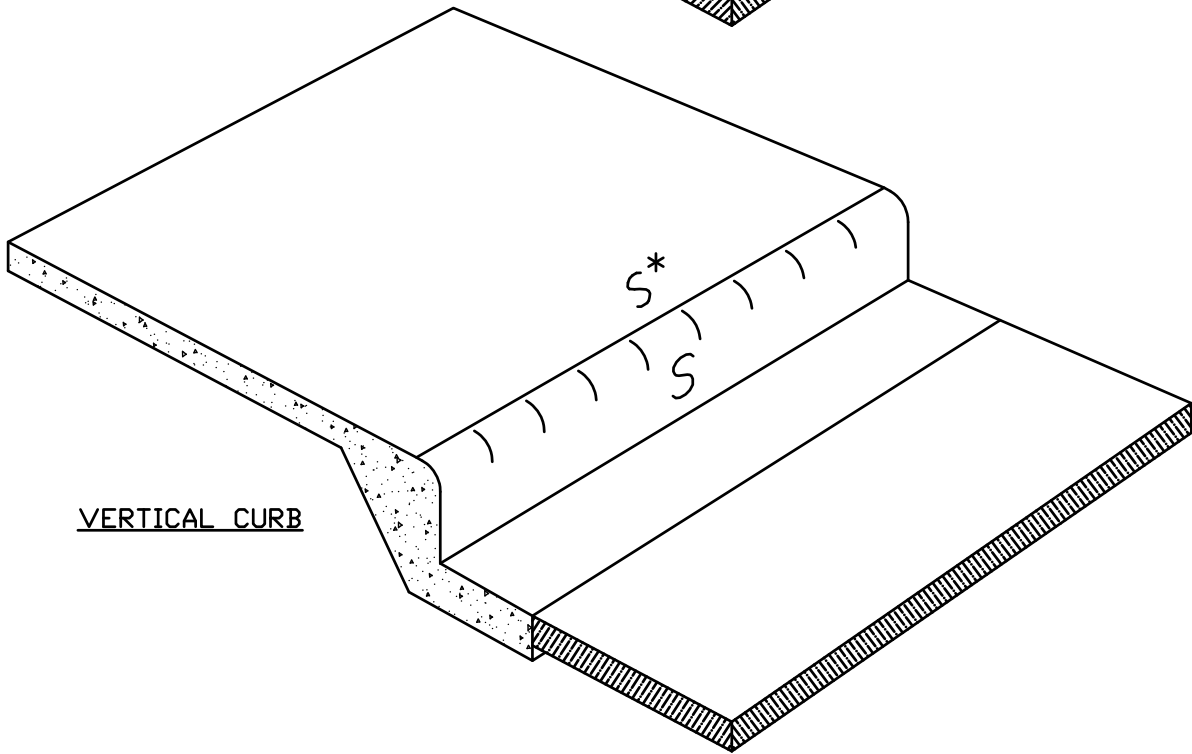

VERTICAL CURB

1. SEWER SERVICE LOCATION TO BE STAMPED IN CURB FACE MARKED "S".
2. LETTER HEIGHT SHALL BE 4 INCHES.
3. STAMP TO BE PLACED BY CONCRETE CONTRACTOR.

* ALTERNATE LOCATION FOR FORMED CURB.

CURB STAMP FOR SEWER SERVICE LOCATION

DEPARTMENT OF PUBLIC WORKS AND PLANNING
ENGINEERING DIVISION
CITY OF GRAND JUNCTION, COLORADO

GENERAL UTILITY
DETAIL

APPROVED: DN
DATE: FEB 2005
DRAWN: TOP/DPW

PAGE
GU-05

1/2" MAXIMUM

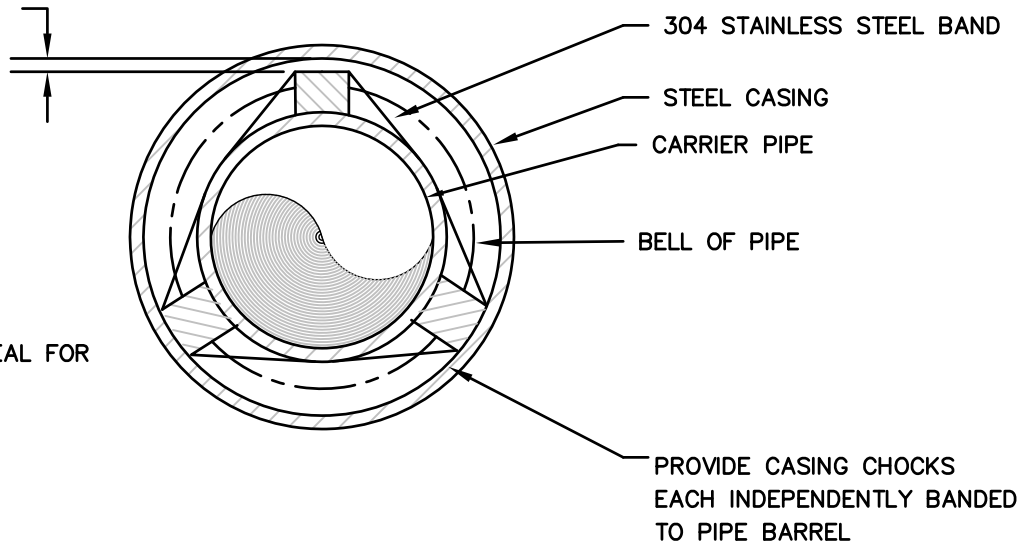

0.015 304 STAINLESS STEEL STRAPS
(TO BE USED WITH REDWOOD SKIDS)

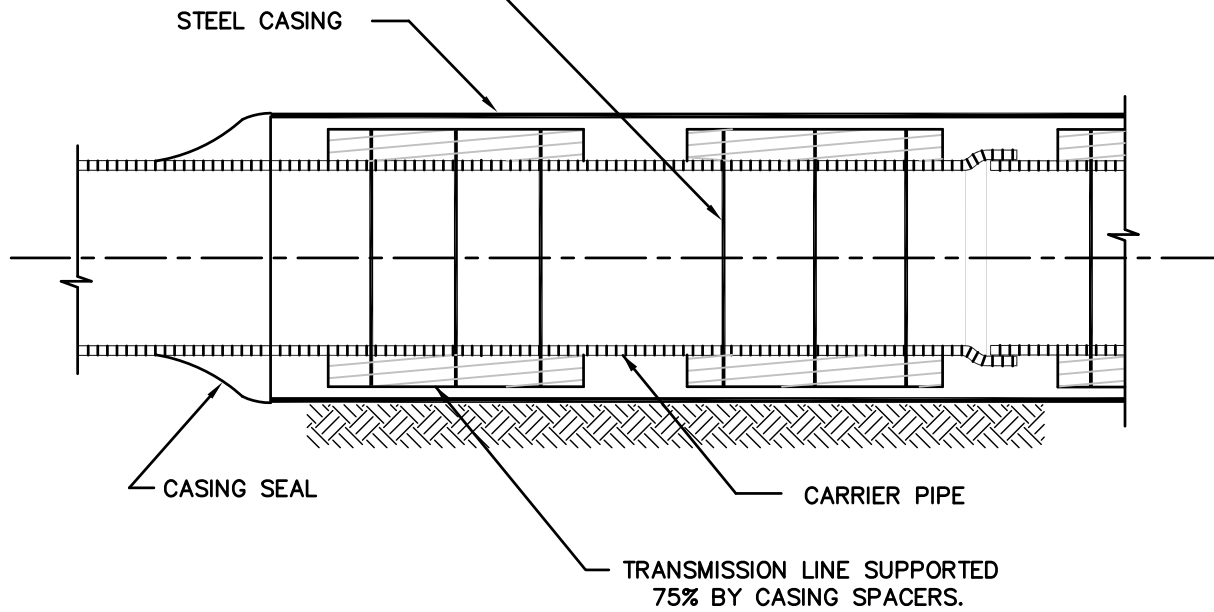

NOTE: CASING SPACERS MAY BE EITHER REDWOOD OR STAINLESS
STEEL PIPE INSULATORS WITH POLYMER RUNNERS.

STANDARD PIPE CASING / NON-RESTRAINED JOINTS

DEPARTMENT OF PUBLIC WORKS AND PLANNING
ENGINEERING DIVISION
CITY OF GRAND JUNCTION, COLORADO

GENERAL UTILITY
DETAIL

APPROVED: DN
DATE: FEB 2005
DRAWN: TOP/DPW

PAGE
GU-06

N:\Cadd\CITY STANDARDS\STANDARD DRAWING DETAILS\2008-October Revisions\2008-General Utility Details.DWG, GU-07, 3/2/2009 10:57:48 AM

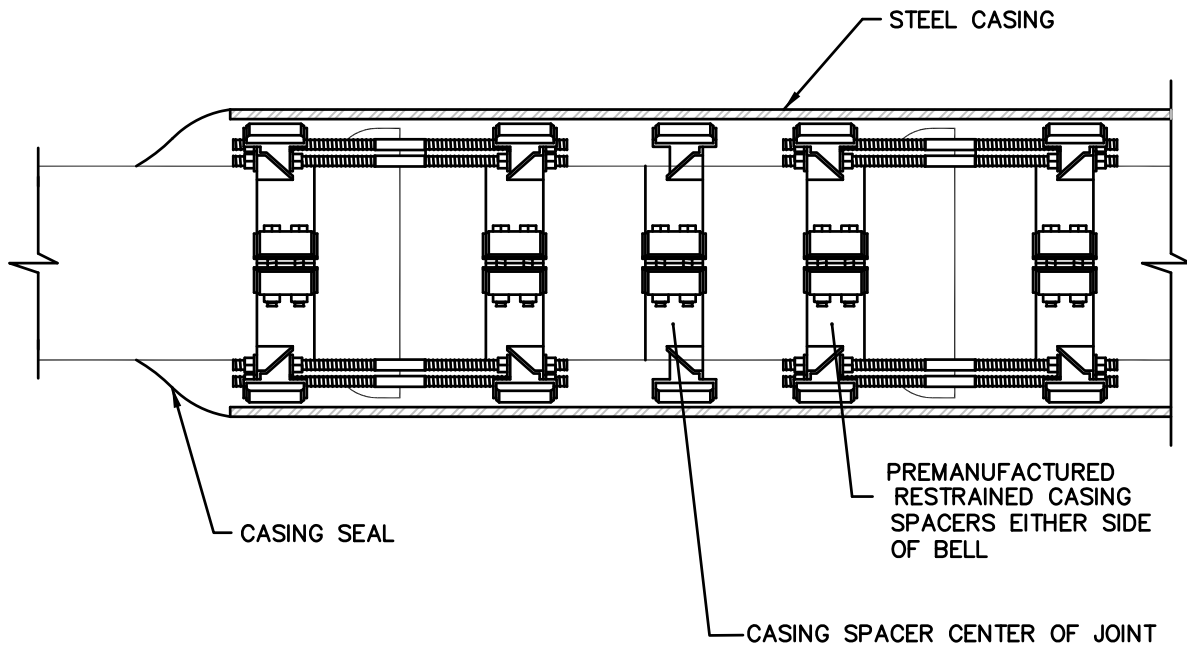
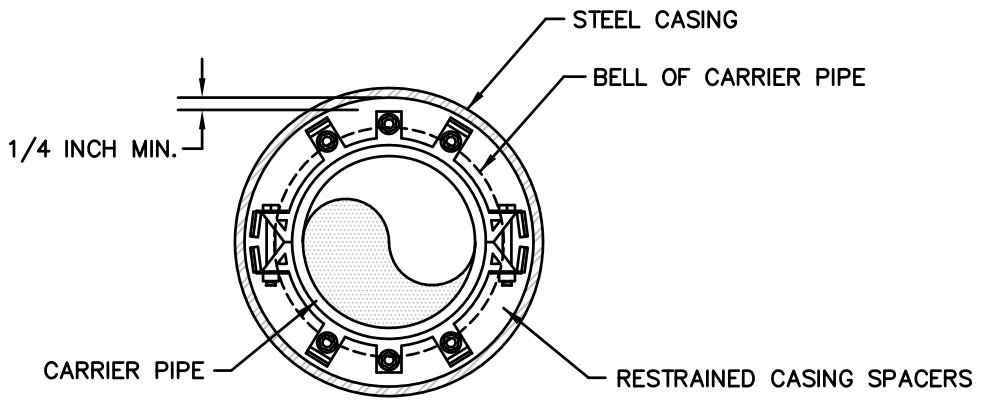

STANDARD PIPE CASING / RESTRAINED JOINT

DEPARTMENT OF PUBLIC WORKS AND PLANNING
ENGINEERING DIVISION
CITY OF GRAND JUNCTION, COLORADO

GENERAL UTILITY
DETAIL

APPROVED: DN
DATE: FEB 2005
DRAWN: TOP/DPW

PAGE
GU-07

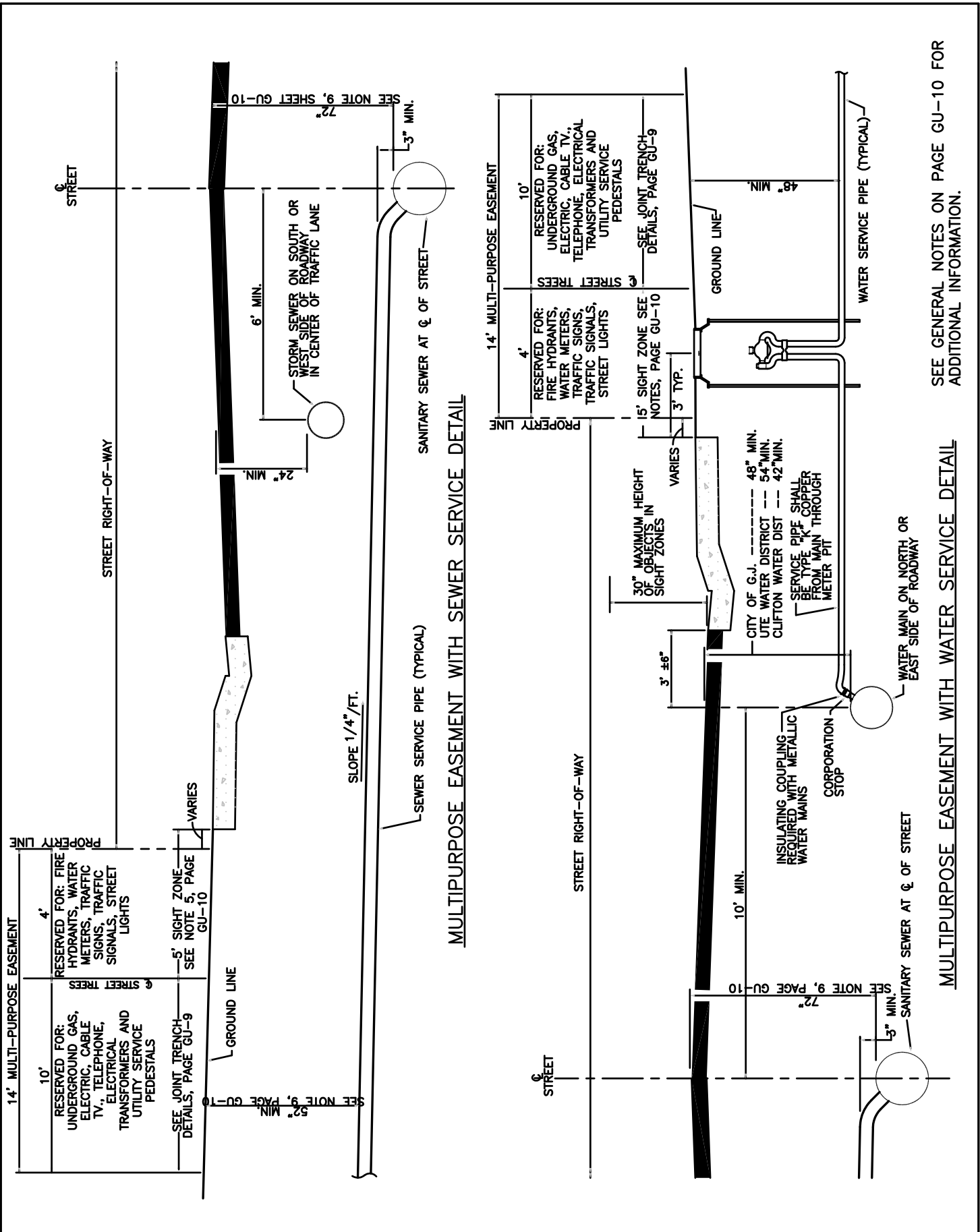

UTILITY LOCATIONS AND MULTI-PURPOSE EASEMENT DETAIL

DEPARTMENT OF PUBLIC WORKS AND PLANNING
ENGINEERING DIVISION
CITY OF GRAND JUNCTION, COLORADO

GENERAL UTILITY
DETAIL

APPROVED: DN
REV: JAN. 2009
DRAWN: CM

PAGE
GU-08

MULTIPURPOSE EASEMENT WITH SEWER SERVICE DETAIL

MULTIPURPOSE EASEMENT WITH WATER SERVICE DETAIL

SEE GENERAL NOTES ON PAGE GU-10 FOR
ADDITIONAL INFORMATION.

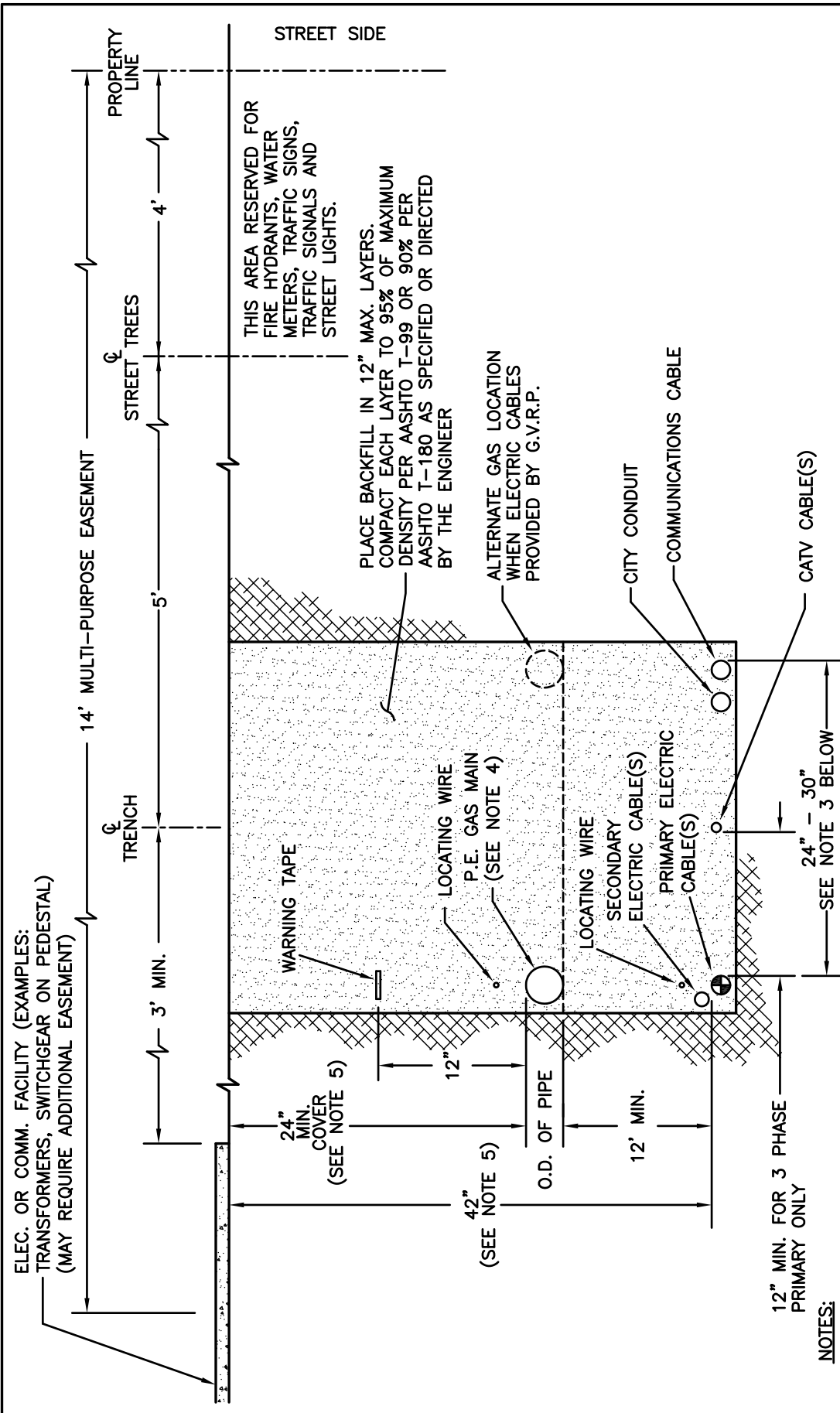

- NOTES:**
1. FOR EASE OF CONSTRUCTION AND MAINTENANCE, PRIMARY CABLE SHOULD BE 12" TO 24" FROM COMMUNICATION CABLES. HOWEVER, NESC REQUIREMENTS PERMIT "SUPPLY AND COMMUNICATION CABLES TO BE BURIED TOGETHER AT THE SAME DEPTH WITH NO DELIBERATE SEPARATION BETWEEN FACILITIES PROVIDED ALL PARTIES ARE IN AGREEMENT."
 2. ONLY SINGLE PHASE SUPPLY CABLES CAN BE BURIED AT THE SAME DEPTH WITH NO DELIBERATE SEPARATION WITH COMMUNICATION CABLES. THREE PHASE CABLES MUST BE SEPARATED BY A MINIMUM OF 1 FOOT (REFERENCE NESC 354.D.3A).
 3. 30" TRENCH WIDTH SHOULD BE USED WHEN ALL FOUR UTILITIES ARE INCLUDED.
 4. STEEL GAS PIPE OR STEEL DUCT IS NOT ALLOWED FOR JOINT TRENCH CONSTRUCTION.
 5. WHERE UNDERGROUND UTILITIES CROSS OR ENCRANCH INTO CITY STREETS THEY SHALL BE INSTALLED TO A DEPTH PROVIDING 3' MINIMUM COVER BELOW FINISHED GRADE.

JOINT TRENCH DETAILS

DEPARTMENT OF PUBLIC WORKS AND PLANNING ENGINEERING DIVISION CITY OF GRAND JUNCTION, COLORADO	GENERAL UTILITY DETAIL	APPROVED: <u>DN</u> DATE: <u>JAN. 2009</u> DRAWN: <u>GM</u>	PAGE GU-09
---	---------------------------	---	---------------

N:\Cadd\CITY STANDARDS\STANDARD DRAWING DETAILS\2008 October Revisions\2008-General Utility Details.DWG, GU-10, 3/22/2009 10:59:17 AM

1. A CONTINUOUS MULTI-PURPOSE EASEMENT SHALL BE PROVIDED ON BOTH SIDES OF ALL ROAD RIGHTS-OF-WAY. THIS EASEMENT SHALL BE RESERVED FOR PURPOSES INCLUDING, BUT NOT LIMITED TO INSTALLATION AND MAINTENANCE OF PUBLIC UTILITIES, TRAFFIC CONTROL SIGNS AND SIGNALS, STREETScape, STREET TREES, AND SPRINKLING SYSTEMS, EARTH RETAINING STRUCTURES AND SURFACE SLOPING OR GRADING REQUIRED FOR STREET CONSTRUCTION.

UTILITY COMPANIES AND/OR THE CITY OF GRAND JUNCTION SHALL NOT BE RESPONSIBLE FOR DAMAGE TO PLANTINGS, IRRIGATION SYSTEMS, FENCES OR OTHER APPURTENANCES LOCATED OR CONSTRUCTED WITHIN THE MULTI-PURPOSE EASEMENT WHEN SUCH DAMAGE RESULTS FROM THE INSTALLATION AND/OR REPAIR OF UTILITIES WITHIN SAID MULTI-PURPOSE EASEMENT.

2. IRRIGATION DISTRIBUTION LINES SHALL BE LOCATED IN A SEPARATE EASEMENT LOCATED ON THE HOUSE SIDE OF THE MULTI-PURPOSE EASEMENT, OR AT THE BACK LOT LINE.

3. PROPERTY OWNERS MAY LANDSCAPE THE FULL WIDTH OF THE MULTI-PURPOSE EASEMENTS. SPRINKLING SYSTEMS INSTALLED WITHIN MULTI-PURPOSE EASEMENTS SHALL NOT BE GREATER THAN 18" BELOW THE GROUND SURFACE.

4. STREET TREES SHALL BE LOCATED 5' FROM THE BACK OF SIDEWALK AND NO LESS THAN 10' FROM ANY DRIVEWAY. NO TREES SHALL BE PLANTED WITHIN THE MULTI-PURPOSE EASEMENT WITHOUT APPROVAL OF THE SPECIES AND LOCATION BY THE CITY FORESTRY SUPERVISOR.

5. NO TREES, SHRUBS, HEDGES, FENCES, WALLS, OR OTHER OBSTRUCTIONS OVER 30" IN HEIGHT, MEASURED AT THE NEAR EDGE OF ROADWAY, SHALL BE LOCATED WITHIN SIGHT ZONES SHOWN ON PAGE GU-08. EXCEPTIONS WILL BE MADE FOR UTILITY POLES/CABINETS, TRAFFIC CONTROL SIGNS, TRAFFIC SIGNAL POLES AND "OPEN TYPE" FENCES. CHAIN LINK OR OTHER "OPEN TYPE" FENCES UP TO 48 INCHES IN HEIGHT MAY BE INSTALLED ON THE RIGHT-OF-WAY LINE. SEE THE CITY ZONING AND DEVELOPMENT CODE FOR FENCE HEIGHT AND PERMIT REQUIREMENTS.

6. ALL FIRE HYDRANTS AND WATER METERS SHALL REMAIN UNOBSTRUCTED AND ACCESSIBLE AT ALL TIMES. NO FENCES, PLANTINGS, STRUCTURES OR OTHER OBSTACLE SHALL BE LOCATED WITHIN 3' OF ANY FIRE HYDRANT OR ON THE STREET SIDE OF ANY FIRE HYDRANT.

7. SANITARY SEWER MANHOLES SHALL BE LOCATED AT CENTER LINE OF STREET OR ROADWAY

8. STORM SEWER MANHOLES SHALL BE LOCATED AT THE CENTER LINE OF A TRAFFIC LANE.

9. DUE TO DEPTHS OF EXISTING SEWER LINES, IT MAY NOT BE POSSIBLE TO EXTEND NEW SEWER MAINS AT THE MINIMUM DEPTHS SHOWN ON THE TYPICAL STREET SECTION. WHERE SANITARY SEWER MAIN AND SERVICE LINES ARE INSTALLED AT DEPTHS LESS THAN THE MINIMUM SHOWN, IT SHALL BE THE RESPONSIBILITY OF THE DEVELOPER OR PROPERTY OWNER TO ADEQUATELY MARK THE LOCATION AND DEPTH OF THE SERVICE PIPE AND NOTIFY THE CITY AND UTILITY COMPANIES OF SHALLOW SEWER SERVICES.

GENERAL NOTES FOR MULTI-PURPOSE EASEMENTS

DEPARTMENT OF PUBLIC WORKS AND PLANNING ENGINEERING DIVISION CITY OF GRAND JUNCTION, COLORADO	GENERAL UTILITY DETAIL	APPROVED: <u>DN</u> DATE: <u>FEB. 2005</u> DRAWN: <u>DPW</u>	PAGE GU-10
---	---------------------------	--	---------------

NOTE: CAST IRON GRADE ADJUSTMENT RINGS ARE ALLOWED ONLY FOR PAVEMENT OVERLAYS.

STANDARD CAST IRON VALVE BOX AND LID. THE WORD "SURVEY" SHALL BE CAST INTO THE LID.

SURVEY CAP (PER STATE STATUTE)

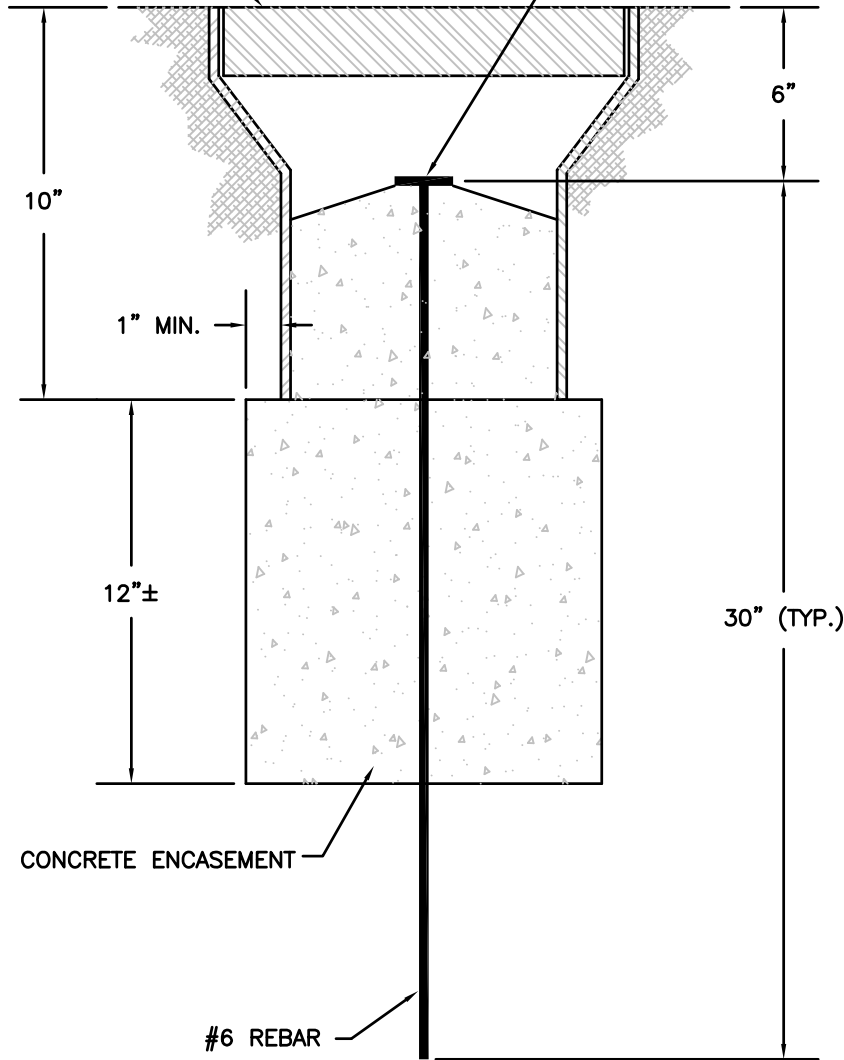

CONCRETE ENCASEMENT

#6 REBAR

SURVEY MONUMENT BOX - ALIQUOT CORNER

DEPARTMENT OF PUBLIC WORKS AND PLANNING
ENGINEERING DIVISION
CITY OF GRAND JUNCTION, COLORADO

GENERAL UTILITY
DETAIL

APPROVED: DN
DATE: FEB 2005
DRAWN: DPW

PAGE
GU-11

NOTE: CAST IRON GRADE
ADJUSTMENT RINGS ARE
ALLOWED ONLY FOR
PAVEMENT OVERLAYS.

STANDARD CAST IRON VALVE BOX AND
LID. THE WORD "SURVEY" SHALL BE
CAST INTO THE LID.

SURVEY CAP (PER
STATE STATUTE)

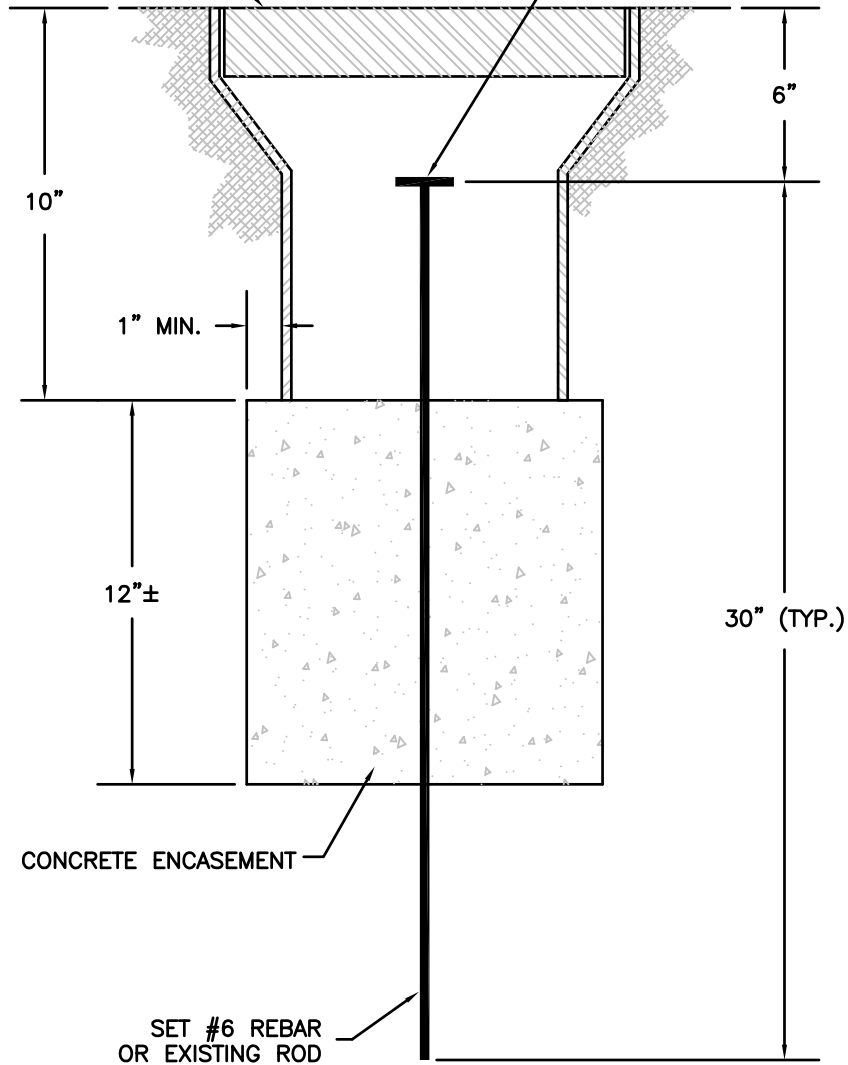

CONCRETE ENCASEMENT

SET #6 REBAR
OR EXISTING ROD

SURVEY MONUMENT BOX – CITY MONUMENT

DEPARTMENT OF PUBLIC WORKS AND PLANNING
ENGINEERING DIVISION
CITY OF GRAND JUNCTION, COLORADO

GENERAL UTILITY
DETAIL

APPROVED: DN
DATE: FEB. 2005
DRAWN: DPW

PAGE
GU-12

- SS-01 General Sewer Notes
- SS-02 Standard Manhole – Cast in Place Base
- SS-03 Standard Shallow Manhole – Cast in Place Base
- SS-04 Drop Manhole
- SS-05 Standard Manhole Ring and Cover
- SS-06 Typical Service "Y" Connection
- SS-07 Sewer Service Cleanout Within Right-of-way Detail
- SS-08 Precast Manhole Base, Pipe Connections and Access
Hole Location
- SS-09 DELETED
- SS-10 DELETED

TABLE OF CONTENTS – SEWER DETAILS

DEPARTMENT OF PUBLIC WORKS AND PLANNING ENGINEERING DIVISION CITY OF GRAND JUNCTION, COLORADO	STANDARD SANITARY SEWER DETAILS	APPROVED: <u>DN</u> DATE: <u>JAN. 2009</u> DRAWN: <u>CM</u>	PAGE SS-00
---	------------------------------------	---	---------------

- A. CONTRACTOR SHALL HAVE ONE SIGNED COPY OF PLANS AND A COPY OF THE CITY OF GRAND JUNCTION'S STANDARD SPECIFICATIONS AT THE JOB SITE AT ALL TIMES.
- B. ALL SEWER MAINS SHALL BE PVC SDR 35 (ASTM 3034) UNLESS OTHERWISE NOTED.
- C. ALL SEWER MAINS SHALL BE LAID TO GRADE UTILIZING A PIPE LASER.
- D. ALL SERVICE LINE CONNECTIONS TO NEW MAINS SHALL BE ACCOMPLISHED WITH FULL BODY WYES OR TEES. TAPPING SADDLES WILL NOT BE ALLOWED.
- E. SERVICE LINE CONNECTIONS TO EXISTING NON-PVC MAINS SHALL BE ACCOMPLISHED USING "INSERTA TEES" MANUFACTURED BY INSERTA FITTINGS COMPANY OF HILLSBORO, OREGON. FOR EXISTING PVC MAINS, TAPPING SADDLES SHALL BE USED.
- F. 4 INCH SERVICES SHALL NOT BE CONNECTED DIRECTLY INTO MANHOLES. ALL 6 INCH SERVICES SHALL BE CONNECTED TO THE MAIN AT A MANHOLE.
- G. THE CONTRACTOR SHALL NOTIFY THE CITY INSPECTOR 48 HOURS PRIOR TO COMMENCEMENT OF CONSTRUCTION.
- H. THE CONTRACTOR IS RESPONSIBLE FOR ALL REQUIRED SEWER LINE TESTING TO BE COMPLETED IN THE PRESENCE OF THE ENGINEER OR HIS REPRESENTATIVE. PRESSURE TESTING WILL BE PERFORMED AFTER INSTALLATION OF DRY UTILITIES, AFTER ALL COMPACTION OF STREET SUBGRADE AND PRIOR TO STREET PAVING. FINAL LAMPING WILL ALSO BE ACCOMPLISHED AFTER PAVING IS COMPLETED. THESE TESTS SHALL BE THE MINIMUM BASIS OF ACCEPTANCE OF THE SEWER LINE EXTENSION.
- I. THE CONTRACTOR SHALL OBTAIN CITY OF GRAND JUNCTION STREET CUT PERMIT FOR ALL WORK WITHIN EXISTING CITY RIGHT-OF-WAY PRIOR TO CONSTRUCTION.
- J. A CLAY CUT-OFF WALL SHALL BE PLACED 10 FEET UPSTREAM FROM ALL NEW MANHOLES UNLESS OTHERWISE NOTED. THE CUT-OFF WALL SHALL EXTEND FROM 6 INCHES BELOW TO 6 INCHES ABOVE GRANULAR BACKFILL MATERIAL AND SHALL BE 2 FEET WIDE. IF NATIVE MATERIAL IS NOT SUITABLE, THE CONTRACTOR SHALL IMPORT MATERIAL APPROVED BY THE ENGINEER.
- K. SEWER SERVICE STUB OUTS SHALL BE CAPPED AND PLUGGED. STUB OUT SHALL BE MARKED WITH A 4X4 INCH POST PAINTED GREEN BURIED WITH 3 FEET ABOVE GRADE. AS-BUILT SURVEYING FOR VERTICAL GRADE OF STUB OUT REQUIRED PRIOR TO BACKFILL.
- L. RED LINE AS-BUILTS SHALL BE SUBMITTED TO THE CITY UTILITY ENGINEER AT LEAST 72 HOURS PRIOR TO PAVING FOR REVIEW.

MANHOLE NOTES

- 1. CONCRETE SHALL BE COLORADO DEPARTMENT OF TRANSPORTATION CLASS "B" (SECTION 601.02)
- 2. ALL CEMENT USED IN MORTAR, CONCRETE BASES, GRADE RINGS, RISER SECTIONS AND CONES FOR SANITARY SEWER MANHOLES, SHALL BE TYPE V OR MODIFIED TYPE II PORTLAND CEMENT WITH LESS THAN 5% TRICALCIUM ALUMINATE.
- 3. MANHOLE RISER SECTIONS, CONES AND GRADE RINGS SHALL BE PRECAST REINFORCED CONCRETE CONFORMING TO ASTM C-478 OR AASHTO M-199.
- 4. BACKFILL AROUND MAHHOLES AND OTHER PIPELINE STRUCTURES SHALL BE PLACED IN 8" MAX. LIFTS AND COMPACTED TO 95% AASHTO T-99 WITH HAND OPERATED MECHANICAL EQUIPMENT.
- 5. ALL WORK SHALL BE IN ACCORDANCE WITH APPROVED PLANS AND CITY SPECIFICATION.
- 6. THE MANHOLE CONE AND BARREL SECTIONS SHALL BE POSITIONED SUCH THAT THE MANHOLE RING AND STEPS ARE AT A 45° ANGLE FROM THE INLET PIPE (SEE PAGE SS-08).
- 7. MANHOLE RING AND COVER SHALL BE SET TO FINISH GRADE USING RAPID ROAD REPAIR GROUT TO ADJUST RIM ELEVATION. GROUT SHALL NOT EXCEED 2". THICKNESS. GROUT SHALL BE PLACED BETWEEN TOP OF CONCRETE GRADE RING AND RING AND COVER. STEEL GRADE ADJUSTMENT RINGS MAY BE USED FOR ADJUSTMENT OF MANHOLE COVERS ONLY WHEN STREETS ARE OVERLAID.
- 8. INVERTED MANHOLE RINGS WILL NOT BE ALLOWED UNLESS APPROVED BY THE ENGINEER.

GENERAL SEWER NOTES

DEPARTMENT OF PUBLIC WORKS AND PLANNING ENGINEERING DIVISION CITY OF GRAND JUNCTION, COLORADO	STANDARD SANITARY SEWER DETAIL	APPROVED: <u>SPG</u> DATE: <u>JUNE 2010</u> DRAWN: <u>TP/DW</u>	PAGE SS-01
---	-----------------------------------	---	---------------

ALL PRECAST MANHOLE SECTIONS SHALL CONFORM TO ASTM C-478 OR AASHTO M-199

SEE DETAILS PAGE SS-05

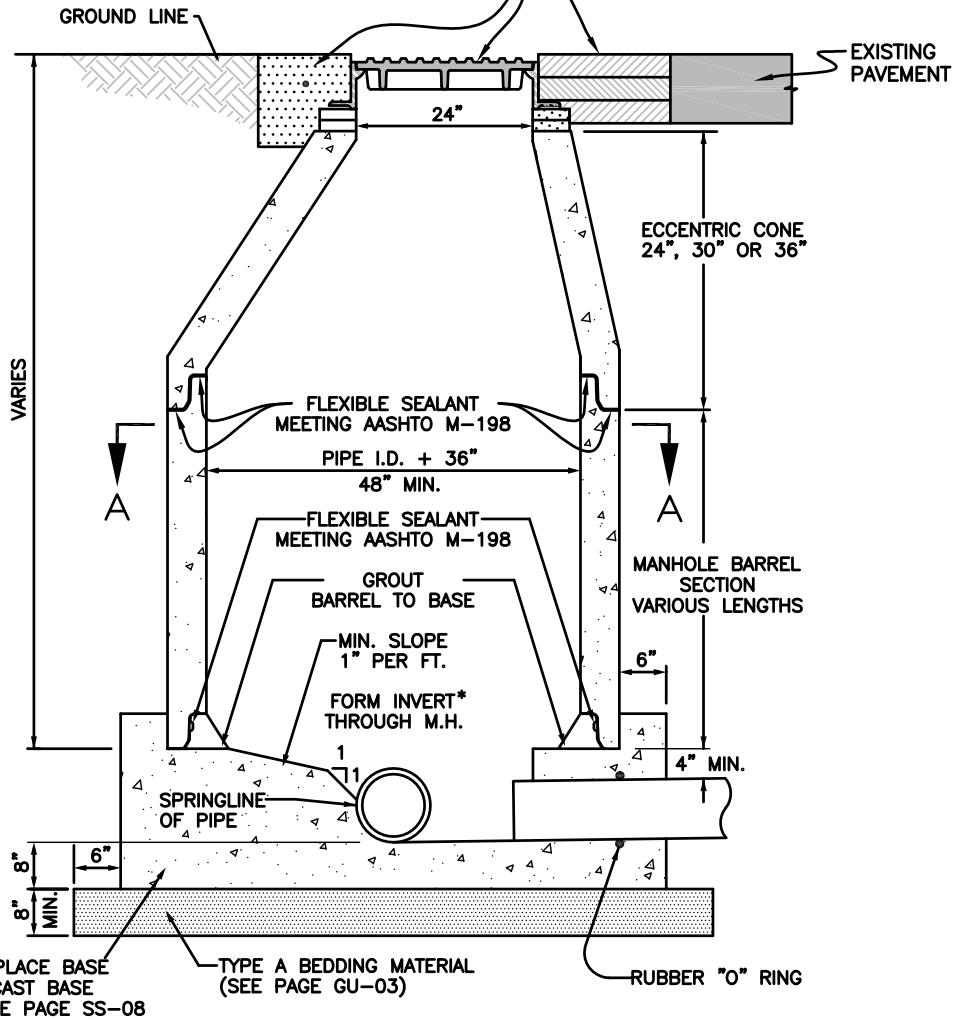

* FOR IN LINE MANHOLES THE PIPE MAY BE INSTALLED THROUGH THE MANHOLE BASE AND THE TOP HALF REMOVED.

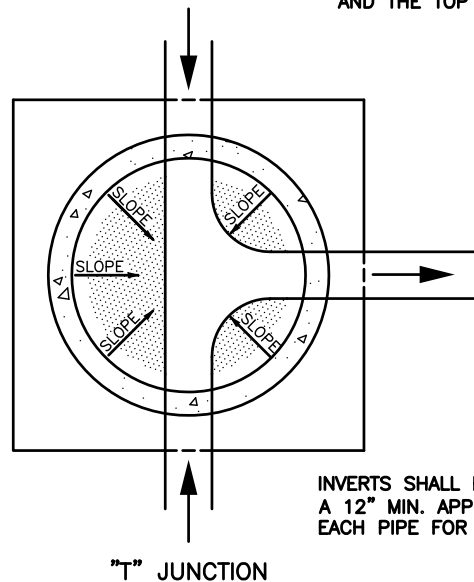

"T" JUNCTION

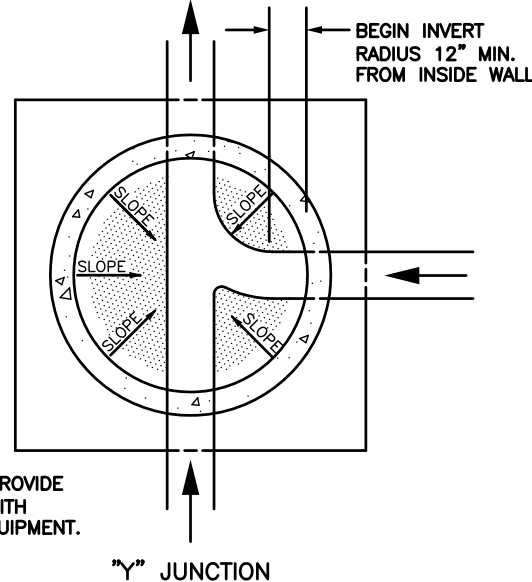

"Y" JUNCTION

INVERTS SHALL BE FORMED TO PROVIDE A 12" MIN. APPROACH IN LINE WITH EACH PIPE FOR MAINTENANCE EQUIPMENT.

SECTION A-A

STANDARD MANHOLE - CAST IN PLACE BASE

DEPARTMENT OF PUBLIC WORKS AND PLANNING ENGINEERING DIVISION CITY OF GRAND JUNCTION, COLORADO	STANDARD SANITARY SEWER DETAIL	APPROVED: <u>DN</u> REVISED: <u>FEB. 2007</u> DRAWN: <u>TLT</u>	PAGE SS-02
---	-----------------------------------	---	---------------

N:\Cadd\CITY STANDARDS\STANDARD DRAWING DETAILS\2008 October Revisions\2008-Sanitary Sewer Details.DWG, SS-02 (REV 01-07), 3/2/2009 11:02:33 AM

ALL PRECAST MANHOLE SECTIONS SHALL CONFORM TO ASTM C-478 OR AASHTO M-199

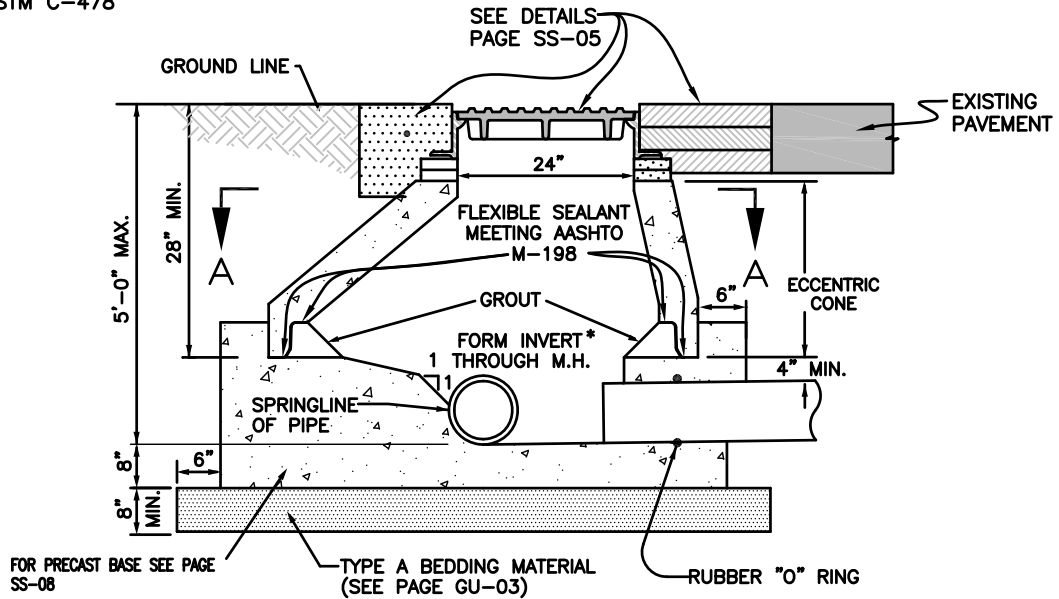

* FOR IN LINE MANHOLES THE PIPE MAY BE INSTALLED THROUGH THE MANHOLE BASE AND THE TOP HALF REMOVED.

NOTE:
MANHOLES SHALLower THAN SHOWN ABOVE SHALL BE APPROVED BY THE CITY UTILITY ENGINEER.

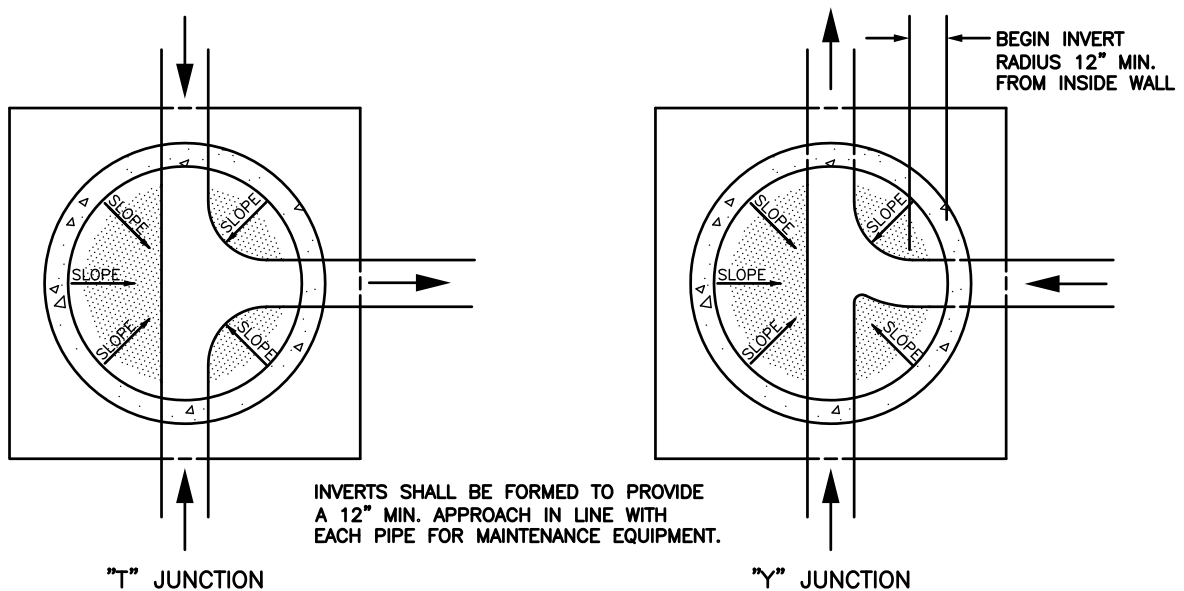

INVERTS SHALL BE FORMED TO PROVIDE A 12" MIN. APPROACH IN LINE WITH EACH PIPE FOR MAINTENANCE EQUIPMENT.

SECTION A-A

STANDARD SHALLOW MANHOLE - CAST IN PLACE BASE

DEPARTMENT OF PUBLIC WORKS AND PLANNING
ENGINEERING DIVISION
CITY OF GRAND JUNCTION, COLORADO

STANDARD SANITARY SEWER
DETAIL

APPROVED: DN
REVISED: FEB. 2007
DRAWN: TLT

PAGE
SS-03

N:\Cadd\CITY STANDARDS\STANDARD DRAWING DETAILS\2008 October Revisions\2008-Sanitary Sewer Details.DWG. SS-03 (REV 01-07). 3/2/2009 11:03:02 AM

ALL PRECAST MANHOLE SECTIONS
SHALL CONFORM TO ASTM C-478
OR AASHTO M-199

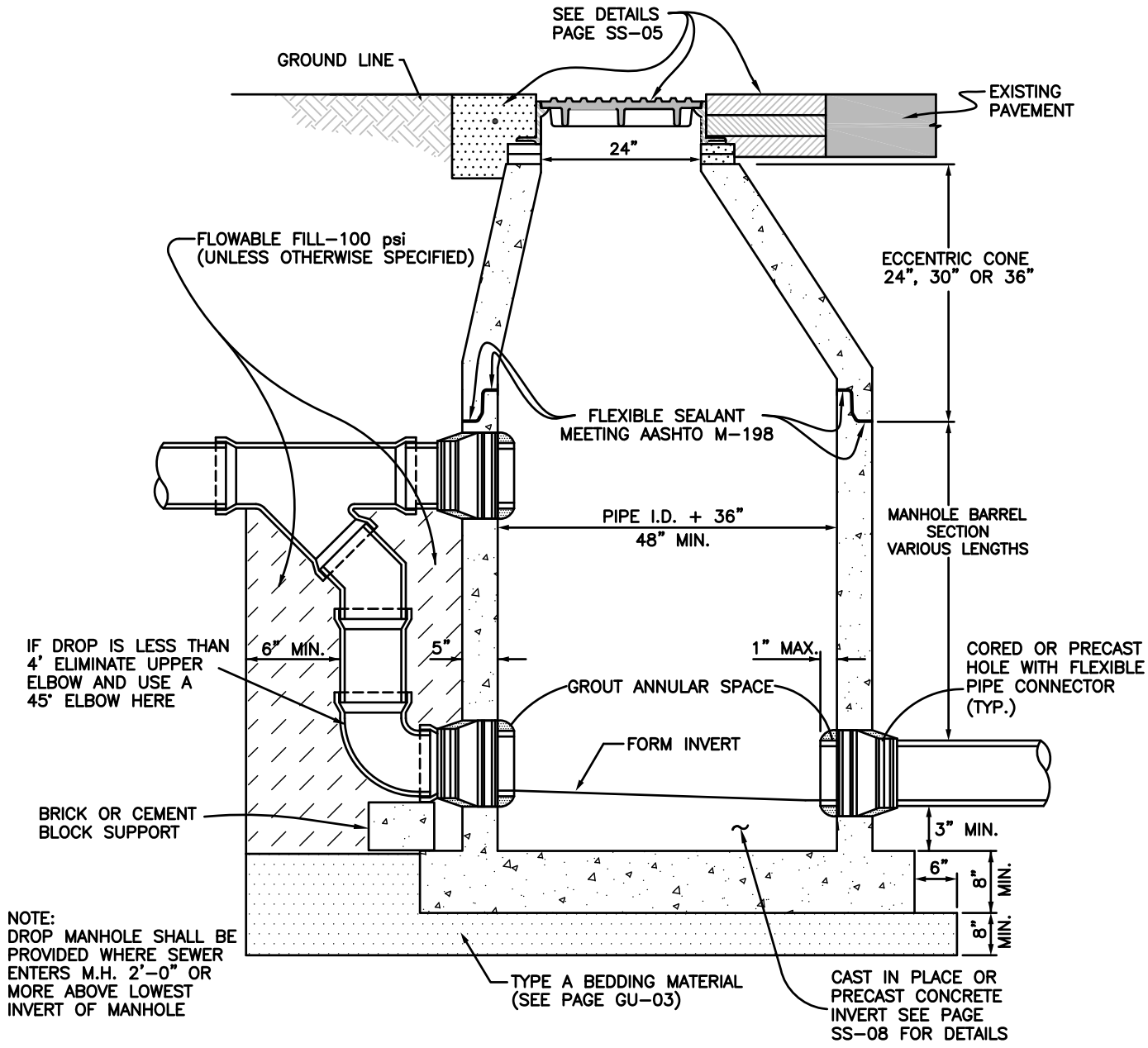

NOTE:
DROP MANHOLE SHALL BE
PROVIDED WHERE SEWER
ENTERS M.H. 2'-0" OR
MORE ABOVE LOWEST
INVERT OF MANHOLE

NOTE: THE INTERIOR SURFACES OF ALL DROP
MANHOLES SHALL BE EPOXY COATED IN
ACCORDANCE WITH SECTION 102 OF THE CITY'S
STANDARD SPECIFICATIONS FOR CONSTRUCTION OF
UNDERGROUND UTILITIES.

DROP MANHOLE

DEPARTMENT OF PUBLIC WORKS AND PLANNING ENGINEERING DIVISION CITY OF GRAND JUNCTION, COLORADO	STANDARD SANITARY SEWER DETAIL	APPROVED: <u>DN</u> REVISED: <u>DEC. 2009</u> DRAWN: <u>JAH</u>	PAGE SS-04
---	-----------------------------------	---	---------------

N:\Cadd\CITY STANDARDS\STANDARD DRAWING DETAILS\2009 Revisions\2008-Sanitary Sewer Details.DWG. SS-04 (REV 12-09), 12/17/2009 12:31:13 PM

ADJUST MANHOLE RING AND COVER TO MATCH SLOPE OF PAVEMENT. TOP OF KNOBS ON MANHOLE LID SHALL BE FLUSH WITH, OR NO MORE THAN 1/8" BELOW TOP OF PAVEMENT.

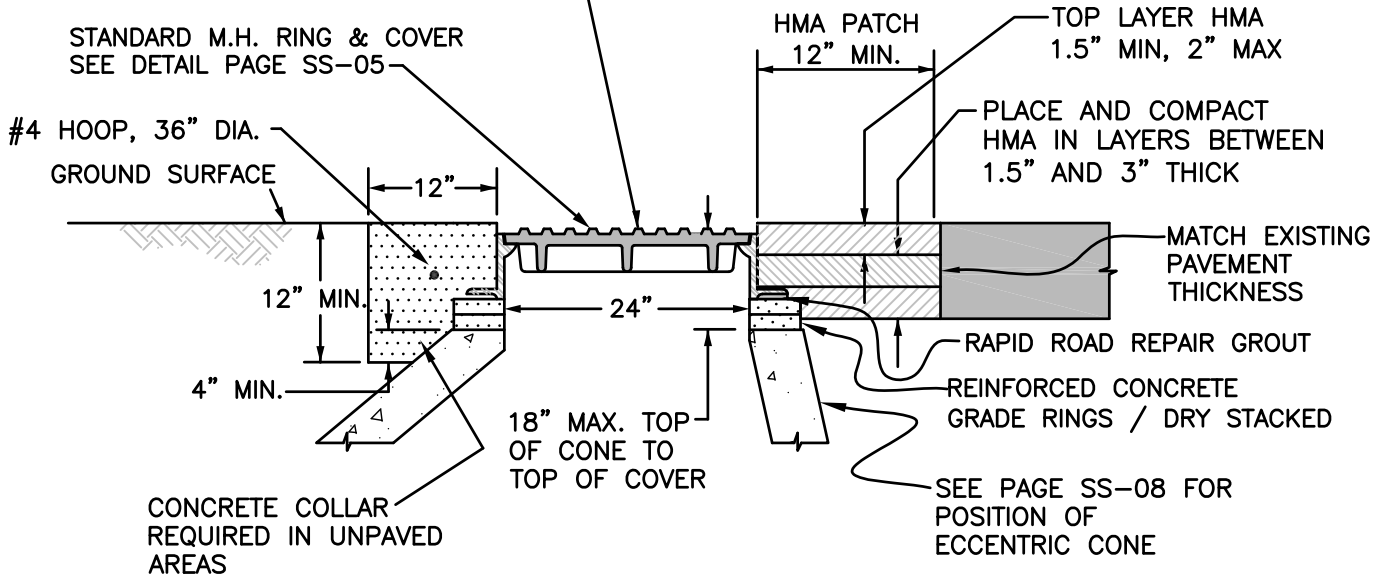

DETAIL A

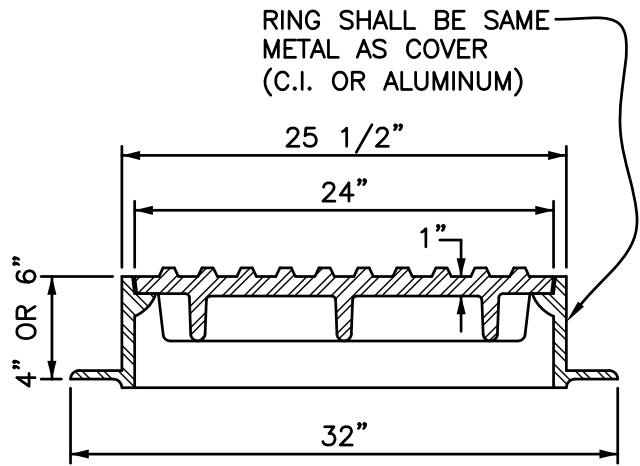
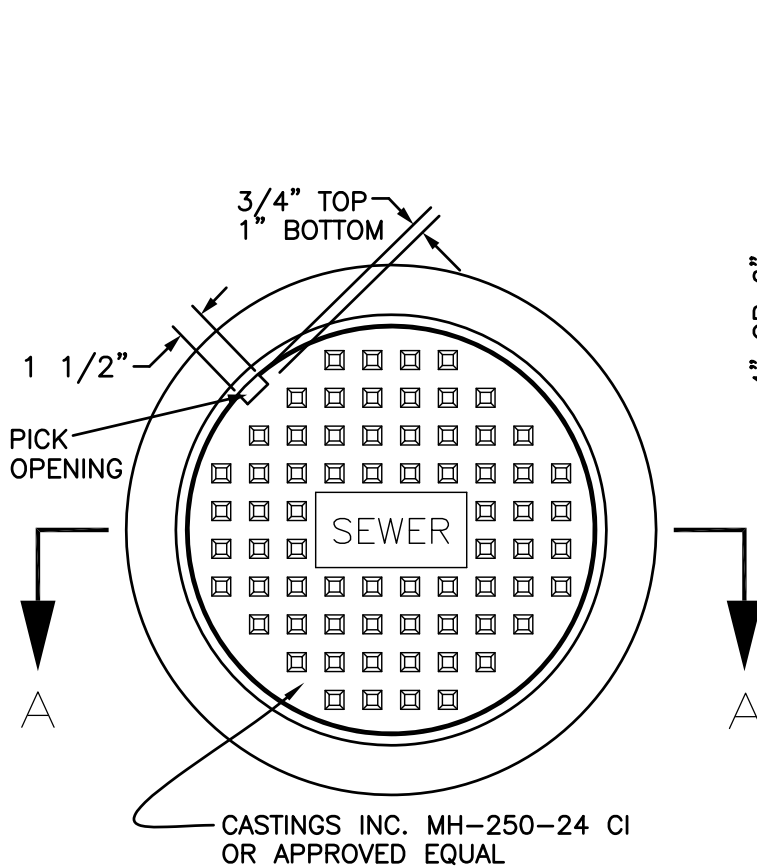

SECTION A-A

NOTE:
FOR SEWER MANHOLES LOCATED IN SIDEWALK OR OTHER PEDESTRIAN WAY USE CASTINGS INC. MH-250-24D CI (CHECKER PATTERN LID)

STANDARD MANHOLE RING AND COVER

DEPARTMENT OF PUBLIC WORKS AND PLANNING
ENGINEERING DIVISION
CITY OF GRAND JUNCTION, COLORADO

STANDARD SANITARY SEWER
DETAIL

APPROVED: *SBG*
REVISED: *JUNE 2010*
DRAWN: *JAH*

PAGE
SS-05

N:\Cadd\CITY STANDARDS\STANDARD DRAWING DETAILS\2008 October Revisions\2008-Sanitary Sewer Details.DWG, SS-06 (REV 1-2009), 3/2/2009 11:04:57 AM

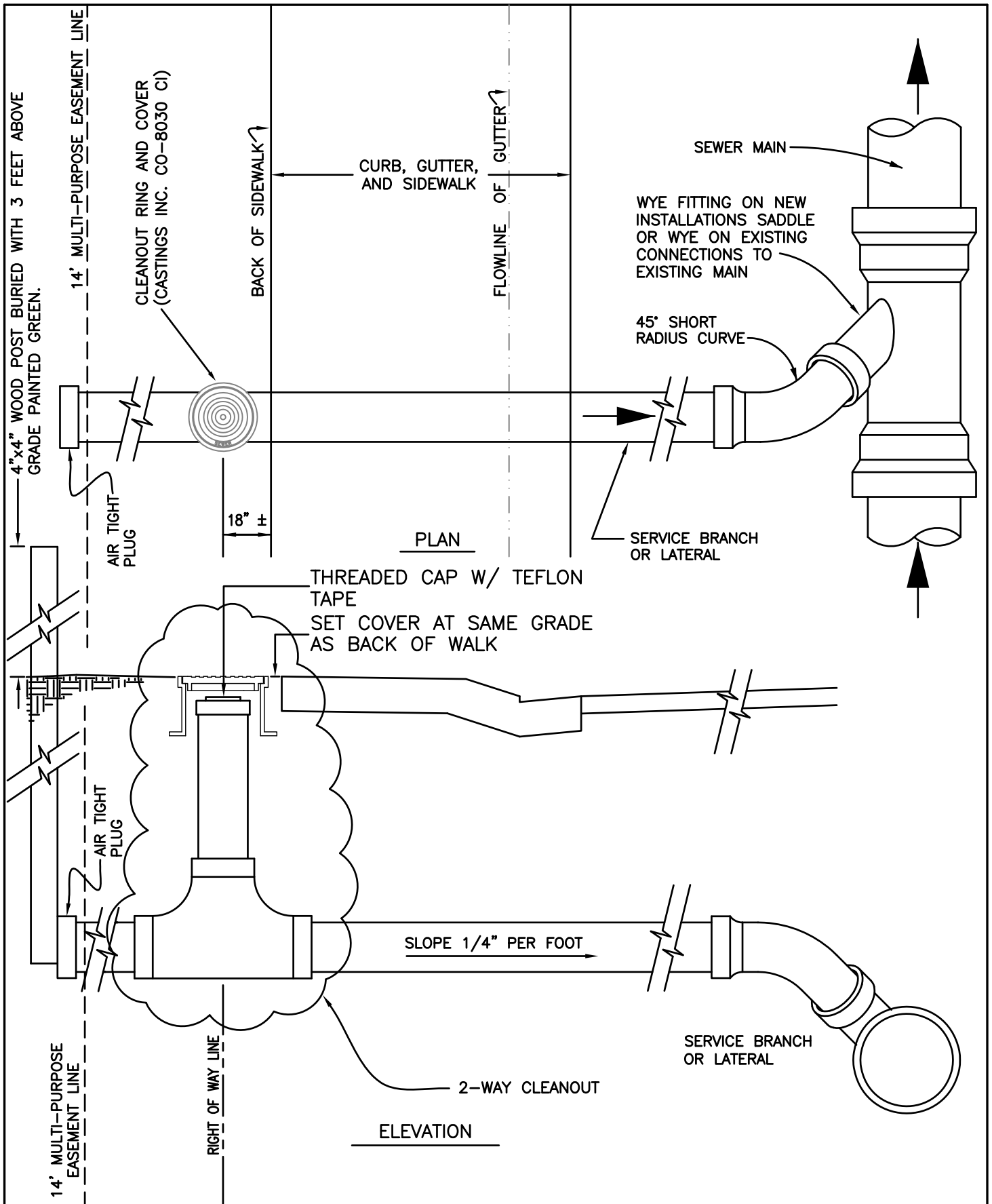

TYPICAL SERVICE "Y" CONNECTION

DEPARTMENT OF PUBLIC WORKS AND PLANNING
ENGINEERING DIVISION
CITY OF GRAND JUNCTION, COLORADO

STANDARD SANITARY SEWER SERVICE
DETAIL

APPROVED: *BG*
REVISED: *JAN 2009*
DRAWN: *TCP/DPW*

PAGE
SS-06

N:\Cadd\CITY STANDARDS\STANDARD DRAWING DETAILS\2008-October Revisions\2008-Sanitary Sewer Details.DWG, SS-07 (REV 01-07), 3/2/2009 11:05:35 AM

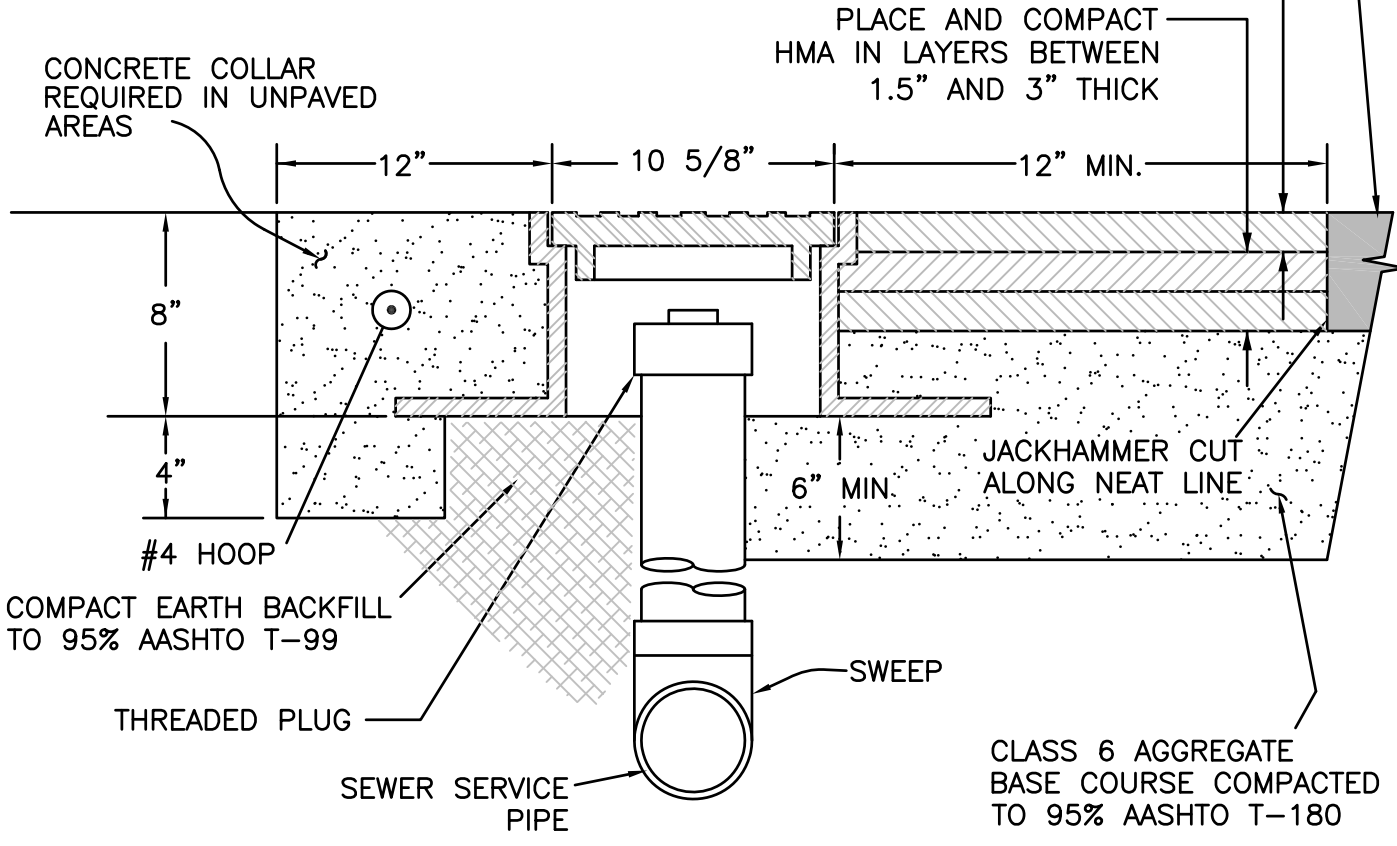
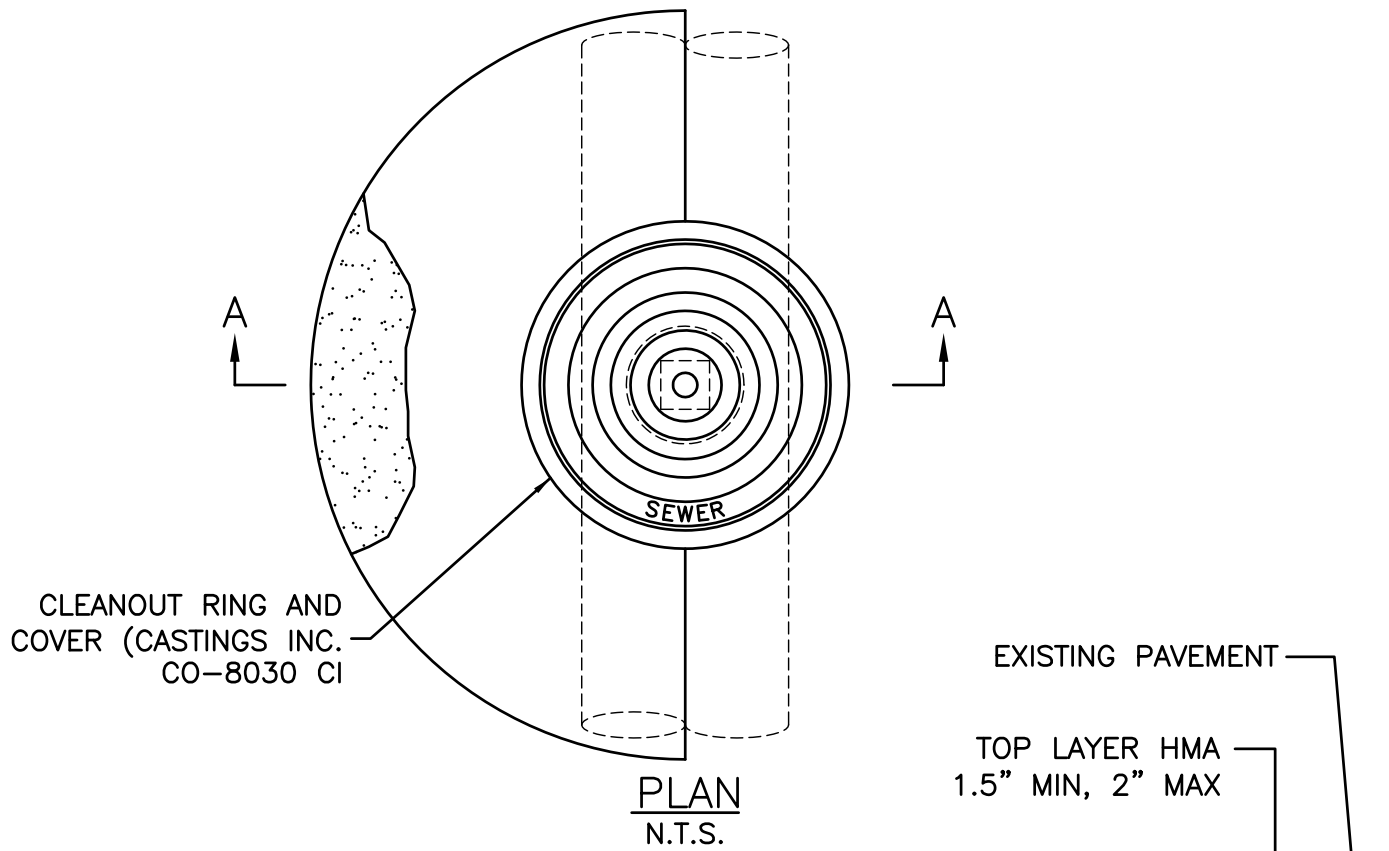

SECTION A-A
N.T.S.

SEWER SERVICE CLEANOUT WITHIN RIGHT-OF-WAY

DEPARTMENT OF PUBLIC WORKS AND PLANNING
ENGINEERING DIVISION
CITY OF GRAND JUNCTION, COLORADO

STANDARD SEWER LINE
DETAIL

APPROVED: DN
REVISED: FEB 2007
DRAWN: TLT

PAGE
SS-07

GROUT FOR PIPE CONNECTIONS SHALL BE ALL-CRETE (5 OR 20 MINUTE SET) MANUFACTURED BY FOSROC INC. OR AN APPROVED SUBSTITUTE.

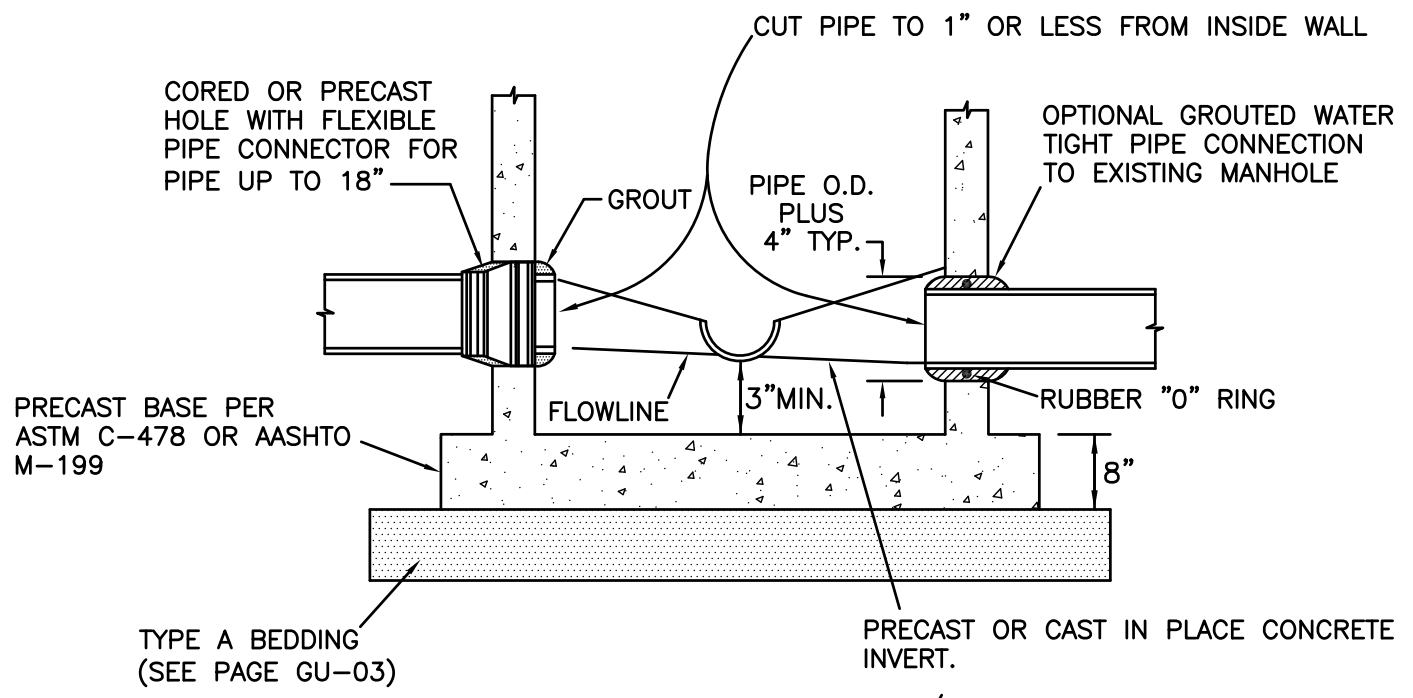

PRECAST MANHOLE BASE/TIE TO EXISTING MANHOLE WITHOUT BOOT

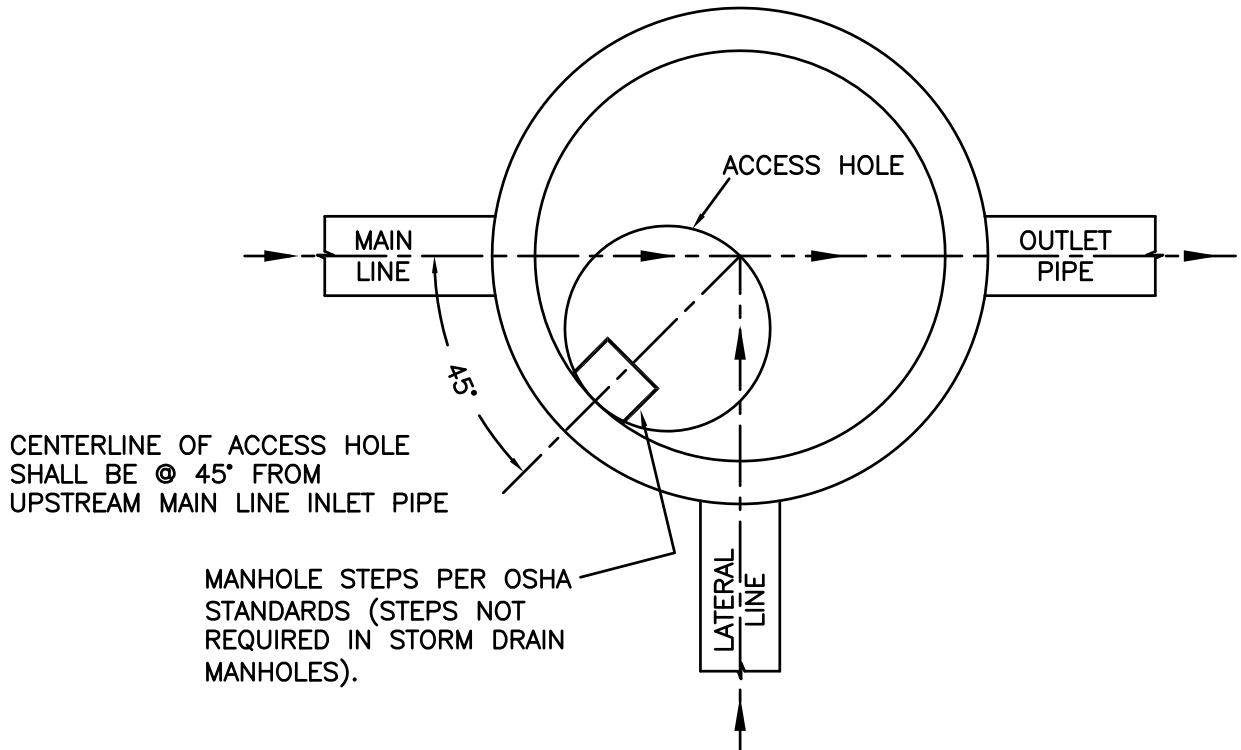

MANHOLE ACCESS LOCATION

PRECAST MANHOLE BASE, PIPE CONNECTIONS AND ACCESS HOLE LOCATION

DEPARTMENT OF PUBLIC WORKS AND PLANNING ENGINEERING DIVISION CITY OF GRAND JUNCTION, COLORADO	STANDARD SANITARY SEWER DETAIL	APPROVED: <u>DN</u> DATE: <u>JULY 2005</u> DRAWN: <u>CM</u>	PAGE SS-08
---	-----------------------------------	---	---------------

N:\Cadd\CITY STANDARDS\STANDARD DRAWING DETAILS\2008 October Revisions\2008-Sanitary Sewer Details.DWG, SS-08, 3/2/2009 11:06:11 AM

- W-01 Water Meter Location Horizontal / Attached Sidewalk
- W-02 Water Meter Location Horizontal / Detached Sidewalk
- W-03 Water Meter Pit Installation / Vertical
- W-04 Fire Line and Domestic Service Line
- W-05 1-1/2" and 2" Meter and Vault
- W-06 4" and 6" Meter and Vault
- W-07 Thrust Block Details
- W-08 Table for Concrete Thrust Blocking
- W-09 Fire Hydrant
- W-10 Valve Box Assembly
- W-11 Air Release Valve
- W-12 Lowering for Utility Crossing – 12" or Smaller Water Line
- W-13 Field Installation Polyethylene AWWA C-105 Method "A"
- W-14 Valve Operation
- W-15 Standard Sprinkler Tap Detail
- W-16 Ridges Irrigation Service Detail
- W-17 Typical Domestic Water Flowline and Public or Private Utility Crossing.
- W-18 Tracing Wire Splice Detail

TABLE OF CONTENTS – WATERLINE DETAILS

DEPARTMENT OF PUBLIC WORKS AND PLANNING ENGINEERING DIVISION CITY OF GRAND JUNCTION, COLORADO	STANDARD WATERLINE DETAILS	APPROVED: <u>DN</u> REVISED: <u>FEB. 2007</u> DRAWN: <u>TLT</u>	PAGE W-00
---	-------------------------------	---	--------------

N:\Cadd\CITY STANDARDS\STANDARD DRAWING DETAILS\2008-October Revisions\2008-Water Details.DWG, W-01, 3/2/2009 11:10:53 AM

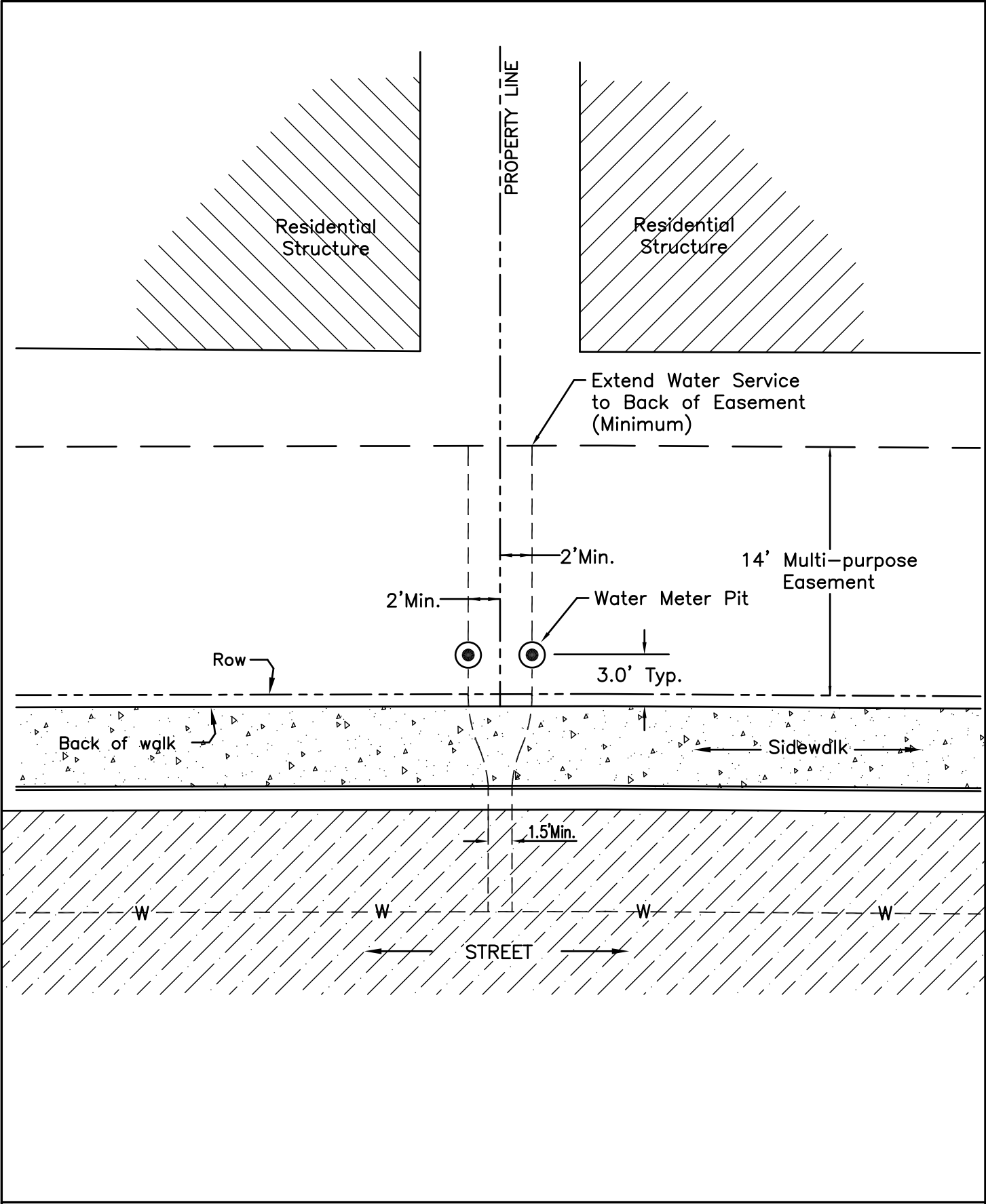

WATER METER LOCATION HORIZONTAL / ATTACHED SIDEWALK

DEPARTMENT OF PUBLIC WORKS AND PLANNING ENGINEERING DIVISION CITY OF GRAND JUNCTION, COLORADO	STANDARD WATERLINE DETAIL	APPROVED: <u>DN</u> DATE: <u>JULY 2005</u> DRAWN: <u>CM</u>	PAGE W-01
---	------------------------------	---	--------------

N:\Cadd\CITY STANDARDS\STANDARD DRAWING DETAILS\2008-Water Details.DWG, W-02, 3/2/2009 12:18:50 PM

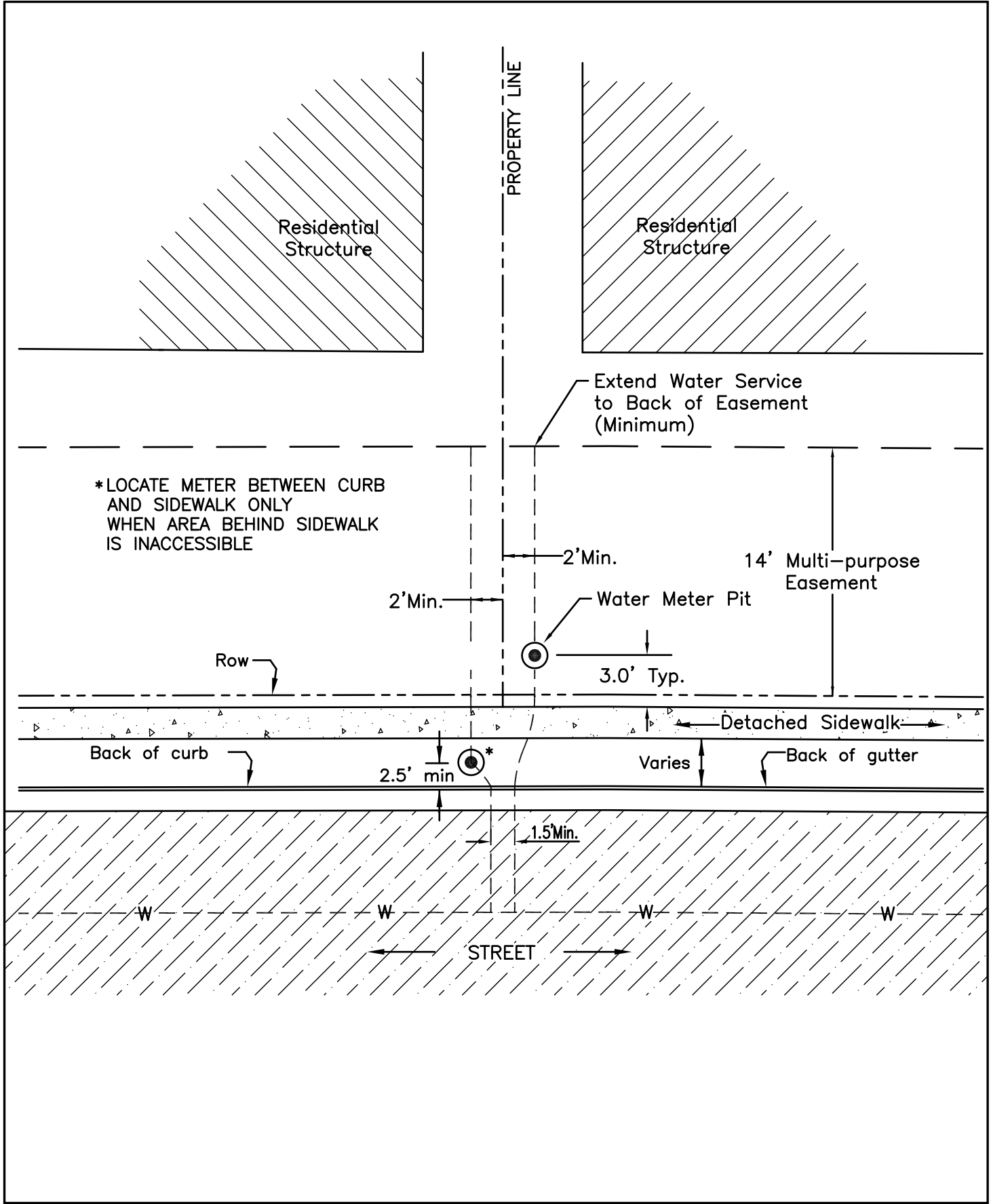

WATER METER LOCATION HORIZONTAL / DETACHED SIDEWALK

DEPARTMENT OF PUBLIC WORKS AND PLANNING ENGINEERING DIVISION CITY OF GRAND JUNCTION, COLORADO	STANDARD WATERLINE DETAIL	APPROVED: <u>DN</u> DATE: <u>JULY 2005</u> DRAWN: <u>CM</u>	PAGE W-02
---	------------------------------	---	--------------

SET TOP OF METER LID TO MATCH FINISHED GRADE

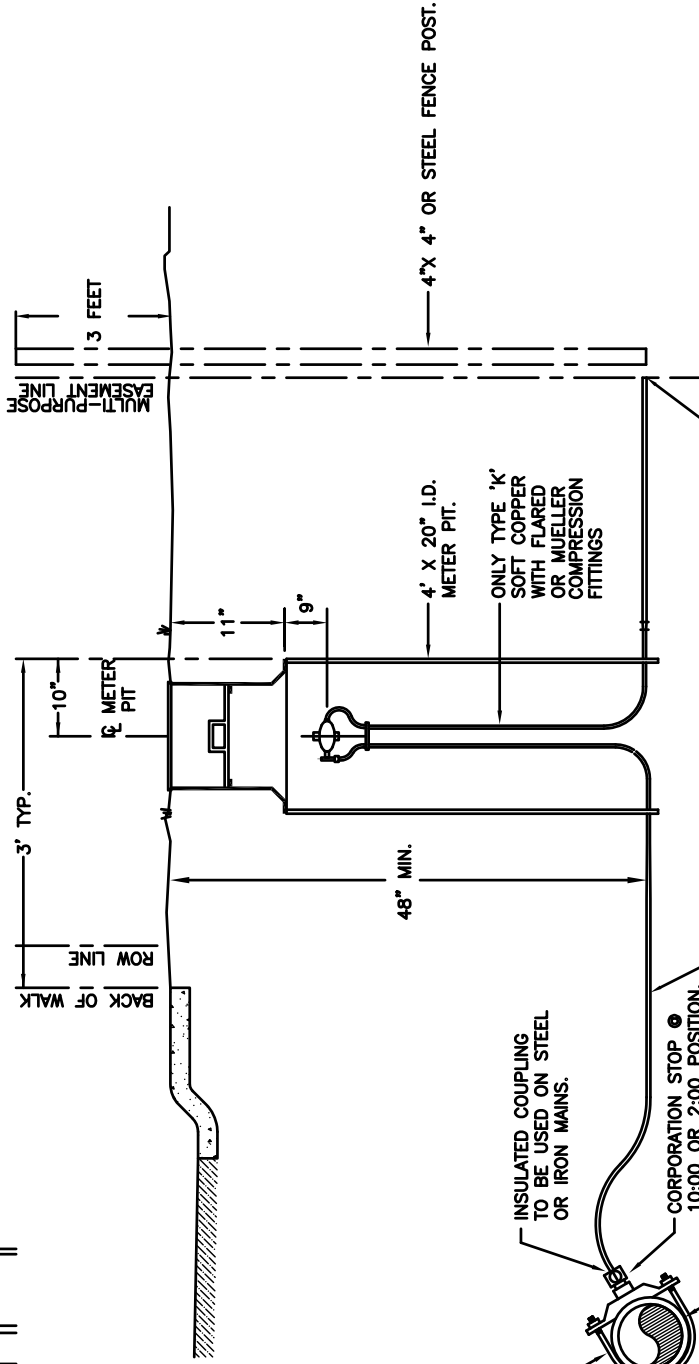
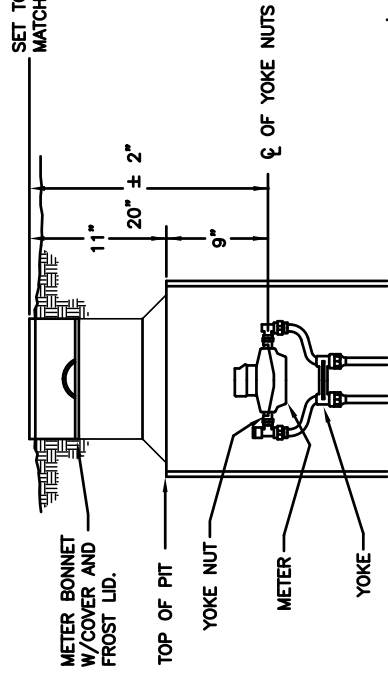

PLUG WATER SERVICE & CONDUIT AT EASEMENT LINE. PLUMBING CONTRACTOR TO COMPLETE SERVICE TO RESIDENCE. NO PVC MALE ADAPTERS ALLOWED. MARK WITH 4" X 4" OR STEEL FENCE POST PAINTED BLUE. POST SHALL BE BURIED SO THAT 3 FEET EXTENDS ABOVE GRADE.

SERVICE PIPE SHALL BE TYPE K COPPER FROM MAIN THROUGH METER PIT.

WATER METER INSTALLATION / VERTICAL

DEPARTMENT OF PUBLIC WORKS AND PLANNING
 ENGINEERING DIVISION
 CITY OF GRAND JUNCTION, COLORADO

STANDARD WATERLINE
 DETAIL

APPROVED: DN
 REV: JULY 2005
 DRAWN: CM

PAGE
 W-03

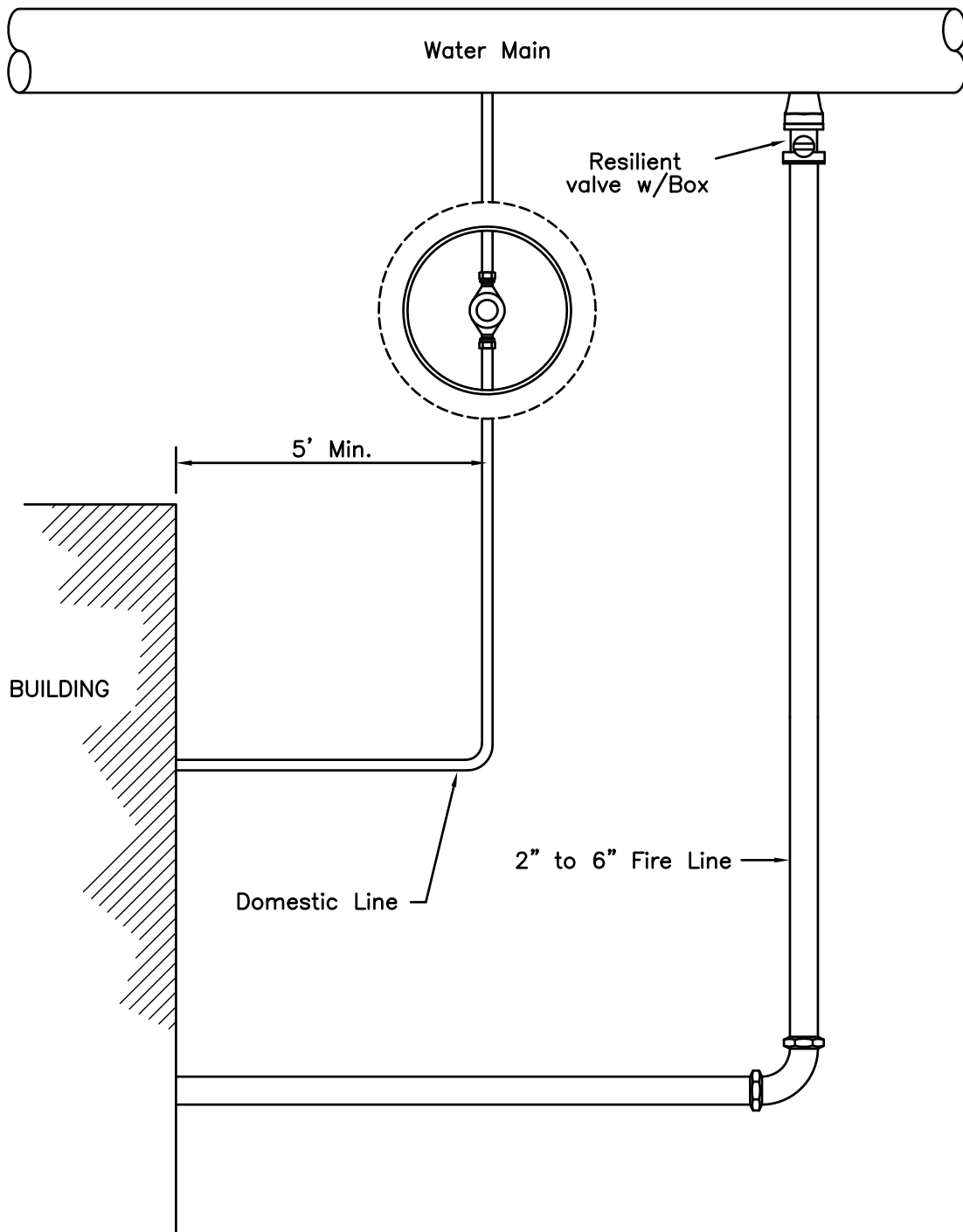

NOTES:

1. Service lines: All connections to be flared or Mueller compression.
2. Fire Lines: Backflow preventer on inside of building.
3. All services 3/4" to 2" shall be Type K copper only.
4. All 3" service lines shall be CL 200 psi PVC
5. All services 4" and larger shall be C-900.

FIRE LINE AND DOMESTIC SERVICE LINE

DEPARTMENT OF PUBLIC WORKS AND PLANNING
ENGINEERING DIVISION
CITY OF GRAND JUNCTION, COLORADO

STANDARD WATERLINE
DETAIL

APPROVED: DN
DATE: FEB. 2005
DRAWN: TCP/DPW

PAGE
W-04

Type K-copper service & flared or Mueller compression fittings only.

NOTE:

City crews will set vault and meter.

Vault Notes:
If vault is set where exposed to traffic, then walls shall be 6" and vault set on 2-12" x 9" x 48" reinforced concrete grade beams, otherwise 4" may be used. Wall penetrations for service lines shall not exceed 3" x 10".

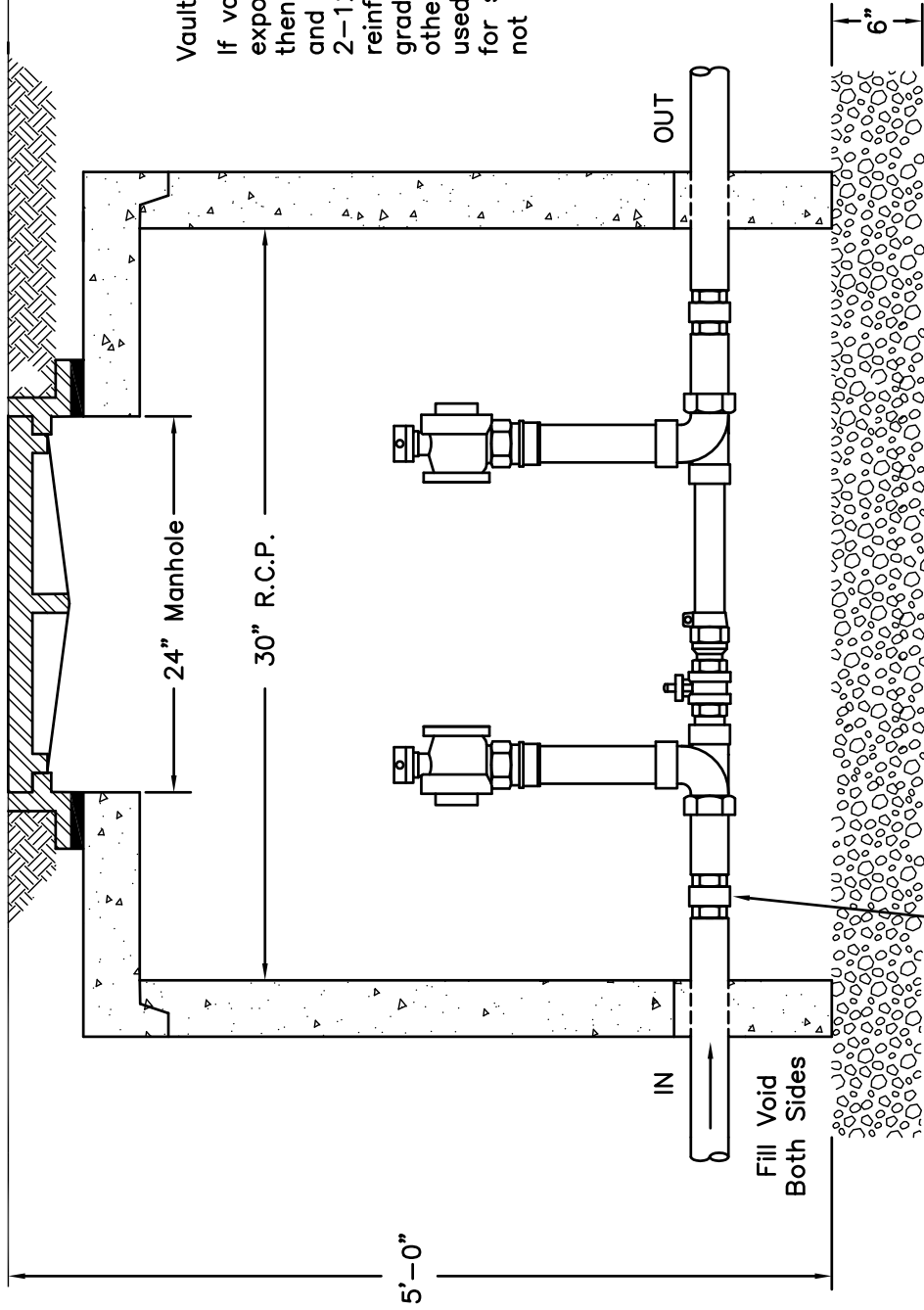

Fill Void Both Sides

Hi-Pressure Areas will require PRV.

PRV type Series 25AUB Watts

1-1/2" AND 2" METER AND VAULT

DEPARTMENT OF PUBLIC WORKS AND PLANNING
ENGINEERING DIVISION
CITY OF GRAND JUNCTION, COLORADO

STANDARD WATERLINE
DETAIL

APPROVED: DN
DATE: FEB. 2005
DRAWN: TCP/DPW

PAGE
W-05

- NOTE:**
 City crews will set vault and meter.
- For meters 4" and larger, meter support shall be a 8" x 8" x 12" concrete block set in gravel. Vault cover may be sectional (3 piece) to facilitate installation and removal. Valves to be Resilient seated valves.
 - Vault must withstand H-20 loading for placement within traffic areas.

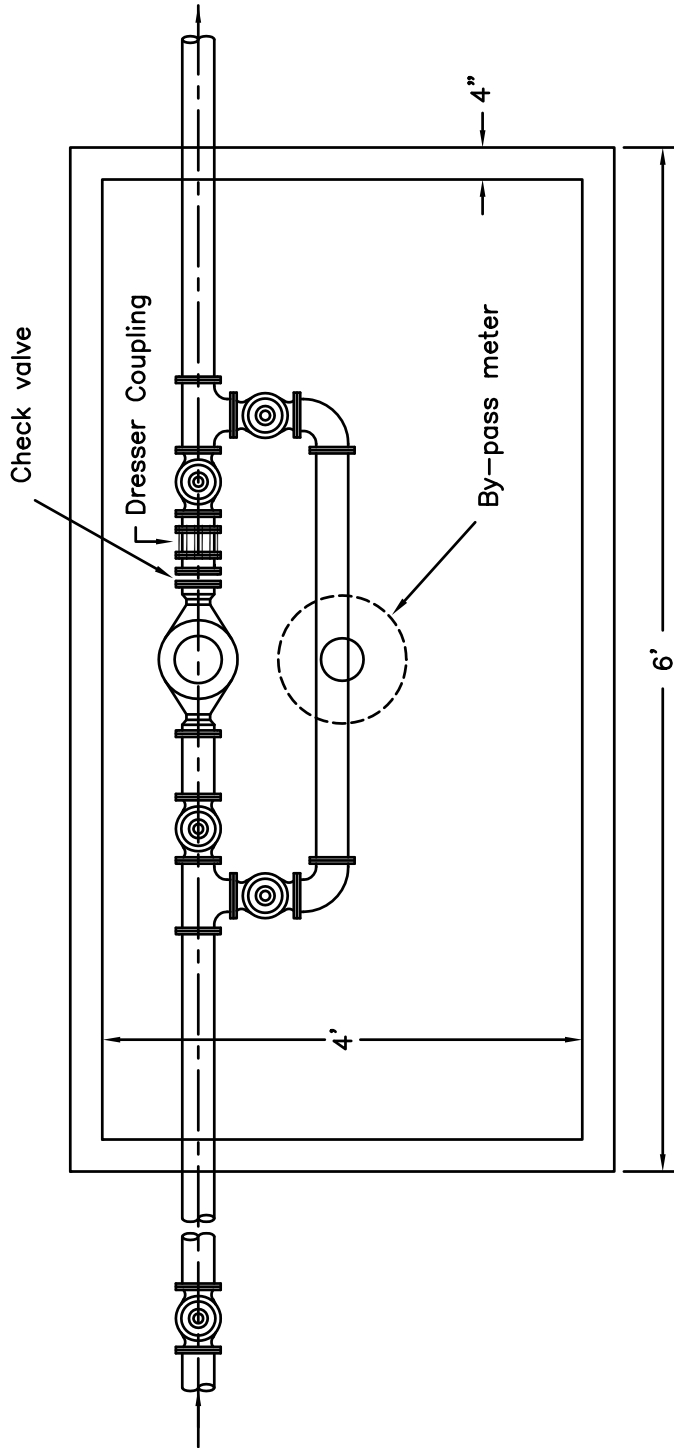

4" AND 6" METER AND VAULT

DEPARTMENT OF PUBLIC WORKS AND PLANNING
 ENGINEERING DIVISION
 CITY OF GRAND JUNCTION, COLORADO

STANDARD WATERLINE
 DETAIL

APPROVED: DN
 DATE: FEB. 2005
 DRAWN: TCP/DPW

PAGE
 W-06

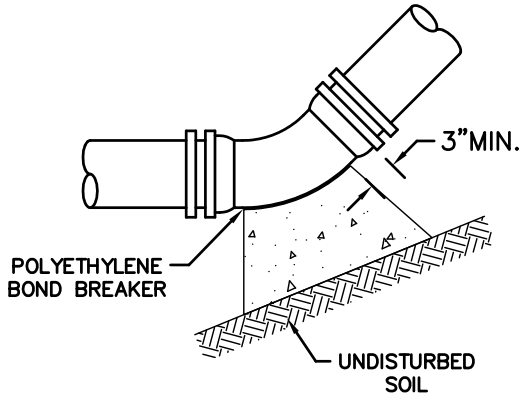

TYPICAL BEND
11 1/4', 22 1/2', 45', 90'

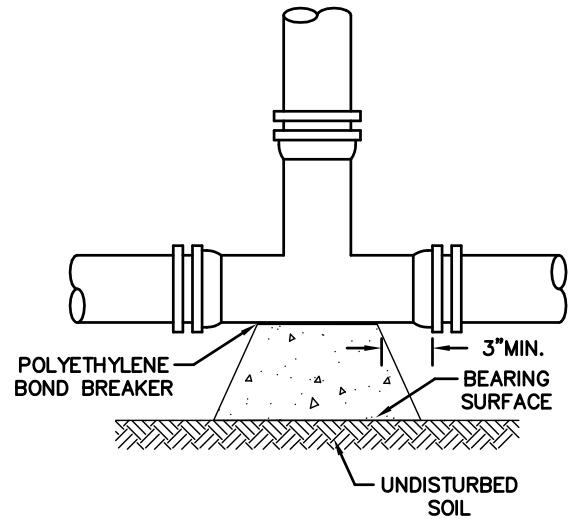

TEE

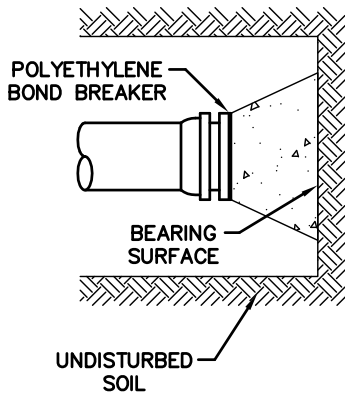

DEAD END

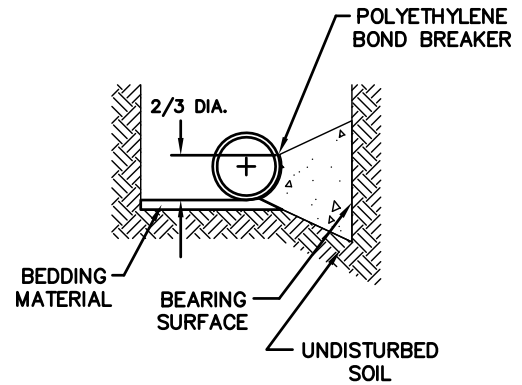

TYPICAL CROSS-SECTION

GENERAL NOTES:

1. All fittings to be wrapped with 8 mil polyethylene.
2. Pipe installed under conditions different from those normally encountered shall require thrust blocks designed for those particular conditions.
3. Thrust blocks on pipe larger than 12 inches diameter shall be designed for conditions existing at the installation site.
4. All thrust blocks to be 3000 p.s.i. concrete.
5. Mechanical restraints are to be installed in accordance with City Standards for Construction of Underground Utilities Section 104.3d.

THRUST BLOCK DETAILS

DEPARTMENT OF PUBLIC WORKS AND PLANNING
ENGINEERING DIVISION
CITY OF GRAND JUNCTION, COLORADO

STANDARD WATERLINE
DETAIL

APPROVED: DN
DATE: FEB. 2005
DRAWN: TCP/DPW

PAGE
W-07

BEARING AREAS (IN SQ. FT.)

SIZE	BENDS				TEES, DEAD ENDS, AND CROSS w DEAD END BRANCHES
	90°	45°	22 1/2°	11 1/2°	
3	1.0	0.6	0.3	0	0.7
4	1.8	1.0	0.5	0	1.3
6	4.0	2.2	1.1	0	2.8
8	7.1	3.8	2.0	1.0	5.0
10	11.1	6.0	3.0	1.5	7.8
12	16.0	8.6	4.4	2.2	11.3
14	21.7	11.8	6.0	3.0	15.4
15	25.0	13.5	7.0	3.5	17.6
16	28.4	15.3	8.0	4.0	20.0
18	36.0	19.4	10.0	5.0	25.4
20	44.2	24.0	12.2	6.1	31.4
21	49.0	26.5	13.5	6.8	34.6
22	54.0	29.0	14.8	7.4	38.0
24	64.0	34.5	17.7	8.8	45.0
30	100.0	54.0	27.6	13.8	71.0
36	144.0	78.0	40.0	20.0	102.0

NOTE: TEE SIZE IS BRANCH SIZE.

AREAS GIVEN IN TABLE ARE BASED UPON INTERNAL STATIC PRESSURE OF 100 P.S.I. AND SOIL BEARING CAPACITY OF 1,000 lbs. PER SQ. FT.

BEARING AREAS FOR ANY PRESSURE AND SOIL BEARING CAPACITY MAY BE OBTAINED BY MULTIPLYING TABULATED VALUES BY A CORRECTION FACTOR "F"

$$F = \frac{\text{ACTUAL SPECIFIED TEST PRESSURE IN HUNDREDS OF lbs.}}{\text{ACTUAL SOIL BEARING CAPACITY IN THOUSANDS OF lbs.}}$$

SOIL BEARING CAPACITIES SHALL BE DETERMINED BY THE ENGINEER

ALL WATER LINE PLANS SHALL CONTAIN THE FOLLOWING TABLE, WITH THE VALUES FILLED IN BY THE ENGINEER:

SOIL BEARING CAPACITY - _____ LBS/SQ. FT. TEST PRESSURE - _____ P.S.I. BEARING AREA MULTIPLIER (F) - _____
--

TABLE FOR CONCRETE THRUST BLOCKING

DEPARTMENT OF PUBLIC WORKS AND PLANNING ENGINEERING DIVISION CITY OF GRAND JUNCTION, COLORADO	STANDARD WATERLINE DETAIL	APPROVED: <u>DN</u> DATE: <u>FEB. 2005</u> DRAWN: <u>TOP/DPW</u>	PAGE W-08
---	------------------------------	--	--------------

N:\Cadd\CITY STANDARDS\STANDARD DRAWING DETAILS\2008 October Revisions\2008-Water Details.DWG, W-08, 3/2/2009 12:30:21 PM

MUELLER CENTURIAN
200 OR APPROVED
SUBSTITUTE.

2' MIN.
3' MAX.

18" MIN.
22" MAX.

GROUND LINE

1"±

NUT AND BOLT WITH WIRE
SECURED BY SILVER SOLDER

PVC CAP, GLUED

3/4" PVC

#10 TRACING WIRE

VALVE BOX
AND
EXTENSION

DETAIL "A"

EDGE OF SIDEWALK

1"± ABOVE
BURY LINE

BURY LINE
MARK

DO NOT WRAP HYDRANT BARREL
& SHOE WITH POLYETHYLENE

48"
MINIMUM

INSTALL #10 TRACING
WIRE TO EACH HYDRANT
BASE. SEE DETAIL "A"

FLANGED X MECHANICAL
JOINT, 6" GATE VALVE *

3-WAY DIRECT BURY
WIRE CONNECTOR FOR
LOW VOLTAGE
APPLICATION

DO NOT OBSTRUCT WEEPHOLES

#10 TRACING WIRE

JOINT RESTRAINT**

6 INCH C900 PVC

14 IN.

METAL PIPE, VALVES, FITTINGS AND
APPURTENANCES SHALL BE WRAPPED
WITH 8 MIL POLYETHYLENE MATERIAL
PRIOR TO BACKFILLING.

THRUST BLOCK

WATER MAIN

MECHANICAL OR SLIP JOINT
X FLANGED TEE OR
FLANGED TAPPING SADDLE*

3/4" WASHED ROCK
1/4 CU. YD. MIN.
1 1/2" MAX. STONE SIZE

24 INCH MIN.

DRY THRUST BLOCKS (4" TO 6" THICK)
PER TABLE ON PAGE W-08
1/4 CU. YD MIN.

* ALT.-SWIVEL TEE AND MJ VALVE

**THRUST RESTRAINT SHALL BE PROVIDED BY DRY THRUST BLOCKS AND
THE USE OF JOINT RESTRAINTS FROM THE TEE TO THE HYDRANT.

FIRE HYDRANT

DEPARTMENT OF PUBLIC WORKS AND PLANNING
ENGINEERING DIVISION
CITY OF GRAND JUNCTION, COLORADO

STANDARD WATERLINE
DETAIL

APPROVED: DN
DATE: FEB. 2006
DRAWN: CM

PAGE
W-09

N:\CADD\CITY STANDARDS\STANDARD DRAWING DETAILS\2008 October Revisions\2008-Water Details.DWG, W-09, 3/2/2009 12:31:03 PM

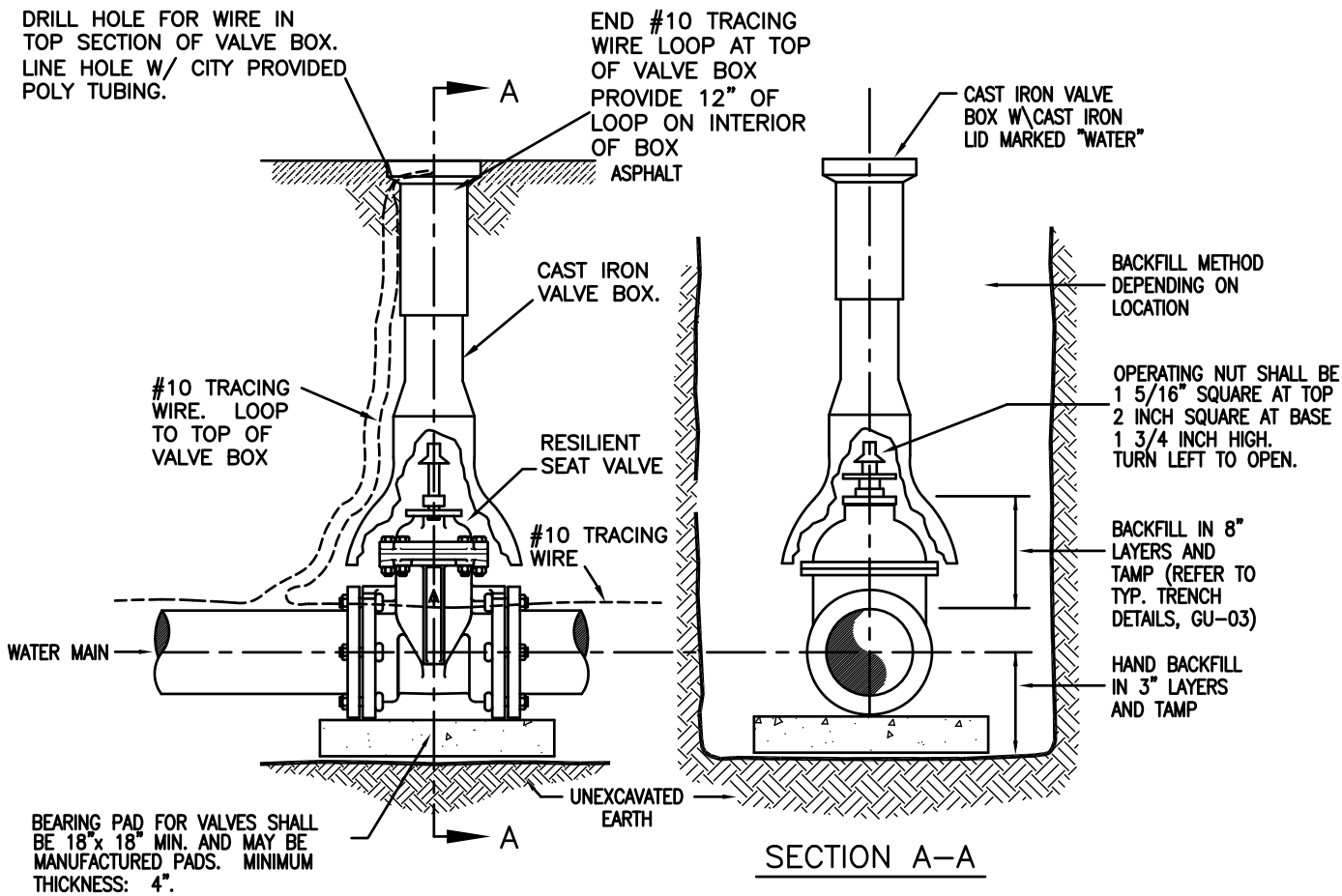

ALL VALVES TO BE RESILIENT SEAT, EPOXY COATED INSIDE AND OUT AND 8 MIL POLY WRAPPED PER CITY OF GRAND JUNCTION AND AWWA SPECS.

ALL VALVE BOXES TO BE OF CAST IRON CONSTRUCTION, TWO PIECE SLIDE CASING ADJUSTABLE DESIGN PER CITY OF GRAND JUNCTION SPECS.

ALL PACKING BOLTS AND VALVE BONNET BOLTS SHALL BE STAINLESS STEEL. ALL BOLTS FOR MECHANICAL JOINTS SHALL BE COR-BLUE OR APPROVED EQUAL. ALL BOLTS FOR FLANGE CONNECTIONS SHALL BE STAINLESS STEEL BOLTS COATED WITH ANTI-SEIZE.

INSTALL TRACING WIRE IN THE SOUTHERLY MOST VALVE BOX IN EACH INTERSECTION AS SHOWN.

VALVE BOX ASSEMBLY

DEPARTMENT OF PUBLIC WORKS AND PLANNING ENGINEERING DIVISION CITY OF GRAND JUNCTION, COLORADO	STANDARD WATERLINE DETAIL	APPROVED: <u>DN</u> DATE: <u>MARCH 2010</u> DRAWN: <u>TCF/DPW</u>	PAGE W-10
---	------------------------------	---	--------------

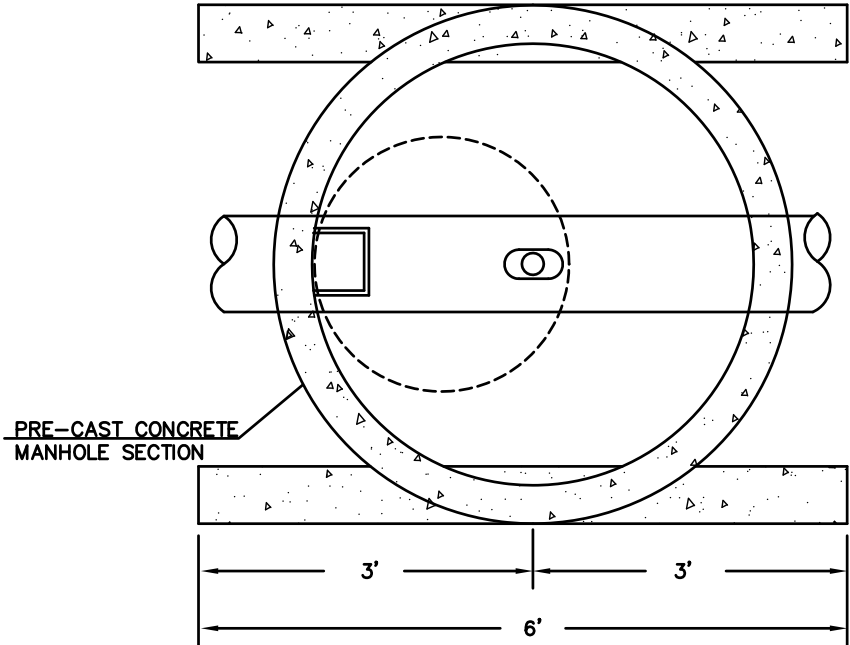

PRE-CAST CONCRETE
MANHOLE SECTION

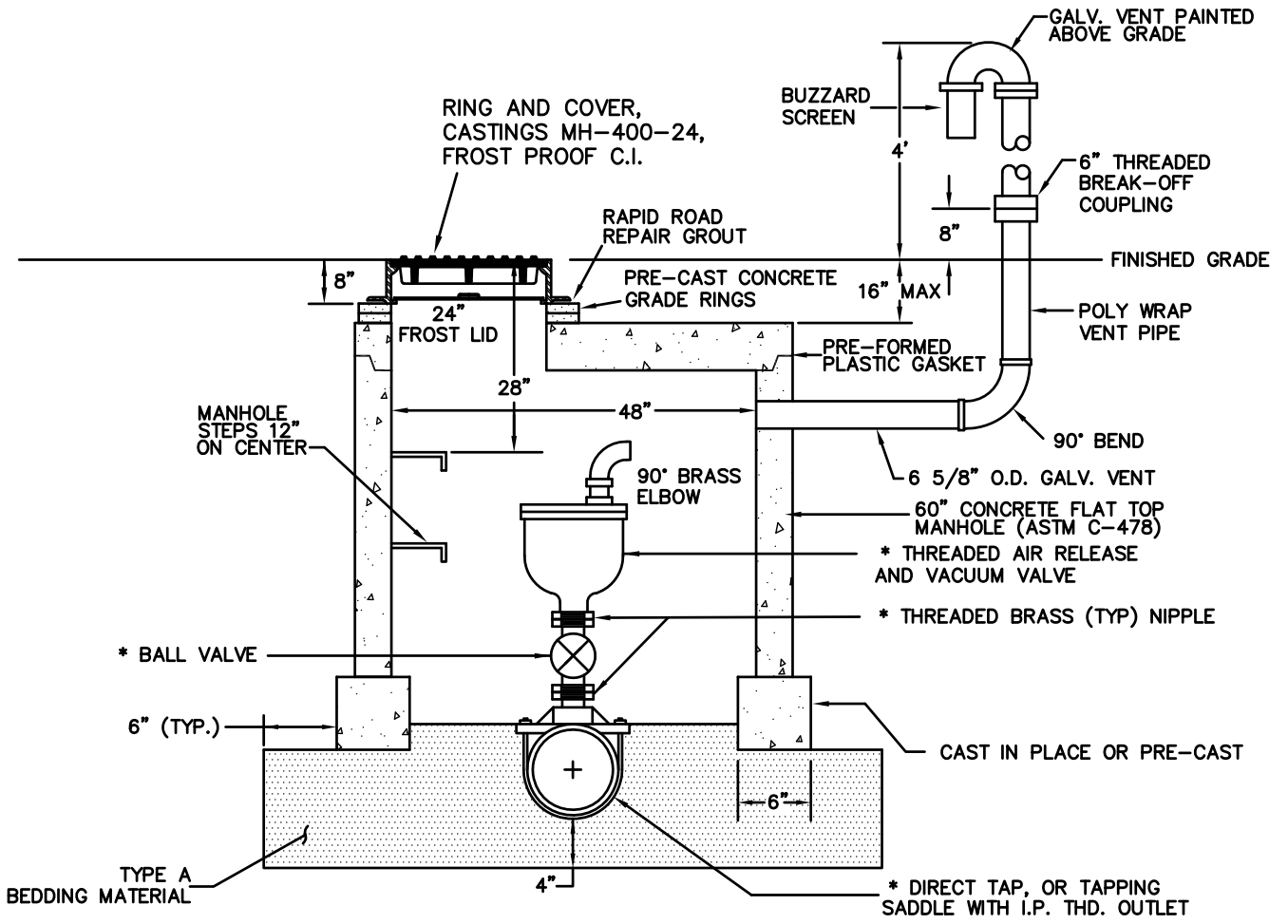

RING AND COVER, CASTINGS MH-400-24, FROST PROOF C.I.

BUZZARD SCREEN

GALV. VENT PAINTED ABOVE GRADE

6" THREADED BREAK-OFF COUPLING

FINISHED GRADE

POLY WRAP VENT PIPE

90° BEND

6 5/8" O.D. GALV. VENT

60" CONCRETE FLAT TOP MANHOLE (ASTM C-478)

* THREADED AIR RELEASE AND VACUUM VALVE

* THREADED BRASS (TYP) NIPPLE

CAST IN PLACE OR PRE-CAST

* DIRECT TAP, OR TAPPING SADDLE WITH I.P. THD. OUTLET

PRE-FORMED PLASTIC GASKET

PRE-CAST CONCRETE GRADE RINGS

16" MAX

8"

8"

24"

FROST LID

28"

48"

90° BRASS ELBOW

* BALL VALVE

6" (TYP.)

TYPE A BEDDING MATERIAL

4"

6"

MANHOLE STEPS 12" ON CENTER

RAPID ROAD REPAIR GROUT

* SIZE OF AIR VAC OR AIR RELEASE TO BE DETERMINED BY THE DESIGN ENGINEER.

AIR RELEASE VALVE

DEPARTMENT OF PUBLIC WORKS AND PLANNING
ENGINEERING DIVISION
CITY OF GRAND JUNCTION, COLORADO

STANDARD WATERLINE
DETAIL

APPROVED: DN
DATE: JAN 2009
DRAWN: TOP/DPW

PAGE
W-11

N:\Cadd\CITY STANDARDS\STANDARD DRAWING DETAILS\2008 October Revisions\2008-Water Details.DWG, W-11 (REV 1-2009), 3/2/2009 12:32:35 PM

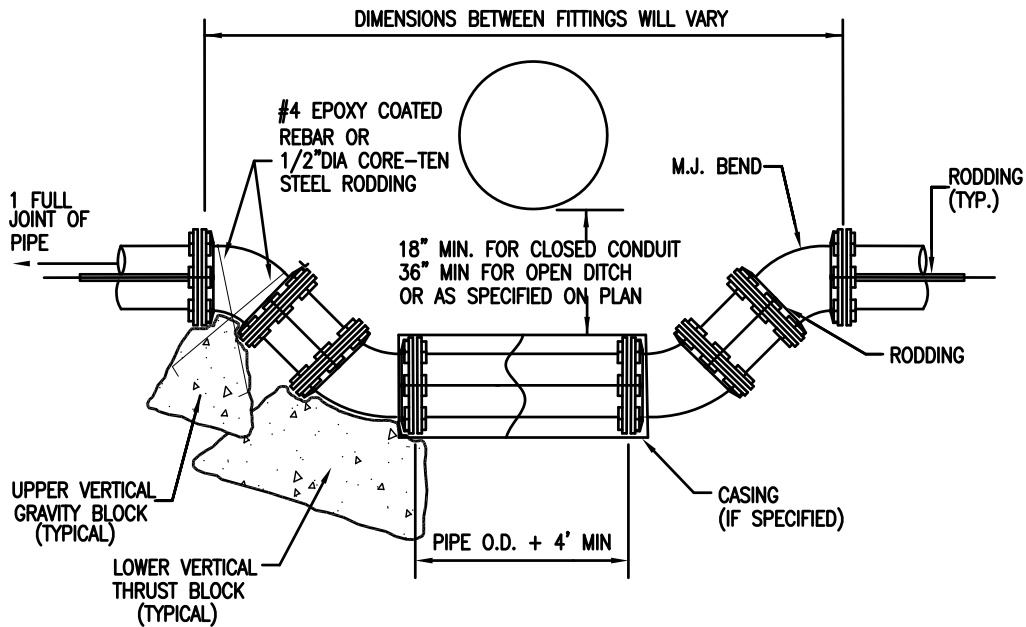

NOTES:

- 1) SIZING OF VERTICAL THRUST BLOCKS BY DESIGN ENGINEER.
- 2) WHEN RESTRAINING PIPE BY MEANS OF RODDING JOINTS, 3/4" TIE RODS, NUTS, AND WASHERS WILL BE USED AND ARE TO BE MADE OF "COR-TEN" STEEL AS PER A.S.T.M. A242. SEE TABLE 1 FOR # OF RODS REQUIRED.
- 3) ALL METALIC PIPE, FITTINGS, AND APPURTENANCES WILL BE WRAPPED IN 8 MIL POLYETHYLENE.
- 4) REQUIREMENTS FOR LARGER THAN 12" DIAMETER PIPE WILL BE DETERMINED ON A CASE BY CASE BASIS.

TABLE 1

Pipe Size	Minimum number of Tie Rods
12" and less	2

LOWERING FOR UTILITY CROSSING – 12" OR SMALLER WATERLINE

DEPARTMENT OF PUBLIC WORKS AND PLANNING
ENGINEERING DIVISION
CITY OF GRAND JUNCTION, COLORADO

STANDARD WATERLINE
DETAIL

APPROVED: DN
DATE: FEB. 2005
DRAWN: TOP/DPW

PAGE
W-12

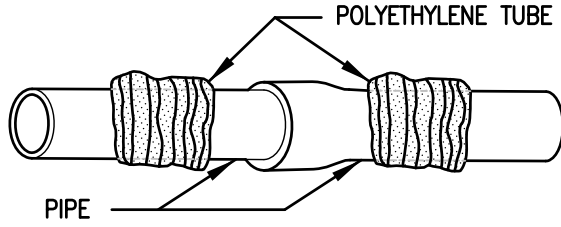

STEP 1

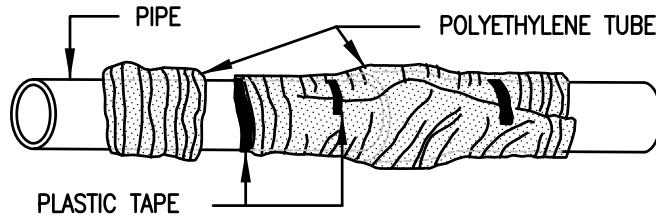

STEP 2

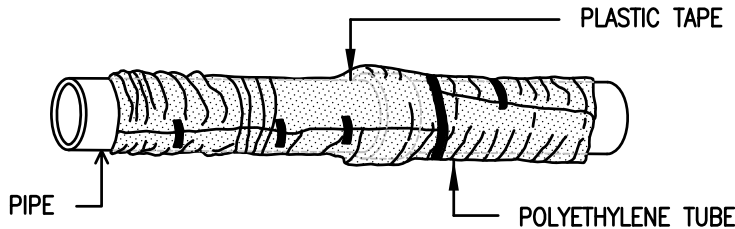

STEP 3

STEP 1- PLACE TUBE OF 8 MIL POLYETHYLENE MATERIAL ON PIPE PRIOR TO LOWERING IT INTO TRENCH.

STEP 2- PULL THE TUBE OVER THE LENGTH OF THE PIPE. TAPE TUBE TO PIPE AT JOINT. FOLD MATERIAL AROUND THE ADJACENT SPIGOT END AND WRAP WITH TAPE TO HOLD THE PLASTIC TUBE IN PLACE. EXCESS MATERIAL SHALL BE NEATLY DRAWN UP AROUND THE PIPE BARREL, FOLDED ON TOP OF PIPE AND TAPED IN PLACE.

STEP 3- OVERLAP FIRST TUBE WITH ADJACENT TUBE AND SECURE WITH PLASTIC ADHESIVE TAPE. THE POLYETHYLENE TUBE MATERIAL COVERING THE PIPE SHALL BE LOOSE. EXCESS MATERIAL SHALL BE NEATLY DRAWN UP AROUND THE PIPE BARREL, FOLDED ON TOP OF PIPE AND TAPED IN PLACE.

STEP 4- CAREFULLY BACKFILL WITH CLEAN MATERIAL THAT WILL NOT DAMAGE ENCASEMENT.

TAPS: MAKE TAPS BY WRAPPING THREE LAYERS OF COMPATIBLE TAPE AROUND THE PIPE TO COVER THE TAPPING MACHINE AREA. INSTALL CORPORATION STOP THROUGH THE TAPE AND POLYETHYLENE.

FIELD INSTALLATION POLYETHYLENE AWWA C-105 METHOD "A"

DEPARTMENT OF PUBLIC WORKS AND PLANNING
ENGINEERING DIVISION
CITY OF GRAND JUNCTION, COLORADO

STANDARD WATERLINE
DETAIL

APPROVED: DN
DATE: FEB. 2005
DRAWN: TOP/DPW

PAGE
W-13

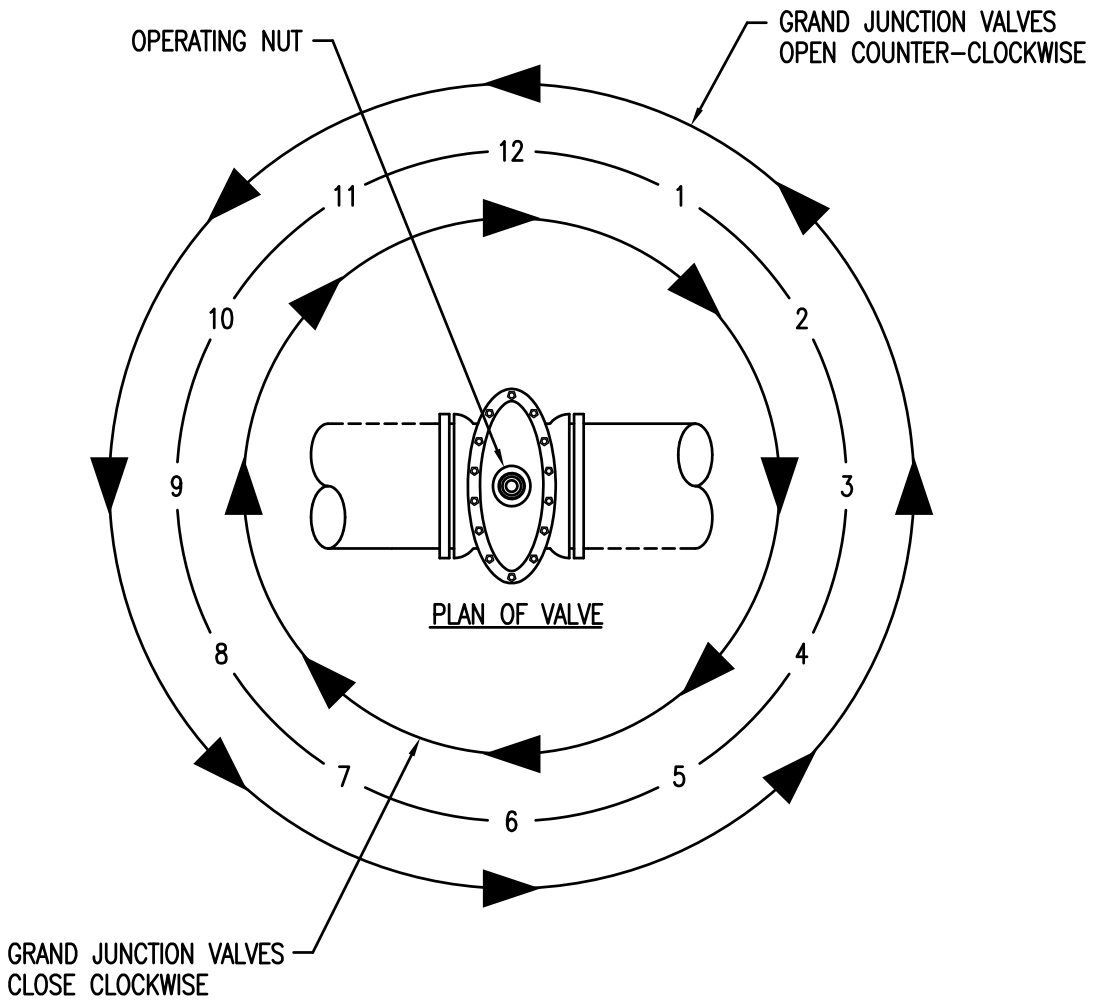

VALVE OPERATION

DEPARTMENT OF PUBLIC WORKS AND PLANNING
 ENGINEERING DIVISION
 CITY OF GRAND JUNCTION, COLORADO

STANDARD WATERLINE
 DETAIL

APPROVED: DN
 DATE: FEB. 2005
 DRAWN: TCP/DPW

PAGE
 W-14

N:\Cadd\CITY STANDARDS\STANDARD DRAWING DETAILS\2008-October Revisions\2008-Water Details.DWG, W-15, 3/2/2009 12:35:42 PM

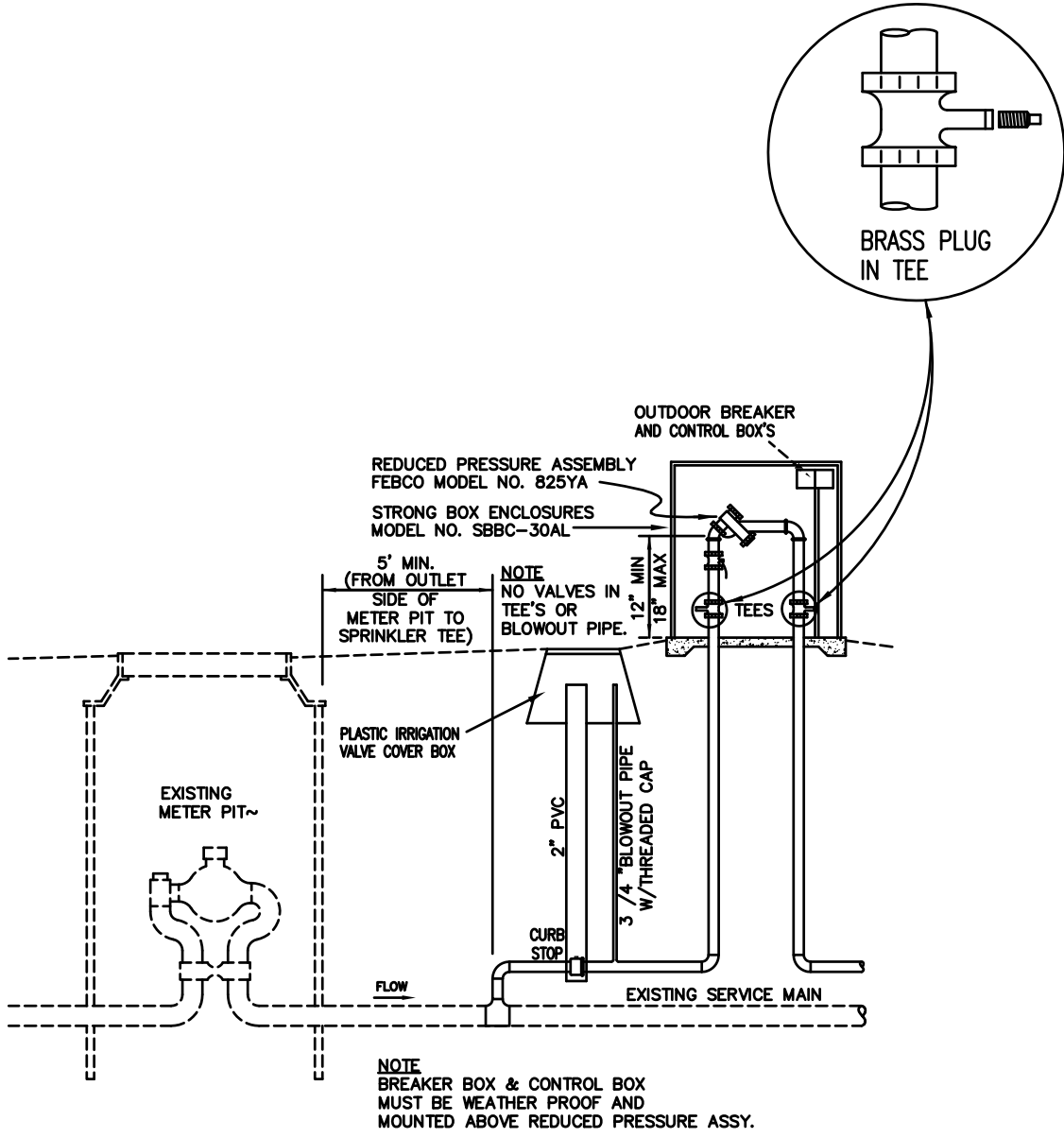

SPRINKLER TAP OFF DOMESTIC SERVICE WITH REDUCED PRESSURE ASSEMBLY

STANDARD SPRINKLER TAP DETAIL

DEPARTMENT OF PUBLIC WORKS AND PLANNING ENGINEERING DIVISION CITY OF GRAND JUNCTION, COLORADO	STANDARD WATERLINE DETAIL	APPROVED: <u>DN</u> DATE: <u>FEB. 2005</u> DRAWN: <u>TCP/DPW</u>	PAGE W-15
---	------------------------------	--	--------------

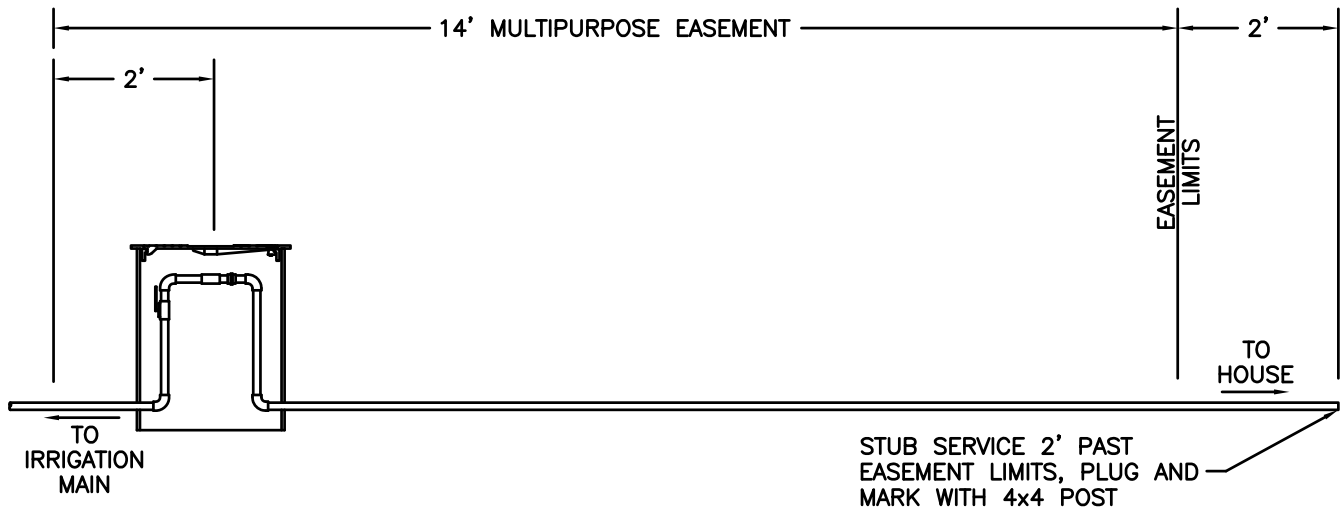
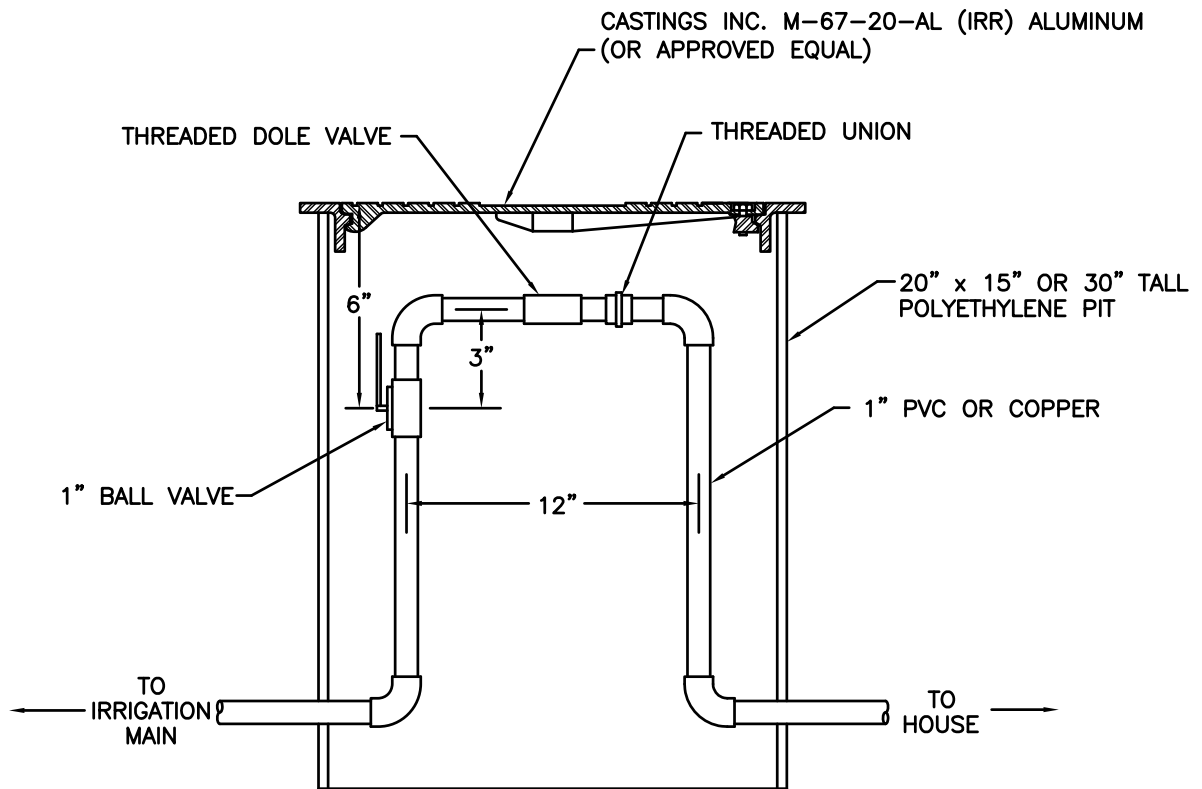

RIDGES IRRIGATION SERVICE DETAIL

DEPARTMENT OF PUBLIC WORKS AND PLANNING
ENGINEERING DIVISION
CITY OF GRAND JUNCTION, COLORADO

STANDARD WATERLINE
DETAIL

APPROVED: TCP
REV: FEB 2005
DRAWN: TCP/DPW

PAGE
W-16

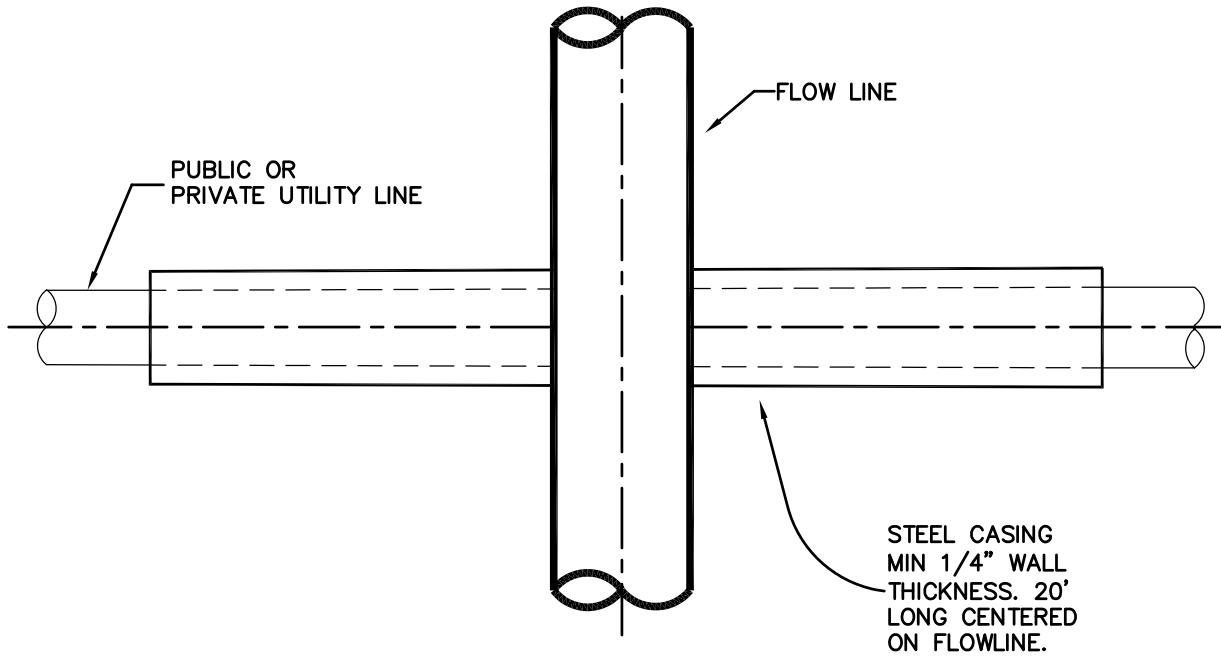

PLAN

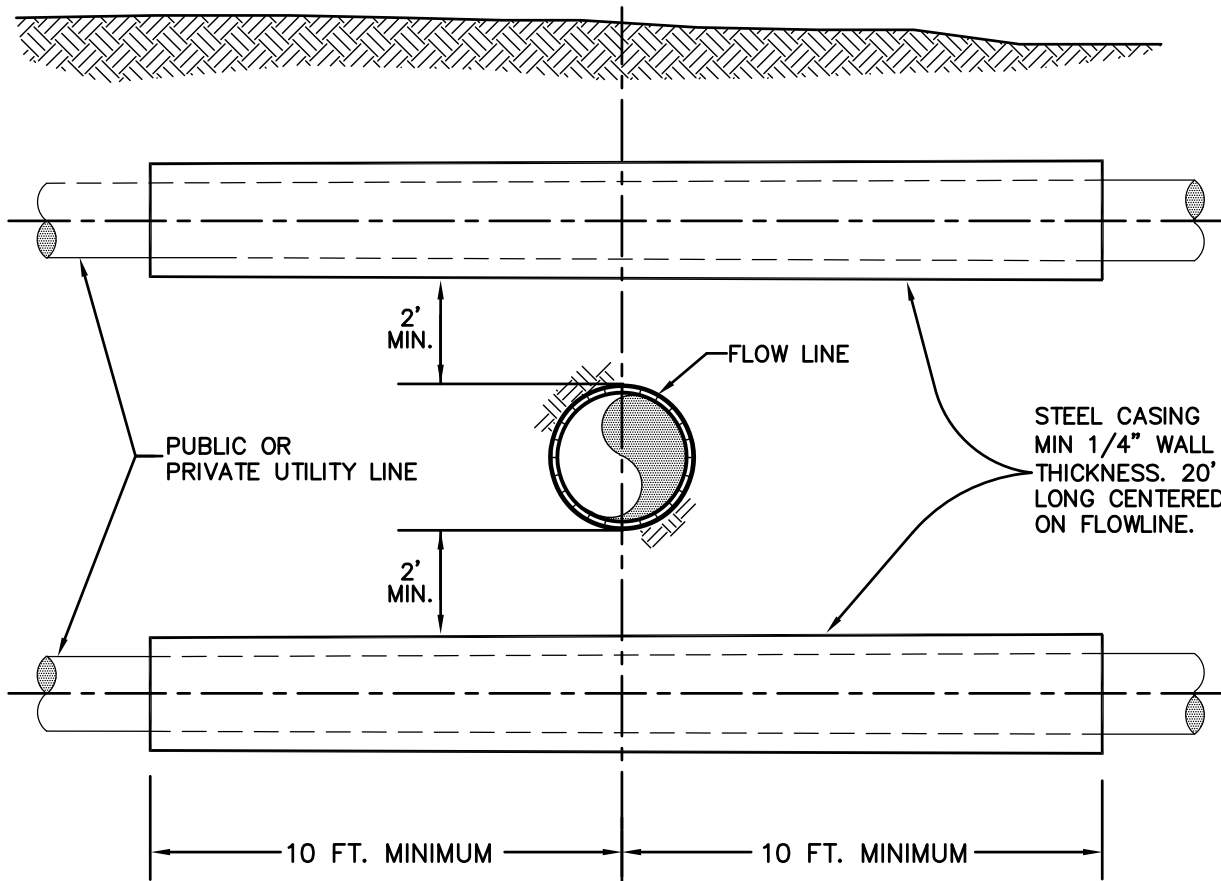

SECTION

TYPICAL DOMESTIC WATER FLOWLINE AND PUBLIC OR PRIVATE UTILITY CROSSING

DEPARTMENT OF PUBLIC WORKS AND PLANNING
ENGINEERING DIVISION
CITY OF GRAND JUNCTION, COLORADO

STANDARD WATERLINE
DETAIL

APPROVED: *SBG*
REV: *JUNE 2006*
DRAWN: *JCS*

PAGE
W-17

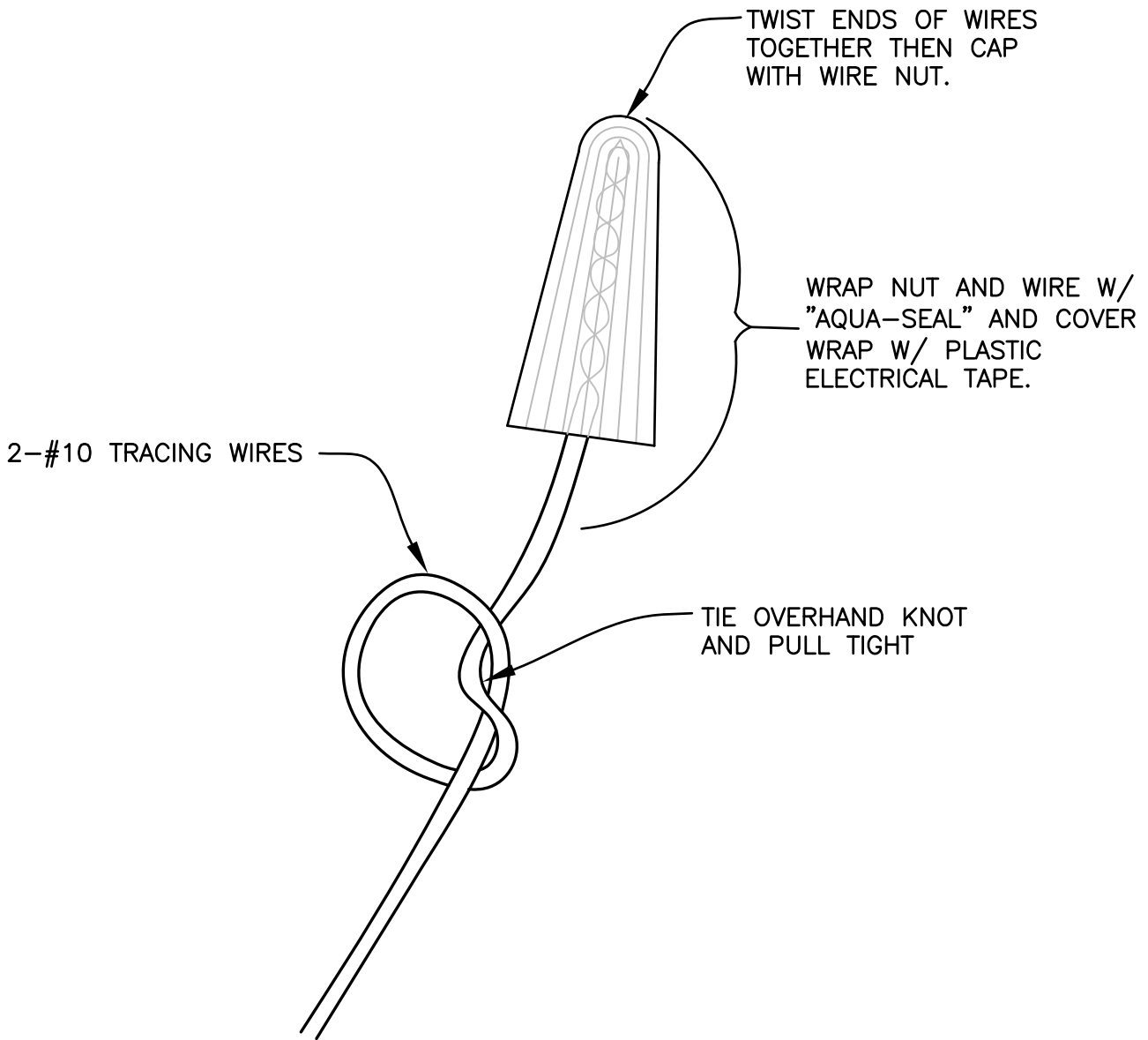

TRACING WIRE SPLICE DETAIL

DEPARTMENT OF PUBLIC WORKS AND PLANNING ENGINEERING DIVISION CITY OF GRAND JUNCTION, COLORADO	STANDARD WATERLINE DETAIL	APPROVED: <u>DN</u> REVISED: <u>JAN. 2009</u> DRAWN: <u>JAH</u>	PAGE W-18
---	------------------------------	---	--------------