



NOTICE TO PROCEED

Date: April 12, 2023
 Contractor: Mid-America Pool Renovation, Inc.
 Project: Lincoln Park-Moyer Pool Re-Plaster & Repair IFB-5177-23-KH

In accordance with the contract dated March 27, 2023 the Contractor is hereby notified to begin work on the Project on the week of April 17th.

The date of final completion as determined is May 15, 2023.

CITY OF GRAND JUNCTION, COLORADO

Kassy Hackett, Buyer

Receipt of this Notice to Proceed is hereby acknowledged:

Contractor: Mid-America Pool Renovation, Inc

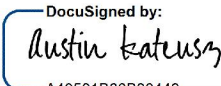
By: 
A40684D680B38440...

Print Name: Austin Kateusz

Title: President

Date: 4/13/2023



CITY OF GRAND JUNCTION, COLORADO

CONTRACT

This CONTRACT made and entered into this 27th day of March, 2023 by and between the City of Grand Junction, Colorado, a government entity in the County of Mesa, State of Colorado, hereinafter in the Contract Documents referred to as the "Owner" and Mid-America Pool Renovation, Inc. hereinafter in the Contract Documents referred to as the "Contractor."

WITNESSETH:

WHEREAS, the Owner advertised that sealed Bids would be received for furnishing all labor, tools, supplies, equipment, materials, and everything necessary and required for the Project described by the Contract Documents and known as Lincoln Park-Moyer Pool Re-Plaster & Repair IFB-5177-23-KH.

WHEREAS, the Contract has been awarded to the above-named Contractor by the Owner, and said Contractor is now ready, willing and able to perform the Work specified in the Notice of Award, in accordance with the Contract Documents;

NOW, THEREFORE, in consideration of the compensation to be paid the Contractor, the mutual covenants hereinafter set forth and subject to the terms hereinafter stated, it is mutually covenanted and agreed as follows:

ARTICLE 1

Contract Documents: It is agreed by the parties hereto that the following list of instruments, drawings, and documents which are attached hereto, bound herewith, or incorporated herein by reference constitute and shall be referred to either as the "Contract Documents" or the "Contract", and all of said instruments, drawings, and documents taken together as a whole constitute the Contract between the parties hereto, and they are fully a part of this agreement as if they were set out verbatim and in full herein:

The order of contract document governance shall be as follows:

- a. The body of this contract agreement
- b. Negotiated Terms and Conditions/Scope of Work etc.
- c. Solicitation Documents for the Project; Lincoln Park-Moyer Pool Re-Plaster & Repair;
- d. Notice of Award

- e. Contractors Response to the Solicitation
- f. Work Change Requests (directing that changed work be performed);
- g. Field Orders
- h. Change Orders.

ARTICLE 2

Definitions: The clauses provided in the Solicitation apply to the terms used in the Contract and all the Contract Documents.

ARTICLE 3

Contract Work: The Contractor agrees to furnish all labor, tools, supplies, equipment, materials, and all that is necessary and required to complete the tasks associated with the Work described, set forth, shown, and included in the Contract Documents as indicated in the Solicitation Document.

ARTICLE 4

Contract Time and Liquidated Damages: Time is of the essence with respect to this Contract. The Contractor hereby agrees to commence Work under the Contract on or before the date specified in the Solicitation from the Owner, and to achieve Substantial Completion and Final Completion of the Work within the time or times specified in the Solicitation. In the event the Work is not completed in the times set forth and as agreed upon, the Contractor further agrees to pay Liquidated Damages to the Owner as set forth in the Solicitation. The Contractor acknowledges and recognizes the delays, expenses and difficulties involved in proving in a legal proceeding the actual losses suffered by the Owner if the work is not completed on time. Accordingly, instead of requiring any such proof, the Owner and the Contractor agree that as Liquidated Damages for delay, but not as a penalty, the Contractor shall pay to the Owner the amounts specified in the Solicitation.

ARTICLE 5

Contract Price and Payment Procedures: The Contractor shall accept as full and complete compensation for the performance and completion of all of the Work specified in the Contract Documents, the sum of **Four Hundred Eight Thousand and 00/100 Dollars (\$408,000.00)**. If this Contract contains unit price pay items, the Contract Price shall be adjusted in accordance with the actual quantities of items completed and accepted by the Owner at the unit prices quoted in the Solicitation Response. The amount of the Contract Price is and has heretofore been appropriated by the Grand Junction City Council Board of Commissioners for the use and benefit of this Project. The Contract Price shall not be modified except by Change Order or other written directive of the Owner. The Owner shall not issue a Change Order or other written directive which requires additional work to be performed, which work causes the aggregate amount payable under this Contract to exceed the amount appropriated for this Project, unless and until the Owner provides Contractor written assurance that lawful appropriations to cover the costs of the additional work have been made.

Unless otherwise provided in the Solicitation, monthly partial payments shall be made as the Work progresses. Applications for partial and Final Payment shall be prepared by the Contractor and approved by the Owner in accordance with the Solicitation.

Upon Final Completion of the Work under the Contract and before the Contractor shall receive final payment, the Owner shall publish at least twice in a newspaper of general circulation published in the County a notice that: 1. the Owner has accepted such Work as completed according to the Contract Documents; 2. the Contractor is entitled to final payment therefore; 3. thirty days after the first publication, specifying the exact date, the Owner shall pay the full balance due under the Contract; and 4. persons having claims for labor, materials, team hire, sustenance, provisions, provender, or other supplies used or consumed by the Contractor or a subcontractor shall file a verified statement of the amount due and unpaid on account of such claim prior to the date specified for such payment. Nothing herein shall be construed as relieving the Contractor and the Sureties on the Contractor's Bonds from any claim or claims for work or labor done or materials or supplies furnished in the execution of the Contract.

ARTICLE 6

Bonds: The Contractor shall furnish currently herewith the Bonds required by the Contract Documents, such Bonds being attached hereto. The Performance Bond shall be in an amount not less than one hundred percent (100%) of the Contract Price set forth in Article 5. The Payment Bond shall be in an amount not less than one hundred (100%) of the Contract Price set forth in Article 5.

ARTICLE 7

Contract Binding: The Owner and the Contractor each binds itself, its partners, successors, assigns and legal representatives to the other party hereto in respect to all covenants, agreements and obligations contained in the Contract Documents. The Contract Documents constitute the entire agreement between the Owner and Contractor and may only be altered, amended or repealed by a duly executed written instrument. Neither the Owner nor the Contractor shall, without the prior written consent of the other, assign or sublet in whole or in part its interest under any of the Contract Documents and specifically, the Contractor shall not assign any moneys due or to become due without the prior written consent of the Owner.

ARTICLE 8

Severability: If any part, portion or provision of the Contract shall be found or declared null, void or unenforceable for any reason whatsoever by any court of competent jurisdiction or any governmental agency having the authority thereover, only such part, portion or provision shall be effected thereby and all other parts, portions and provisions of the Contract shall remain in full force and effect.

IN WITNESS WHEREOF, City of Grand Junction, Colorado, has caused this Contract to be subscribed and sealed and attested in its behalf; and the Contractor has signed this Contract the day and the year first mentioned herein.

The Contract is executed in two counterparts.

City of Grand Junction, CO

DocuSigned by:
Duane Hoff Jr.
By: _____
Duane Hoff Jr., Contract Administrator

3/29/2023

Date

Mid-America Pool Renovation, Inc.

DocuSigned by:
Austin Kateusz
By: _____
Austin Kateusz
President

3/27/2023

Date



NOTICE OF AWARD

Date: March 27, 2023
Company: Mid-America Pool Renovation, Inc.
Project: Lincoln Park-Moyer Pool Re-Plaster & Repair IFB-5177-23-KH

You have been awarded the City of Grand Junction Lincoln Park-Moyer Pool Re-Plaster & Repair IFB-5177-23-KH for the sum of **Four Hundred Eight Thousand and 00/100 Dollars (\$408,000.00).**

Please notify Larry Manchester, City of Grand Junction Recreation Supervisor 970-254-3844 for schedule and return to the City Purchasing Division an acknowledged copy of this Notice of Award, and Certificate of Insurance.

CITY OF GRAND JUNCTION, COLORADO

DocuSigned by:
Duane Hoff Jr.
9E789E7D50E14BC

Duane Hoff Jr., Contract Administrator

SUPPLIER ACKNOWLEDGEMENT

Receipt of this Notice to Award is hereby acknowledged:

Company: Mid-America Pool Renovation, Inc

By: *Austin Katusky*
A40581B60B38449...

Title: President

Date: 3/27/2023



Purchasing Division

Invitation for Bid

**IFB-5177-23-KH
Lincoln Park-Moyer Pool Re-Plaster & Repair**

Responses Due:

February 8, 2023 prior to 2:00 PM

Accepting Electronic Responses Only

Responses Only Submitted Through the Rocky Mountain E-Purchasing System (RMEPS)

<https://www.rockymountainbidsystem.com/default.asp>

(Purchasing Representative does not have access or control of the vendor side of RMEPS. If website or other problems arise during response submission, vendor MUST contact RMEPS to resolve issue prior to the response deadline. 800-835-4603)

NOTE: All City solicitation openings will continue to be held virtually.

Purchasing Representative:

Kassy Hackett, Buyer

kassyh@gjcity.org

970-244-1546

Invitation for Bids

Table of Contents

Section 1	Instruction to Bidders
Section 2	General Contract Conditions
Section 3	Statement of Work
Section 4	Contractor's Bid Form
	Price Proposal/Bid Schedule Form
	Attachments

1. Instructions to Bidders

NOTE: It is the Contractor's responsibility to read and review all solicitation documentation in its entirety, and to ensure that they have a clear and complete understanding of not only the scope, specifications, project requirements, etc., but also all other requirements, instructions, rules, regulations, laws, conditions, statements, procurement policies, etc. that are associated with the solicitation process and project/Work being solicited.

- 1.1. Purpose:** The City of Grand Junction is soliciting competitive bids from qualified and interested companies for all labor, equipment, and materials required to re-plaster and leak repair of the Lincoln Park-Moyer Swimming Pool. All dimensions and scope of work should be verified by Contractors prior to submission of bids. All contact regarding this IFB is to be directed to the Purchasing Agent:

Kassy Hackett, Buyer
kassyh@gjcity.org

With the exception of Pre-Bid or Site Visit Meeting(s) all questions, inquiries, comments, or communication pertaining to this solicitation (whether process, specifications, scope, etc.) must be directed in writing to the Purchasing Agent. Other communication may result in disqualification.

- 1.2. Optional Pre-Bid Meeting:** Prospective bidders are encouraged to attend an optional pre-bid meeting on January 24th at 1:30 PM. Meeting location shall be at the Lincoln Park – Moyer Pool, located at 1340 Gunnison Ave, Grand Junction, CO 81501. The purpose of this visit will be to inspect and to clarify the contents of this Invitation for Bids (IFB).
- 1.3. The Owner:** The Owner is the City of Grand Junction, Colorado and is referred to throughout this Solicitation. The term Owner means the Owner or its authorized representative.
- 1.4. Procurement Process:** The most current version of the City of Grand Junction [Purchasing Policy and Procedure Manual](#) is contracting.
- 1.5. Submission:** Bids be formatted as directed in Section 3.5. Submittals that fail to follow this format may be ruled non-responsive. Submittals that fail to follow this format may be ruled non-responsive.

Solicitation Opening, Lincoln Park-Moyer Pool Re-Plaster & Repair IFB-5177-23-KH
Feb 8, 2023, 2:00 – 2:30 PM (America/Denver)

Please join my meeting from your computer, tablet or smartphone.
<https://meet.goto.com/612260461>

You can also dial in using your phone.
Access Code: 612-260-461

United States: +1 (872) 240-3311
- One-touch: tel:+18722403311,,612260461#

Join from a video-conferencing room or system.
Meeting ID: 612-260-461
Dial in or type: 67.217.95.2 or inroomlink.goto.com
Or dial directly: 612260461@67.217.95.2 or 67.217.95.2##612260461

Get the app now and be ready when your first meeting starts:
<https://meet.goto.com/install>

- 1.6. Modification and Withdrawal of Bids Before Opening.** Bids may be modified or withdrawn by an appropriate document stating such, duly executed and submitted to the place where Bids are to be submitted at any time prior to Bid Opening.
- 1.7. Printed Form for Price Bid:** All Price Bids must be made upon the Price Bid Schedule attached and should give the amounts both in words and in figures, and must be signed and acknowledged by the bidder.

The Offeror shall specify a unit price in figures for each pay item for which a quantity is given and shall provide the products (in numbers) of the respective unit prices and quantities in the Extended Amount column. The total Bid price shall be equal to the sum of all extended amount prices. When an item in the Price Bid Schedule provides a choice to be made by the Offeror, Offeror's choice shall be indicated in accordance with the specifications for that particular item and thereafter no further choice shall be permitted.

Where the unit of a pay item is lump sum, the lump sum amount shall be shown in the "extended amount" column and included in the summation of the total Bid.

All blank spaces in the Price Bid Schedule must be properly filled out.

Bids by corporations must be executed in the corporate name by the president or vice president or other corporate office accompanied by evidence of authority to sign. The corporate address and state of incorporation shall be shown below the signature.

Bids by partnerships must be executed in the partnership name and signed by a partner whose title must appear under the signature and the official address of the partnership must be shown below the signature.

All names must be typed or printed below the signature.

The Offeror's Bid shall contain an acknowledgement of receipt of all Addenda, the numbers of which shall be filled in on the Contractor's Bid Form.

The contact information to which communications regarding the Bid are to be directed must be shown.

- 1.8. Exclusions:** No oral, telephonic, emailed, or facsimile bid will be considered

- 1.9. Contract Documents:** The complete IFB and bidder's response compose the Contract Documents. Copies of bid documents can be obtained from the City Purchasing website, <https://co-grandjunction.civicplus.com/501/Purchasing-Bids> .
- 1.10. Additional Documents:** The July 2010 edition of the "City Standard Contract Documents for Capital Improvements Construction", Plans, Specifications and other Bid Documents are available for review or download on the Purchasing Bids page at <https://co-grandjunction.civicplus.com/501/Purchasing-Bids>.
- 1.11. Definitions and Terms:** See Article I, Section 3 of the General Contract Conditions in the *Standard Contract Documents for Capital Improvements Construction* .
- 1.12. Examination of Specifications:** Bidders shall thoroughly examine and be familiar with the project Statement of Work. The failure or omission of any Offeror to receive or examine any form, addendum, or other document shall in no way relieve any Offeror from any obligation with respect to its bid. The submission of a bid shall be taken as evidence of compliance with this section. Prior to submitting a bid, each Offeror shall, at a minimum:
- a. Examine the *Contract Documents* thoroughly;
 - b. Visit the site to familiarize themselves with local conditions that may in any manner affect cost, progress, or performance of the Work;
 - c. Become familiar with federal, state, and local laws, ordinances, rules, and regulations that may in any manner affect cost, progress or performance of the Work;
 - d. Study and carefully correlate Bidder's observations with the *Contract Documents*, and;
 - e. Notify the Purchasing Agent of all conflicts, errors, ambiguities or discrepancies in or among the *Contract Documents* within the designated inquiry period.

On request, the Owner will provide each Offeror access to the site to conduct such investigations and tests as each Bidder deems necessary for submission of a Bid. It shall be the Offeror's responsibility to make or obtain any additional examinations, investigations, explorations, tests and studies and obtain any additional information and data which pertain to the physical conditions (including without limitation, surface, subsurface and underground utilities) at or contiguous to the site or otherwise which may affect cost, progress or performance of the Work and which the Offeror deems necessary to determine its Bid for performing the Work in accordance with the time, price and other terms and conditions of the Contract Documents. Location of any excavation or boring made by Offeror shall be subject to prior approval of Owner and applicable agencies. Offeror shall fill all holes, restore all pavements to match the existing structural section and shall clean up and restore the site to its former condition upon completion of such exploration. The Owner reserves the right to require the Offeror to execute an access agreement with the Owner prior to accessing the site.

The lands upon which the Work is to be performed, rights of way, and access thereto, and other lands designated for use by Contractor in performing the Work, are identified on the Drawings.

Information and data reflected in the *Contract Documents* with respect to underground utilities at or contiguous to the site are based upon information and data furnished to the Owner and the Engineer by the owners of such underground utilities or others, and the Owner does not assume responsibility for the accuracy or completeness thereof, unless it is expressly provided otherwise in the *Contract Documents*.

By submission of a Bid, the Offeror shall be conclusively presumed to represent that the Offeror has complied with every requirement of these Instructions to Bidders, that the *Contract Documents* are not ambiguous and are sufficient in scope and detail to indicate and convey understanding of all terms and conditions for performance of the Work.

- 1.13. **Questions Regarding Statement of Work:** Any information relative to interpretation of Scope of Work or specifications shall be requested of the Purchasing Representative, in writing, in ample time, prior to the inquiry deadline.
- 1.14. **Addenda & Interpretations:** If it becomes necessary to revise any part of this solicitation, a written addendum will be posted electronically on the City's website at <http://www.gjcity.org/business-and-economic-development/bids/>. The Owner is not bound by any oral representations, clarifications, or changes made in the written specifications by Owner, unless such clarification or change is provided in written addendum form from the City Purchasing Representative.
- 1.15. **Taxes:** The Owner is exempt from State retail and Federal tax. The bid price must be net, exclusive of taxes.
- 1.16. **Sales and Use Taxes:** The Contractor and all Subcontractors are required to obtain exemption certificates from the Colorado Department of Revenue for sales and use taxes in accordance with the provisions of the General Contract Conditions. Bids shall reflect this method of accounting for sales and use taxes on materials, fixtures and equipment.
- 1.17. **Offers Binding 60 Days:** Unless additional time is required by the Owner, or otherwise specified, all formal offers submitted shall be binding for sixty (60) calendar days following opening date, unless the Bidder, upon request of the Purchasing Representative, agrees to an extension.
- 1.18. **Exceptions and Substitutions:** All bids meeting the intent of this IFB shall be considered for award. A Contractor taking exception to the specifications does so at the Offeror's risk. The Owner reserves the right to accept or reject any or all substitutions or alternatives. When offering substitutions and/or alternatives, Contractor must state any exception(s) in the section to which the exception(s) pertains. Exception/substitution, if accepted, must meet or exceed the stated intent and/or specifications. The absence of stated exception(s) indicates that the Contractor has not taken exceptions, and if

awarded a Contract, shall hold the Contractor responsible to perform in strict accordance with the specifications or scope of the proposal and contract documents.

- 1.19. Collusion Clause:** Each Contractor by submitting a proposal certifies that it is not party to any collusive action or any action that may be in violation of the Sherman Antitrust Act. Any and all proposals shall be rejected if there is evidence or reason for believing that collusion exists among the proposers. The Owner may or may not, at its discretion, accept future proposals for the same service or commodities for participants in such collusion.
- 1.20. Disqualification of Bidders:** A Bid will not be accepted from, nor shall a Contract be awarded to, any person, Contractor, or corporation that is in arrears to the Owner, upon debt or contract, or that has defaulted, as surety or otherwise, upon any obligation to the Owner, or that is deemed irresponsible or unreliable.

Bidders may be required to submit satisfactory evidence that they are responsible, have a practical knowledge of the project bid upon and that they have the necessary financial and other resources to complete the proposed Work.

Either of the following reasons, without limitation, shall be considered sufficient to disqualify a Bidder and Bid:

- a. More than one Bid is submitted for the same Work from an individual, Contractor, or corporation under the same or different name; and
 - b. Evidence of collusion among Bidders. Any participant in such collusion shall not receive recognition as a Bidder for any future Work of the Owner until such participant has been reinstated as a qualified bidder.
- 1.21. Public Disclosure Record:** If the Bidder has knowledge of its employee(s) or sub-Contractors having an immediate family relationship with an Owner employee or elected official, the Bidder must provide the Purchasing Agent with the name(s) of the individuals. The individuals are required to file a "Public Disclosure Record", a statement of financial interest, before conducting business with the Owner.

2. General Contract Conditions for Construction Projects

- 2.1. The Contract:** This Invitation for Bid, submitted documents, and any negotiations, when properly accepted by the City, shall constitute a contract equally binding between the City and Contractor. The contract represents the entire and integrated agreement between the parties hereto and supersedes all prior negotiations, representations, or agreements, either written or oral. The contract may be amended or modified with Change Orders, Field Orders, or Addendums.
- 2.2. The Work:** The term Work includes all labor necessary to produce the construction required by the Contract Documents, and all materials and equipment incorporated or to be incorporated in such construction.

- 2.3. Execution, Correlation, Intent, and Interpretations:** The Contract Documents shall be signed by the Owner and Contractor. By executing the Contract, the Contractor represents that it has familiarized itself with the local conditions under which the Work is to be performed and correlated its observations with the requirements of the Contract Documents. The Contract Documents are complementary, and what is required by anyone, shall be as binding as if required by all. The intention of the Contract Documents is to include all labor, materials, equipment, Work and other items necessary for the proper execution and completion of the Scope of Work as defined in the technical specifications and/or drawings contained herein. All drawings, specifications and copies furnished by the Owner are, and shall remain, Owner property. They are not to be used on any other project.
- 2.4. The Owner:** The Owner is the City of Grand Junction, Colorado and is referred to throughout the Contract Documents. The term Owner means the Owner or its authorized representative. The Owner shall, at all times, have access to the Work wherever it is in preparation and progress. The Contractor shall provide facilities for such access. The Owner will make periodic visits to the site to familiarize itself generally with the progress and quality of Work and to determine, in general, if the Work is proceeding in accordance with the contract documents. Based on such observations and the Contractor's Application for Payment, the Owner will determine the amounts owing to the Contractor and will issue Certificates for Payment in such amounts, as provided in the contract. The Owner will have authority to reject Work which does not conform to the Contract documents. Whenever, in its reasonable opinion, it considers it necessary or advisable to insure the proper implementation of the intent of the Contract Documents, it will have authority to require the Contractor to stop the Work or any portion, or to require special inspection or testing of the Work, whether or not such Work can be then be fabricated, installed, or completed. The Owner will not be responsible for the acts or omissions of the Contractor, and sub-Contractor, or any of its agents or employees, or any other persons performing any of the Work.
- 2.5. Contractor:** The Contractor is the person or organization identified as such in the Agreement and is referred to throughout the Contract Documents. The term Contractor means the Contractor or its authorized representative. The Contractor shall carefully study and compare the General Contract Conditions of the Contract, Specification and Drawings, Scope of Work, Addenda and Modifications and shall at once report to the Owner any error, inconsistency or omission it may discover. Contractor shall not be liable to the Owner for any damage resulting from such errors, inconsistencies or omissions. The Contractor shall not commence Work without clarifying Drawings, Specifications, or Interpretations.
- 2.6. Sub-Contractors:** A sub-contractor is a person or organization who has a direct contract with the Contractor to perform any of the Work at the site. The term sub-Contractor is referred to throughout the contract documents and means a sub-Contractor or its authorized representative.
- 2.7. Award of Sub-Contractors & Other Contracts for Portions of the Work:** Contractor shall submit with its bid response to the Owner, in writing for acceptance, a list of the names of the sub-Contractors or other persons or organizations proposed for such portions of the Work as may be designated in the proposal requirements, or, if none is

so designated, the names of the sub-Contractors proposed for the principal portions of the Work. Prior to the award of the contract, the Owner shall notify the successful Contractor in writing if, after due investigation, has reasonable objection to any person or organization on such list. If, prior to the award of the contract, the Owner has a reasonable and substantial objection to any person or organization on such list, and refuses in writing to accept such person or organization, the successful Contractor may, prior to the award, withdraw its proposal without forfeiture of proposal security. If the successful Contractor submits an acceptable substitute with an increase in the proposed price to cover the difference in cost occasioned by the substitution, the Owner may, at its discretion, accept the increased proposal or may disqualify the Contractor. If, after the award, the Owner refuses to accept any person or organization on such list, the Contractor shall submit an acceptable substitute and the contract sum shall be increased or decreased by the difference in cost occasioned by such substitution and an appropriate Change Order shall be issued. However, no increase in the contract sum shall be allowed for any such substitution unless the Contractor has acted promptly and responsively in submitting a name with respect thereto prior to the award.

- 2.8. Substitutions:** The materials, products and equipment described in the *Solicitation Documents* shall be regarded as establishing a standard of required performance, function, dimension, appearance, or quality to be met by any proposed substitution. No substitution will be considered prior to receipt of Bids unless the Offeror submits a written request for approval to the City Purchasing Division at least ten (10) days prior to the date for receipt of Bids. Such requests for approval shall include the name of the material or equipment for which substitution is sought and a complete description of the proposed substitution including drawings, performance and test data, and other information necessary for evaluation, including samples if requested. The Offeror shall set forth changes in other materials, equipment, or other portions of the Work including changes of the Work of other contracts, which incorporation of the proposed substitution would require to be included. The Owner's decision of approval or disapproval of a proposed substitution shall be final. If the Owner approves a proposed substitution before receipt of Bids, such approval will be set forth in an Addendum. Offerors shall not rely upon approvals made in any other manner.
- 2.9. Supervision and Construction Procedures:** The Contractor shall supervise and direct the Work, using its best skill and attention. It shall be solely responsible for all construction means, methods, techniques, sequences and procedures and for coordinating all portions of the Work under the contract.
- 2.10. Warranty:** The Contractor warrants to the Owner that all materials and equipment furnished under this contract will be new unless otherwise specified, and that all Work will be of good quality, free from faults and defects and in conformance with the Contract Documents. All Work not so conforming to these standards may be considered defective. If required by Owner, the Contractor shall furnish satisfactory evidence as to the kind and quality of materials and equipment. If within ten (10) days after written notice to the Contractor requesting such repairs or replacement, the Contractor should neglect to make or undertake with due diligence to the same, the City may make such repairs or replacements. All indirect and direct costs of such correction or removal or replacement shall be at the Contractor's expense. The Contractor will also bear the

expenses of making good all Work of others destroyed or damaged by the correction, removal or replacement of its defective Work.

- 2.11. Permits, Fees, & Notices:** The Contractor shall secure and pay for all permits, governmental fees and licenses necessary for the proper execution and completion of the Work. The Contractor shall give all notices and comply with all laws, ordinances, rules, regulations and orders of any public authority, including the City, bearing on the performance of the Work. If the Contractor observes that any of the Contract Documents are at variance in any respect, it shall promptly notify the Purchasing Agent in writing, and any necessary changes shall be adjusted. If the Contractor performs any Work knowing it to be contrary to such laws, ordinances, rules and regulations, and without such notice to the Owner, it shall assume full responsibility and shall bear all costs attributable to the non-conforming Work.
- 2.12. Responsibility for Those Performing the Work:** The Contractor shall be responsible to the Owner for the acts and omissions of all its employees and all sub-Contractors, its agents and employees, and all other persons performing any of the Work under a contract with the Contractor.
- 2.13. Use of the Site:** The Contractor shall confine operations at the site to areas permitted by law, ordinances, permits and the Contract Documents, and shall not unreasonably encumber the site with any materials or equipment.
- 2.14. Cleanup:** The Contractor at all times shall keep the premises free from accumulation of waste materials or rubbish caused by its operations. At the completion of Work shall remove all its waste materials and rubbish from and about the project, as well as all its tools, construction equipment, machinery and surplus materials.
- 2.15. Insurance:** The Contractor shall file a copy of the policies or Certificates of Insurance acceptable to the City with the Engineer within ten (10) Calendar Days after issuance of the Notice of Award. These Certificates of Insurance shall contain a provision that coverage afforded under the policies shall not be canceled unless at least thirty (30) Calendar Days prior written notice has been given to the City.
- 2.16. Indemnification:** The Contractor shall defend, indemnify and save harmless the Owner, and all its officers, employees, insurers, and self-insurance pool, from and against all liability, suits, actions, or other claims of any character, name and description brought for or on account of any injuries or damages received or sustained by any person, persons, or property on account of any negligent act or fault of the Contractor, or of any Contractor's agent, employee, sub-Contractor or supplier in the execution of, or performance under, any contract which may result from proposal award. Contractor shall pay any judgment with costs which may be obtained by and/or against the Owner arising out of or under the performance.
- 2.17. Miscellaneous Conditions: Material Availability:** Contractors must accept responsibility for verification of material availability, production schedules, and other pertinent data prior to submission of bid. It is the responsibility of the bidder to notify the Owner immediately if materials specified are discontinued, replaced, or not available for an extended period of time. **OSHA Standards:** All bidders agree and warrant that Work

performed in response to this invitation shall conform to the standards declared by the US Department of Labor under the Occupational Safety and Health Act of 1970 (OSHA). In the event the Work do not conform to OSHA standards, the Owner may require the Work to be redone at no additional expense to the Owner.

- 2.18. Time:** Time is of the essence with respect to the time of completion of the Project and any other milestones or deadline which are part of the Contract. It will be necessary for each Bidder to satisfy the City of its ability to complete the Work within the Contract Time set forth in the Contract Documents. The Contract Time is the period of time allotted in the Contract Documents for completion of the Work. The date of commencement of the Work is the date established in a Notice to Proceed. If there is no Notice to Proceed, it shall be the date of the Contract or such other date as may be established therein, or as established as entered on the Bid Form. The Date of Final Completion of the Work is the date certified by the Owner when all construction, and all other Work associated to include, but not be limited to: testing, QA/QC, receipt of required reports and/or forms, grant requirements (if applicable), punch list items, clean-up, receipt of drawings and/or as-builts, etc., is fully complete, and in accordance with the Contract Documents.
- 2.19. Progress & Completion:** The Contractor shall begin Work on the date of commencement as defined in the Contract and shall carry the Work forward expeditiously with adequate forces and shall complete it within the contract time.
- 2.20. Payment & Completion:** The Contract Sum is stated in the Contract and is the total amount payable by the Owner to the Contractor for the performance of the Work under the Contract Documents. Upon receipt of written notice that the Work is ready for final inspection and acceptance and upon receipt of application for payment, the Owner's Project Manager will promptly make such inspection and, when it finds the Work acceptable under the Contract Documents and the Contract fully performed, the Owner shall make payment in the manner provided in the Contract Documents.
- 2.21. Bid Bond:** Each Bid shall as a guaranty of good faith on the part of the Bidder be accompanied by a Bid Guaranty consisting of: a certified or cashier's check drawn on an approved national bank or trust company in the state of Colorado, and made payable without condition to the City; or a **Bid Bond** written by an approved corporate surety in favor of the City. The amount of the Bid Guaranty shall not be less than 5% of the total Bid amount. Once a Bid is accepted and a Contract is awarded, the apparent successful bidder has ten calendar days to enter into a Contractor in the form prescribed and to furnish the bonds with a legally responsible and approved surety. Failure to do so will result I forfeiture of the Bid Guaranty to the City as Liquidated Damages.

Each bidder shall guaranty its total bid price for a period of sixty (60) Calendar Days from the date of the bid opening.

- 2.22. Performance & Payment Bonds:** Contractor shall furnish a Performance and a Payment Bond, each in an amount at least equal to that specified for the contract amount as security for the faithful performance and payment of all Contractor's obligations under the Contract Documents. These bonds shall remain in effect for the duration of the Warranty Period (as specified in the Special Conditions). Contractor shall also furnish other bonds that may be required by the Special Conditions. All bonds shall be in the

forms prescribed by the Contract Documents and be executed by such sureties as (1) are licensed to conduct business in the State of Colorado and (2) are named in the current list of "Companies Holding Certificates of Authority as Acceptable Sureties on Federal Bonds and as Acceptable Reinsuring Companies" as published in Circular 570 (amended) by the Audit Staff, Bureau of Accounts, U.S. Treasury Department. All bonds signed by an agent must be accompanied by a certified copy of the Authority Act. If the surety on any bond furnished by the Contractor is declared bankrupt, or becomes insolvent, or its rights to do business in Colorado are terminated, or it ceases to meet the requirements of clauses (1) and (2) of this section, Contractor shall within five (5) days thereafter substitute another bond and surety, both of which shall be acceptable to the City.

- 2.23. Retention:** The Owner will deduct money from the partial payments in amounts considered necessary to protect the interest of the Owner and will retain this money until after completion of the entire contract. The amount to be retained from partial payments will be five (5) percent of the value of the completed Work, and not greater than five (5) percent of the amount of the Contract. When the retainage has reached five (5) percent of the amount of the Contract no further retainage will be made and this amount will be retained until such time as final payment is made.
- 2.24. Liquidated Damages for Failure to Enter Into Contract:** Should the Successful Bidder fail or refuse to enter into the Contract within ten Calendar Days from the issuance of the Notice of Award, the City shall be entitled to collect the amount of such Bidder's Bid Guaranty as Liquidated Damages, not as a penalty but in consideration of the mutual release by the City and the Successful Bidder of all claims arising from the City's issuance of the Notice of Award and the Successful Bidder's failure to enter into the Contract and the costs to award the Contract to any other Bidder, to readvertise, or otherwise dispose of the Work as the City may determine best serves its interest.
- 2.25. Liquidated Damages for Failure to Meet Project Completion Schedule:** If the Contractor does not achieve Final Completion by the required date, whether by neglect, refusal or any other reason, the parties agree and stipulate that the Contractor shall pay liquidated damages to the City for each such day that final completion is late. As provided elsewhere, this provision does not apply for delays caused by the City. The date for Final Completion may be extended in writing by the Owner.

The Contractor agrees that as a part of the consideration for the City's awarding of this Contract liquidated damages in the daily amount of **\$350.00** is reasonable and necessary to pay for the actual damages resulting from such delay. The parties agree that the real costs and injury to the City for such delay include hard to quantify items such as: additional engineering, inspection and oversight by the City and its agents; additional contract administration; inability to apply the efforts of those employees to the other Work of the City; perceived inefficiency of the City; citizens having to deal with the construction and the Work, rather than having the benefit of a completed Work, on time; inconvenience to the public; loss of reputation and community standing for the City during times when such things are very important and very difficult to maintain.

The Contractor must complete the Work and achieve final completion included under the Bid Schedule in the number of consecutive calendar days after the City gives is written

Notice to Proceed. When the Contractor considers the entire Work ready for its intended use, Contractor shall certify in writing that the Work is fully complete. Final Completion date is the date by which the Contractor shall have fully completed all clean-up, and all items that were identified by the City in the inspection for final completion. Unless otherwise stated in the Special Conditions, for purposes of this liquidated damages clause, the Work shall not be finished and the Contract time shall continue to accrue until the City gives its written Final Acceptance.

If the Contractor shall fail to pay said liquidated damages promptly upon demand thereof after having failed to achieve Final Completion on time, the City shall first look to any retainage or other funds from which to pay said liquidated damages; if retainage or other liquid funds are not available to pay said liquidated damages amounts, the Surety on the Contractor's Performance Bond and Payment Bond shall pay such liquidated damages. In addition, the City may withhold all, or any part of, such liquidated damages from any payment otherwise due the Contractor.

Liquidated damages as provided do not include any sums to reimburse the City for extra costs which the City may become obligated to pay on other contracts which were delayed or extended because of the Contractor's failure to complete the Work within the Contract Time. Should the City incur additional costs because of delays or extensions to other contracts resulting from the Contractor's failure of timely performance, the Contractor agrees to pay these costs that the City incurs because of the Contractor's delay, and these payments are separate from and in addition to any liquidated damages.

The Contractor agrees that the City may use its own forces or hire other parties to obtain Final Completion of the Work if the time of completion has elapsed and the Contractor is not diligently pursuing completion. In addition to the Liquidated Damages provided for, the Contractor agrees to reimburse the City for all expenses thus incurred.

2.26. Contingency/Force Account/Minor Contract Revisions: Contingency/Force Account/Minor Contract Revisions Work will be authorized by the Owner's Project Manager and is defined as minor expenses to cover miscellaneous or unforeseen expenses related to the project. The expenses are not included in the Drawings, Specifications, or Scope of Work and are necessary to accomplish the scope of this contract. Contingency/Force Account/Minor Contract Revisions Authorization will be directed by the Owner through an approved form. Contingency/Force Account/Minor Contract Revisions funds are the property of the Owner and any Contingency/Force Account/Minor Contract Revisions funds, not required for project completion, shall remain the property of the Owner. Contractor is not entitled to any Contingency/Force Account/Minor Contract Revisions funds, that are not authorized by Owner or Owner's Project Manager.

2.27. Protection of Persons & Property: The Contractor shall comply with all applicable laws, ordinances, rules, regulations and orders of any public authority having jurisdiction for the safety of persons or property or to protect them from damage, injury or loss. Contractor shall erect and maintain, as required by existing safeguards for safety and protection, and all reasonable precautions, including posting danger signs or other warnings against hazards promulgating safety regulations and notifying owners and users of adjacent utilities. When or where any direct or indirect damage or injury is done to public or private property by or on account of any act, omission, neglect, or misconduct

by the Contractor in the execution of the Work, or in consequence of the non-execution thereof by the Contractor, it shall restore, at its own expense, such property to a condition similar or equal to that existing before such damage or injury was done, by repairing, rebuilding, or otherwise restoring as may be directed, or it shall make good such damage or injury in an acceptable manner.

- 2.28. Changes in the Work:** The Owner, without invalidating the contract, may order changes in the Work within the general scope of the contract consisting of additions, deletions or other revisions, the contract sum and the contract time being adjusted accordingly. All such changes in the Work shall be authorized by Change Order and shall be executed under the applicable conditions of the contract documents. A Change Order is a written order to the Contractor signed by the Owner issued after the execution of the contract, authorizing a change in the Work or an adjustment in the contract sum or the contract time. The contract sum and the contract time may be changed only by Change Order.
- 2.29. Claims for Additional Cost or Time:** If the Contractor wishes to make a claim for an increase in the contract sum or an extension in the contract time, it shall give the Owner written notice thereof within a reasonable time after the occurrence of the event giving rise to such claim. This notice shall be given by the Contractor before proceeding to execute the Work, except in an emergency endangering life or property in which case the Contractor shall precede in accordance with the regulations on safety. No such claim shall be valid unless so made. Any change in the contract sum or contract time resulting from such claim shall be authorized by Change Order.
- 2.30. Minor Changes in the Work:** The Owner shall have authority to order minor changes in the Work not involving an adjustment in the contract sum or an extension of the contract time and not inconsistent with the intent of the contract documents.
- 2.31. Field Orders:** The Owner may issue written Field Orders which interpret the Contract Documents in accordance with the specifications, or which order minor changes in the Work in accordance with the agreement, without change in the contract sum or time. The Contractor shall carry out such Field Orders promptly.
- 2.32. Uncovering & Correction of Work:** The Contractor shall promptly correct all Work rejected by the Owner as defective or as failing to conform to the contract documents whether observed before or after substantial completion and whether or not fabricated installed or competed. The Contractor shall bear all costs of correcting such rejected Work, including the cost of the Owner's additional Work thereby made necessary. If within one (1) year after the date of completion or within such longer period of time as may be prescribed by law or by the terms of any applicable special guarantee required by the contract documents, any of the Work found to be defective or not in accordance with the contract documents, the Contractor shall correct it promptly after receipt of a written notice from the Owner to do so unless the Owner has previously given the Contractor a written acceptance of such condition. The Owner shall give such notice promptly after discover of condition. All such defective or non-conforming Work under the above paragraphs shall be removed from the site where necessary and the Work shall be corrected to comply with the contract documents without cost to the Owner. The Contractor shall bear the cost of making good all Work of separate Contractors destroyed or damaged by such removal or correction. If the Owner prefers to accept defective or

non-conforming Work, it may do so instead of requiring its removal and correction, in which case a Change Order will be issued to reflect an appropriate reduction in the payment or contract sum, or, if the amount is determined after final payment, it shall be paid by the Contractor.

- 2.34. Amendment:** No oral statement of any person shall modify or otherwise change, or affect the terms, conditions or specifications stated in the Contract. All amendments to the Contract shall be made in writing by the City Contract Administrator.
- 2.35. Assignment:** The Contractor shall not sell, assign, transfer or convey the Contract resulting from this IFB, in whole or in part, without the prior written approval from the Owner.
- 2.36. Compliance with Laws:** Bids must comply with all Federal, State, County and local laws governing of the service and the fulfillment of the Work for and on behalf of the public. Contractor hereby warrants that it is qualified to assume the responsibilities and render the Work described herein and has all requisite corporate authority and professional licenses in good standing, required by law.
- 2.37. Confidentiality:** All information disclosed by the Owner to the Contractor for the purpose of the Work to be done or information that comes to the attention of the Contractor during the course of performing such Work is to be kept strictly confidential.
- 2.38. Conflict of Interest:** No public official and/or City/County employee shall have interest in the Contract resulting from this Invitation for Bid.
- 2.39. Contract Termination:** The Contract shall remain in effect until any of the following occurs: (1) Contract expires; (2) completion of Work; (3) acceptance of Work or, (4) for convenience terminated by either party with a written *Notice of Cancellation* stating therein the reasons for such cancellation and the effective date of cancellation at least thirty days past notification.
- 2.40. Employment Discrimination:** During the performance of any Work per agreement with the Owner, the Contractor agrees to:
 - 2.40.1.** Not discriminate against any employee or applicant for employment because of race, religion, color, sex, age, handicap, or national origin except when such condition is a legitimate occupational qualification reasonably necessary for the normal operations of the Contractor. The Contractor agrees to post in conspicuous places, visible to employees and applicants for employment, notices setting forth the provisions of this nondiscrimination clause.
 - 2.40.2.** In all solicitations or advertisements for employees placed by or on behalf of the Contractor, that the Contractor is an Equal Opportunity Employer.
 - 2.40.3.** Notices, advertisements, and solicitations placed in accordance with federal law, rule, or regulation shall be deemed sufficient for the purpose of meeting the requirements of this section.

- 2.41. Affirmative Action:** In executing a Contract with the City, the Contractor agrees to comply with Affirmative Action and Equal Employment Opportunity regulations presented in the General Contract Conditions.
- 2.42. Immigration Reform and Control Act of 1986 and Immigration Compliance:** The Contractor certifies that it does not and will not during the performance of the Contract employ Worker(s) without authorization Work or otherwise violate the provisions of the Federal Immigration Reform and Control Act of 1986 and/or law regulating immigration compliance.
- 2.43. Ethics:** The Contractor shall not accept or offer gifts or anything of value and/or enter into any business arrangement with any employee, official, or agent of the Owner.
- 2.44. Failure to Deliver:** In the event of failure of the Contractor to perform in accordance with the Contract Documents, the Owner, after due oral or written notice, may procure Work from other sources and hold the Contractor responsible for any and all costs resulting in the purchase of additional Work and materials necessary to perform the Work. This remedy shall be in addition to any other remedies that the Owner may have.
- 2.45. Failure to Enforce:** Failure by the Owner at any time to enforce the provisions of the Contract shall not be construed as a waiver of any such provisions. Such failure to enforce shall not affect the validity of the Contract or any part thereof or the right of the Owner to enforce any provision of the Contract Documents at any time in accordance with the terms thereof.
- 2.46. Force Majeure:** The Contractor shall not be held responsible for failure to perform the duties and responsibilities imposed by the Contract due to legal strikes, fires, riots, rebellions, and acts of God beyond the control of the Contractor, unless otherwise specified in the Contract.
- 2.47. Independent Contractor:** The Contractor shall be legally considered an independent Contractor and neither the Contractor nor its employees shall, under any circumstances, be considered servants or agents of the Owner. The Owner shall be at no time legally responsible for any negligence or other wrongdoing by the Contractor, its servants, or agents. The Owner shall not withhold from the Contract payments to the Contractor any federal or state unemployment taxes, federal or state income taxes, Social Security or any other amounts for benefits to the Contractor. Further, the Owner shall not provide to the Contractor any insurance coverage or other benefits, including Workers' Compensation, normally provided by the Owner for its employees.
- 2.48. Nonconforming Terms and Conditions:** A bid that includes terms and conditions that do not conform to the terms and conditions of this Invitation for Bid is subject to rejection as non-responsive. The Owner reserves the right to permit the Contractor to withdraw nonconforming terms and conditions from its bid prior to a determination by the Owner of non-responsiveness based on the submission of nonconforming terms and conditions.

Items for non-responsiveness may include, but not be limited to:

- a. Submission of the Bid on forms other than those supplied by the City;
- b. Alteration, interlineation, erasure, or partial detachment of any part of the forms which are supplied herein;
- c. Inclusion of unauthorized additions conditional or alternate Bids or irregularities of any kind which may tend to make the Bid incomplete, indefinite, or ambiguous as to its meaning;
- d. Failure to acknowledge receipt of any or all issued Addenda;
- e. Failure to provide a unit price or a lump sum price, as appropriate, for each pay item listed except in the case of authorized alternative pay items;
- f. Failure to list the names of Sub-Contractors used in the Bid preparation as may be required in the Solicitation Documents;
- g. Submission of a Bid that, in the opinion of the Owner, is unbalanced so that each item does not reasonably carry its own proportion of cost or which contains inadequate or unreasonable prices for any item;
- h. Tying of the Bid with any other bid or contract; and
- i. Failure to calculate Bid prices as described herein.

2.49. Evaluation of Bids and Offerors: The Owner reserves the right to:

- reject any and all Bids,
- waive any and all informalities,
- take into account any prompt payment discounts offered by Bidder,
- negotiate final terms with the Successful Bidder,
- take into consideration past performance of previous awards/contracts with the Owner of any Contractor, Vendor, Firm, Supplier, or Service Provider in determining final award. and
- disregard any and all nonconforming, nonresponsive or conditional Bids.

Discrepancies between words and figures will be resolved in favor of words. Discrepancies between Unit Prices and Extended Prices will be resolved in favor of the Unit Prices. Discrepancies between the indicated sum of any column of figures and the correct sum thereof will be resolved in favor of the correct sum. The corrected extensions and totals will be shown in the tabulation of Bids.

The Owner may consider the qualifications and experience of Sub-Contractors and other persons and organizations (including those who are to furnish the principal items of material or equipment) proposed for those portions of the Work as to which the identity of Sub-Contractors and other persons and organizations must be submitted. Operating costs, maintenance considerations performance data, and guarantees of materials and equipment may also be considered by the Owner.

The Owner will conduct such investigations as deemed necessary to assist in the evaluation of any Bid and to establish the responsibility, qualifications and financial ability of the Offeror, proposed Sub-Contractors and other persons and organizations to do the Work in accordance with the *Contract Documents* to the City's satisfaction within the Contract Time.

The Offeror shall furnish the Owner all information and data requested by the Owner to determine the ability of the Offeror to perform the Work. The Owner reserves the right to reject the Bid if the evidence submitted by, or investigation of such Offeror fails to satisfy the Owner that such Offeror is properly qualified to carry out the obligations of the Contract and to complete the Work contemplated therein.

By submitting a Bid, each Offeror authorizes the Owner to perform such investigation of the Offeror as the Owner deems necessary to establish the responsibility, qualifications and financial ability of the Offeror and, by its signature thereon, authorizes the Owner to obtain reference information concerning the Offeror and releases the party providing such information and the Owner from any and all liability to the Offeror as a result of such reference information so provided.

The Owner reserves the right to reject the Bid of any Offeror who does not pass any evaluation to the Owner's satisfaction.

If the Contract is to be awarded, it will be awarded to the Offeror who, by evaluation, the Owner determines will best meet the Owner's interests.

The Owner reserves the right to accept or reject the Work contained in any of the Price Bid Schedules or alternates, either in whole or in part.

2.50. Award of Contract: Unless otherwise indicated, a single award will be made for all the bid items in an individual bid schedule. In the event that the Work is contained in more than one Bid Schedule, the City may award Schedules individually or in combination. In the case of two Bid Schedules which are alternative to each other, only one of such alternative Schedules will be awarded. Within forty-five (45) Calendar Days of Bid Opening, the City will issue a Notice of Award to the Successful Bidder which will be accompanied by four (4) unsigned copies of the Contract and the Performance and Payment Bond forms. Within ten (10) Calendar Days thereafter, the Successful Bidder shall sign and deliver four (4) copies of the Contract, Performance Bond, Payment Bond and Certificates of Insurance to the City. Within ten (10) Calendar Days thereafter, the City will deliver two (2) fully executed counterparts of the Contract to the Contractor. No contract shall exist between the Successful Bidder and the City and the Successful Bidder shall have no rights at law or in equity until the Contract has been duly executed by the City.

The Successful Bidder's failure to sign and submit a Contract and other documents set forth in this Paragraph within the prescribed time shall be just cause of annulment of the award, and forfeiture of the Bid Guaranty. The award of Contract may then be made to the next qualified Bidder in the same manner as previously prescribed.

- 2.51. Ownership:** All plans, prints, designs, concepts, etc., shall become the property of the Owner.
- 2.52. Oral Statements:** No oral statement of any person shall modify or otherwise affect the terms, conditions, or specifications stated in this document and/or resulting agreement. All modifications to this request and any agreement must be made in writing by the Owner.
- 2.53. Patents/Copyrights:** The Contractor agrees to protect the Owner from any claims involving infringements of patents and/or copyrights. In no event shall the Owner be liable to the Contractor for any/all suits arising on the grounds of patent(s)/copyright(s) infringement. Patent/copyright infringement shall null and void any agreement resulting from response to this Invitation for Bid.
- 2.54. Remedies:** The Contractor and Owner agree that both parties have all rights, duties, and remedies available as stated in the Uniform Commercial Code.
- 2.55. Venue:** Any agreement as a result of responding to this IFB shall be deemed to have been made in, and shall be construed and interpreted in accordance with, the laws of the City of Grand Junction, Mesa County, Colorado.
- 2.56. Expenses:** Expenses incurred in preparation, submission and presentation of this IFB are the responsibility of the company and cannot be charged to the Owner.
- 2.57. Sovereign Immunity:** The Owner specifically reserves its right to sovereign immunity pursuant to Colorado State Law as a defense to any action arising in conjunction to this agreement.
- 2.58. Non-Appropriation of Funds:** The contractual obligation of the Owner under this contract is contingent upon the availability of appropriated funds from this fiscal year budget as approved by the City Council or Board of County Commissioners from this fiscal year only. State of Colorado law prohibit obligation of public funds beyond the fiscal year for which the budget was approved. Anticipated expenditures/obligations beyond the end of the current Owner's fiscal year budget shall be subject to budget approval. Any contract will be subject to and must contain a governmental non-appropriation of funds clause.
- 2.59. Cooperative Purchasing:** Purchases as a result of this solicitation are primarily for the City/County. Other governmental entities may be extended the opportunity to utilize the resultant contract award with the agreement of the successful provider and the participating agencies. All participating entities will be required to abide by the specifications, terms, conditions and pricings established in this Bid. The quantities furnished in this bid document are for only the City/County. It does not include quantities for any other jurisdiction. The City or County will be responsible only for the award for its jurisdiction. Other participating entities will place its own awards on its respective Purchase Orders through its purchasing office or use its purchasing card for purchase/payment as authorized or agreed upon between the provider and the individual entity. The City/County accepts no liability for payment of orders placed by other participating jurisdictions that choose to piggy-back on our solicitation. Orders placed by

participating jurisdictions under the terms of this solicitation will indicate its specific delivery and invoicing instructions.

- 2.60. Keep Jobs in Colorado Act:** Contractor shall be responsible for ensuring compliance with Article 17 of Title 8, Colorado Revised Statutes requiring 80% Colorado labor to be employed on public works. Contractor shall, upon reasonable notice provided by the Owner, permit the Owner to inspect documentation of identification and residency required by C.R.S. §8-17-101(2)(a). If Contractor claims it is entitled to a waiver pursuant to C.R.S. §8-17-101(1), Contractor shall state that there is insufficient Colorado labor to perform the Work such that compliance with Article 17 would create an undue burden that would substantially prevent a project from proceeding to completion and shall include evidence demonstrating the insufficiency and undue burden in its response.

Unless expressly granted a waiver by the Owner pursuant to C.R.S. §8-17-101(1), Contractor shall be responsible for ensuring compliance with Article 17 of Title 8, Colorado Revised Statutes requiring 80% Colorado labor to be employed on public Works. Contractor shall, upon reasonable notice provided by the Owner, permit the Owner to inspect documentation of identification and residency required by C.R.S. §8-17-101(2)(a).

2.60.1. "Public project" is defined as:

- (a) any construction, alteration, repair, demolition, or improvement of any land, building, structure, facility, road, highway, bridge, or other public improvement suitable for and intended for use in the promotion of the public health, welfare, or safety and any maintenance programs for the upkeep of such projects
- (b) for which appropriate or expenditure of moneys may be reasonably expected to be \$500,000.00 or more in the aggregate for any fiscal year
- (c) except any project that receives federal moneys.

3. Statement of Work

3.1. GENERAL / BACKGROUND: The City of Grand Junction is soliciting competitive bids from qualified and interested companies for all labor, equipment, and materials required to re-plaster and leak repair of the Lincoln Park-Moyer Swimming Pool. This aquatic facility contains a 75feet X 50-meter pool and 45 feet X 75 feet teaching pool, and a 350sq ft waterslide catch tank. The seasonal operations run from week before Memorial Day to Labor Day. All dimensions and scope of Work should be verified by Contractors prior to submission of bids.

3.2. SCOPE OF WORK:

- Contractor will saw cut 6" around all tile, embeds and below stainless-steel gutter. Remove all plaster down to concrete in these areas.
- Contractor will scarify entire pool surface with jackhammer or axe ensuring that there is an abrasion every four inches.

- Contractor will remove any loose pockets of plaster; these areas will be removed down to the concrete.
- Contractor will clean out plaster chips.
- Contractor will apply a concentrated acid bath to the walls and floor of the pool.
- Contractor will rinse and neutralize the total pool surface, and totally remove the diluted acid safely and completely from the pool.
- Contractor will remove all old sealant and re-seal all inlets, drains, visual cracks, and unions between gutter and plaster. Please specify product to be used for this process
- Contractor will re-plaster pool with standard marble plaster, using white tile to separate each day's Work.
- Contractor will replace all drain grates with VGB acceptable grates.
- Contractor will saw cut concrete around waterslide catch tank. Remove and replace 2" skimmer line and repair concrete when skimmer line has been replaced.
- Contractor will supervise the filling of pools.
- Contractor will specify appropriate chemical levels and initial maintenance schedule for new plaster.
- Upon completion of project Contractor will, in writing, give Grand Junction Parks and Recreation Department proper winterization procedure as not to void warranty.
- Contractor is responsible for all clean-up and disposal of necessary debris.

3.3. SPECIAL CONDITIONS & PROVISIONS:

3.3.1 Optional Pre-Bid Meeting: Prospective bidders are encouraged to attend an optional pre-bid meeting on January 24th at 1:30 PM. Meeting location shall be at the Lincoln Park – Moyer Pool, located at 1340 Gunnison Ave, Grand Junction, CO 81501. The purpose of this visit will be to inspect and to clarify the contents of this Invitation for Bids (IFB).

3.3.2 QUESTIONS REGARDING SOLICITATION PROCESS/SCOPE OF WORK:

Kassy Hackett, Buyer
City of Grand Junction
kassyh@gjcity.org

3.3.3 Project Manager: The Project Manager for the Project is Kirsten Armbruster, Project Engineer, who can be reached at (970) 244-1421. During Construction, all notices, letters, submittals, and other communications directed to the City shall be addressed and mailed or delivered to:

City of Grand Junction
Department of Public Works
Attn: Kirsten Armbruster, Project Manager
250 North Fifth Street
Grand Junction, CO 81501

3.3.4 Contract Administrator: The Contract Administrator for the Project is Duane Hoff Jr., Contract Administrator, who can be reached at (970)244-1545. During Construction, contract related inquiries, issues, and other communications shall be directed to:

Duane Hoff Jr., Contract Administrator
duaneh@gjcity.org

3.3.5 Pricing: Pricing shall be all inclusive to include but not be limited to: all labor, equipment, supplies, materials, freight (F.O.B. Destination – Freight Pre-paid and Allowed to each site), travel, mobilization costs, fuel, set-up and take down costs, and full-time inspection costs, and all other costs related to the successful completion of the project.

The Owner shall not pay nor be liable for any other additional costs including but not limited to: taxes, shipping charges, insurance, interest, penalties, termination payments, attorney fees, liquidated damages, etc.

3.3.6 Freight/Shipping: All freight/shipping shall be F.O.B. Destination – Freight Pre-Paid and Allowed to the project site(s), Grand Junction, CO.

Contractor must meet all federal, state, and local rules, regulations, and requirements for providing such Work.

3.3.7 Contract: A binding contract shall consist of: (1) the IFB and any amendments thereto, (2) Additional Documents as stated in Section 1.10, (3) the bidder's response (bid) to the IFB, (4) clarification of the bid, if any, and (5) the City's Purchasing Department's acceptance of the bid by "Notice of Award" or by "Purchase Order". All Exhibits and Attachments included In the IFB shall be incorporated into the contract by reference.

A. The contract expresses the complete agreement of the parties and, performance shall be governed solely by the specifications and requirements contained therein.

B. Any change to the contract, whether by modification and/or supplementation, must be accomplished by a formal contract amendment signed and approved by and between the duly authorized representative of the bidder and the City Purchasing Division or by a modified Purchase Order prior to the effective date of such modification. The bidder expressly and explicitly understands and agrees that no other method and/or no other document, including acts and oral communications by or from any person, shall be used or construed as an amendment or modification to the contract.

3.3.8 Time of Completion: The scheduled time of Completion for the Project is No Later Than May 1, 2023.

Completion is achieved when site cleanup and all punch list items (resulting from the final inspection) have been completed. Completion shall have the meaning set forth in Article I, Section 3 (Definitions and Terms) of the General Contract Conditions.

3.3.9 Working Days and Hours: The working days and hours shall be as stated in the General Contract Conditions or as mutually agreed upon in the preconstruction meeting with the following exception:

All Work shall be performed between the hours of 7:00 AM to 5:00 PM.

3.3.10 Licenses and Permits: Contractor is responsible for obtaining all necessary licenses and permits required for Construction, at Contractors expense. See Section 2.12. Contractor shall supply to Owner all copies of finalized permits.

3.3.11 Permits: The following permits are required for the Project and will be obtained by the City at no cost to the Contractor:

None

The following permits are required for the Project and shall be obtained and paid for by the Contractor, with the costs included in the total bid price for the Project:

None

3.3.12 Project Sign: Project signs, if any, will be furnished and installed by the City.

3.3.13 Authorized Representatives of the City: Those authorized to represent the City shall include Purchasing Agent, Engineers, and Inspectors employed by the City, only.

3.3.14 Stockpiling Materials and Equipment: All stockpiling/storage shall be in accordance with General Contract Condition Section 51.

3.3.15 Clean-Up: The Contractor is responsible for cleaning up all loose materials that have been deposited or swept into gutters, and onto sidewalks and driveways as a result of sidewalk operations. The costs for all clean-up Work shall be considered incidental and will not be paid for separately.

3.3.16 Excess Material: All excess materials shall be disposed in accordance with General Contract Condition Section 50.

3.3.17 Incidental Items: Any item of Work not specifically identified or paid for directly, but which is necessary for the satisfactory completion of any paid items of Work, will be considered as incidental to those items, and will be included in the cost of those items.

3.3.18 Work to be Performed by the City (Prior to Construction):

- City will drain pools slowly and make observation of the hydrostatic relief valve for any in coming water.

- City will supply ample hoses to fill pool.
- City will mist down walls with water during plastering and filling of pools.
- City will perform start-up of pool equipment at specified time, as specified by Contractor.
- City will perform post plastering maintenance as specified by Contractor (i.e., brushing and vacuuming of pools).
- City will maintain chemically balance water as specified by Contractor.

3.3.19 Existing Concrete Sidewalks, Pans, Fillets, Curbs and Gutters: The existing sidewalks, pans, fillets, curb and gutter are in good serviceable condition. In most instances the installation of new sidewalk and pavement will be adjacent to existing concrete. The Contractor will need to protect all concrete adjacent to construction. If the concrete is damaged during construction the Contractor will be responsible for its replacement at no cost to the City. The Contractor, the City Project Inspector, and/or the City Project Manager will walk and record any concrete that is deemed to be damaged before construction has started.

3.3.20 Safety Plan: Contractor shall submit to the City a Safety Management Plan prior to commencement of construction. Contractor shall provide protective barriers, fences, etc. to ensure the safety of pedestrians and vehicular traffic during the Work. All barriers and fences shall comply with local, state, and federal regulations and laws. The Contractor shall take precautions to ensure safety of people (including building users, passers-by, and workers) and protection of property (including adjacent building elements, landscaping, and motor vehicles).

3.4. Attachments:

- Appendix A: Lincoln Park Pool Site Plan & Roof Plan
- Appendix B: Lincoln Park Pool Site Grading & Drainage
- Appendix C: Lincoln Park Pool Main Pool Plan
- Appendix D: Lincoln Park Pool Other Sections Plans

3.5. Contractor Bid Documents: For Contractor's convenience, the following is a list of forms/items to be submitted with the Contractor's bid response. However, should a form/item not be listed in this section, but required in the solicitation documents, it is the Contractor's responsibility to ensure all forms/items are submitted.

- **Contractor's Bid Form**
- **Price Bid Schedule**
- **Warranty Information**
- **Safety Plan**

3.6. IFB TENTATIVE TIME SCHEDULE:

Invitation For Bids available	January 17, 2023
Optional Pre-Bid Meeting	January 24, 2023
Inquiry deadline, no questions after this date	January 31, 2023
Addendum Posted	February 2, 2023
Submittal deadline for proposals	February 8, 2023
City Council Approval	March 1, 2023
Notice of Award & Contract execution	March 2, 2023
Bonding & Insurance Cert due	March 10, 2023

Preconstruction meeting
Work begins no later than
Final Completion

TBD
After Notice to Proceed
May 1, 2023

4. Contractor's Bid Form

Bid Date: _____

Project: IFB-5177-23-KH "Lincoln Park-Moyer Pool Re-Plaster & Repair"

Bidding Company: _____

Name of Authorized Agent: _____

Email _____

Telephone _____ **Address** _____

City _____ **State** _____ **Zip** _____

The undersigned Bidder, in compliance with the Invitation for Bids, having examined the Instruction to Bidders, General Contract Conditions, Statement of Work, Specifications, and any and all Addenda thereto, having investigated the location of, and conditions affecting the proposed work, hereby proposes to furnish all labor, materials and supplies, and to perform all work for the Project in accordance with Contract Documents, within the time set forth and at the prices stated below. These prices are to cover all expenses incurred in performing the work required under the Contract Documents, of which this Contractor's Bid Form is a part.

The undersigned Contractor does hereby declare and stipulate that this offer is made in good faith without collusion or connection to any person(s) providing an offer for the same work, and that it is made in pursuance of, and subject to, all terms and conditions of the Instructions to Bidders, the Specifications, and all other Solicitation Documents, all of which have been examined by the undersigned.

The Contractor also agrees that if awarded the Contract, to provide insurance certificates within ten (10) working days of the date of Notification of Award. Submittal of this offer will be taken by the Owner as a binding covenant that the Contractor will be prepared to complete the project in its entirety.

The Owner reserves the right to make the award on the basis of the offer deemed most favorable, to waive any formalities or technicalities and to reject any or all offers. It is further agreed that this offer may not be withdrawn for a period of sixty (60) calendar days after closing time. Submission of clarifications and revised offers automatically establish a new thirty day (30) period.

Prices in the bid proposal have not knowingly been disclosed with another provider and will not be prior to award.

- Prices in this bid proposal have been arrived at independently, without consultation, communication or agreement for the purpose of restricting competition.
- No attempt has been made nor will be to induce any other person or Contractor to submit a bid proposal for the purpose of restricting competition.
- The individual signing this bid proposal certifies they are a legal agent of the offeror, authorized to represent the offeror and is legally responsible for the offer with regard to supporting documentation and prices provided.
- Direct purchases by the City of Grand Junction are tax exempt from Colorado Sales or Use Tax. Tax exempt No. 98-03544. The undersigned certifies that no Federal, State, County or Municipal tax will be added to the above quoted prices.
- City of Grand Junction payment terms shall be Net 30 days.
- Prompt payment discount of _____ percent of the net dollar will be offered to the Owner if the invoice is paid within _____ days after the receipt of the invoice. The Owner reserves the right to take into account any such discounts when determining the bid award that are no less than Net 10 days.

RECEIPT OF ADDENDA: the undersigned Contractor acknowledges receipt of Addenda to the Solicitation, Specifications, and other Contract Documents.

State number of Addenda received: _____.

It is the responsibility of the Bidder to ensure all Addenda have been received and acknowledged.

By signing below, the Undersigned agree to comply with all terms and conditions contained herein.

Company: _____

Authorized Signature: _____

Title: _____

The undersigned Bidder proposes to subcontract the following portion of Work:

<u>Name & address of Sub-Contractor</u>	<u>Description of work to be performed</u>	<u>% of Contract</u>
_____	_____	_____
_____	_____	_____
_____	_____	_____
_____	_____	_____

The undersigned Bidder acknowledges the right of the City to reject any and all Bids submitted and to waive informalities and irregularities therein in the City's sole discretion.

By submission of the Bid, each Bidder certifies, and in the case of a joint Bid each party thereto certifies as to its own organization, that this Bid has been arrived at independently, without collusion, consultation, communication, or agreement as to any matter relating to this Bid with any other Bidder or with any competitor.

PRICE BID SCHEDULE: IFB-5177-23-KH Lincoln Park-Moyer Pool Re-Plaster & Repair

Item No.	Description	Total Price
1	Total price for labor, materials, parts, freight, etc. to complete the re-plaster and leak repair of the Lincoln Park-Moyer Swimming Pool of the scope of work.	

Total Bid Price Written:

Product to be used for Section 3.2: _____

Standard Marble Plaster (Section 3.2)(Please Specify): _____

Warranty (Please Specify Warranty Provided): _____

By signing below, the Undersigned agree to comply with all terms and conditions contained herein.

Company: _____

Authorized Signature: _____

Title: _____

Appendix A: Lincoln Park Pool Site Plan & Roof Plan

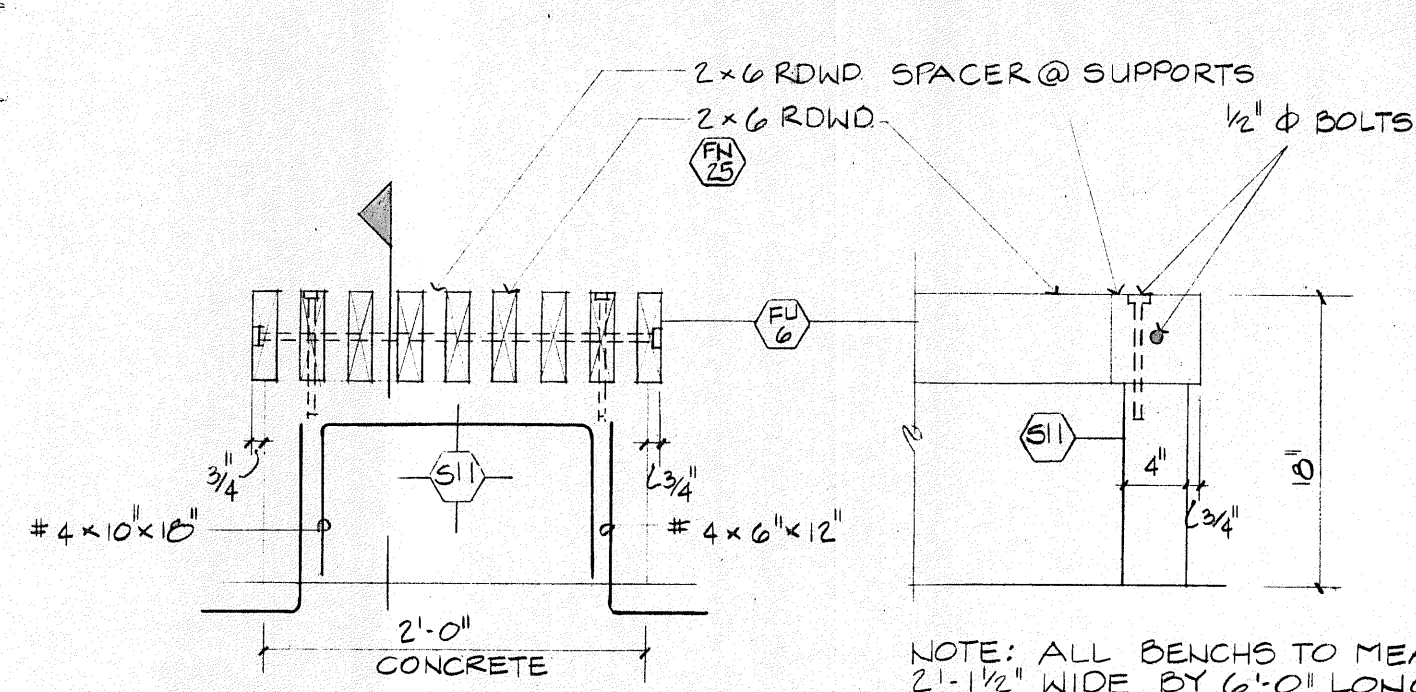

NOTE: ALL BENCHES TO MEASURE 21'-1/2" WIDE BY 6'-0" LONG W/ 3 CONC. SUPPORTS EA. END & AT SUPPORTS

1 BENCH DETAIL
1":1'-0"

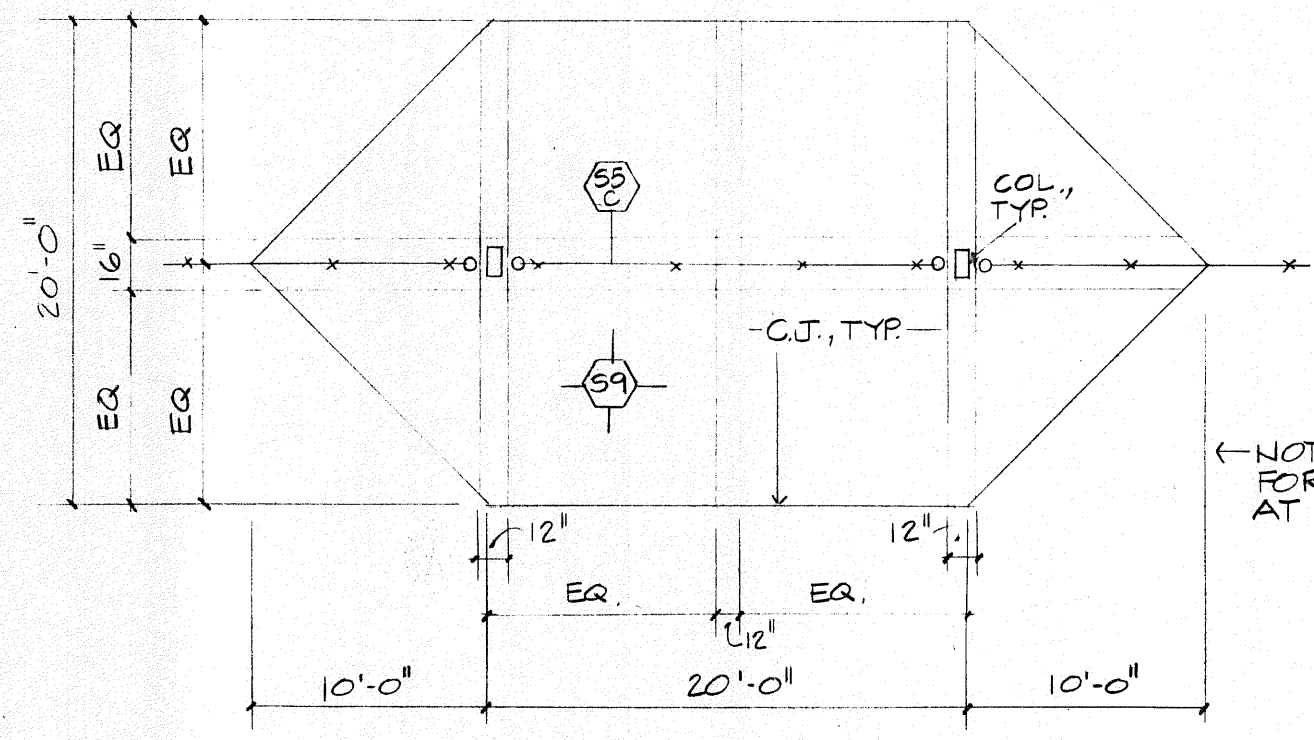

NOTE: SEE SITE PLAN FOR FENCE DIRECTION AT EA. CANOPY LOCATION.

2 CANOPY PAD DETAIL
1/8":1'-0"

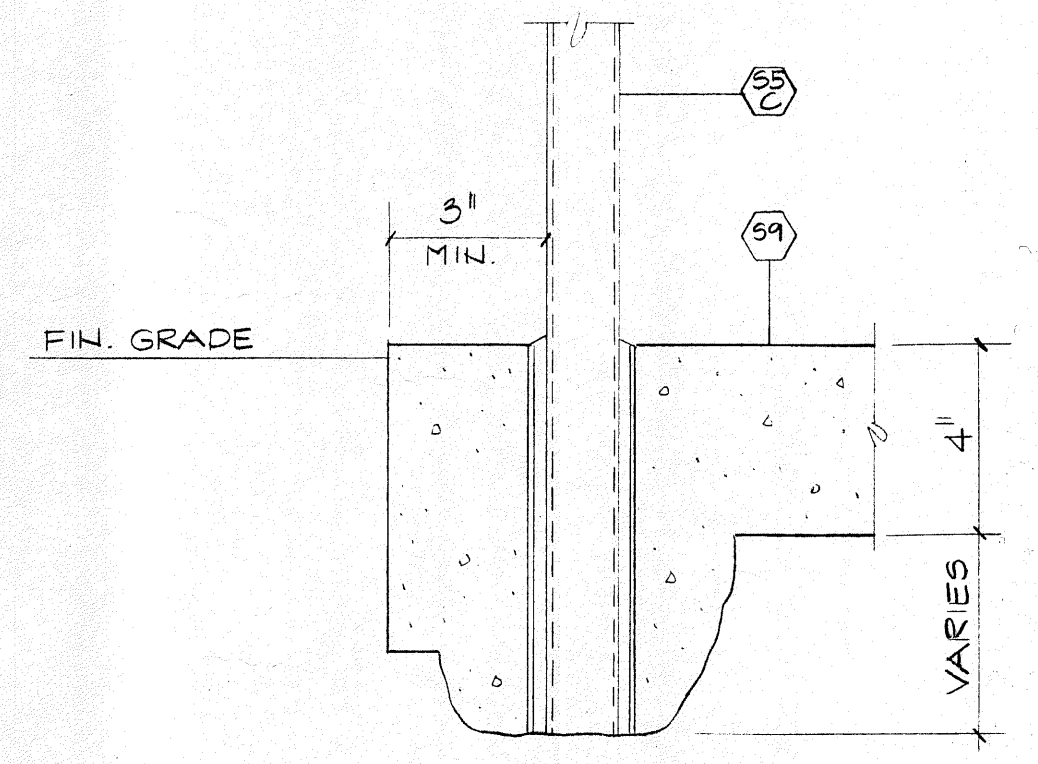

3 FENCE POST DETAIL
3":1'-0"

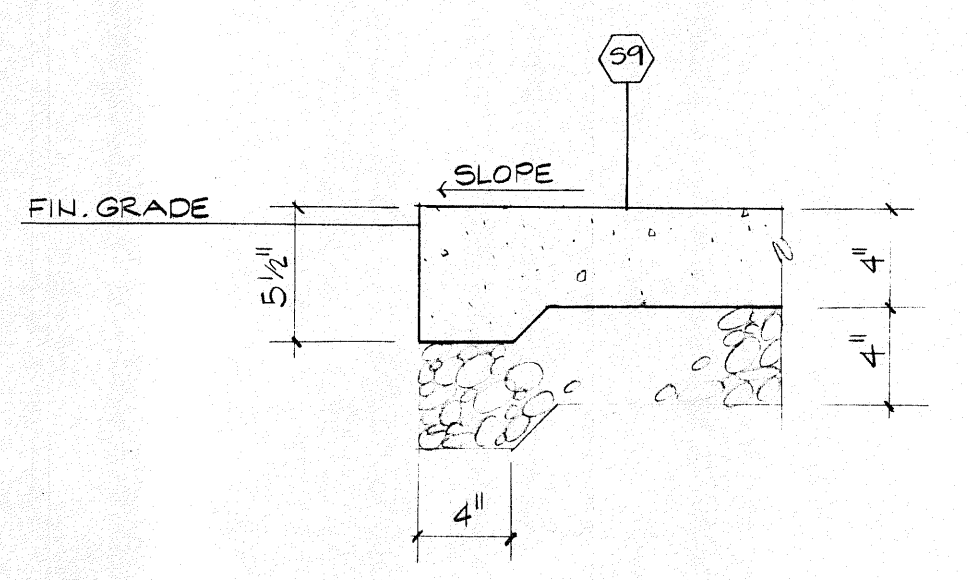

4 INTEGRAL CURB/WALK
1 1/2":1'-0"

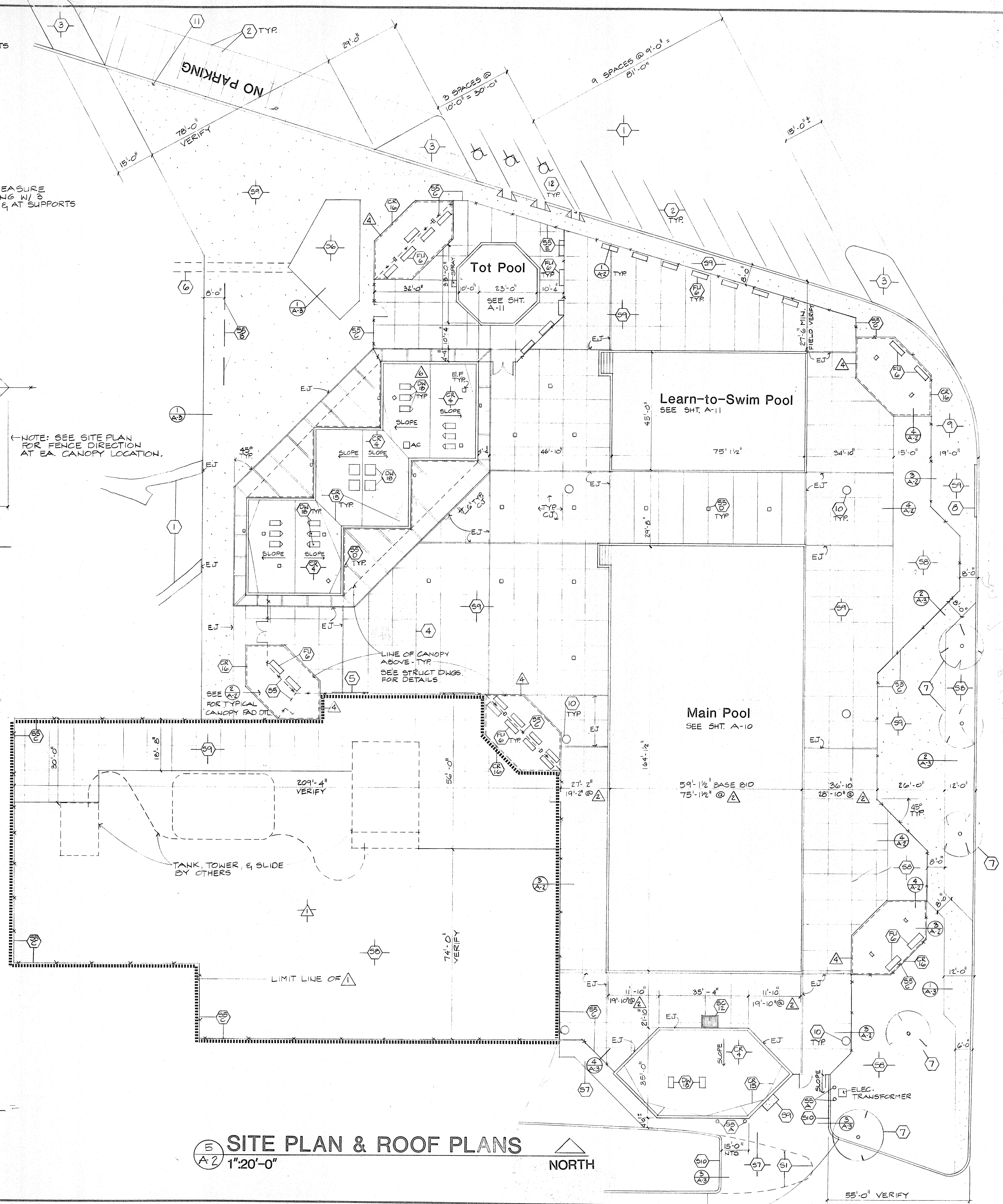

5 SITE PLAN & ROOF PLANS
1":20'-0"

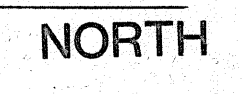

GENERAL SITE NOTES:

- 1 EXISTING ASPHALT TO REMAIN
- 2 2" PAINTED STRIPES ON ASPHALT
- 3 PAINT ON ASPHALT
- 4 BROOM FINISH CONCRETE. HERRINGBONE PATTERN
- 5 2 1/4" - 0" WIDE GATES
- 6 2 1/2" PVC SLEEVES
- 7 EXISTING TREES TO REMAIN
- 8 EXISTING BLOCK WALL TO REMAIN
- 9 LAYOUT OF CONTROL JOINTS IN CONCRETE WALK TO BE APPROVED BY ARCHITECT
- 10 LIGHT POLE BASE. AT FENCE LOCATIONS, OUTSIDE EDGE OF BASE TO BE LOCATED AT INSIDE OF FENCE LINE
- 11 SLOPE NEW WALK TO MATCH TOP OF EXISTING CONCRETE CURB
- 12 REMOVE 3'-0" OF CURB AND REPLACE WITH DRAIN SWALE AND RAMP IN SIDEWALK. TYPICAL 3 SPACES

SYSTEMS NOTES:

- S1 02050 DEMOLITION
- S5 SITE IMPROVEMENTS
 - A. 05010 CURB POSTS
 - B. BIKE RACKS BY OWNER
 - C. 02440 METAL FENCE AT 6'-0"
 - D. 15400 DRAINS
 - E. 02440 METAL FENCE AT 4'-0"
- S6 LANDSCAPING BY OWNER
- S7 PAVING
 - 02500 ASPHALT PAVING
 - 02200 4" STRUCTURE ROAD BASE COMPACTION
- S8 LANDSCAPING
 - 02480 SOIL PREPARATION
 - 02480 LAWN
 - 15050 SPRINKLER SYSTEM
- S9 CONCRETE SURFACING
 - 02200 4" COMPACTED STRUCTURE ROAD BASE
 - 03200 WELDED WIRE FABRIC
 - 03300 CAST-IN-PLACE CONCRETE
- S10 CONCRETE CURBS
 - 02200 4" COMPACTED STRUCTURE ROAD BASE
 - 03200 CONCRETE REINFORCING
 - 03300 CAST-IN-PLACE CONCRETE
- S11 MISCELLANEOUS CONCRETE
 - 03300 CAST-IN-PLACE CONCRETE
 - 03200 CONCRETE REINFORCING
- CR4 LIGHT WOOD FRAMING
 - 07500 MEMBRANE ROOFING
 - 06100 5/8" PLYWOOD
 - 06170 TJI JOISTS
 - 07200 10" BATT INSULATION
 - 07200 VAPOR BARRIER
 - 09250 5/8" MR GWB
- CR15 LIGHT WOOD FRAMING
 - 06100 5/8" PLYWOOD CRICKET
 - 06100 2 X SLEEPERS AT 16" OC
- CR16 METAL FRAMING
 - 07400 PREFORMED METAL ROOFING
 - 05010 STEEL FRAMING
- FN25 09900 WOOD SEALANT
- FU6 WOOD BENCH
 - 06200 MILLWORK
- SC12 05010 FIBERGLASS/METAL GRATING
- DW18 SKYLIGHTS
 - 07800 PLASTIC/ALUMINUM

DILLON-HUNT PC / ARCHITECTURE AND PROJECT MANAGEMENT
 804 GRAND AVENUE • GRAND JUNCTION, COLO 81501 • (303) 245-7383
LINCOLN PARK POOL

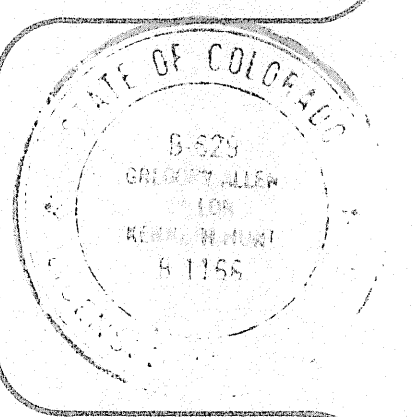

PROJECT NO: 0306
 DRAWN BY: KP
 DATE ISSUED: 08-30-06
 REVISIONS:

SHEET NO
A-2

△ TYPICAL ALTERNATE DESIGNATION SYMBOL

Appendix B: Lincoln Park Pool Site Grading & Drainage

GENERAL SITE NOTES:

- 1 EXISTING ASPHALT TO REMAIN
- 2 2" PAINTED STRIPES ON ASPHALT
- 3 PAINT ON ASPHALT
- 4 BROOM FINISH CONCRETE. HERRINGBONE PATTERN
- 5 2 1/4" - 0" WIDE GATES
- 6 2 1/2" PVC SLEEVES
- 7 EXISTING TREES TO REMAIN
- 8 EXISTING BLOCK WALL TO REMAIN
- 9 LAYOUT OF CONTROL JOINTS IN CONCRETE WALK TO BE APPROVED BY ARCHITECT
- 10 LIGHT POLE BASE. AT FENCE LOCATIONS, OUTSIDE EDGE OF BASE TO BE LOCATED AT INSIDE OF FENCE LINE
- 11 SLOPE NEW WALK TO MATCH TOP OF EXISTING CONCRETE CURB
- 12 REMOVE 3 1/2" OF CURB AND REPLACE WITH DRAIN SWALE AND RAMP IN SIDEWALK. TYPICAL 3 SPACES

SYSTEMS NOTES:

- S1 02050 DEMOLITION
- S5 SITE IMPROVEMENTS
 - A. 05010 GUARD POSTS
 - B. BIKE RACK BY OWNER
 - C. 02440 METAL FENCE AT 6'-0"
 - D. 15400 DRAINS
 - E. 02440 METAL FENCE AT 4'-0"
- S6 LANDSCAPING BY OWNER
- S7 PAVING
 - 02500 ASPHALT PAVING
 - 02200 4" COMPACTED STRUCTURE ROAD BASE
- S8 LANDSCAPING
 - 02480 SOIL PREPARATION
 - 02480 LAWN
 - 15050 SPRINKLER SYSTEM
- S9 CONCRETE SURFACING
 - 02200 4" COMPACTED STRUCTURE ROAD BASE
 - 03200 WELDED WIRE FABRIC
 - 03300 CAST-IN-PLACE CONCRETE
- S10 CONCRETE CURBS
 - 02200 4" COMPACTED STRUCTURE ROAD BASE
 - 03200 CONCRETE REINFORCING
 - 03300 CAST-IN-PLACE CONCRETE

1 INTEGRAL CURB/WALK
1 1/2":1'-0"

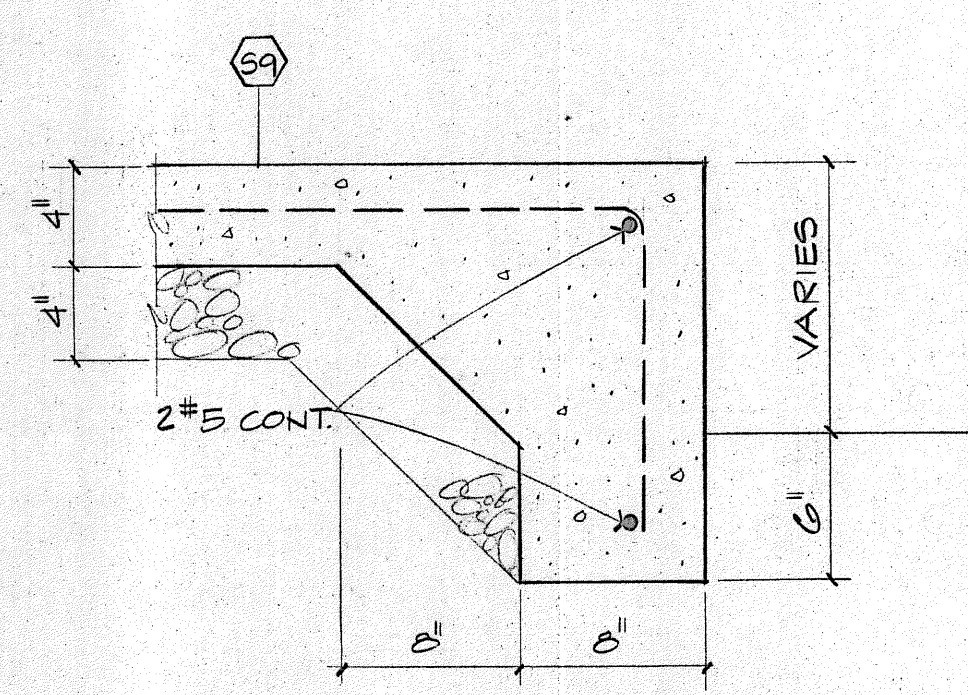

2 INTEGRAL WALK/WALL
1 1/2":1'-0"

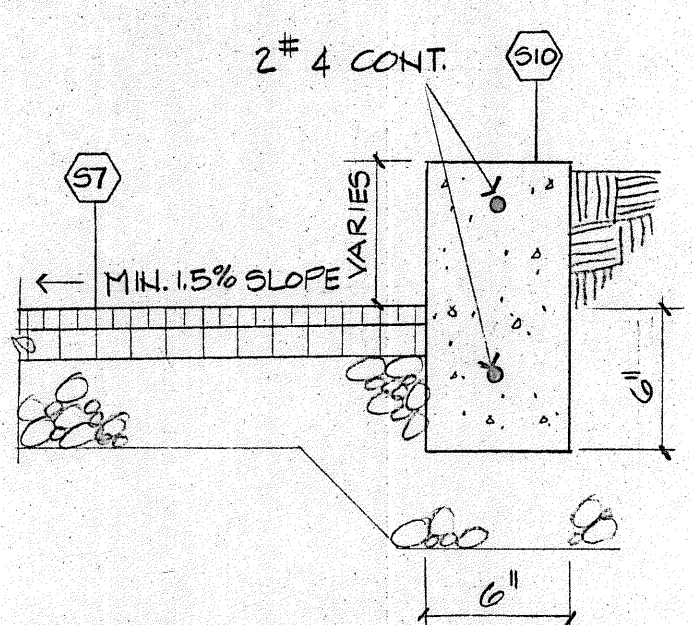

3 CONCRETE CURB DETAIL
1 1/2":1'-0"

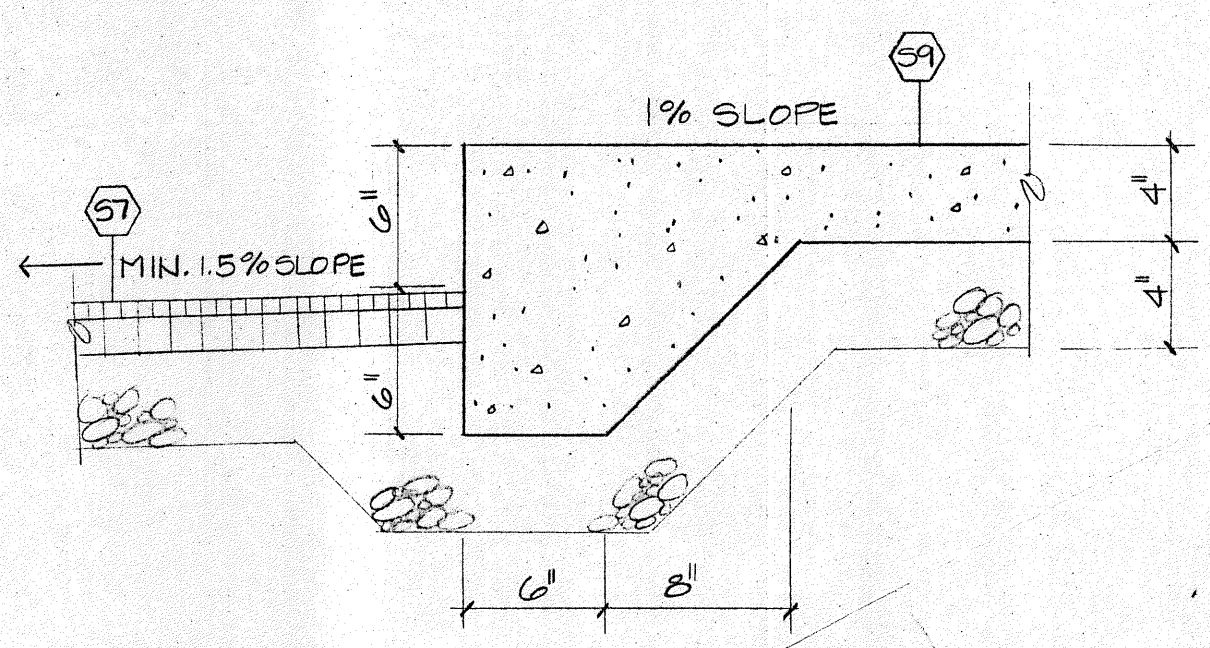

4 INTEGRAL CURB/WALK
1 1/2":1'-0"

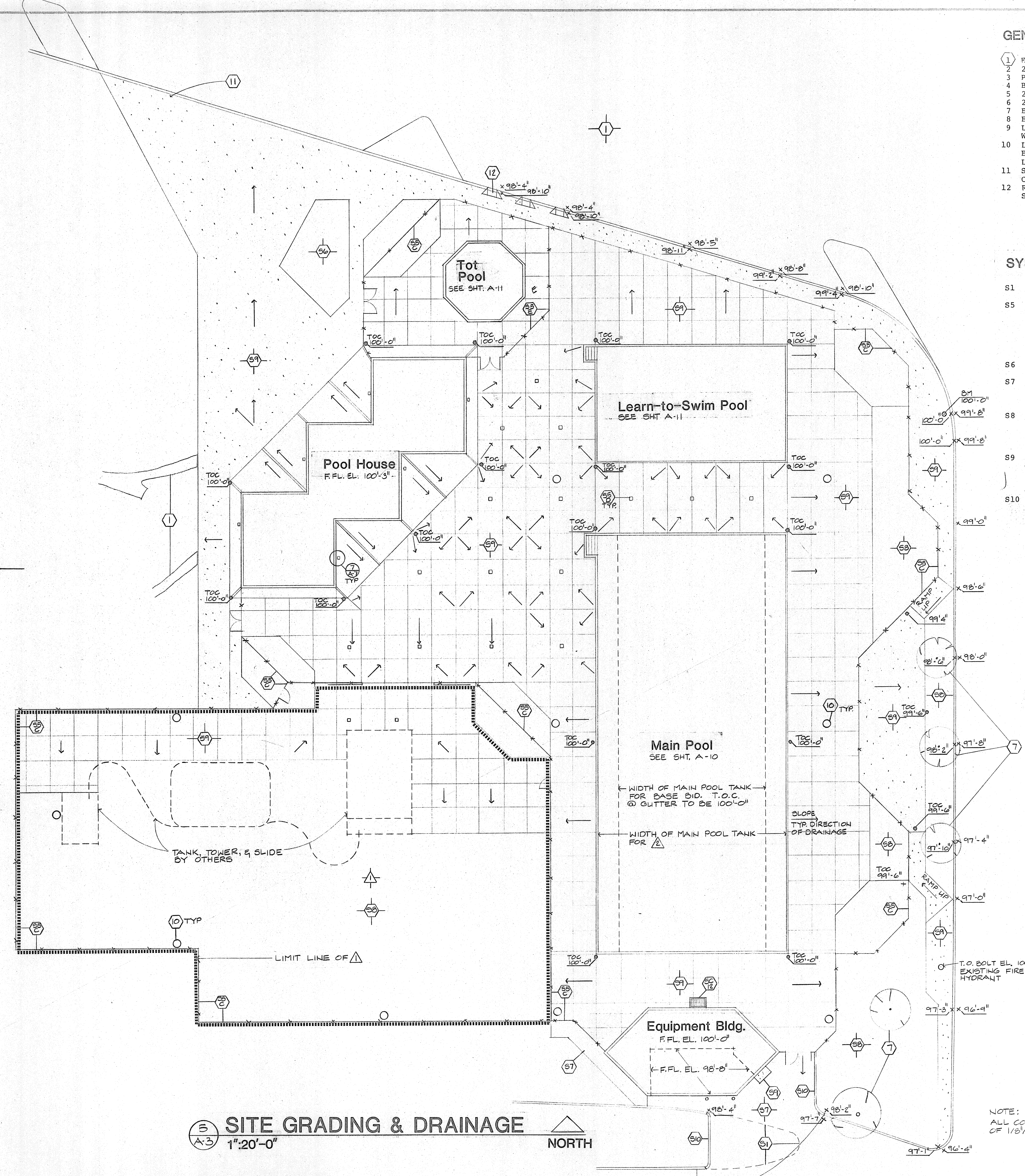

5 SITE GRADING & DRAINAGE
1":20'-0"

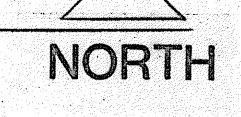

NOTE: ALL CONCRETE TO HAVE MIN. SLOPE OF 1/8"/FT. UNLESS NOTED OTHERWISE.

DILLON HUNT PC / ARCHITECTURE AND PROJECT MANAGEMENT
 804 GRAND AVENUE • GRAND JUNCTION, COLO 81501 • (303) 245-7383
LINCOLN PARK POOL

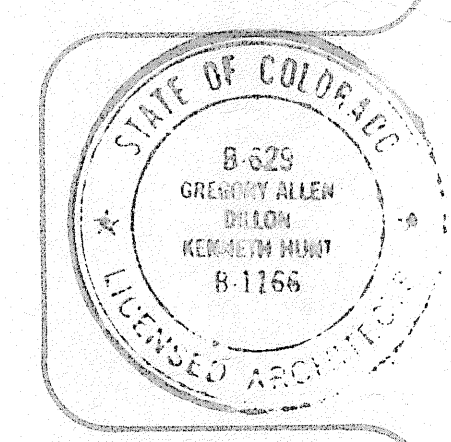

PROJECT NO. 0806
 DRAWN BY KP
 DATE ISSUED 08-30-08
 REVISIONS

SHEET NO. A-3

Appendix C: Lincoln Park Pool Main Pool Plan

Appendix D: Lincoln Park Pool Other Sections Plans

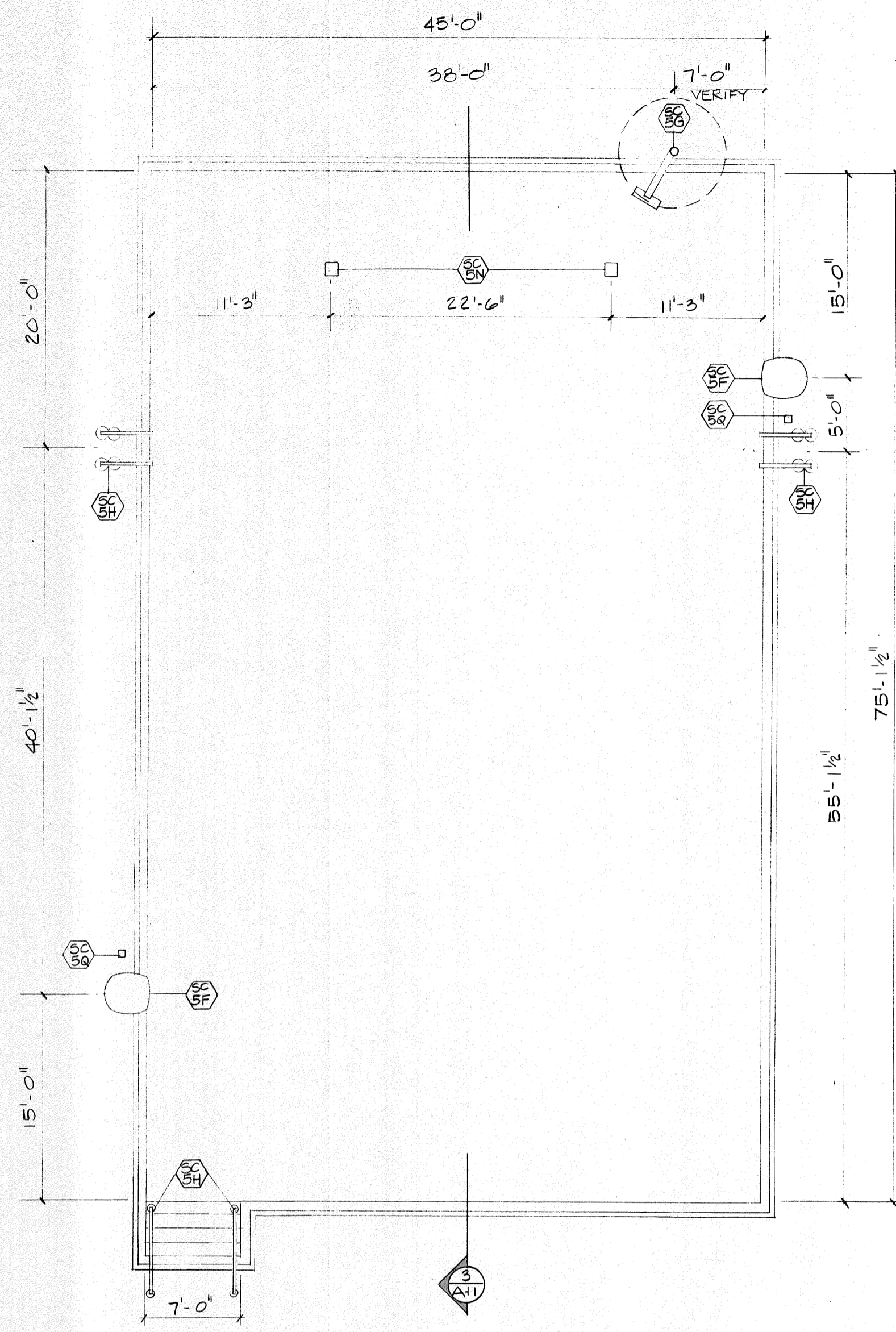

1 LEARN-TO-SWIM POOL PLAN
A-11 1/8":1'-0" NORTH

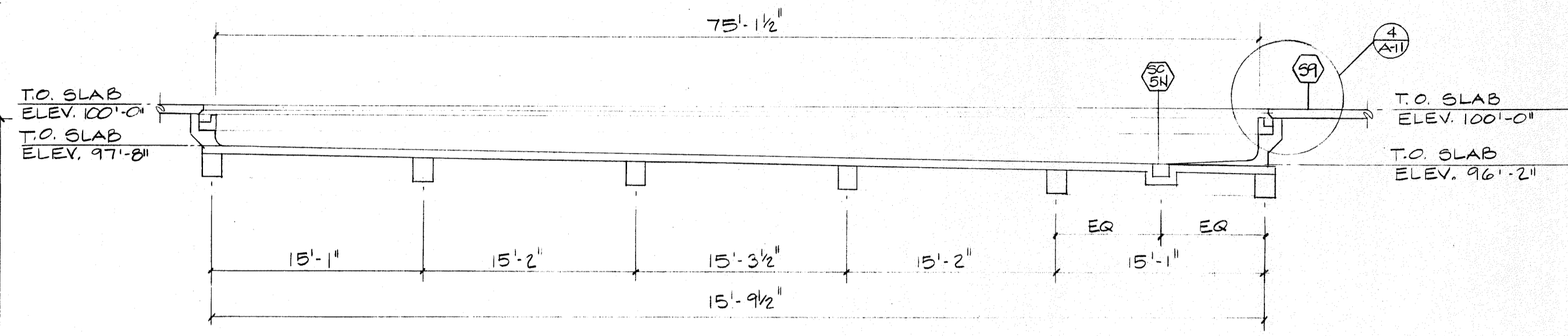

3 LEARN-TO-SWIM POOL SECTION
A-11 1/8":1'-0"

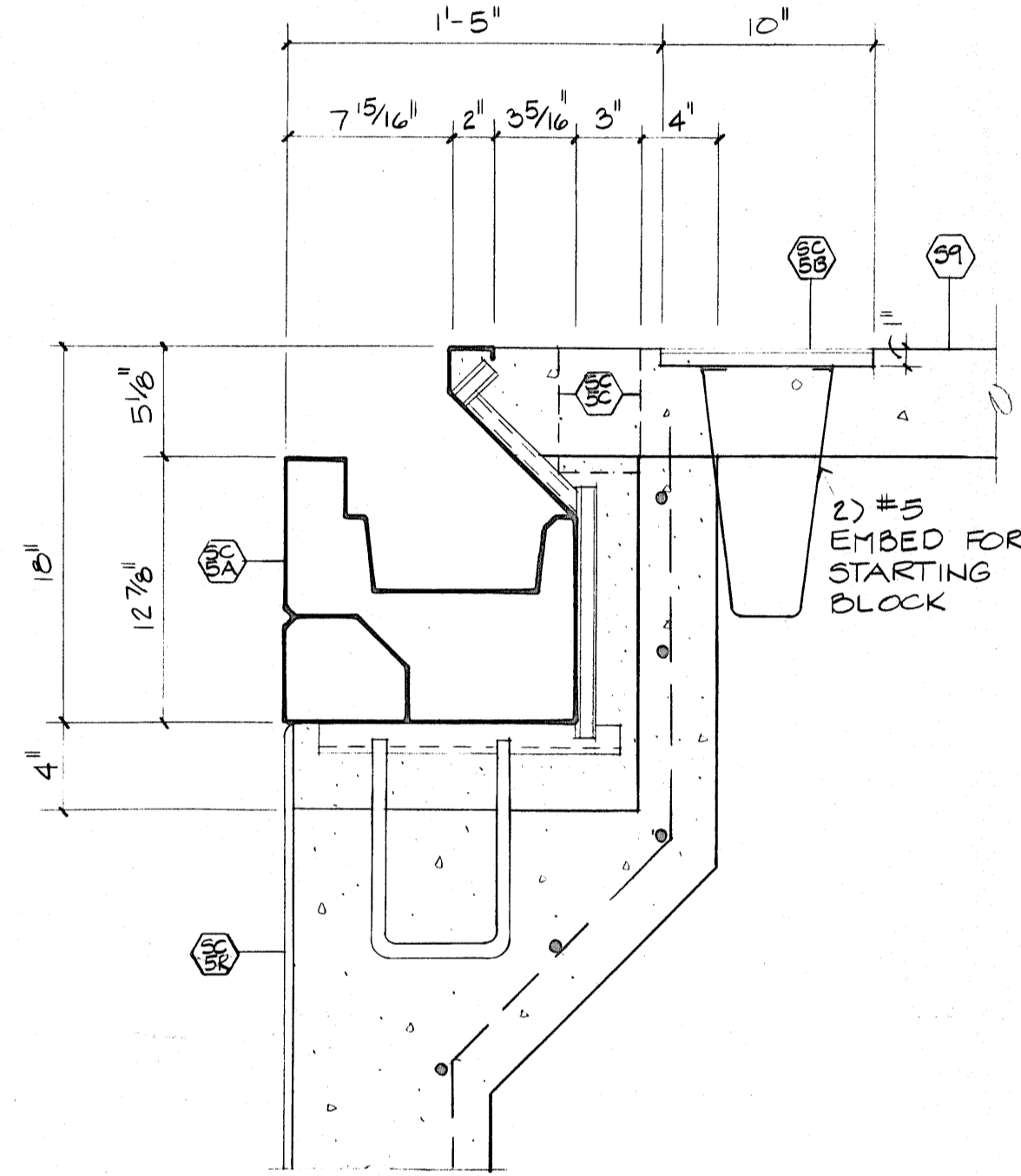

4 GUTTER DETAIL
A-11 1 1/2":1'-0"

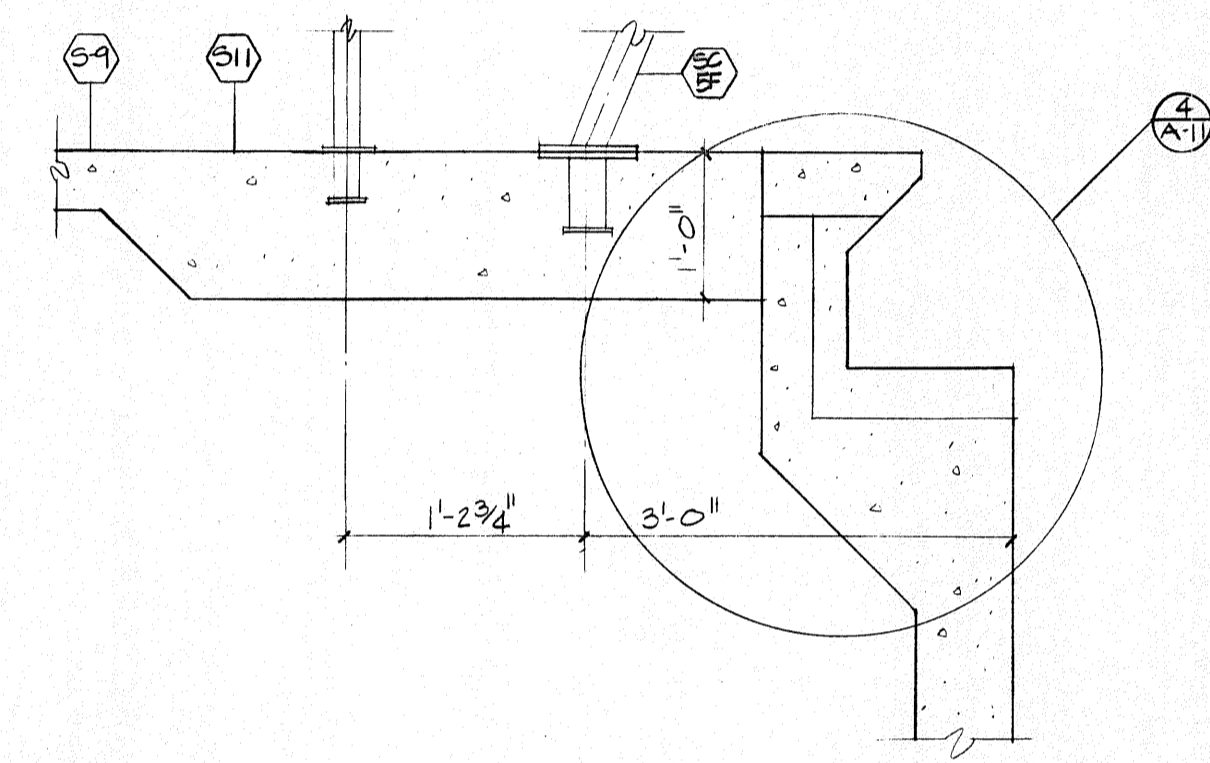

6 GUARD CHAIR
A-11 1/2":1'-0"

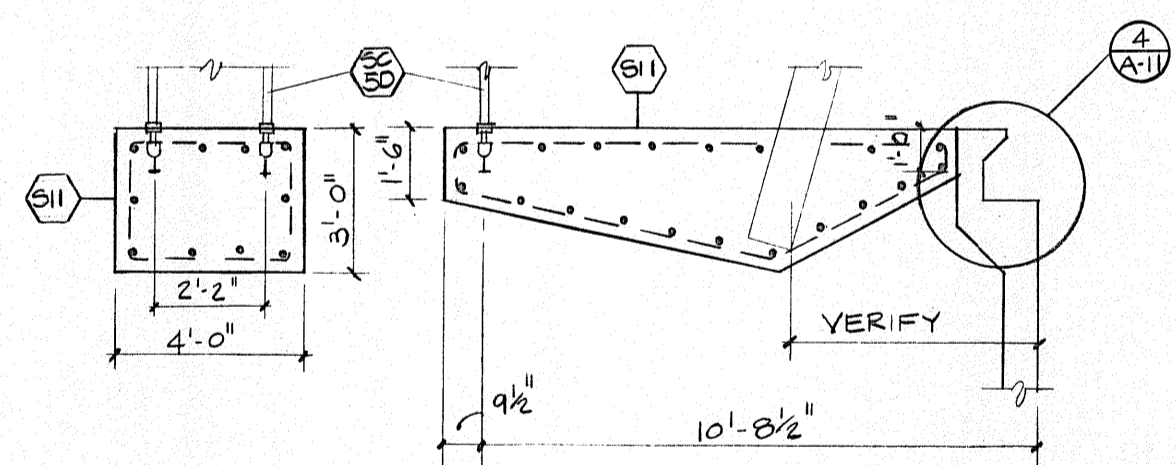

7 ONE METER BOARD
A-11 1/4":1'-0"

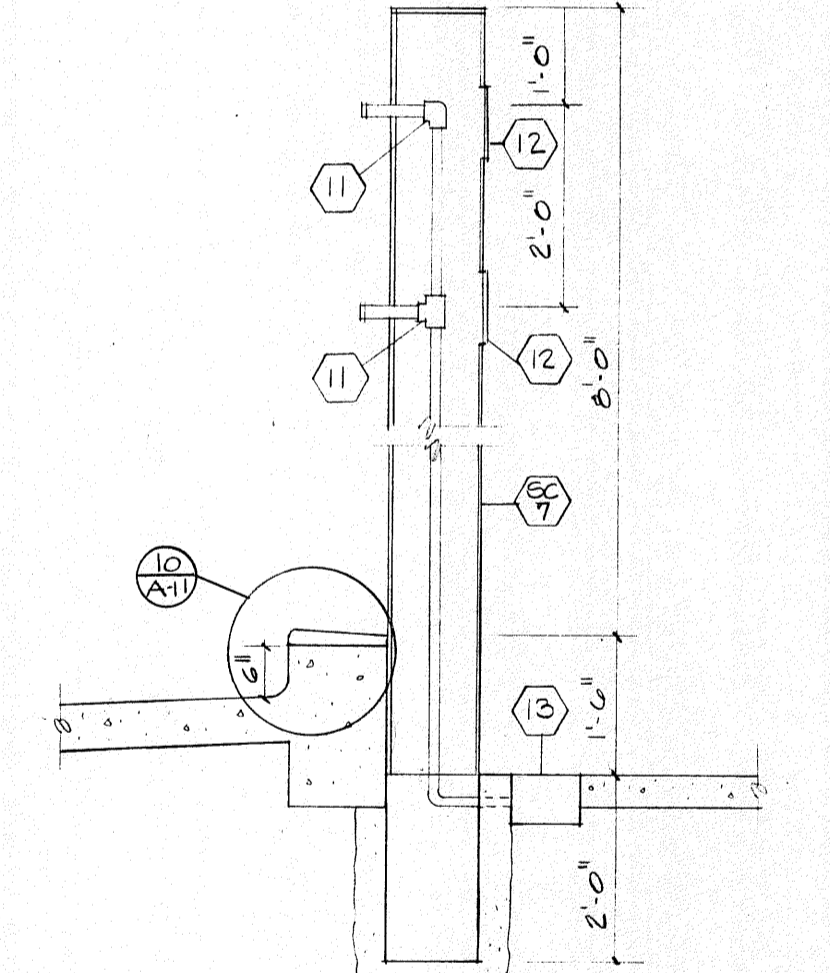

9 TOT SHOWER
A-11 1/2":1'-0"

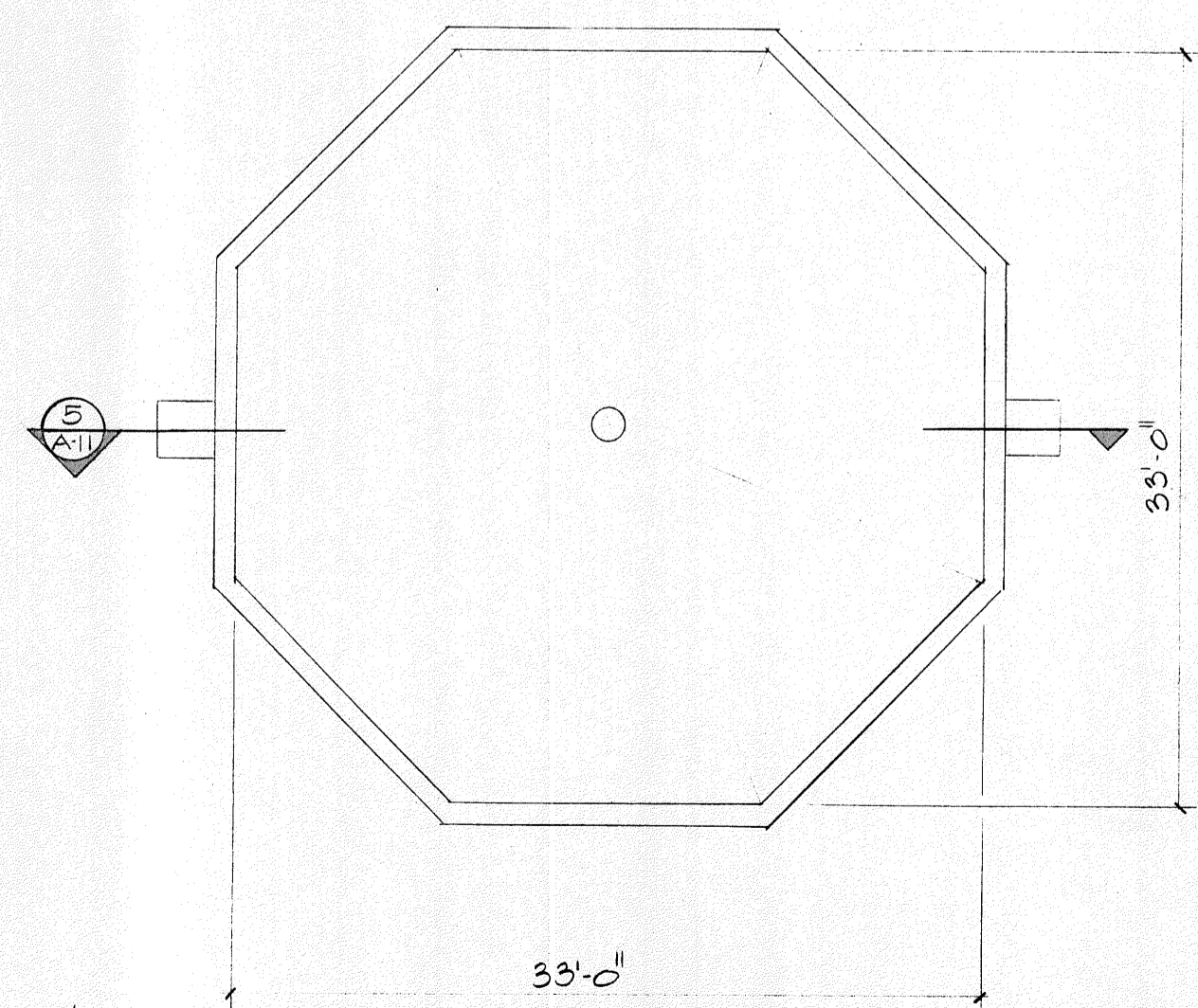

2 TOT POOL PLAN
A-11 1/8":1'-0"

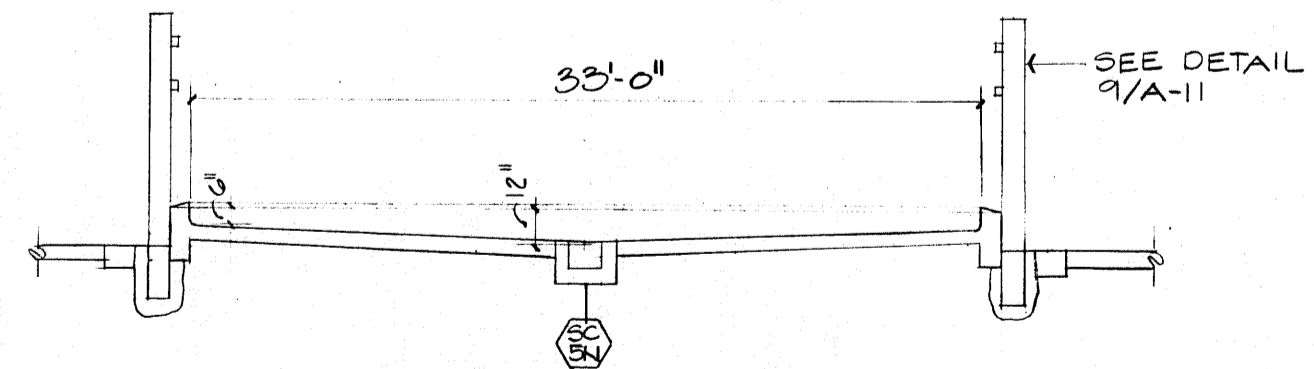

5 TOT POOL SECTION
A-11 1/8":1'-0"

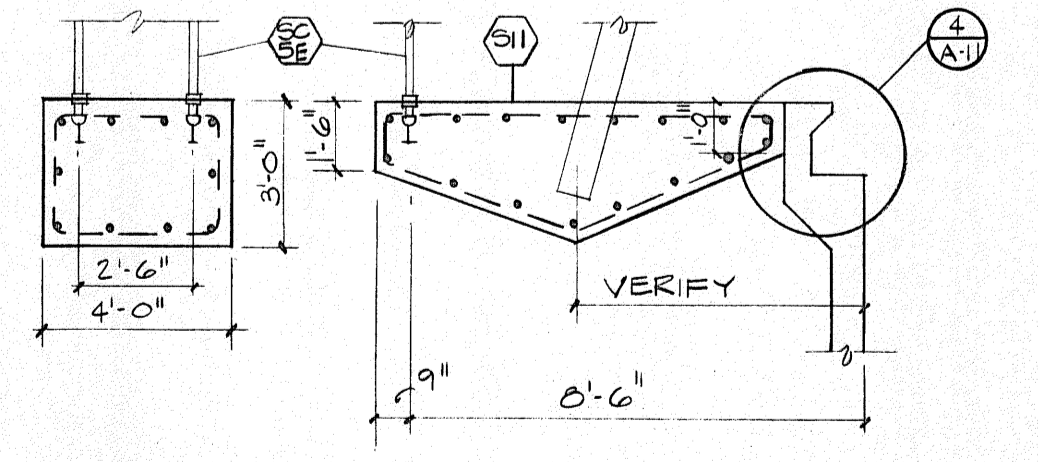

8 THREE METER BOARD
A-11 1/4":1'-0"

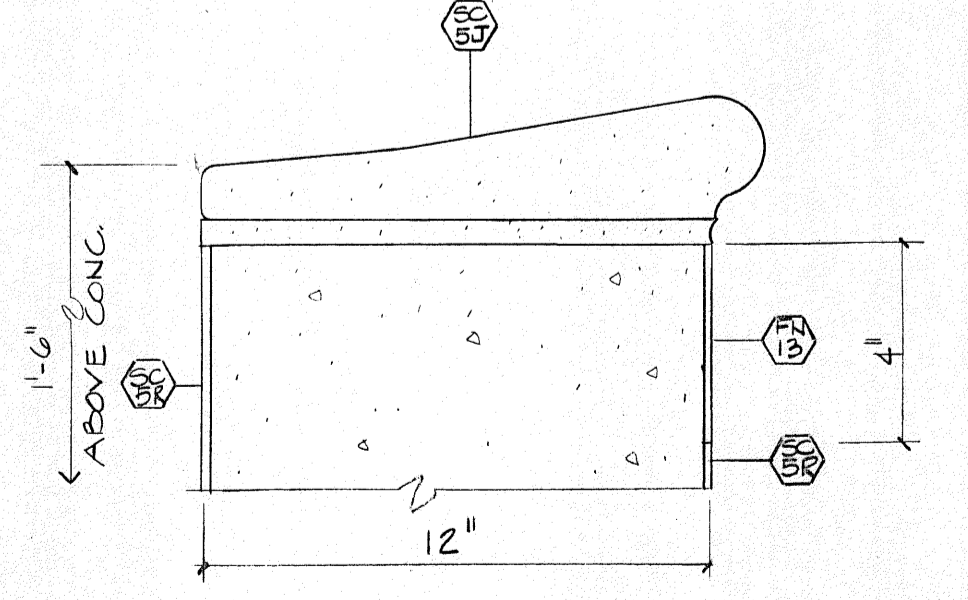

10 COPING DETAIL
A-11 3":1'-0"

GENERAL NOTES:

- 1 METAL LOCKERS TO BE FURNISHED AND INSTALLED BY OWNER.
- 2 COORDINATE LOCATION OF FLUSH VALVE/WALL PANEL WITH GRAB BARS.
- 3 EXTEND USABLE CABINET INTO CORNER.
- 4 ICEMAKER TO BE FURNISHED BY OWNER.
- 5 REFRIGERATOR TO BE FURNISHED BY OWNER.
- 6 GRILLE TO BE FURNISHED BY OWNER.
- 7 THREE ADJUSTABLE SHELVES. BOTTOM OF SHELF TO MEASURE 10" DEEP. UPPER SHELVES TO MEASURE 16" DEEP.
- 8 PLASTIC HOSE RACK - VERIFY MOUNTING HEIGHT.
- 9 16" DEEP STORAGE SHELVING W/ SHELVING STANDARDS AT 2'-0" OC.
- 10 METAL GRATING AT FLOOR. SEE MECHANICAL.
- 11 VALVE KEY. SEE MECHANICAL.
- 12 ACCESS PANEL FOR HAND HOLE. SEE MECHANICAL.
- 13 VALVE BOX. SEE MECHANICAL.
- 14 FOUNDATION DRAIN.
- 15 PROVIDE GWB AROUND ROOF PENETRATION FOR 3" MIN. CLEARANCE TO EXHAUST DUCT.

SYSTEMS NOTES:

- FD 02400 FOUNDATION DRAIN
- S9 CONCRETE SURFACING
02200 4" STRUCTURE ROAD BASE COMPACTION
03300 4" CAST-IN-PLACE CONCRETE
03200 WELDED WIRE FABRIC
- S11 MISCELLANEOUS CONCRETE
03200 CONCRETE REINFORCING
03300 CAST-IN-PLACE CONCRETE
- FN13 09300 CERAMIC TILE
- SC5 13150 SWIMMING POOL
A. S.S. GUTTER
B. STARTING BLOCK
C. DECK TIMER BOX
D. ONE METER DIVING BOARD
E. THREE METER DIVING BOARD
F. GUARD CHAIR
G. BODY LIFT
H. LADDER
J. COPING
K. POST EMBED
L. RACING LANE MARKER
M. LIFE LINE
N. MAIN DRAIN
P. WATER AGITATOR
Q. FLUSH HOSE BIB CONNECTION
R. PLASTERING
- SC7 05010 8" DIA. X 1/4" STL PIPE

DILLON HUNT PC / ARCHITECTURE AND PROJECT MANAGEMENT
 804 GRAND AVENUE • GRAND JUNCTION, COLO. 81501 • (303) 245-7383
LINCOLN PARK POOL



PROJECT NO. 0806
 DRAWN BY: KP
 DATE ISSUED: 08-30-05
 REVISIONS:



Purchasing Division

ADDENDUM NO. 1

DATE: February 2, 2023
FROM: City of Grand Junction Purchasing Division
TO: All Offerors
RE: Lincoln Park-Moyer Pool Re-Plaster & Repair IFB-5177-23-KH

Offerors responding to the above referenced solicitation are hereby instructed that the requirements have been clarified, modified, superseded and supplemented as to this date as hereinafter described.

Please make note of the following clarifications:

1. **Q:** Please verify that the City of Grand Junction does not want the racing lane tile removed and replaced.
A: We do not need the lane tiles removed or replaced.
2. **Q:** Could you provide the brand and model of the VGB grates/ covers to be replaced?
A: The City was unable to find the model and brand of the grates.
3. **Q:** Do you have a leak detection report for the pipe leak that leads to the waterslide catch tank?
A: The City has removed the slide catch tank from the scope. Please reference #8 in this addendum.
4. **Q:** Is the skimmer also leaking and or needs to be replaced?
A: The City has removed the skimmer from the scope. Please reference #8 in this addendum.
5. **Q:** Will the City of Grand Junction accept surface removal with a 40K PSI Hydroblaster as an alternative to axe chipping and acid washing to remove the old pool surface? Hydroblasting is an approved prep method by SGM and I have attached a brochure for your reference.
A: The City shall accept this alternative for surface removal.
6. **Q:** When was the plaster redone in the past?
A: The pool was re-plastered in 1992 and 2005.
7. **Q:** How wide are the existing cracks?
A: The City estimates the cracks to be around 1/8 in -1/4 in.
8. The following shall be removed from Section 3.2. Scope of Work:

- “Contractor will saw cut concrete around waterslide catch tank. Remove and replace 2” skimmer line and repair concrete when skimmer line has been replaced.”

The original solicitation for the project noted above is amended as noted.

All other conditions of subject remain the same.

Respectfully,

A handwritten signature in black ink, appearing to read "K. Hackett". The signature is written in a cursive style with a large initial "K".

Kassy Hackett, Buyer
City of Grand Junction, Colorado

4. Contractor's Bid Form

Bid Date: 02/08/2023

Project: IFB-5177-23-KH "Lincoln Park-Moyer Pool Re-Plaster & Repair"

Bidding Company: Mid-America Pool Renovation, Inc.

Name of Authorized Agent: Austin Kateusz

Email austin@poolrenovation.com

Telephone 816-994-3300 Address 5929 E 154th Terrace

City Grandview State MO Zip 64030

The undersigned Bidder, in compliance with the Invitation for Bids, having examined the Instruction to Bidders, General Contract Conditions, Statement of Work, Specifications, and any and all Addenda thereto, having investigated the location of, and conditions affecting the proposed work, hereby proposes to furnish all labor, materials and supplies, and to perform all work for the Project in accordance with Contract Documents, within the time set forth and at the prices stated below. These prices are to cover all expenses incurred in performing the work required under the Contract Documents, of which this Contractor's Bid Form is a part.

The undersigned Contractor does hereby declare and stipulate that this offer is made in good faith without collusion or connection to any person(s) providing an offer for the same work, and that it is made in pursuance of, and subject to, all terms and conditions of the Instructions to Bidders, the Specifications, and all other Solicitation Documents, all of which have been examined by the undersigned.

The Contractor also agrees that if awarded the Contract, to provide insurance certificates within ten (10) working days of the date of Notification of Award. Submittal of this offer will be taken by the Owner as a binding covenant that the Contractor will be prepared to complete the project in its entirety.

The Owner reserves the right to make the award on the basis of the offer deemed most favorable, to waive any formalities or technicalities and to reject any or all offers. It is further agreed that this offer may not be withdrawn for a period of sixty (60) calendar days after closing time. Submission of clarifications and revised offers automatically establish a new thirty day (30) period.

Prices in the bid proposal have not knowingly been disclosed with another provider and will not be prior to award.

- Prices in this bid proposal have been arrived at independently, without consultation, communication or agreement for the purpose of restricting competition.
- No attempt has been made nor will be to induce any other person or Contractor to submit a bid proposal for the purpose of restricting competition.
- The individual signing this bid proposal certifies they are a legal agent of the offeror, authorized to represent the offeror and is legally responsible for the offer with regard to supporting documentation and prices provided.
- Direct purchases by the City of Grand Junction are tax exempt from Colorado Sales or Use Tax. Tax exempt No. 98-03544. The undersigned certifies that no Federal, State, County or Municipal tax will be added to the above quoted prices.
- City of Grand Junction payment terms shall be Net 30 days.
- Prompt payment discount of _____ percent of the net dollar will be offered to the Owner if the invoice is paid within _____ days after the receipt of the invoice. The Owner reserves the right to take into account any such discounts when determining the bid award that are no less than Net 10 days.

RECEIPT OF ADDENDA: the undersigned Contractor acknowledges receipt of Addenda to the Solicitation, Specifications, and other Contract Documents.

State number of Addenda received: 1

It is the responsibility of the Bidder to ensure all Addenda have been received and acknowledged.

By signing below, the Undersigned agree to comply with all terms and conditions contained herein.

Company: Mid-America Pool Renovation, Inc.

Authorized Signature:  Austin Kateusz

Title: President

The undersigned Bidder proposes to subcontract the following portion of Work:

<u>Name & address of Sub-Contractor</u>	<u>Description of work to be performed</u>	<u>% of Contract</u>
No subcontractors to be used.	N/A	0

The undersigned Bidder acknowledges the right of the City to reject any and all Bids submitted and to waive informalities and irregularities therein in the City's sole discretion.

By submission of the Bid, each Bidder certifies, and in the case of a joint Bid each party thereto certifies as to its own organization, that this Bid has been arrived at independently, without collusion, consultation, communication, or agreement as to any matter relating to this Bid with any other Bidder or with any competitor.

PRICE BID SCHEDULE: IFB-5177-23-KH Lincoln Park-Moyer Pool Re-Plaster & Repair

Item No.	Description	Total Price
1	Total price for labor, materials, parts, freight, etc. to complete the re-plaster and leak repair of the Lincoln Park-Moyer Swimming Pool of the scope of work.	\$438,000.00

Total Bid Price Written:

Four Hundred Thirty-Eight Thousand Dollars.

Product to be used for Section 3.2: _____

Laticrete Latasil - See Attached Product Data Sheet.

Standard Marble Plaster (Section 3.2)(Please Specify): _____

Imerys Pool Mix and Lehigh Cement. See Attached Product Data Sheets.

Warranty (Please Specify Warranty Provided): _____

5 years - See Attached Sample Warranty.

By signing below, the Undersigned agree to comply with all terms and conditions contained herein.

Company: Mid-America Pool Renovation, Inc.

Authorized Signature:  _____ **Austin Kateusz**

Title: President



AIA Document A312™ – 2010

Performance Bond

Bond Number: UCSX158X-1235

CONTRACTOR:

(Name, legal status and address)

Mid America Pool Renovations, Inc.
5929 E 154th Terrace
Grandview, MO 64030

OWNER:

(Name, legal status and address)

City of Grand Junction, CO
910 Main St.
Grand Junction, CO 81501

CONSTRUCTION CONTRACT

Date: 3/27/2023

Amount: 408,000.00

Description:

(Name and location)

Lincoln Park-Moyer Pool Re-Plaster & Repair IFB-5177-23-KH

BOND

Date: 04/10/2023

(Not earlier than Construction Contract Date)

Amount: 408,000.00

Modifications to this Bond: None See Section 16

CONTRACTOR AS PRINCIPAL

Company: *(Corporate Seal)*

Mid America Pool Renovations, Inc.

Signature: [Signature]

Name

and Title: President

(Any additional signatures appear on the last page of this Performance Bond.)

SURETY

Company: *(Corporate Seal)*

United Casualty and Surety Insurance Company

Signature: [Signature]

Name

and Title: Stefan E. Tauger, Attorney In Fact



This document has important legal consequences. Consultation with an attorney is encouraged with respect to its completion or modification.

Any singular reference to Contractor, Surety, Owner or other party shall be considered plural where applicable.

AIA Document A312-2010 combines two separate bonds, a Performance Bond and a Payment Bond, into one form. This is not a single combined Performance and Payment Bond.

(FOR INFORMATION ONLY — Name, address and telephone)

AGENT or BROKER:

OWNER'S REPRESENTATIVE:

(Architect, Engineer or other party:)

§ 1 The Contractor and Surety, jointly and severally, bind themselves, their heirs, executors, administrators, successors and assigns to the Owner for the performance of the Construction Contract, which is incorporated herein by reference.

§ 2 If the Contractor performs the Construction Contract, the Surety and the Contractor shall have no obligation under this Bond, except when applicable to participate in a conference as provided in Section 3.

§ 3 If there is no Owner Default under the Construction Contract, the Surety's obligation under this Bond shall arise after

- .1 the Owner first provides notice to the Contractor and the Surety that the Owner is considering declaring a Contractor Default. Such notice shall indicate whether the Owner is requesting a conference among the Owner, Contractor and Surety to discuss the Contractor's performance. If the Owner does not request a conference, the Surety may, within five (5) business days after receipt of the Owner's notice, request such a conference. If the Surety timely requests a conference, the Owner shall attend. Unless the Owner agrees otherwise, any conference requested under this Section 3.1 shall be held within ten (10) business days of the Surety's receipt of the Owner's notice. If the Owner, the Contractor and the Surety agree, the Contractor shall be allowed a reasonable time to perform the Construction Contract, but such an agreement shall not waive the Owner's right, if any, subsequently to declare a Contractor Default;
- .2 the Owner declares a Contractor Default, terminates the Construction Contract and notifies the Surety; and
- .3 the Owner has agreed to pay the Balance of the Contract Price in accordance with the terms of the Construction Contract to the Surety or to a contractor selected to perform the Construction Contract.

§ 4 Failure on the part of the Owner to comply with the notice requirement in Section 3.1 shall not constitute a failure to comply with a condition precedent to the Surety's obligations, or release the Surety from its obligations, except to the extent the Surety demonstrates actual prejudice.

§ 5 When the Owner has satisfied the conditions of Section 3, the Surety shall promptly and at the Surety's expense take one of the following actions:

§ 5.1 Arrange for the Contractor, with the consent of the Owner, to perform and complete the Construction Contract;

§ 5.2 Undertake to perform and complete the Construction Contract itself, through its agents or independent contractors;

§ 5.3 Obtain bids or negotiated proposals from qualified contractors acceptable to the Owner for a contract for performance and completion of the Construction Contract, arrange for a contract to be prepared for execution by the Owner and a contractor selected with the Owner's concurrence, to be secured with performance and payment bonds executed by a qualified surety equivalent to the bonds issued on the Construction Contract, and pay to the Owner the amount of damages as described in Section 7 in excess of the Balance of the Contract Price incurred by the Owner as a result of the Contractor Default; or

§ 5.4 Waive its right to perform and complete, arrange for completion, or obtain a new contractor and with reasonable promptness under the circumstances:

- .1 After investigation, determine the amount for which it may be liable to the Owner and, as soon as practicable after the amount is determined, make payment to the Owner; or
- .2 Deny liability in whole or in part and notify the Owner, citing the reasons for denial.

§ 6 If the Surety does not proceed as provided in Section 5 with reasonable promptness, the Surety shall be deemed to be in default on this Bond seven days after receipt of an additional written notice from the Owner to the Surety demanding that the Surety perform its obligations under this Bond, and the Owner shall be entitled to enforce any remedy available to the Owner. If the Surety proceeds as provided in Section 5.4, and the Owner refuses the payment or the Surety has denied liability, in whole or in part, without further notice the Owner shall be entitled to enforce any remedy available to the Owner.

§ 7 If the Surety elects to act under Section 5.1, 5.2 or 5.3, then the responsibilities of the Surety to the Owner shall not be greater than those of the Contractor under the Construction Contract, and the responsibilities of the Owner to the Surety shall not be greater than those of the Owner under the Construction Contract. Subject to the commitment by the Owner to pay the Balance of the Contract Price, the Surety is obligated, without duplication, for

- .1 the responsibilities of the Contractor for correction of defective work and completion of the Construction Contract;
- .2 additional legal, design professional and delay costs resulting from the Contractor's Default, and resulting from the actions or failure to act of the Surety under Section 5; and
- .3 liquidated damages, or if no liquidated damages are specified in the Construction Contract, actual damages caused by delayed performance or non-performance of the Contractor.

§ 8 If the Surety elects to act under Section 5.1, 5.3 or 5.4, the Surety's liability is limited to the amount of this Bond.

§ 9 The Surety shall not be liable to the Owner or others for obligations of the Contractor that are unrelated to the Construction Contract, and the Balance of the Contract Price shall not be reduced or set off on account of any such unrelated obligations. No right of action shall accrue on this Bond to any person or entity other than the Owner or its heirs, executors, administrators, successors and assigns.

§ 10 The Surety hereby waives notice of any change, including changes of time, to the Construction Contract or to related subcontracts, purchase orders and other obligations.

§ 11 Any proceeding, legal or equitable, under this Bond may be instituted in any court of competent jurisdiction in the location in which the work or part of the work is located and shall be instituted within two years after a declaration of Contractor Default or within two years after the Contractor ceased working or within two years after the Surety refuses or fails to perform its obligations under this Bond, whichever occurs first. If the provisions of this Paragraph are void or prohibited by law, the minimum period of limitation available to sureties as a defense in the jurisdiction of the suit shall be applicable.

§ 12 Notice to the Surety, the Owner or the Contractor shall be mailed or delivered to the address shown on the page on which their signature appears.

§ 13 When this Bond has been furnished to comply with a statutory or other legal requirement in the location where the construction was to be performed, any provision in this Bond conflicting with said statutory or legal requirement shall be deemed deleted herefrom and provisions conforming to such statutory or other legal requirement shall be deemed incorporated herein. When so furnished, the intent is that this Bond shall be construed as a statutory bond and not as a common law bond.

§ 14 Definitions

§ 14.1 **Balance of the Contract Price.** The total amount payable by the Owner to the Contractor under the Construction Contract after all proper adjustments have been made, including allowance to the Contractor of any amounts received or to be received by the Owner in settlement of insurance or other claims for damages to which the Contractor is entitled, reduced by all valid and proper payments made to or on behalf of the Contractor under the Construction Contract.

§ 14.2 **Construction Contract.** The agreement between the Owner and Contractor identified on the cover page, including all Contract Documents and changes made to the agreement and the Contract Documents.

§ 14.3 **Contractor Default.** Failure of the Contractor, which has not been remedied or waived, to perform or otherwise to comply with a material term of the Construction Contract.

§ 14.4 **Owner Default.** Failure of the Owner, which has not been remedied or waived, to pay the Contractor as required under the Construction Contract or to perform and complete or comply with the other material terms of the Construction Contract.

§ 14.5 **Contract Documents.** All the documents that comprise the agreement between the Owner and Contractor.

§ 15 If this Bond is issued for an agreement between a Contractor and subcontractor, the term Contractor in this Bond shall be deemed to be Subcontractor and the term Owner shall be deemed to be Contractor.

§ 16 Modifications to this bond are as follows:

(Space is provided below for additional signatures of added parties, other than those appearing on the cover page.)

CONTRACTOR AS PRINCIPAL

SURETY

Company:

(Corporate Seal)

Company:

(Corporate Seal)

Signature: _____

Name and Title:

Address

Signature: _____

Name and Title:

Address

CAUTION: You should sign an original AIA Contract Document, on which this text appears in RED. An original assures that changes will not be obscured.

AIA[®] Document A312[™] – 2010

Payment Bond

Bond Number: UCSX158X-1235

CONTRACTOR:

(Name, legal status and address)

Mid America Pool Renovations, Inc.

5929 E 154th Terrace

Grandview, MO 64030

OWNER:

(Name, legal status and address)

City of Grand Junction, CO

910 Main St.

Grand Junction, CO 81501

CONSTRUCTION CONTRACT

Date: 3/27/2023

Amount: 408,000.00

Description:

(Name and location)

Lincoln Park-Moyer Pool Re-Plaster & Repair IFB-5177-23-KH

BOND

Date: 04/10/2023

(Not earlier than Construction Contract Date)

Amount: 408,000.00

Modifications to this Bond: None See Section 18

CONTRACTOR AS PRINCIPAL

Company: *(Corporate Seal)*

Mid America Pool Renovations, Inc.

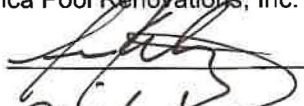
Signature: 

Name

and Title: *President*

(Any additional signatures appear on the last page of this Payment Bond.)

SURETY

Company: *(Corporate Seal)*

United Casualty and Surety Insurance Company

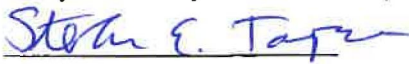
Signature: 

Name

and Title:

Stefan E. Tauger, Attorney In Fact

(FOR INFORMATION ONLY — Name, address and telephone)

AGENT or BROKER:

OWNER'S REPRESENTATIVE:

(Architect, Engineer or other party:)

This document has important legal consequences. Consultation with an attorney is encouraged with respect to its completion or modification.

Any singular reference to Contractor, Surety, Owner or other party shall be considered plural where applicable.

AIA Document A312-2010 combines two separate bonds, a Performance Bond and a Payment Bond, into one form. This is not a single combined Performance and Payment Bond.



§ 1 The Contractor and Surety, jointly and severally, bind themselves, their heirs, executors, administrators, successors and assigns to the Owner to pay for labor, materials and equipment furnished for use in the performance of the Construction Contract, which is incorporated herein by reference, subject to the following terms.

§ 2 If the Contractor promptly makes payment of all sums due to Claimants, and defends, indemnifies and holds harmless the Owner from claims, demands, liens or suits by any person or entity seeking payment for labor, materials or equipment furnished for use in the performance of the Construction Contract, then the Surety and the Contractor shall have no obligation under this Bond.

§ 3 If there is no Owner Default under the Construction Contract, the Surety's obligation to the Owner under this Bond shall arise after the Owner has promptly notified the Contractor and the Surety (at the address described in Section 13) of claims, demands, liens or suits against the Owner or the Owner's property by any person or entity seeking payment for labor, materials or equipment furnished for use in the performance of the Construction Contract and tendered defense of such claims, demands, liens or suits to the Contractor and the Surety.

§ 4 When the Owner has satisfied the conditions in Section 3, the Surety shall promptly and at the Surety's expense defend, indemnify and hold harmless the Owner against a duly tendered claim, demand, lien or suit.

§ 5 The Surety's obligations to a Claimant under this Bond shall arise after the following:

§ 5.1 Claimants, who do not have a direct contract with the Contractor,

- .1 have furnished a written notice of non-payment to the Contractor, stating with substantial accuracy the amount claimed and the name of the party to whom the materials were, or equipment was, furnished or supplied or for whom the labor was done or performed, within ninety (90) days after having last performed labor or last furnished materials or equipment included in the Claim; and
- .2 have sent a Claim to the Surety (at the address described in Section 13).

§ 5.2 Claimants, who are employed by or have a direct contract with the Contractor, have sent a Claim to the Surety (at the address described in Section 13).

§ 6 If a notice of non-payment required by Section 5.1.1 is given by the Owner to the Contractor, that is sufficient to satisfy a Claimant's obligation to furnish a written notice of non-payment under Section 5.1.1.

§ 7 When a Claimant has satisfied the conditions of Sections 5.1 or 5.2, whichever is applicable, the Surety shall promptly and at the Surety's expense take the following actions:

§ 7.1 Send an answer to the Claimant, with a copy to the Owner, within sixty (60) days after receipt of the Claim, stating the amounts that are undisputed and the basis for challenging any amounts that are disputed; and

§ 7.2 Pay or arrange for payment of any undisputed amounts.

§ 7.3 The Surety's failure to discharge its obligations under Section 7.1 or Section 7.2 shall not be deemed to constitute a waiver of defenses the Surety or Contractor may have or acquire as to a Claim, except as to undisputed amounts for which the Surety and Claimant have reached agreement. If, however, the Surety fails to discharge its obligations under Section 7.1 or Section 7.2, the Surety shall indemnify the Claimant for the reasonable attorney's fees the Claimant incurs thereafter to recover any sums found to be due and owing to the Claimant.

§ 8 The Surety's total obligation shall not exceed the amount of this Bond, plus the amount of reasonable attorney's fees provided under Section 7.3, and the amount of this Bond shall be credited for any payments made in good faith by the Surety.

§ 9 Amounts owed by the Owner to the Contractor under the Construction Contract shall be used for the performance of the Construction Contract and to satisfy claims, if any, under any construction performance bond. By the Contractor furnishing and the Owner accepting this Bond, they agree that all funds earned by the Contractor in the performance of the Construction Contract are dedicated to satisfy obligations of the Contractor and Surety under this Bond, subject to the Owner's priority to use the funds for the completion of the work.

§ 10 The Surety shall not be liable to the Owner, Claimants or others for obligations of the Contractor that are unrelated to the Construction Contract. The Owner shall not be liable for the payment of any costs or expenses of any Claimant under this Bond, and shall have under this Bond no obligation to make payments to, or give notice on behalf of, Claimants or otherwise have any obligations to Claimants under this Bond.

§ 11 The Surety hereby waives notice of any change, including changes of time, to the Construction Contract or to related subcontracts, purchase orders and other obligations.

§ 12 No suit or action shall be commenced by a Claimant under this Bond other than in a court of competent jurisdiction in the state in which the project that is the subject of the Construction Contract is located or after the expiration of one year from the date (1) on which the Claimant sent a Claim to the Surety pursuant to Section 5.1.2 or 5.2, or (2) on which the last labor or service was performed by anyone or the last materials or equipment were furnished by anyone under the Construction Contract, whichever of (1) or (2) first occurs. If the provisions of this Paragraph are void or prohibited by law, the minimum period of limitation available to sureties as a defense in the jurisdiction of the suit shall be applicable.

§ 13 Notice and Claims to the Surety, the Owner or the Contractor shall be mailed or delivered to the address shown on the page on which their signature appears. Actual receipt of notice or Claims, however accomplished, shall be sufficient compliance as of the date received.

§ 14 When this Bond has been furnished to comply with a statutory or other legal requirement in the location where the construction was to be performed, any provision in this Bond conflicting with said statutory or legal requirement shall be deemed deleted herefrom and provisions conforming to such statutory or other legal requirement shall be deemed incorporated herein. When so furnished, the intent is that this Bond shall be construed as a statutory bond and not as a common law bond.

§ 15 Upon request by any person or entity appearing to be a potential beneficiary of this Bond, the Contractor and Owner shall promptly furnish a copy of this Bond or shall permit a copy to be made.

§ 16 Definitions

§ 16.1 Claim. A written statement by the Claimant including at a minimum:

- .1 the name of the Claimant;
- .2 the name of the person for whom the labor was done, or materials or equipment furnished;
- .3 a copy of the agreement or purchase order pursuant to which labor, materials or equipment was furnished for use in the performance of the Construction Contract;
- .4 a brief description of the labor, materials or equipment furnished;
- .5 the date on which the Claimant last performed labor or last furnished materials or equipment for use in the performance of the Construction Contract;
- .6 the total amount earned by the Claimant for labor, materials or equipment furnished as of the date of the Claim;
- .7 the total amount of previous payments received by the Claimant; and
- .8 the total amount due and unpaid to the Claimant for labor, materials or equipment furnished as of the date of the Claim.

§ 16.2 Claimant. An individual or entity having a direct contract with the Contractor or with a subcontractor of the Contractor to furnish labor, materials or equipment for use in the performance of the Construction Contract. The term Claimant also includes any individual or entity that has rightfully asserted a claim under an applicable mechanic's lien or similar statute against the real property upon which the Project is located. The intent of this Bond shall be to include without limitation in the terms "labor, materials or equipment" that part of water, gas, power, light, heat, oil, gasoline, telephone service or rental equipment used in the Construction Contract, architectural and engineering services required for performance of the work of the Contractor and the Contractor's subcontractors, and all other items for which a mechanic's lien may be asserted in the jurisdiction where the labor, materials or equipment were furnished.

§ 16.3 Construction Contract. The agreement between the Owner and Contractor identified on the cover page, including all Contract Documents and all changes made to the agreement and the Contract Documents.

§ 16.4 Owner Default. Failure of the Owner, which has not been remedied or waived, to pay the Contractor as required under the Construction Contract or to perform and complete or comply with the other material terms of the Construction Contract.

§ 16.5 Contract Documents. All the documents that comprise the agreement between the Owner and Contractor.

§ 17 If this Bond is issued for an agreement between a Contractor and subcontractor, the term Contractor in this Bond shall be deemed to be Subcontractor and the term Owner shall be deemed to be Contractor.

§ 18 Modifications to this bond are as follows:

(Space is provided below for additional signatures of added parties, other than those appearing on the cover page.)

CONTRACTOR AS PRINCIPAL

SURETY

Company: _____ *(Corporate Seal)*

Company: _____ *(Corporate Seal)*

Signature: _____
Name and Title: _____
Address _____

Signature: _____
Name and Title: _____
Address _____

CAUTION: You should sign an original AIA Contract Document, on which this text appears in RED. An original assures that changes will not be obscured.



UNITED CASUALTY AND SURETY INSURANCE COMPANY
 US Casualty and Surety Insurance Company
 United Surety Insurance Company

POWER OF ATTORNEY

Agency No. 172158

KNOW ALL MEN BY THESE PRESENTS: That United Casualty and Surety Insurance Company, a corporation of the State of Nebraska, and US Casualty and Surety Insurance Company and United Surety Insurance Company, assumed names of United Casualty and Surety Insurance Company (collectively, the Companies), do by these presents make, constitute and appoint:

Jeffrey L. Booth, David R. Brett, Michael J. Brown, Jason S. Centrella, James E. Feldner, Omar G. Guerra, James A. Mallis, Scott E. Stoltzner, Arthur S. Johnson, Stefan E. Tauger

its true and lawful Attorney(s)-in-Fact, each in their separate capacity if more than one is named above, with full power and authority hereby conferred in its name, place and stead, to execute, acknowledge and deliver any and all bonds, recognizances, undertakings or other instruments or contracts of suretyship to include riders, amendments, and consents of surety, providing the bond penalty does not exceed Three Million & 00/100 Dollars (\$3,000,000.00). This Power of Attorney shall expire without further action on December 31st, 2023.

This Power of Attorney is granted under and by authority of the following resolutions adopted by the Board of Directors of the Companies at a meeting duly called and held on the 1st day of July, 1993:

Resolved that the President, Treasurer, or Secretary be and they are hereby authorized and empowered to appoint Attorneys-in-Fact of the Company, in its name and as its acts to execute and acknowledge for and on its behalf as Surety any and all bonds, recognizances, contracts of indemnity, waivers of citation and all other writings obligatory in the nature thereof, with power to attach thereto the seal of the Company. Any such writings so executed by such Attorneys-in-Fact shall be binding upon the Company as if they had been duly executed and acknowledged by the regularly elected Officers of the Company in their own proper persons.

That the signature of any officer authorized by Resolutions of this Board and the Company seal may be affixed by facsimile to any power of attorney or special power of attorney or certification of either given for the execution of any bond, undertaking, recognizance or other written obligation in the nature thereof; such signature and seal, when so used being hereby adopted by the Company as the original signature of such officer and the original seal of the Company, to be valid and binding upon the Company with the same force and effect as though manually affixed.

IN WITNESS WHEREOF, the Companies have caused this instrument to be signed and their corporate seals to be hereunto affixed, this 5th day of May, 2021.



UNITED CASUALTY AND SURETY INSURANCE COMPANY
 US Casualty and Surety Insurance Company
 United Surety Insurance Company



 Joel R. Chachkes, Treasurer

Corporate Seals

Commonwealth of Massachusetts
 County of Suffolk ss:

On this 5th day of May, 2021, before me, Thomas P. Carrigan, Jr., a notary public, personally appeared Joel R. Chachkes, Treasurer of United Casualty and Surety Insurance Company, US Casualty and Surety Insurance Company and United Surety Insurance Company, who proved to me on the basis of satisfactory evidence to be the person whose name is subscribed to the within instrument and acknowledged to me that he executed the same in his authorized capacity, and that by his signature on the instrument the person(s), or the entity on behalf of which the person(s) acted, executed the instrument.

I certify under PENALTY OF PERJURY under the laws of the Commonwealth of Massachusetts that the foregoing paragraph is true and correct.
 WITNESS my hand and seal.

 _____ (Seal)
 Thomas P. Carrigan, Jr., Notary Public Commission Expires: 10/31/2025

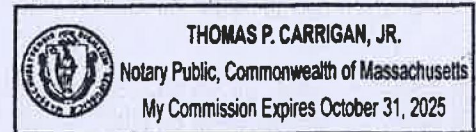

I, Robert F. Thomas, President of United Casualty and Surety Insurance Company, US Casualty and Surety Insurance Company and United Surety Insurance Company do hereby certify that the above and foregoing is a true and correct copy of a Power of Attorney, executed by said Companies, which is still in full force and effect; furthermore, the resolutions of the Board of Directors, set out in the Power of Attorney are in full force and effect.

In Witness Whereof, I have hereunto set my hand and affixed the seals of said Companies at Boston, Massachusetts this 10th day of April, 2023

Corporate Seals



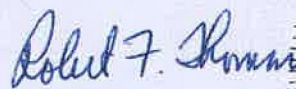

 Robert F. Thomas, President





CERTIFICATE OF LIABILITY INSURANCE

DATE (MM/DD/YYYY)

3/28/2023

THIS CERTIFICATE IS ISSUED AS A MATTER OF INFORMATION ONLY AND CONFERS NO RIGHTS UPON THE CERTIFICATE HOLDER. THIS CERTIFICATE DOES NOT AFFIRMATIVELY OR NEGATIVELY AMEND, EXTEND OR ALTER THE COVERAGE AFFORDED BY THE POLICIES BELOW. THIS CERTIFICATE OF INSURANCE DOES NOT CONSTITUTE A CONTRACT BETWEEN THE ISSUING INSURER(S), AUTHORIZED REPRESENTATIVE OR PRODUCER, AND THE CERTIFICATE HOLDER.

IMPORTANT: If the certificate holder is an ADDITIONAL INSURED, the policy(ies) must have ADDITIONAL INSURED provisions or be endorsed. If SUBROGATION IS WAIVED, subject to the terms and conditions of the policy, certain policies may require an endorsement. A statement on this certificate does not confer rights to the certificate holder in lieu of such endorsement(s).

PRODUCER HUB International Mid-America 9200 Ward Parkway Suite 500 Kansas City MO 64114	CONTACT NAME: Certificate Department PHONE (A/C No, Ext): 816-708-4600 E-MAIL ADDRESS: HUB-KC.Certificates@HUBInternational.com	FAX (A/C, No): 816-203-4425
	INSURER(S) AFFORDING COVERAGE	
INSURED Mid-America Pool Renovation, Inc. 5929 East 154th Terrace Grandview MO 64030	INSURER A : American Casualty Co of Reading PA NAIC # 20427	
	INSURER B : Transportation Insurance Company NAIC # 20494	
	INSURER C : National Fire Insurance Company of Hartford NAIC # 20478	
	INSURER D : The Continental Insurance Company NAIC # 35289	
	INSURER E :	
	INSURER F :	

COVERAGES

CERTIFICATE NUMBER: 1035308611

REVISION NUMBER:

THIS IS TO CERTIFY THAT THE POLICIES OF INSURANCE LISTED BELOW HAVE BEEN ISSUED TO THE INSURED NAMED ABOVE FOR THE POLICY PERIOD INDICATED. NOTWITHSTANDING ANY REQUIREMENT, TERM OR CONDITION OF ANY CONTRACT OR OTHER DOCUMENT WITH RESPECT TO WHICH THIS CERTIFICATE MAY BE ISSUED OR MAY PERTAIN, THE INSURANCE AFFORDED BY THE POLICIES DESCRIBED HEREIN IS SUBJECT TO ALL THE TERMS, EXCLUSIONS AND CONDITIONS OF SUCH POLICIES. LIMITS SHOWN MAY HAVE BEEN REDUCED BY PAID CLAIMS.

INSR LTR	TYPE OF INSURANCE	ADDL INSD	SUBR WVD	POLICY NUMBER	POLICY EFF (MM/DD/YYYY)	POLICY EXP (MM/DD/YYYY)	LIMITS
B	<input checked="" type="checkbox"/> COMMERCIAL GENERAL LIABILITY <input type="checkbox"/> CLAIMS-MADE <input checked="" type="checkbox"/> OCCUR GEN'L AGGREGATE LIMIT APPLIES PER: <input type="checkbox"/> POLICY <input checked="" type="checkbox"/> PRO-JECT <input type="checkbox"/> LOC OTHER:	Y		4020096140	10/1/2022	10/1/2023	EACH OCCURRENCE \$ 1,000,000 DAMAGE TO RENTED PREMISES (Ea occurrence) \$ 100,000 MED EXP (Any one person) \$ 15,000 PERSONAL & ADV INJURY \$ 1,000,000 GENERAL AGGREGATE \$ 2,000,000 PRODUCTS - COMP/OP AGG \$ 2,000,000 \$
A	AUTOMOBILE LIABILITY <input checked="" type="checkbox"/> ANY AUTO <input type="checkbox"/> OWNED AUTOS ONLY <input type="checkbox"/> SCHEDULED AUTOS <input checked="" type="checkbox"/> HIRED AUTOS ONLY <input checked="" type="checkbox"/> NON-OWNED AUTOS ONLY	Y		BUA4020096137	10/1/2022	10/1/2023	COMBINED SINGLE LIMIT (Ea accident) \$ 1,000,000 BODILY INJURY (Per person) \$ BODILY INJURY (Per accident) \$ PROPERTY DAMAGE (Per accident) \$ \$
D	<input checked="" type="checkbox"/> UMBRELLA LIAB <input checked="" type="checkbox"/> OCCUR <input type="checkbox"/> EXCESS LIAB <input type="checkbox"/> CLAIMS-MADE <input type="checkbox"/> DED <input checked="" type="checkbox"/> RETENTION \$ 10,000	Y		4020096123	10/1/2022	10/1/2023	EACH OCCURRENCE \$ 4,000,000 AGGREGATE \$ 4,000,000 \$
C	WORKERS COMPENSATION AND EMPLOYERS' LIABILITY ANY PROPRIETOR/PARTNER/EXECUTIVE OFFICER/MEMBER EXCLUDED? (Mandatory in NH) If yes, describe under DESCRIPTION OF OPERATIONS below	Y/N N	N/A	WC650490916	10/1/2022	10/1/2023	<input checked="" type="checkbox"/> PER STATUTE <input type="checkbox"/> OTH-ER E.L. EACH ACCIDENT \$ 1,000,000 E.L. DISEASE - EA EMPLOYEE \$ 1,000,000 E.L. DISEASE - POLICY LIMIT \$ 1,000,000

DESCRIPTION OF OPERATIONS / LOCATIONS / VEHICLES (ACORD 101, Additional Remarks Schedule, may be attached if more space is required)

Re: Lincoln Park-Moyer Pool Re-Plaster & Repair IFB-5177-23-KH; The City of Grand Junction, Mesa County and all of the city's and county's officers and employees are Additional Insured as respects the General, Auto and Umbrella Liability policies.

CERTIFICATE HOLDER**CANCELLATION**

City of Grand Junction
 Department of Public Works
 250 North Fifth Street
 Grand Junction CO 81501

SHOULD ANY OF THE ABOVE DESCRIBED POLICIES BE CANCELLED BEFORE THE EXPIRATION DATE THEREOF, NOTICE WILL BE DELIVERED IN ACCORDANCE WITH THE POLICY PROVISIONS.

AUTHORIZED REPRESENTATIVE

© 1988-2015 ACORD CORPORATION. All rights reserved.