

<b>CITY OF GRAND JUNCTION DEPARTMENT OF PUBLIC WORKS</b>  <b>MEMORANDUM OF AGREEMENT</b>	<b>Project No.: 207-F1903</b>
	<b>Description: F ½ Road Parkway Improvement Project</b>
	<b>Owner(s): Grand Junction Holdings I, LLC</b>
	<b>Parcels: RW-5, MPE-5, TCE-5</b>

This Memorandum of Agreement (“Agreement”) is made and entered into this \_\_\_\_\_ day of \_\_\_\_\_, 2023, by and between **Grand Junction Holdings I, LLC**, hereinafter referred to as “the Owner”, and the City of Grand Junction, a Colorado home rule municipality, hereinafter referred to as “the City”.

RECITALS:

- A. The City is proceeding with implementation of the F ½ Road Parkway Improvement Project (“Project”). The Project will create a fully developed street section from 24 Road on the west to 25 Road on the east. The project will also add street improvements to 25 Road from Patterson Road on the south to Waite Avenue on the north. Improvements include additional travel lanes, auxiliary lanes, facilities to accommodate pedestrian and bicycle mobility, storm drainage facilities, street lighting, landscaped medians and parkways, and a new roundabout at the intersection of F ½ Road Parkway and 24 ½ Road (“Project Improvements”). The City Council of the City has determined that the Project is necessary for the health, safety and welfare of the inhabitants of the City of Grand Junction. All costs associated with installation of the Project Improvements will be borne by the City.
- B. The Owner owns certain real property within the limits of the Project located at 647 24 ½ Road in the City of Grand Junction, County of Mesa, State of Colorado, as identified by Mesa County Assessor Parcel Number 2945-043-00-186, hereinafter referred to as “the Owner’s Property”.
- C. The installation, operation, maintenance, repair and replacement of the Project Improvements requires the acquisition of the following described real property interests from the Owner:

**Parcel No. RW-5:** A parcel of land in fee simple to be used as public right of way for F ½ Road, containing a total area of 124,807 square feet (2.87 acres), more or less, as more particularly described in the accompanying legal description labeled Exhibit “A” and depicted on the accompanying graphic illustration labeled Exhibit “B”; and also

**Parcel No. MPE-5:** A Multi-Purpose Easement for the installation, operation, maintenance and repair of public utilities, traffic control facilities, street lighting, landscaping, trees, grade structures, public sidewalks and trails, containing a total area of 23,312 square feet (0.54 acres), more or less, as more particularly described in the accompanying legal description labeled Exhibit “C” and depicted on the accompanying graphic illustration labeled Exhibit “D”; and also

**Parcel No. TCE-5:** A Temporary Construction Easement to facilitate prudent, proper, safe and efficient installation of the Project Improvements, containing a total area of 8,803 square feet (0.20 acres), more or less, as more particularly depicted on the accompanying graphic illustration labeled Exhibit “E”. The City’s required duration of use for Parcel No. TCE-5 is 24 months.

The above referenced real property interests may be referred to collectively hereafter as the “Acquired Property”.

- D. The City has obtained and reviewed a waiver valuation to estimate the fair market value and just compensation to be offered for the Acquired Property. In consideration of the foregoing, the City and the Owner agree to the following sum of money as just compensation for the Acquired Property and any improvements, damages or costs to cure itemized below:

Parcel No. RW-5:	124,807 sq.ft. @ \$5.181859/sq.ft.	= \$646,732
Parcel No. MPE-5:	23,312 sq.ft @ \$5.181859/sq.ft. (40%)	=\$48,320
Parcel No. TCE-5:	8,803 sq.ft @ \$5.181859/sq.ft. (7%) 24 months	=\$6,386
	<b>Total Land &amp; Easement Value</b>	<b>= \$701,438</b>
Improvements: Wire Fencing		=\$817
	<b>Total Land, Easement Value &amp; Improvements</b>	<b>= \$702,255</b>
	<b>Total Consideration</b>	<b>= \$702,300 (rounded)</b>

NOW, THEREFORE, based on the recitals above and in consideration of their mutual promises and other valuable consideration, the receipt and adequacy of which are acknowledged, the parties hereto agree as follows:

1. The Owner hereby accepts the Total Consideration stated above from the City as just compensation, and the City hereby agrees to pay the Total Consideration to the Owner subject to the promises, terms, covenants and conditions of this Agreement.
2. Subject to the City's typical payment processing period, the Total Consideration shall be remitted, at the City's sole discretion, to the Owner by either (1) the City directly in the form of a City check, or (2) a title company selected by the City, to which the City has deposited the Total Consideration pending upon the execution and delivery by the Owner to the City of:
  - a. One (1) fully executed original of this Memorandum of Agreement.
  - b. One (1) good and sufficient Special Warranty Deed for Parcel No. RW-5
  - c. One (1) good and sufficient Multi-Purpose Easement Agreement for Parcel No. MPE-5
  - d. One (1) good and sufficient Temporary Construction Easement Agreement for Parcel No. TCE-5
  - e. One (1) completed and executed Federal Form W-9.
  - f. Satisfaction(s) or release(s) of any and all outstanding items referenced in Paragraph 3 below.
3. The Total Consideration shall fully compensate the Owner for the Owner's interests in and to the Acquired Property, either present or future, and the interests of all lienors and lessees of the Owner and any and all interests, legal or equitable, which are or may be outstanding, including, but not limited to: ad valorem property taxes due for prior years; current year ad valorem property taxes prorated to the date of closing (applicable to any fee simple parcel included in the Acquired Property), and satisfaction, subordination or release of all liens, judgments and financial encumbrances to deliver financially unencumbered title to the City. The Owner agrees to sell, convey and discharge all such interests in and to the Acquired Property by executing in writing any and all necessary deeds, documents and/or conveyances, including but not limited to, requests for releases, whether full or partial as applicable, or subordinations of deeds of trust.
4. The City shall deposit the consideration set forth above into an escrow account for the benefit of the Owner with the City's selected title company. Transfer of title to the Acquired Property shall occur upon performance of any and all terms under this Agreement, and release of the Total Consideration due to the Owner.
5. The City agrees that, upon the request of Owner or successor or assign of Owner, the City's Contractor for the project shall add Owner (or such successor or assign) as an additional insured on the Contractor's insurance policy or policies as may be required for the Project that cover or apply to MPE-5 and/or TCE-5.
6. This Memorandum of Agreement embodies all agreements between the parties hereto and no other promises, terms, conditions or obligations, oral or written, have been made which might serve to modify, add to or change the terms and conditions of this Agreement.
7. This Memorandum of Agreement shall be deemed a contract extending to and binding upon the parties hereto and upon their respective heirs, successors and assigns.
8. The City will be entitled to specific performance of this Agreement upon tender of the agreed consideration.
9. This Agreement is a legal instrument. The City recommends the Owner seek the advice of the Owner's own legal and/or tax counsel before signing this Agreement.

Dated the day and year first above written.

**Owner:**  
**Grand Junction Holdings I, LLC**

  
By: Jill Preston  
Title: Vice President

**The City of Grand Junction,**  
**a Colorado home rule municipality:**

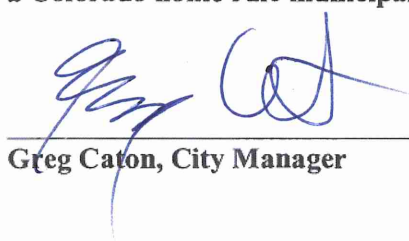
  
Greg Caton, City Manager

**Contract Purchaser Consent:**

By virtue of that certain Contract to Buy and Sell Real Estate dated November 6, 2021, as amended on February 24, 2022, and as further amended on December 6, 2022, the undersigned "Buyer" in said Contract hereby waives any and all claims against the City to compensation and/or damages by or from City arising from this agreement, and hereby releases the City and City's officers, employees, agents and contractors from any and all claims for compensation or damages arising out of or in connection with City's taking, use and occupancy of said Parcel RW-5, MPE-5 and TCE-5, and any and all interests therein. The said Buyer hereby covenants and agrees to not interfere with or obstruct the City's use and occupancy of Parcels RW-5, MPE-5 and TCE-5, when said Parcel is required by the City's contractor to perform necessary work within said Parcels. Nothing in this Consent shall be deemed to waive any claim against Seller, per said Contract, also known as Owner per this Agreement, or to otherwise release Seller/Owner from any of Seller's/Owner's obligations under the above-referenced Contract to Buy and Sell Real Estate.

Signed this 6th day of April, 2023 by

Terry M Ruckman, as Member

on behalf of Ruckman Holdings, LLC

20618129\_v9



# EXHIBIT A

## LEGAL DESCRIPTION

2945-043-00-186

RIGHT-OF-WAY PARCEL NO. RW-5

A parcel of land being a portion of the land as described in Reception Number 2550281 lying in the NE1/4 SW1/4 of Section 4, Township 1 South, Range 1 West of the Ute Meridian, City of Grand Junction, County of Mesa, State of Colorado and being more particularly described as follows:

Beginning at the Center West 1/16 Corner of said Section 4, and assuming the North line of said NE1/4 SW1/4 bears N89°55'28"E with all other bearings contained herein being relative thereto;  
 thence from said point of beginning, N89°55'28"E along said North line, a distance of 1,288.92 feet to a point on the West Right-of-Way line of 24 1/2 Road as described in Reception Number 843255, said point being 30.00 feet west of the Center 1/4 Corner of said Section 4; thence S00°01'45"W along said West Right-of-Way line, a distance of 555.64 feet to the SE Corner of the parcel of land as described in Reception Number 2550281; thence S89°53'37"W along the boundary of said parcel of land, a distance of 10.00 feet; thence N00°01'45"E, a distance of 230.58 feet; thence Northwesterly along the arc of a 592.00 foot radius curve concave Northwesterly, a distance of 56.07 feet with a central angle of 5°25'35" whose chord bears N02°41'15"W, a distance of 56.05 feet; thence Northwesterly along the arc of a 283.85 foot radius curve concave northwesterly, a distance of 21.04 feet thru a central angle of 4°14'47" whose chord bears N07°40'32"W, a distance of 21.03 feet; thence N24°42'52"W, a distance of 139.88 feet; thence Northwesterly along the arc of a 57.00 foot radius curve concave Northwesterly, a distance of 58.26 feet thru a central angle of 58°33'57" whose chord bears N53°59'50"W, a distance of 55.76 feet; thence N83°30'09"W, a distance of 1.89 feet; thence S89°55'08"W, a distance of 1025.44 feet; thence Northwesterly along the arc of a 880.00 foot radius curve concave Northwesterly, a distance of 143.02 feet thru a central angle of 9°18'43" whose chord bears N85°25'30"W, a distance of 142.86 feet, to a point on the West line of said NE1/4 SW1/4; thence N00°00'02"E along said West line, a distance of 76.55 feet to the Point of Beginning.

Said Parcel of land CONTAINING **124,807** Square Feet or **2.87** Acres, more or less, as described.

Authorized by: Jodie L Grein, CO PLS #38075  
 Rolland Consulting Engineers  
 405 Ridges Blvd. Suite A  
 Grand Junction, CO 81507



The sketch & description shown hereon have been derived from subdivision plats & deed descriptions as they appear in the office of the Mesa County Clerk & Recorder & monuments as shown. This sketch does not constitute a legal boundary survey, & is not intended to be used as a means for establishing or verifying property boundary lines.

DRAWN BY: NCW  
 DATE: 05-2022  
 REVIEWED BY: JLG  
 APPROVED BY: BH  
 SCALE: \_\_\_\_\_

Portion of 2945-043-00-186  
 Located in part of the NE1/4 SW1/4  
 Section 4, T.1S, R.1W  
 Ute Meridian, City of Grand Junction  
 Mesa County, Colorado



PUBLIC WORKS  
 ENGINEERING DIVISION  
 PROJECT NO. 207-F210306

ABBREVIATIONS		
P.O.C.	Point of Commencement	Rec. Reception
P.O.B.	Point of Beginning	No. Number
R.O.W.	Right-of-Way	RW Right-of-Way
R.	Section	MPE Multi-Purpose Easement
S.	Township	TCE Temporary Construction Easement
R.	Range	U.M. Ute Meridian
~	Approximately	

# EXHIBIT B

## 2945-043-00-186 RIGHT-OF-WAY PARCEL NO. RW-5

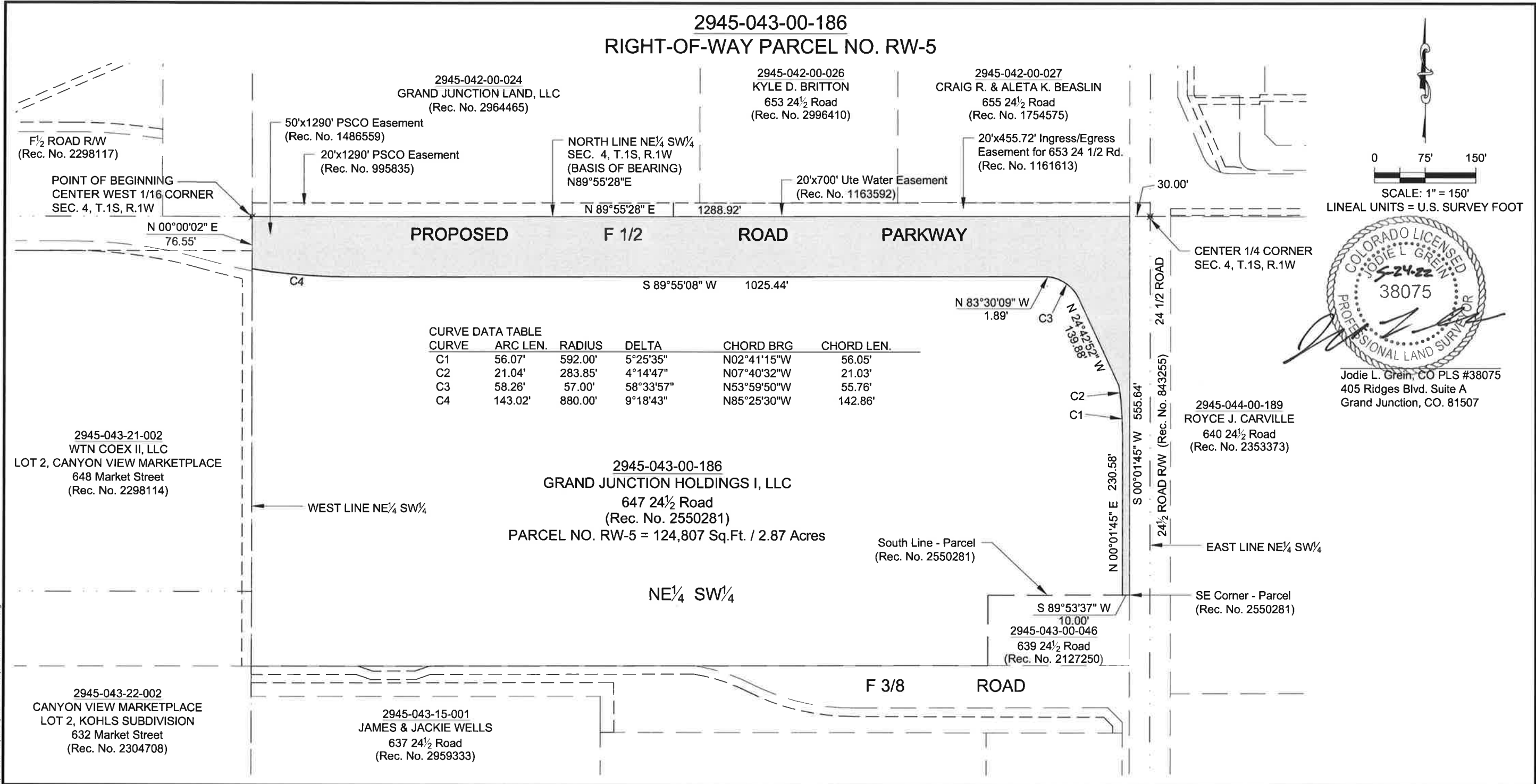

CURVE DATA TABLE

CURVE	ARC LEN.	RADIUS	DELTA	CHORD BRG	CHORD LEN.
C1	56.07'	592.00'	5°25'35"	N02°41'15"W	56.05'
C2	21.04'	283.85'	4°14'47"	N07°40'32"W	21.03'
C3	58.26'	57.00'	58°33'57"	N53°59'50"W	55.76'
C4	143.02'	880.00'	9°18'43"	N85°25'30"W	142.86'

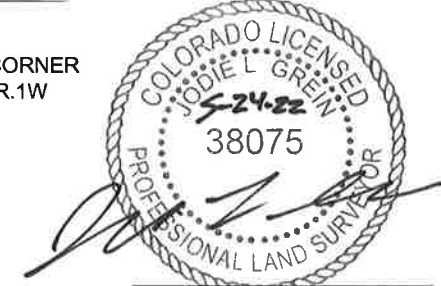
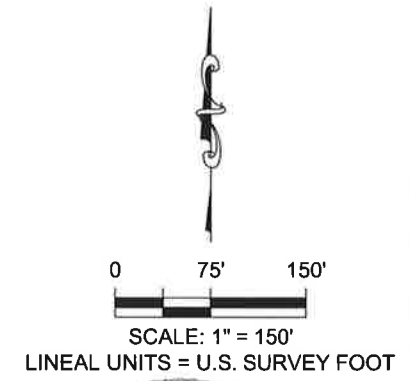

Jodie L. Grein, CO PLS #38075  
405 Ridges Blvd. Suite A  
Grand Junction, CO. 81507

C:\Projects\2022\F.5 Rd City GA\Parcel 5\CAD\Parcel 5\_Acquisition Docs.dwg - PLOTTED 2022-05-24

**ABBREVIATIONS**

P.O.C.	Point of Commencement	Rec.	Reception
P.O.B.	Point of Beginning	No.	Number
R.O.W.	Right-of-Way	RW	Right-of-Way
R.	Section	MPE	Multi-Purpose Easement
S.	Township	TCE	Temporary Construction Easement
R.	Range	U.M.	Ute Meridian
~	Approximately		

The sketch & description shown hereon have been derived from subdivision plats & deed descriptions as they appear in the office of the Mesa County Clerk & Recorder & monuments as shown. This sketch does not constitute a legal boundary survey, & is not intended to be used as a means for establishing or verifying property boundary lines.

DRAWN BY: NCW  
DATE: 05-2022  
REVIEWED BY: JLG  
APPROVED BY: BH  
SCALE: 1" = 150'

Portion of 2945-043-00-186  
Located in part of the NE 1/4 SW 1/4  
Section 4, T.1S, R.1W  
Ute Meridian, City of Grand Junction  
Mesa County, Colorado

**CITY OF Grand Junction COLORADO**

**PUBLIC WORKS ENGINEERING DIVISION**

PROJECT NO. 207-F210306

# EXHIBIT C

## LEGAL DESCRIPTION

2945-043-00-186

MULTI-PURPOSE EASEMENT PARCEL NO. MPE-5

A fourteen foot (14') wide parcel of land being a portion of the land as described in Reception Number 2550281 lying in the NE1/4 SW1/4 of Section 4, Township 1 South, Range 1 West of the Ute Meridian, City of Grand Junction, County of Mesa, State of Colorado and being more particularly described as follows:

Commencing at the Center West 1/16 Corner of said Section 4, and assuming the North line of said NE1/4 SW1/4 bears N89°55'28"E with all other bearings contained herein being relative thereto; thence from said point of commencement, S00°00'02"W along said West line, a distance of 76.55 feet to the SW corner of Right-of-Way Parcel No. RW-5 conveyed to the City of Grand Junction and the Point of Beginning;

thence along the boundary of said RW-5 for the following twenty (8) courses: Southeasterly along the arc of a 880.00 foot radius curve concave Northerly, a distance of 143.02 feet thru a central of 09°18'43" whose chord bears S85°25'30"E, a distance of 142.86 feet; N89°55'08"E, a distance of 1025.44 feet; S83°30'09"E, a distance of 1.89 feet; Southeasterly along the arc of a 57.00 foot radius non-tangent curve concave Southerly, a distance of 58.26 feet thru a central angle of 58°33'57" whose chord bears S53°59'50"E, a distance of 55.76 feet; S24°42'52"E, a distance of 139.88 feet; continuing Southeasterly along the arc of a 283.85 foot radius curve concave Southerly, a distance of 21.04 feet thru a central of 4°14'47" whose chord bears S07°40'32"E, a distance of 21.03 feet; Southeasterly along the arc of a 592.00 foot radius curve concave Southwesterly, a distance of 56.07 feet thru a central angle of 5°25'33" whose chord bears S02°41'15"E, a distance of 56.05 feet; S00°01'45"W, a distance of 230.58 feet, to a point on the South line of land as described in Reception Number 2550281; thence S89°53'37"W along the boundary of said parcel of land, a distance of 14.00 feet; thence N00°01'45"E, a distance of 230.62 feet; thence Northwesterly along the arc of a 577.99 foot radius curve concave Northwesterly, a distance of 54.72 feet with a central of angle of 5°25'29" whose chord bears N02°41'11"W, a distance of 54.70 feet; thence Northwesterly along the arc of a 269.85 foot radius curve concave northwesterly, a distance of 18.17 feet thru a central angle of 3°51'30" whose chord bears N07°29'07"W, a distance of 18.17 feet; thence N24°42'52"W, a distance of 138.02 feet; thence Northwesterly along the arc of a 43.00 foot radius curve concave Northwesterly, a distance of 43.93 feet thru a central angle of 58°31'56" whose chord bears N53°58'50"W, a distance of 42.04 feet; N83°30'09"W, a distance of 1.06 feet; S89°55'08"W, a distance of 1024.63 feet; thence Northwesterly along the arc of a 894.00 foot radius curve concave Northwesterly, a distance of 143.02 feet thru a central angle of 9°09'58" whose chord bears N85°29'53"W, a distance of 142.87 feet, to a point on the West line of said NE1/4 SW1/4; thence N00°00'02"E along said West line, a distance of 14.18 feet to the Point of Beginning.

Said Parcel of land CONTAINING **23,312** Square Feet or **0.54** Acres, more or less, as described.

Authored by: Jodie L Grein, CO PLS #38075  
405 Ridges Blvd. Suite A  
Grand Junction, CO 81507



C:\Projects\2426 F.S Rd City of Grand Junction\Parcel 5 Acquisition Docs.dwg - PLOTTED 2022-05-24

ABBREVIATIONS		
P.O.C.	Point of Commencement	Rec. Reception
P.O.B.	Point of Beginning	No. Number
R.O.W.	Right-of-Way	RW Right-of-Way
R.	Section	MPE Multi-Purpose Easement
S.	Township	TCE Temporary Construction Easement
R.	Range	U.M. Ute Meridian
~	Approximately	

The sketch & description shown hereon have been derived from subdivision plats & deed descriptions as they appear in the office of the Mesa County Clerk & Recorder & monuments as shown. This sketch does not constitute a legal boundary survey, & is not intended to be used as a means for establishing or verifying property boundary lines.

DRAWN BY: NCW  
DATE: 05-2022  
REVIEWED BY: JLG  
APPROVED BY: BH  
SCALE: \_\_\_\_\_

Portion of 2945-043-00-186  
Located in part of the NE<sup>1</sup>/<sub>4</sub> SW<sup>1</sup>/<sub>4</sub>  
Section 4, T.1S, R.1W  
Ute Meridian, City of Grand Junction  
Mesa County, Colorado

CITY OF  
**Grand Junction**  
COLORADO

---

PUBLIC WORKS  
ENGINEERING DIVISION  
PROJECT NO. 207-F210306

# EXHIBIT D

## 2945-043-00-186 MULTI-PURPOSE EASEMENT PARCEL NO. MPE-5

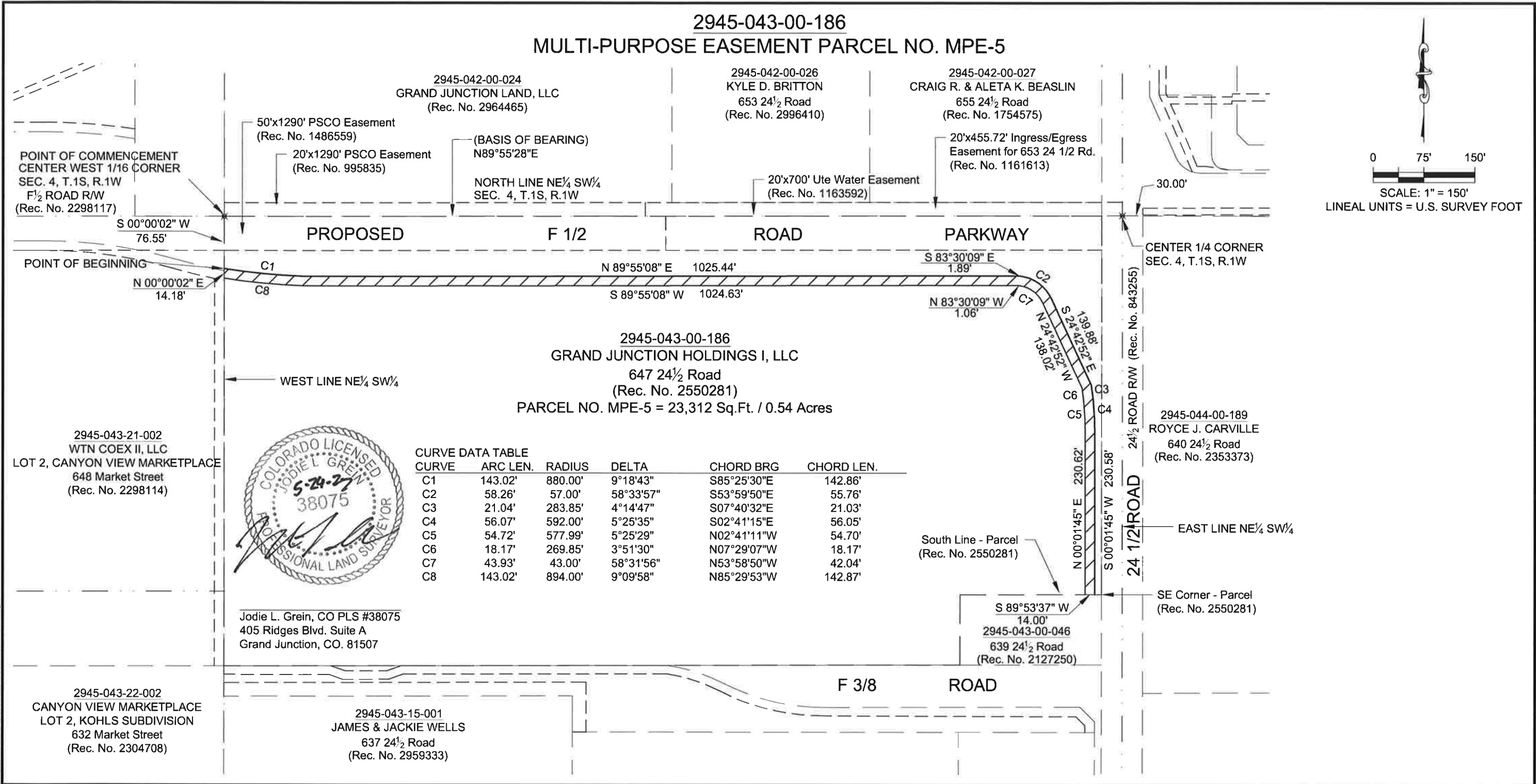

CURVE DATA TABLE					
CURVE	ARC LEN.	RADIUS	DELTA	CHORD BRG	CHORD LEN.
C1	143.02'	880.00'	9°18'43"	S85°25'30"E	142.86'
C2	58.26'	57.00'	58°33'57"	S53°59'50"E	55.76'
C3	21.04'	283.85'	4°14'47"	S07°40'32"E	21.03'
C4	56.07'	592.00'	5°25'35"	S02°41'15"E	56.05'
C5	54.72'	577.99'	5°25'29"	N02°41'11"W	54.70'
C6	18.17'	269.85'	3°51'30"	N07°29'07"W	18.17'
C7	43.93'	43.00'	58°31'56"	N53°58'50"W	42.04'
C8	143.02'	894.00'	9°09'58"	N85°29'53"W	142.87'



Jodie L. Grein, CO PLS #38075  
405 Ridges Blvd. Suite A  
Grand Junction, CO. 81507

ABBREVIATIONS		
P.O.C.	Point of Commencement	Rec. Reception
P.O.B.	Point of Beginning	No. Number
R.O.W.	Right-of-Way	RW Right-of-Way
R.	Section	MPE Multi-Purpose Easement
S.	Township	TCE Temporary Construction Easement
R.	Range	U.M. Ute Meridian
~	Approximately	

The sketch & description shown hereon have been derived from subdivision plats & deed descriptions as they appear in the office of the Mesa County Clerk & Recorder & monuments as shown. This sketch does not constitute a legal boundary survey, & is not intended to be used as a means for establishing or verifying property boundary lines.

DRAWN BY:	NCW
DATE:	05-2022
REVIEWED BY:	JLG
APPROVED BY:	BH
SCALE:	1" = 150'

Portion of 2945-043-00-186  
Located in part of the NE 1/4 SW 1/4  
Section 4, T.1S, R.1W  
Ute Meridian, City of Grand Junction  
Mesa County, Colorado

**CITY OF Grand Junction COLORADO**

**PUBLIC WORKS ENGINEERING DIVISION**

PROJECT NO. 207-F210306

C:\Projects\202426 F.S Rd City G:\Parcel 5\CAD\Parcel 5 Acquisition Docs.dwg - PLOTTED 2022-05-24

# EXHIBIT E

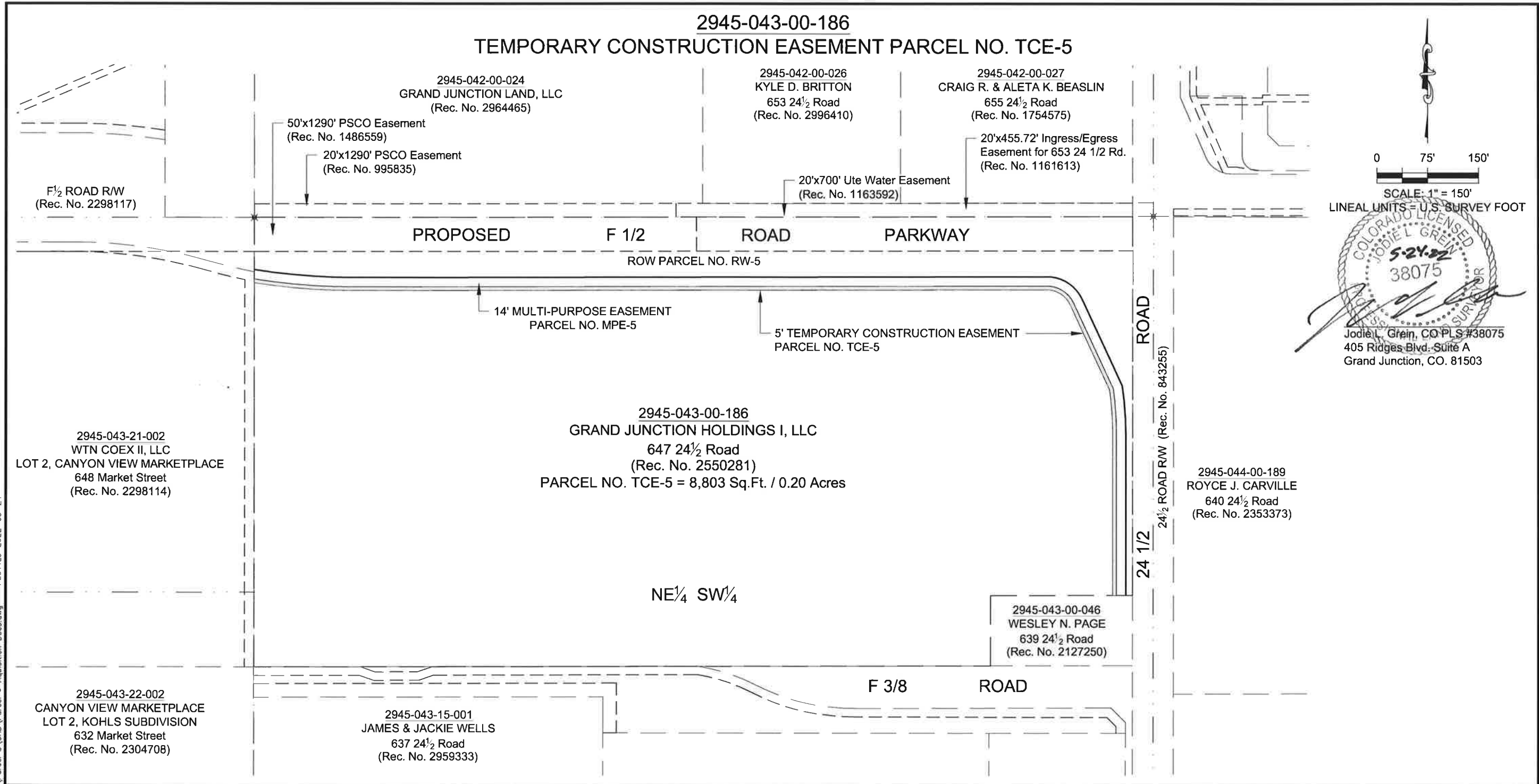

SCALE: 1" = 150'  
LINEAL UNITS = U.S. SURVEY FOOT

0 75' 150'

COLORADO LICENSED  
JODIE L. GREIN  
5-24-22  
38075  
SURVEYOR

Jodie L. Grein, CO PLS #38075  
405 Ridges Blvd. Suite A  
Grand Junction, CO. 81503

C:\Projects\02426 F.S. Rd City GA\Parcel 5\CAD\Parcel 5 Aquisition Decs.dwg - PLOTTED 2022-05-24

ABBREVIATIONS		
P.O.C.	Point of Commencement	Rec. Reception
P.O.B.	Point of Beginning	No. Number
R.O.W.	Right-of-Way	RW Right-of-Way
R.	Section	MPE Multi-Purpose Easement
S.	Township	TCE Temporary Construction Easement
R.	Range	U.M. Ute Meridian
~	Approximately	

The sketch & description shown hereon have been derived from subdivision plats & deed descriptions as they appear in the office of the Mesa County Clerk & Recorder & monuments as shown. This sketch does not constitute a legal boundary survey, & is not intended to be used as a means for establishing or verifying property boundary lines.

DRAWN BY:	NCW
DATE:	01-2022
REVIEWED BY:	JLG
APPROVED BY:	BH
SCALE:	1" = 150'

Portion of 2945-043-00-186  
Located in part of the NE 1/4 SW 1/4  
Section 4, T.1S, R.1W  
Ute Meridian, City of Grand Junction  
Mesa County, Colorado

**CITY OF**  
**Grand Junction**  
COLORADO

**PUBLIC WORKS**  
**ENGINEERING DIVISION**  
PROJECT NO. 207-F210306