



## CHANGE ORDER Number 2

Date: September 5, 2023  
 To: Merritt & Associates, G.C., Inc.  
 From: City of Grand Junction, General Services Department  
 Project: **Safety Bollard Purchase and Installation Project, IFB-5244-23-KF**  
 P.O.: **2023-00000296**

It is agreed to modify the Contract for the Project as follows:

Change Order #2 with Merritt & Associates, G.C., Inc. to include the purchase and installation of two (2) additional removeable eight (8) inch stainless-steel bollards with embedment sleeves at the Contracted Unit Price of \$8,896.26. And the removal and replacement of one four (4) foot by five (5) foot concrete stone, split cost between Contractor and City \$864.00.

Summary of Contract price adjustments:

Original Contract Amount	\$147,253.20
Approved Change Orders	\$ 3,925.00
This Change Order	<u>\$ 18,656.52</u>
<b>Revise Contract Amount</b>	<b>\$169,834.72</b>

Summary of Contract time adjustments:

Original Contract Time	120.	Cal. Days
Approved Change Orders	0.	
This Change Order	<u>42.</u>	
<b>Revise Contract Time</b>	<b>162.</b>	<b>Cal. Days</b>
Pre-Construction Start Date:	June 15, 2023	
Construction Completion Date:	November 3, 2023	

This modification constitutes compensation in full for all costs and mark-ups directly and/or indirectly attributable to the changes ordered herein, for all delays, impacts and disruptions related thereto and for performance of the changes within the Contract.

Owner: **City of Grand Junction**

Created by: DocuSigned by: Duane Hoff Jr. 9/6/2023  
5F788E7D50F14FC  
 Duane Hoff Jr., Contract Administrator

Approved by: DocuSigned by: Kyle Coltrinari 9/6/2023  
5B9E0D71D28916  
 Kyle Coltrinari, General Service Manager

Approved by: DocuSigned by: Jay Valentine 9/6/2023  
05B403052E0A957  
 Jay Valentine, General Services Director

Contractor: **Merritt & Associates, G.C., Inc.**

Approved by: DocuSigned by: Brian Holton 9/6/2023  
239E89FE10DE414  
 Brian Holton, VP



# Merritt & Associates G.C., Inc.

September 5, 2023

Merritt & Associates G.C., Inc.  
2108 Highway 6 & 50  
Grand Junction, CO 81505  
(970)241-5164 (970)241-8595

Prepared For: City of GJ  
Project: City Bollard Project  
Address: Police Station  
Attn: Kyle Coltriani

### Change Order: #2

Merritt & Associates G.C., Inc. hereby proposes the following change order: Provide labor, materials, and equipment for construction of changes to scope of work.

1. Provide and install two (2) new 8" ASTM crash tested, stainless steel, polished Internal Locking removable bollards at the Police Station. **\$17,792.52**
2. Split the cost of removing and replacing one 4' x 5' piece of concrete. **\$864.00**

**Change Order #2: \$18,656.52**

**Acceptance of Proposal: The above prices, specifications and conditions are satisfactory and are hereby accepted. Merritt & Associates G C INC employees are fully covered by Workers Compensation Insurance and required Contractor's licensing and Liability Insurance coverage.**

**This proposal may be withdrawn if not accepted within 14 days.**

DocuSigned by:  
*Brian Holton*  
23B688FE1DCE114  
\_\_\_\_\_  
**Merritt & Associates, G.C., Inc.**

Date 9/6/2023

DocuSigned by:  
*Duane Hoff Jr.*  
9F788E7D90F14BC  
\_\_\_\_\_  
**Client Signature/Title**  
**Duane Hoff Jr.**

**Contract Administrator**  
**9/6/2023**



## NOTICE TO PROCEED

Date: June 15, 2023  
Contractor: Merritt & Associates CG Inc  
Project: Safety Bollard Purchase and Installation Project IFB-5244-23-KF

In accordance with the contract dated June 1, 2023, the Contractor is hereby notified to begin work on the Project on or before immediately. Total project completion duration has been revised from 75 days to 120 days, to accommodate product lead time of five (5) to seven (7) weeks for delivery and installation.

The date of final completion as determined is October 6, 2023.

### CITY OF GRAND JUNCTION, COLORADO

A handwritten signature in blue ink, appearing to read "K. Franklin", is written over a horizontal line.

Kathleen Franklin, Senior Buyer

Receipt of this Notice to Proceed is hereby acknowledged:

Contractor: Merritt & Associates GC Inc.

By: DocuSigned by:  
*Brian Holton*  
23B689FETD0E414...

Print Name: Brian Holton

Title: VP

Date: 6/17/2023



# CHANGE ORDER

## Number 1

Date: July 28, 2023  
To: Merritt & Associates, G.C., Inc.  
From: City of Grand Junction, General Services Department  
Project: **Safety Bollard Purchase and Installation Project, IFB-5244-23-KF**  
P.O.: **2023-00000296**

It is agreed to modify the Contract for the Project as follows:  
Change Order #1 increases Merritt & Associates, G.C., Inc. scope to include the removal and replacement of existing colored concrete ADA access ramp, approximately nine (9) feet by six (6) feet to allow for better placement of the safety bollards.

Summary of Contract price adjustments:

Original Contract Amount	\$147,253.20
Approved Change Orders to Date	\$ 0.00
This Change Order	<u>\$ 3,925.00</u>
<b>Revise Contract Amount</b>	<b>\$151,178.20</b>

This modification constitutes compensation in full for all costs and mark-ups directly and/or indirectly attributable to the changes ordered herein, for all delays, impacts and disruptions related thereto and for performance of the changes within the Contract Time.

Owner: City of Grand Junction

Created by: DocuSigned by: Duane Hoff Jr. 7/28/2023  
3F789E7D59F145C  
Duane Hoff Jr., Contract Administrator

Approved by: DocuSigned by: Kyle Coltrinari 8/1/2023  
3B9B6D71D248416  
Kyle Coltrinari, General Service Manager

Approved by: DocuSigned by: Jay Valentine 8/1/2023  
D9BA3BDD3E1D0457  
Jay Valentine, General Services Director

Contractor: Merritt & Associates, G.C., Inc.

Approved by: DocuSigned by: Brian Holton 7/28/2023  
23B009FE1D0E414  
Brian Holton, VP



# Merritt & Associates G.C., Inc.

July 25, 2023

Merritt & Associates G.C., Inc.  
2108 Highway 6 & 50  
Grand Junction, CO 81505  
(970)241-5164 (970)241-8595

Prepared For: City of GJ  
Project: City Bollard Project  
Address: Police Station  
Attn: Kyle Coltriani

### Change Order: #1

Merritt & Associates G.C., Inc. hereby proposes the following change order: Provide labor, materials, and equipment for construction of changes to scope of work.

1. Remove and replace existing colored concrete ADA access ramp approx. 9' x 6' to allow for better location of bollards.

**Change Order#1: \$3,925.00**

The following items are excluded from the bid total and if required will be charged at the rate of cost plus 10% and a \$85.00 per hour plus 10% acquisition fee.

1. ~~Permits and/or Government Fees, if required~~
2. ~~Engineering of any kind~~
3. ~~Architectural Drawings~~
4. ~~Drawings of any kind~~
5. ~~Testing~~
6. ~~Any other item not mentioned in scope of work.~~

~~Terms: payment is due upon receipt of invoice. All past due accounts shall bear an interest rate of 3.0 percent per month, compounded (36% annual rate) on all unpaid balances. Customers will be responsible to pay all service charges from suppliers in the event of unpaid balance of materials. Customer is to pay all reasonable costs of collection including but not limited to attorney's fees and travel in the pursuit of unpaid amounts. All litigations will be conducted in MESA COUNTY. The agreements on this contract SUPERSEDE all other terms and /or documents. Terms of this proposal and acceptance will be binding and accepted by customer once signed and /or document # integrated into contractor, owner and/ or agents subcontract agreement and terms. In the event of DELINQUENT PAYMENT and/or BREACH of contract this action will VOID ALL WARRANTY. All government fees subject to \$85.00 hr. acquisition fee. Note: Not included in bid: 1. Unforeseen conditions. 2. No Dewatering 3. No winter protection. 4. No stabilization of soils. 5. No asbestos or radon testing or removal included.~~

**Acceptance of Proposal: The above prices, specifications and conditions are satisfactory and are hereby accepted. Merritt & Associates G C INC employees are fully covered by Workers Compensation Insurance and required Contractor's licensing and Liability Insurance coverage.**

**This proposal may be withdrawn if not accepted within 14 days.**

DocuSigned by:  
*Brian Holton*

**Merritt & Associates, G.C., Inc.**

DocuSigned by:  
*Duane Hoff Jr.*

**Client Signature/Title**

Date 7/28/2023



CITY OF GRAND JUNCTION, COLORADO

\*\*\*\*\*

**CONTRACT**

This CONTRACT made and entered into this 1<sup>st</sup> day of June 2023 by and between the **City of Grand Junction, Colorado**, a government entity in the County of Mesa, State of Colorado, hereinafter in the Contract Documents referred to as the "Owner" and **Merritt & Associates CG Inc** hereinafter in the Contract Documents referred to as the "Contractor."

WITNESSETH:

WHEREAS the Owner advertised sealed Bids would be received for furnishing all labor, tools, supplies, equipment, materials, and everything necessary and required for the Project described by the Contract Documents and known as the **Safety Bollard Purchase and Installation Project IFB-5244-23-KF**.

WHEREAS, the Contract has been awarded to the above-named Contractor by the Owner, and said Contractor is now ready, willing, and able to perform the Work specified in the Notice of Award, in accordance with the Contract Documents.

NOW, THEREFORE, in consideration of the compensation to be paid the Contractor, the mutual covenants hereinafter set forth and subject to the terms hereinafter stated, it is mutually covenanted and agreed as follows:

ARTICLE 1

**Contract Documents**: It is agreed by the parties hereto that the following list of instruments, drawings, and documents which are attached hereto, bound herewith, or incorporated herein by reference constitute and shall be referred to either as the "Contract Documents" or the "Contract", and all of said instruments, drawings, and documents taken together as a whole constitute the Contract between the parties hereto, and they are fully a part of this agreement as if they were set out verbatim and in full herein:

The order of contract document governance shall be as follows:

- a. The body of this Contract Agreement
- b. Solicitation Documents for the Project including all Addenda: **Safety Bollard Purchase and Installation Project IFB-5244-23-KF**;
- c. Notice of Award;
- d. Contractor's Response to the Solicitation;
- e. Work Change Requests (directing changed work be performed);
- f. Field Orders;

g. Change Orders.

ARTICLE 2

Definitions: The clauses provided in the Solicitation apply to the terms used in the Contract and all the Contract Documents.

ARTICLE 3

Contract Work: The Contractor agrees to furnish all labor, tools, supplies, equipment, materials, and all that is necessary and required to complete the tasks associated with the Work described, set forth, shown, and included in the Solicitation Documents.

ARTICLE 4

Contract Time and Liquidated Damages: Time is of the essence with respect to this Contract. The Contractor hereby agrees to commence Work under the Contract on or before the date specified in the Solicitation from the Owner, and to achieve Substantial Completion and Final Completion of the Work within the time or times specified in the Solicitation. In the event the Work is not completed in the times set forth and as agreed upon, the Contractor further agrees to pay Liquidated Damages to the Owner as set forth in the Solicitation. The Contractor acknowledges and recognizes the delays, expenses and difficulties involved in proving in a legal proceeding the actual losses suffered by the Owner if the work is not completed on time. Accordingly, instead of requiring any such proof, the Owner and the Contractor agree that as Liquidated Damages for delay, but not as a penalty, the Contractor shall pay to the Owner the amounts specified in the Solicitation.

ARTICLE 5

Contract Price and Payment Procedures: The Contractor shall accept as full and complete compensation for the performance and completion of all of the Work specified in the Contract Documents, the sum of **One Hundred Forty-Seven Thousand Two Hundred Fifty-Three and 20/100 Dollars (\$147,253.20)**. If this Contract contains unit price pay items, the Contract price shall be adjusted in accordance with the actual quantities of items completed and accepted by the Owner at the unit prices quoted in the Solicitation Response. The amount of the Contract Price is and has heretofore been appropriated by the Grand Junction City Council for the use and benefit of this Project. The Contract Price shall not be modified except by Change Order or another written directive of the Owner. The Owner shall not issue a Change Order or other written directive which requires additional work to be performed, which work causes the aggregate amount payable under this Contract to exceed the amount appropriated for this Project, unless and until the Owner provides Contractor written assurance that lawful appropriations to cover the costs of the additional work have been made.

Unless otherwise provided in the Solicitation, monthly partial payments shall be made as the Work progresses. Applications for partial and Final Payment shall be prepared by the Contractor and approved by the Owner in accordance with the Solicitation.



Upon Final Completion of the Work under the Contract and before the Contractor shall receive final payment, the Owner shall publish at least twice in the newspaper of general circulation published in the County a notice that: 1. the Owner has accepted such Work as completed according to the Contract Documents; 2. the Contractor is entitled to final payment therefore; 3. thirty (30) days after the first publication, specifying the exact date, the Owner shall pay the full balance due under the Contract; and 4. persons having claims for labor, materials, team hire, sustenance, provisions, provender, or other supplies used or consumed by the Contractor or a Subcontractor shall file a verified statement of the amount due and unpaid on account of such claim prior to the date specified for such payment. Nothing herein shall be construed as relieving the Contractor and the Sureties on the Contractor's Bonds from any claim or claims for work or labor done or materials or supplies furnished in the execution of the Contract.

#### ARTICLE 6

Bonds: The Contractor shall furnish currently herewith the Bonds required by the Contract Documents; such Bonds being attached hereto. The Performance Bond shall be in an amount not less than one hundred percent (100%) of the Contract Price set forth in Article 5. The Payment Bond shall be in an amount not less than one hundred percent (100%) of the Contract Price set forth in Article 5.

#### ARTICLE 7

Contract Binding: The Owner and the Contractor each bind itself, its partners, successors, assigns and legal representatives to the other party hereto in respect of all covenants, agreements and obligations contained in the Contract Documents. The Contract Documents constitute the entire agreement between the Owner and Contractor and may only be altered, amended, or repealed by a duly executed written instrument. Neither the Owner nor the Contractor shall, without the prior written consent of the other, assign or sublet in whole or in part its interest under any of the Contract Documents and specifically, the Contractor shall not assign any moneys due or to become due without the prior written consent of the Owner.

#### ARTICLE 8

Severability: If any part, portion, or provision of the Contract shall be found or declared null, void, or unenforceable for any reason whatsoever by any court of competent jurisdiction or any governmental agency having the authority thereover, only such part, portion or provision shall be affected thereby and all other parts, portions and provisions of the Contract shall remain in full force and effect.

IN WITNESS WHEREOF, City of Grand Junction, Colorado, has caused this Contract to be subscribed and sealed and attested on its behalf; and the Contractor has signed this Contract the day and the year first mentioned herein.

The Contract is executed in two counterparts.

**CITY OF GRAND JUNCTION, COLORADO**

DocuSigned by:  
By: Duane Hoff Jr.  
9F789E7D8CF14BC...  
Duane Hoff Jr., Contract Administrator

6/9/2023  
Date

**Merritt & Associates CG Inc**

DocuSigned by:  
By: Brian Holton  
23B689FE1D0E414...  
Brian Holton VP

6/9/2023  
Date



**NOTICE OF AWARD**

Date: June 1, 2023  
Company: Merritt & Associates CG Inc  
Project: Safety Bollard Purchase and Installation Project IFB-5244-23-KF

---

Merritt & Associates CG Inc has been awarded the City of Grand Junction Contract for the Safety Bollard Purchase and Installation Project (IFB-5244-23-KF) for a lump sum fee of **\$147,253.20**.

Please notify Kyle Coltrinari, General Services Manager at (970) 254-3889 or via email [kylec@gjcity.org](mailto:kylec@gjcity.org) for project scheduling. Send the current certificate of insurance, and Payment & Performance bonds to the City Purchasing Division within ten (10) calendar days in accordance with the contract documents.

CITY OF GRAND JUNCTION, COLORADO

DocuSigned by:

*Duane Hoff Jr.*

9F789E7D50F14BC...

Duane Hoff, Jr. Contracts Administrator

---

**SUPPLIER ACKNOWLEDGEMENT**

Receipt of this Notice to Award is hereby acknowledged:

Company: Merritt & Associates GC Inc.

DocuSigned by:

*Brian Holton*

Brian Holton

23B689FETD0E4T4...

By:

Title:

VP

Date:

6/9/2023

---



**Purchasing Division**

## **Invitation for Bid**

**IFB-5244-23-KF**

**Safety Bollard Purchase and Installation Project**

### **Responses Due:**

May 23, 2023, prior to 2:00 PM

**Accepting Electronic Responses Only**  
**Responses Only Submitted Through the**  
**Rocky Mountain E-Purchasing System (RMEPS)**  
<https://www.bidnetdirect.com/colorado>

**Purchasing Representative does not have access or control of the vendor side of RMEPS. If website or other problems arise during response submission, vendor MUST contact RMEPS to resolve issue prior to the response deadline. 800-835-4603**

**NOTE: All City solicitation openings will be held virtually.**

**Purchasing Representative:**  
Kathleen Franklin, Senior Buyer  
[kathleenf@gjcity.org](mailto:kathleenf@gjcity.org)  
970-244-1513

# **Invitation for Bid**

## **Table of Contents**

Section 1	Instructions to Offerors
Section 2	General Contract Conditions
Section 3	Statement of Work
Section 4	Contractor's Bid Form
	Price Bid Schedule Form
	Attachments (Click on Links)
	<a href="#"><u>A: City Hall Bollard Locations</u></a>
	<a href="#"><u>B: GJPD Bollard Placement</u></a>

# **1. Instructions to Offerors**

**NOTE:** It is the Contractor's responsibility to read and review all solicitation documentation in its entirety, and to ensure that it has a clear and complete understanding of not only the scope, specifications, project requirements, etc., but also all other requirements, instructions, rules, regulations, laws, conditions, statements, procurement policies, etc. that are associated with the solicitation process and project/services being solicited.

- 1.1. Issuing Office:** This Invitation for Bid (IFB) is issued by the City of Grand Junction. All contact regarding this IFB is to be directed to

Kathleen Franklin, Senior Buyer  
[kathleenf@gjcity.org](mailto:kathleenf@gjcity.org)

With the exception of Pre-Bid or Site Visit Meeting(s) all questions, inquiries, comments, or communication pertaining to this solicitation (whether process, specifications, scope, etc.) must be directed (in writing) to the Purchasing Agent. Other communication may result in disqualification.

- 1.2. Non-Mandatory Pre-Bid Site Walk Down Meeting:** Interested Contractors are strongly encouraged to attend a site visit inclusive of walking down each identified installation location for this Project. The purpose of this site visit meeting will be to inspect and clarify the contents of this Invitation for Bid (IFB). **The site visit will take place on May 4, 2023, at 9:00am starting at City Hall, located at 250 N 5<sup>th</sup> St, Grand Junction, CO and continue to Grand Junction Police Department (GJPD).** *Nothing stated during this site visit meeting will modify the solicitation. Only information provided in an addendum can modify the IFB.*
- 1.3. Purpose:** The City of Grand Junction is soliciting competitive bids from qualified and interested Contractors for all labor, equipment, materials, and supplies required for the purchase and installation of twenty (20) safety bollards. Nine (9) bollards will be installed at City Hall and eleven (11) will be installed at GJPD. All dimensions and Scope of Work should be verified by Contractors prior to submission of bids.
- 1.4. The Owner:** The Owner is the City of Grand Junction, Colorado and is referred to throughout this Solicitation. The term Owner means the Owner or authorized representative.
- 1.5. Compliance:** All Offerors, by submitting a bid, agree to comply with all conditions, requirements, and instruction of this IFB as stated or implied herein. Should the Owner omit anything which is necessary to the clear understanding of the requirements, or should it appear that various instructions are in conflict, the Offeror(s) shall secure instructions from the Purchasing Agent prior to submittal deadline.
- 1.6. Procurement Process:** The current version of the City of Grand Junction [Purchasing Policy and Procedure Manual](#) is contracting.
- 1.7. Submission:** **Each bid shall be submitted in electronic format only through the Rocky Mountain E-Purchasing website ([www.bidnetdirect.com/colorado](http://www.bidnetdirect.com/colorado)).** *This site*

*offers both “free” and “paying” registration options which allow for full access of the Owner’s documents and for electronic submission of bids. (NOTE: “free” registration may take up to 24 hours to process. Please Plan accordingly.)* Please view our “**Electronic Vendor Registration Guide**” at <http://www.gjcity.org/501/Purchasing-Bids> for details. Purchasing Representative does not have access or control of the vendor side of RMEPS. If website or other problems arise during response submission, vendor **MUST** contact RMEPS to resolve issue prior to the response deadline. **800-835-4603**.

Bids shall be formatted as directed in Section 4.0. Submittals that fail to follow this format may be ruled non-responsive.

Bid Opening, Safety Bollard Purchase and Installation Project IFB-5244-23-KF  
May 23, 2023, 2:00 – 2:30 PM (America/Denver)

Please join my meeting from your computer, tablet, or smartphone.

<https://meet.goto.com/540033701>

You can also dial in using your phone.

Access Code:

540-033-701

United States:

[+1 \(224\) 501-3412](tel:+12245013412)

Join from a video-conferencing room or system.

Meeting ID:

540-033-701

Dial in or type:

67.217.95.2 or [inroomlink.goto.com](https://inroomlink.goto.com)

Or dial directly:

540033701@67.217.95.2 or 67.217.95.2##540033701

**Get the app now and be ready when your first meeting starts:**

<https://meet.goto.com/install>

- 1.8. Modification and Withdrawal of Bids Before Opening:** Bids may be modified or withdrawn by an appropriate document stating such, duly executed and submitted to the place where Bids are to be submitted at any time prior to Bid Opening. Bids may not be altered, modified, or amended after submission date.
- 1.9. Form for Price Bid:** All Price Bids must be made upon the Price Bid Schedule attached and should give the amounts both in words and in figures and must be signed and acknowledged by the Offeror.

The Offeror shall specify a unit price in figures for each pay item for which a quantity is given and shall provide the products (in numbers) of the respective unit prices and quantities in the Extended Amount column. The total Bid price shall be equal to the sum of all extended amount prices. When an item in the Price Bid Schedule provides a choice to be made by the Offeror, Offeror's choice shall be indicated in accordance with the specifications for that particular item and thereafter no further choice shall be permitted.

Where the unit of a pay item is lump sum, the lump sum amount shall be shown in the "extended amount" column and included in the summation of the total Bid.

All blank spaces in the Price Bid Schedule must be properly filled out.

Bids by corporations must be executed in the corporate name by the president or vice president or other corporate office accompanied by evidence of authority to sign. The corporate address and state of incorporation shall be shown below the signature.

Bids by partnerships must be executed in the partnership name and signed by a partner whose title must appear under the signature and the official address of the partnership must be shown below the signature.

All names must be typed or printed below the signature.

The Offeror's Bid shall contain an acknowledgement of receipt of all Addenda, the numbers of which shall be filled in on the Contractor's Bid Form.

The contact information to which communications regarding the Bid are to be directed must be shown.

- 1.10. **Exclusions:** No oral, telephonic, emailed, or facsimile bid will be considered
- 1.11. **Contract Documents:** The complete IFB and Offeror's response compose the Contract Documents. Copies of bid documents can be obtained from the City Purchasing website, <https://co-grandjunction.civicplus.com/501/Purchasing-Bids>.
- 1.12. **Additional Documents:** The July 2010 edition of the "City Standard Contract Documents for Capital Improvements Construction", Plans, Specifications and other Bid Documents are available for review or download on the Purchasing Bids page at <https://co-grandjunction.civicplus.com/501/Purchasing-Bids>.
- 1.13. **Definitions and Terms:** See Article I, Section 3 of the General Contract Conditions in the *Standard Contract Documents for Capital Improvements Construction*.
- 1.14. **Examination of Specifications:** Offerors shall thoroughly examine and be familiar with the project Statement of Work. The failure or omission of any Offeror to receive or examine any form, addendum, or other document shall in no way relieve any Offeror from any obligation with respect to its bid. The submission of a bid shall be taken as evidence of compliance with this section. Prior to submitting a bid, each Offeror shall, at a minimum:
  - a. Examine the *Contract Documents* thoroughly;
  - b. Visit the site to familiarize itself with local conditions that may in any manner affect cost, progress, or performance of the Work;
  - c. Study and carefully correlate Offeror's observations with the *Contract Documents*, and;



- d. Notify the Purchasing Agent of all conflicts, errors, ambiguities, or discrepancies in or among the *Contract Documents* within the designated inquiry period.

On request, the Owner will provide each Offeror access to the site to conduct such investigations and tests as each Offeror deems necessary for submission of a Bid. It shall be the Offeror's responsibility to make or obtain any additional examinations, investigations, explorations, tests and studies and obtain any additional information and data which pertain to the physical conditions (including without limitation, surface, subsurface and underground utilities) at or contiguous to the site or otherwise which may affect cost, progress or performance of the Work and which the Offeror deems necessary to determine its Bid for performing the Work in accordance with the time, price and other terms and conditions of the *Contract Documents*. Location of any excavation or boring made by Offeror shall be subject to prior approval of Owner and applicable agencies. Offeror shall fill all holes, restore all pavements to match the existing structural section and shall clean up and restore the site to its former condition upon completion of such exploration. The Owner reserves the right to require the Offeror to execute an access agreement with the Owner prior to accessing the site.

The lands upon which the Work is to be performed, rights of way, and access thereto, and other lands designated for use by Contractor in performing the Work, are identified on the Drawings.

Information and data reflected in the *Contract Documents* with respect to underground utilities at or contiguous to the site are based upon information and data furnished to the Owner and the Engineer by the owners of such underground utilities or others, and the Owner does not assume responsibility for the accuracy or completeness thereof, unless it is expressly provided otherwise in the *Contract Documents*.

By submission of a Bid, the Offeror shall be conclusively presumed to represent that the Offeror has complied with every requirement of these Instructions to Offerors, that the *Contract Documents* are not ambiguous and are sufficient in scope and detail to indicate and convey understanding of all terms and conditions for performance of the Work.

- 1.15. Questions Regarding Statement of Work:** Any information relative to interpretation of Scope of Work or specifications shall be requested of the Purchasing Agent, in writing, in ample time, prior to the inquiry deadline.
- 1.16. Addenda & Interpretations:** If it becomes necessary to revise any part of this solicitation, a written addendum will be posted electronically on the City's website at <https://co-grandjunction.civicplus.com/501/Purchasing-Bids>. The Owner is not bound by any oral representations, clarifications, or changes made in the written specifications by Owner, unless such clarification or change is provided in written addendum form from the City Purchasing Representative.
- 1.17. Taxes:** The Owner is exempt from State, County, and Municipal Sales Tax and Federal Excise Tax, therefore, all fees shall not include taxes.
- 1.18. Sales and Use Taxes:** The Contractor and all Sub-Contractors are required to obtain exemption certificates from the Colorado Department of Revenue for sales and use taxes

in accordance with the provisions of the General Contract Conditions Section XVI "Taxes". Bids shall reflect this method of accounting for sales and use taxes on materials, fixtures, and equipment.

- 1.19. Offers Binding 60 Days:** Unless additional time is required by the Owner, or otherwise specified, all formal offers submitted shall be binding for sixty (60) calendar days following opening date, unless the Offeror, upon request of the Purchasing Representative, agrees to an extension.
- 1.20. Exceptions and Substitutions:** All bids meeting the intent of this IFB shall be considered for award. An Offeror taking exception to the specifications does so at the Offeror's risk. The Owner reserves the right to accept or reject any or all substitutions or alternatives. When offering substitutions and/or alternatives, Offeror must state any exception(s) in the section to which the exception(s) pertain. Exception/substitution, if accepted, must meet, or exceed the stated intent and/or specifications. The absence of stated exception(s) indicates that the Offeror has not taken exceptions, and if awarded a Contract shall hold the Offeror responsible to perform in strict accordance with the specifications or scope of the bid and Contract Documents.
- 1.21. Collusion Clause:** Each Offeror by submitting a bid certifies that it is not party to any collusive action or any action that may be in violation of the Sherman Antitrust Act. Any and all bids shall be rejected if there is evidence or reason for believing that collusion exists among Offerors. The Owner may, or may not, at its discretion, accept future bids for the same Work or commodities from participants in such collusion.
- 1.22. Disqualification of Offerors:** A Bid will not be accepted from, nor shall a Contract be awarded to, any person, firm, or corporation that is in arrears to the Owner, upon debt or Contract, or that has defaulted, as surety or otherwise, upon any obligation to the Owner, or that is deemed irresponsible or unreliable.

Offerors may be required to submit satisfactory evidence that it is responsible, have a practical knowledge of the project bid upon and has the necessary financial and other resources to complete the proposed Work.

Either of the following reasons, without limitation, shall be considered sufficient to disqualify an Offeror and Bid:

- a. More than one Bid is submitted for the same Work from an individual, firm, or corporation under the same or different name; and
  - b. Evidence of collusion among Offerors. Any participant in such collusion shall not receive recognition as an Offeror for any future Work of the Owner until such participant has been reinstated as a qualified Offeror.
- 1.23. Public Disclosure Record:** If the Offeror has knowledge of its employee(s) or Sub-Contractors having an immediate family relationship with an Owner employee or elected official, the Offeror must provide the Purchasing Agent with the name(s) of the individuals. The individuals are required to file a "Public Disclosure Record", a statement of financial interest, before conducting business with the Owner.

## **2. General Contract Conditions for Construction Projects**

- 2.1. The Contract:** This Invitation for Bid, submitted documents, and any negotiations, when properly accepted by the Owner, shall constitute an enforceable agreement equally binding between the Owner and Contractor. The Contract represents the entire and integrated agreement between the Owner and the Contractor and supersedes all prior negotiations, representations, or agreements, either written or oral, including the Bid documents. The Contract may be amended or modified with Change Orders, Field Orders, or Addendums.
- 2.2. The Work:** The term Work includes all labor necessary to produce the construction required by the Contract Documents, and all materials and equipment incorporated or to be incorporated in such construction.
- 2.3. Execution, Correlation, Intent, and Interpretations:** The Contract Documents shall be signed by the Owner and Contractor. By executing the Contract, the Contractor represents that it has familiarized itself with the local conditions under which the Work is to be performed and correlated its observations with the requirements of the Contract Documents. The Contract Documents are complementary, and what is required by anyone, shall be as binding as if required by all. The intention of the Contract Documents is to include all labor, materials, equipment, services, and other items necessary for the proper execution and completion of the Scope of Work as defined in the technical specifications and/or drawings contained herein. All drawings, specifications and copies furnished by the Owner are, and shall remain, Owner property. It is not to be used on any other project.
- 2.4. The Owner:** The Owner is the City of Grand Junction, Colorado and is referred to throughout the Contract Documents. The term Owner means the Owner or authorized representative. The Owner shall, at all times, have access to the Work wherever it is in preparation and progress. The Contractor shall provide facilities for such access. The Owner will make periodic visits to the site to familiarize itself generally with the progress and quality of Work and to determine, in general, if the Work is proceeding in accordance with the Contract Documents. Based on such observations and the Contractor's Application for Payment, the Owner will determine the amounts owing to the Contractor and will issue Certificates for Payment in such amounts, as provided in the Contract. The Owner will have authority to reject Work which does not conform to the Contract documents. Whenever, in its reasonable opinion, it considers it necessary or advisable to ensure the proper implementation of the intent of the Contract Documents, it will have authority to require the Contractor to stop the Work or any portion, or to require special inspection or testing of the Work, whether or not such Work can be then be fabricated, installed, or completed. The Owner will not be responsible for the acts or omissions of the Contractor, and Sub-Contractor, or any of its agents or employees, or any other persons performing any of the Work.
- 2.5. Contractor:** The Contractor is the person or organization identified as such in the Agreement and is referred to throughout the Contract Documents. The term Contractor means the Contractor or its authorized representative. The Contractor shall carefully study and compare the General Contract Conditions of the Contract, Specification and Drawings, Scope of Work, Addenda and Modifications and shall at once report to the

Owner any error, inconsistency, or omission it may discover. Contractor shall not be liable to the Owner for any damage resulting from such errors, inconsistencies, or omissions. The Contractor shall not commence Work without clarifying Drawings, Specifications, or Interpretations.

- 2.6. Sub-Contractors:** A Sub-Contractor is a person or organization who has a direct Contract with the Contractor to perform any of the Work at the site. The term Sub-Contractor is referred to throughout the contract documents and means a Sub-Contractor or its authorized representative.
- 2.7. Award of Sub-Contractors & Other Contracts for Portions of the Work:** Contractor shall submit with its bid response to the Owner, in writing for acceptance, a list of the names of the sub-contractors or other persons or organizations proposed for such portions of the Work as may be designated in the bid requirements, or, if none is so designated, the names of the sub-contractors proposed for the principal portions of the Work. Prior to the award of the Contract, the Owner shall notify the successful Contractor in writing if, after due investigation, has reasonable objection to any person or organization on such list. If, prior to the award of the Contract, the Owner has a reasonable and substantial objection to any person or organization on such list and refuses in writing to accept such person or organization, the successful Contractor may, prior to the award, withdraw its bid without forfeiture of bid security. If the successful Contractor submits an acceptable substitute with an increase in the proposed price to cover the difference in cost occasioned by the substitution, the Owner may, at its discretion, accept the increased bid or may disqualify the Contractor. If, after the award, the Owner refuses to accept any person or organization on such list, the Contractor shall submit an acceptable substitute and the Contract sum shall be increased or decreased by the difference in cost occasioned by such substitution and an appropriate Change Order shall be issued. However, no increase in the Contract sum shall be allowed for any such substitution unless the Contractor has acted promptly and responsively in submitting a name with respect thereto prior to the award.
- 2.8. Quantities of Work and Unit Price:** Materials or quantities stated as unit price items in the Bid are supplied only to give an indication of the general scope of the Work, and are as such, estimates only. The Owner does not expressly or by implication agree that the actual amount of Work or material will correspond therewith and reserves the right after award to increase or decrease the quantity of any unit item of the Work without a change in the unit price except as set forth in Article VIII, Section 70 of the *General Contract Conditions*. The City also reserves the right to make changes in the Work (including the right to delete any bid item in its entirety or add additional bid items) as set forth in Article VIII, Sections 69 through 71 of the *General Contract Conditions*.
- 2.9. Substitutions:** The materials, products and equipment described in the *Solicitation Documents* shall be regarded as establishing a standard of required performance, function, dimension, appearance, or quality to be met by any proposed substitution. No substitution will be considered prior to receipt of Bids unless the Offeror submits a written request for approval to the Purchasing Agent at least ten (10) days prior to the date for receipt of Bids. Such requests for approval shall include the name of the material or equipment for which substitution is sought and a complete description of the proposed substitution including drawings, performance and test data, and other information

necessary for evaluation, including samples if requested. The Offeror shall set forth changes in other materials, equipment, or other portions of the Work including changes of the Work of other Contracts, which incorporation of the proposed substitution would require to be included. The Owner's decision of approval or disapproval of a proposed substitution shall be final. If the Owner approves a proposed substitution before receipt of Bids, such approval will be set forth in an Addendum. Offerors shall not rely upon approvals made in any other manner.

- 2.10. Supervision and Construction Procedures:** The Contractor shall supervise and direct the Work, using its best skill and attention. The Contractor shall be solely responsible for all construction means, methods, techniques, sequences, and procedures and for coordinating all portions of the Work under the Contract.
- 2.11. Warranty:** The Contractor warrants to the Owner that all materials and equipment furnished under this Contract will be new unless otherwise specified, and that all Work will be of good quality, free from faults and defects and in conformance with the Contract Documents. All Work not conforming to these standards may be considered defective. If required by Owner, the Contractor shall furnish satisfactory evidence as to the kind and quality of materials and equipment. If within ten (10) days after written notice to the Contractor requesting such repairs or replacement, the Contractor should neglect to make or undertake with due diligence to the same, the Owner may make such repairs or replacements. All indirect and direct costs of such correction or removal or replacement shall be at the Contractor's expense. The Contractor will also bear the expenses of making good all Work of others destroyed or damaged by the correction, removal, or replacement of its defective Work.
- 2.12. Permits, Fees, & Notices:** The Contractor shall secure and pay for all permits, governmental fees, and licenses necessary for the proper execution and completion of the Work. The Contractor shall give all notices and comply with all laws, ordinances, rules, regulations, and orders of any public authority, including the City, bearing on the performance of the Work. If the Contractor observes that any of the Contract Documents are at variance in any respect, it shall promptly notify the Purchasing Agent in writing, and any necessary changes shall be adjusted. If the Contractor performs any Work knowing it to be contrary to such laws, ordinances, rules, and regulations, and without such notice to the Owner, it shall assume full responsibility and shall bear all costs attributable to the non-conforming Work.
- 2.13. Responsibility for Those Performing the Work:** The Contractor shall be responsible to the Owner for the acts and omissions of all its employees and all Sub-Contractors, its agents and employees, and all other persons performing any of the Work under a Contract with the Contractor.
- 2.14. Use of the Site:** The Contractor shall confine operations at the site to areas permitted by law, ordinances, permits and the Contract Documents, and shall not unreasonably encumber the site with any materials or equipment.
- 2.15. Cleanup:** The Contractor at all times shall keep the premises free from accumulation of waste materials or rubbish caused by operations. At the completion of Work, shall remove

all waste materials and rubbish from and about the project, as well as all tools, construction equipment, machinery, and surplus materials.

**2.16. Insurance Requirements:** The selected Contractor agrees to procure and maintain, at its own cost, policy(s) of insurance sufficient to insure against all liability, claims, demands, and other obligations assumed by the Contractor pursuant to the Contract. Such insurance shall be in addition to any other insurance requirements imposed by this Contract or by law. The Contractor shall not be relieved of any liability, claims, demands, or other obligations assumed pursuant to the Contract by reason of its failure to procure or maintain insurance in sufficient amounts, durations, or types.

Contractor shall procure and maintain and, if applicable, shall cause any Sub-Contractor of the Contractor to procure and maintain insurance coverage listed below. Such coverage shall be procured and maintained with forms and insurers acceptable to Owner. All coverage shall be continuously maintained to cover all liability, claims, demands, and other obligations assumed by the Contractor pursuant to the Contract. In the case of any claims-made policy, the necessary retroactive dates and extended reporting periods shall be procured to maintain such continuous coverage. Minimum coverage limits shall be as indicated below unless specified otherwise in the Special Conditions:

(a) Worker Compensation: Contractor shall comply with all State of Colorado Regulations concerning Workers' Compensation insurance coverage.

(b) General Liability insurance with minimum limits of:

FIVE HUNDRED THOUSAND DOLLARS (\$500,000) each occurrence and  
FIVE HUNDRED THOUSAND DOLLARS (\$500,000) per job aggregate.

The policy shall be applicable to all premises, products, and completed operations. The policy shall include coverage for bodily injury, broad form property damage (including completed operations), personal injury (including coverage for contractual and employee acts), blanket contractual, products, and completed operations. The policy shall include coverage for explosion, collapse, and underground (XCU) hazards. The policy shall contain a severability of interest's provision.

(c) Comprehensive Automobile Liability insurance with minimum limits for bodily injury and property damage of not less than:

FIVE HUNDRED THOUSAND DOLLARS (\$500,000) each occurrence and  
FIVE HUNDRED THOUSAND DOLLARS (\$500,000) aggregate

(d) Professional Liability & Errors and Omissions Insurance policy with a minimum of:

FIVE HUNDRED THOUSAND DOLLARS (\$500,000) per claim

This policy shall provide coverage to protect the City against liability incurred as a result of the Work performed as a result of responding to this Solicitation. With respect to each of Contractors owned, hired, or non-owned vehicles assigned to be used in performance of the Work. The policy shall contain a severability of interest provision.

- 2.161 Additional Insured Endorsement:** The policies required by paragraphs (b), and (c) above shall be endorsed to include Grand Junction, its Elected and Appointed Officials, Employees and Volunteers as Additional Insured. Every required policy above shall be primary insurance, and any insurance carried by the Owner, its officers, or its employees, or carried by or provided through any insurance pool of the Owner, shall be excess and not contributory insurance to that provided by the Contractor. The Contractor shall be solely responsible for any deductible losses under any policy required above.
- 2.17. Indemnification:** The Contractor shall defend, indemnify and save harmless the Owner, and all its officers, employees, insurers, and self-insurance pool, from and against all liability, suits, actions, or other claims of any character, name and description brought for or on account of any injuries or damages received or sustained by any person, persons, or property on account of any negligent act or fault of the Contractor, or of any Contractor's agent, employee, Sub-Contractor or supplier in the execution of, or performance under, any Contract which may result from bid award. Contractor shall pay any judgment with costs which may be obtained by and/or against the Owner growing out of or under the performance.
- 2.18. Miscellaneous Conditions: Material Availability:** Contractors must accept responsibility for verification of material availability, production schedules, and other pertinent data prior to submission of bid. It is the responsibility of the Offeror to notify the Owner immediately if materials specified are discontinued, replaced, or not available for an extended period of time.
- 2.19. Time:** Time is of the essence with respect to the time of completion of the Project and any other milestones or deadline which are part of the Contract. It will be necessary for each Offeror to satisfy the City of its ability to complete the Work within the Contract Time set forth in the Contract Documents. The Contract Time is the period of time allotted in the Contract Documents for completion of the Work. The date of commencement of the Work is the date established in a Notice to Proceed. If there is no Notice to Proceed, it shall be the date of the Contract, or such other date as may be established therein, or as established as entered on the Bid Form. The Date of Final Completion of the Work is the date certified by the Owner when all construction, and all other Work associated to include, but not be limited to: testing, QA/QC, receipt of required reports and/or forms, grant requirements (if applicable), punch list items, clean-up, receipt of drawings and/or as-builts, etc., is fully complete, and in accordance with the Contract Documents.
- 2.20. Progress & Completion:** The Contractor will begin Work on the Commencement Date as noted on the Notice to Proceed and perform the Work expeditiously with adequate forces to complete the Work within the Contract Time/by the Completion Date.
- 2.21. Payment & Completion:** The Contract Sum is stated in the Contract and is the total amount payable by the Owner to the Contractor for the performance of the Work under the Contract Documents. Upon receipt of written notice that the Work is ready for final inspection and acceptance and upon receipt of application for payment, the Owner's Project Manager will promptly make such inspection and, when it finds the Work acceptable under the Contract Documents and the Contract fully performed, the Owner shall make payment in the manner provided in the Contract Documents.

**2.22. Bid Bond:** Each bid shall as a guaranty of good faith on the part of the Offeror be accompanied by a Bid Guaranty consisting of a certified or cashier's check drawn on an approved national bank or trust company in the state of Colorado and made payable without condition to the City; or a **Bid Bond** written by an approved corporate surety in favor of the City. The amount of the Bid Guaranty shall not be less than 5% of the total Bid amount. Once a Bid is accepted and a Contract is awarded, the apparent successful Offeror has ten calendar days to enter into a Contract in the form prescribed and to furnish the bonds with a legally responsible and approved surety. Failure to do so will result in forfeiture of the Bid Guaranty to the City as Liquidated Damages.

Each Offeror shall guaranty its total bid price for a period of sixty (60) Calendar Days from the date of the bid opening.

**2.23. Performance & Payment Bonds:** Contractor shall furnish a Performance and a Payment Bond, each in an amount at least equal to that specified for the Contract amount as security for the faithful performance and payment of all Contractor's obligations under the Contract Documents. These bonds shall remain in effect for the duration of the Warranty Period (as specified in the Special Conditions). Contractor shall also furnish other bonds that may be required by the Special Conditions. All bonds shall be in the forms prescribed by the Contract Documents and be executed by such sureties as (1) are licensed to conduct business in the State of Colorado and (2) are named in the current list of "Companies Holding Certificates of Authority as Acceptable Sureties on Federal Bonds and as Acceptable Reinsuring Companies" as published in Circular 570 (amended) by the Audit Staff, Bureau of Accounts, U.S. Treasury Department. All bonds signed by an agent must be accompanied by a certified copy of the Authority Act. If the surety on any bond furnished by the Contractor is declared bankrupt, or becomes insolvent, or its rights to do business in Colorado are terminated, or it ceases to meet the requirements of clauses (1) and (2) of this section, Contractor shall within five (5) days thereafter substitute another bond and surety, both of which shall be acceptable to the City.

**2.24. Retention:** The Owner shall deduct money from the partial payments in amounts considered necessary to protect the interest of the Owner and will retain this money until after completion of the entire Contract. The amount to be retained from partial payments will be five (5) percent of the value of the completed Work, and not greater than five (5) percent of the amount of the Contract. When the retainage has reached five (5) percent of the amount of the Contract no further retainage will be made and this amount will be retained until such time as final payment is made.

**2.25. Liquidated Damages for Failure to Enter Into Contract:** Should the Successful Offeror fail or refuse to enter into the Contract within ten (10) Calendar Days from the issuance of the Notice of Award, the City shall be entitled to collect the amount of such Offeror's Bid Guaranty as Liquidated Damages, not as a penalty but in consideration of the mutual release by the City and the Successful Offeror of all claims arising from the City's issuance of the Notice of Award and the Successful Offeror's failure to enter into the Contract and the costs to award the Contract to any other Offeror, to re-advertise, or otherwise dispose of the Work as the City may determine best serves its interest.



**2.26. Liquidated Damages for Failure to Meet Project Completion Schedule:** If the Contractor does not achieve Final Completion by the required date, whether by neglect, refusal or any other reason, the parties agree and stipulate that the Contractor shall pay liquidated damages to the City for each such day that final completion is late. As provided elsewhere, this provision does not apply for delays caused by the City. The date for Final Completion may be extended in writing by the Owner.

The Contractor agrees that as a part of the consideration for the City's awarding of this Contract liquidated damages in the daily amount of **\$350.00** is reasonable and necessary to pay for the actual damages resulting from such delay. The parties agree that the real costs and injury to the City for such delay include hard to quantify items such as: additional engineering, inspection and oversight by the City and its agents; additional Contract administration; inability to apply the efforts of those employees to the other Work of the City; perceived inefficiency of the City; citizens having to deal with the construction and the Work, rather than having the benefit of a completed Work, on time; inconvenience to the public; loss of reputation and community standing for the City during times when such things are very important and very difficult to maintain.

The Contractor must complete the Work and achieve final completion included under the Bid Schedule in the number of consecutive calendar days after the City gives is written Notice to Proceed. When the Contractor considers the entire Work ready for its intended use, Contractor shall certify in writing that the Work is fully complete. Final Completion date is the date by which the Contractor shall have fully completed all clean-up, and all items that were identified by the City in the inspection for final completion. Unless otherwise stated in the Special Conditions, for purposes of this liquidated damages clause, the Work shall not be finished, and the Contract time shall continue to accrue until the City gives its written Final Acceptance.

If the Contractor fails to pay said liquidated damages promptly upon demand thereof after having failed to achieve Final Completion on time, the City shall first look to any retainage or other funds from which to pay said liquidated damages; if retainage or other liquid funds are not available to pay said liquidated damages amounts, the Surety on the Contractor's Performance Bond and Payment Bond shall pay such liquidated damages. In addition, the City may withhold all, or any part of, such liquidated damages from any payment otherwise due the Contractor.

Liquidated damages as provided do not include any sums to reimburse the City for extra costs which the City may become obligated to pay on other Contracts which were delayed or extended because of the Contractor's failure to complete the Work within the Contract Time. Should the City incur additional costs because of delays or extensions to other Contracts resulting from the Contractor's failure of timely performance, the Contractor agrees to pay these costs that the City incurs because of the Contractor's delay, and these payments are separate from and in addition to any liquidated damages.

The Contractor agrees that the City may use its own forces or hire other parties to obtain Final Completion of the Work if the time of completion has elapsed and the Contractor is not diligently pursuing completion. In addition to the Liquidated Damages provided for, the Contractor agrees to reimburse the City for all expenses thus incurred.

- 2.27. Contingency/Force Account/Minor Contract Revisions:** Contingency/Force Account/Minor Contract Revisions Work will be authorized by the Owner's Project Manager and is defined as minor expenses to cover miscellaneous or unforeseen expenses related to the project. The expenses are not included in the Drawings, Specifications, or Scope of Work and are necessary to accomplish the scope of this Contract. Contingency/Force Account/Minor Contract Revisions Authorization will be directed by the Owner through an approved form. Contingency/Force Account/Minor Contract Revisions funds are the property of the Owner and any Contingency/Force Account/Minor Contract Revisions funds, not required for project completion, shall remain the property of the Owner. Contractor is not entitled to any Contingency/Force Account/Minor Contract Revisions funds, which are not authorized by Owner or Owner's Project Manager.
- 2.28. Protection of Persons & Property:** The Contractor shall comply with all applicable laws, ordinances, rules, regulations, and orders of any public authority having jurisdiction for the safety of persons or property or to protect it from damage, injury, or loss. Contractor shall erect and maintain, as required by existing safeguards for safety and protection, and all reasonable precautions, including posting danger signs or other warnings against hazards promulgating safety regulations and notifying owners and users of adjacent utilities. When or where any direct or indirect damage or injury is done to public or private property by or on account of any act, omission, neglect, or misconduct by the Contractor in the execution of the Work, or in consequence of the non-execution thereof by the Contractor, it shall restore, at its own expense, such property to a condition similar or equal to that existing before such damage or injury was done, by repairing, rebuilding, or otherwise restoring as may be directed, or shall make good such damage or injury in an acceptable manner.
- 2.29. Changes in the Work:** The Owner, without invalidating the Contract, may order changes in the Work within the general scope of the Contract consisting of additions, deletions or other revisions, the Contract sum, and the Contract time being adjusted accordingly. All such changes in the Work shall be authorized by Change Order and shall be executed under the applicable conditions of the Contract documents. A Change Order is a written order to the Contractor signed by the Owner issued after the execution of the Contract, authorizing a change in the Work or an adjustment in the Contract sum or the Contract time. The Contract sum and the Contract time may be changed only by Change Order.
- 2.30. Claims for Additional Cost or Time:** If the Contractor wishes to make a claim for an increase in the Contract sum or an extension in the Contract time, it shall give the Owner written notice thereof within a reasonable time after the occurrence of the event giving rise to such claim. This notice shall be given by the Contractor before proceeding to execute the Work, except in an emergency endangering life or property in which case the Contractor shall precede in accordance with the regulations on safety. No such claim shall be valid unless so made. Any change in the Contract sum or Contract time resulting from such claim shall be authorized by Change Order.
- 2.31. Minor Changes in the Work:** The Owner shall have authority to order minor changes in the Work not involving an adjustment in the Contract sum or an extension of the Contract time and not inconsistent with the intent of the Contract Documents.

- 2.32. Field Orders:** The Owner may issue written Field Orders which interpret the Contract Documents in accordance with the specifications, or which order minor changes in the Work in accordance with the agreement, without change in the Contract sum or time. The Contractor shall conduct such Field Orders promptly.
- 2.33. Uncovering & Correction of Work:** The Contractor shall promptly correct all Work rejected by the Owner as defective or as failing to conform to the Contract Documents whether observed before or after substantial completion and whether or not fabricated installed or competed. The Contractor shall bear all costs of correcting such rejected Work, including the cost of the Owner's additional services thereby made necessary. If within one (1) year after the date of completion or within such longer period of time as may be prescribed by law or by the terms of any applicable special guarantee required by the Contract Documents, any of the Work found to be defective or not in accordance with the Contract Documents, the Contractor shall correct it promptly after receipt of a written notice from the Owner to do so unless the Owner has previously given the Contractor a written acceptance of such condition. The Owner shall give such notice promptly after discovering of condition. All such defective or non-conforming Work under the above paragraphs shall be removed from the site where necessary and the Work shall be corrected to comply with the Contract Documents without cost to the Owner. The Contractor shall bear the cost of making good all Work of separate Contractors destroyed or damaged by such removal or correction. If the Owner prefers to accept defective or non-conforming Work, it may do so instead of requiring its removal and correction, in which case a Change Order will be issued to reflect an appropriate reduction in the payment or Contract sum, or, if the amount is determined after final payment, it shall be paid by the Contractor.
- 2.34. Amendment:** No oral statement of any person shall modify or otherwise change, or affect the terms, conditions or specifications stated in the resulting Contract. All amendments to the Contract shall be made in writing by the Owner.
- 2.35. Assignment:** The Contractor shall not sell, assign, transfer, or convey the Contract resulting from this IFB, in whole or in part, without the prior written approval from the Owner.
- 2.36. Compliance with Laws:** Offers must comply with all Federal, State, County and local laws governing the Work and the fulfillment of the Work for and on behalf of the public. Contractor hereby warrants that it is qualified to assume the responsibilities and render the Work described herein and has all requisite corporate authority and professional licenses in good standing required by law.
- 2.37. Confidentiality:** All information disclosed by the Owner to the Contractor for the purpose of the Work to be done or information that comes to the attention of the Contractor during the course of performing such Work is to be kept strictly confidential.
- 2.38. Conflict of Interest:** No public official and/or Owner employee shall have interest in the Contract resulting from this Invitation For Bid.
- 2.39. Contract Termination:** The Contract shall remain in effect until any of the following occurs: (1) Contract expires; (2) completion of Work; (3) final acceptance of Work or, (4)

for convenience terminated by either party with a written *Notice of Cancellation* stating therein the reasons for such cancellation and the effective date of cancellation at least thirty (30) days past notification.

- 2.40. Employment Discrimination:** During the performance of any Work per agreement with the Owner, the Contractor, by submitting a Bid, agrees to:
- 2.40.1.** Not discriminate against any employee or applicant for employment because of race, religion, color, sex, age, handicap, or national origin except when such condition is a legitimate occupational qualification reasonably necessary for the normal operations of the Contractor. The Contractor agrees to post in conspicuous places, visible to employees and applicants for employment, notices setting forth the provisions of this nondiscrimination clause.
  - 2.40.2.** In all solicitations or advertisements for employees placed by or on behalf of the Contractor, that the Contractor is an Equal Opportunity Employer.
  - 2.40.3.** Notices, advertisements, and solicitations placed in accordance with federal law, rule, or regulation shall be deemed sufficient for the purpose of meeting the requirements of this section.
- 2.41. Affirmative Action:** In executing a Contract with the City, the Contractor agrees to comply with Affirmative Action and Equal Employment Opportunity regulations presented in the General Contract Conditions Section 9 "Affirmative Action/EEO."
- 2.42. Immigration Reform and Control Act of 1986 and Immigration Compliance:** The Contractor certifies that it does not and will not during the performance of the Contract employ workers without authorization or otherwise violate the provisions of the Federal Immigration Reform and Control Act of 1986 and/or laws regulating immigration compliance.
- 2.43. Ethics:** The Contractor shall not accept or offer gifts or anything of value and/or enter into any business arrangement with any employee, official, or agent of the Owner.
- 2.44. Failure to Deliver:** In the event of failure of the Contractor to perform in accordance with the Contract Documents, the Owner, after due oral or written notice, may procure the Work from other sources and hold the Contractor responsible for any and all costs resulting in the purchase of additional services and materials necessary to perform the Work. This remedy shall be in addition to any other remedies that the Owner may have.
- 2.45. Failure to Enforce:** Failure by the Owner at any time to enforce the provisions of the Contract shall not be construed as a waiver of any such provisions. Such failure to enforce shall not affect the validity of the Contract or any part thereof or the right of the Owner to enforce any provision of the Contract Documents at any time in accordance with the terms thereof.
- 2.46. Force Majeure:** The Contractor shall not be held responsible for failure to perform the duties and responsibilities imposed by the Contract due to legal strikes, fires, riots,

rebellions, and acts of God beyond the control of the Contractor, unless otherwise specified in the Contract.

**2.47. Independent Contractor:** The Contractor shall be legally considered an Independent Contractor and neither the Contractor nor its employees shall, under any circumstances, be considered servants or agents of the Owner. The Owner shall be at no time legally responsible for any negligence or other wrongdoing by the Contractor, its servants, or agents. The Owner shall not withhold from the Contract payments to the Contractor any federal or state unemployment taxes, federal or state income taxes, Social Security, or any other amounts for benefits to the Contractor. Further, the Owner shall not provide to the Contractor any insurance coverage or other benefits, including Workers' Compensation, normally provided by the Owner for its employees.

**2.48. Nonconforming Terms and Conditions:** A bid that includes terms and conditions that do not conform to the terms and conditions of this Invitation for Bid is subject to rejection as non-responsive. The Owner reserves the right to permit the Offeror to withdraw nonconforming terms and conditions from its bid prior to a determination by the Owner of non-responsiveness based on the submission of nonconforming terms and conditions.

Items for non-responsiveness may include, but not be limited to:

- a. Submission of the Bid on forms other than those supplied by the City;
- b. Alteration, interlineation, erasure, or partial detachment of any part of the forms which are supplied herein;
- c. Inclusion of unauthorized additions conditional or alternate Bids or irregularities of any kind which may tend to make the Bid incomplete, indefinite, or ambiguous as to its meaning;
- d. Failure to acknowledge receipt of any or all issued Addenda;
- e. Failure to provide a unit price or a lump sum price, as appropriate, for each pay item listed except in the case of authorized alternative pay items;
- f. Failure to list the names of Sub-Contractors used in the Bid preparation as may be required in the Solicitation Documents;
- g. Submission of a Bid that, in the opinion of the Owner, is unbalanced so that each item does not reasonably carry its own proportion of cost, or which contains inadequate or unreasonable prices for any item;
- h. Tying of the Bid with any other bid or Contract; and
- i. Failure to calculate Bid prices as described herein.

**2.49. Evaluation of Bids and Offerors:** The Owner reserves the right to:

- reject any and all Bids,
- waive any and all informalities,
- take into account any prompt payment discounts offered by Offeror,
- negotiate final terms with the Successful Offeror,
- take into consideration past performance of previous awards/Contracts with the Owner of any Contractor, Vendor, Firm, Supplier, or Service Provider in determining final award. and
- disregard any and all nonconforming, nonresponsive, or conditional Bids.

Discrepancies between words and figures will be resolved in favor of words. Discrepancies between Unit Prices and Extended Prices will be resolved in favor of the Unit Prices. Discrepancies between the indicated sum of any column of figures and the correct sum thereof will be resolved in favor of the correct sum. The corrected extensions and totals will be shown in the tabulation of Bids.

The Owner may consider the qualifications and experience of Sub-Contractors and other persons and organizations (including those who are to furnish the principal items of material or equipment) proposed for those portions of the Work as to which the identity of Sub-Contractors and other persons and organizations must be submitted. Operating costs, maintenance considerations performance data, and guarantees of materials and equipment may also be considered by the Owner.

The Owner will conduct such investigations as deemed necessary to assist in the evaluation of any Bid and to establish the responsibility, qualifications, and financial ability of the Offeror, proposed Sub-Contractors and other persons and organizations to do the Work in accordance with the *Contract Documents* to the City's satisfaction within the Contract Time.

The Offeror shall furnish the Owner all information and data requested by the Owner to determine the ability of the Offeror to perform the Work. The Owner reserves the right to reject the Bid if the evidence submitted by, or investigation of such Offeror fails to satisfy the Owner that such Offeror is properly qualified to carry out the obligations of the Contract and to complete the Work contemplated therein.

By submitting a Bid, each Offeror authorizes the Owner to perform such investigation of the Offeror as the Owner deems necessary to establish the responsibility, qualifications, and financial ability of the Offeror and, by its signature thereon, authorizes the Owner to obtain reference information concerning the Offeror and releases the party providing such information and the Owner from any and all liability to the Offeror as a result of such reference information so provided.

The Owner reserves the right to reject the Bid of any Offeror who does not pass any evaluation to the Owner's satisfaction.

If the Contract is to be awarded, it will be awarded to the Offeror who, by evaluation, the Owner determines will best meet the Owner's interests.

The Owner reserves the right to accept or reject the Work contained in any of the Price Bid Schedules or alternates, either in whole or in part.

**2.50. Award of Contract:** Unless otherwise indicated, a single award will be made for all the bid items in an individual bid schedule. In the event that the Work is contained in more than one Bid Schedule, the City may award Schedules individually or in combination. In the case of two Bid Schedules which are alternative to each other, only one of such alternative Schedules will be awarded. Within forty-five (45) Calendar Days of Bid Opening, the City will issue a Notice of Award to the Successful Offeror which will be accompanied by a Contract electronically submitted via DocuSign for digital signature. Within ten (10) Calendar Days thereafter, the Successful Offeror shall sign and deliver the digitally executed Contract via DocuSign. Performance Bond, Payment Bond, and Certificates of Insurance shall be submitted to the City within ten (10) days of Contract execution. No Contract shall exist between the Successful Offeror and the City, and the Successful Offeror shall have no rights at law or in equity until the Contract has been duly executed by the City.

The Successful Offeror's failure to sign and submit a Contract and other documents set forth in this Paragraph within the prescribed time shall be just cause of annulment of the award, and forfeiture of the Bid Guaranty. The award of Contract may then be made to the next qualified Offeror in the same manner as previously prescribed.

**2.51. Ownership:** All plans, prints, designs, concepts, etc., shall become the property of the Owner.

**2.52. Oral Statements:** No oral statement of any person shall modify or otherwise affect the terms, conditions, or specifications stated in this document and/or resulting agreement. All modifications to this request and any agreement must be made in writing by the Owner.

**2.53. Patents/Copyrights:** The Contractor agrees to protect the Owner from any claims involving infringements of patents and/or copyrights. In no event shall the Owner be liable to the Contractor for any claims, damages, awards and/or costs of defense arising on the grounds of patent(s)/copyright(s) infringement. Patent/copyright infringement shall null and void any agreement resulting from response to this Invitation For Bid.

**2.54. Remedies:** The Contractor and Owner agree that both parties have all rights, duties, and remedies available as stated in the Uniform Commercial Code.

**2.55. Governing Law:** Any agreement as a result of responding to this Invitation For Bid shall be deemed to have been made in, and shall be construed and interpreted in accordance with, the laws of the City of Grand Junction, Mesa County, Colorado.

**2.56. Expenses:** Expenses incurred in preparation, submission, and presentation of a response to this Invitation For Bid are the responsibility of the Offeror and cannot be charged to the Owner.

**2.57. Sovereign Immunity:** The Owner specifically reserves its right to sovereign immunity pursuant to Colorado law as a defense to any action arising out of or under a Contract.

**2.58. Public Funds/Non-Appropriation of Funds:** Funds for payment have been provided through the Owner's budget approved by the City Council for the stated fiscal year only. State of Colorado prohibits the obligation and expenditure of public funds beyond the

fiscal year for which a budget has been approved. Therefore, anticipated orders or other obligations that may arise past the end of the stated Owner's fiscal year shall be subject to budget approval. The Contract, if any, will be subject to and must contain a non-appropriation of funds clause/limitation on multi-year fiscal obligations as required by Article X, Section 20. of the Colorado Constitution, and other applicable law(s).

**2.59. Cooperative Purchasing:** Purchases as a result of this solicitation are primarily for the Owner. Other governmental entities may be extended the opportunity to utilize the resultant Contract award with the agreement of the successful provider and the participating agencies. All participating entities will be required to abide by the specifications, terms, conditions, and pricings established in this Bid. The quantities furnished in this bid document are for only the Owner. It does not include quantities for any other jurisdiction. The City will be responsible only for the award for its jurisdiction. Other participating entities will place its own awards on its respective Purchase Orders through its purchasing office or use its purchasing card for purchase/payment as authorized or agreed upon between the provider and the individual entity. The Owner accepts no liability for payment of orders placed by other participating jurisdictions that choose to "piggy-back" on Owner's solicitation. Orders placed by participating jurisdictions under the terms of this solicitation will indicate its specific delivery and invoicing instructions.

**2.60. Keep Jobs in Colorado Act:** Contractor shall be responsible for ensuring compliance with Article 17 of Title 8, Colorado Revised Statutes (C.R.S.) requiring 80% Colorado labor to be employed on public works. Contractor shall, upon reasonable notice provided by the Owner, permit the Owner to inspect documentation of identification and residency required by C.R.S. §8-17-101(2)(a). If Contractor claims it is entitled to a waiver pursuant to C.R.S. §8-17-101(1), Contractor shall state that there is insufficient Colorado labor to perform the Work such that compliance with Article 17 would create an undue burden that would substantially prevent a project from proceeding to completion and shall include evidence demonstrating the insufficiency and undue burden in its response.

Unless expressly granted a waiver by the Owner pursuant to C.R.S. §8-17-101(1), Contractor shall be responsible for ensuring compliance with Article 17 of Title 8, C.R.S. requiring 80% Colorado labor to be employed on public works. Contractor shall, upon reasonable notice provided by the Owner, permit the Owner to inspect documentation of identification and residency required by C.R.S. §8-17-101(2)(a).

**2.60.1.** "Public Project" is defined as:

- (a) any construction, alteration, repair, demolition, or improvement of any land, building, structure, facility, road, highway, bridge, or other public improvement suitable for and intended for use in the promotion of the public health, welfare, or safety and any maintenance programs for the upkeep of such projects;
- (b) for which appropriate or expenditure of moneys may be reasonably expected to be \$500,000.00 or more in the aggregate for any fiscal year;
- (c) except any project that receives federal moneys.



### **3. Statement of Work**

- 3.1. GENERAL:** The City of Grand Junction is soliciting competitive bids from qualified and interested Contractors for all labor, equipment, materials, and supplies required for the purchase and installation of twenty (20) safety bollards. Nine (9) bollards will be installed at City Hall and eleven (11) will be installed at GJPD. All dimensions and Scope of Work should be verified by Contractors prior to submission of bids.

NOTE: The descriptions of the pay items listed in the Price Bid Schedule for this Project may not agree with those listed in the Standard Specifications. Payment for all Work performed, as required in the Contract Documents will be in accordance with the items and units listed in the Price Bid Schedule.

The performance of the Work for this Project shall conform to the General Contract Conditions presented in the City of Grand Junction's Standard Contract Documents for Capital Improvements Construction, revised July 2010, except as specifically modified or supplemented herein or on the Construction Drawings.

- 3.2. PROJECT DESCRIPTION:** The Project generally consists of the installation of eight (8) fixed non-removable safety bollards and twelve (12) removable safety bollards. All removable bollards must have the ability to be locked in place. The installation of fixed and non-fixed bollards should be **complete and in place**. This Work shall include but may not be limited to the removal of concrete, excavation, placement and compaction of base course, rebar, concrete sidewalk, and any other appurtenances for the completion of the Project. All dimensions and Scope of Work shall be verified by Contractors prior to submission of bids.

GJPD Location – Eight (8) Fixed non-removable bollards, three (3) removable bollards with the ability to be locked in place. Bollard must be SS polished finish including the embedment sleeve. Both fixed and removable bollards shall be **complete and in place**.

City Hall Location – Nine (9) removable carbon steel bollards with the ability to be locked in place. Contractor must provide powder coating color options for approval. Alternatively, may opt to keep bollards SS at this location. Embedment sleeve must be SS. Installation of removable bollards must be **complete and in place**.

- 3.3. SPECIAL CONDITIONS & PROVISIONS:**

**3.3.1. Non-Mandatory Pre-Bid Site Walk Down Meeting:** Interested Contractors are strongly encouraged to attend a site visit inclusive of walking down each identified installation location for this Project. The purpose of this site visit meeting will be to inspect and clarify the contents of this Invitation for Bid (IFB). **The site visit will take place on May 4, 2023, at 9:00am starting at City Hall, located at 250 N 5<sup>th</sup> St, Grand Junction, CO and continue to Grand Junction Police Department (GJPD).** *Nothing stated during this site visit meeting will modify the solicitation. Only information provided in an addendum can modify the IFB.*

**3.3.2. QUESTIONS REGARDING SOLICIATION PROCESS/SCOPE OF WORK:**

Kathleen Franklin, Senior Buyer  
City of Grand Junction  
[kathleenf@gjcity.org](mailto:kathleenf@gjcity.org)

- 3.3.3. Project Manager:** The Project Manager for the Project is Kyle Coltrinari, General Services Manager, who can be reached at (970) 254-3889 or email [kylec@gjcity.org](mailto:kylec@gjcity.org). During Construction, all notices, letters, submittals, and other communications directed to the City shall be addressed and mailed or delivered to:

City of Grand Junction  
General Services Department  
Attn: Kyle Coltrinari  
333 West Ave, Unit C  
Grand Junction, CO 81501

- 3.3.4. Contract Administrator:** The Contract Administrator for the Project is Duane Hoff Jr., Contract Administrator, who can be reached at (970)244-1545. During Construction, Contract related inquiries, issues, and other communications shall be directed to:

Duane Hoff Jr., Contract Administrator  
[duaneh@gjcity.org](mailto:duaneh@gjcity.org)

- 3.3.5. Affirmative Action:** The Contractor is not required to submit a written Affirmative Action Program for the Project.

- 3.3.6. Pricing:** Pricing shall be all inclusive to include but not be limited to: all labor, equipment, supplies, materials, freight (F.O.B. Destination – Freight Pre-paid and Allowed to each site), travel, mobilization costs, fuel, set-up and take down costs, and full-time inspection costs, and all other costs related to the successful completion of the project.

The Owner shall not pay nor be liable for any other additional costs including but not limited to: taxes, shipping charges, insurance, interest, penalties, termination payments, attorney fees, liquidated damages, etc.

- 3.3.7. Freight/Shipping:** All freight/shipping shall be F.O.B. Destination – Freight Pre-Paid and Allowed to the project site(s), Grand Junction, CO.

Contractor must meet all federal, state, and local rules, regulations, and requirements for providing such services.

- 3.3.8. Contract:** A binding Contract shall consist of: (1) the IFB and any amendments thereto, (2) Additional Documents as stated in Section 1.10, (3) the Offeror's response (bid) to the IFB, (4) clarification of the bid, if any, and (5) the City's Purchasing Department's acceptance of the bid by "Notice of Award" or by

“Purchase Order”. All Exhibits and Attachments included In the IFB shall be incorporated into the Contract by reference.

- A. The Contract expresses the complete agreement of the parties and, performance shall be governed solely by the specifications and requirements contained therein.
- B. Any change to the Contract, whether by modification and/or supplementation, must be accomplished by a formal Contract amendment signed and approved by and between the duly authorized representative of the Offeror and the City Purchasing Division or by a modified Purchase Order prior to the effective date of such modification. The Offeror expressly and explicitly understands and agrees that no other method and/or no other document, including acts and oral communications by or from any person, shall be used or construed as an amendment or modification to the Contract.

**3.3.9. Time of Completion:** The scheduled time of Completion for the Project is **75 Calendar Days** from the starting date specified in the Notice to Proceed.

Completion is achieved when site cleanup and all punch list items (resulting from the final inspection) have been completed. Completion shall have the meaning set forth in Article I, Section 3 (Definitions and Terms) of the General Contract Conditions.

**3.3.10. Working Days and Hours:** The working days and hours shall be as stated in the General Contract Conditions or as mutually agreed upon in the preconstruction meeting with the following exception:

All Work shall be performed between the hours of 7:00 AM to 5:00 PM.

**3.3.11. Licenses and Permits:** Contractor is responsible for obtaining all necessary licenses and permits required for Construction, at Contractors expense. See Section 2.12. Contractor shall supply to Owner all copies of finalized permits.

**3.3.12. Permits:** The following permits are required for the Project and will be obtained by the City at no cost to the Contractor:

- None

The following permits are required for the Project and shall be obtained and paid for by the Contractor, with the costs included in the total bid price for the Project:

- None

**3.3.13. Project Sign:** Project signs, if any, will be furnished and installed by the City.

**3.3.14. Authorized Representatives of the City:** Those authorized to represent the City shall include Purchasing Agent, Engineers, and Inspectors employed by the City, only.

- 3.3.15. Stockpiling Materials and Equipment:** All stockpiling/storage shall be in accordance with General Contract Condition Section 51.
- 3.3.16. Traffic Control:** The Contractor shall provide and maintain traffic control in accordance with the approved Traffic Control Plan and the Manual on Uniform Traffic Control Devices. A Traffic Control Plan shall be prepared by the Contractor and reviewed by the City two days prior to the pre-construction meeting.
- 3.3.17. Clean-Up:** The Contractor is responsible for cleaning up all loose materials that have been deposited or swept into gutters, and onto sidewalks and driveways as a result of sidewalk operations. The costs for all clean-up Work shall be considered incidental and will not be paid for separately.
- 3.3.18. Quality Control Testing:** Contractor shall perform quality control testing specified in the Project Manual. The City will perform all other necessary Quality Assurance testing specified in the Project Manual.
- 3.3.19. Schedule of Submittals:** Contractor shall deliver these submittals at least two days prior to the pre-construction meeting:
- Project Schedule
  - Warranty & Manufacture Specification Sheet for Bollards
  - Warranty & Manufacturing Specification Sheets for Embedment Sleeves
  - Concrete Mix Design
  - Class 6 Aggregate Base Course Design
  - Concrete Washout Facility Plan for Both Locations
  - Traffic Control Plan
- 3.3.20. Uranium Mill Tailings:** It is anticipated that radioactive mill tailings will not be encountered on this Project.
- 3.3.21. Fugitive Petroleum or Other Contamination:** It is anticipated that soil contamination from fugitive petroleum or other contaminants will not be encountered with the Project.
- 3.3.22. Excess Material:** All excess materials shall be disposed in accordance with General Contract Condition Section 50.
- 3.3.23. Existing Utilities and Structures:** Utilities were not potholed during development of this project. It is the responsibility of the Contractor to pothole/locate and protect all structures and utilities in accordance with General Contract Condition Section 37.
- 3.3.24. Incidental Items:** Any item of Work not specifically identified or paid for directly, but which is necessary for the satisfactory completion of any paid items of Work, will be considered as incidental to those items, and will be included in the cost of those items.

**3.3.25. Estimated Quantities:** The quantities indicated in this Invitation for Bid are estimates which pertain to the total aggregate quantities which may be ordered throughout the stated Contract period. Variation of quantities may increase or decrease. The estimates do not indicate single order amounts unless otherwise stated. The Owner makes no guarantees about single order quantities or total aggregate order quantities.

**3.3.26. Minimum Order Quantiles:** The Offeror will not establish a minimum order quantity for items under this contract.

**3.3.27. Work to be Performed by the City (Prior to Construction):**

- None

**3.3.28. Existing Concrete Sidewalks, Pans, Fillets, Curbs and Gutters:** The existing sidewalks, pans, fillets, curb, and gutter are in good serviceable condition. In most instances the installation of new sidewalk and pavement will be adjacent to existing concrete. The Contractor will need to protect all concrete adjacent to construction. If the concrete is damaged during construction the Contractor will be responsible for its replacement at no cost to the City. The Contractor, the City Project Inspector, and/or the City Project Manager will walk and record any concrete that is deemed to be damaged before construction has started.

**3.3.29. ACI Concrete and Flatwork Finisher and Technician:** Hand finishing concrete will be permitted only when performed under the direct supervision of a craftsman holding the following certificate: ACI Concrete Flatwork Finisher and Technician (ACICFFT) or other Flatwork Finisher certification program approved by the City Engineering Manager.

**3.4. SCOPE OF WORK:** Contractor is responsible for purchase and installation of twenty (20) security bollards. There will be eight (8) fixed non-removable safety bollards and twelve (12) removable safety bollards. All removable bollards must have the ability to be locked in place. The installation of fixed and non-fixed bollards should be **complete and in place**. This Work shall include but may not be limited to the removal of concrete, excavation, placement and compaction of base course, rebar, concrete sidewalk, and any other appurtenances for the completion of the Project. All dimensions and Scope of Work shall be verified by Contractors prior to submission of bids.

GJPD Location – Eight (8) fixed non-removable bollards, three (3) removable bollards with the ability to be locked in place. Bollard must be SS polished finish including the embedment sleeve. Both fixed and removable bollards shall be **complete and in place**.

City Hall Location – Nine (9) removable carbon steel bollards with the ability to be locked in place. Contractor must provide powder coating color options for approval. Alternatively, may opt to keep bollards SS at this location. Embedment sleeve must be SS. Installation of removable bollards must be **complete and in place**.

**3.4.1.** All concrete and asphalt removal required for installation will be considered incidental and will not be measured or paid for separately.

**3.4.2. Concrete Washout Structure:** Water for clean-up of equipment used in the mixing or distribution of concrete shall not be discharged to any storm water facilities, drain ways, or deposited into any open fields. The wastewater used shall either be wasted on an open excavation area or in an onsite detention facility for future disposal.

**3.5. SPECIFICATIONS:** The Safety Bollards specifications are as follows:

**3.5.1.** Must be a minimum of 36” in height.

**3.5.2.** Must be a minimum of 6” in diameter.

**3.5.3.** Must be able to stop a 5,000 lbs. vehicle traveling 30 mph.

**3.6. MANUFACTURER SPECIFICATION SHEET:** Offeror shall submit with its response the security bollard and embedment sleeve manufacturer specification sheets and delivery lead time.

**3.7. ADDITIONAL QUANTITY OPTION:** The Owner reserves the right to increase quantity of security bollard(s) and/or add location by Contract Change determined by unit price(s) specified in Price Bid Schedule.

**3.8. ATTACHMENTS:**

[A: City Hall Bollard Locations](#)

[B: GJPD Bollard Placement](#)

**3.9. Contractor Bid Documents:** For Contractor’s convenience, the following is a list of forms/items to be submitted with the Contractor’s bid response. However, should a form/item not be listed in this section, but required in the solicitation documents, it is the Contractor’s responsibility to ensure all forms/items are submitted.

- **Contractor’s Bid Form**
- **Price Bid Schedule Form**
- **Manufacturer Specification Sheets, Warranty Information and Delivery Lead Time**

**3.10. IFB TENTATIVE TIME SCHEDULE:**

Invitation For Bids available	April 26, 2023
Non-Mandatory Pre-Bid Site Walk Down Meeting	May 4, 2023
Inquiry deadline, no questions after this date	May 11, 2023
Addendum Posted	May 12, 2023
Submittal deadline for bids	May 23, 2023
City Council Approval <i>(if required)</i>	June 7, 2023
Notice of Award & Contract execution	June 9, 2023
Bonding & Insurance Cert due	June 20, 2023
Preconstruction meeting	To Be Determined
Work begins no later than	Receipt of Notice to Proceed
Final Completion	75 Calendar Days from start date of Notice to Proceed

**Holidays:**

**Memorial Day  
Juneteenth  
Independence Day  
Labor Day**

**May 29, 2023  
June 19, 2023  
July 4, 2023  
September 4, 2023**

## 4. Contractor's Bid Form

**Bid Date:** \_\_\_\_\_

**Project:** IFB-5244-23-KF "Safety Bollard Purchase and Installation Project"

**Bidding Company:** \_\_\_\_\_

**Name of Authorized Agent:** \_\_\_\_\_

**Email:** \_\_\_\_\_

**Telephone:** \_\_\_\_\_ **Address:** \_\_\_\_\_

**City:** \_\_\_\_\_ **State:** \_\_\_\_\_ **Zip:** \_\_\_\_\_

The undersigned Offeror, in compliance with the Invitation for Bids, having examined the Instruction to Offerors, General Contract Conditions, Statement of Work, Specifications, and any and all Addenda thereto, having investigated the location of, and conditions affecting the proposed Work, hereby proposes to furnish all labor, materials and supplies, and to perform all Work for the Project in accordance with Contract Documents, within the time set forth and at the prices stated below. These prices are to cover all expenses incurred in performing the Work required under the Contract Documents, of which this Contractor's Bid Form is a part.

The undersigned Contractor does hereby declare and stipulate that this offer is made in good faith without collusion or connection to any person(s) providing an offer for the same Work, and that it is made in pursuance of, and subject to, all terms and conditions of the Instructions to Offerors, the Specifications, and all other Solicitation Documents, all of which have been examined by the undersigned.

The Contractor also agrees that if awarded the Contract, to provide insurance certificates within ten (10) working days of the date of Notification of Award. Submittal of this offer will be taken by the Owner as a binding covenant that the Contractor will be prepared to complete the project in its entirety.

The Owner reserves the right to make the award on the basis of the offer deemed most favorable, to waive any formalities or technicalities and to reject any or all offers. It is further agreed that this offer may not be withdrawn for a period of sixty (60) calendar days after closing time. Submission of clarifications and revised offers automatically establish a new thirty-day (30) period.

Prices in the bid proposal have not knowingly been disclosed with another provider and will not be prior to award.

- Prices in this bid proposal have been arrived at independently, without consultation, communication, or agreement for the purpose of restricting competition.
- No attempt has been made nor will be to induce any other person or firm to submit a bid proposal for the purpose of restricting competition.
- The individual signing this bid proposal certifies it is a legal agent of the offeror, authorized to represent the offeror and is legally responsible for the offer with regard to supporting documentation and prices provided.
- Direct purchases by the City of Grand Junction are tax exempt from Colorado Sales or Use Tax. Tax exempt No. 98-03544. The undersigned certifies that no Federal, State, County or Municipal tax will be added to the above quoted prices.
- City of Grand Junction payment terms shall be Net 30 days.
- Prompt payment discount of \_\_\_\_\_ percent of the net dollar will be offered to the Owner if the invoice is paid within \_\_\_\_\_ days after the receipt of the invoice. The Owner reserves the right to take into account any such discounts when determining the bid award that are no less than Net 10 days.

RECEIPT OF ADDENDA: the undersigned Contractor acknowledges receipt of Addenda to the Solicitation, Specifications, and other Contract Documents.

State number of Addenda received: \_\_\_\_\_

It is the responsibility of the Offeror to ensure all Addenda have been received and acknowledged.

*By signing below, the Undersigned agree to comply with all terms and conditions contained herein.*

**Company:** \_\_\_\_\_

**Authorized Signature:** \_\_\_\_\_

**Title:** \_\_\_\_\_



The undersigned Offeror proposes to subcontract the following portion of Work:

<u>Name &amp; address of Sub-Contractor</u>	<u>Description of Work to be performed</u>	<u>% of Contract</u>
_____	_____	_____
_____	_____	_____
_____	_____	_____

The undersigned Offeror acknowledges the right of the City to reject any and all Bids submitted and to waive informalities and irregularities therein in the City's sole discretion.

By submission of the Bid, each Offeror certifies, and in the case of a joint Bid each party thereto certifies as to its own organization, that this Bid has been arrived at independently, without collusion, consultation, communication, or agreement as to any matter relating to this Bid with any other Offeror or with any competitor.

**PRICE BID SCHEDULE: IFB-5244-23-KF, Safety Bollard Purchase and Installation Project**

Item No.	Description	Quantity	Unit Price	Total Price
1)	Total price per bollard to include: labor, materials, parts, freight, etc. to purchase and install eight (8) <i>non-removable SS security bollards with SS embedment sleeve</i> . This Work will include but may not be limited to the removal of concrete, excavation, placement and compaction of base course, rebar, concrete sidewalk, and any other appurtenances for the completion of the Project.	8	\$ _____	\$ _____
<p><b>1) Line-Item Total Price written</b> _____ dollars.</p> <p>Provide manufacture specification sheet for bollard &amp; embedment sleeve: _____.</p> <p>Provide product delivery lead time for bollard &amp; embedment sleeve: _____.</p> <p>Warranty (please specify warranty provided) for bollard &amp; embedment sleeve: _____.</p>				
2)	Total price per bollard to include: labor, materials, parts, freight, etc. to purchase and install <i>three (3) removable SS security bollards with ability to be locked in place with SS embedment sleeve</i> . This Work will include but may not be limited to the removal of concrete, excavation, placement and compaction of base course, rebar, concrete sidewalk, and any other appurtenances for the completion of the Project.	3	\$ _____	\$ _____
<p><b>2) Line-Item Total Price written</b> _____ dollars.</p> <p>Provide manufacture specification sheet for bollard &amp; embedment sleeve: _____.</p> <p>Provide product delivery lead time for bollard &amp; embedment sleeve: _____.</p> <p>Warranty (please specify warranty provided) for bollard &amp; embedment sleeve: _____.</p>				
3)	Total price per bollard to include: labor, materials, parts, freight, etc. to purchase and install <i>nine (9) removable carbon steel security bollards with ability to be locked in place. Powder-coated color options for approval by City and SS embedment sleeve</i> . This Work will include but may not be limited to the removal of concrete, excavation, placement and compaction of base course, rebar,	9	\$ _____	\$ _____

	concrete sidewalk, and any other appurtenances for the completion of the Project.			
--	---	--	--	--

**3) Line-Item Total Price written** \_\_\_\_\_ dollars.

Provide manufacture specification sheet for bollard & embedment sleeve: \_\_\_\_\_.

Provide product delivery lead time for bollard & embedment sleeve: \_\_\_\_\_.

Warranty (please specify warranty provided) for bollard & embedment sleeve: \_\_\_\_\_.

Total Project Bid Amount \$ \_\_\_\_\_

Total Project Bid Price **written** \_\_\_\_\_ dollars.

*By signing below, the Undersigned agree to comply with all terms and conditions contained herein.*

**Company:** \_\_\_\_\_

**Authorized Signature:** \_\_\_\_\_

**Title:** \_\_\_\_\_



All Bollards At City Hall Are Removable

ROODE AVE



Yellow indicate removable bollards, Red indicate Fixed Bollards  
Bollards to be placed + or - 5.9' apart

5.9 Feet



Purchasing Division

## **ADDENDUM NO. 1**

**DATE:** May 8, 2023  
**FROM:** City of Grand Junction Purchasing Division  
**TO:** All Offerors  
**RE:** Safety Bollard Purchase and Installation Project IFB-5244-23-KF

Offerors responding to the above referenced solicitation are hereby instructed that the requirements have been clarified, modified, superseded, and supplemented as to this date as hereinafter described.

Please make note of the following clarifications:

1. Attachment [A: City Hall Bollard Location](#) is updated to include location #.
2. **Q:** Will the installation of security bollard require the entire cement stone to be removed?  
**A:** All concrete removed during installation must be removed in its entirety back to the nearest joint.
3. **Q:** Will cement removal in front of main entrance off Rood Ave require any of the colored exposed aggregate stones to be removed? Can they be replaced with standard grey cement?  
**A:** City Hall Location #2, bollards to be placed in "existing grey" concrete. Bollards not to be placed in colored exposed aggregate concrete.
4. **Q:** City Hall main entrance off Rood Ave narrow walkway closest to the building, is alternating colored exposed aggregate and standard grey cement. If bollard installation requires the colored exposed aggregate stone to be removed, is it ok to replace with standard grey cement?  
**A:** City Hall location #3, if bollard installation disrupts the colored exposed aggregate concrete" it is ok to be replaced with standard grey concrete.
5. **Q:** City Hall West entrance by auditorium, off N 5<sup>th</sup> St – two of the four cement stones are colored exposed aggregate stones. Is it ok to replace with standard grey cement?  
**A:** City Hall location #4, ok to be replaced with standard grey concrete.
6. **Q:** City Hall North entrance off White Ave has a total of six (6) stones: two (2) narrow smaller stones and four (4) larger square. Removal of two (2) centered will be required for bollard installation. There is damage to two (2) closer to the building. How many cement stones does the City want removed at this location?  
**A:** City Hall location #5, all concrete between the sidewalk and the door to be removed and replaced with standard grey concrete.

7. **Q:** What is expected for traffic control at City Hall?  
**A:** During the installation of the bollards located at City Hall, traffic will need to flow on Rood Ave, N 5<sup>th</sup> St, and White Ave.
8. **Q:** Will City restrict access to meter parking during construction? Contractor skid loader and other equipment will be required near work locations.  
**A:** The City will assist in providing access to parking spaces adjacent to work zone for material removal and delivery.
9. **Q:** Will the City restrict access to the parking lot in front of GJPD during construction? Main lobby access?  
**A:** Given proper notice (two (2) days), the City will be able to accommodate construction needs during bollard installation at GJPD location.
10. **Q:** What is the cement color finish at GJPD?  
**A:** All concrete removed at GJPD must be replaced with like color and finish.
11. **Q:** Will the City of GJ require an external (less expensive) or internal (higher cost) locking mechanism on removeable bollards? Some removable bollards have an external latch and require individual pad lock(s), and some offer internal locking device like a Helix Locking with T Allen key.  
**A:** The City will require an internal locking mechanism on all removable bollards.
12. **Q:** Has the City taken into account the security and safety access through the landscaping area at GJPD, between the single bollard and the other bollards?  
**A:** Yes, the City has taken into consideration this area at GJPD.

The original solicitation for the project noted above is amended as noted.

All other conditions of subject remain the same.

Respectfully,



Kathleen Franklin, Senior Buyer  
City of Grand Junction, Colorado







**Purchasing Division**

**ADDENDUM NO. 2**

**DATE: May 12, 2023**  
**FROM: City of Grand Junction Purchasing Division**  
**TO: All Offerors**  
**RE: Safety Bollard Purchase and Installation Project IFB-5244-23-KF**

Offerors responding to the above referenced solicitation are hereby instructed that the requirements have been clarified, modified, superseded, and supplemented as to this date as hereinafter described.

Please make note of the following clarifications:

1. **Q:** Will the Notice to Proceed start after the bollards are purchased and in Contractor's possession?  
**A:** No. The Notice to Proceed is issued after the Contract is signed, and bonds & insurance is received. Time of Completion can be adjusted with consideration on delivery lead times.
2. **Q:** Can the Contractor invoice and receive funding for bollard materials prior to ordering the bollards?  
**A:** Prepayment will not be allowed for this project. Unless otherwise provided in the Solicitation, monthly partial payments shall be made as the Work progresses. Applications for partial and Final Payment shall be prepared by the Contractor and approved by the Owner in accordance with the Solicitation.
3. **Q:** What is the reinforcement requirement in the concrete?  
**A:** The specification for concrete reinforcement and footer design is to be provided by the Contractor, in accordance with bollard manufacturer requirements.

The original solicitation for the project noted above is amended as noted.

All other conditions of subject remain the same.

Respectfully,

A handwritten signature in blue ink, appearing to read "K. Franklin".

Kathleen Franklin, Senior Buyer  
City of Grand Junction, Colorado

## 4. Contractor's Bid Form

**Bid Date:** May 23, 2023

**Project:** IFB-5244-23-KF "Safety Bollard Purchase and Installation Project"

**Bidding Company:** Merritt & Associates GC Inc.

**Name of Authorized Agent:** Merritt Sixbey

**Email:** Merritt@MAGCinc.com

**Telephone:** 970-241-5164 **Address:** 2108 Hwy 6 & 50

**City:** Grand Junction **State:** CO **Zip:** 81505

The undersigned Offeror, in compliance with the Invitation for Bids, having examined the Instruction to Offerors, General Contract Conditions, Statement of Work, Specifications, and any and all Addenda thereto, having investigated the location of, and conditions affecting the proposed Work, hereby proposes to furnish all labor, materials and supplies, and to perform all Work for the Project in accordance with Contract Documents, within the time set forth and at the prices stated below. These prices are to cover all expenses incurred in performing the Work required under the Contract Documents, of which this Contractor's Bid Form is a part.

The undersigned Contractor does hereby declare and stipulate that this offer is made in good faith without collusion or connection to any person(s) providing an offer for the same Work, and that it is made in pursuance of, and subject to, all terms and conditions of the Instructions to Offerors, the Specifications, and all other Solicitation Documents, all of which have been examined by the undersigned.

The Contractor also agrees that if awarded the Contract, to provide insurance certificates within ten (10) working days of the date of Notification of Award. Submittal of this offer will be taken by the Owner as a binding covenant that the Contractor will be prepared to complete the project in its entirety.

The Owner reserves the right to make the award on the basis of the offer deemed most favorable, to waive any formalities or technicalities and to reject any or all offers. It is further agreed that this offer may not be withdrawn for a period of sixty (60) calendar days after closing time. Submission of clarifications and revised offers automatically establish a new thirty-day (30) period.

Prices in the bid proposal have not knowingly been disclosed with another provider and will not be prior to award.

- Prices in this bid proposal have been arrived at independently, without consultation, communication, or agreement for the purpose of restricting competition.
- No attempt has been made nor will be to induce any other person or firm to submit a bid proposal for the purpose of restricting competition.
- The individual signing this bid proposal certifies it is a legal agent of the offeror, authorized to represent the offeror and is legally responsible for the offer with regard to supporting documentation and prices provided.
- Direct purchases by the City of Grand Junction are tax exempt from Colorado Sales or Use Tax. Tax exempt No. 98-03544. The undersigned certifies that no Federal, State, County or Municipal tax will be added to the above quoted prices.
- City of Grand Junction payment terms shall be Net 30 days.
- Prompt payment discount of 0 percent of the net dollar will be offered to the Owner if the invoice is paid within 0 days after the receipt of the invoice. The Owner reserves the right to take into account any such discounts when determining the bid award that are no less than Net 10 days.

RECEIPT OF ADDENDA: the undersigned Contractor acknowledges receipt of Addenda to the Solicitation, Specifications, and other Contract Documents.

State number of Addenda received: 2

It is the responsibility of the Offeror to ensure all Addenda have been received and acknowledged.

By signing below, the Undersigned agree to comply with all terms and conditions contained herein.

**Company:** Merritt & Associates GC Inc.

**Authorized Signature** 

**Title:** President

The undersigned Offeror proposes to subcontract the following portion of Work:

<u>Name &amp; address of Sub-Contractor</u>	<u>Description of Work to be performed</u>	<u>% of Contract</u>
<u>Shabuoy Construction Services LLC</u>	<u>Finishing Concrete</u>	<u>10%</u>
<u> </u>	<u> </u>	<u> </u>
<u> </u>	<u> </u>	<u> </u>

The undersigned Offeror acknowledges the right of the City to reject any and all Bids submitted and to waive informalities and irregularities therein in the City's sole discretion.

By submission of the Bid, each Offeror certifies, and in the case of a joint Bid each party thereto certifies as to its own organization, that this Bid has been arrived at independently, without collusion, consultation, communication, or agreement as to any matter relating to this Bid with any other Offeror or with any competitor.

**PRICE BID SCHEDULE: IFB-5244-23-KF, Safety Bollard Purchase and Installation Project**

Item No.	Description	Quantity	Unit Price	Total Price
1)	Total price per bollard to include: labor, materials, parts, freight, etc. to purchase and install eight (8) <i>non-removable SS security bollards with SS embedment sleeve</i> . This Work will include but may not be limited to the removal of concrete, excavation, placement and compaction of base course, rebar, concrete sidewalk, and any other appurtenances for the completion of the Project.	8	\$ <u>7,168.26</u>	\$ <u>57,346.08</u>
<p><b>1) Line-Item Total Price written</b> <u>Fifty-seven thousand, three hundred forty-six and 08/100</u> dollars.</p> <p>Provide manufacture specification sheet for bollard &amp; embedment sleeve: <u>See attached</u>.</p> <p>Provide product delivery lead time for bollard &amp; embedment sleeve: <u>5-7 weeks, see attached</u>.</p> <p>Warranty (please specify warranty provided) for bollard &amp; embedment sleeve: <u>1 year, see attached</u>.</p>				
2)	Total price per bollard to include: labor, materials, parts, freight, etc. to purchase and install <i>three (3) removable SS security bollards with ability to be locked in place with SS embedment sleeve</i> . This Work will include but may not be limited to the removal of concrete, excavation, placement and compaction of base course, rebar, concrete sidewalk, and any other appurtenances for the completion of the Project.	3	\$ <u>8,896.26</u>	\$ <u>26,688.78</u>
<p><b>2) Line-Item Total Price written</b> <u>Twenty-six thousand, six hundred eighty-eight and 78/100</u> dollars.</p> <p>Provide manufacture specification sheet for bollard &amp; embedment sleeve: <u>See attached</u>.</p> <p>Provide product delivery lead time for bollard &amp; embedment sleeve: <u>5-7 weeks, see attached</u>.</p> <p>Warranty (please specify warranty provided) for bollard &amp; embedment sleeve: <u>1 year, see attached</u>.</p>				
3)	Total price per bollard to include: labor, materials, parts, freight, etc. to purchase and install <i>nine (9) removable carbon steel security bollards with ability to be locked in place. Powder-coated color options for approval by City and SS embedment sleeve</i> . This Work will include but may not be limited to the removal of concrete, excavation, placement and compaction of base course, rebar,	9	\$ <u>7,024.26</u>	\$ <u>63,218.34</u>

concrete sidewalk, and any other appurtenances for the completion of the Project.			
---	--	--	--

**3) Line-Item Total Price written** Sixty-three thousand, two hundred-eighteen and 34/100 dollars.

Provide manufacture specification sheet for bollard & embedment sleeve: See attached.

Provide product delivery lead time for bollard & embedment sleeve: 5-7 weeks, see attached.

Warranty (please specify warranty provided) for bollard & embedment sleeve: 1 year, see attached

Total Project Bid Amount \$ 147,253.20

Total Project Bid Price written One hundred forty-seven thousand, two hundred fifty-three & 20/100 dollars.

*By signing below, the Undersigned agree to comply with all terms and conditions contained herein.*

Company: Merritt & Associates GC Inc.

Authorized Signature:  \_\_\_\_\_

Title: President



Liberty Mutual Surety  
Attention: LMS Claims  
P.O. Box 34526  
Seattle, WA 98124  
Phone: 206-473-6210  
Fax: 866-548-6837  
Email: HOSCL@libertymutual.com  
www.LibertyMutualSuretyClaims.com

### The Ohio Casualty Insurance Company BID OR PROPOSAL BOND

KNOW ALL MEN BY THESE PRESENTS, That we, Merrit & Associates G C Inc.

of Grand Junction, Colorado

(hereinafter called the Principal) as Principal, and The Ohio Casualty Insurance Company, with its principal office in the City of Boston, Massachusetts (hereinafter called the Surety), as Surety, are held and firmly bound unto City of Grand Junction

of Grand Junction, Colorado

(hereinafter called the Obligee) in the penal sum of Five Percent of Bid Amount Dollars 5% lawful money of the United States, for the payment of which sum well and truly to be made, we bind ourselves, our heirs, executors, administrators, successors and assigns.

THE CONDITION OF THIS OBLIGATION IS SUCH, that whereas, the Principal has submitted the accompanying bid dated May 23, 2023 for Safety Bollard Purchase and Installation Project

NOW, THEREFORE, if the Obligee shall make any award according to the terms of said bid and the Principal shall enter into a contract with said Obligee in accordance with the terms of said bid and give bond for the faithful performance thereof within the time specified; or if no time is specified within thirty days after the date of said award; or if the Principal shall, in the case of failure so to do, indemnify the Obligee against any loss the Obligee may suffer directly arising by reason of such failure, not exceeding the penalty of this bond, then this obligation shall be null and void; otherwise to remain in full force and virtue.

Signed, sealed and dated: May 22, 2023

Merrit & Associates G C Inc.  
Principal

By: \_\_\_\_\_



The Ohio Casualty Insurance Company

By:   
Darren Coltrinari (Attorney-in-fact)



This Power of Attorney limits the acts of those named herein, and they have no authority to bind the Company except in the manner and to the extent herein stated.

Liberty Mutual Insurance Company
The Ohio Casualty Insurance Company
West American Insurance Company

Certificate No: 8202431-972883

POWER OF ATTORNEY

KNOWN ALL PERSONS BY THESE PRESENTS: That The Ohio Casualty Insurance Company is a corporation duly organized under the laws of the State of New Hampshire, that Liberty Mutual Insurance Company is a corporation duly organized under the laws of the State of Massachusetts, and West American Insurance Company is a corporation duly organized under the laws of the State of Indiana (herein collectively called the "Companies"), pursuant to and by authority herein set forth, does hereby name, constitute and appoint, Darren Coltrinari, Rich J. Englehart, Jerry Hamilton

all of the city of Grand Junction state of Colorado each individually if there be more than one named, its true and lawful attorney-in-fact to make, execute, seal, acknowledge and deliver, for and on its behalf as surety and as its act and deed, any and all undertakings, bonds, recognizances and other surety obligations, in pursuance of these presents and shall be as binding upon the Companies as if they have been duly signed by the president and attested by the secretary of the Companies in their own proper persons.

IN WITNESS WHEREOF, this Power of Attorney has been subscribed by an authorized officer or official of the Companies and the corporate seals of the Companies have been affixed thereto this 25th day of October, 2019.



Liberty Mutual Insurance Company
The Ohio Casualty Insurance Company
West American Insurance Company
By: David M. Carey, Assistant Secretary

Not valid for mortgage, note, loan, letter of credit, currency rate, interest rate or residual value guarantees.

State of PENNSYLVANIA ss
County of MONTGOMERY

On this 25th day of October, 2019 before me personally appeared David M. Carey, who acknowledged himself to be the Assistant Secretary of Liberty Mutual Insurance Company, The Ohio Casualty Company, and West American Insurance Company, and that he, as such, being authorized so to do, execute the foregoing instrument for the purposes therein contained by signing on behalf of the corporations by himself as a duly authorized officer.

IN WITNESS WHEREOF, I have hereunto subscribed my name and affixed my notarial seal at King of Prussia, Pennsylvania, on the day and year first above written.



COMMONWEALTH OF PENNSYLVANIA
Notarial Seal
Teresa Pastella, Notary Public
Upper Merion Twp., Montgomery County
My Commission Expires March 28, 2021
Member, Pennsylvania Association of Notaries

By: Teresa Pastella
Teresa Pastella, Notary Public

This Power of Attorney is made and executed pursuant to and by authority of the following By-laws and Authorizations of The Ohio Casualty Insurance Company, Liberty Mutual Insurance Company, and West American Insurance Company which resolutions are now in full force and effect reading as follows:

ARTICLE IV - OFFICERS: Section 12. Power of Attorney.

Any officer or other official of the Corporation authorized for that purpose in writing by the Chairman or the President, and subject to such limitation as the Chairman or the President may prescribe, shall appoint such attorneys-in-fact, as may be necessary to act in behalf of the Corporation to make, execute, seal, acknowledge and deliver as surety any and all undertakings, bonds, recognizances and other surety obligations. Such attorneys-in-fact, subject to the limitations set forth in their respective powers of attorney, shall have full power to bind the Corporation by their signature and execution of any such instruments and to attach thereto the seal of the Corporation. When so executed, such instruments shall be as binding as if signed by the President and attested to by the Secretary. Any power or authority granted to any representative or attorney-in-fact under the provisions of this article may be revoked at any time by the Board, the Chairman, the President or by the officer or officers granting such power or authority.

ARTICLE XIII - Execution of Contracts: Section 5. Surety Bonds and Undertakings.

Any officer of the Company authorized for that purpose in writing by the chairman or the president, and subject to such limitations as the chairman or the president may prescribe, shall appoint such attorneys-in-fact, as may be necessary to act in behalf of the Company to make, execute, seal, acknowledge and deliver as surety any and all undertakings, bonds, recognizances and other surety obligations. Such attorneys-in-fact subject to the limitations set forth in their respective powers of attorney, shall have full power to bind the Company by their signature and execution of any such instruments and to attach thereto the seal of the Company. When so executed such instruments shall be as binding as if signed by the president and attested by the secretary.

Certificate of Designation - The President of the Company, acting pursuant to the Bylaws of the Company, authorizes David M. Carey, Assistant Secretary to appoint such attorneys-in-fact as may be necessary to act on behalf of the Company to make, execute, seal, acknowledge and deliver as surety any and all undertakings, bonds, recognizances and other surety obligations.

Authorization - By unanimous consent of the Company's Board of Directors, the Company consents that facsimile or mechanically reproduced signature of any assistant secretary of the Company, wherever appearing upon a certified copy of any power of attorney issued by the Company in connection with surety bonds, shall be valid and binding upon the Company with the same force and effect as though manually affixed.

I, Renee C. Llewellyn, the undersigned, Assistant Secretary, The Ohio Casualty Insurance Company, Liberty Mutual Insurance Company, and West American Insurance Company do hereby certify that the original power of attorney of which the foregoing is a full, true and correct copy of the Power of Attorney executed by said Companies, is in full force and effect and has not been revoked.

IN TESTIMONY WHEREOF, I have hereunto set my hand and affixed the seals of said Companies this 22nd day of May, 2023.



By: Renee C. Llewellyn
Renee C. Llewellyn, Assistant Secretary

To confirm the validity of this Power of Attorney call 1-610-832-8240 between 9:00 am and 4:30 pm EST on any business day.

# 1-800-BOLLARDS

**The Bollard Experts**

- SELECT DESIRED MATERIAL:  
(8" NOMINAL SIZE)
  - FCSCCT08080 SCH 80 ASTM A-53 CARBON STEEL
  - FCSCCT08080 SCH 80 SAINLESS STEEL
- SELECT DESIRED STAINLESS STEEL BOLLARD FINISH:
  - POLISHED #4 FINISH
  - AS SPECIFIED \_\_\_\_\_
- SELECT DESIRED CARBON STEEL BOLLARD FINISH:
  - POWDER COAT RAL # \_\_\_\_\_
  - AS SPECIFIED \_\_\_\_\_
- SELECT DESIRED STAINLESS STEEL BOLLARD MATERIAL:
  - TYPE 304
  - TYPE 316
- SELECT DESIRED BOLLARD CAP STYLE:
  - DOME
  - FLAT
  - REVEAL
  - SLOPED

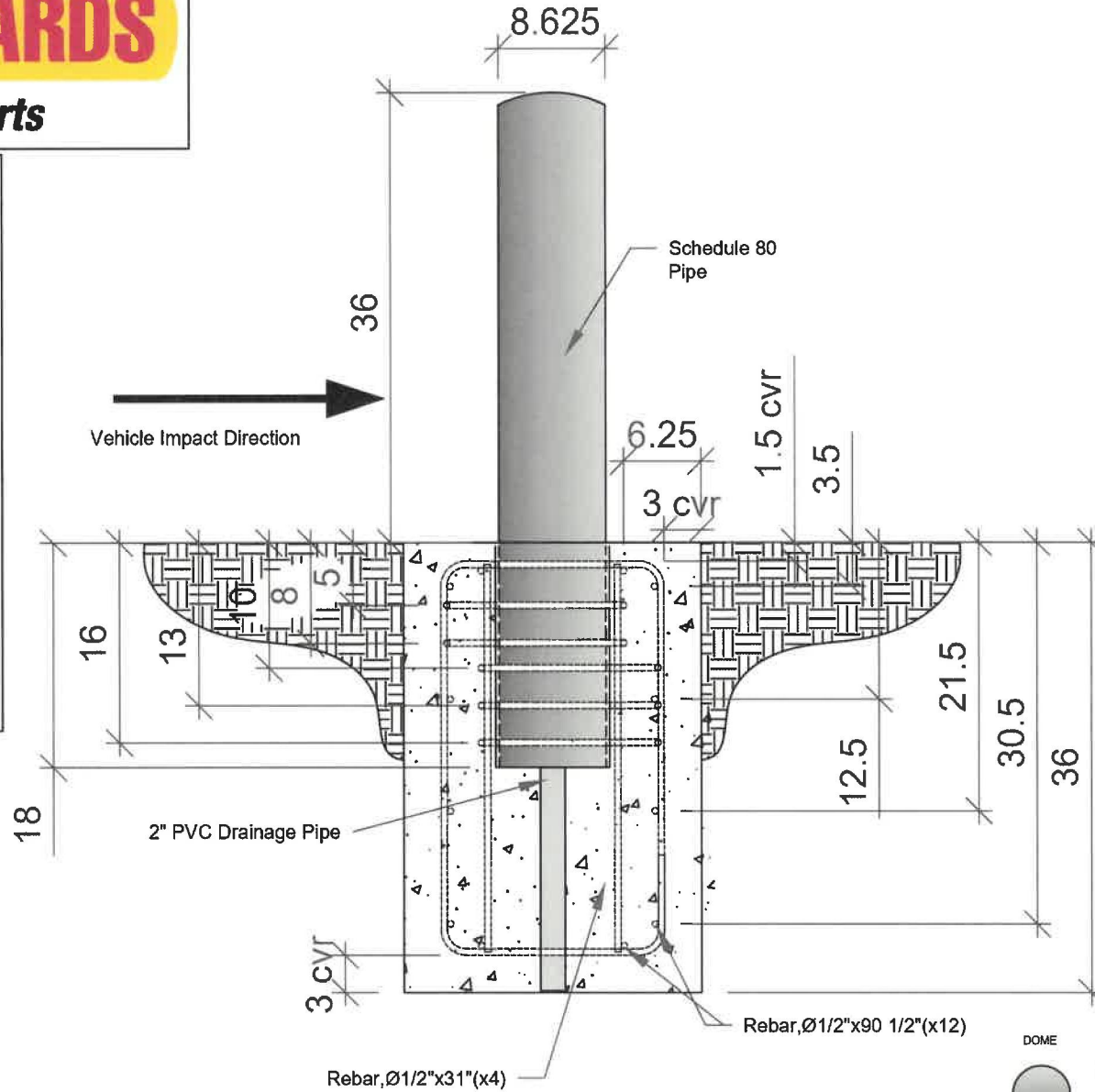

**END VIEW-FOUNDATION**

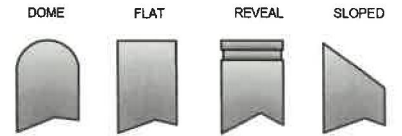

REVISIONS			
LTR	DESCRIPTION	DATE	APPR
COMMENTS			
<b>SPECIFICATIONS</b>			
HEIGHT: 36"			
DIAMETER: 8.625"			
WALL THICKNESS: 0.500"			

**NOTES**  
 1. INSTALLATION TO BE COMPLETED IN ACCORDANCE WITH MANUFACTURER'S SPECIFICATIONS.  
 2. DO NOT SCALE DRAWING.  
 3. THIS COLLUM IS INTENDED FOR USE BY ARCHITECTS, ENGINEERS, CONTRACTORS, OWNERS/AGENTS AND OTHER PROFESSIONALS FOR PLANNING AND INSTALLATION PURPOSES.  
 4. ALL INFORMATION CONTAINED HEREIN WAS OBTAINED AT THE TIME OF DEVELOPMENT BUT MUST BE REVERIFIED AND APPROVED BY THE PRODUCT MANUFACTURER TO BE CONSIDERED ACCURATE.

APPLICATION		SERIES: 8000 FIXED		CASE CODE	SIZE	PACKAGE IDENTIFIER
NEXT REV	USED ON	PRODUCT FAMILY	30 MPH CRASH TESTED	CT8	8	CT80F
		PRODUCT CLASS	STANDARD OR CUSTOMER DEFINED	DRAWN BY	AJA	DESIGNED BY
		PRODUCT LINE	BOLLARD	CHECKED BY		SHEET 1 OF 1
		FIXTURE OR LINE	FIXED	APPROVED BY		RELEASE DATE 1-3-2023
		1-800-BOLLARDS, Inc.		TITLE		
		30 Highway Suite 400		BOLLARD, CT FIXED		
		Irvine, CA 92618				
		PHONE: 1-800-BOLLARDS				
		WEB: 1-800-BOLLARDS.COM				
		EMAIL: INFO@BOLLARDS.COM				



# 1-800-BOLLARDS

**The Bollard Experts**

- SELECT DESIRED MATERIAL:  
(8" NOMINAL SIZE)
  - FCST08080 SCH 80 ASTM A-53 CARBON STEEL
  - FCST08080 SCH 80 SATAINLESS STEEL
- SELECT DESIRED STAINLESS STEEL BOLLARD FINISH:
  - POLISHED #4 FINISH
  - AS SPECIFIED \_\_\_\_\_
- SELECT DESIRED CARBON STEEL BOLLARD FINISH:
  - POWDER COAT RAL # \_\_\_\_\_
  - AS SPECIFIED \_\_\_\_\_
- SELECT DESIRED STAINLESS STEEL BOLLARD MATERIAL:
  - TYPE 304
  - TYPE 316
- SELECT DESIRED BOLLARD CAP STYLE:
  - DOME
  - FLAT
  - REVEAL
  - SLOPED

REVISIONS			
LTR	DESCRIPTION	DATE	APP
COMMENTS			

**SPECIFICATIONS**  
 HEIGHT: 36"  
 DIAMETER: 8.625"  
 WALL THICKNESS: 0.500"

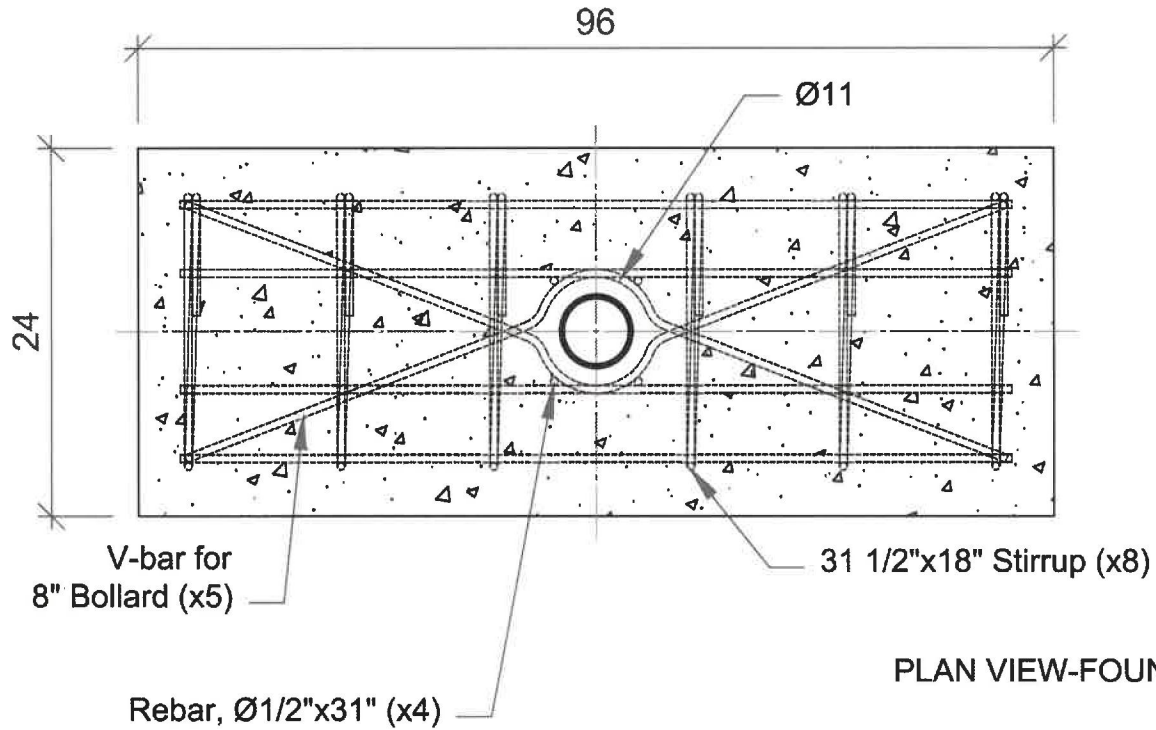

**PLAN VIEW-FOUNDATION**

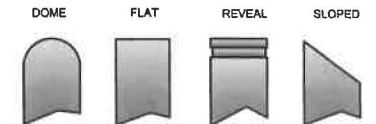

PROJECT NUMBER: CT8000 FIXED	CASE NAME: CT8	REV: 8	DATE: 1-3-2023
PROJECT FIELD: 30 MPH CRASH TESTED	DESIGN BY: AJA	DESIGNED BY: SHAWN REVA	
PROJECT CLASS: STANDARD OR CUSTOMER SPECIFIC	CHECKED BY: [blank]	REVISED BY: [blank]	
PROJECT LINE: BOLLARD	APPROVED BY: [blank]	RELEASE DATE: 1-3-2023	
PROJECT SUB LINE: FIXED	TITLE: BOLLARD, CT FIXED		
1-800-BOLLARDS, Inc. 28 Highway Suite 400 3rd Floor, CA 90008 PHONE: 1-800-BOLLARDS WEB: WWW.1800BOLLARDS.COM EMAIL: INFO@1800BOLLARDS.COM			

APPLICATION	
NEXT REV	USED ON

NOTES:  
 1. INSTALLATION TO BE COMPLETED IN ACCORDANCE WITH MANUFACTURER'S SPECIFICATIONS.  
 2. SEE ALL LOCAL ORDINANCES.  
 3. THE USER IS TO BE RESPONSIBLE FOR OBTAINING ALL NECESSARY PERMITS AND DESIGN PROFESSIONALS FOR PLANNING AND INSTALLATION PURPOSES.  
 4. ALL INFORMATION CONTAINED HEREIN IS CONFIDENTIAL AT THE TIME OF DEVELOPMENT BUT MUST BE RELEASED AND APPROVED BY THE PRODUCT MANUFACTURER TO BE CONTAINED IN ANY DOCUMENT.

# 1-800-BOLLARDS

## The Bollard Experts

- SELECT DESIRED MATERIAL:  
(8" NOMINAL SIZE)
  - FCSC T08080 SCH 80 ASTM A-53 CARBON STEEL
  - FCSC T08080 SCH 80 SATAINLESS STEEL
- SELECT DESIRED STAINLESS STEEL BOLLARD FINISH:
  - POLISHED #4 FINISH
  - AS SPECIFIED \_\_\_\_\_
- SELECT DESIRED CARBON STEEL BOLLARD FINISH:
  - POWDER COAT RAL # \_\_\_\_\_
  - AS SPECIFIED \_\_\_\_\_
- SELECT DESIRED STAINLESS STEEL BOLLARD MATERIAL:
  - TYPE 304
  - TYPE 316
- SELECT DESIRED BOLLARD CAP STYLE:
  - DOME
  - FLAT
  - REVEAL
  - SLOPED

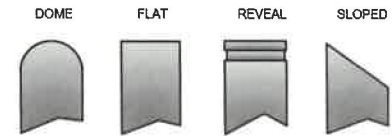
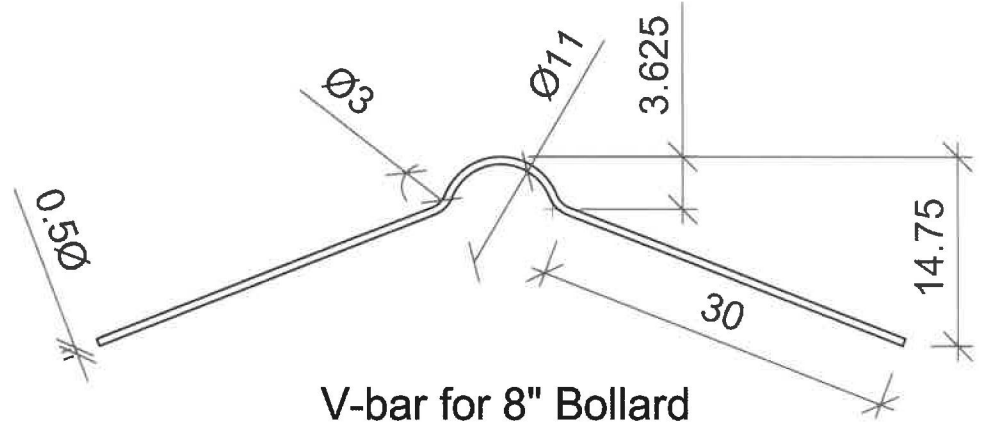
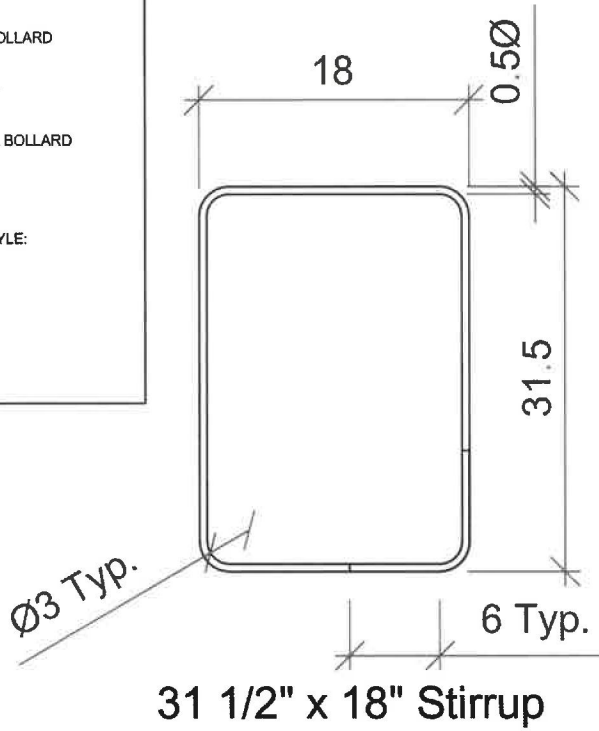

REVISIONS			
LTR	DESCRIPTION	DATE	APP'VD
COMMENTS			
SPECIFICATIONS			
HEIGHT: 36"			
DIAMETER: 8.625"			
WALL THICKNESS: 0.500"			

APPLICATION			
NEXT ASBY	USED ON	DATE CHG	REV
SERIES NAME: CT8000 FIXED		DATE CHG: CT8	REV: 8
PROJECT NAME: 30 MPH CRASH TESTED		DATE CHG: AJA	REV: CT80F
PROJECT CLASS: STANDARD OR CUSTOMER DEFINED		CHECKS BY: SHEN 1 OF 1	
PROJECT LNO: BOLLARD		APPROVED BY: _____	
PROJECT SUB LNO: FIXED		RELEASE DATE: 1-3-2023	
1-800-BOLLARDS, Inc. 30 Hughes Suite 405 Irvine, CA 92618 PHONE: 1-800-BOLLARDS WEB: 1-800-BOLLARDS.COM EMAIL: INFO@1800BOLLARDS.COM			
TITLE			BOLLARD, CT FIXED

NOTES:  
1. INSTALLATION TO BE COMPLETED IN ACCORDANCE WITH MANUFACTURER'S SPECIFICATIONS  
2. DO NOT SCALE DRAWING  
3. THIS DRAWING IS TO BE REVIEWED BY ALL APPLICANTS (ENGINEERS, CONTRACTORS, CONSULTANTS) AND DESIGN PROFESSIONALS BEFORE PLANNING AND INSTALLATION.  
4. ALL INFORMATION CONTAINED HEREIN WAS CURRENT AT THE TIME OF DEVELOPMENT & IS NOT BE REVIEWED AND APPROVED BY THE PRODUCT MANUFACTURER TO BE CONSIDERED ACCURATE

# 1-800-BOLLARDS

**The Bollard Experts**

- SELECT DESIRED MATERIAL:  
(8" NOMINAL SIZE)
  - RCST08080 SCH 80 STAINLESS STEEL
  - RCST08080 SCH 80 ASTM A-53 CARBON STEEL
- SELECT DESIRED STAINLESS STEEL BOLLARD FINISH:
  - POLISHED #4 FINISH
  - AS SPECIFIED \_\_\_\_\_
- SELECT DESIRED CARBON STEEL BOLLARD FINISH:
  - POWDER COAT RAL # \_\_\_\_\_
  - AS SPECIFIED \_\_\_\_\_
- SELECT DESIRED STAINLESS STEEL BOLLARD MATERIAL:
  - TYPE 304
  - TYPE 316
- SELECT DESIRED BOLLARD CAP STYLE:
  - DOME
  - FLAT
  - REVEAL
  - SLOPED

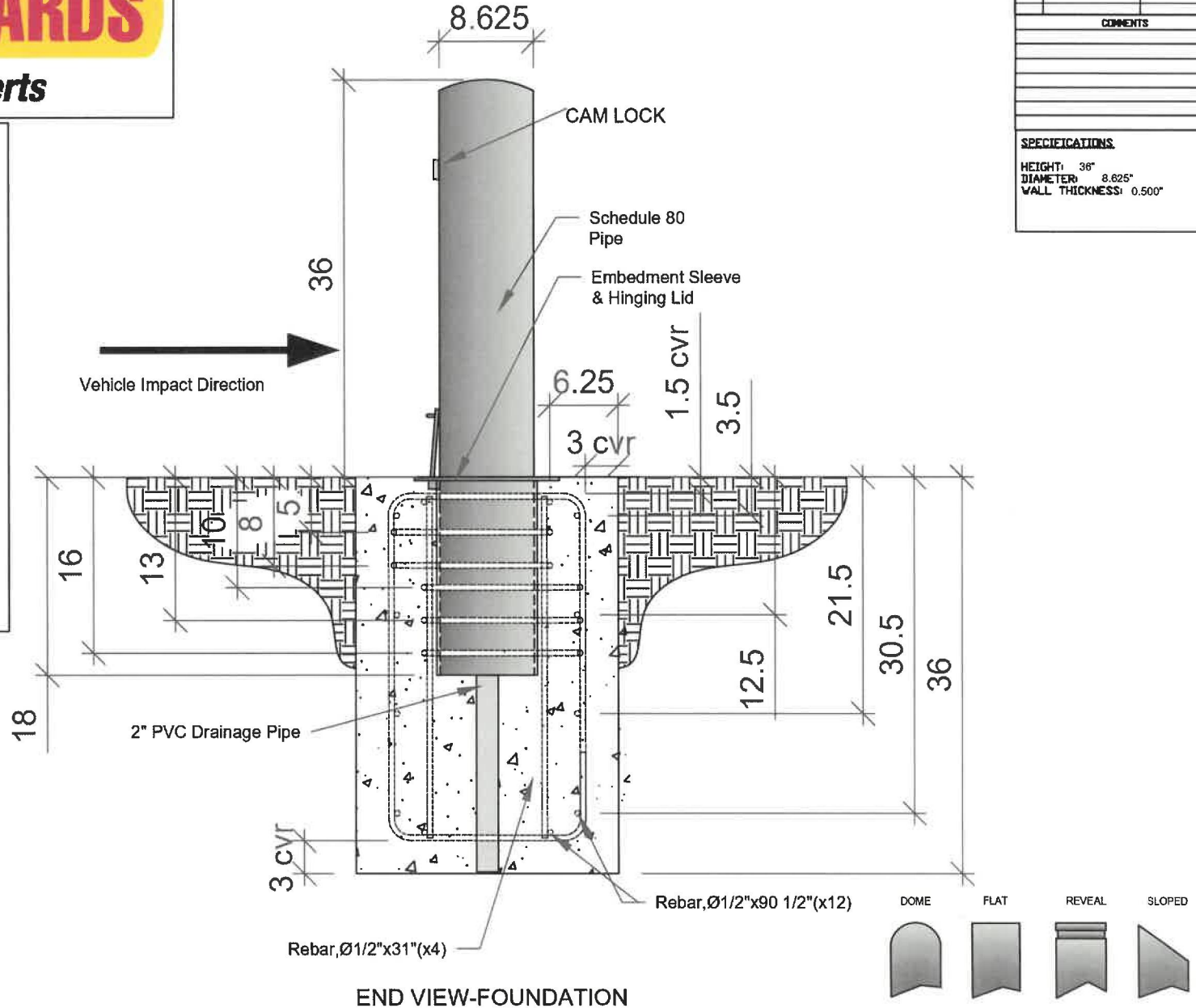

REVISIONS			
LTR	DESCRIPTION	DATE	APPVD
COMMENTS			
SPECIFICATIONS			
HEIGHT: 36"			
DIAMETER: 8.625"			
WALL THICKNESS: 0.500"			

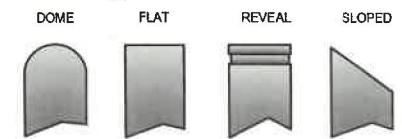





NOTES:  
 1. INSTALLATION TO BE COMPLETED IN ACCORDANCE WITH MANUFACTURER'S SPECIFICATIONS.  
 2. DO NOT SCALE DRAWING.  
 3. THIS DRAWING IS PROVIDED FOR USE BY ARCHITECTS, ENGINEERS, CONTRACTORS, CONSULTANTS AND DESIGN PROFESSIONALS FOR PLANNING AND INSTALLATION PURPOSES.  
 4. ALL INFORMATION CONTAINED HEREIN WAS CURRENT AT THE TIME OF DEVELOPMENT BUT MUST BE REVIEWED AND APPROVED BY THE PRODUCT MANUFACTURER TO BE CONSIDERED ACCURATE.

APPLICATION		REMOVABLE	
NEXT ASSY	USED ON	DATE	TITLE
1-800-BOLLARDS, Inc. 30 Hughes Super Ave Irvine, CA 92618 PHONE: 1-800-BOLLARDS WEB: 1-800-BOLLARDS.COM EMAIL: INFO@1800BOLLARDS.COM		CASE CODE: CT8 QTY: 8 DRAWING NUMBER: CT80R DRAWN BY: AJA CHECKED BY: AJA SHEET 1 OF 1 APPROVED BY: _____ RELEASE DATE: 1-3-2023	BOLLARD, CT REMOVABLE

# 1-800-BOLLARDS

The Bollard Experts

- SELECT DESIRED MATERIAL:  
(8" NOMINAL SIZE)
  - RCST08080 SCH 80 STAINLESS STEEL
  - RCST08080 SCH 80 ASTM A-53 CARBON STEEL
- SELECT DESIRED STAINLESS STEEL BOLLARD FINISH:
  - POLISHED #4 FINISH
  - AS SPECIFIED \_\_\_\_\_
- SELECT DESIRED CARBON STEEL BOLLARD FINISH:
  - POWDER COAT RAL # \_\_\_\_\_
  - AS SPECIFIED \_\_\_\_\_
- SELECT DESIRED STAINLESS STEEL BOLLARD MATERIAL:
  - TYPE 304
  - TYPE 316
- SELECT DESIRED BOLLARD CAP STYLE:
  -  DOME
  -  FLAT
  -  REVEAL
  -  SLOPED

REVISIONS			
LTR	DESCRIPTION	DATE	APP
COMMENTS			

**SPECIFICATIONS**  
 HEIGHT: 36"  
 DIAMETER: 8.625"  
 WALL THICKNESS: 0.500"

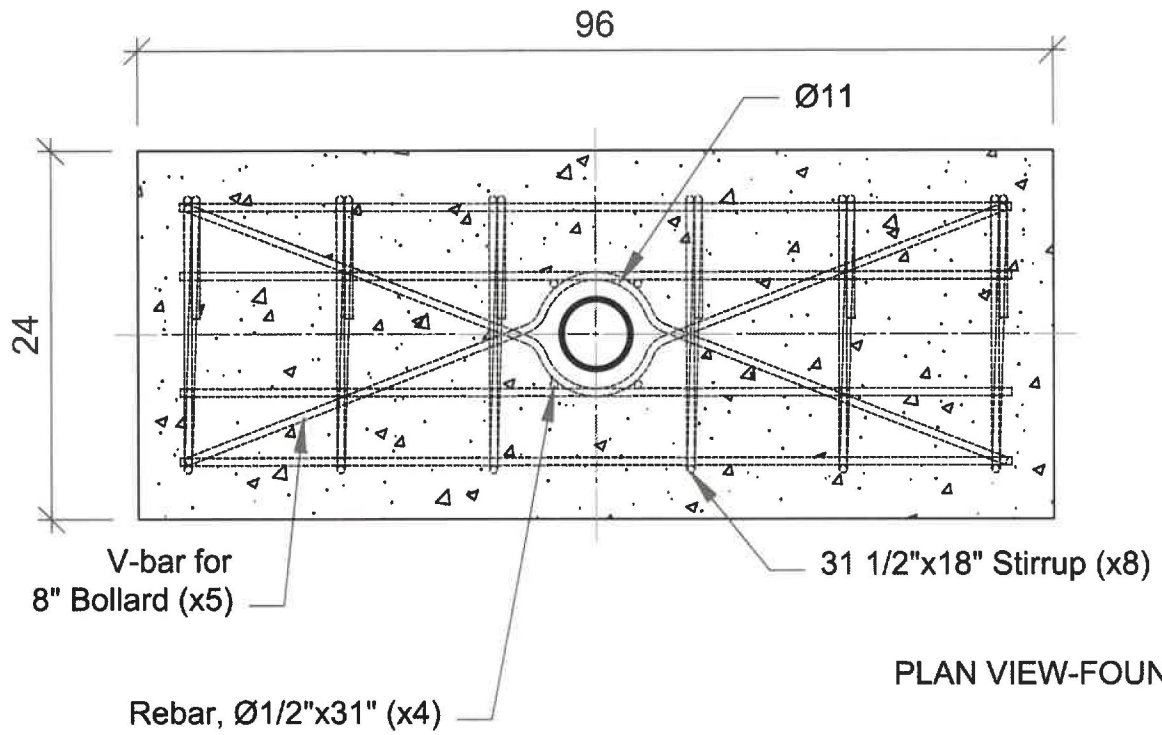

PLAN VIEW-FOUNDATION

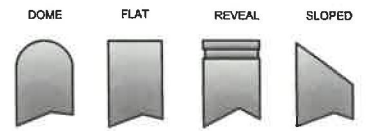





NOTES:  
 1. THIS DRAWING IS TO BE COMPLETED IN ACCORDANCE WITH MANUFACTURER'S SPECIFICATIONS.  
 2. DO NOT SCALE DRAWING.  
 3. THIS DRAWING IS INTENDED FOR USE BY ARCHITECTS, ENGINEERS, CONTRACTORS, CONSULTANTS AND DESIGN PROFESSIONALS FOR PLANNING AND INSTALLATION PURPOSES.  
 4. ALL INFORMATION CONTAINED HEREIN WAS CURRENT AT THE TIME OF DEVELOPMENT BUT MAY BE REVISED AND APPROVED BY THE PRODUCT MANUFACTURER TO BE CONSIDERED ACCURATE.

<b>APPLICATION</b>		<b>REMOVABLE</b>		<b>1-800-BOLLARDS, Inc.</b> 28 Highway Drive #200 Folsom, CA 95630 PHONE: 1-800-BOLLARDS FAX: 916-977-9444 EMAIL: INFO@1800BOLLARDS.COM	
PROJECT NUMBER	CT8000 IR	DATE FILED	CT8	REV	8
PROJECT CLASS	30 MPH CRASH TESTED	ISSUED BY	AJA	ISSUING REV	CT800R
PROJECT LIND	BOLLARD	ORDERED BY		SHEET 1 OF 1	
PROJECT NO LIND	REMOVABLE	APPROVED BY		RELEASE DATE	1-3-2023
NEXT SHEET		USED BY		TITLE	
				BOLLARD, CT REMOVABLE	

# 1-800-BOLLARDS

The Bollard Experts

- SELECT DESIRED MATERIAL:  
(8" NOMINAL SIZE)
  - RCST08080 SCH 80 STAINLESS STEEL
  - RCST08080 SCH 80 ASTM A-53 CARBON STEEL
- SELECT DESIRED STAINLESS STEEL BOLLARD FINISH:
  - POLISHED #4 FINISH
  - AS SPECIFIED \_\_\_\_\_
- SELECT DESIRED CARBON STEEL BOLLARD FINISH:
  - POWDER COAT RAL # \_\_\_\_\_
  - AS SPECIFIED \_\_\_\_\_
- SELECT DESIRED STAINLESS STEEL BOLLARD MATERIAL:
  - TYPE 304
  - TYPE 316
- SELECT DESIRED BOLLARD CAP STYLE:
  -  DOME
  -  FLAT
  -  REVEAL
  -  SLOPED

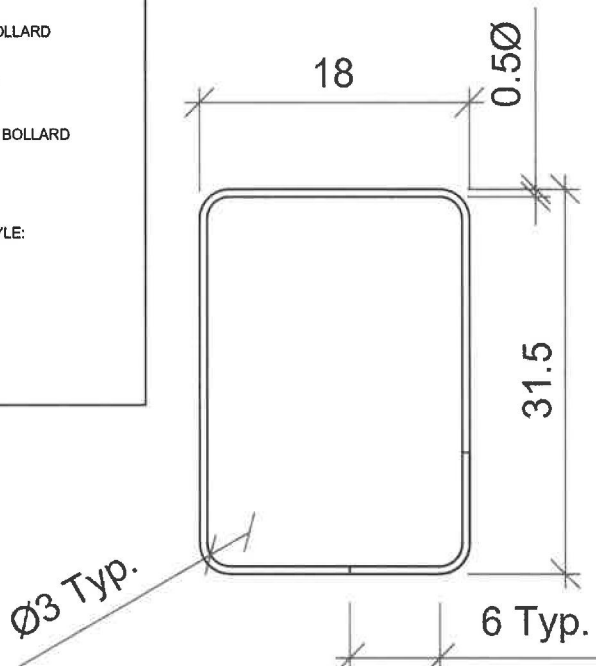

31 1/2" x 18" Stirrup

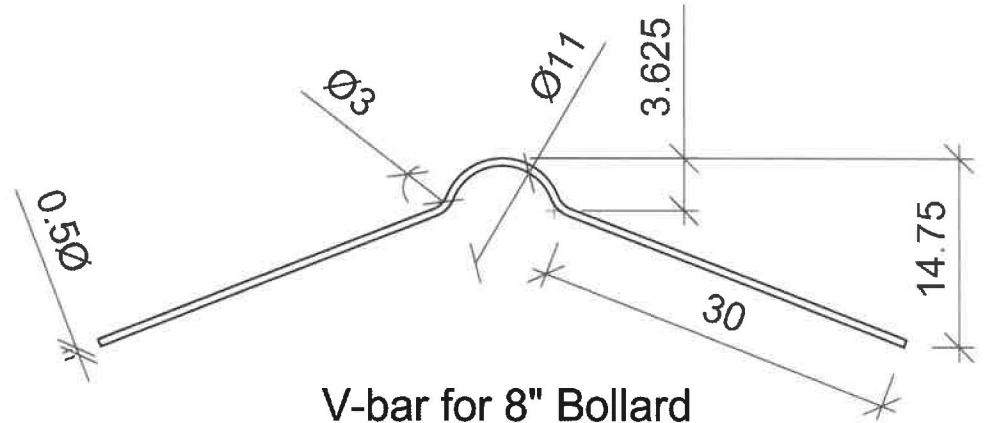

V-bar for 8" Bollard

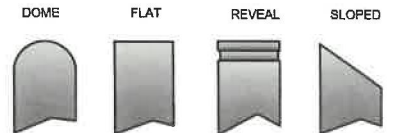

REVISIONS			
LTR	DESCRIPTION	DATE	APPVD

COMMENTS

**SPECIFICATIONS**

HEIGHT: 36"  
 DIAMETER: 8.625"  
 WALL THICKNESS: 0.500"

NOTES:  
 1. THIS DRAWING TO BE COMPLETED IN ACCORDANCE WITH MANUFACTURER'S SPECIFICATIONS.  
 2. DO NOT SCALE DRAWING.  
 3. THE COMPANY ASSUMES NO LIABILITY FOR ANY ERRORS OR OMISSIONS IN THIS DRAWING. THE MANUFACTURER'S SPECIFICATIONS SHALL BE CONSIDERED ACCURATE.

APPLICATION		1-800-BOLLARDS, Inc.	
NEXT REV	USED ON	28 Hughes Drive, Suite 1000, Irvine, CA 92618	
		PHONE: 1-800-BOLLARDS	
		WEB: 1-800-BOLLARDS.COM	
		EMAIL: INFO@1800BOLLARDS.COM	

DESIGN NUMBER: CT8000 IR	CAGE CODE: CT8	REV: 8	DRAWING NUMBER: CT80IR
PRODUCT FAMILY: 30 MPH CRASH TESTED	DRAWN BY: AJA	DESIGNED BY:	
PRODUCT CLASS: STANDARD OR CUSTOMER DEFINED	CHECKED BY:		SHEET 1 OF 1
PRODUCT LINE: BOLLARD	APPROVED BY:		RELEASE DATE: 1-3-2023
PRODUCT USE LINE: REMOVABLE	TITLE: BOLLARD, CT REMOVABLE		



Stuart Reed <estimating@merrittassociatesgcinc.com>

---

## Bollard Quote from Marty at 1-800-Bollards RE: GJ City Bollards

---

Marty Tankersley <marty@1800bollards.com>  
To: Stuart Reed <estimating@merrittassociatesgcinc.com>

Fri, May 12, 2023 at 9:29 AM

Good morning Stuart!

After speaking with my team I found out that specifics regarding our Embedment Sleeves is proprietary. I can also confirm that this is a standard in the industry for most if not all custom bollard manufacturers.

With that said, I have provided you with a drawing that shows the exact footing needed for our 8" Embedment Sleeve. You have this drawing but I've attached it again. I can also confirm that the ES is 304SS & Schedule 40. Let me know if you have any specific questions regarding the ES and I'll do my best to get you the answer.

Hope this helps!

Respectfully,

Marty Tankersley

Marty Tankersley

Corporate Sales

1-800-BOLLARDS

43171 Business Park Drive

Temecula, CA 92590-3628

(e) [marty@1800bollards.com](mailto:marty@1800bollards.com)

(w) [www.1800bollards.com](http://www.1800bollards.com)

(t) 1 (800) BOLLARDS / 1 (800) 265-5273

(c) (949) 294-2015

Certified by WBENC as a Woman-Owned Small Business

WBENC National Certification Number: WBE2202122

WOSB Certification Number: WOSB221117



Stuart Reed <estimating@merrittassociatesgcinc.com>

---

## Bollard Quote from Marty at 1-800-Bollards RE: GJ City Bollards

---

Marty Tankersley <marty@1800bollards.com>  
To: Stuart Reed <estimating@merrittassociatesgcinc.com>

Tue, May 9, 2023 at 4:23 PM

Hi Stuart,

Thank you for your patience!

I've provided a quote, cut sheet and drawings for our Fixed & Internal Locking 30mph Crash Rated bollards. Lead time is 5 to 7 weeks.

I appreciate the opportunity to earn your business. Please reach out with any questions.

Respectfully,

Marty Tankersley

Marty Tankersley

Corporate Sales

1-800-BOLLARDS

43171 Business Park Drive

Temecula, CA 92590-3628

(e) [marty@1800bollards.com](mailto:marty@1800bollards.com)

(w) [www.1800bollards.com](http://www.1800bollards.com)

(t) 1 (800) BOLLARDS / 1 (800) 265-5273

(c) (949) 294-2015

Due to the lead time of 5-7 weeks to receive the Bollards, Merritt & Associates GC Inc. proposes that our project start time begins after Bollard materials arrive.

Thank you,

Merritt Sixbey

President, MAGC Inc.

Certified by WBENC as a Woman-Owned Small Business

WBENC National Certification Number: WBE2202122

WOSB Certification Number: WOSB221117



Stuart Reed <estimating@merrittassociatesgcinc.com>

---

## Bollard Quote from Marty at 1-800-Bollards RE: GJ City Bollards

---

Marty Tankersley <marty@1800bollards.com>  
To: Stuart Reed <estimating@merrittassociatesgcinc.com>

Tue, May 23, 2023 at 9:50 AM

Hi Stuart,

Here is our warranty information which can also be found in the quote I sent you. Please let me know if you have any questions.

### VI. Warranty

1-800-BOLLARDS warrants the equipment manufactured to be free from defects in material and workmanship for 12 months from time of shipment. 1-800-BOLLARDS repair or replace at its option any product which it determines to contain defective material and workmanship. Our warranty does not extend to "fair wear" and "tear" or negligent use of our product. This warranty is in lieu of all other warranties expressed or implied. 1-800-BOLLARDS shall not be liable for any special indirect, incidental or consequent damages of any kind or nature.

The Purchaser acknowledges and agrees with 1-800-BOLLARDS:

1. That it is satisfied that the goods are suitable for its intended purpose.
2. That in all matters relating to the goods, the Purchaser has relied and will rely entirely upon the Purchaser's own judgment.
- B. That no warranty as to the fitness for any particular purpose will apply to this contract. Delivery and/or installation shall be conclusive evidence that the goods accord in any respect with the Purchaser's requirements and are in good condition and complete in all respects.
- C. That any implied warranty or condition, whether Statutory or otherwise, and whether as to the quality, state, condition or fitness for any particular purpose or as to any other matter or thing whatsoever is hereby expressly excluded from this contract. Any and all advice, recommendation, information, assistance, or service provided by 1-800-BOLLARDS staff in relation to goods or services sold is given in good faith and is believed by 1-800-BOLLARDS to be appropriate and reliable. The Purchaser acknowledges that such advice, recommendation, information, assistance, or service is provided as an act of good faith and do not indicate any expertise particular to 1-800-BOLLARDS and acknowledges that such advice, recommendation, information, assistance, or service is provided without liability or responsibility on the part of 1-800-BOLLARDS.

Respectfully,

Marty Tankersley

Marty Tankersley



# **1-800-BOLLARDS**

## ***The Bollard Experts***

Thank you for your interest in 1-800-BOLLARDS.

Please find the attached proposal per your project. If you have any further questions related to the proposal or our products listed, please do not hesitate to contact me. Our complete range of bollard products are produced from the highest quality materials then finished to the highest quality standards and specifications.

1-800-BOLLARDS stands by our quality with a one-year warranty on all products from our simplest industrial bollards to our most sophisticated Department of State rated automated retractable bollard system.

To proceed with an order, simply return your purchase order or sign and return the attached proposal.

Thank you for your consideration. We look forward to doing business with you.

Best regards,  
Marty Tankersley  
Email: [marty@1800bollards.com](mailto:marty@1800bollards.com)  
Web: [www.1800bollards.com](http://www.1800bollards.com)  
Toll Free: 1-800-BOLLARDS / 1 (800) 265-5273  
Fax: (949) 528-6012

# AIA<sup>®</sup> Document A312<sup>™</sup> – 2010

## Payment Bond

**CONTRACTOR:**

*(Name, legal status and address)*

Merritt & Associates GC Inc.  
2108 Highway 6 & 50  
Grand Junction, CO 81505

**SURETY:**

*(Name, legal status and principal place of business)*

The Ohio Casualty Insurance Company  
10800 E Geddes Ave. Ste. 160  
Englewood, CO 80112

**OWNER:**

*(Name, legal status and address)*

City of Grand Junction  
250 North 5th Street  
Grand Junction, CO 81501

**CONSTRUCTION CONTRACT**

Date: June 1, 2023

Amount: \$ 147,253.20

Description:

*(Name and location)*

Safety Bollard Purchase and Installation Project IFB-5244-23-KF  
Grand Junction, CO

**ADDITIONS AND DELETIONS:**

The author of this document has added information needed for its completion. The author may also have revised the text of the original AIA standard form. An *Additions and Deletions Report* that notes added information as well as revisions to the standard form text is available from the author and should be reviewed. A vertical line in the left margin of this document indicates where the author has added necessary information and where the author has added to or deleted from the original AIA text.

This document has important legal consequences. Consultation with an attorney is encouraged with respect to its completion or modification.

Any singular reference to Contractor, Surety, Owner or other party shall be considered plural where applicable.

**BOND**

Date: June 9, 2023

*(Not earlier than Construction Contract Date)*

Amount: \$ 147,253.20

Modifications to this Bond:  None  See Section 18

**CONTRACTOR AS PRINCIPAL**

Company: *(Corporate Seal)*

Merritt & Associates GC Inc.

Signature: 

Name and

Title: Brian Holton, Vice President

*(Any additional signatures appear on the last page of this Payment Bond.)*

**SURETY**

Company: *(Corporate Seal)*

The Ohio Casualty Insurance Company

Signature: 

Name and

Title: Darren Coltrinari, Attorney-in-fact

*(FOR INFORMATION ONLY — Name, address and telephone)*

**AGENT or BROKER:**

Home Loan & Investment Company

205 N 4th Street

Grand Junction, CO 81501

(970)254-0828

**OWNER'S REPRESENTATIVE:**

*(Architect, Engineer or other party:)*

Int.

§ 1 The Contractor and Surety, jointly and severally, bind themselves, their heirs, executors, administrators, successors and assigns to the Owner to pay for labor, materials and equipment furnished for use in the performance of the Construction Contract, which is incorporated herein by reference, subject to the following terms.

§ 2 If the Contractor promptly makes payment of all sums due to Claimants, and defends, indemnifies and holds harmless the Owner from claims, demands, liens or suits by any person or entity seeking payment for labor, materials or equipment furnished for use in the performance of the Construction Contract, then the Surety and the Contractor shall have no obligation under this Bond.

§ 3 If there is no Owner Default under the Construction Contract, the Surety's obligation to the Owner under this Bond shall arise after the Owner has promptly notified the Contractor and the Surety (at the address described in Section 13) of claims, demands, liens or suits against the Owner or the Owner's property by any person or entity seeking payment for labor, materials or equipment furnished for use in the performance of the Construction Contract and tendered defense of such claims, demands, liens or suits to the Contractor and the Surety.

§ 4 When the Owner has satisfied the conditions in Section 3, the Surety shall promptly and at the Surety's expense defend, indemnify and hold harmless the Owner against a duly tendered claim, demand, lien or suit.

§ 5 The Surety's obligations to a Claimant under this Bond shall arise after the following:

§ 5.1 Claimants, who do not have a direct contract with the Contractor,

- .1 have furnished a written notice of non-payment to the Contractor, stating with substantial accuracy the amount claimed and the name of the party to whom the materials were, or equipment was, furnished or supplied or for whom the labor was done or performed, within ninety (90) days after having last performed labor or last furnished materials or equipment included in the Claim; and
- .2 have sent a Claim to the Surety (at the address described in Section 13).

§ 5.2 Claimants, who are employed by or have a direct contract with the Contractor, have sent a Claim to the Surety (at the address described in Section 13).

§ 6 If a notice of non-payment required by Section 5.1.1 is given by the Owner to the Contractor, that is sufficient to satisfy a Claimant's obligation to furnish a written notice of non-payment under Section 5.1.1.

§ 7 When a Claimant has satisfied the conditions of Sections 5.1 or 5.2, whichever is applicable, the Surety shall promptly and at the Surety's expense take the following actions:

§ 7.1 Send an answer to the Claimant, with a copy to the Owner, within sixty (60) days after receipt of the Claim, stating the amounts that are undisputed and the basis for challenging any amounts that are disputed; and

§ 7.2 Pay or arrange for payment of any undisputed amounts.

§ 7.3 The Surety's failure to discharge its obligations under Section 7.1 or Section 7.2 shall not be deemed to constitute a waiver of defenses the Surety or Contractor may have or acquire as to a Claim, except as to undisputed amounts for which the Surety and Claimant have reached agreement. If, however, the Surety fails to discharge its obligations under Section 7.1 or Section 7.2, the Surety shall indemnify the Claimant for the reasonable attorney's fees the Claimant incurs thereafter to recover any sums found to be due and owing to the Claimant.

§ 8 The Surety's total obligation shall not exceed the amount of this Bond, plus the amount of reasonable attorney's fees provided under Section 7.3, and the amount of this Bond shall be credited for any payments made in good faith by the Surety.

§ 9 Amounts owed by the Owner to the Contractor under the Construction Contract shall be used for the performance of the Construction Contract and to satisfy claims, if any, under any construction performance bond. By the Contractor furnishing and the Owner accepting this Bond, they agree that all funds earned by the Contractor in the performance of the Construction Contract are dedicated to satisfy obligations of the Contractor and Surety under this Bond, subject to the Owner's priority to use the funds for the completion of the work.

Init.

§ 10 The Surety shall not be liable to the Owner, Claimants or others for obligations of the Contractor that are unrelated to the Construction Contract. The Owner shall not be liable for the payment of any costs or expenses of any Claimant under this Bond, and shall have under this Bond no obligation to make payments to, or give notice on behalf of, Claimants or otherwise have any obligations to Claimants under this Bond.

§ 11 The Surety hereby waives notice of any change, including changes of time, to the Construction Contract or to related subcontracts, purchase orders and other obligations.

§ 12 No suit or action shall be commenced by a Claimant under this Bond other than in a court of competent jurisdiction in the state in which the project that is the subject of the Construction Contract is located or after the expiration of one year from the date (1) on which the Claimant sent a Claim to the Surety pursuant to Section 5.1.2 or 5.2, or (2) on which the last labor or service was performed by anyone or the last materials or equipment were furnished by anyone under the Construction Contract, whichever of (1) or (2) first occurs. If the provisions of this Paragraph are void or prohibited by law, the minimum period of limitation available to sureties as a defense in the jurisdiction of the suit shall be applicable.

§ 13 Notice and Claims to the Surety, the Owner or the Contractor shall be mailed or delivered to the address shown on the page on which their signature appears. Actual receipt of notice or Claims, however accomplished, shall be sufficient compliance as of the date received.

§ 14 When this Bond has been furnished to comply with a statutory or other legal requirement in the location where the construction was to be performed, any provision in this Bond conflicting with said statutory or legal requirement shall be deemed deleted herefrom and provisions conforming to such statutory or other legal requirement shall be deemed incorporated herein. When so furnished, the intent is that this Bond shall be construed as a statutory bond and not as a common law bond.

§ 15 Upon request by any person or entity appearing to be a potential beneficiary of this Bond, the Contractor and Owner shall promptly furnish a copy of this Bond or shall permit a copy to be made.

#### § 16 Definitions

§ 16.1 Claim. A written statement by the Claimant including at a minimum:

- .1 the name of the Claimant;
- .2 the name of the person for whom the labor was done, or materials or equipment furnished;
- .3 a copy of the agreement or purchase order pursuant to which labor, materials or equipment was furnished for use in the performance of the Construction Contract;
- .4 a brief description of the labor, materials or equipment furnished;
- .5 the date on which the Claimant last performed labor or last furnished materials or equipment for use in the performance of the Construction Contract;
- .6 the total amount earned by the Claimant for labor, materials or equipment furnished as of the date of the Claim;
- .7 the total amount of previous payments received by the Claimant; and
- .8 the total amount due and unpaid to the Claimant for labor, materials or equipment furnished as of the date of the Claim.

§ 16.2 Claimant. An individual or entity having a direct contract with the Contractor or with a subcontractor of the Contractor to furnish labor, materials or equipment for use in the performance of the Construction Contract. The term Claimant also includes any individual or entity that has rightfully asserted a claim under an applicable mechanic's lien or similar statute against the real property upon which the Project is located. The intent of this Bond shall be to include without limitation in the terms "labor, materials or equipment" that part of water, gas, power, light, heat, oil, gasoline, telephone service or rental equipment used in the Construction Contract, architectural and engineering services required for performance of the work of the Contractor and the Contractor's subcontractors, and all other items for which a mechanic's lien may be asserted in the jurisdiction where the labor, materials or equipment were furnished.

§ 16.3 Construction Contract. The agreement between the Owner and Contractor identified on the cover page, including all Contract Documents and all changes made to the agreement and the Contract Documents.

Init.

§ 16.4 Owner Default. Failure of the Owner, which has not been remedied or waived, to pay the Contractor as required under the Construction Contract or to perform and complete or comply with the other material terms of the Construction Contract.

§ 16.5 Contract Documents. All the documents that comprise the agreement between the Owner and Contractor.

§ 17 If this Bond is issued for an agreement between a Contractor and subcontractor, the term Contractor in this Bond shall be deemed to be Subcontractor and the term Owner shall be deemed to be Contractor.

§ 18 Modifications to this bond are as follows:

*(Space is provided below for additional signatures of added parties, other than those appearing on the cover page.)*

**CONTRACTOR AS PRINCIPAL**

Company: \_\_\_\_\_ (Corporate Seal)

Signature: 

Name and Title: Brian Holton VP

Address: 2108 Highway 6050

**SURETY**

Company: \_\_\_\_\_ (Corporate Seal)

The Ohio Casualty Insurance Company

Signature: \_\_\_\_\_

Name and Title: \_\_\_\_\_

Address: \_\_\_\_\_

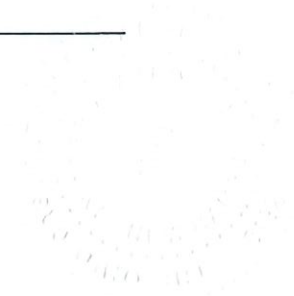

# AIA<sup>®</sup> Document A312<sup>™</sup> – 2010

## Performance Bond

**CONTRACTOR:**

*(Name, legal status and address)*

Merritt & Associates GC Inc.  
2108 Highway 6 & 50  
Grand Junction, CO 81505

**SURETY:**

*(Name, legal status and principal place of business)*

The Ohio Casualty Insurance Company  
10800 E Geddes Ave. Ste. 160  
Englewood, CO 80112

**ADDITIONS AND DELETIONS:**

The author of this document has added information needed for its completion. The author may also have revised the text of the original AIA standard form. An *Additions and Deletions Report* that notes added information as well as revisions to the standard form text is available from the author and should be reviewed. A vertical line in the left margin of this document indicates where the author has added necessary information and where the author has added to or deleted from the original AIA text.

**OWNER:**

*(Name, legal status and address)*

City of Grand Junction  
250 North 5th Street  
Grand Junction, CO 81501

This document has important legal consequences. Consultation with an attorney is encouraged with respect to its completion or modification.

**CONSTRUCTION CONTRACT**

Date: June 1, 2023

Amount: \$ 147,253.20

Description:

*(Name and location)*

Safety Bollard Purchase and Installation Project IFB-5244-23-KF  
Grand Junction, CO

Any singular reference to Contractor, Surety, Owner or other party shall be considered plural where applicable.

**BOND**

Date: June 9, 2023

*(Not earlier than Construction Contract Date)*

Amount: \$ 147,253.20

Modifications to this Bond:  None  See Section 16

**CONTRACTOR AS PRINCIPAL**

Company: *(Corporate Seal)*

Merritt & Associates GC Inc.

Signature: 

Name and

Title: Brian Holton, Vice President

*(Any additional signatures appear on the last page of this Performance Bond.)*

**SURETY**

Company: *(Corporate Seal)*

The Ohio Casualty Insurance Company

Signature: 

Name and Title: Darren Coltrinari, Attorney-in-fact

*(FOR INFORMATION ONLY — Name, address and telephone)*

**AGENT or BROKER:**

Home Loan & Investment Company

205 N 4th Street

Grand Junction, CO 81501

(970)254-0828

**OWNER'S REPRESENTATIVE:**

*(Architect, Engineer or other party:)*

§ 1 The Contractor and Surety, jointly and severally, bind themselves, their heirs, executors, administrators, successors and assigns to the Owner for the performance of the Construction Contract, which is incorporated herein by reference.

§ 2 If the Contractor performs the Construction Contract, the Surety and the Contractor shall have no obligation under this Bond, except when applicable to participate in a conference as provided in Section 3.

§ 3 If there is no Owner Default under the Construction Contract, the Surety's obligation under this Bond shall arise after

- .1 the Owner first provides notice to the Contractor and the Surety that the Owner is considering declaring a Contractor Default. Such notice shall indicate whether the Owner is requesting a conference among the Owner, Contractor and Surety to discuss the Contractor's performance. If the Owner does not request a conference, the Surety may, within five (5) business days after receipt of the Owner's notice, request such a conference. If the Surety timely requests a conference, the Owner shall attend. Unless the Owner agrees otherwise, any conference requested under this Section 3.1 shall be held within ten (10) business days of the Surety's receipt of the Owner's notice. If the Owner, the Contractor and the Surety agree, the Contractor shall be allowed a reasonable time to perform the Construction Contract, but such an agreement shall not waive the Owner's right, if any, subsequently to declare a Contractor Default;
- .2 the Owner declares a Contractor Default, terminates the Construction Contract and notifies the Surety; and
- .3 the Owner has agreed to pay the Balance of the Contract Price in accordance with the terms of the Construction Contract to the Surety or to a contractor selected to perform the Construction Contract.

§ 4 Failure on the part of the Owner to comply with the notice requirement in Section 3.1 shall not constitute a failure to comply with a condition precedent to the Surety's obligations, or release the Surety from its obligations, except to the extent the Surety demonstrates actual prejudice.

§ 5 When the Owner has satisfied the conditions of Section 3, the Surety shall promptly and at the Surety's expense take one of the following actions:

§ 5.1 Arrange for the Contractor, with the consent of the Owner, to perform and complete the Construction Contract;

§ 5.2 Undertake to perform and complete the Construction Contract itself, through its agents or independent contractors;

§ 5.3 Obtain bids or negotiated proposals from qualified contractors acceptable to the Owner for a contract for performance and completion of the Construction Contract, arrange for a contract to be prepared for execution by the Owner and a contractor selected with the Owner's concurrence, to be secured with performance and payment bonds executed by a qualified surety equivalent to the bonds issued on the Construction Contract, and pay to the Owner the amount of damages as described in Section 7 in excess of the Balance of the Contract Price incurred by the Owner as a result of the Contractor Default; or

§ 5.4 Waive its right to perform and complete, arrange for completion, or obtain a new contractor and with reasonable promptness under the circumstances:

- .1 After investigation, determine the amount for which it may be liable to the Owner and, as soon as practicable after the amount is determined, make payment to the Owner; or
- .2 Deny liability in whole or in part and notify the Owner, citing the reasons for denial.

§ 6 If the Surety does not proceed as provided in Section 5 with reasonable promptness, the Surety shall be deemed to be in default on this Bond seven days after receipt of an additional written notice from the Owner to the Surety demanding that the Surety perform its obligations under this Bond, and the Owner shall be entitled to enforce any remedy available to the Owner. If the Surety proceeds as provided in Section 5.4, and the Owner refuses the payment or the Surety has denied liability, in whole or in part, without further notice the Owner shall be entitled to enforce any remedy available to the Owner.

§ 7 If the Surety elects to act under Section 5.1, 5.2 or 5.3, then the responsibilities of the Surety to the Owner shall not be greater than those of the Contractor under the Construction Contract, and the responsibilities of the Owner to the Surety shall not be greater than those of the Owner under the Construction Contract. Subject to the commitment by the Owner to pay the Balance of the Contract Price, the Surety is obligated, without duplication, for

- .1 the responsibilities of the Contractor for correction of defective work and completion of the Construction Contract;
- .2 additional legal, design professional and delay costs resulting from the Contractor's Default, and resulting from the actions or failure to act of the Surety under Section 5; and
- .3 liquidated damages, or if no liquidated damages are specified in the Construction Contract, actual damages caused by delayed performance or non-performance of the Contractor.

§ 8 If the Surety elects to act under Section 5.1, 5.3 or 5.4, the Surety's liability is limited to the amount of this Bond.

§ 9 The Surety shall not be liable to the Owner or others for obligations of the Contractor that are unrelated to the Construction Contract, and the Balance of the Contract Price shall not be reduced or set off on account of any such unrelated obligations. No right of action shall accrue on this Bond to any person or entity other than the Owner or its heirs, executors, administrators, successors and assigns.

§ 10 The Surety hereby waives notice of any change, including changes of time, to the Construction Contract or to related subcontracts, purchase orders and other obligations.

§ 11 Any proceeding, legal or equitable, under this Bond may be instituted in any court of competent jurisdiction in the location in which the work or part of the work is located and shall be instituted within two years after a declaration of Contractor Default or within two years after the Contractor ceased working or within two years after the Surety refuses or fails to perform its obligations under this Bond, whichever occurs first. If the provisions of this Paragraph are void or prohibited by law, the minimum period of limitation available to sureties as a defense in the jurisdiction of the suit shall be applicable.

§ 12 Notice to the Surety, the Owner or the Contractor shall be mailed or delivered to the address shown on the page on which their signature appears.

§ 13 When this Bond has been furnished to comply with a statutory or other legal requirement in the location where the construction was to be performed, any provision in this Bond conflicting with said statutory or legal requirement shall be deemed deleted herefrom and provisions conforming to such statutory or other legal requirement shall be deemed incorporated herein. When so furnished, the intent is that this Bond shall be construed as a statutory bond and not as a common law bond.

#### § 14 Definitions

§ 14.1 **Balance of the Contract Price.** The total amount payable by the Owner to the Contractor under the Construction Contract after all proper adjustments have been made, including allowance to the Contractor of any amounts received or to be received by the Owner in settlement of insurance or other claims for damages to which the Contractor is entitled, reduced by all valid and proper payments made to or on behalf of the Contractor under the Construction Contract.

§ 14.2 **Construction Contract.** The agreement between the Owner and Contractor identified on the cover page, including all Contract Documents and changes made to the agreement and the Contract Documents.

§ 14.3 **Contractor Default.** Failure of the Contractor, which has not been remedied or waived, to perform or otherwise to comply with a material term of the Construction Contract.

§ 14.4 **Owner Default.** Failure of the Owner, which has not been remedied or waived, to pay the Contractor as required under the Construction Contract or to perform and complete or comply with the other material terms of the Construction Contract.

§ 14.5 **Contract Documents.** All the documents that comprise the agreement between the Owner and Contractor.

Init.



§ 15 If this Bond is issued for an agreement between a Contractor and subcontractor, the term Contractor in this Bond shall be deemed to be Subcontractor and the term Owner shall be deemed to be Contractor.

§ 16 Modifications to this bond are as follows:

*(Space is provided below for additional signatures of added parties, other than those appearing on the cover page.)*

**CONTRACTOR AS PRINCIPAL**

Company:

*(Corporate Seal)*

Signature:

Name and Title:

Address:



*Brian Holton VP*

*2108 Highway 6850*

**SURETY**

Company:

*(Corporate Seal)*

Signature:

Name and Title:

Address:

\_\_\_\_\_

Init.

User Notes:

(1330464353)



This Power of Attorney limits the acts of those named herein, and they have no authority to bind the Company except in the manner and to the extent herein stated.

Liberty Mutual Insurance Company
The Ohio Casualty Insurance Company
West American Insurance Company

Certificate No: 8202431-972883

POWER OF ATTORNEY

KNOWN ALL PERSONS BY THESE PRESENTS: That The Ohio Casualty Insurance Company is a corporation duly organized under the laws of the State of New Hampshire, that Liberty Mutual Insurance Company is a corporation duly organized under the laws of the State of Massachusetts, and West American Insurance Company is a corporation duly organized under the laws of the State of Indiana (herein collectively called the "Companies"), pursuant to and by authority herein set forth, does hereby name, constitute and appoint, Darren Coltrinari, Rich J. Englehart, Jerry Hamilton

all of the city of Grand Junction state of Colorado each individually if there be more than one named, its true and lawful attorney-in-fact to make, execute, seal, acknowledge and deliver, for and on its behalf as surety and as its act and deed, any and all undertakings, bonds, recognizances and other surety obligations, in pursuance of these presents and shall be as binding upon the Companies as if they have been duly signed by the president and attested by the secretary of the Companies in their own proper persons.

IN WITNESS WHEREOF, this Power of Attorney has been subscribed by an authorized officer or official of the Companies and the corporate seals of the Companies have been affixed thereto this 25th day of October, 2019.



Liberty Mutual Insurance Company
The Ohio Casualty Insurance Company
West American Insurance Company

By: David M. Carey

David M. Carey, Assistant Secretary

Not valid for mortgage, note, loan, letter of credit, currency rate, interest rate or residual value guarantees.

To confirm the validity of this Power of Attorney call 1-610-832-8240 between 9:00 am and 4:30 pm EST on any business day.

State of PENNSYLVANIA
County of MONTGOMERY ss

On this 25th day of October, 2019 before me personally appeared David M. Carey, who acknowledged himself to be the Assistant Secretary of Liberty Mutual Insurance Company, The Ohio Casualty Company, and West American Insurance Company, and that he, as such, being authorized so to do, execute the foregoing instrument for the purposes therein contained by signing on behalf of the corporations by himself as a duly authorized officer.

IN WITNESS WHEREOF, I have hereunto subscribed my name and affixed my notarial seal at King of Prussia, Pennsylvania, on the day and year first above written.



COMMONWEALTH OF PENNSYLVANIA
Notarial Seal
Teresa Pastella, Notary Public
Upper Merion Twp., Montgomery County
My Commission Expires March 28, 2021
Member, Pennsylvania Association of Notaries

By: Teresa Pastella
Teresa Pastella, Notary Public

This Power of Attorney is made and executed pursuant to and by authority of the following By-laws and Authorizations of The Ohio Casualty Insurance Company, Liberty Mutual Insurance Company, and West American Insurance Company which resolutions are now in full force and effect reading as follows:

ARTICLE IV - OFFICERS: Section 12. Power of Attorney.

Any officer or other official of the Corporation authorized for that purpose in writing by the Chairman or the President, and subject to such limitation as the Chairman or the President may prescribe, shall appoint such attorneys-in-fact, as may be necessary to act in behalf of the Corporation to make, execute, seal, acknowledge and deliver as surety any and all undertakings, bonds, recognizances and other surety obligations. Such attorneys-in-fact, subject to the limitations set forth in their respective powers of attorney, shall have full power to bind the Corporation by their signature and execution of any such instruments and to attach thereto the seal of the Corporation. When so executed, such instruments shall be as binding as if signed by the President and attested to by the Secretary. Any power or authority granted to any representative or attorney-in-fact under the provisions of this article may be revoked at any time by the Board, the Chairman, the President or by the officer or officers granting such power or authority.

ARTICLE XIII - Execution of Contracts: Section 5. Surety Bonds and Undertakings.

Any officer of the Company authorized for that purpose in writing by the chairman or the president, and subject to such limitations as the chairman or the president may prescribe, shall appoint such attorneys-in-fact, as may be necessary to act in behalf of the Company to make, execute, seal, acknowledge and deliver as surety any and all undertakings, bonds, recognizances and other surety obligations. Such attorneys-in-fact subject to the limitations set forth in their respective powers of attorney, shall have full power to bind the Company by their signature and execution of any such instruments and to attach thereto the seal of the Company. When so executed such instruments shall be as binding as if signed by the president and attested by the secretary.

Certificate of Designation - The President of the Company, acting pursuant to the Bylaws of the Company, authorizes David M. Carey, Assistant Secretary to appoint such attorneys-in-fact as may be necessary to act on behalf of the Company to make, execute, seal, acknowledge and deliver as surety any and all undertakings, bonds, recognizances and other surety obligations.

Authorization - By unanimous consent of the Company's Board of Directors, the Company consents that facsimile or mechanically reproduced signature of any assistant secretary of the Company, wherever appearing upon a certified copy of any power of attorney issued by the Company in connection with surety bonds, shall be valid and binding upon the Company with the same force and effect as though manually affixed.

I, Renee C. Llewellyn, the undersigned, Assistant Secretary, The Ohio Casualty Insurance Company, Liberty Mutual Insurance Company, and West American Insurance Company do hereby certify that the original power of attorney of which the foregoing is a full, true and correct copy of the Power of Attorney executed by said Companies, is in full force and effect and has not been revoked.

IN TESTIMONY WHEREOF, I have hereunto set my hand and affixed the seals of said Companies this 9th day of June, 2023.



By: Renee C. Llewellyn

Renee C. Llewellyn, Assistant Secretary



MERRCON-01

SARAM

# CERTIFICATE OF LIABILITY INSURANCE

DATE (MM/DD/YYYY)  
**6/15/2023**

THIS CERTIFICATE IS ISSUED AS A MATTER OF INFORMATION ONLY AND CONFERS NO RIGHTS UPON THE CERTIFICATE HOLDER. THIS CERTIFICATE DOES NOT AFFIRMATIVELY OR NEGATIVELY AMEND, EXTEND OR ALTER THE COVERAGE AFFORDED BY THE POLICIES BELOW. THIS CERTIFICATE OF INSURANCE DOES NOT CONSTITUTE A CONTRACT BETWEEN THE ISSUING INSURER(S), AUTHORIZED REPRESENTATIVE OR PRODUCER, AND THE CERTIFICATE HOLDER.

IMPORTANT: If the certificate holder is an ADDITIONAL INSURED, the policy(ies) must have ADDITIONAL INSURED provisions or be endorsed. If SUBROGATION IS WAIVED, subject to the terms and conditions of the policy, certain policies may require an endorsement. A statement on this certificate does not confer rights to the certificate holder in lieu of such endorsement(s).

PRODUCER <b>Home Loan &amp; Investment Company</b> 205 North 4th Street Grand Junction, CO 81501	CONTACT NAME: <b>Sara Mendenhall</b>		
	PHONE (A/C, No, Ext): <b>(970) 254-0846</b>	FAX (A/C, No): <b>(970) 243-3914</b>	
	E-MAIL ADDRESS: <b>saram@hlic.com</b>		
INSURER(S) AFFORDING COVERAGE		NAIC #	
INSURED  <b>Merritt &amp; Associates G C Inc</b> 2108 Highway 6 & 50 Grand Junction, CO 81505	INSURER A: <b>Selective Insurance Company Of America</b>		<b>12572</b>
	INSURER B: <b>Pinnacol Assurance</b>		<b>41190</b>
	INSURER C:		
	INSURER D:		
	INSURER E:		
INSURER F:			

**COVERAGES**                                      **CERTIFICATE NUMBER:**                                      **REVISION NUMBER:**

THIS IS TO CERTIFY THAT THE POLICIES OF INSURANCE LISTED BELOW HAVE BEEN ISSUED TO THE INSURED NAMED ABOVE FOR THE POLICY PERIOD INDICATED. NOTWITHSTANDING ANY REQUIREMENT, TERM OR CONDITION OF ANY CONTRACT OR OTHER DOCUMENT WITH RESPECT TO WHICH THIS CERTIFICATE MAY BE ISSUED OR MAY PERTAIN, THE INSURANCE AFFORDED BY THE POLICIES DESCRIBED HEREIN IS SUBJECT TO ALL THE TERMS, EXCLUSIONS AND CONDITIONS OF SUCH POLICIES. LIMITS SHOWN MAY HAVE BEEN REDUCED BY PAID CLAIMS.

INSR LTR	TYPE OF INSURANCE	ADDL INSD	SUBR WVD	POLICY NUMBER	POLICY EFF (MM/DD/YYYY)	POLICY EXP (MM/DD/YYYY)	LIMITS	
A X	COMMERCIAL GENERAL LIABILITY CLAIMS-MADE <input checked="checked" type="checkbox"/> OCCUR			S2323596	6/1/2023	6/1/2024	EACH OCCURRENCE	\$ 1,000,000
							DAMAGE TO RENTED PREMISES (Ea occurrence)	\$ 500,000
							MED EXP (Any one person)	\$ 15,000
							PERSONAL & ADV INJURY	\$ 1,000,000
							GENERAL AGGREGATE	\$ 3,000,000
							PRODUCTS - COMP/OP AGG	\$ 3,000,000
								\$
A X	AUTOMOBILE LIABILITY ANY AUTO OWNED AUTOS ONLY <input checked="checked" type="checkbox"/> SCHEDULED AUTOS HIRED AUTOS ONLY <input type="checkbox"/> NON-OWNED AUTOS ONLY <input type="checkbox"/>			S2323596	6/1/2023	6/1/2024	COMBINED SINGLE LIMIT (Ea accident)	\$ 1,000,000
							BODILY INJURY (Per person)	\$
							BODILY INJURY (Per accident)	\$
							PROPERTY DAMAGE (Per accident)	\$
								\$
A X	UMBRELLA LIAB <input checked="checked" type="checkbox"/> EXCESS LIAB <input type="checkbox"/> CLAIMS-MADE			S2323596	6/1/2023	6/1/2024	EACH OCCURRENCE	\$ 3,000,000
	DED <input type="checkbox"/> RETENTION \$ <input type="checkbox"/>						AGGREGATE	\$ 3,000,000
								\$
B	WORKERS COMPENSATION AND EMPLOYERS' LIABILITY ANY PROPRIETOR/PARTNER/EXECUTIVE OFFICER/MEMBER EXCLUDED? <input type="checkbox"/> <b>(Mandatory in NH)</b> If yes, describe under DESCRIPTION OF OPERATIONS below		Y / N N / A	4069882	6/1/2023	6/1/2024	<input checked="checked" type="checkbox"/> PER STATUTE <input type="checkbox"/> OTHER	
							E.L. EACH ACCIDENT	\$ 1,000,000
							E.L. DISEASE - EA EMPLOYEE	\$ 1,000,000
							E.L. DISEASE - POLICY LIMIT	\$ 1,000,000

DESCRIPTION OF OPERATIONS / LOCATIONS / VEHICLES (ACORD 101, Additional Remarks Schedule, may be attached if more space is required)  
Project: **GJPD & City Hall Safety Bollard Installation**

<b>CERTIFICATE HOLDER</b>  City of Grand Junction Po Box 20000 Grand Junction, CO 81502	<b>CANCELLATION</b>  SHOULD ANY OF THE ABOVE DESCRIBED POLICIES BE CANCELLED BEFORE THE EXPIRATION DATE THEREOF, NOTICE WILL BE DELIVERED IN ACCORDANCE WITH THE POLICY PROVISIONS.
	<b>AUTHORIZED REPRESENTATIVE</b> 