

Emerson Skate Park



**Results of the conceptual design work for Emerson Park
Skatepark and Landscape site Plan RFP-5189-23-DD**

CITY OF
Grand Junction
COLORADO

TEAM PAIN

SKATE PARKS

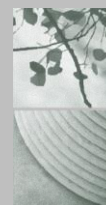

CLAUSON RAWLEY ASSOCIATES INC
landscape architecture. planning. resort design

TABLE OF CONTENTS

- Page 2 Table of contents
- Page 3 Summary of Project
- Page 4 Tree Study
- Pages 5 – 39 Geotechnical Report
- Pages 40 – 46 Existing Conditions & Site Analysis
- Page 47 – 53 Amenities & Landscape Schematic
- Page 54 – 104 Design Meeting
- Page 105 – 149 Design Presentation Meeting
- Page 150 – 166 Council Presentation Meeting
- Page 167 – 177 Musco Lighting design
- Page 178 Final Budget Estimate

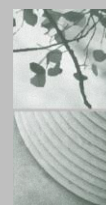

CLAUSON RAWLEY ASSOCIATES INC
landscape architecture . planning . resort design

Summary of Project

In February 2023, the City of Grand Junction issued a nationwide request for proposal on a conceptual design and landscape site plan at Emerson Park. Team Pain partnered with Clausen Rawley for this project. The RFP was awarded March 16, 2023 and we immediately began work.

Emerson Park is a 3.1 acres City park and one of the oldest in the City. The current playground and restroom facilities are dated and underused. The mature tree cover at the Emerson was determined to be vital and must be incorporated into the design of the skate park. Parking and access to the park needed to be addressed. Over the course of our design development, we also determined that the North and South corners of the park were a safety concern with cars accidentally crashing into the park.

The City's Tree Arborist performed a tree study to determine which trees were healthy enough to be included in the design. Minimal trees were identified as being sick or needing to be removed. This gave the Team our initial layout. The City also commissioned a geotechnical analysis of the ground conditions. The analysis determined the water table was favorable for construction of a skatepark.

A virtual public input meeting with the City, Design Team, and users was held on May 9, 2023. Team Pain developed a survey for the park users. We had 150 results from local users regarding what they wanted included in their skate park. Several breakout sessions were also held with leaders of the Grand Junction skate community. The design team used this information to develop our concept. We were able to place the skate park concept on the site without disturbing the mature tree canopy that provides natural shade. Clausen Rawley was able to mimic the serpentine seat walls used in the downtown corridor in the landscape design. This not only provides safety from cars entering the park, it also provides seating, while incorporating the aesthetic look from the downtown area into the park. Native and draught resistant plants were added. The benches, bike racks, trashcans, a metal portable toilet enclosure, and water fountains used in other City of Grand Junction parks were incorporated into the design so they correspond together seamlessly. Musco was able to develop a lighting plan with minimal poles that are dark sky compliant. Street parking along 10th street with a pedestrian lane was determined to have the least environmental impact while being the safest approach.

On July 27, 2023, the design team hosted a design reveal meeting to stakeholders and users. The response has been overwhelmingly positive! We complied our expected costs and presented to City Council Budget workshop on July 31, 2023 along with the conceptual design.

It has been a pleasure working for City of Grand Junction and we hope that this concept turns into a reality for the kids!

TREE PROTECTION ZONES

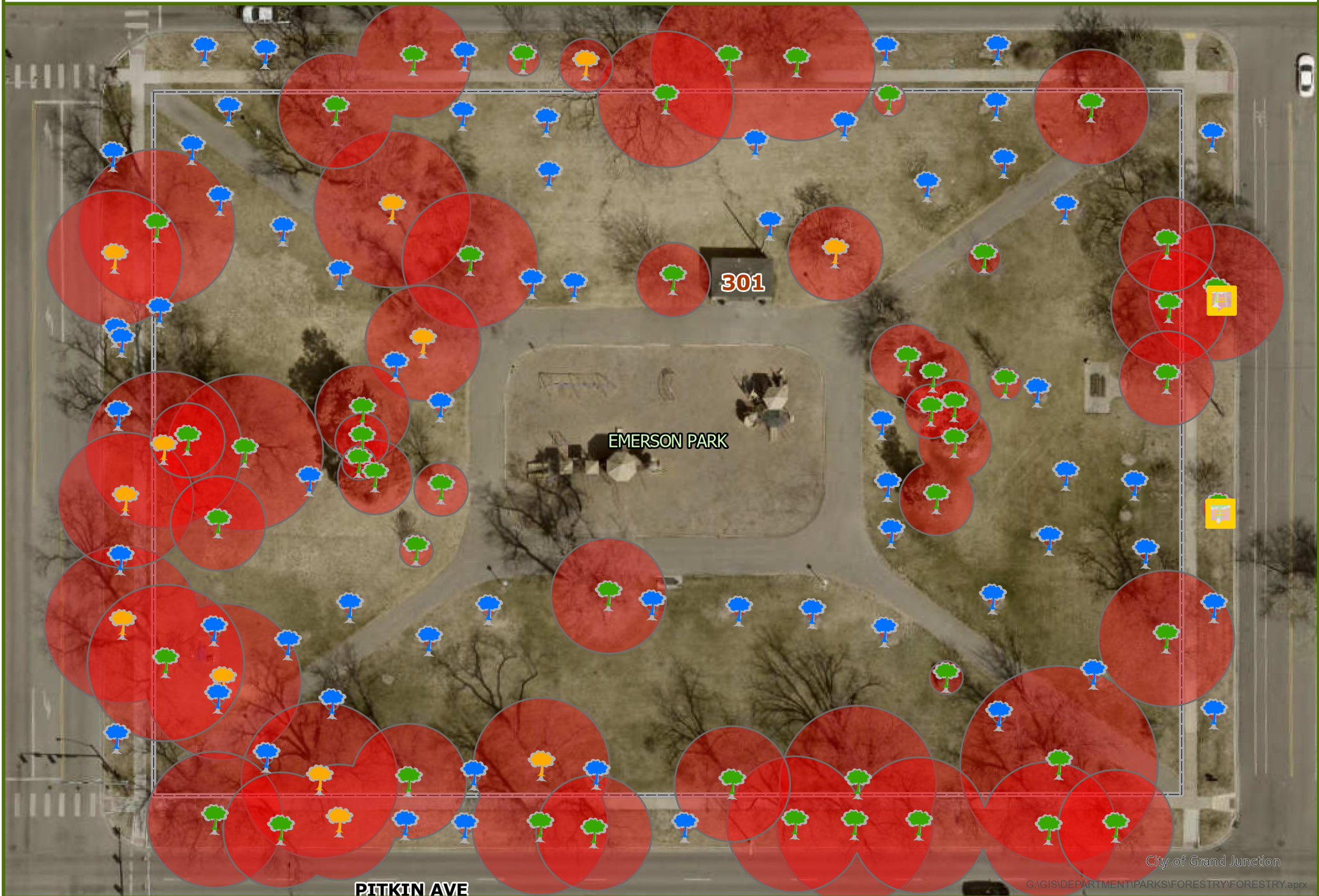

0 25 50 Feet



Good



Poor



1" - 4" DBH

Date Created: 3/24/2023

City of Grand Junction



G:\GIS\DEPARTMENT\PARKS\FORESTRY\FORESTRY.aprx

**Emerson Park Geotechnical and Parking Lot Pavement Design
City of Grand Junction, Colorado
Professional Geotechnical Services On-Call RFP-4739-20-DH
Contract Renewal Option #4887-23-DH**

**RockSol Project No. 599.77
July 14, 2023**



Prepared for:



**City of Grand Junction, Public Works
333 West Avenue, Bldg. C
Grand Junction, Colorado, 81501**

Attention: Kirsten Armbruster, PE

Prepared by:



**RockSol Consulting Group, Inc.
566 W Crete Circle #2
Grand Junction, Colorado, 81505
(970) 822-4350**

**Emerson Park Geotechnical and Parking Lot Pavement Design
City of Grand Junction, Colorado
Professional Geotechnical Services On-Call RFP-4739-20-DH
Contract Renewal Option #4887-23-DH**

RockSol Project No. 599.77

July 14, 2023

Prepared for:



**City of Grand Junction, Public Works
333 West Avenue, Bldg. C
Grand Junction, Colorado, 81501**

Attention: Kirsten Armbruster, PE

Prepared by:



**RockSol Consulting Group, Inc.
566 West Crete Circle, Suite #2
Grand Junction, Colorado, 81503**

(970) 822-4350

Ryan Lepro

Ryan Lepro
Engineering Geologist



Jay Goldbaum, P.E.
Senior Pavement Engineer



Donald G. Hunt, P.E.
Senior Engineer

Table of Contents

1.0	PROJECT PURPOSE AND DESCRIPTION.....	1
2.0	PROJECT LOCATION AND SITE CONDITIONS	1
3.0	SUBSURFACE EXPLORATION.....	2
4.0	LABORATORY TESTING.....	3
5.0	SURFACE AND SUBSURFACE CHARACTERIZATION.....	4
6.0	GEOLOGICAL SETTING.....	5
7.0	PAVEMENT DESIGN RECOMMENDATIONS	6
7.1	Traffic Loading (Parking Lot).....	6
7.2	Pavement Subgrade Characterization.....	6
7.3	Pavement Design Parameter Summary	6
7.4	Flexible Pavement Section Thickness Evaluation	7
7.5	Other Park Hard Surfacing Recommendations	7
8.0	SKATE PARK EARTHWORK DISCUSSION.....	7
9.0	GENERAL EARTHWORK	8
9.1	Compaction Specifications.....	8
9.2	Subgrade Preparation.....	8
10.0	OTHER DESIGN AND CONSTRUCTION CONSIDERATIONS.....	9
11.0	LIMITATIONS.....	9

ATTACHMENTS

Appendix A:	Legend and Individual Borehole Logs
Appendix B:	Laboratory Test Results
Appendix C:	PAVExpress Design Output Sheet (Flexible)

1.0 PROJECT PURPOSE AND DESCRIPTION

This report documents the geotechnical engineering investigation performed by RockSol Consulting Group, Inc. (RockSol) to assist the City of Grand Junction (City) with the design of a proposed parking lot and skate park improvements project at Emerson Park in Grand Junction, Colorado. The scope of work for this geotechnical investigation was presented in our proposal, dated April 5, 2023, and included preparing a subsurface investigation to collect subsurface soil samples for laboratory testing and evaluation.

The proposed Park improvements include a new paved parking area (approximately 10-12 parking stalls) with access from 10th Street, potential pedestrian pathway improvements, and a concrete-surfaced skate park with depressed bowls. The majority of parking improvements will be located on the east end of the park, with skate park improvements towards the center of the park. Improvements will be designed to minimize disturbance to the existing trees. A specialty design consultant will be assisting the City with design of the Skate Park amenities.

The subsurface investigation program was conducted to obtain geotechnical information on the subsurface soil, groundwater, and bedrock conditions at the Emerson Skate Park Project site. Surface and groundwater hydrology, hydraulic engineering, and environmental studies including contaminant characterization were not included in RockSol's geotechnical scope of work.

2.0 PROJECT LOCATION AND SITE CONDITIONS

The Emerson Skate Park Project area is located between south 9th Street and South 10th Street and between Ute Avenue and Pitkin Avenue (see Figure 1). Developments near or adjacent to the site include commercial and residential properties. Topography at the site generally consists of flat to mild slopes with decreasing elevation to the south.

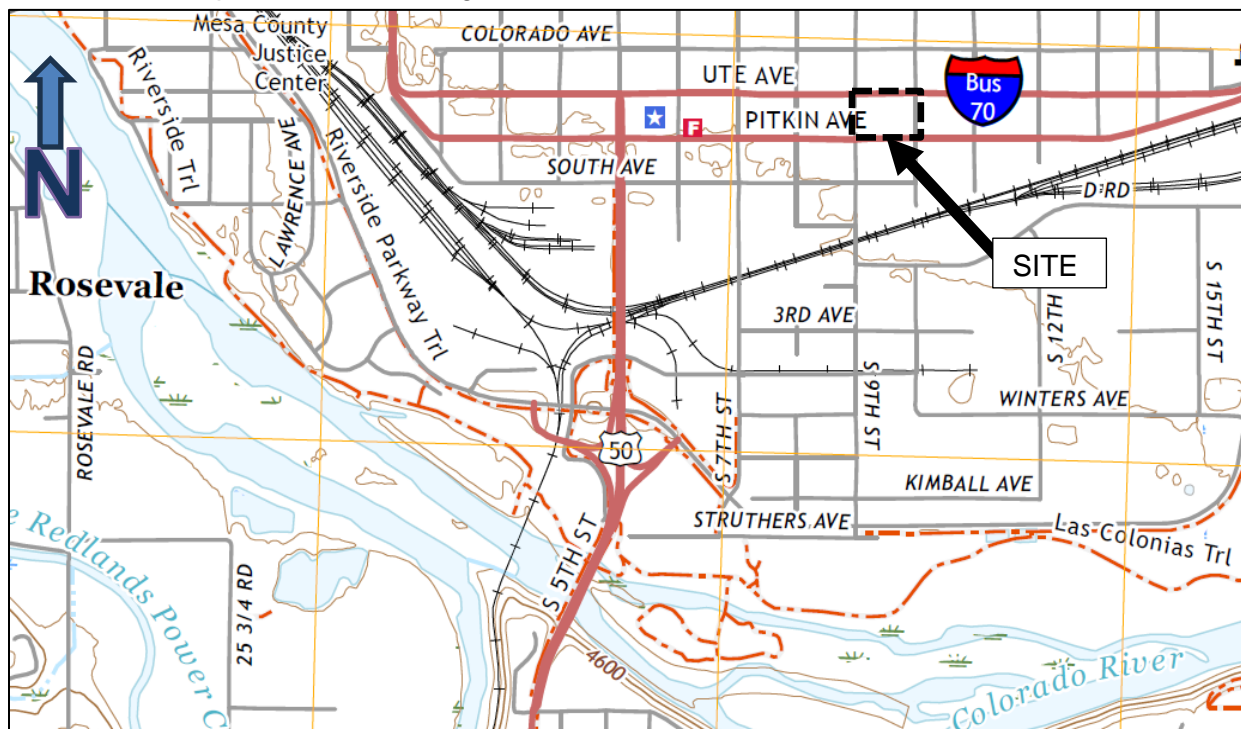

Figure 1 – Site Vicinity Map (USGS Topoview, 2022)

3.0 SUBSURFACE EXPLORATION

On May 30, 2023, RockSol advanced three vertically oriented boreholes to evaluate subsurface conditions at the project site. The borehole locations are identified as B-1 through B-3 as shown in Figure 2, Borehole Location Plan. A truck mounted Simco 2800 drill rig was used for drilling and sampling. The boreholes were advanced using 4-inch outside diameter solid stem auger to a maximum depth of 10 feet (Borehole B-1) and 15 feet (Boreholes B-2 and B-3) below existing grades. The boreholes were logged in the field by a representative of RockSol. Two boreholes (B-1 and B-3) were backfilled with auger cuttings and pea gravel material at the completion of drilling and groundwater level checks. A temporary piezometer was installed at Borehole B-2 and was left open temporarily to monitor groundwater elevation after completion of the borehole.

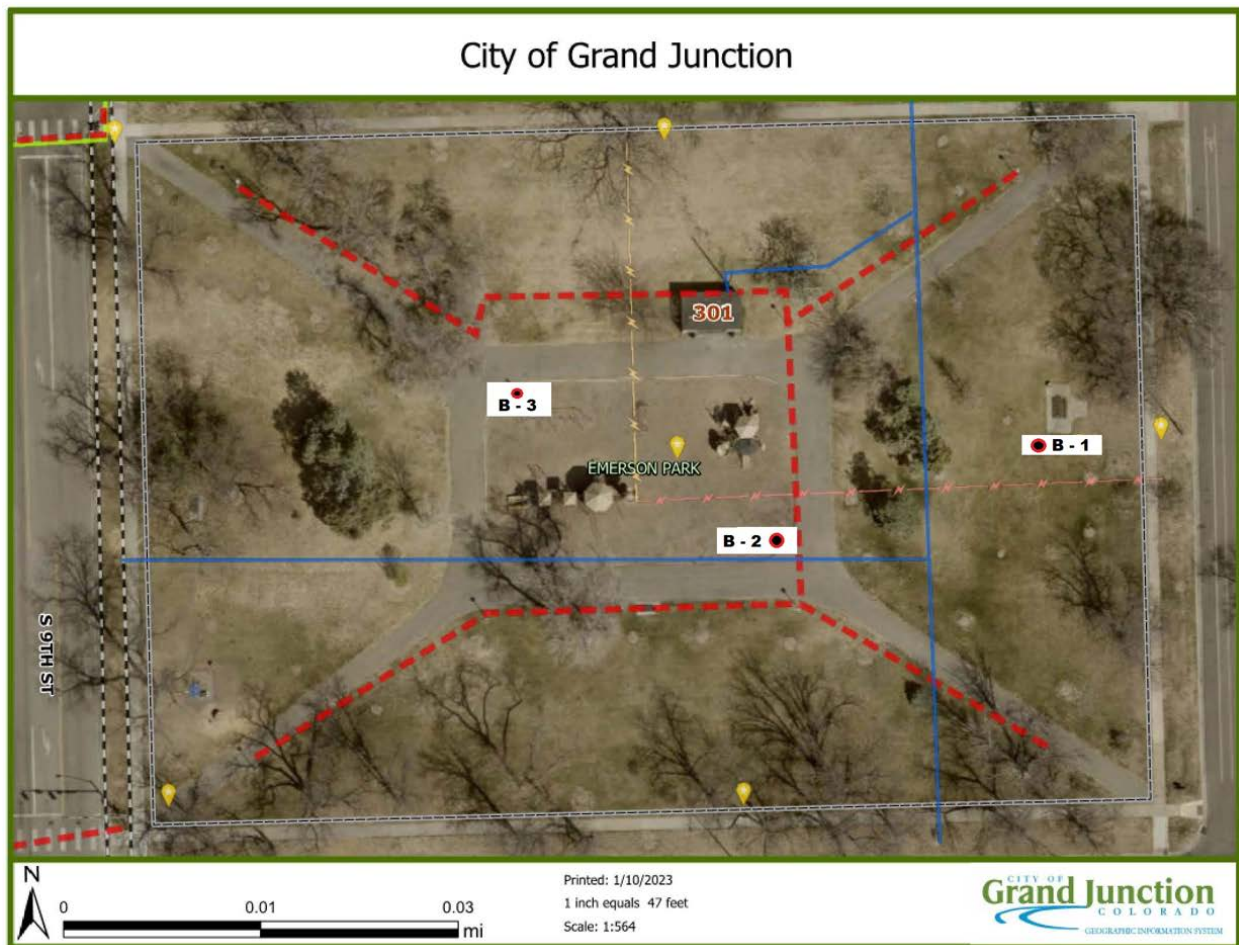

Figure 2 – Borehole Location Plan

Subsurface materials were sampled and resistance of the soil to penetration of the sampler was performed using modified California barrel and standard split spoon samplers. The modified California barrel sampler has an outside diameter of approximately 2.5 inches and an inside diameter of 2 inches. The standard split spoon sampler used had an outside diameter of 2 inches and an inside diameter of 1³/₈-inches. Brass tube liners were used with the modified California barrel sampler. Brass tube liners are not used with the standard split spoon sampler.

Penetration Tests were performed at selected intervals using an automatic hammer lift system. The standard split spoon sampling method is the Standard Penetration Test (SPT) described by

ASTM Method D-1586. Penetration Tests were performed using the modified California barrel sampler with a standard hammer weighing 140 pounds falling 30 inches per ASTM D3550. The modified California Barrel sampling method is similar to the SPT test with the difference being the sampler dimensions and the number of 6-inch intervals driven with the hammer. It is RockSol's experience that blow counts obtained with the modified California sampler tend to be slightly greater than a standard split spoon sampler. Penetration resistance values (blow counts) were recorded for each sampling event. Blow counts, when properly evaluated, indicate the relative density or consistency of the soils. The borehole were logged in general accordance of ASTM D2488.

Depths at which the samples were taken, the type of sampler used, and the blow counts that were obtained are shown on the Boring Logs for each borehole. Individual Borehole Logs are included in Appendix A.

Following borehole drilling and sampling operations, a piezometer pipe consisting of 1-inch-diameter Schedule 40 PVC slotted casing was installed in Borehole B-2 to the maximum depth drilled. Sand filter material for the piezometer was placed from the bottom of the borehole to approximately 1 foot below the ground surface on the outside of the pipe. Native clay soil was placed around the piezometer within the upper 1 foot of the ground surface to reduce the infiltration potential of precipitation. After subsequent groundwater depths were measured, the piezometer pipe was removed, and the borehole backfilled.

4.0 LABORATORY TESTING

Soil samples retrieved from the boreholes were reviewed by the project geotechnical engineer and selected samples were tested and classified according to the Unified Soil Classification System (USCS) and American Association of State Highway and Transportation Officials (AASHTO) classification systems. The following laboratory tests were performed in accordance with the American Society for Testing and Materials (ASTM), AASHTO, and current local practices:

- Natural Moisture Content (ASTM D-2216)
- Percent Passing No. 200 Sieve (ASTM D-1140)
- Liquid and Plastic Limits (ASTM D-4318)
- Dry Density (ASTM D-2937)
- Gradation (ASTM D 6913)
- Water-Soluble Sulfates (CDOT CP-L 2103)
- Soil Resistivity (ASTM G187 - Soil Box)
- Soil Classification (ASTM D-2487 and AASHTO M145)
- Swell Test (Denver Swell Test, modified from ASTM D-4546)
- Resistance Value (R-Value, AASHTO T190)

Laboratory test results were used to characterize the engineering properties of the subsurface material. For soil classification, RockSol conducted sieve analyses and Atterberg Limits tests. Lab testing was also performed on selected samples to determine the water-soluble sulfate content of subsurface materials to assist with cement type recommendations. All laboratory tests were performed by RockSol. Laboratory test results are presented in Appendix B and are also summarized on the Borehole Logs presented in Appendix A.

5.0 SURFACE AND SUBSURFACE CHARACTERIZATION

Surface conditions generally consist of 3 inches of sandy clay topsoil (Borehole B-1) and 3 inches of playground wood chip bedding (Boreholes B-2 and B-3) overlying native soils.

At Borehole B-1, stiff to very stiff and moist to very moist clay was encountered below the topsoil and extended to the maximum depth explored of 10 feet. At Borehole B-2, stiff clay that was moist to wet was encountered below the playground chips to a depth of 12 feet where wet, medium stiff, sandy to silty clay was encountered to the maximum depth explored, 15 feet. At Borehole B-3, stiff to medium stiff clay that was moist to very moist was encountered below the playground chips to a depth of 12 feet where wet, soft, sandy to silty clay was encountered to the maximum depth explored, 15.5 feet.

RockSol did not encounter cobble or boulder size material to the maximum depths explored, approximately 10 feet to 15.5 feet below existing grades. Bedrock was not encountered to the maximum depths drilled, approximately 10 feet to 15 feet below existing grades. Based on the materials encountered and the geologic setting described in Section 6.0, cobble or boulder-sized material is not anticipated to be encountered within 15 feet of the ground surface at this site.

Groundwater was noted at approximate depths of 9.3 to 9.5 feet below existing grades at Boreholes B-2 and B-3 during drilling operations. When checked one day after completion of the borehole, groundwater was observed at a depth of 10.5 feet in Borehole B-3. A temporary piezometer pipe was placed at Borehole B-2 to obtain subsequent groundwater measurements at that location. The piezometer was removed/abandoned on June 26, 2023. A summary of short-term groundwater levels can be found in Table 1.

Table 1: Approximate Ground Surface and Groundwater Elevations

Borehole	Ground Surface Elevation (ft)	Depth To Groundwater (ft)	Groundwater Elevation (ft)	Maximum Depth Drilled
B-1	4586.7	Not Observed	----	10.0
B-2	4584.8	10.9 (Note 1)	4573.9	15.0
B-3	4584.5	10.5 (Note 2)	4574.0	15.5

Note 1: Measured on June 26, 2023

Note 2: Measured on May 31, 2023

Descriptions of the surface and subsurface conditions encountered in the boreholes are summarized on the Borehole Logs presented in Appendix A. A summary of laboratory test results, with soil classifications, is presented in Appendix B.

Swell/Consolidation Potential of Subgrade Soils

Based on swell test results, subgrade soils with low to moderate expansive potential have been identified within the project limits. Swell tests were performed on selected samples obtained from the boreholes at approximate depths of 2 feet to 9 feet below existing grades. The swell/consolidation tests indicated a swell/collapse potential ranging from -0.1 percent (consolidation) to 4.8 percent (swell), when tested with 200 pound per square foot (psf) and 500-psf surcharge pressures. Swell mitigation is not deemed necessary provided subgrade preparation recommendations presented Section 9.2 of this report are properly followed during construction.

Sulfate Resistance Discussion

Cementitious material requirements for concrete in contact with site soils or groundwater are based on the percentage of water-soluble sulfate in either soil or groundwater that will be in

contact with concrete constructed for this project. Mix design requirements for concrete exposed to water soluble sulfates in soils or water is shown in Table 2: Concrete Sulfate, and in the Standard Specifications for Road and Bridge Construction, dated 2022 (from CDOT Table 601-2).

Table 2: Concrete Sulfate Exposure Class

Water-Soluble Sulfate (SO ₄) in Dry Soil, (%)	Sulfate (SO ₄) In Water, ppm	Cementitious Material Requirements
0.00 to 0.10	0 to 150	Class 0
0.11 to 0.20	151 to 1,500	Class 1
0.21 to 2.0	1,500 to 10,000	Class 2
2.01 or greater	10,001 or greater	Class 3

The concentration of water-soluble sulfates (percent by weight) measured in soil samples obtained in the upper 4 to 15 feet from RockSol’s exploratory boreholes ranged from 0.27 to 1.53 percent. Based on the results of the water-soluble sulfate testing, **Class 2** cementitious material mix design requirements for concrete exposed to water soluble sulfates in soils is recommended. Refer to CDOT’s current *Standard Specifications for Road and Bridge Construction Section 601* for concrete mixtures that satisfy appropriate sulfate exposure *Class* requirements.

6.0 GEOLOGICAL SETTING

Based on information presented in the *Geologic map of the Grand Junction quadrangle, Mesa County, Colorado* by Scott, R.B., Carrara, P.E., Hood, W.C., and Murray, K.E., U.S. Geological Survey, *Miscellaneous Field Studies Map MF-2363, Publication Date: 2002*, (See Figure 3 – Site Geology Map), the project site is underlain by Alluvium and colluvium (Qac), undivided (Holocene and late Pleistocene) which is generally made up of a mix of alluvium, sheetwash, and debris flow deposits consisting of sandy silt and clayey silt with shale and sandstone pebbles derived from the Mancos Shale (Km). Mancos Shale is identified at or near the surface approximately 1 mile south of the project site on the southern bank of the Colorado River. Mancos Shale was not encountered to the depths explored for this investigation.

Figure 3 – Site Geology Map (USGS, 2002)

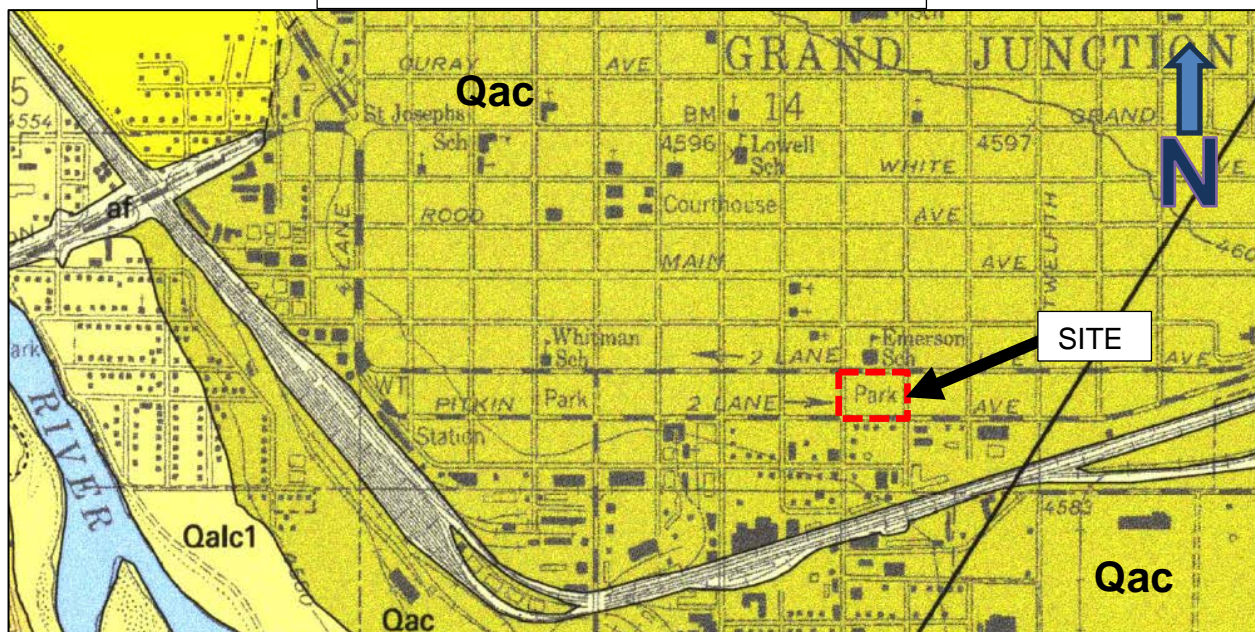

7.0 PAVEMENT DESIGN RECOMMENDATIONS

Park improvements will include the construction of a new paved parking lot on the east side of the Park. CDOT Mechanistic- Empirical (M-E) Pavement Design Methodology is not applicable to parking lot pavement design, so RockSol has prepared pavement design recommendations using the Colorado Asphalt Pavement Association’s manual entitled “A Guideline for the Design and Construction of Asphalt Parking Lots in Colorado” dated January 2006, which recommends the use of PAVExpress software that uses AASHTO 1993 methodology, and the output result can be found in Appendix C.

7.1 Traffic Loading (Parking Lot)

Primary vehicle usage of the proposed parking lot will be passenger cars with infrequent light-duty trucks. For pavement design purposes, RockSol recommends the use of 18,000-pound Equivalent Axle Loads (18-kip ESALs) of 20,000 for a 30-year design life in accordance with Subsection 29.32.030 of the City of Grand Junction Transportation Engineering Design Standards (TEDS) for the approximate 10 space parking facility.

7.2 Pavement Subgrade Characterization

To assist with pavement design recommendations, RockSol obtained bulk samples of on-site soils within 8-feet of the existing ground surface at the borehole locations. Classification testing indicates that the subgrade soils generally consist of a plastic, CLAY soil with an AASHTO soil classification of A-6 with Group Indices ranging from 14 to 21.

To test the subgrade support characteristics, one R-Value laboratory test was performed on in accordance with American Association of State Highway Transportation Officials (AASHTO) T-190 on a combined sample of material obtained within the top 4 feet of the surface from Borehole B-1. An R-Value of 8 was obtained from the sample and is attached to this report in Appendix B. Based on R-Value testing, a conservative R-Value of 5 will be used for new pavement constructed on the existing site soils. In accordance with the Guideline for Design and Use of Asphalt Pavements for Colorado Roadways, published by the Colorado Asphalt Pavement Association dated January 2006, the R-Value of 5 converts to a resilient modulus of 3,035 psi and will be used for the HMA design procedures mentioned in Subsections 29.32.040 (a) of the City of Grand Junction Transportation Engineering Design Standards (TEDS).

7.3 Pavement Design Parameter Summary

A summary of the pavement design input parameters used to evaluate the pavement thickness requirements for the proposed parking lot are presented below.

Table 3: Pavement Design Parameters

Pavement Design Parameter	Value
30-Year Design Life ESAL's	20,000
Subgrade Resilient Modulus, M_R	3,035 psi
Serviceability Loss, (ΔPSI)	2.5
Overall Standard Deviation, S_o	0.44
Reliability, (R)	80%
Structural Coefficient of HMA	0.44
Structural Coefficient of ABC	0.12

7.4 Flexible Pavement Section Thickness Evaluation

A summary of the pavement section thickness obtained from PAVExpress and recommended by RockSol is presented in Table 4. A pavement design calculation sheet is presented in Appendix C for the parking lot area and entrance drive.

Table 4: Pavement Section Thickness Evaluation

Using On-Site Soils (R-Value of 5 used as Design Basis)		
Roadway	Design ESALs (30 year)	Recommended Section (inches)
Parking Lot (Stall Area)	20,000	4.0 (Asphalt Section) over 6.0 (Aggregate Base Course)
Parking Lot (Entrance Drive)		4.0 (Asphalt Section) over 6.0 (Aggregate Base Course)

The recommended pavement section is two two-inch thick lifts of CDOT’s Grading SX mix with 75 design gyrations using a PG 64-22 performance graded binder. The aggregate base course (ABC) layer should be a minimum of six inches of CDOT Class 6 material.

7.5 Other Park Hard Surfacing Recommendations

Interior Park hard surfacing improvements will be included for pedestrian walkways, maintenance vehicles and small trucks associated with Park events. The number of maintenance vehicles and event trucks is anticipated to be very low when considered on a daily average basis.

All pavement (rigid and flexible pavement/flat-work materials) subgrade shall be properly compacted prior to placement of pavement sections. See Section 9.0 for compaction requirements.

Concrete paving for pedestrian-only use should be a minimum of 6-inches thick and should be constructed with a CDOT Class B concrete mix as modified by Section 601 of the current City Grand Junction Standard Specification for Road and Bridge Construction.

Concrete unit pavers are suitable for this site provided they are set on bedding sand with underlying aggregate base course and a geotextile separator fabric for the interface between the aggregate base course and the subgrade soils.

8.0 SKATE PARK EARTHWORK DISCUSSION

The City will be working with a specialty consultant for design of the Skate Park components such as the ramps, bowls, concrete surfacing.

Construction and materials for the proposed skate park amenities shall follow the designer guidelines and recommendations. At a minimum, the compaction and subgrade preparation recommendations presented in Sections 9.1 and 9.2 of this report should be considered.

Groundwater was encountered at an approximate depth of 10.9 feet at this site. The subsurface soils encountered in our boreholes are primarily CLAY and based on the in-situ moisture contents the CLAY appears to be moist to very moist due to capillary rise of the underlying groundwater. The moisture contents measured suggest that the in-situ moisture content is at, or slightly above optimum moisture content compared to the standard proctor performed for this project. Percent saturation values of 90% to 98% were measured in the existing soils.

The in-situ density of the samples suggests that the “state of compaction” is generally at or above 95 percent of maximum dry density compared to the standard proctor value obtained and performed for this investigation.

The CLAY encountered at this site will deflect under the wheels/tires of heavy equipment or vehicles and repeated loading will result in significant deformation of the working surface of the soil. Lightweight equipment and methods are recommended for excavating and reworking the CLAY soils at this site.

9.0 GENERAL EARTHWORK

All earthwork shall be performed in accordance with Section 203 of the current City of Grand Junction Standard Specification for Road and Bridge Construction.

9.1 Compaction Specifications

A representative of the geotechnical engineer should observe and test fill placement operations. The minimum compaction recommendations are presented in Table 5 and are based on AASHTO soil classifications. The majority of the existing site soil falls into the A-6 group shown in Table 5.

Table 5: Compaction Specifications

AASHTO Classification (AASHTO M 145)	AASHTO T 99 (Standard Proctor) Relative Compaction (Minimum Percent)	AASHTO T180 (Modified Proctor) Relative Compaction (Minimum Percent)
A-1	100	95
A-3	100	95
A-2-4	100	95
A-2-5	100	95
A-2-6, A-3, A-4, A-6, A-7-5, and A-7-6	95	Not Applicable

9.2 Subgrade Preparation

Prior to embankment-related and parking lot construction, the underlying subgrade should be properly prepared by removal of all organic matter (topsoil), debris, loose material, and any deleterious material identified by the Project Engineer followed by scarification, moisture conditioning and recompaction. Unless otherwise required, the minimum depth of scarification, moisture conditioning and re-compaction shall be 6 inches and compacting to a minimum of 95 percent of maximum dry density (MDD) as determined by AASHTO T99 (standard proctor) and moisture conditioned to a range from 2 percent below optimum moisture content to 2 percent above optimum moisture content (OMC).

10.0 OTHER DESIGN AND CONSTRUCTION CONSIDERATIONS

Proper construction practices, in accordance with City of Grand Junction Transportation Engineering Design Standards, should be followed during site preparation, structure and earthwork excavations for the suitable long-term performance of the proposed improvements. Excavation support should be provided to maintain onsite safety and the stability of excavations and slopes. Excavations shall be constructed in accordance with local, state and federal regulations including OSHA guidelines. The contractor must provide a competent person to determine compliance with OSHA excavation requirements. For preliminary planning, existing fill material and native soils may be considered as OSHA Type C soils.

Surface drainage patterns may be altered during construction and local landscape irrigation (if any) must be controlled to prevent excessive moisture infiltration into the subgrade soils during and after construction.

Environmentally contaminated material, if encountered, should be characterized and removed under the direction of the project environmental consultant. Design and construction plans should be reviewed, and onsite construction should be observed by the professional engineers.

11.0 LIMITATIONS

This geotechnical investigation was conducted in general accordance with the scope of work. RockSol's geotechnical practices are similar to those used in Colorado with similar soil conditions and based on our understanding of the proposed work. This report has been prepared for use by the City of Grand Junction for the project described in this report. The report is based on our exploratory boreholes and does not consider variations in the subsurface conditions that may exist between boreholes. Additional investigation is required to address such variation. If during construction activities, materials or water conditions appear to be different from those described herein, RockSol should be advised at once so that a re-evaluation of the recommendations presented in this report can be made. RockSol is not responsible for liability associated with interpretation of subsurface data by others.

APPENDIX A

LEGEND AND INDIVIDUAL SOIL BOREHOLE LOGS

CLIENT City of Grand Junction

PROJECT NAME Emerson Park Geotechnical Investigation

PROJECT NUMBER 599.77

PROJECT LOCATION Grand Junction, Colorado

LITHOLOGY



TOPSOIL



Native - CLAY



Native - CLAY, sandy to silty



Playground Chips

SAMPLE TYPE



Auger Cuttings



**MODIFIED CALIFORNIA SAMPLER
2.5" O.D. AND 2" I.D.
WITH BRASS LINERS INCLUDED**



**SPLIT SPOON SAMPLER
2" O.D. AND 1 3/8" I.D.
NO LINERS**

Fines Content indicates amount of material, by weight, passing the US No 200 Sieve (%)





15/12 Indicates 15 blows of a 140 pound hammer falling 30 inches was required to drive the sampler 12 inches.

5,5,5 Indicates 5 blows, 5 blows, 5 blows of a 140 pound hammer falling 30 inches was required to drive the sampler 18 inches.

 **GROUND WATER LEVEL 1ST DEPTH**

 **GROUND WATER LEVEL 2ND DEPTH**

CLIENT City of Grand Junction **PROJECT NAME** Emerson Park Geotechnical Investigation
PROJECT NUMBER 599.77 **PROJECT LOCATION** Grand Junction, Colorado
DATE STARTED 5/30/23 **COMPLETED** 5/30/23 **EXISTING ELEVATION** 4586.7 ft **STATION NO.** _____
DRILLING CONTRACTOR Colorado Drilling and Sampling **NORTH** _____ **EAST** _____
DRILLING METHOD Solid Stem Auger **HOLE SIZE** 4.25" **BORING LOCATION:** East/middle area of park
LOGGED BY R. Lepro **HAMMER TYPE** Automatic **GROUND WATER LEVELS:** **1ST DEPTH** None Encountered on 5/30/23
NOTES _____ **2ND DEPTH** N. E. on 5/31/23 **3RD DEPTH** N. E. on 6/1/23

ELEVATION (ft)	DEPTH (ft)	GRAPHIC LOG	MATERIAL DESCRIPTION	SAMPLE TYPE NUMBER	BLOW COUNTS (N VALUE)	SWELL POTENTIAL (%)	SULFATE (%)	DRY UNIT WT. (pcf)	MOISTURE CONTENT (%)	ATTERBERG LIMITS			FINES CONTENT (%)
										LIQUID LIMIT	PLASTIC LIMIT	PLASTICITY INDEX	
4586.7	0.0		(Topsoil) CLAY, sandy, moist, brown, grass cover, approximately 3 inches thick										
			(Native) CLAY, moist, brown, stiff to very stiff, slightly calcareous										
			Approximate Bulk Depth 0.25-4 Liquid Limit= 39 Plastic Limit= 19 Plasticity Index= 20 Fines Content= 97.8 Sulfate= 0.70	B BULK			0.70			39	19	20	97.8
4584.2	2.5			MC	8/12	0.1		104.2	20.2				
				MC	11/12			106.5	19.3				
4581.7	5.0			MC									
				MC									
4579.2	7.5			MC	18/12	4.8		104.6	19.9				
4576.7	10.0		Bottom of hole at 10.0 feet.										

LOG - STANDARD - 2 H2O 599.77 EMERSON PARK GJ.GPJ 6/29/23

CLIENT City of Grand Junction **PROJECT NAME** Emerson Park Geotechnical Investigation
PROJECT NUMBER 599.77 **PROJECT LOCATION** Grand Junction, Colorado
DATE STARTED 5/30/23 **COMPLETED** 5/30/23 **EXISTING ELEVATION** 4584.8 ft **STATION NO.** _____
DRILLING CONTRACTOR Colorado Drilling and Sampling **NORTH** _____ **EAST** _____
DRILLING METHOD Solid Stem Auger **HOLE SIZE** 4.25" **BORING LOCATION:** SE corner of playground area
LOGGED BY R. Lepro **HAMMER TYPE** Automatic **GROUND WATER LEVELS:** ▼ **1ST DEPTH** 9.5 ft on 5/30/23
NOTES Temporary piezometer installed ▼ **2ND DEPTH** 10.8 ft on 5/31/23 ▼ **3RD DEPTH** 10.9 ft on 6/26/23

ELEVATION (ft)	DEPTH (ft)	GRAPHIC LOG	MATERIAL DESCRIPTION	SAMPLE TYPE NUMBER	BLOW COUNTS (N VALUE)	SWELL POTENTIAL (%)	SULFATE (%)	DRY UNIT WT. (pcf)	MOISTURE CONTENT (%)	ATTERBERG LIMITS			FINES CONTENT (%)
										LIQUID LIMIT	PLASTIC LIMIT	PLASTICITY INDEX	
4584.8	0.0		Playground Chips, approximately 3 inches thick (Native) CLAY, moist to wet, brown, stiff, slightly calcareous										
4582.3	2.5		Approximate Bulk Depth 0.25-8 Liquid Limit= 30 Plastic Limit= 15 Plasticity Index= 15 Fines Content= 98.6 Sulfate= 0.27	MC	9/12	2.6		100.1	23.4				
				B BULK									
4579.8	5.0			MC	9/12	1.3	0.27	97.9	25.2	30	15	15	98.6
4577.3	7.5												
4574.8	10.0			MC	13/12	1.4	0.94	102.7	22.3				
4572.3	12.5		(Native) CLAY, sandy to silty, wet, brown, medium stiff	B BULK			0.88			29	14	15	93.1
			Approximate Bulk Depth 9-15 Liquid Limit= 29 Plastic Limit= 14 Plasticity Index= 15 Fines Content= 93.1 Sulfate= 0.88										
4569.8	15.0			MC	6/12								
			Bottom of hole at 15.0 feet.										

LOG - STANDARD - 2 H2O 599.77 EMERSON PARK GJ.GPJ 6/29/23

CLIENT City of Grand Junction **PROJECT NAME** Emerson Park Geotechnical Investigation
PROJECT NUMBER 599.77 **PROJECT LOCATION** Grand Junction, Colorado
DATE STARTED 5/30/23 **COMPLETED** 5/30/23 **EXISTING ELEVATION** 4584.6 ft **STATION NO.** _____
DRILLING CONTRACTOR Colorado Drilling and Sampling **NORTH** _____ **EAST** _____
DRILLING METHOD Solid Stem Auger **HOLE SIZE** 4.25" **BORING LOCATION:** NW corner of playground area
LOGGED BY R. Lepro **HAMMER TYPE** Automatic **GROUND WATER LEVELS:** ▼ **1ST DEPTH** 9.3 ft on 5/30/23
NOTES _____ ▼ **2ND DEPTH** 10.5 ft on 5/31/23

ELEVATION (ft)	DEPTH (ft)	GRAPHIC LOG	MATERIAL DESCRIPTION	SAMPLE TYPE NUMBER	BLOW COUNTS (N VALUE)	SWELL POTENTIAL (%)	SULFATE (%)	DRY UNIT WT. (pcf)	MOISTURE CONTENT (%)	ATTERBERG LIMITS			FINES CONTENT (%)
										LIQUID LIMIT	PLASTIC LIMIT	PLASTICITY INDEX	
4584.6	0.0		Playground Chips, approximately 3 inches thick (Native) CLAY, slightly silty, moist to very moist, brown, stiff to medium stiff, slightly calcareous										
4582.1	2.5		Approximate Bulk Depth 0.25-6 Liquid Limit= 38 Plastic Limit= 19 Plasticity Index= 19 Fines Content= 97.3	MC	12/12	1.3		108.7	18.8				
				B BULK						38	19	19	97.3
4579.6	5.0			MC	8/12	-0.1		102.8	22.0				
4577.1	7.5												
4574.6	10.0			MC	12/12	0.9	1.53	106.3	20.6				
4572.1	12.5		(Native) CLAY, sandy to silty, wet, brown, soft Approximate Bulk Depth 9-15 Liquid Limit= 28 Plastic Limit= 16 Plasticity Index= 12 Fines Content= 75.8	B BULK			1.04			28	16	12	75.8
4569.6	15.0			SS	1/1/2					18	14	4	61.5
			Bottom of hole at 15.5 feet.										

LOG - STANDARD - 2 H2O 599.77 EMERSON PARK GJ.GPJ 6/29/23

APPENDIX B

LABORATORY TEST RESULT SUMMARY

AND

TEST RESULT SHEETS



SUMMARY OF PHYSICAL & CHEMICAL TEST RESULTS

CLIENT City of Grand Junction

PROJECT NAME Emerson Park Geotechnical Investigation

PROJECT NUMBER 599.77

PROJECT LOCATION Grand Junction, Colorado

Borehole	Depth (ft)	Liquid Limit	Plastic Limit	Plasticity Index	Swell Potential (%)	% <#200 Sieve	Classification		Water Content (%)	Dry Density (pcf)	Unconfined Compressive Strength (psi)	Sulfate (%)	Resistivity (ohm-cm)	pH	Chlorides (%)	Proctor		
							USCS	AASHTO								S=Standard	M=Modified	MDD
B-1	0.25-4	39	19	20		98	CL	A-6 (21)				0.70						
B-1	2				0.1				20.2	104.2								
B-1	4								19.3	106.5								
B-1	9				4.8				19.9	104.6								
B-2	0.25-8	30	15	15		99	CL	A-6 (14)				0.27				106.2	19.0	S
B-2	2				2.6				23.4	100.1								
B-2	4				1.3				25.2	97.9								
B-2	9-15	29	14	15		93	CL	A-6 (12)				0.88						
B-2	9.01				1.4				22.3	102.7		0.94						
B-3	0.25-6	38	19	19		97	CL	A-6 (19)										
B-3	2				1.3				18.8	108.7								
B-3	4				-0.1				22.0	102.8								
B-3	9-15	28	16	12		76	CL	A-6 (7)				1.04						
B-3	9.01				0.9				20.6	106.3		1.53						
B-3	14	18	14	4		62	CL-ML	A-4 (0)										

SUMMARY-STANDARD LANDSCAPE CDOT SPACING 599.77 EMERSON PARK GJ.GPJ 6/20/23

CLIENT City of Grand Junction
PROJECT NUMBER 599.77

PROJECT NAME Emerson Park Geotechnical Investigation
PROJECT LOCATION Grand Junction, Colorado

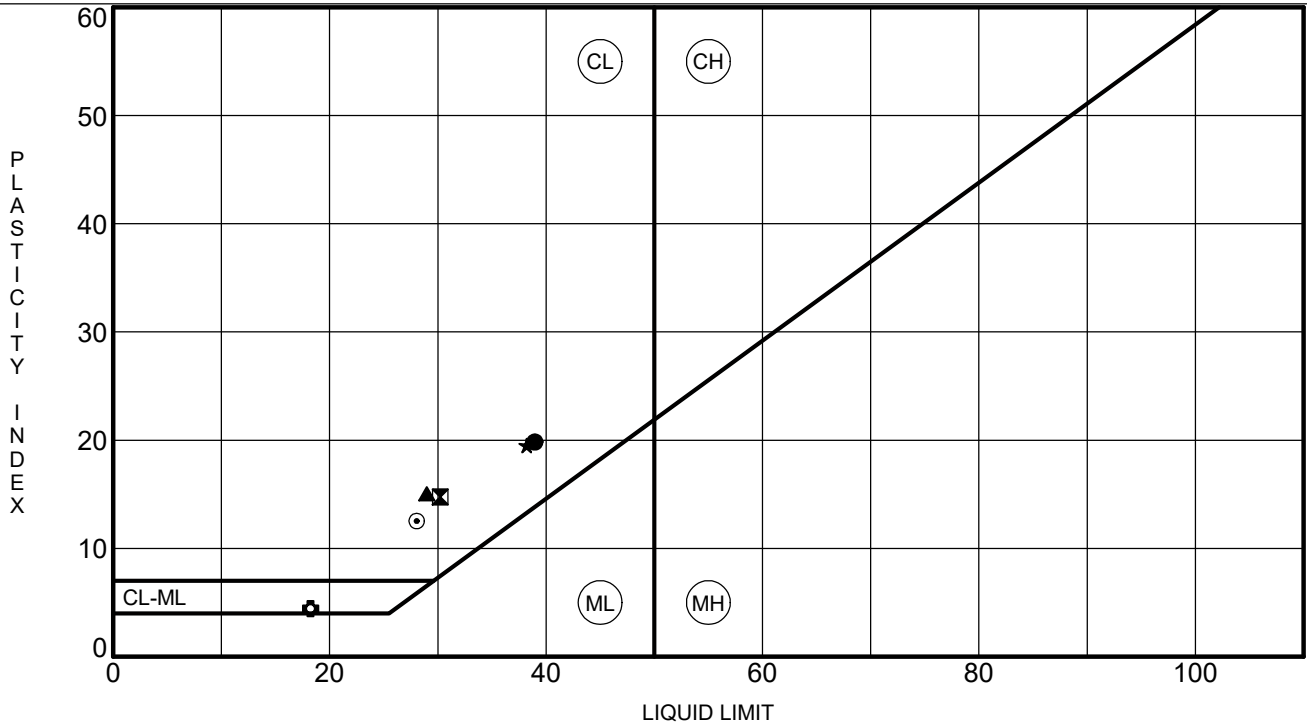

Specimen Identification	LL	PL	PI	Fines	Classification
● B-1 0.3-4.0	39	19	20	97.8	LEAN CLAY (CL) (A-6)
⊠ B-2 0.3-8.0	30	15	15	98.6	LEAN CLAY (CL) (A-6)
▲ B-2 9.0-15.0	29	14	15	93.1	LEAN CLAY (CL) (A-6)
★ B-3 0.3-6.0	38	19	19	97.3	LEAN CLAY (CL) (A-6)
⊙ B-3 9.0-15.0	28	16	12	75.8	LEAN CLAY with SAND (CL) (A-6)
⊕ B-3 14.0	18	14	4	61.5	SANDY SILTY CLAY (CL-ML) (A-4)

CLIENT City of Grand Junction

PROJECT NAME Emerson Park Geotechnical Investigation

PROJECT NUMBER 599.77

PROJECT LOCATION Grand Junction, Colorado

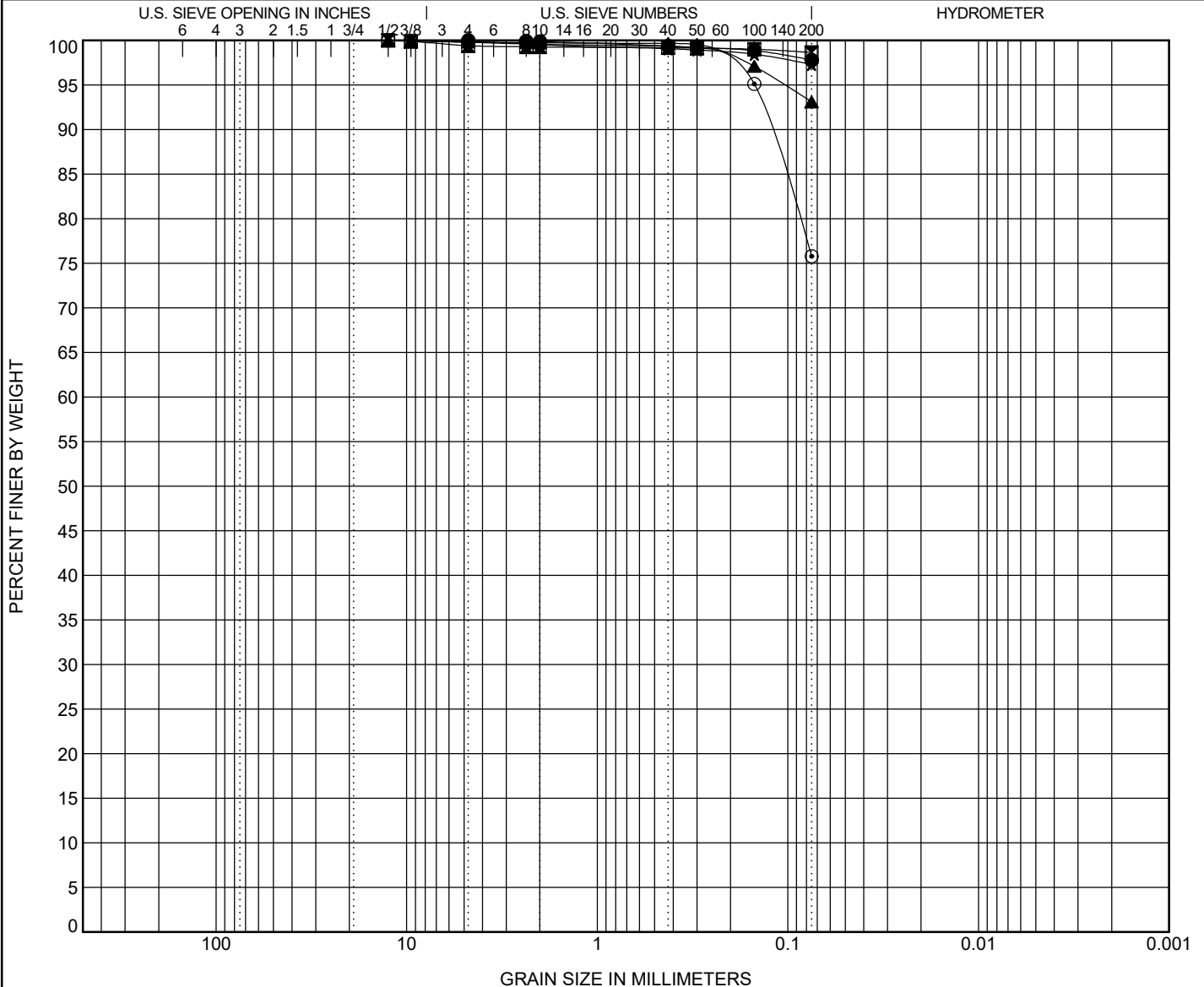

COBBLES	GRAVEL		SAND			SILT OR CLAY
	coarse	fine	coarse	medium	fine	

Specimen Identification	Classification	LL	PL	PI	Cc	Cu			
● B-1 0.3-4.0	LEAN CLAY (CL) (A-6)	39	19	20					
☒ B-2 0.3-8.0	LEAN CLAY (CL) (A-6)	30	15	15					
▲ B-2 9.0-15.0	LEAN CLAY (CL) (A-6)	29	14	15					
★ B-3 0.3-6.0	LEAN CLAY (CL) (A-6)	38	19	19					
◎ B-3 9.0-15.0	LEAN CLAY with SAND (CL) (A-6)	28	16	12					
Specimen Identification	D100	D60	D30	D10	%Gravel	%Coarse Sand	%Fine Sand	%Silt	%Clay
● B-1 0.3-4.0	4.75				0.1	0.5	1.6		97.8
☒ B-2 0.3-8.0	12.5				0.7	0.1	0.5		98.6
▲ B-2 9.0-15.0	12.5				0.3	0.1	6.6		93.1
★ B-3 0.3-6.0	9.5				0.5	0.5	1.8		97.3
◎ B-3 9.0-15.0	12.5				0.5	0.2	23.6		75.8

CLIENT City of Grand Junction

PROJECT NAME Emerson Park Geotechnical Investigation

PROJECT NUMBER 599.77

PROJECT LOCATION Grand Junction, Colorado

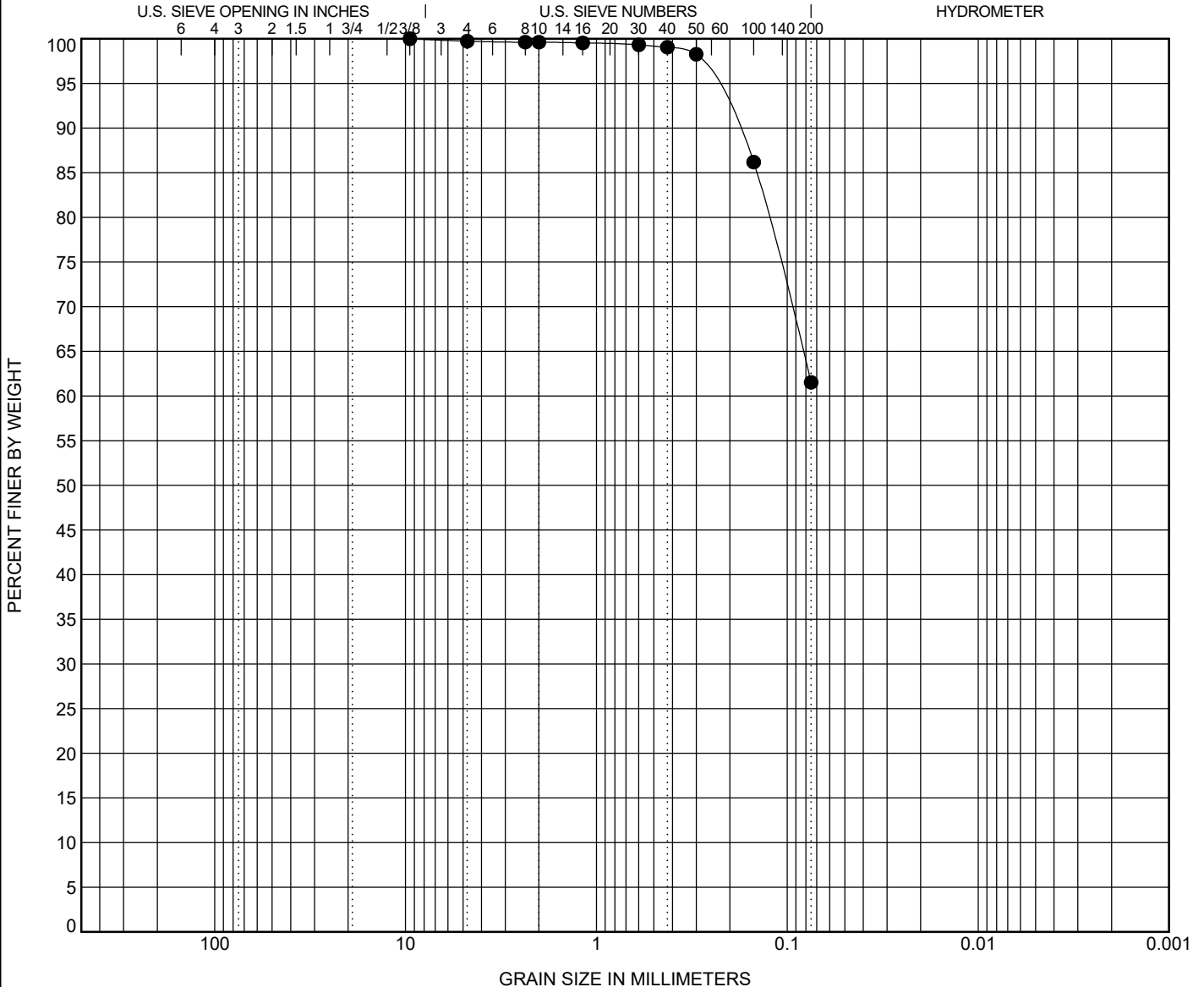

COBBLES	GRAVEL		SAND			SILT OR CLAY
	coarse	fine	coarse	medium	fine	

Specimen Identification	Classification	LL	PL	PI	Cc	Cu
● B-3 14.0	SANDY SILTY CLAY (CL-ML) (A-4)	18	14	4		

Specimen Identification	D100	D60	D30	D10	%Gravel	%Coarse Sand	%Fine Sand	%Silt	%Clay
● B-3 14.0	9.5				0.4	0.6	37.5	61.5	

CLIENT City of Grand Junction

PROJECT NAME Emerson Park Geotechnical Investigation

ROCKSOL PROJECT NUMBER 599.77

CLIENT PROJECT NUMBER Grand Junction, Colorado

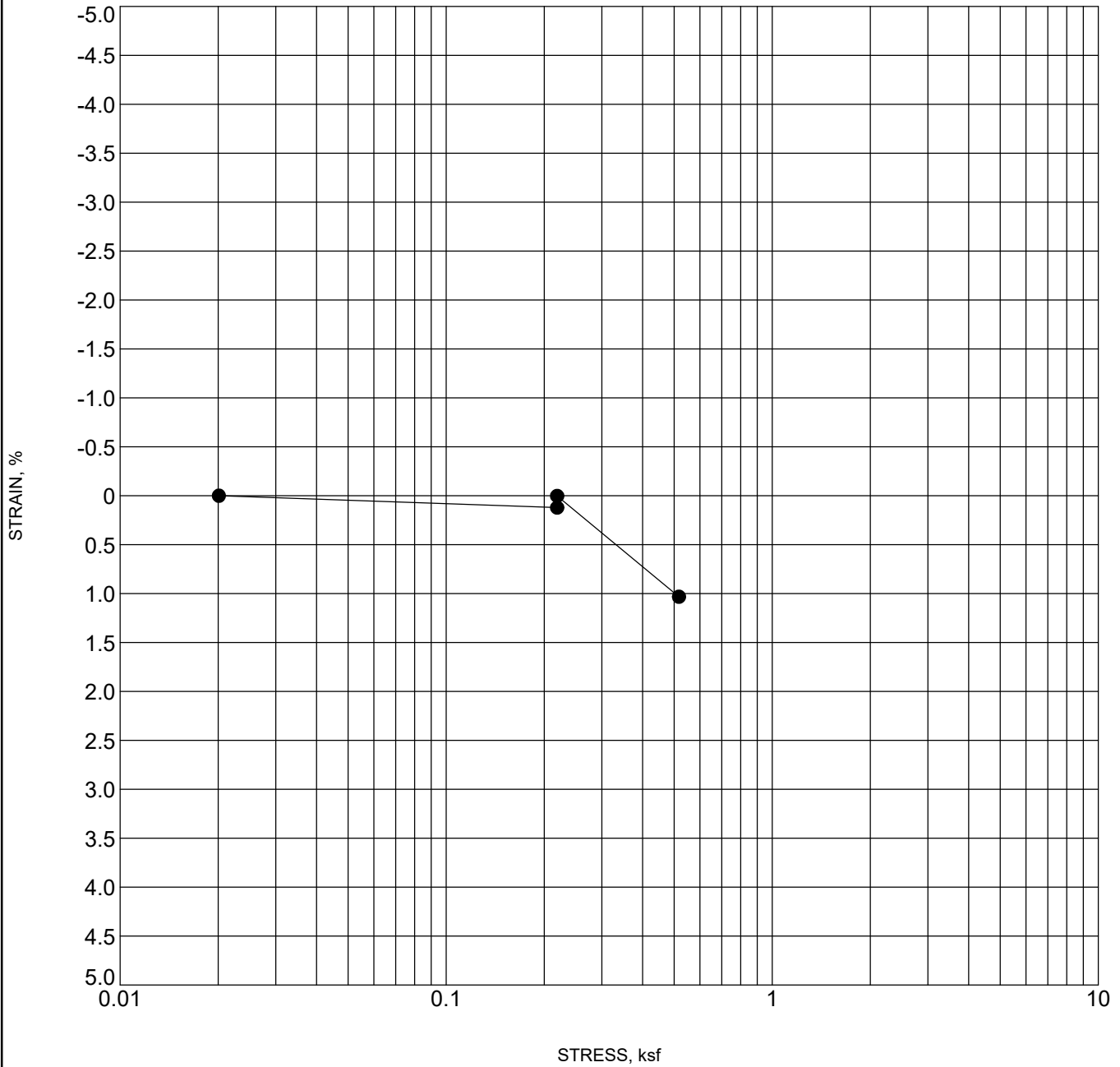

SWELL - CLIENT STANDARD 599.77_EMERSON PARK G.J.GPJ ROCKSOL TEMPLATE.GDT 6/29/23

Specimen Identification	Classification	Swell/Consol. (%)	γ_d (pcf)	MC%
● B-1 2	CLAY	0.1	104.2	20.2

CLIENT City of Grand Junction

PROJECT NAME Emerson Park Geotechnical Investigation

ROCKSOL PROJECT NUMBER 599.77

CLIENT PROJECT NUMBER Grand Junction, Colorado

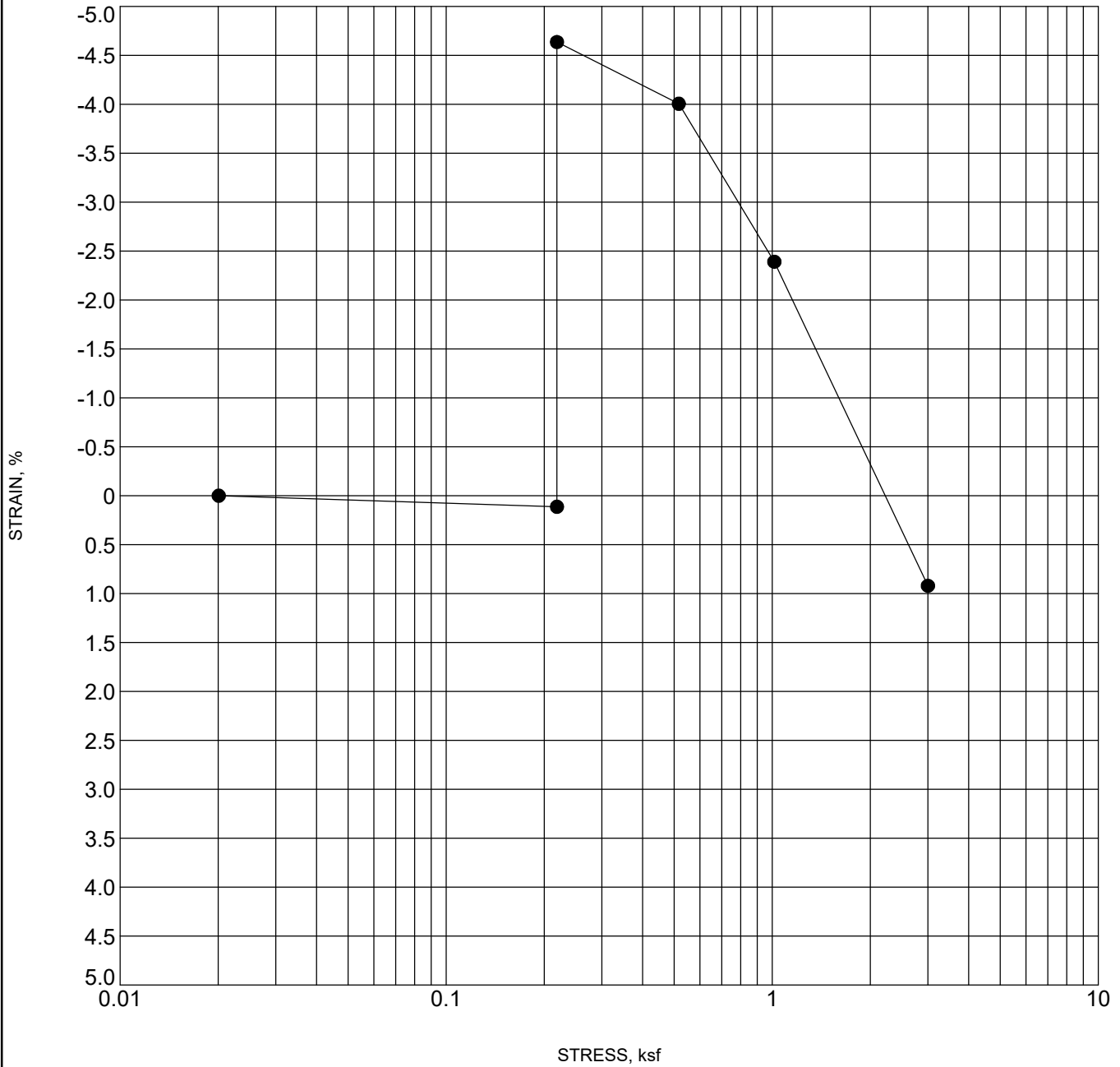

SWELL - CLIENT STANDARD 599.77_EMERSON PARK G.J.GPJ ROCKSOL TEMPLATE.GDT 6/29/23

Specimen Identification	Classification	Swell/Consol. (%)	γ_d (pcf)	MC%
● B-1 9	CLAY	4.8	104.6	19.9

CLIENT City of Grand Junction

PROJECT NAME Emerson Park Geotechnical Investigation

ROCKSOL PROJECT NUMBER 599.77

CLIENT PROJECT NUMBER Grand Junction, Colorado

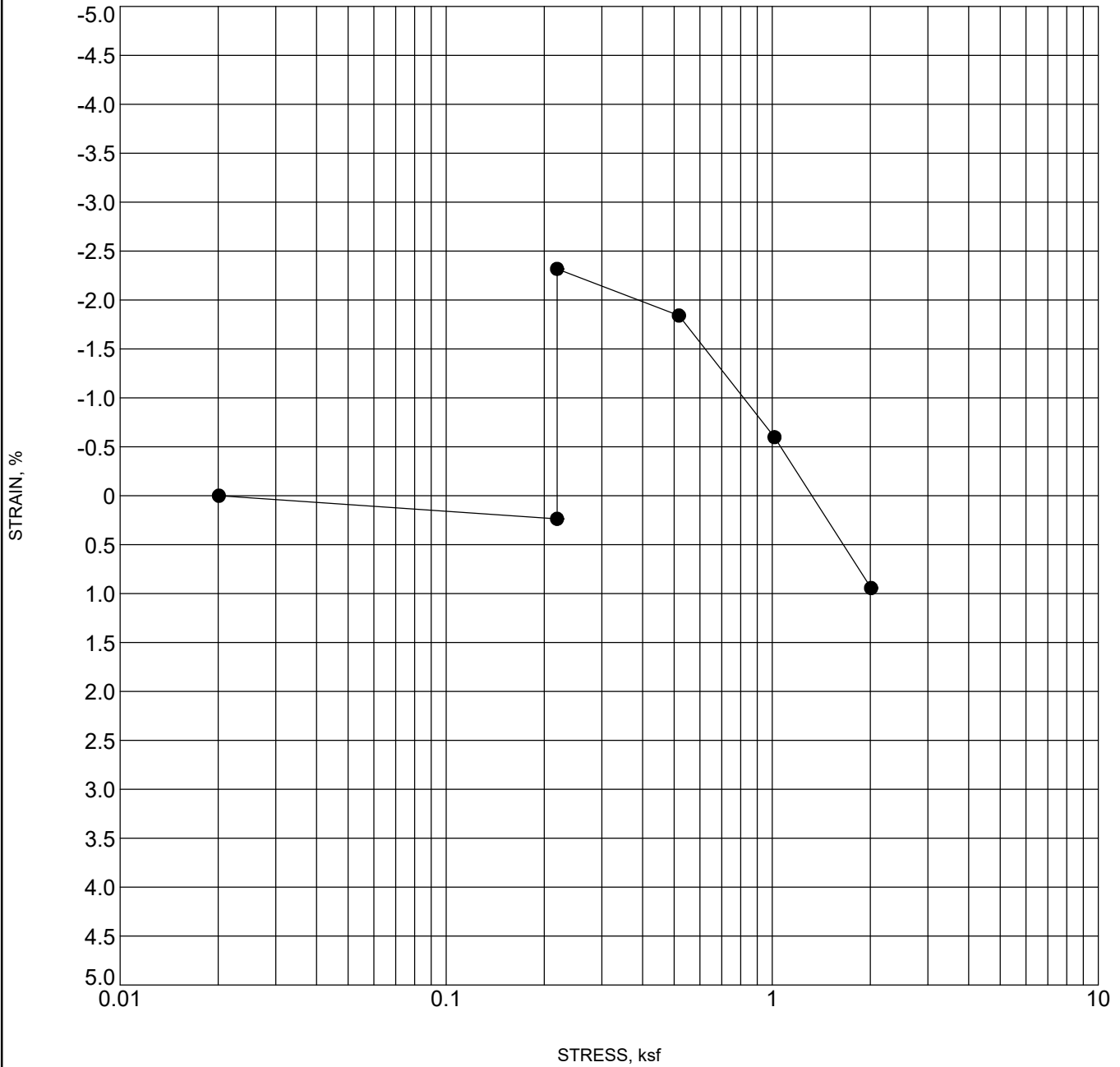

SWELL - CLIENT STANDARD 599.77_EMERSON PARK G.J.GPJ ROCKSOL TEMPLATE.GDT 6/29/23

Specimen Identification	Classification	Swell/Consol. (%)	γ_d (pcf)	MC%
● B-2 2	CLAY	2.6	100.1	23.4

CLIENT City of Grand Junction

PROJECT NAME Emerson Park Geotechnical Investigation

ROCKSOL PROJECT NUMBER 599.77

CLIENT PROJECT NUMBER Grand Junction, Colorado

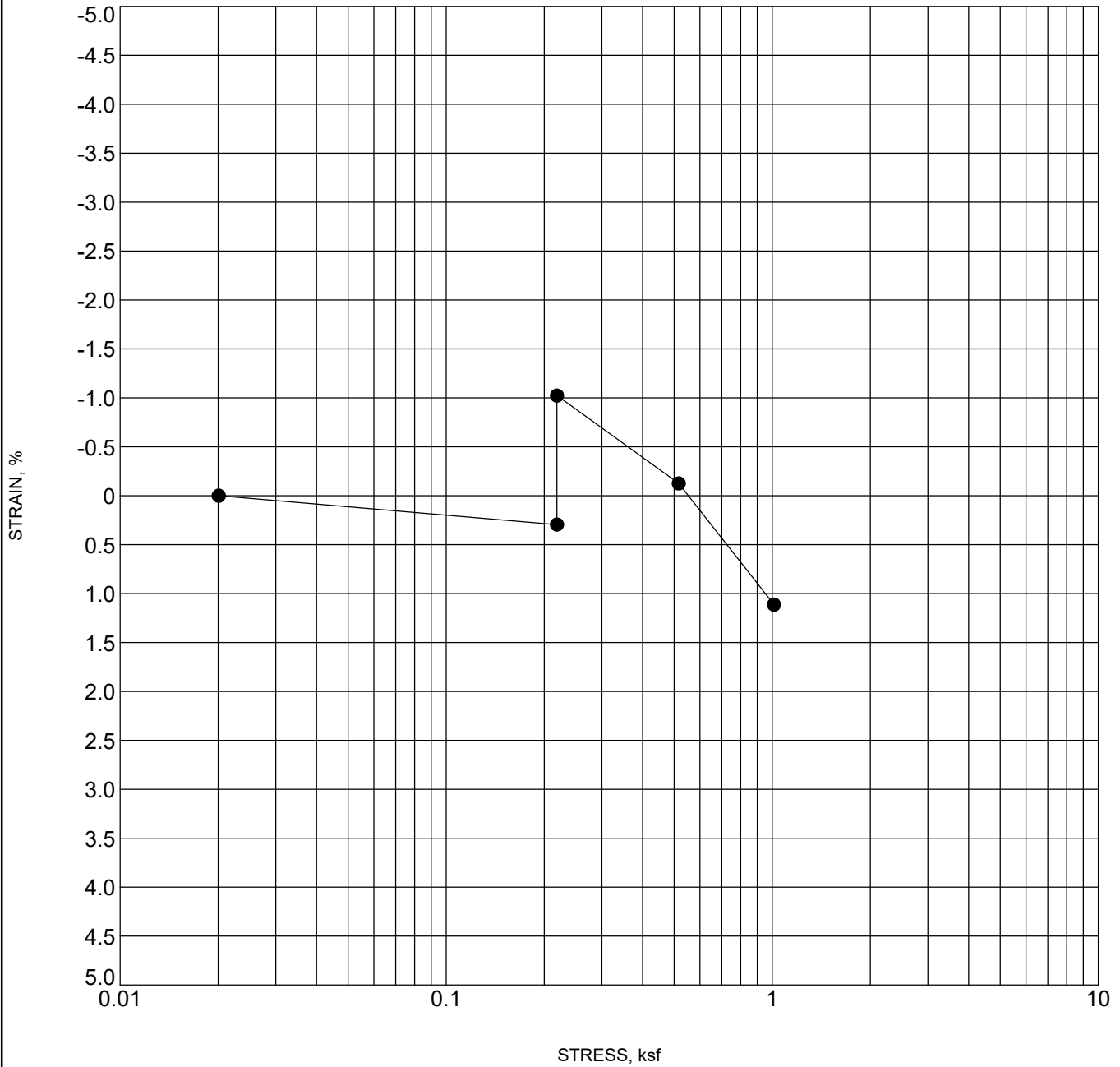

SWELL - CLIENT STANDARD 599.77_EMERSON PARK G.J.GPJ ROCKSOL TEMPLATE.GDT 6/29/23

Specimen Identification	Classification	Swell/Consol. (%)	γ_d (pcf)	MC%
● B-2 4	CLAY	1.3	97.9	25.2

CLIENT City of Grand Junction

PROJECT NAME Emerson Park Geotechnical Investigation

ROCKSOL PROJECT NUMBER 599.77

CLIENT PROJECT NUMBER Grand Junction, Colorado

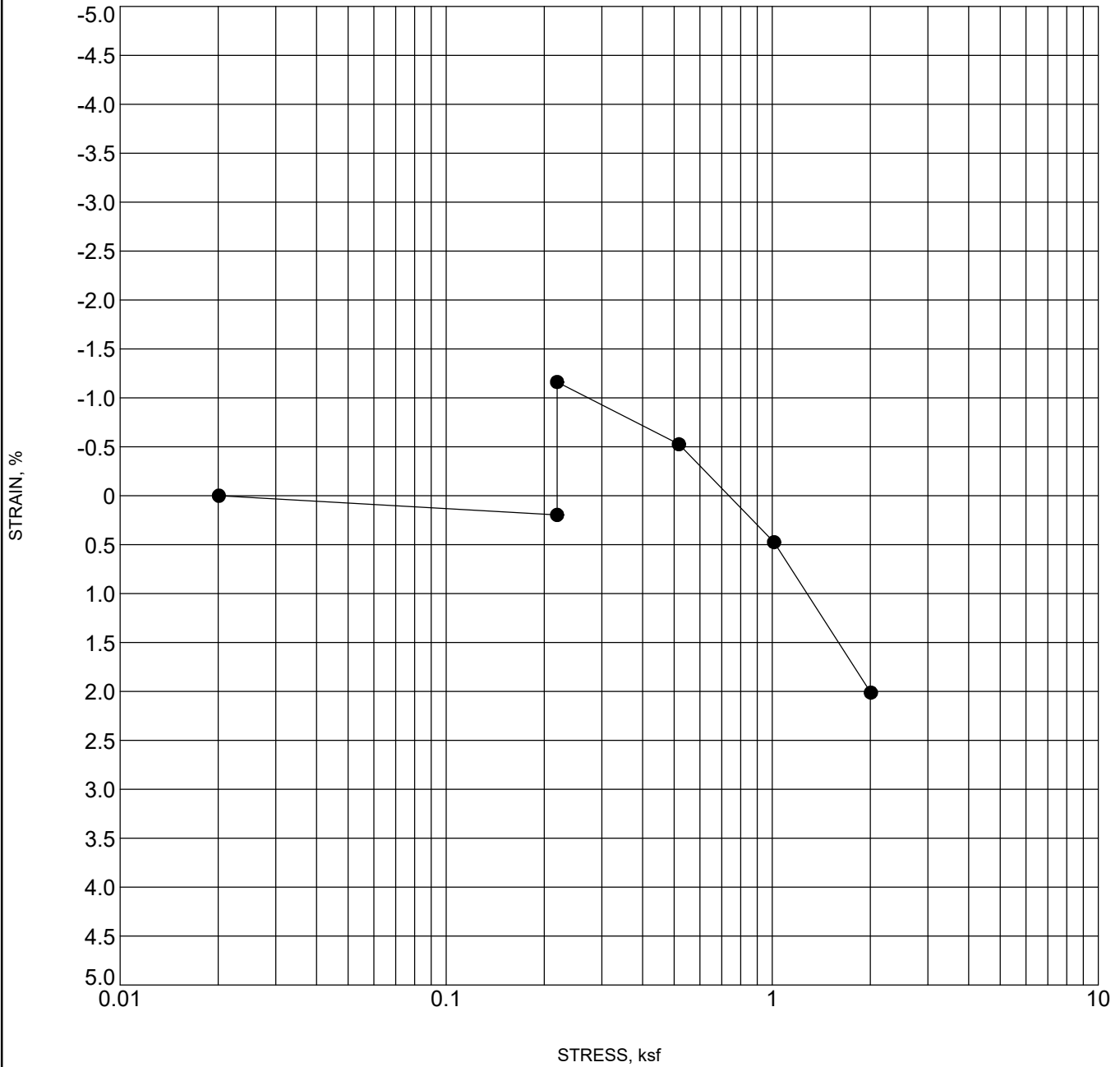

SWELL - CLIENT STANDARD 599.77_EMERSON PARK G.J.GPJ ROCKSOL TEMPLATE.GDT 6/29/23

Specimen Identification	Classification	Swell/Consol. (%)	γ_d (pcf)	MC%
● B-2 9	CLAY	1.4	102.7	22.3

CLIENT City of Grand Junction

PROJECT NAME Emerson Park Geotechnical Investigation

ROCKSOL PROJECT NUMBER 599.77

CLIENT PROJECT NUMBER Grand Junction, Colorado

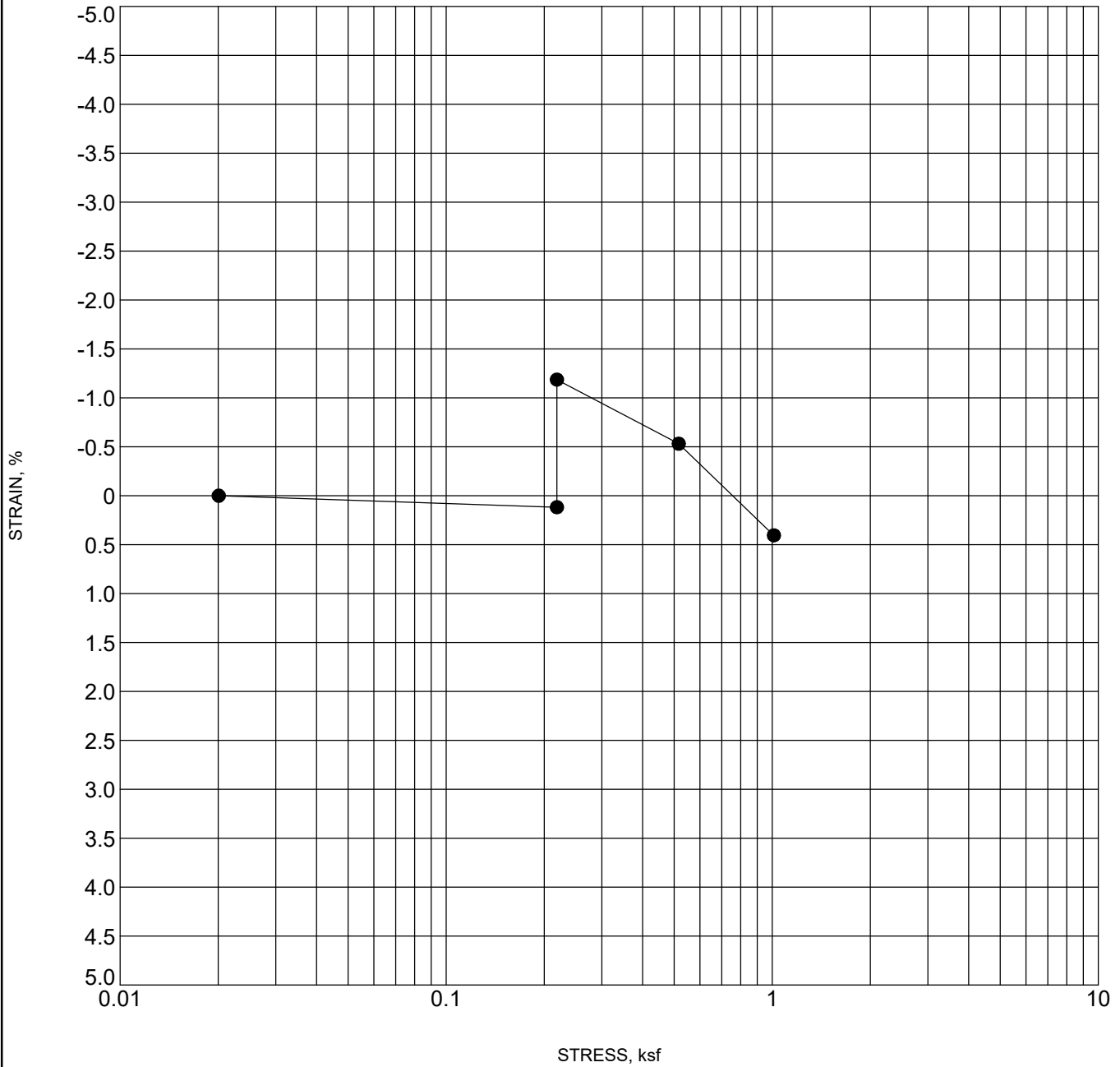

SWELL - CLIENT STANDARD 599.77_EMERSON PARK G.J.GPJ ROCKSOL TEMPLATE.GDT 6/29/23

Specimen Identification	Classification	Swell/Consol. (%)	γ_d (pcf)	MC%
● B-3 2	CLAY	1.3	108.7	18.8

CLIENT City of Grand Junction

PROJECT NAME Emerson Park Geotechnical Investigation

ROCKSOL PROJECT NUMBER 599.77

CLIENT PROJECT NUMBER Grand Junction, Colorado

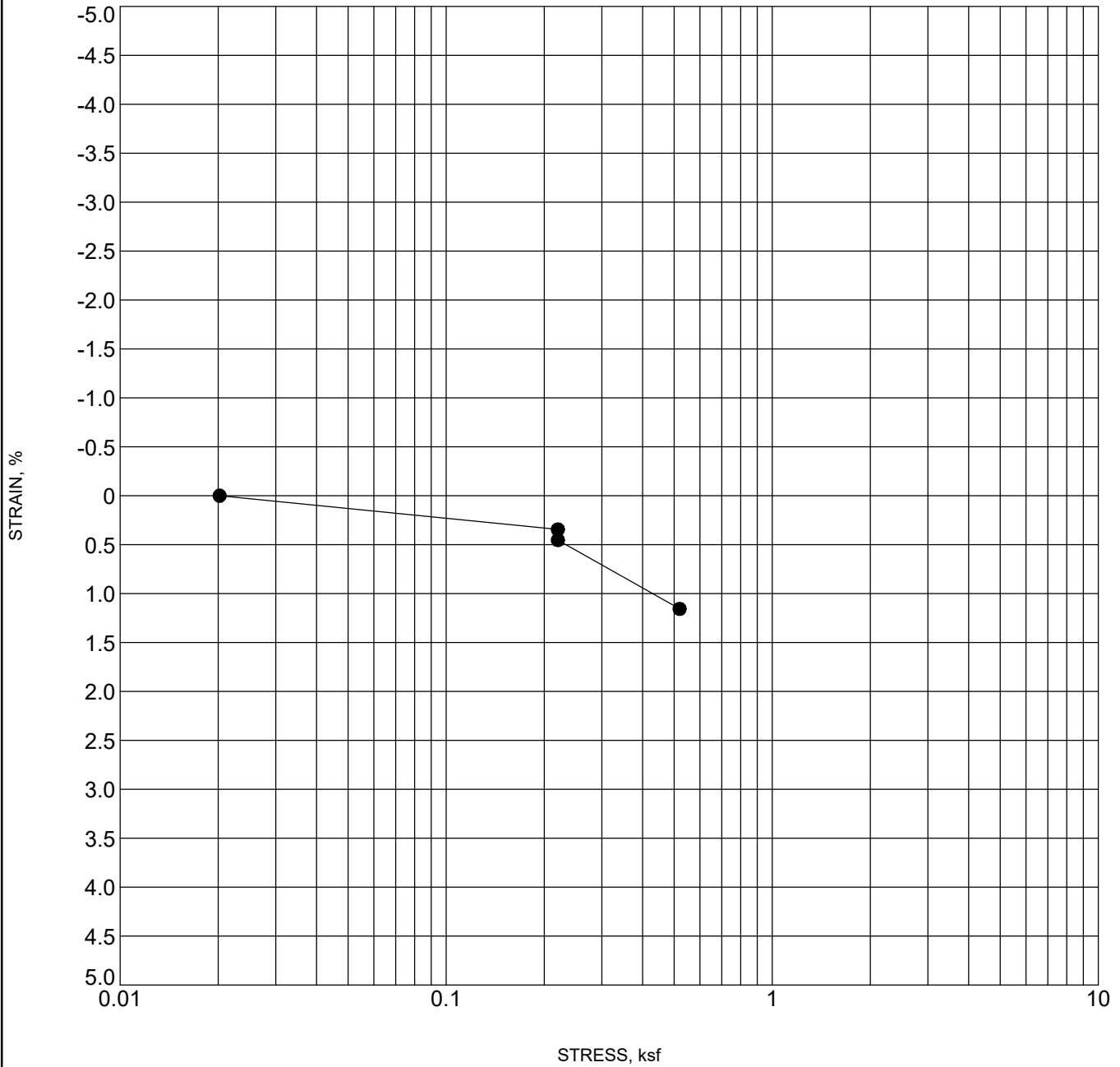

SWELL - CLIENT STANDARD 599.77_EMERSON PARK G.J.GPJ ROCKSOL TEMPLATE.GDT 6/29/23

Specimen Identification	Classification	Swell/Consol. (%)	γ_d (pcf)	MC%
● B-3 4	CLAY	-0.1	102.8	22.0

CLIENT City of Grand Junction

PROJECT NAME Emerson Park Geotechnical Investigation

ROCKSOL PROJECT NUMBER 599.77

CLIENT PROJECT NUMBER Grand Junction, Colorado

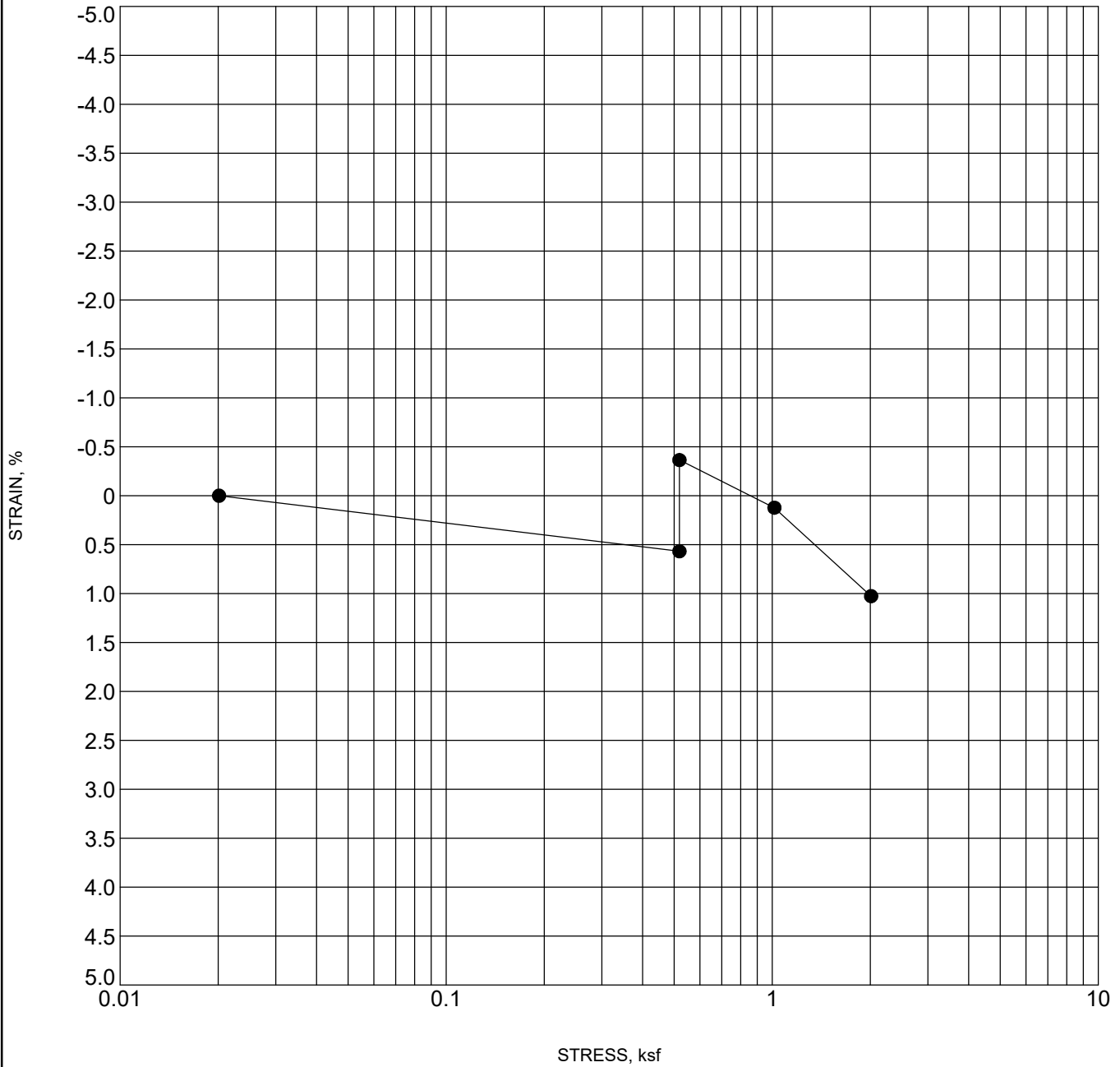

SWELL - CLIENT STANDARD 599.77_EMERSON PARK G.J.GPJ ROCKSOL TEMPLATE.GDT 6/29/23

Specimen Identification	Classification	Swell/Consol. (%)	γ_d (pcf)	MC%
● B-3 9	CLAY	0.9	106.3	20.6

R-VALUE TEST GRAPH (AASHTO T190)

Project Number:	23.022, RockSol Consulting	Date:	06/08/23
Project Name:	City of GJ Emerson Park (RockSol Project No. 599.77)	Technician:	J. De Los Santos
Lab ID Number:	232491	Reviewer:	G. Hoyos
Sample Location:	East Middle Park / Roadway and Parking Area (BH-1 at 3 inches to 4 feet)		
Visual Description:	CLAY, sandy, brown		

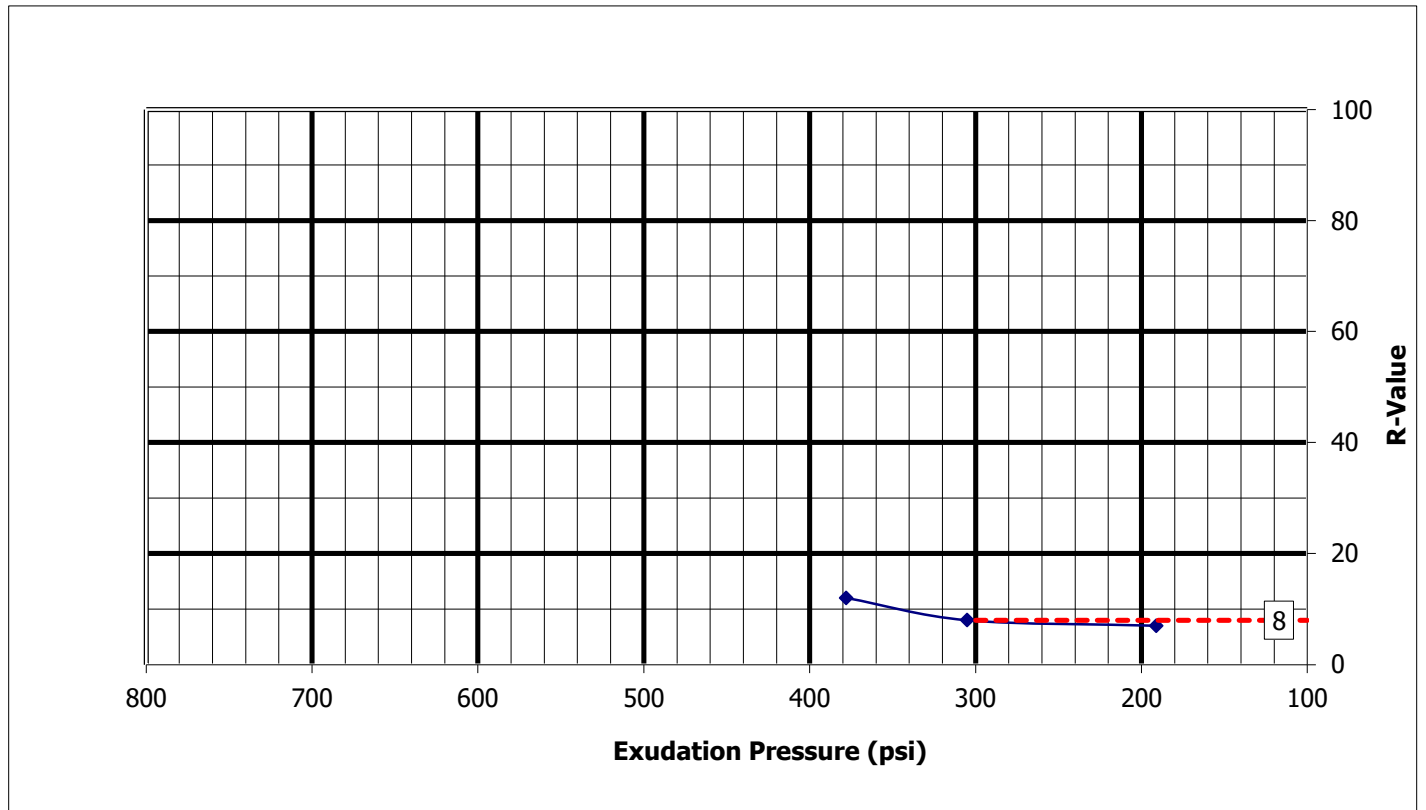

R-Value @ Exudation Pressure 300 psi: 8
Specification:

CDOT Pavement Design Manual, 2011.
 Eq. 2.1 & 2.2, page 2-3.

$S_1 = [(R-5)/11.29]+3$ **$S_1 = 3.27$**
 $M_R = 10^{[(S_1 + 18.72)/6.24]}$ **$M_R = 3,337$**

M_R = Resilient Modulus, psi
 S_1 = the Soil Support Value
 R = the R-Value obtained

Test Specimen:	1	2	3
Moisture Content, %:	17.0	19.6	21.4
Expansion Pressure, psi:	0.85	0.49	0.12
Dry Density, pcf:	114.5	108.1	104.7
R-Value:	12	8	7
Exudation Pressure, psi:	378	305	191

Note: The R-Value is measured; the M_R is an approximation from correlation formulas.

APPENDIX C

PAVEXPRESS PAVEMENT DESIGN OUTPUT SHEET

Project: Emerson Park



New Asphalt Pavement Design

AASHTO '93/'98: Flexible Pavement Design

Pavement Diagram

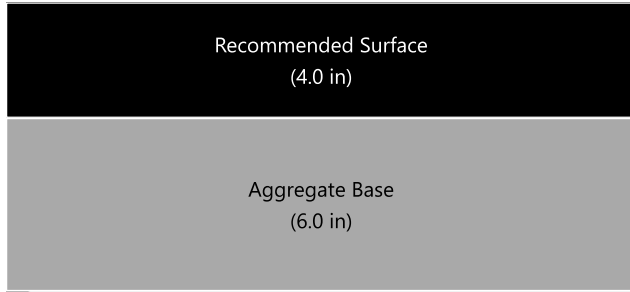

Details

Scenario: New Asphalt Pavement Design

Created By: Jay Goldbaum, Goldbaum@RockSol.com

Last Modified: June 28, 2023 5:57:19 pm

Design Parameters

Design Period: 30 years

Reliability Level (R): 80%

Combined Standard Error (S_0): 0.44

Initial Servicability Index (p_i): 4.5

Terminal Servicability Index (p_t): 2

Delta Servicability Index (ΔPSI): 2.5

Total Design ESALs (W_{18}): 20000

Required minimum design SN: 2.40

Layer Thicknesses (in)

Recommended Surface: 4.0 in

Aggregate Base: 6.0 in

Total SN: 2.41

Print

Layers

Recommended Surface - Asphalt

Thickness: 4 in

Aggregate Base - Base

Thickness: 6 in

Structural Coefficient: 0.12

Drainage Coefficient: 0.9

Thanks for the brief call this morning and for sending me your Conceptual Layouts for the Emerson Skate Park.

Specifically to your question “does the subgrade all under the site concrete and skate bowls all follow the same recommendation of Section 9.2 for recompacting of the top 6” of Subgrade and 95% Compaction of T99 Proctor”.

- I confirmed with our Geotechnical Engineer Don Hunt, and **yes** our intent is that all disturbed subgrade will require recompacting of the top 6” to 95% of T99.
- Note we did identify in the report that for existing “undisturbed” soils at this location they actually do show relatively good densification. However, we assume as a contractor excavates this area they will disturb the soils and thus the need for reconditioning and compaction.

Don and I did discuss a couple of other related issues.

- We also note that these subgrade materials are at 90%-98% Saturated in their existing state. For this reason, a contractor that excavates this area will need to do so with relatively light weight equipment. If a contractor comes in with large heavy equipment there will likely be pumping and instability with the subgrade.
- So this really becomes a question **of constructability**. I could see a situation that the contractor excavates then tries to recompact, and they say “this material is unstable and needs over-excavation and backfill with a select material”.
- For your design of reinforced concrete, we expect that once the concrete is in place it will support all of the loadings that you have calculated, but the challenge may be getting the concrete in place.

For the above stated reasons it may be something you want to consider addressing in your plans. As example you may want to include some sort of language such as “the contractor must take account for excavation and compaction with lightweight equipment, or they will need to allow the material to properly dry prior to compaction” – as example.

We did not provide recommendations for over-excavation and select fill for soft spots, but we can include that if you all feel warranted. Typically our recommendation for that type of situation would be a Hi Tensile Separator fabric on the subgrade, and select material such as 12” of ABC Class 3 to provide that working platform. Again, I want to clarify this would be more of a recommendation to assist with construction vs. the actual need for structural support. However, this might be something the City of GJ would like to see to avoid conflicts with the contractor during construction. Our position is that we feel it can be constructed without this, but from our experience there is risk a contractor will feel differently.

Lastly Don and I did again discuss drainage. I’m not sure how these bowls actually drain when they get surface water, but with these A6 Soils, and relatively shallow ground water please recognize the permeability is very low. So if these bowls just rely on natural drainage into the ground, this particular location will likely not drain well. Maybe it is already part of your design consideration, but there likely needs to be some sort of drainage system that takes this water away from the bottom of the hole.

Don and I would be glad to set up a conference call if you would like to discuss any of these items further.

Thanks again for reaching out and we look forward to assisting you with any other questions or recommendations.

Dave

David A. Eller, P.E.

Senior Transportation Manager

RockSol Consulting Group, Inc.

566 West Crete Circle, Suite 2, Grand Junction, CO 81505

Direct Line 970.822.4350 Cell 970.210.8098

Main Office 303.962.9300 Fax 303.962.9350

Web www.rocksol.com Email eller@rocksol.com



TREE LEGEND

●	UNHEALTHY TREES
●	HEALTHY TREES
●	TREES THAT CAN BE RELOCATED

TRAFFIC ACCIDENT ZONE
 EXISTING RESTROOM STRUCTURE
 EXISTING SIDEWALKS
 EXISTING PLAYGROUND
 TRAFFIC ACCIDENT ZONE

NOTE:

1. ALL TREE LOCATIONS AND PROPERTY LINE ARE APPROXIMATE BASED OFF OF PDF INFORMATION PROVIDED BY THE CITY OF GRAND JUNCTION

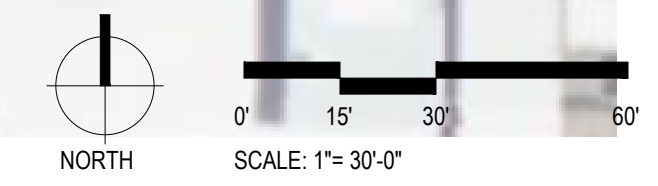

©CLAUSON RAWLEY ASSOCIATES, INC 2023

CLAUSON RAWLEY ASSOCIATES INC
 landscape architecture · planning · resort design

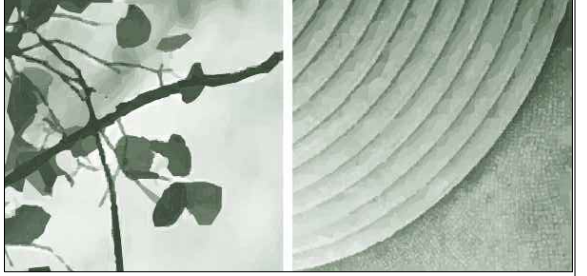

EMERSON PARK

ADDRESS:
 GRAND JUNCTION, CO
 PARCEL #

DATE:
 05.09.2023

ISSUE:
 FOR PLANNING PURPOSES ONLY
 NOT FOR CONSTRUCTION

DRAWN BY: BAJ CHECKED BY: PSR

HISTORY:

DATE	ISSUE
00.00.2022	

DRAFT

SHEET TITLE:

EXISTING CONDITIONS

L1.00

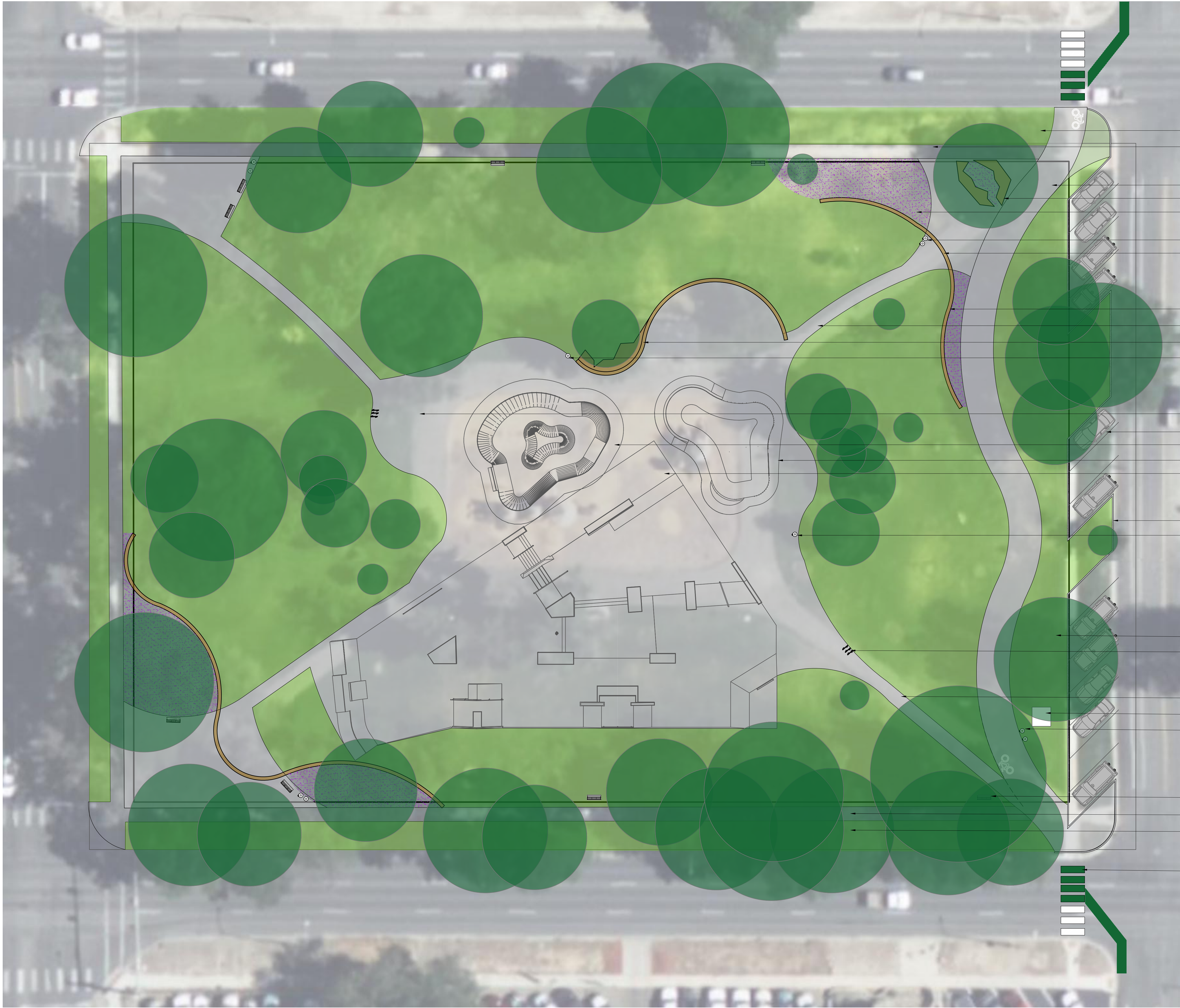

- EXISTING TREE LAWNS TO REMAIN
- EXISTING SIDEWALKS TO REMAIN
- 14' RELOCATED BIKE PATH
- 20' PLANTER SEATWALL
- PERENNIAL PLANTER BEDS, TYP.
- TRASH AND RECYCLE RECEPTACLES
- PAVER PATTERN BETWEEN LANDSCAPE WALLS
- 32" SERPENTINE LANDSCAPE WALL
- 6' CONCRETE SIDEWALKS
- 20' SERPENTINE SEATWALL
- TRASH RECEPTACLE, TYP.
- EVENT PLAZA SPACE
- (14) PROPOSED ANGLED PARKING STALLS
- SKATE BOWL
- SKATE BOWL
- STREET COURSE
- 6" CONCRETE CURB
- TRASH RECEPTACLE
- EXISTING TREES TO REMAIN, TYP.
- (3) LOOP BIKE RACKS
- 6' SIDEWALK
- PORTO STRUCTURE
- TRASH AND RECYCLE RECEPTACLES
- PARK BENCH, TYP.
- EXISTING SIDEWALK TO REMAIN
- EXISTING TREE LAWN TO REMAIN
- PROPOSED SHARED BIKE/PED CROSSING

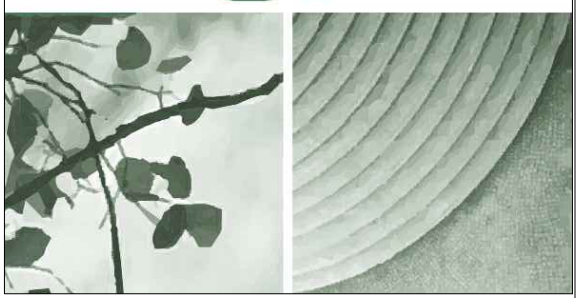

EMERSON PARK

ADDRESS:
GRAND JUNCTION, CO
PARCEL #

DATE:
05.09.2023

ISSUE:
FOR PLANNING
PURPOSES ONLY
NOT FOR CONSTRUCTION

DRAWN BY: BAJ CHECKED BY: PSR

HISTORY:

DATE	ISSUE
00.00.2022	

DRAFT

SHEET TITLE:

SCHEMATIC
LANDSCAPE

LX.XX

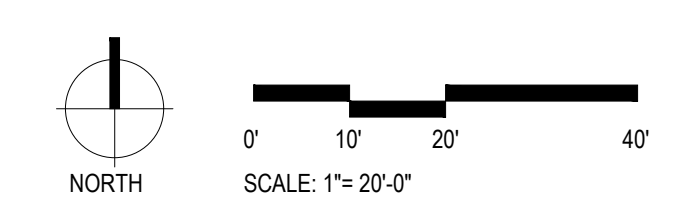

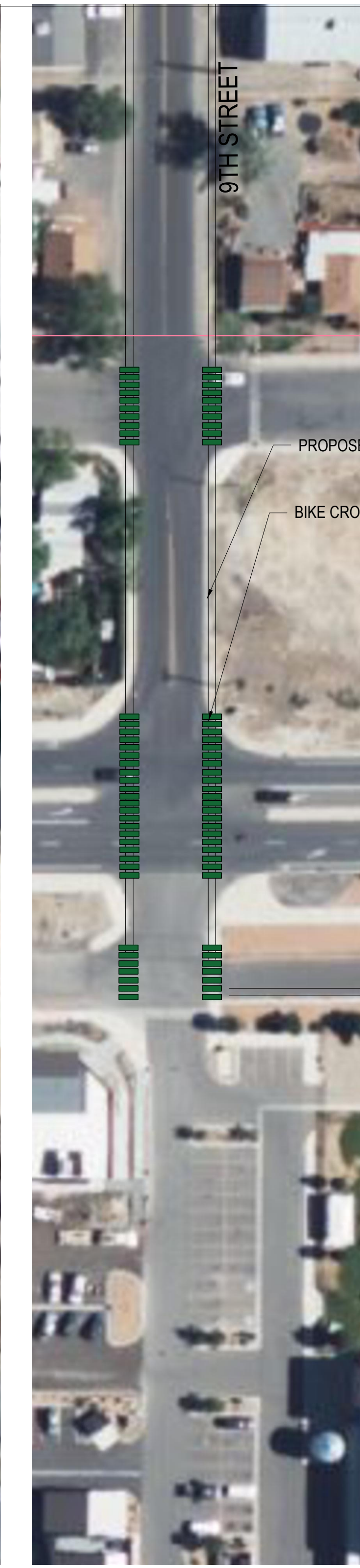
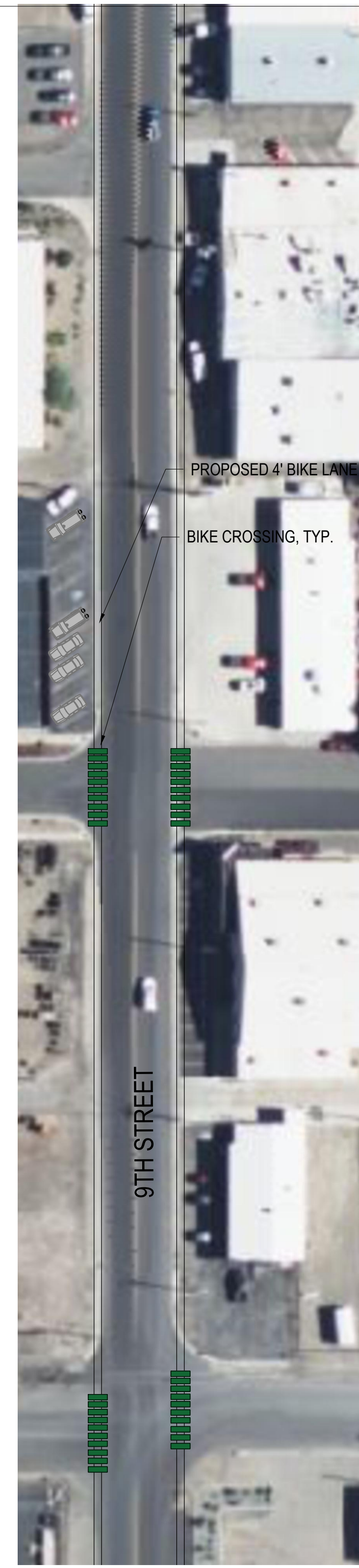

EMERSON PARK

ADDRESS:
GRAND JUNCTION, CO
PARCEL #

DATE:
05.09.2023

ISSUE:
FOR PLANNING
PURPOSES ONLY
NOT FOR CONSTRUCTION

DRAWN BY: BAJ CHECKED BY: PSR

HISTORY:

DATE	ISSUE
00.00.2022	

DRAFT

STAMP PER DISCIPLINE

PROFESSIONAL STAMPS

SHEET TITLE:

XXXX

LX.XX

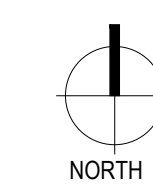

EMERSON PARK- GRAND JUNCTION, CO

SITE ANALYSIS

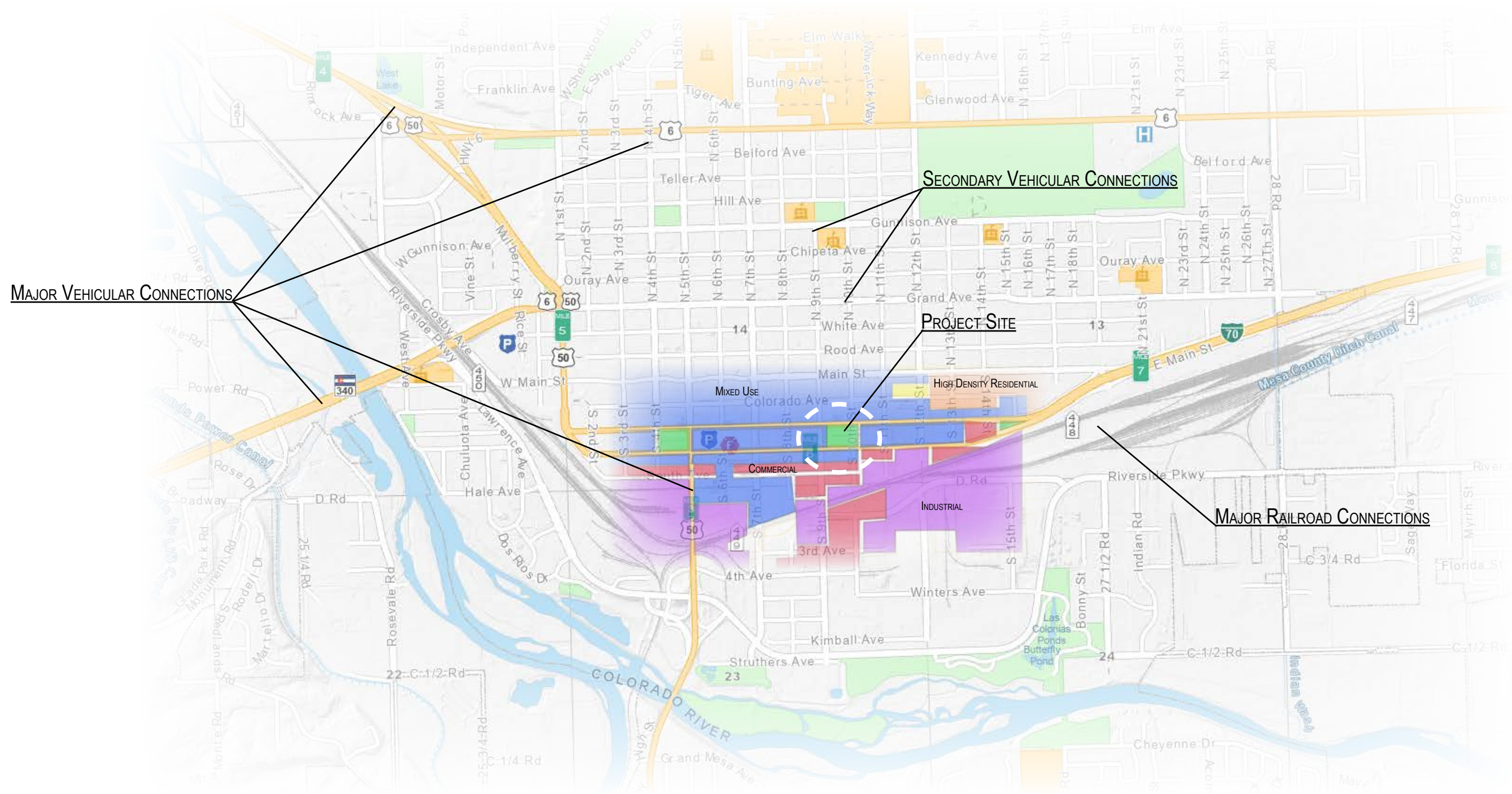

EMERSON PARK- GRAND JUNCTION, CO
SITE ANALYSIS

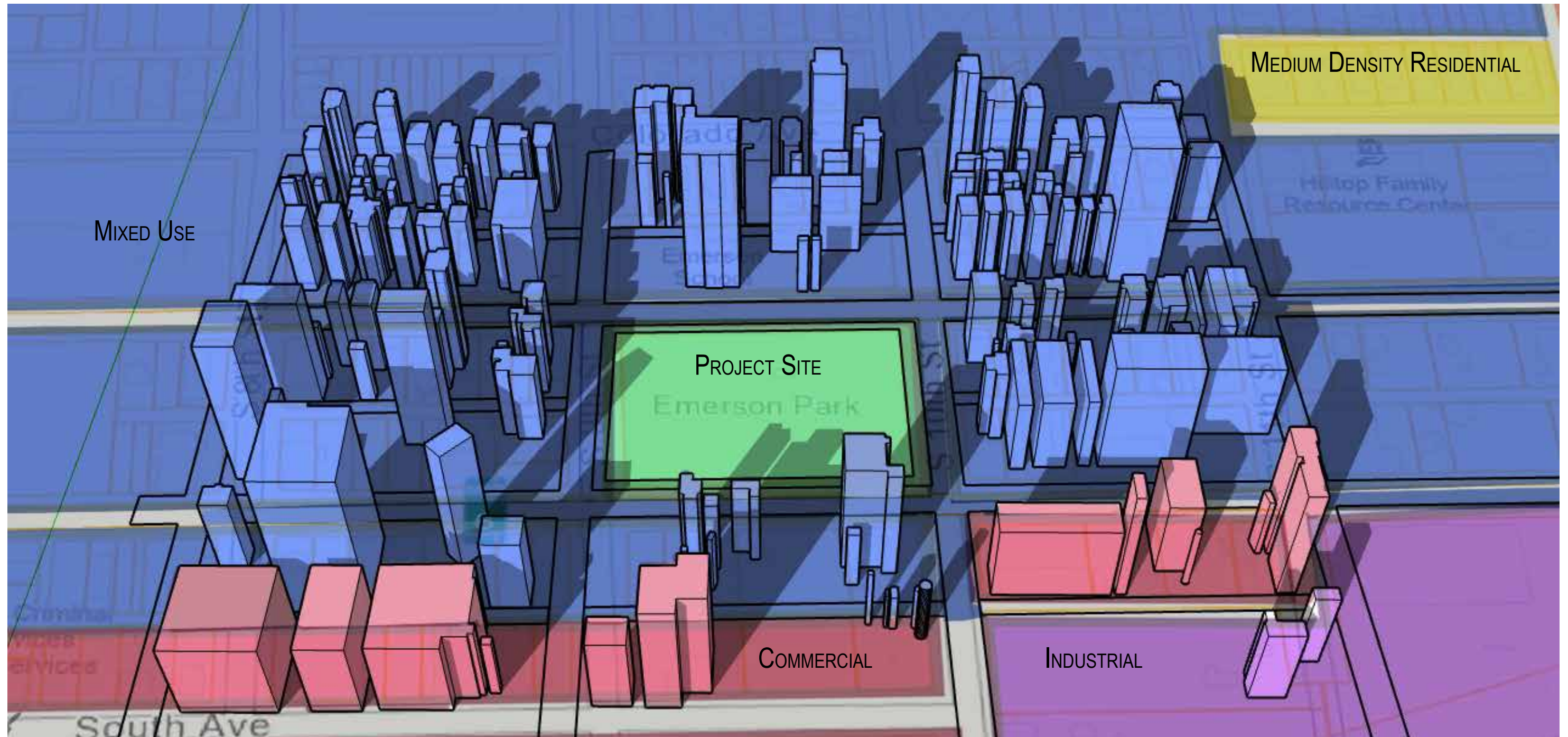

EMERSON PARK- GRAND JUNCTION, CO

SITE ANALYSIS

PEDESTRIAN CROSSING IMPROVEMENTS BY OTHERS



POSSIBLE OVERFLOW PARKING



PROPOSED PARKING ENTRANCE SIDE OF THE PARK

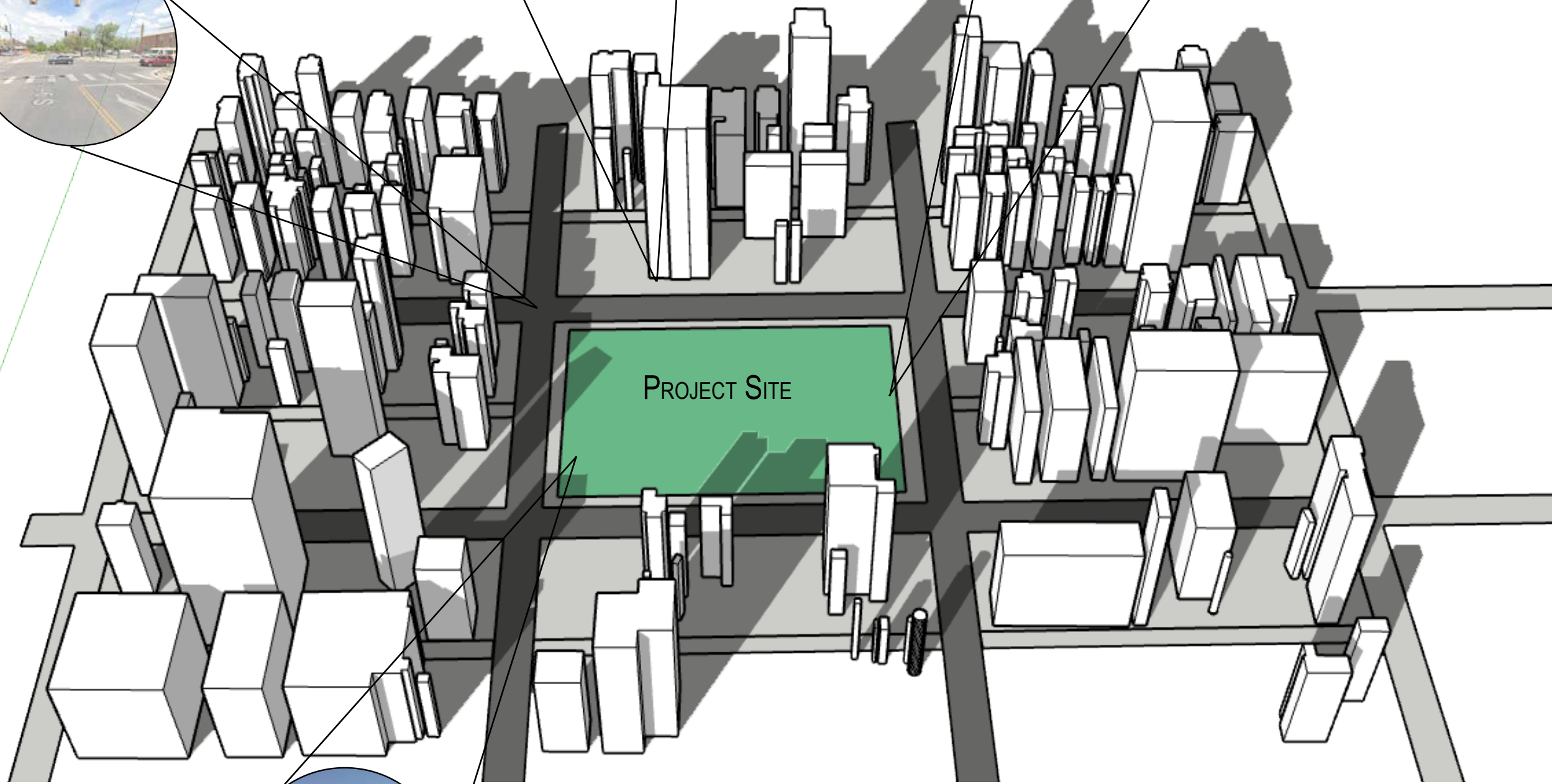

VIEWS TO THE RIDGE LINE OF COLORADO NATIONAL MONUMENT



EMERSON PARK- GRAND JUNCTION, CO

SITE ANALYSIS

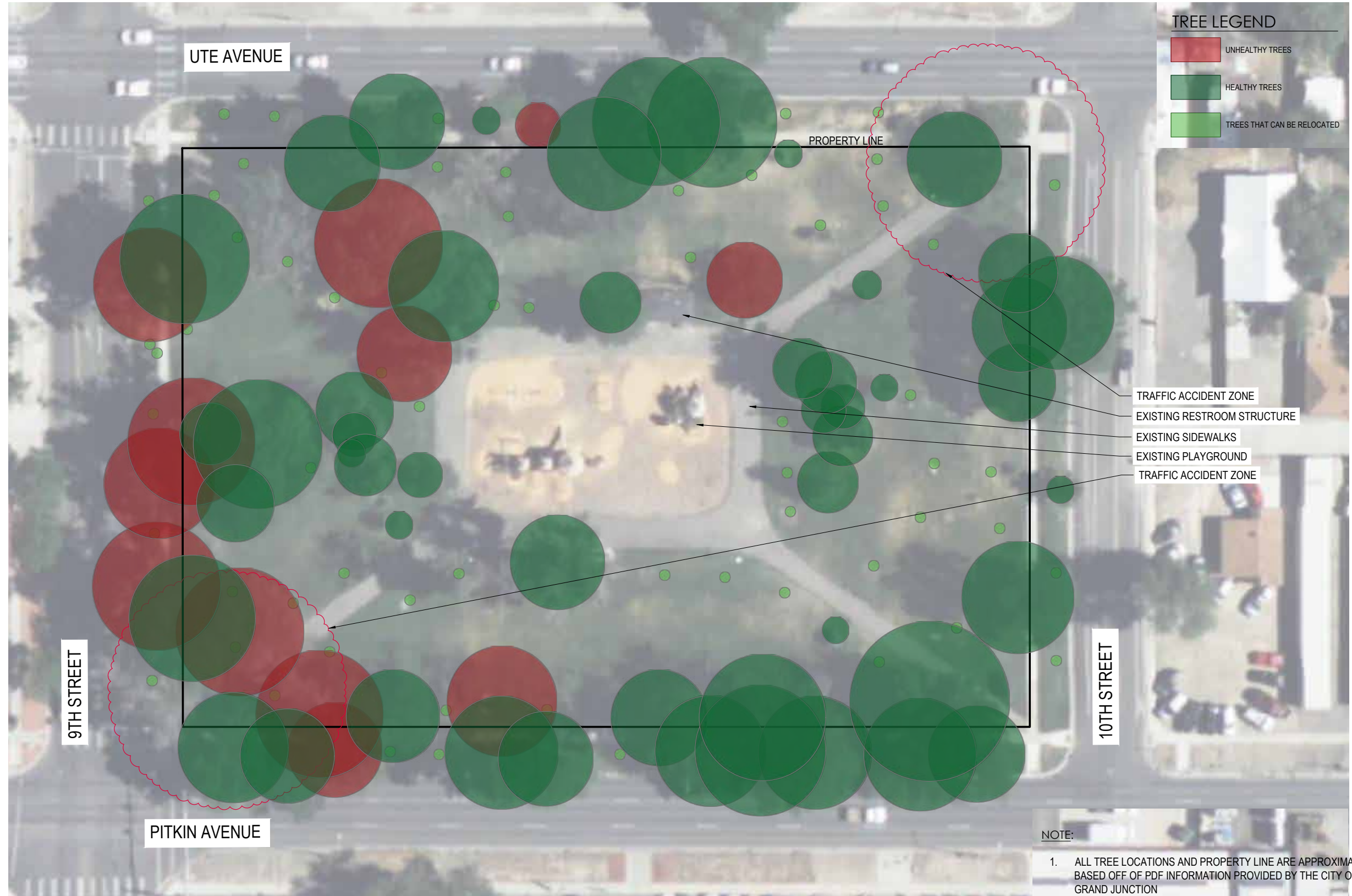

EMERSON PARK- GRAND JUNCTION, CO
CONCEPTUAL LANDSCAPE PLAN

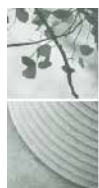
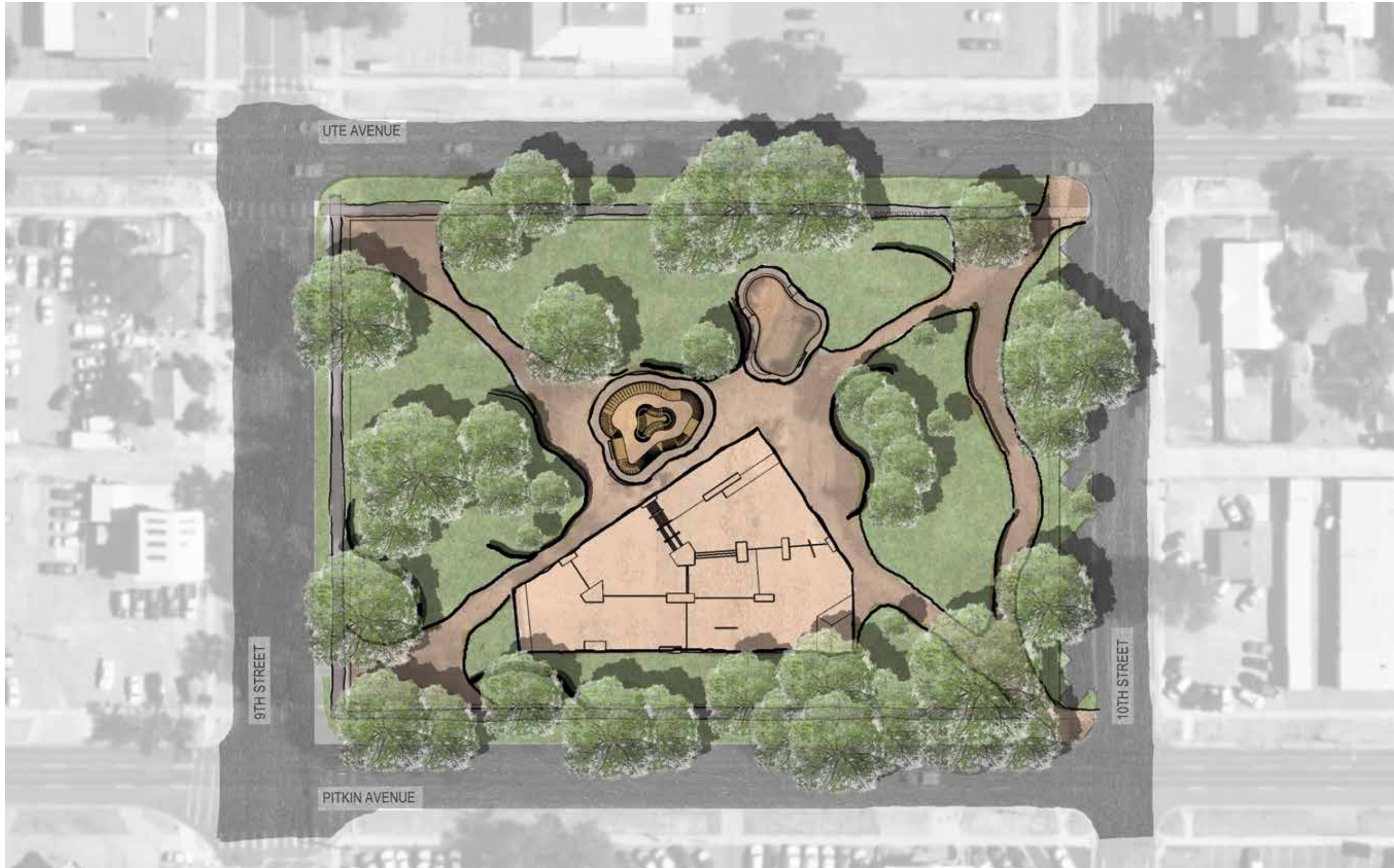

EMERSON PARK- GRAND JUNCTION, CO
CONCEPTUAL INSPIRATION IMAGERY

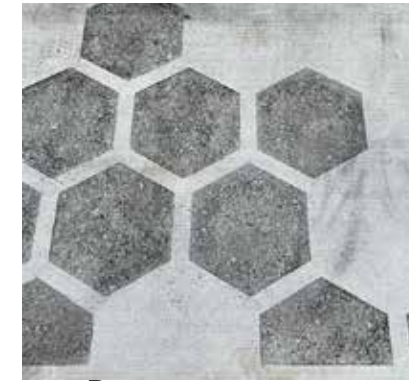

DECORATIVE CONCRETE



LASER CUT CORTEN



SKATE-ABLE PLANTERS



GRADE CHANGING
 SKATE-ABLE SEATWALLS



SERPENTINE SEATWALLS



PERENNIAL GRASSES



POCKET PLANTER AREAS



PERENNIAL FLOWER POPS

EMERSON PARK- GRAND JUNCTION, CO

SCHEMATIC LANDSCAPE PLAN

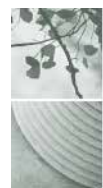

EMERSON PARK- GRAND JUNCTION, CO
SCHEMATIC LANDSCAPE IMAGERY

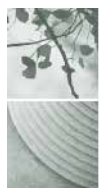

EMERSON PARK- GRAND JUNCTION, CO

SCHEMATIC LANDSCAPE IMAGERY



EMERSON PARK- GRAND JUNCTION, CO
SCHEMATIC SITE FEATURES/MATERIALS



LOOP BIKE RACK
LANDSCAPE FORMS



6' TEAK SILHOUETTE BENCH
BARCO PRODUCTS



DOG WASTE STATION
DOG WASTE DEPOT



CASSIDY 45 GALLON TRASH & RECYCLE
BARCO PRODUCTS

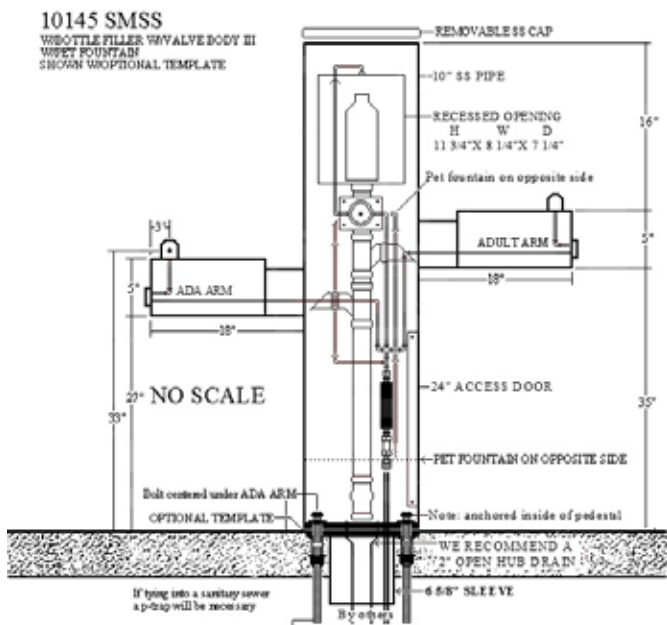

10145 SMSS ADA WATER FOUNTAIN
MOST DEPENDABLE FOUNTAINS



SEATWALLS & SITEWALLS
DELTA BRICK COMPANY



COLORLED CONCRETE SEATWALLS
DAVIS MIAMI BUFF



PORTO SCREEN STRUCTURE
CITY OF GRAND JUNCTION

EMERSON PARK- GRAND JUNCTION, CO
SCHEMATIC PLANT MATERIALS



MEXICAN FEATHERGRASS
NASSELLA TENUISSIMA
PERENNIAL BEDS



MAY NIGHT SALVIA
SALVIA X SYLVESTRIS 'MAY NIGHT'
PERENNIAL BEDS



EXISTING TREES AND LAWN TO REMAIN
TREE PROTECTION FENCING AND
RESEED DISTURBED AREAS WITH LAWN



CONCEPTUAL DESIGN
INPUT MEETING
FOR
EMERSON PARK
SKATEPARK

MAY 9TH, 2023
6 PM Mountain Time

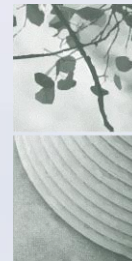

CLAUSON RAWLEY ASSOCIATES INC
landscape architecture. planning. resort design

TEAM PAIN

SKATE PARKS

RECORDING

IN SESSION

THIS MEETING IS BEING RECORDED. WE WILL HAVE THE MEETING AVAILABLE ON YOUTUBE STARTING TOMORROW FOR ONE WEEK FOR ANYONE THAT WAS UNABLE TO ATTEND. THIS RECORDING MAY HELP YOU WITH FILLING OUT THE QUESTIONNAIRE.

IF YOU HAVE QUESTIONS DURING THE PRESENTATION, PLEASE TYPE THEM INTO THE CHAT BAR ON THE RIGHT SIDE OF YOUR SCREEN. TEAM PAIN WILL BE ADDRESSING QUESTIONS, IN ORDER, AFTER THE PRESENTATION IS COMPLETED.

ONCE WE GET TO THE Q&A SECTION, WE WILL PROVIDE EVERYONE WITH A URL THAT WILL CONNECT YOU TO A QUESTIONNAIRE. WE WANT YOUR FEEDBACK, SO PLEASE FILL THIS OUT.



Grand Junction Skate Park Virtual Public Input Meeting



Come give your input on the conceptual design for the Emerson Park Skate Park!

May 9, 2023
6 PM Mountain time

Please join the meeting from your computer, tablet or smartphone.
<https://meet.goto.com/TeamPain/grandjunctionskateparkpublicinputmeeting>

You can also dial in using your phone. Access Code:
796-567-965
United States:
+1 (571) 317-3122

Get the app now and be ready when the first meeting starts:
<https://meet.goto.com/install>

CITY OF
Grand Junction
COLORADO
PARKS & RECREATION

TEAM PAIN
SKATE PARKS



CITY OF
Grand Junction
COLORADO
PARKS & RECREATION

CONCEPTUAL DESIGN INPUT MEETING FOR EMERSON PARK SKATEPARK

MAY 9TH, 2023
6 PM Mountain Time



TEAM PAJN
SKATE PARKS



30+ YEARS SKATE PARK EXPERIENCE



- CONTINUOUS CUSTOM POURED IN PLACE CONCRETE SKATE PARKS SINCE 1997
- RECOGNIZED FOR FIRST EVER STRUCTURES
- PROJECTS WORLD-WIDE
- EXTENSIVE GOVERNMENT EXPERIENCE
- EXTENSIVE INDUSTRY EXPERIENCE
- PRESTIGIOUS PUBLICATIONS & AWARDS





LANDSCAPE ARCHITECT
MARCH 2019

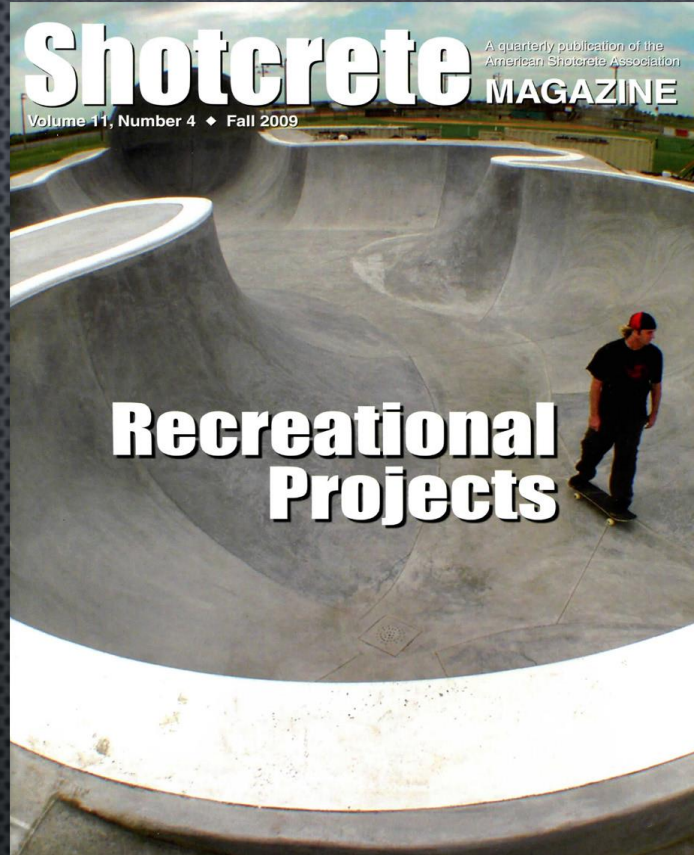

COVER: SHOTCRETE MAGAZINE
FALL 2009
RECREATIONAL PROJECTS



TIME MAGAZINE
AUGUST 7, 2006
"IT'S ALL IN THE SWOOP"



The Architect Of Awesome Ripping

TIM PAYNE at one of his newest projects, the not-yet-opened Apollo Beach Park, Apollo, Fla. "You can't get the guys to stop skating," he said. "That's when you know you've done a good job."

CREATING: TIM PAYNE, SKATE-PARK DESIGNER

BY STEVE KNOPPER

ONE DAY IN 1972, a friend from the beach rolled up to 12-year-old Tim Payne's house in Orlando on a wooden water ski he'd converted into a skateboard. "He made it sound fun," Mr. Payne recalled, "and the next day I was building one of my own."

Unfortunately, Florida is flat. So they had to improvise, scavenging construction sites for materials, screwing plywood into the sides of

RAMPING IT UP

BE PATIENT
A barber at the new Arvada Skate Park pulls off a hurricane grind on "The Downway." It's an oblique feature that Team Pain has been trying to install in its parks for years. "Finally, Arvada had enough space," said Tim Payne.



START SMALL
Before designing the Arvada park, left, Team Pain contracted with the Denver suburb to design a "skate spot" in a much smaller nearby area. The team's willingness to focus on a tiny project impressed parks official Mike Lee.

stores at the shopping center and riding up and down the walls. They found ideas in skater magazines. As skateboarding grew from suburban pockets of punk-rock kids scraping up empty pools and parking lots to a multimillion-dollar industry, Mr. Payne evolved into a world-class ramp builder. He saw things nobody else could. In 1987, for a video called "The Search for Animal Chin," Mr. Payne built a spine ramp, which stretched together two wide "pools" into a curvy "W" shape, with a platform in the middle. The video became a cult film, and every skateboarder immediately wanted to ride his ramp. Today, his 15-year-old Team Pain, based in an office park in Winter Springs, Fla., is the go-to company for cities that crave skate parks built by actual skaters. Mr. Payne, 52, has overseen 250 of them. Mr. Payne works 8 a.m. to 6 p.m. at his office park, where 30 or so employees hunch over their computers and drawings when they're not in the

field. The first step is getting the site map from the city—this becomes the canvas. Any shape will do, although Mr. Payne hates squares, which he associates with boring tennis courts. Every Team Pain employee is a skateboarder, so they look at the world in a unique way. Asked for specific structures that have inspired him, Mr. Payne e-mails 13 photos of old parks, giant industrial pipes, public benches and the whimsically shaped "Seuss Landing" area within Universal's Islands of Adventure theme park.

"Just growing up as a skateboarder, you're looking for spots to skate," he said. Mr. Payne still cuts photos out of magazines, as he did when he was young, and the pictures hang all over the Team Pain offices. Team Pain designed the \$2.1 million skate park for the city of Arvada, near Denver. With the city's map of the park in hand—10,000 square feet, in a sort of trapezoid—Mr. Payne's employ-

ees began sketching out ideas with three-dimensional software. Soon they were texting images to each other and exchanging comments.

Mr. Payne contributed the first feature: a snake run, or bumpy concrete rut that starts shallow and opens into a deep bowl. On a recent spring evening, skaters plunged into the wide bowl of Mr. Payne's snake run. Their momentum took them to the curved bottom, then back up along the smooth walls, allowing them to spring up, two feet in the air. The best riders grabbed their boards, fastened them to their feet, briefly defying gravity.

For all the computer rendering they do, their most important tools are the boards themselves.

Every member of a given Team Pain crew gets to brainstorm tricks and features. After that, it's often lead designer Tito Pizarra who assembles them into a space. "It's almost like coming up with that cool Lego piece, but someone has to put that Lego set together," he said. "That's what I do."

Mr. Payne has the final word on any park design, but he's gentle when overruling his team. "I try and keep it light so I don't strangle their creativity," he said. "I might edit it in secret and show up the next day with something different instead of just squashing them."

For all the computer rendering they do, Team Pain employees' most important tools are the boards themselves. Mr. Payne keeps 50 collectible boards in the closet of his Winter Springs home, where he and his 16-year-old son, Riley, skate on a giant ramp just back. Mr. Payne skates once or twice a week, and his board of choice is an 8½-inch-wide Element, with a 15-inch wheel base and alloy trucks.

Mr. Payne always knows when his work is complete. As his crew puts the finishing touches on a park, he watches them try it out. "You can't get the guys to stop skating," he said. "You're sitting in the car—let's go!"—and they're still riding. That's when you know you've done a good job.

WATCH A VIDEO ON YOUR PHONE

Scan this image with a smart-phone QR reader app to see a video with Tim Payne, or visit WSJ.com/Review.

HELL OF A PARADISE
THRASHER

INTERVIEWS
JON DICKSON
ERICK WINKOWSKI
ZION WRIGHT
MOTHER KNOWS BEST
RIZZO, WILSON,
CROCKETT
AND MORE
TERMINAL TOURISTS
GRANT, COLLIN
& MILTON
SMASH SOUTH AMERICA

JULY 2012 ThrasherMagazine.com
\$4.99 US & CANADA
7 1658 03029 0

CHARITABLE ORGANIZATIONS

GRIND FOR LIFE

MIKE ROGERS -
HELPING PEOPLE
WITH CANCER

BROADS FOR BROS

National
ORGANIZATION GIVING
BOARDS AWAY TO
UNDER PRIVILEGED
YOUTH

TEAM PAIN
SKATE PARKS



CONTEST SERIES

ASF

ADAPTIVE SPORTS
FOUNDATION

TEAM PAIN
SKATE PARKS



SPECIAL RECOGNITION

HANDYCAP
FRIENDLY
SKATEPARK

TEAM PAIN
SKATE PARKS



IDENTITY

- SKATEABLE ART
- UNIQUE FEATURES





ART





**BRICK
STAMPING**



COLORED
CONCRETE







ACID
STAIN



GRANITE/
MARBLE





Acid stain

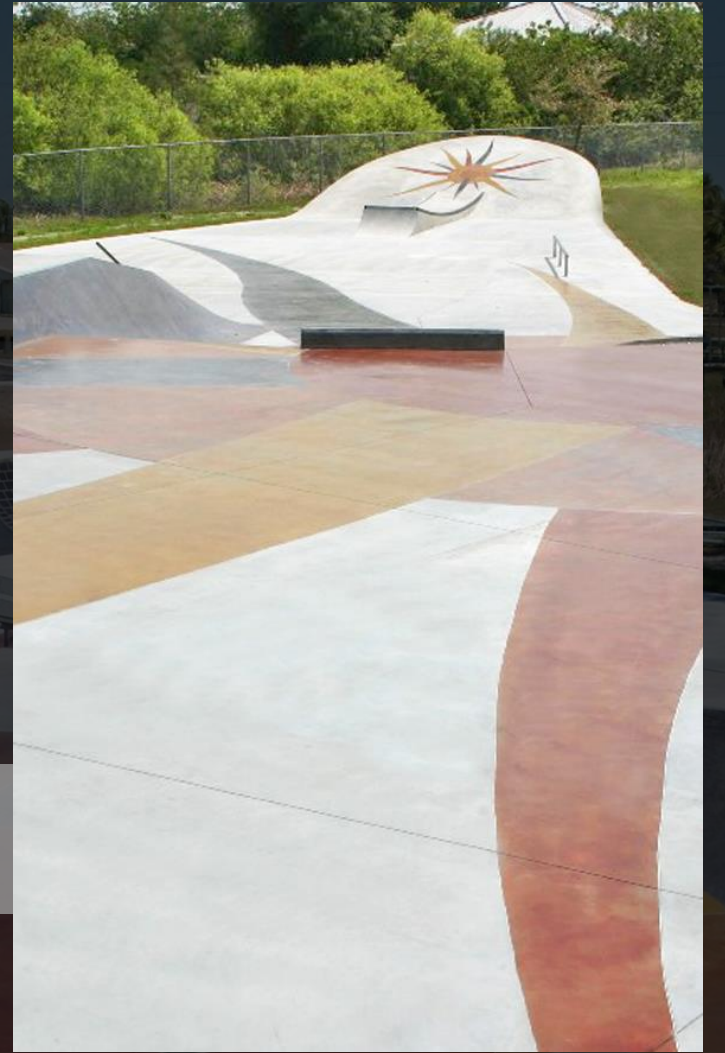
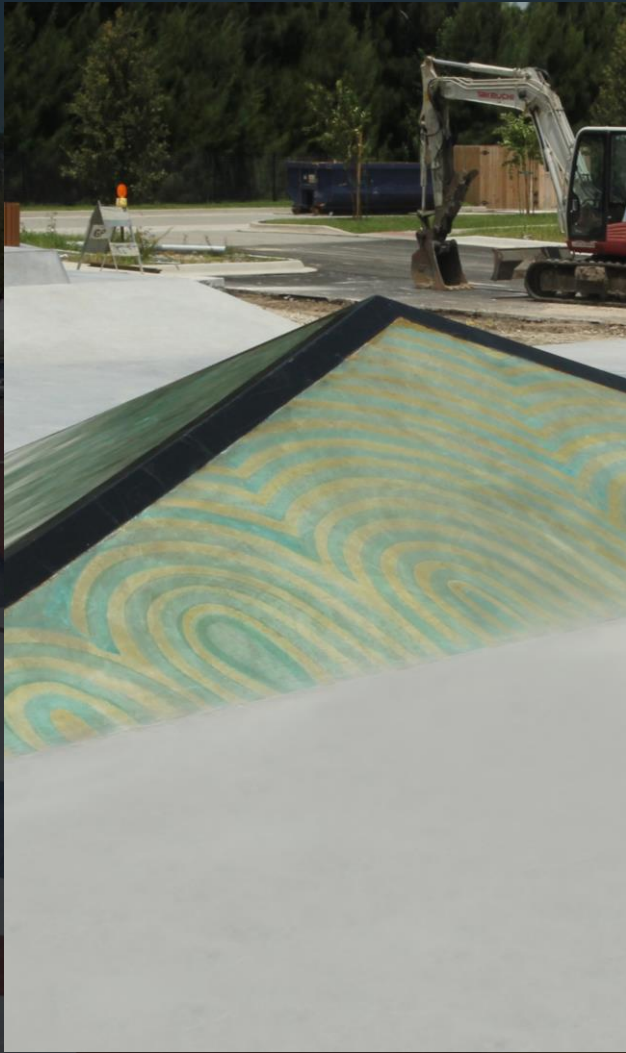



STREET FEATURE EXAMPLES



BOWL EXAMPLES



SNAKE RUN EXAMPLES



TALLAHASSEE, FL

20,000 SF



FREDERICK, CO

30,000 SF

TEAM PAJN
SKATE PARKS



ST. PETERSBURG, FL

28,000 SF

TEAM PAIN
SKATE PARKS



ARVADA, CO

42,000 SF

TEAM PAJN
SKATE PARKS



APEX, NC

18,000 SF

TEAM PAIN
SKATE PARKS



JACKSONVILLE BEACH, FL

23,000 SF

TEAM PAIN
SKATE PARKS



CHARLESTON, SC

33,000 SF

TEAM PAIN
SKATE PARKS

<https://s.surveyplanet.com/ffgqk9nc>

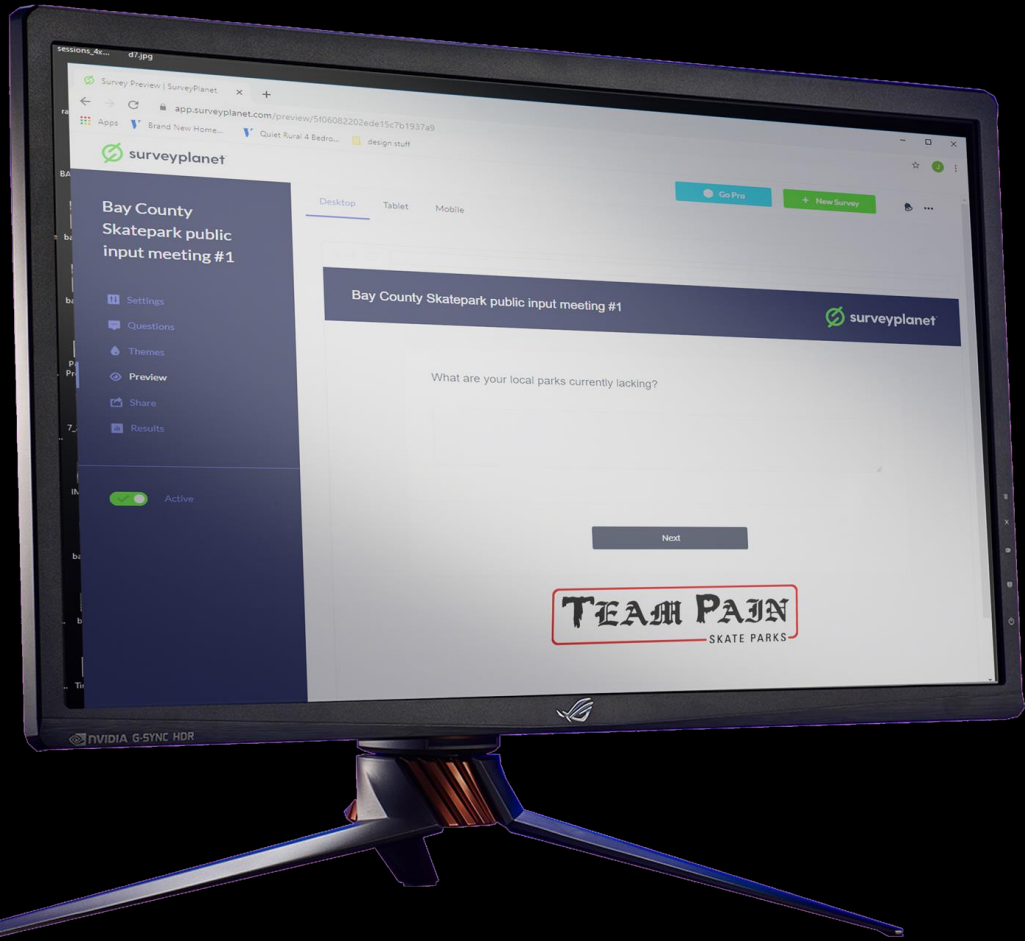

LOG ON
FROM YOUR
COMPUTER
OR
SMART
PHONE



Please visit the survey to help Team Pain understand what specific features you would like to see within the design of the new skatepark.

GENERAL DESIGN QUESTIONS

On a scale from 1-10, please rate the importance(to you) of the following items within a skate park's design. 1 being not important, 10 being very

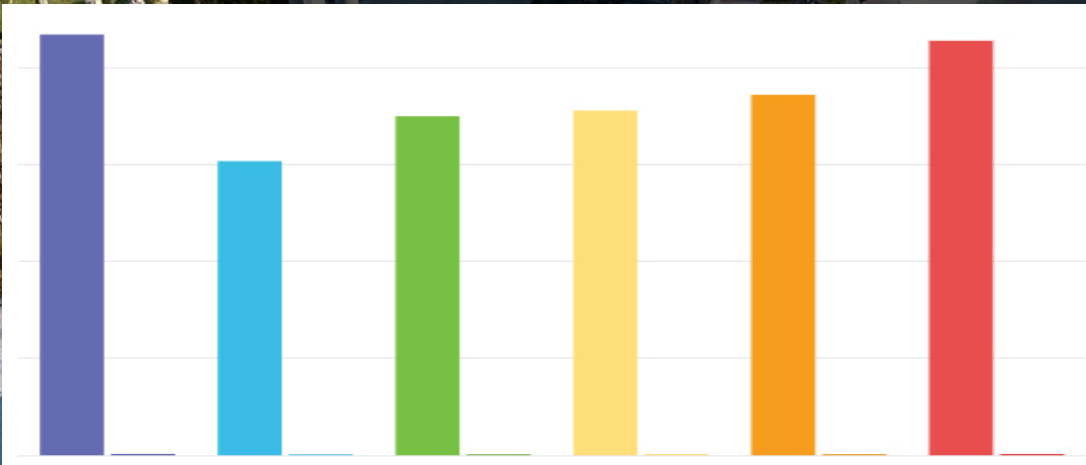

What elements of the current park need to stay?

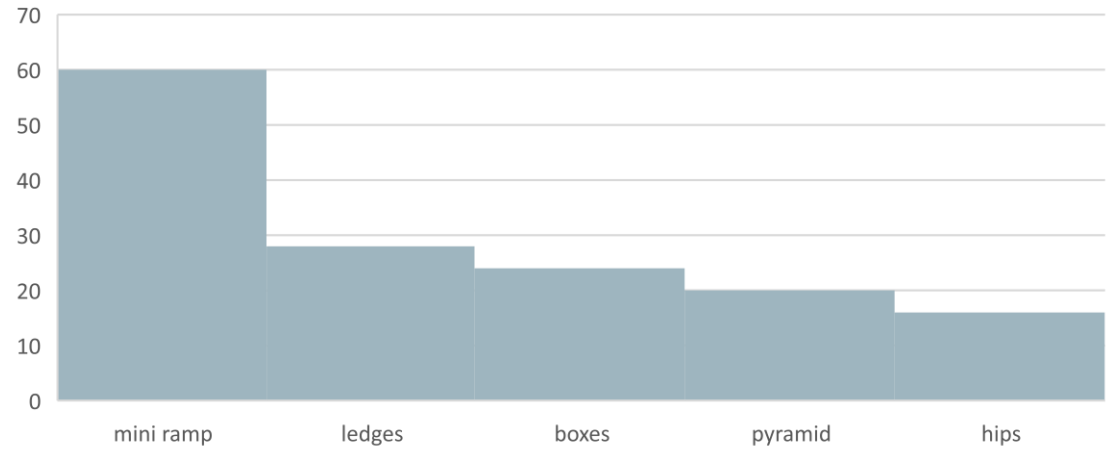

Locals trusted to be consulted for design voted by locals

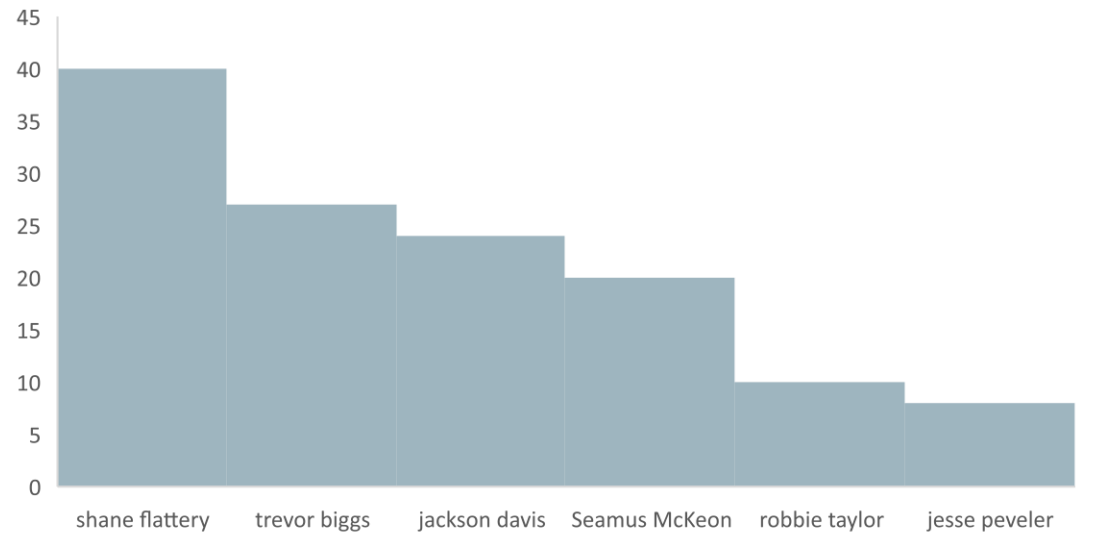

Choice	Score	Average
Street course	2170	6.62
Snake run	1517	4.63
Flow bowl	1749	5.33
Medium bowl	1778	5.42
Beginner area	1859	5.67
Transitional features	2138	6.52

GENERAL QUESTIONS

Are you from

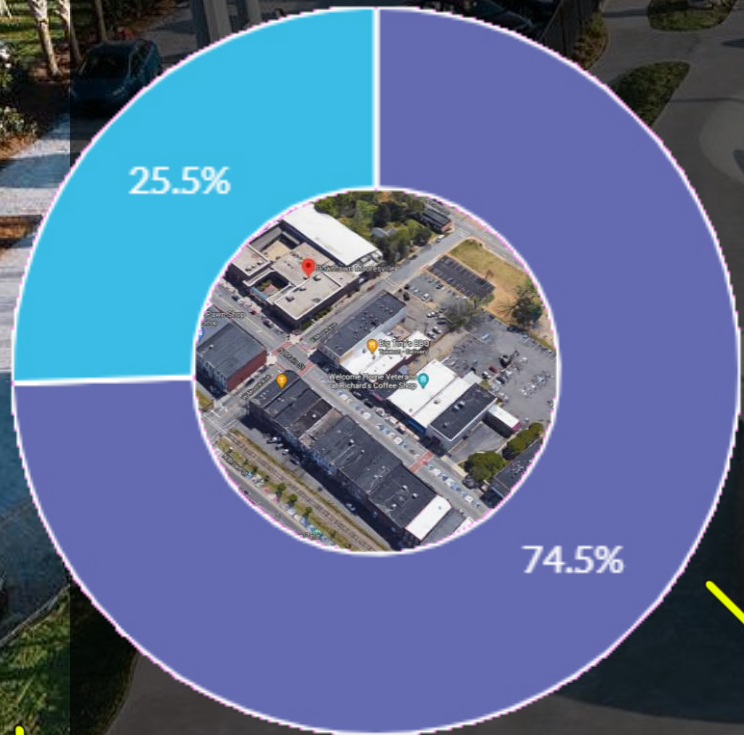

How are you using the local skateparks?

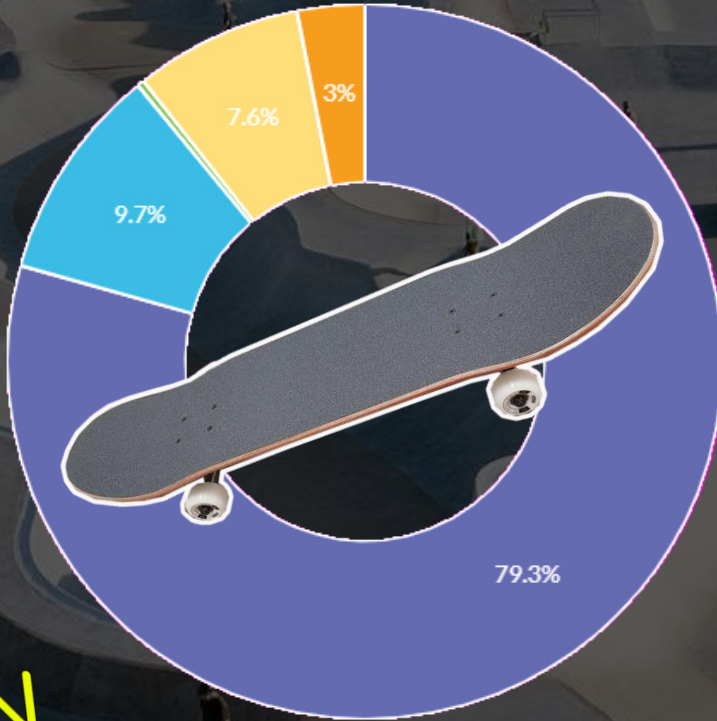

What is your favorite local park?

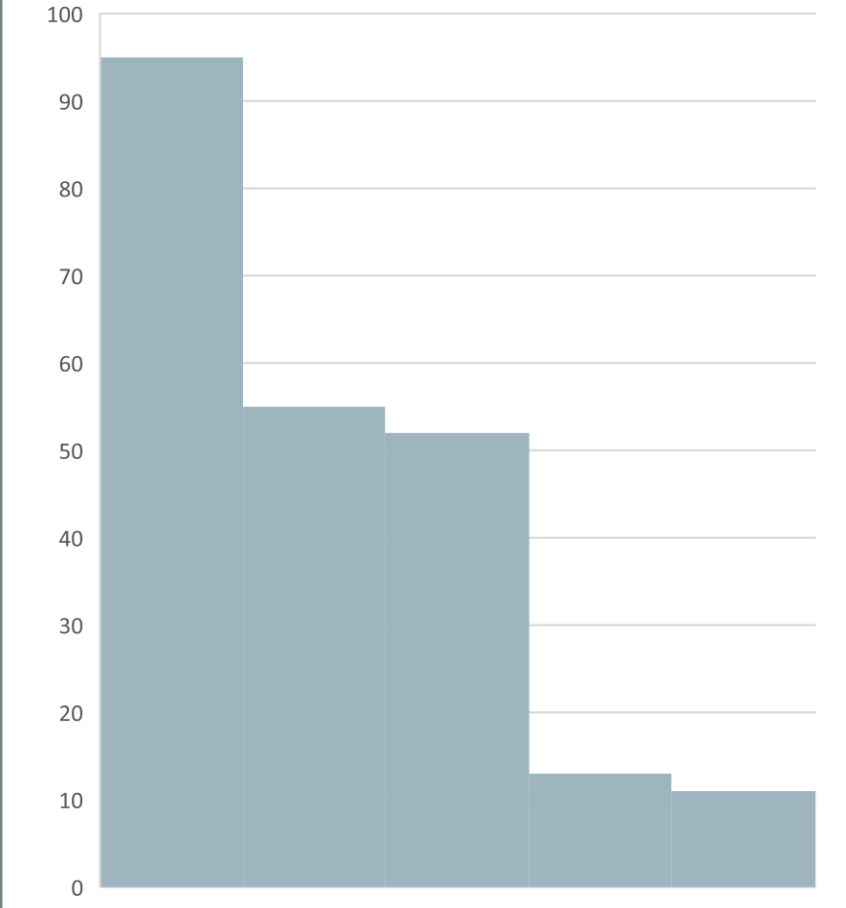

yes	245
no	84

skateboard	261
bicycle	32
quads	1
scooter	25
other	10

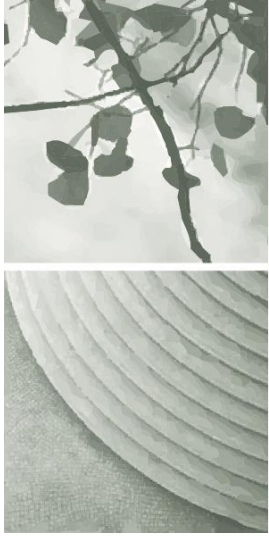

CLAUSON RAWLEY ASSOCIATES INC

landscape architecture . planning . resort design



Stan Clauson, FAICP, ASLA
Planner



Angela Kemp
Planner



Britni Johnson, ASLA, QWEL EPA
Landscape Designer

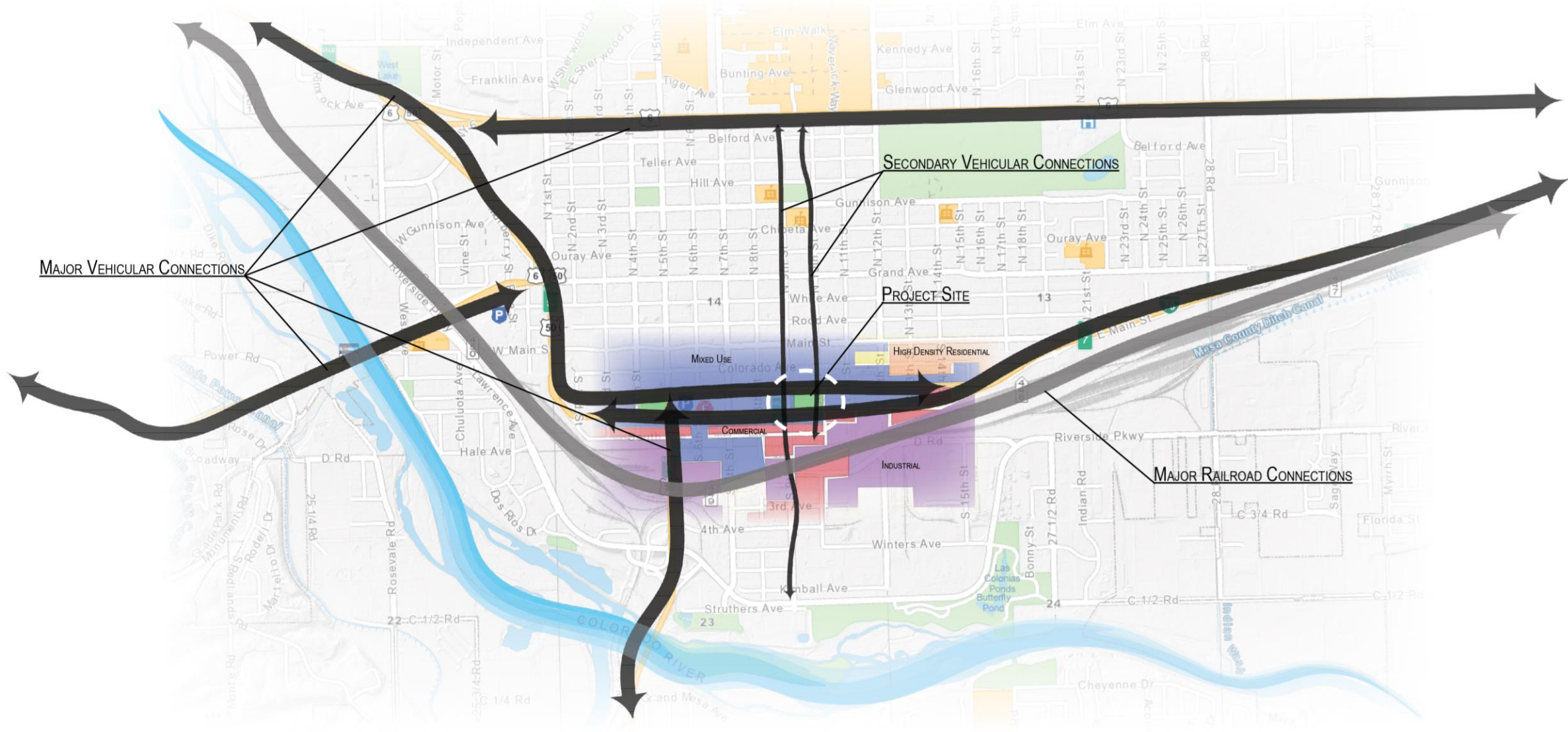

MAJOR VEHICULAR CONNECTIONS

SECONDARY VEHICULAR CONNECTIONS

PROJECT SITE

MIXED USE

HIGH DENSITY RESIDENTIAL

COMMERCIAL

INDUSTRIAL

MAJOR RAILROAD CONNECTIONS

COLORADO RIVER

Mesa County Ditch Canal

Indian Creek

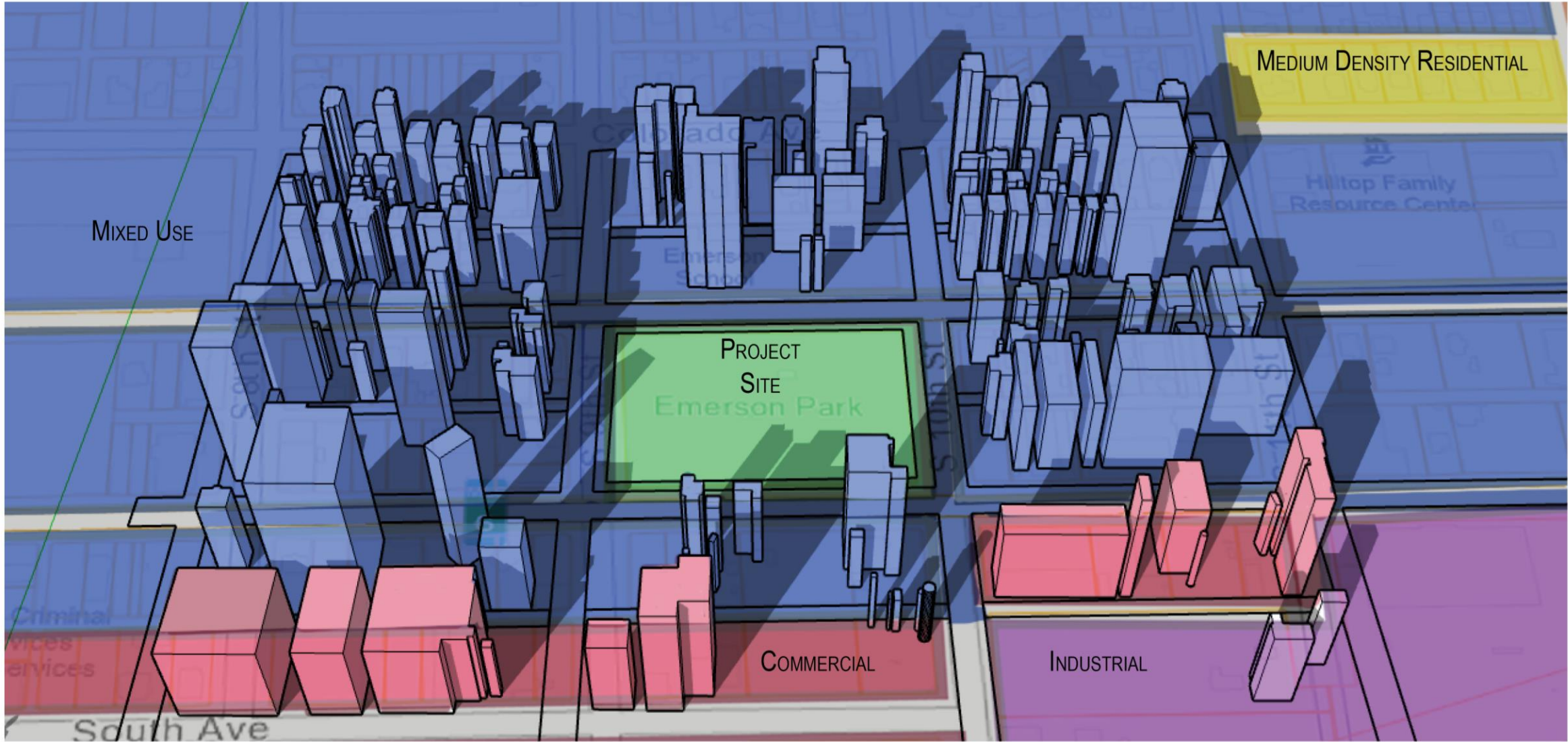

MEDIUM DENSITY RESIDENTIAL

MIXED USE

PROJECT
SITE

Emerson Park

COMMERCIAL

INDUSTRIAL

South Ave

PEDESTRIAN CROSSING IMPROVEMENTS BY OTHERS



POSSIBLE OVERFLOW PARKING



PROPOSED PARKING ENTRANCE SIDE OF THE PARK



PROJECT SITE

VIEWS TO THE RIDGE LINE OF COLORADO NATIONAL MONUMENT

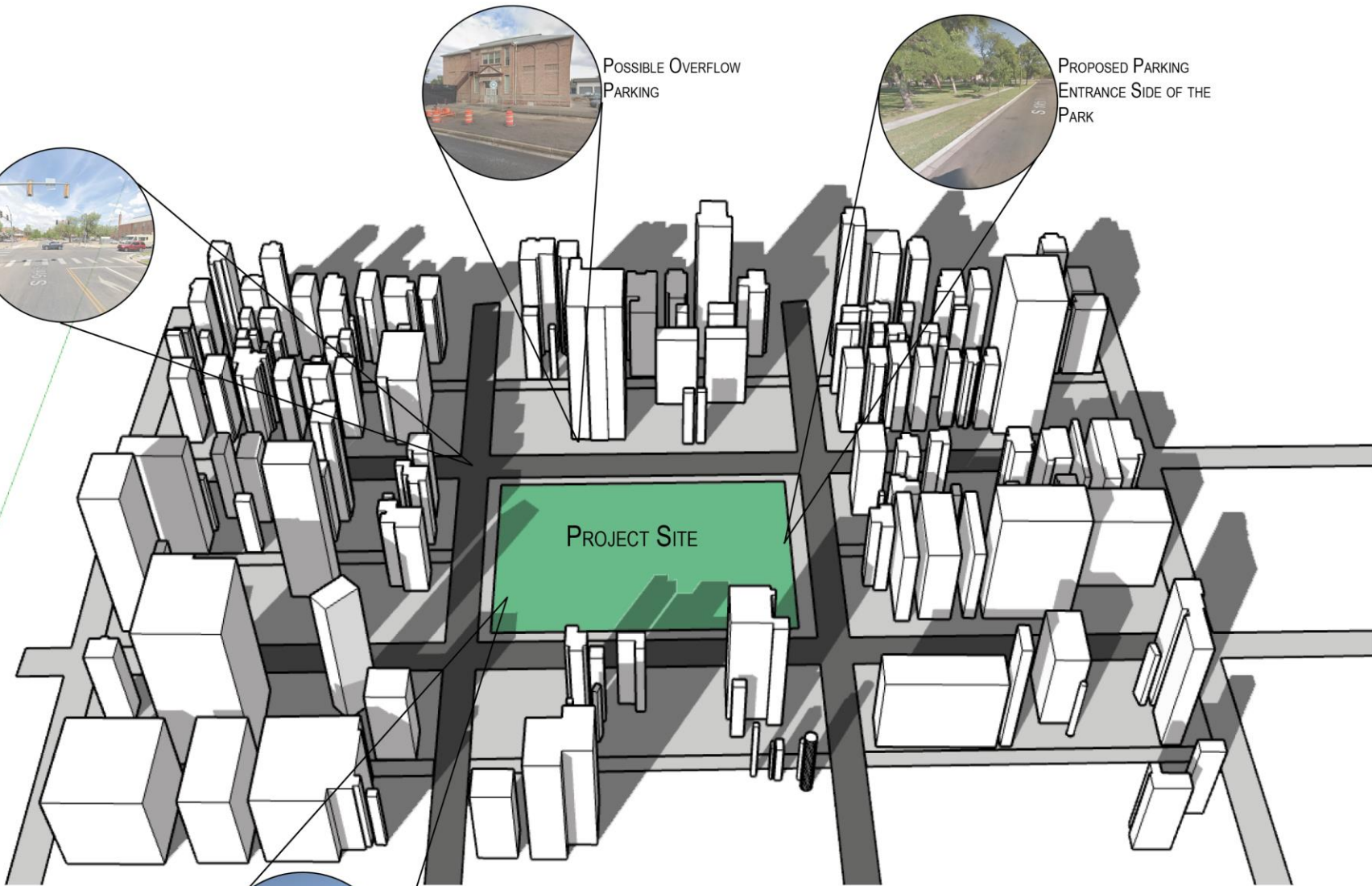



EMERSON PARK

ADDRESS:
 GRAND JUNCTION, CO
 PARCEL #

DATE:
 05.09.2023

ISSUE:
 FOR PLANNING
 PURPOSES ONLY
 NOT FOR CONSTRUCTION

DRAWN BY: BAJ CHECKED BY: PSR

HISTORY:

DATE	ISSUE
0000.0000	

DRAFT

SHEET TITLE:

CONCEPTUAL
 DESIGN
 COMPONENTS

L1.10

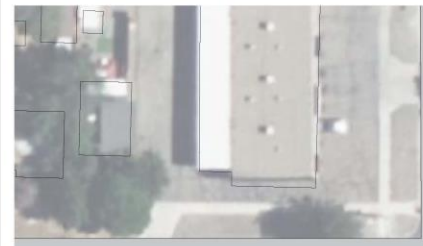

UTE AVENUE



9TH STREET

10TH STREET



PITKIN AVENUE

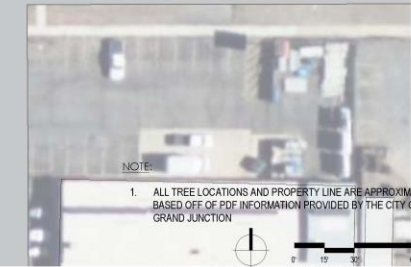

NOTE:

1. ALL TREE LOCATIONS AND PROPERTY LINE ARE APPROXIMATE BASED OFF OF PDF INFORMATION PROVIDED BY THE CITY OF GRAND JUNCTION







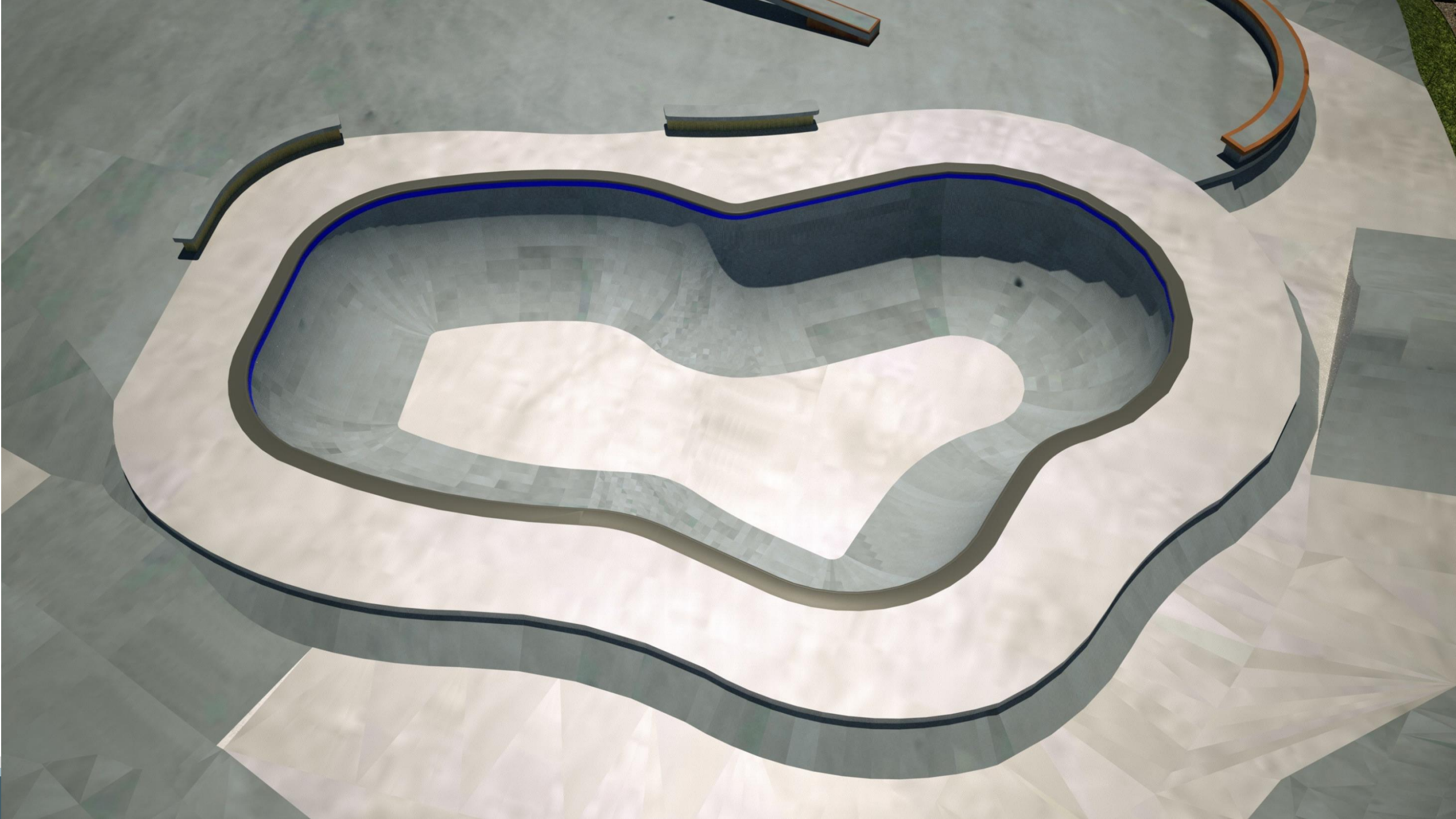

TEAM PAIN

SKATE PARKS

LINK TO SURVEY

<https://s.surveymonkey.com/ffgqk9nc>

THE MEETING WILL BE AVAILABLE FOR ONE WEEK ON YOUTUBE STARTING TOMORROW. ANYONE THAT WAS UNABLE TO ATTEND CAN VIEW THE RECORDING TO HELP WITH FILLING OUT THE QUESTIONNAIRE.

LINK TO ENGAGE GRAND JUNCTION

<https://engagegj.org/emerson-skate-park>

WE WANT YOUR FEEDBACK, SO PLEASE FILL THIS OUT.





INPUT COMMENTS & QUESTIONS

LINK TO SURVEY

<https://s.surveymonkey.com/ffgqk9nc>

LINK TO ENGAGE GRAND JUNCTION

<https://engagegj.org/emerson-skate-park>

CONCEPTUAL DESIGN INPUT MEETING FOR EMERSON PARK SKATEPARK

MAY 9TH, 2023

6 PM Mountain Time

TEAM PAJN

SKATE PARKS

Team Pain Enterprises Inc

890 Northern Way suite D-1
Winter Springs Florida 32708
407-366-9221 office
www.teampain.com

GRAND JUNCTION EMERSON PARK PUBLIC INPUT MEETING 5/9/23

Jaclyn@Team Pain to Everyone 08:00 PM

Hello! Welcome to the Grand Junction Public Meeting

Jaclyn@Team Pain to Everyone 08:01 PM

Please send your questions and comments during the meeting here.

Jaclyn@Team Pain to Everyone 08:03 PM

We will be sending a survey for everyone to fill out. Tomorrow we will have the meeting and a link to the survey on EngageGJ.org

mary to Everyone 08:05 PM

Thank you.

Jaclyn@Team Pain to Everyone 08:09 PM

Please send your questions and comments during the meeting here :)

mary to Everyone 08:10 PM

I would like to know if there will be a separate area for beginners and those who are more experienced. I have brought my young children to try out the skate park in Long Park and we don't quite feel safe sharing the space.

JesseBoyden88 to Everyone 08:13 PM

Love the art!

Team Pain Admin to Everyone 08:14 PM

Hey Mary thanks for joining that is definitely a possibility. We want everyone's input to be included into the design.

Loren Griffeth to Everyone 08:15 PM

Yeah, just moved over from Arvada last year

Gunner to Everyone 08:16 PM

Team pain does it well 🙌

Jaclyn@Team Pain to Everyone 08:16 PM

Thank you!

Jon Casson to Everyone 08:17 PM

I worked with Team Pain on the Steamboat Springs park. They did great work then and their parks have only gotten better and more creative since.

JesseBoyden88 to Everyone 08:17 PM

Loving the snake run

Ryan Sylvester to Everyone 08:20 PM

What is the proposed size of the Emerson Skate park so we can compare to the square footage of the examples being shown?

Team Pain Admin to Everyone 08:21 PM

Thank you Jon!

Jaclyn@Team Pain to Everyone 08:21 PM

Hi Ryan. This is a concept development process to determine the size and type of park.

Jaclyn@Team Painto Everyone 08:23 PM

LINK TO SURVEY

<https://s.surveyplanet.com/ffgqk9nc>

Jaclyn@Team Painto Everyone 08:23 PM

LINK TO ENGAGE GRAND JUNCTION

<https://engagegj.org/emerson-skate-park>

Jaclyn@Team Painto Everyone 08:26 PM

Tomorrow the City will post a link to the survey and YouTube video of this meeting. Please share with your friends who could not make it.

Josh Castaneda to Everyone 08:27 PM

Thanks Jaclyn 🙌

Jaclyn@Team Pain to Everyone 08:28 PM

You're welcome Josh!

Loren Griffeth to Everyone 08:28 PM

Can't fully express how happy I am that this is happening. Team Pain is the absolute best

Jon Casson to Everyone 08:29 PM

GJ gets hot in the summer...any thoughts on lights for the summer months?

Jaclyn@Team Pain to Everyone 08:29 PM

Hi Jon! Make sure you include lighting in your survey response

Jaclyn@Team Pain to Everyone 08:30 PM

LINK TO ENGAGE GRAND JUNCTION

<https://engagegj.org/emerson-skate-park>

Gunner to Everyone 08:31 PM

Lights

JesseBoyden88 to Everyone 08:32 PM

Let's build triple story. Parking garage on top. Snake run to the bottom. Full pipe. All iconic objects. Lost of lights. The whole nine yards. Haha! 🤪

Chani Smith to Everyone 08:33 PM

Grand Junction has been missing TEAM PAIN. You guys being involved is an answer to over 20 years of prayer. I trust that no matter what y'all do in my hometown will be amazing!

Jaclyn@Team Pain to Everyone 08:33 PM

Aww thank you Chani !

Chani Smith to Everyone 08:35 PM

That's a great idea, Jesse! It would solve the parking challenges and provide protection from the weather and squelching sun!

Loren Griffeth to Everyone 08:35 PM

Please don't let whoever did the graffiti at Eagle Rim park do any graffiti on this one!!!!

JesseBoyden88 to Everyone 08:35 PM

Love those transfers and gaps!

JesseBoyden88 to Everyone 08:35 PM

I love those transfers and gaps!

JesseBoyden88 to Everyone 08:36 PM

Arvada is sick!!!

Chani Smith to Everyone 08:39 PM

Amen Jon!! Great comments!

Loren Griffeth to Everyone 08:39 PM

No matter what they put in will be rad

JesseBoyden88 to Everyone 08:40 PM

Flow master Sale! Haha 😊

Chani Smith to Everyone 08:41 PM

There is NO smooth vert at all!

Jaclyn@Team Pain to Everyone 08:42 PM

LINK TO SURVEY

<https://s.surveypal.com/ffgk9nc>

Loren Griffeth to Everyone 08:43 PM

Maybe a couple bowls, one deep and one shallower, or a shallow end would work, too. Just don't forget to have soJaclyn@Team Pains shallower end stuff please! Mini ramper for life!!!

JesseBoyden88 to Everyone 08:44 PM

Vert wall. Like ninja warrior. 30' tall 😊

Chani Smith to Everyone 08:44 PM

I know St. Augustine, FL is an older park. It has those deep and shallow bowls and the roll into the street hips are super flow! That was your park, right Tim?

Jaclyn@Team Pain to Everyone 08:45 PM

Yes! That is one our oldest parks!

Team Pain Admin to Everyone 08:46 PM

Yes we did the St. Augustine Skate Park Chani !

Loren Griffeth to Everyone 08:46 PM

Emerson Park's not too far from the train tracks, so Jaclyn@Team Pains sort of a railroad track feature would be rad. Maybe a gap in a transition with a railroad track going across

Josh Niernberg to Everyone 08:46 PM

^^^ great idea^^^

Ryan Sylvester to Everyone 08:46 PM

Ya

Jaclyn@Team Pain to Everyone 08:47 PM

Ryan did you still have a question?

Jaclyn@Team Pain to Everyone 08:47 PM

Please feel free to jump in

Loren Griffeth to Everyone 08:47 PM

Definitely a covered pavillion area would be great for that

Ryan Sylvester to Everyone 08:48 PM

I think my mic isn't working - I just wanted to first of all say how stoked and excited we are to have Team Pain in Grand Junction! Thanks to Ken and Parks and Rec to colaborate with you guys!

Loren Griffeth to Everyone 08:48 PM

A monument or a mesa feature would be awesome

Chani Smith to Everyone 08:48 PM

I do want to say that excellent spectator accommodations is a must for a healthy park ecosystem. It also helps keep the riff ruff down which is probably going to be essential with that site.

Ryan Sylvester to Everyone 08:49 PM

I think what's truly important is to consider that we may not please everyone with this skatepark but the more unique we can make it the more it will draw travelling skaters and park riders into Grand Junction

JesseBoyd88 to Everyone 08:49 PM

Yeah. The grand valley... Snake run..

Loren Griffeth to Everyone 08:49 PM

We need to grind!!!!!!!!!!!!!! COping!!!!!!!!!!

Ryan Sylvester to Everyone 08:49 PM

But a practical question - what is the timeline - when are you trying to have the final design done?

Team Pain Admin to Everyone 08:49 PM

Please take a moment to fill out the survey if you haven't yet

Jaclyn@Team Pain to Everyone 08:50 PM

LINK TO SURVEY

<https://s.surveyplanet.com/ffgqk9nc>

Jaclyn@Team Pain to Everyone 08:50 PM

The video and link to the survey will be posted tomorrow on engagegj.org

Jaclyn@Team Pain to Everyone 08:51 PM

please share with everyone who may have missed the meeting

TeamPain to Everyone 08:53 PM

<https://www.youtube.com/watch?v=YKG9XOKFAV4>

Jon Casson to Everyone 08:53 PM

Chin Ramp replica! :)

Emily Krause to Everyone 08:56 PM

Could we please ask all in attendance to please leave their email in the chat so we can add them to our future communication emails - Thanks!

Loren Griffeth to Everyone 08:56 PM

lorengriffeth1@gmail.com

Jon Casson to Everyone 08:56 PM

jon.boardcoach@gmail.com

Laurel to Organizer(s) only 08:56 PM

laureljtiffany@gmail.com

JesseBoyden88 to Everyone 08:57 PM

Thanks Team Pain and GJ City! Huge smile on my face 😁! Special shout out to Chani Smith. WASA team! Jonny Sale... Great commentary!

Popper to Everyone 08:59 PM

For Ken. GJ would be a great tourist hub for skaters and families all the way out from Moab to Telluride to Denver. Even beyond. Easy. Team Pain parks are a huge tourist attraction. The economic impact will be significant.

JesseBoyden88 to Everyone 09:01 PM

Add some positive messages to the art obstacles.

Loren Griffeth to Everyone 09:02 PM

Popper, that's a great point. Team Pain parks are a destination. This park would absolutely bring revenue into town. Grand Junction has such an opportunity to be a place for people to stop in on their way to wherever

Team Pain Admin to Everyone 09:03 PM

LINK TO SURVEY

<https://s.surveyplanet.com/ffgqk9nc>

JesseBoyden88 to Everyone 09:03 PM

😘 🎉 Love those kiddos 🙌 🍷 ❤️ 👍 us

Jon Casson to Everyone 09:04 PM

Gotta leave, but so stoked on this project!!

Popper to Everyone 09:08 PM

From 8 to 80, skaters are all Mutual Friends!

Chani Smith to Everyone 09:10 PM

Great comment!

JesseBoyden88 to Everyone 09:12 PM

Friday SK8 sesh. OM 5pm...??

Loren Griffeth to Everyone 09:13 PM

Absolutely!

Loren Griffeth to Everyone 09:13 PM

Such a good point, Britni

Loren Griffeth to Everyone 09:16 PM

My brother in law owns an electrical business here in town. I'm gonna try to talk him into doing a system for cheap

Jaclyn@Team Pain to Everyone 09:17 PM

If anyone fills out the survey and remembers they forgot to add something, shoot us an email at info@teampain.com

Popper to Everyone 09:20 PM

Spalling typically occurs when the rebar starts to rust and expand.

Jaclyn@Team Pain to Everyone 09:21 PM

It happens when over finishing with a machine trowel. We mostly hand finish our concrete.

Chani Smith to Everyone 09:23 PM

Thanks for having this open forum! Great meeting. Super exciting.

Ryan Sylvester to Everyone 09:24 PM

Thanks so much Team Pain and GJ Parks&Rec! We look forward to the next meeting. Have a good night

Team Pain Admin to Everyone 09:26 PM

Don't forget to take the survey thanks everyone !

<https://s.surveypal.com/ffgqk9nc>

Isaac to Everyone 09:26 PM

intheimagemusic@me.com

Josh Niernberg to Everyone 09:26 PM

Thank you all. Thanks Team Pain, Ken, Emily and Parks and the CRA crews. We have been trying to see this day come fruiting for a looong time. Its very exciting.

Isaac to Everyone 09:28 PM

Joe and Josh Reed are gonna be psyched!

Isaac to Everyone 09:28 PM

Thanks guys!

Chani Smith to Everyone 09:28 PM

Buck is famous... again! Haha

Laurel to Organizer(s) only 09:29 PM

Thank you so much!! Super excited!!

Josh Castaneda to Everyone 09:29 PM

Thanks for all the time and effort from all party's. We are so excited and can't wait to be a part of this epic park. Thanks to Tim, Jaclyn, the team pain team, city of GJ and CRA. You rule 🙌

Popper to Everyone 09:29 PM

Josh and Jonny, you guys rock. Props



CONCEPTUAL DESIGN
PRESENTATION
FOR
EMERSON PARK
SKATEPARK

JULY 27TH, 2023
6 PM Mountain Time

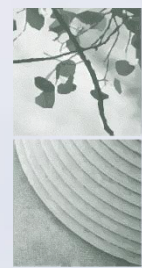

CLAUSON RAWLEY ASSOCIATES INC
landscape architecture. planning. resort design



TEAM PAJN
SKATE PARKS



- 30+ YEARS SKATE PARK DESIGN & CONSTRUCTION EXPERIENCE
- CUSTOM, POURED IN PLACE CONCRETE SKATE PARKS
- RECOGNIZED FOR FIRST EVER STRUCTURES
- PROJECTS WORLD-WIDE
- MUNICIPAL GOVERNMENT EXPERIENCE
- EXTENSIVE INDUSTRY EXPERIENCE
- PRESTIGIOUS PUBLICATIONS & AWARDS

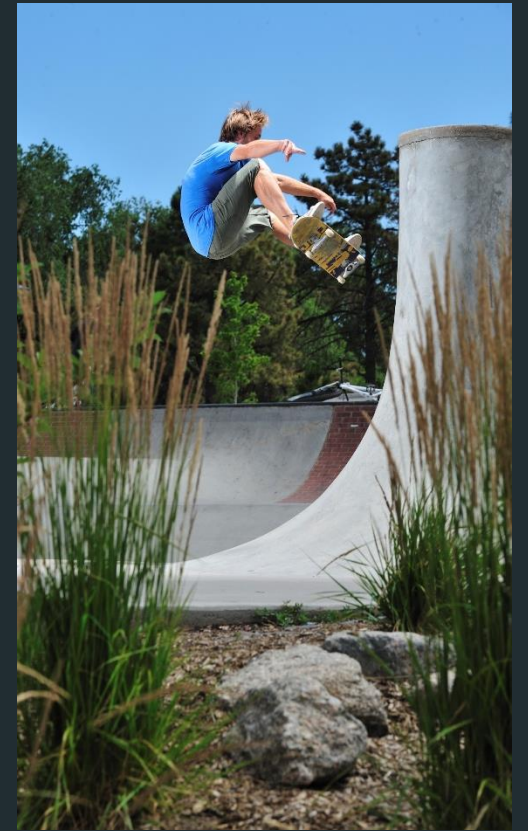

COLORADO EXPERIENCE



26 SUCCESSFUL CONCRETE SKATEPARKS IN
COLORADO



CLAUSON RAWLEY ASSOCIATES INC
landscape architecture.planning.resort design

JOINED TEAM PAIN FOR THE
ASPEN SKATEPARK - FUTURE PHASE 2 EXPANSION



WORKED WITH TEAM PAIN ON 10 CONCRETE SKATE
PARKS IN COLORADO

TEAM PAIN SKATEPARKS COLORADO STATE SKATEPARK MAP

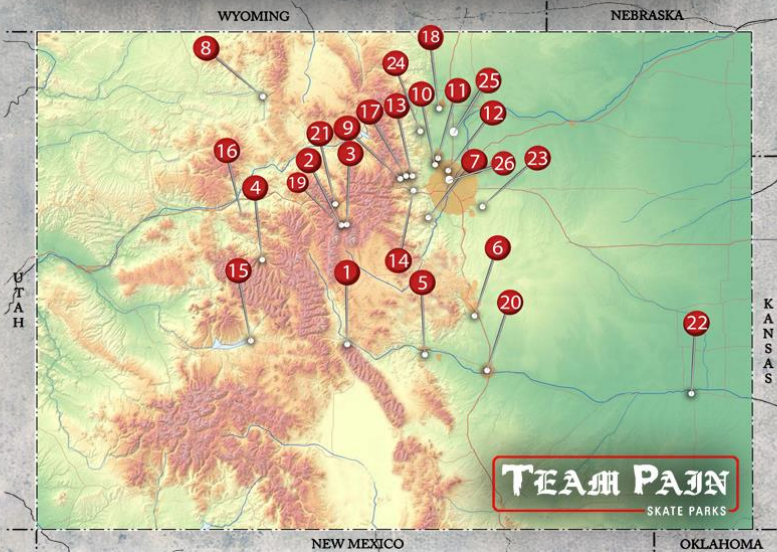

COMMUNITY MEETING #1

OUR TEAM HOSTED A VIRTUAL PUBLIC MEETING WITH OVERWHELMINGLY POSITIVE AND ROBUST FEEDBACK!



- WITH A 2 MONTH TURN AROUND, WE WERE ABLE TO PROVIDE MORE FEEDBACK IN AN ACCELERATED TIMELINE.
- WE PROVIDED A URL LINK WITH SURVEY QUESTIONNAIRE.
- WE UPLOADED THE MEETING TO YOUTUBE AND PUSHED THE SURVEY ON SOCIAL MEDIA AND THROUGH ENGAGEJ.COM TO GAIN MORE REACH AND FEEDBACK
- WE HOSTED REVIEW SESSIONS WITH THE SKATE AND BMX COMMUNITY IN GRAND JUNCTION





MATURE TREE
INTEGRATION

EXAMPLE PROJECT – CASSELBERRY, FL
39,520 SQ. FT.

Urban Forester



- The Tree survey was conducted by City of Grand Junction Urban Forester where each tree's species and size were inventoried. The survey included - Species, caliper size, root zone, canopy overhang, health/condition/viability.

SURVEY RESULTS

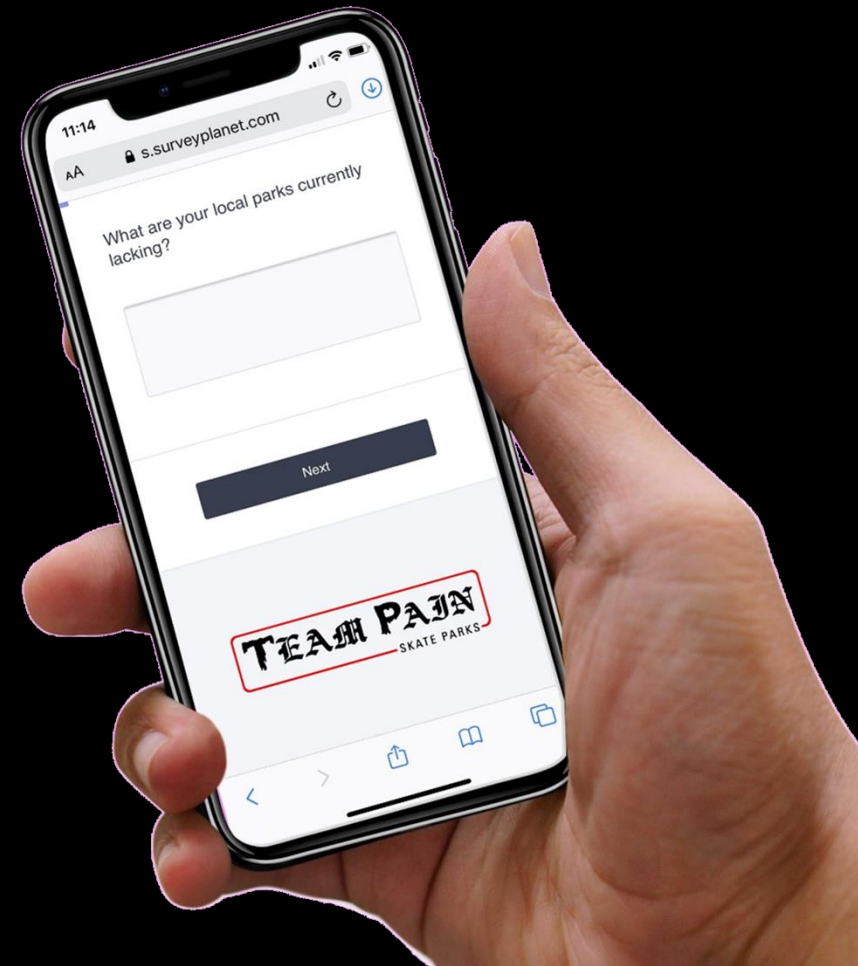
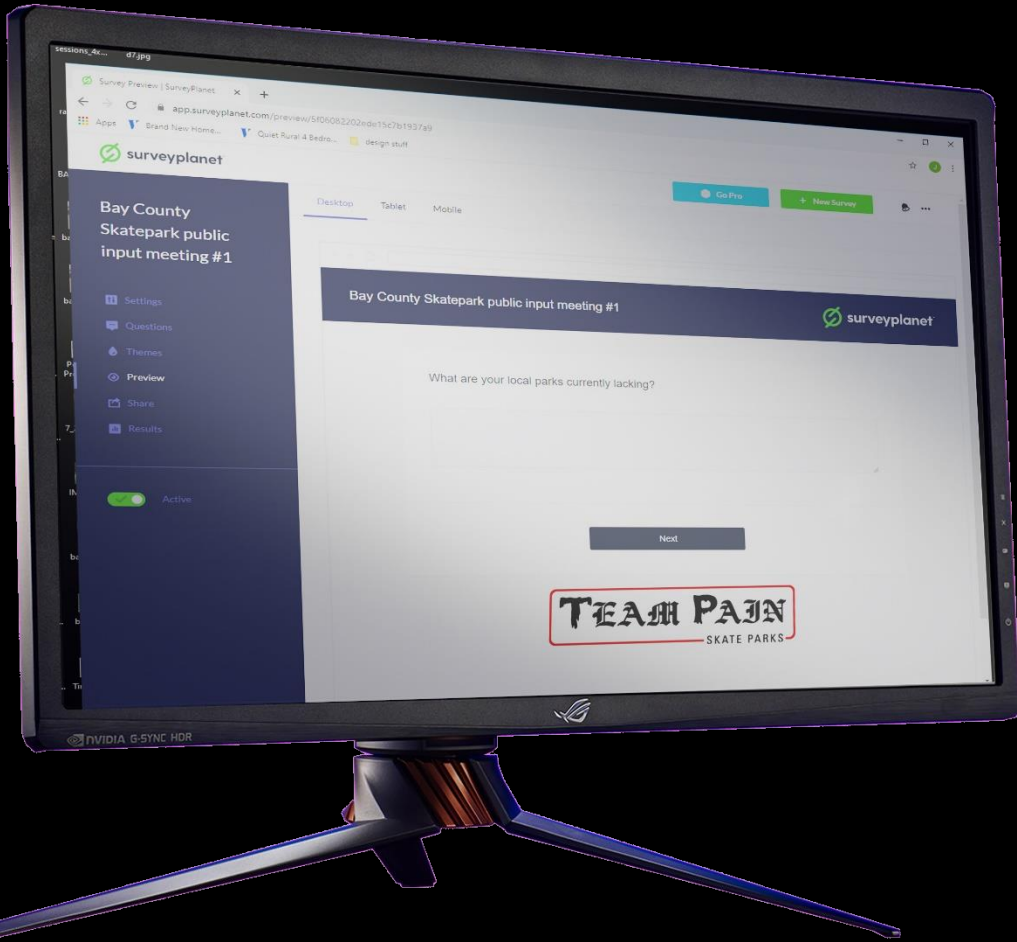

Grand Junction Survey

147

Responses Since
Apr 19

Responses Today
0



Inactive

Q1 Do you live in Mesa County?

- Yes 139
- No 8

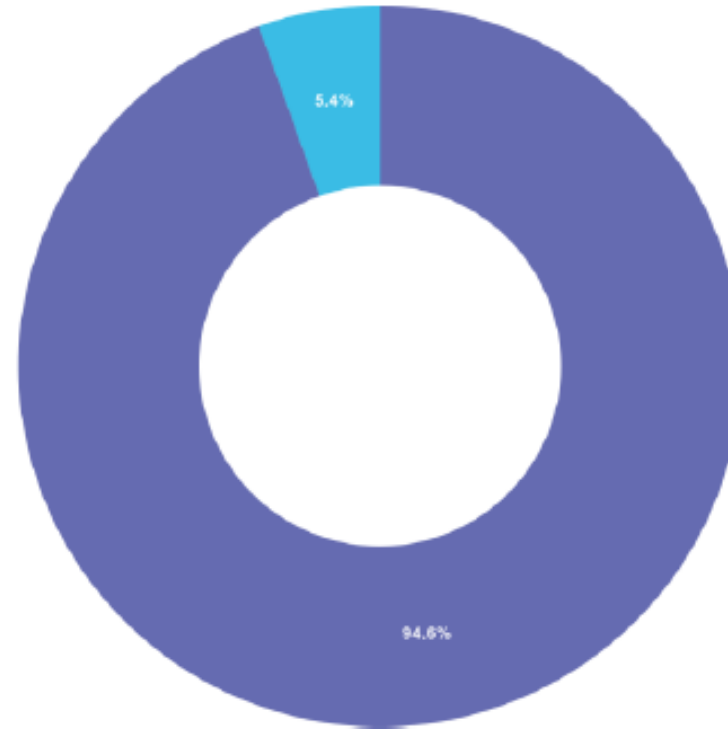

Q3 How would you get to Emerson Park?
(car, bike, walk, scooter or board)

•	Car	112
•	Bike	14
•	Walk	7
•	Scooter	0
•	Skateboard	14

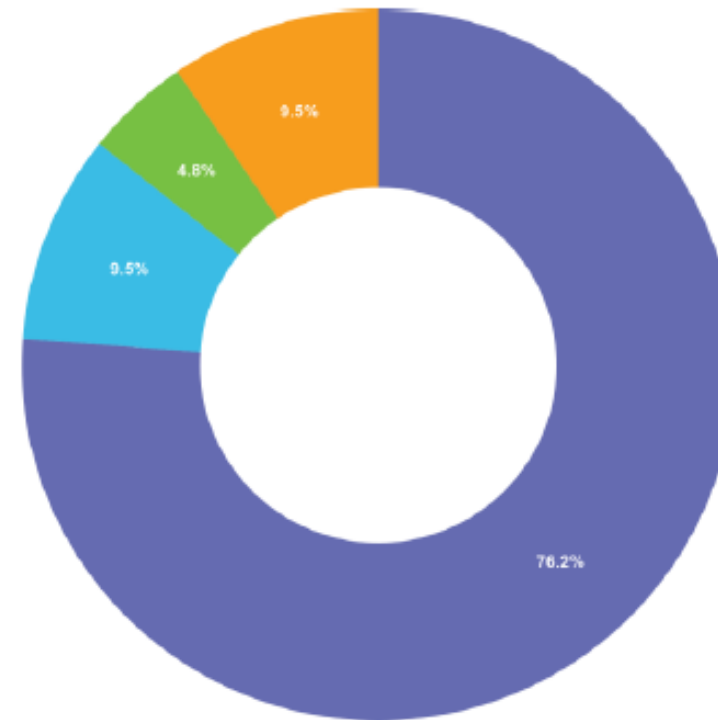

Q9 Do you prefer street elements or transition type elements?

- Mostly Street (stairs,ledges,rails) 13
- Mostly Transition (Quarter Pipers, Banks, Bowls/Pools) 41
- Mix of both 93

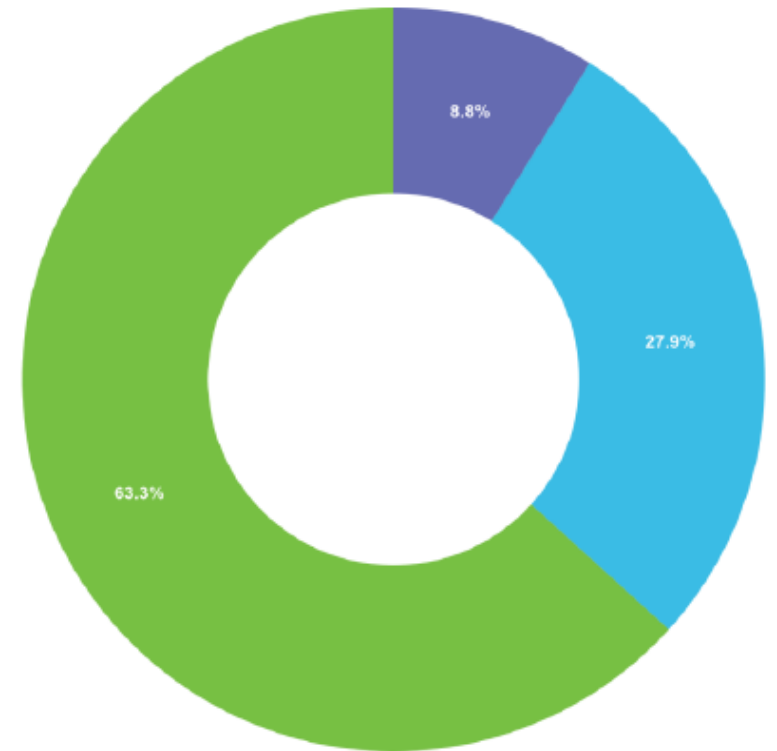

Q10 Do you prefer square rails or round rails?

- Both 63% wants Both

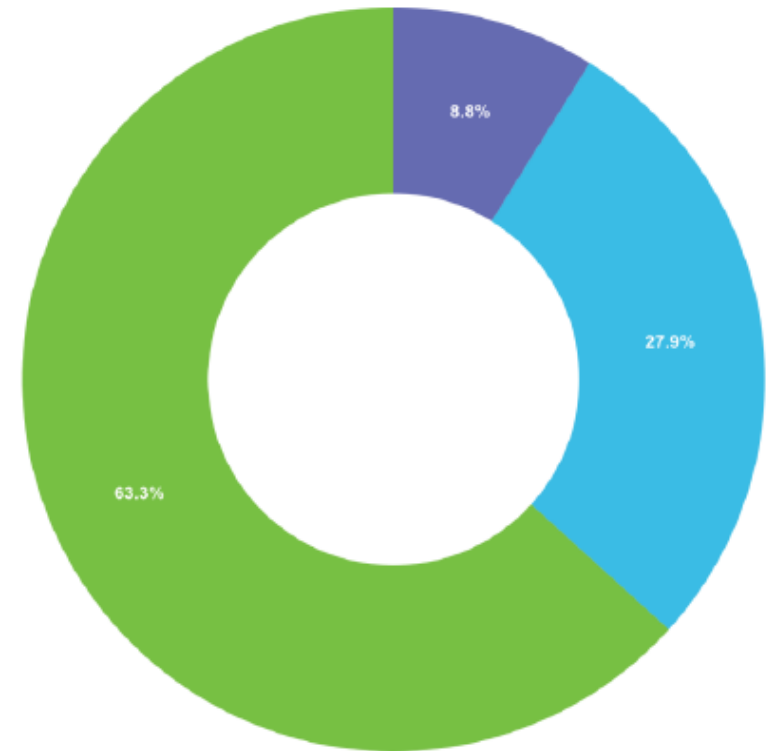

Q14 Do you like stairs?

- Yes 87

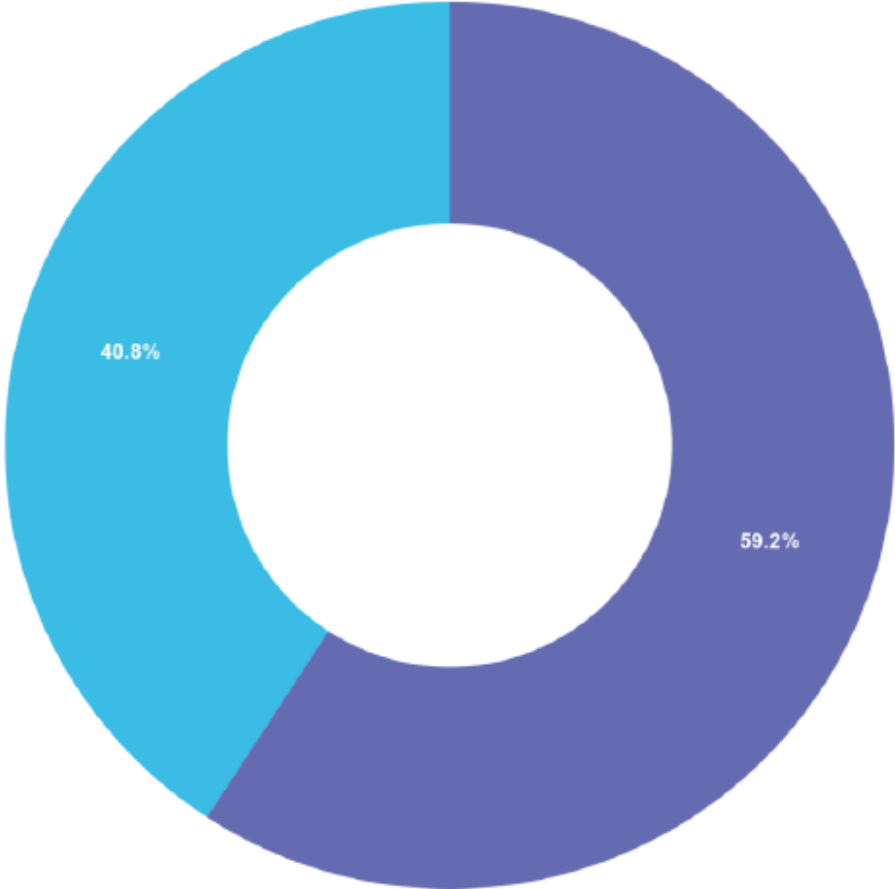

Q16 Do you feel that contests and events at public parks are important?

86.4 percent said yes! Contests are important

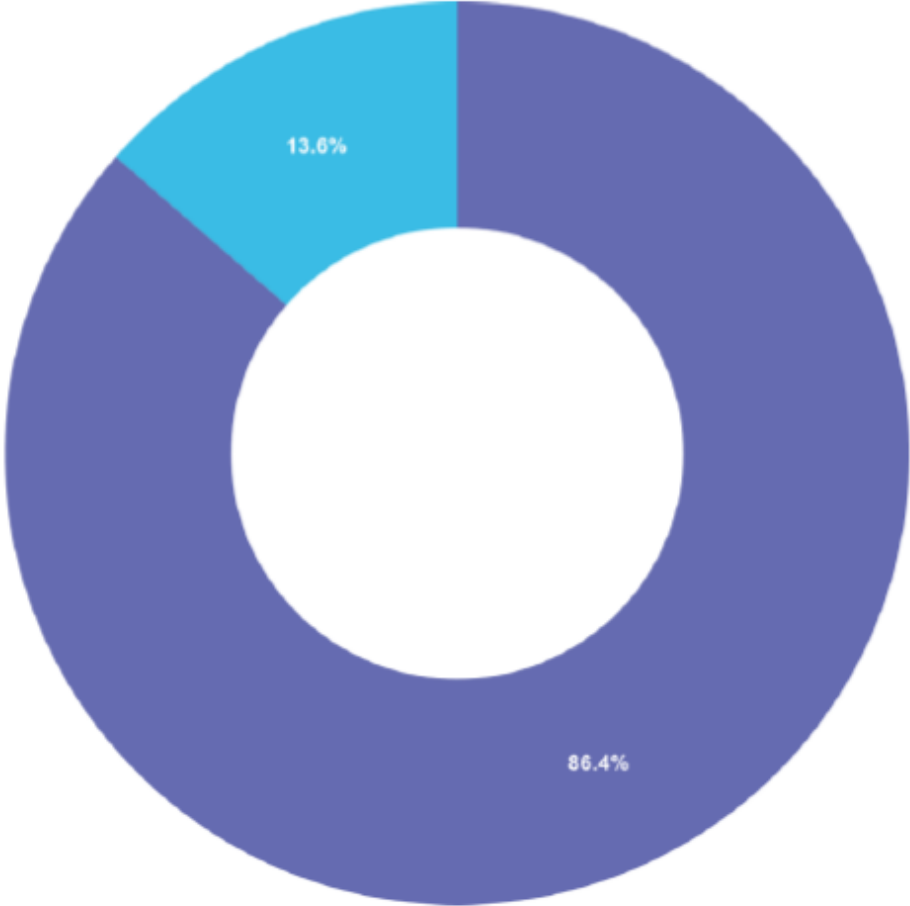

Want bowls with pool coping and tile 10 ft deep



Q27 Is flat ground skating important to you?

70% like plaza style street areas with

- Stairs
- Euro Gaps
- Handrails
- Ledges
- Unique features
- Brick Stamping
- Colored Concrete
- Skatable walkways with slappy curbs

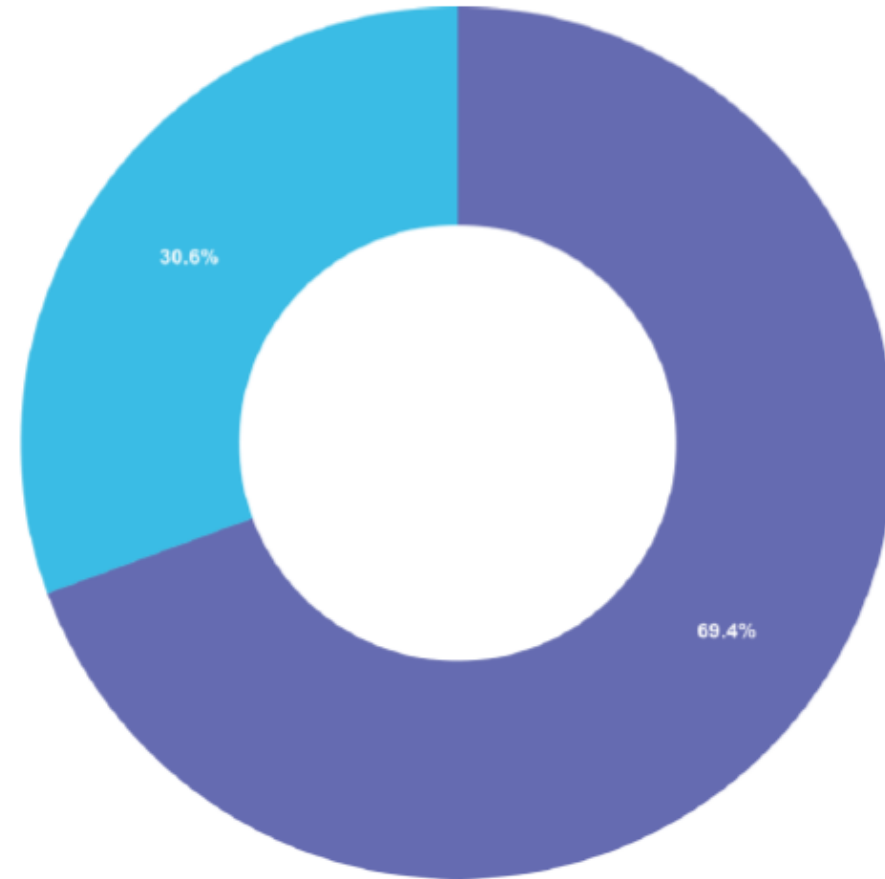



10TH STREET

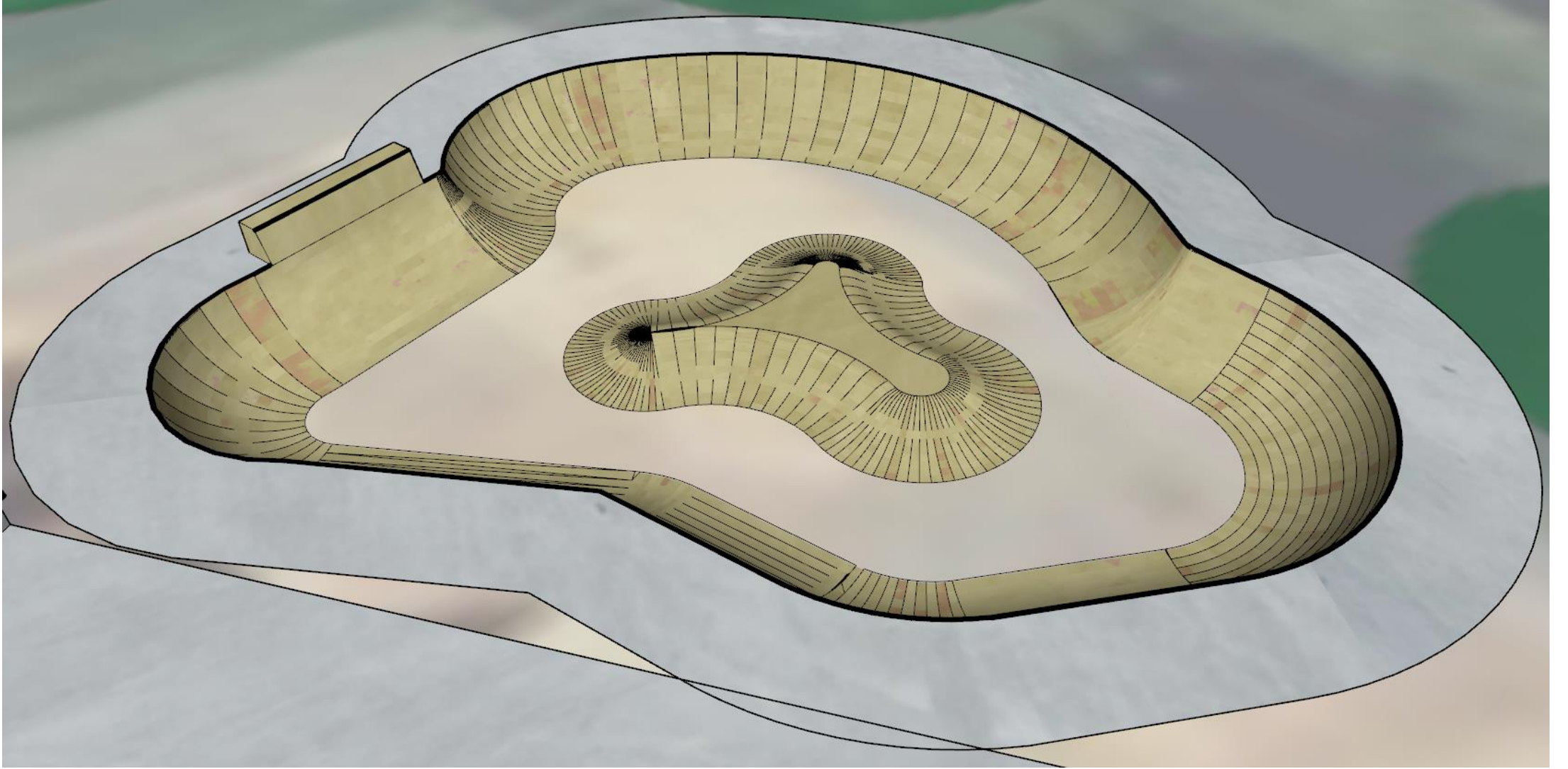



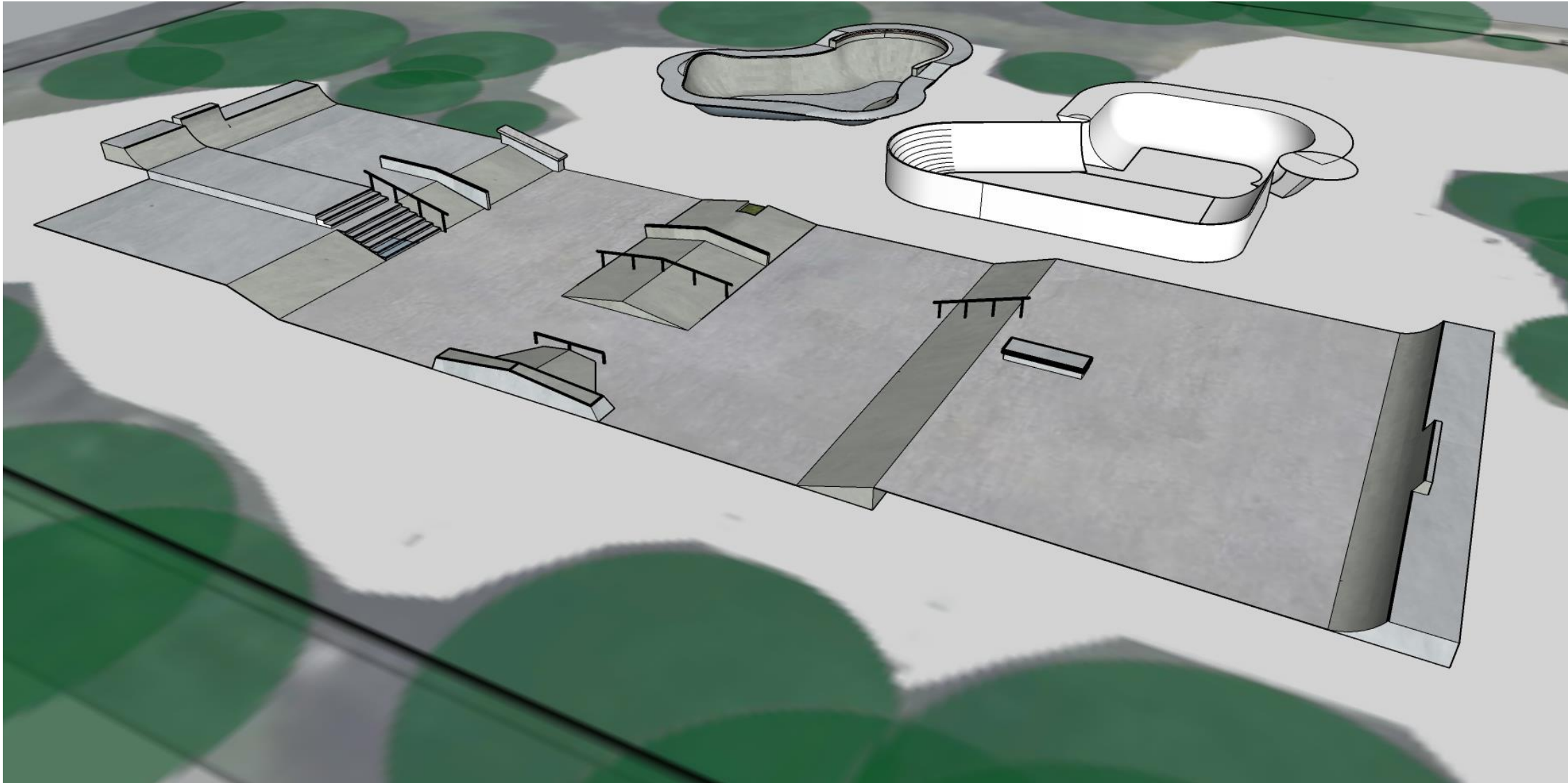

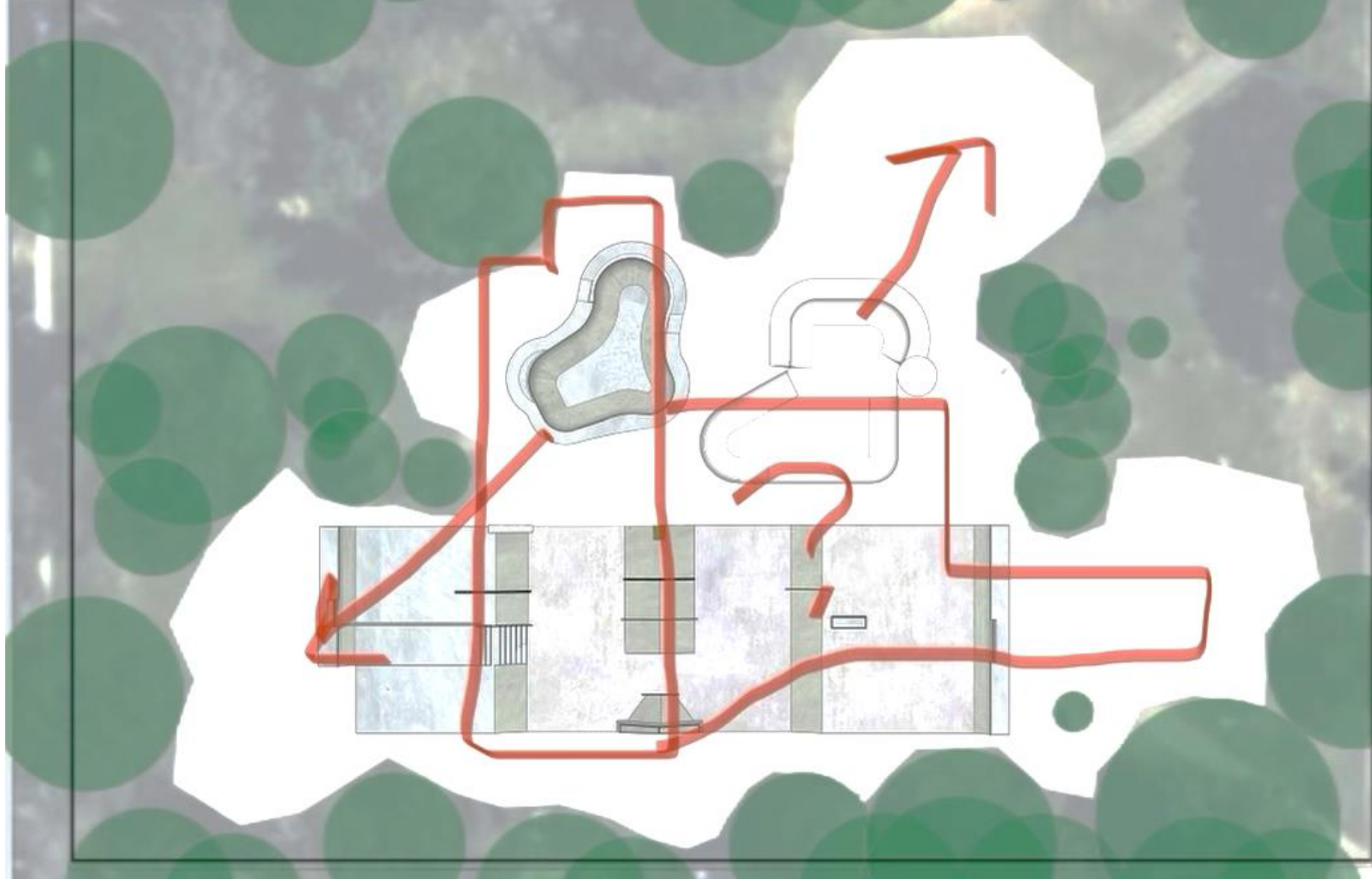

17TH STREET

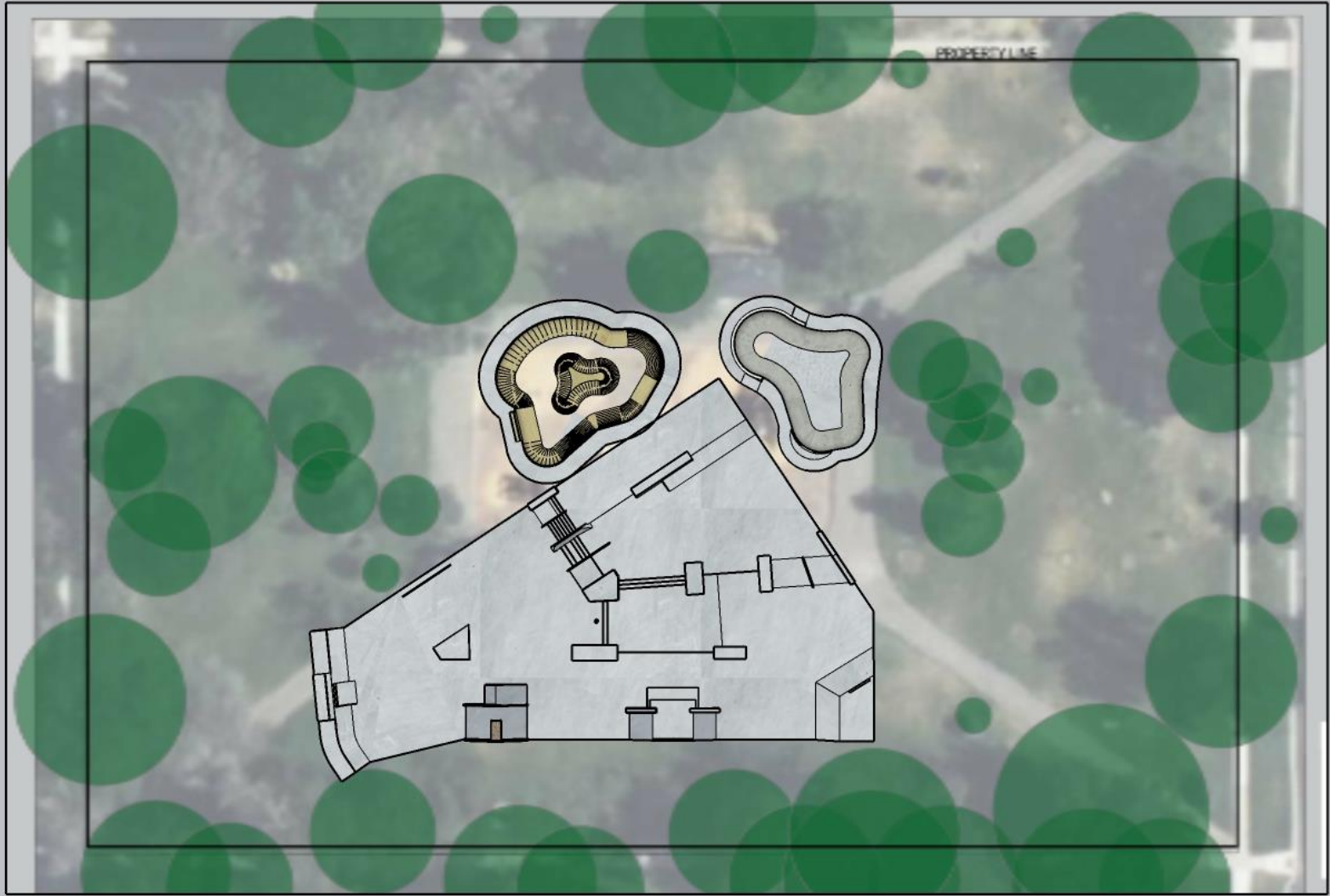

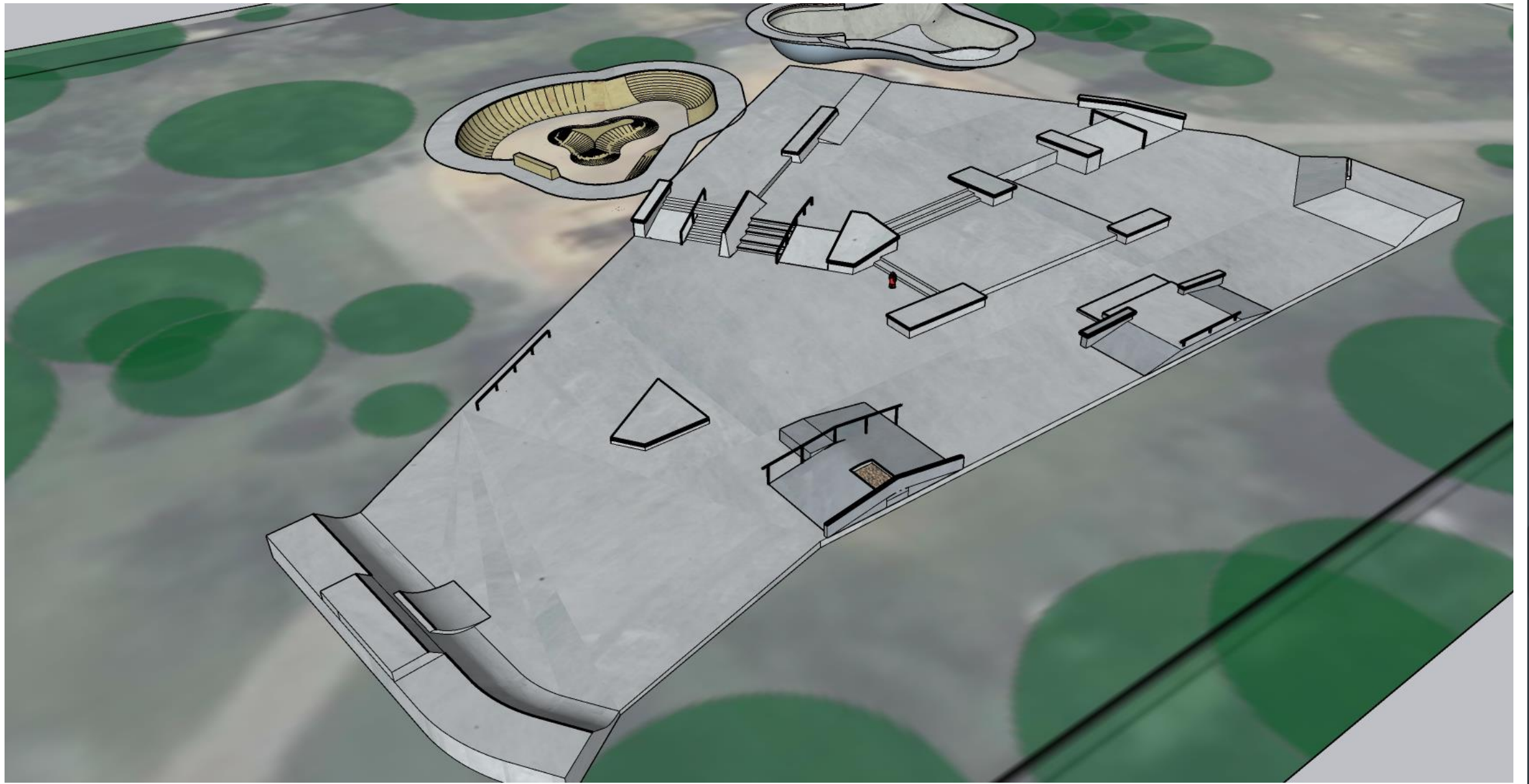

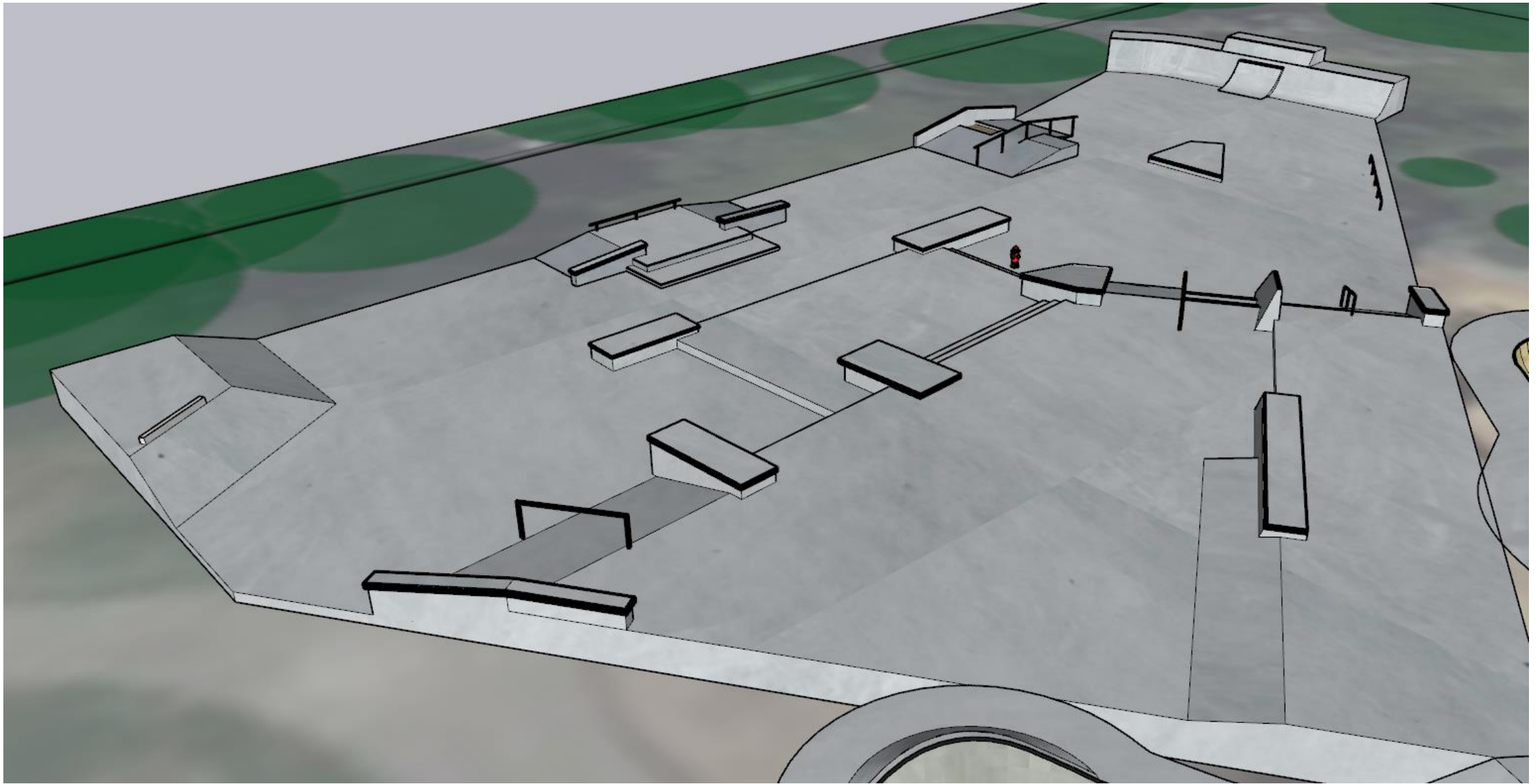

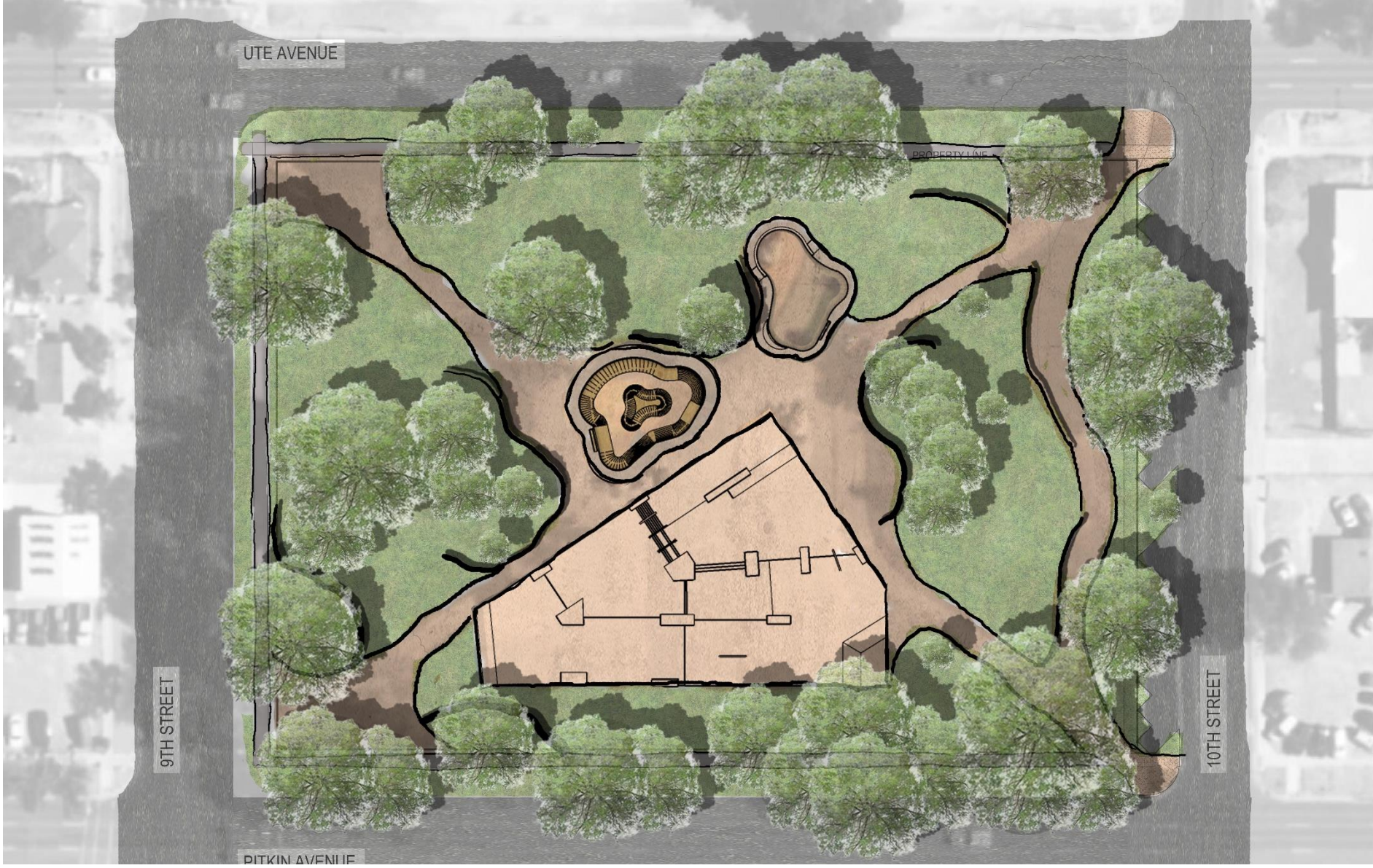

UTE AVENUE

PROPERTY LINE

9TH STREET

10TH STREET

PITKIN AVENUE



Silhouette Bench – Wood Grain Naturals



Cassidy-Plus 45 Gallon Receptacles



Restroom Enclosure



Dog Waste Station



10145 SM OR SMSS W/ OPTIONAL PET FOUNTAIN





-  - Bollard Locations
-  - 3 Pole Location
-  - 4 Pole Location
-  - Possible Tree Removal

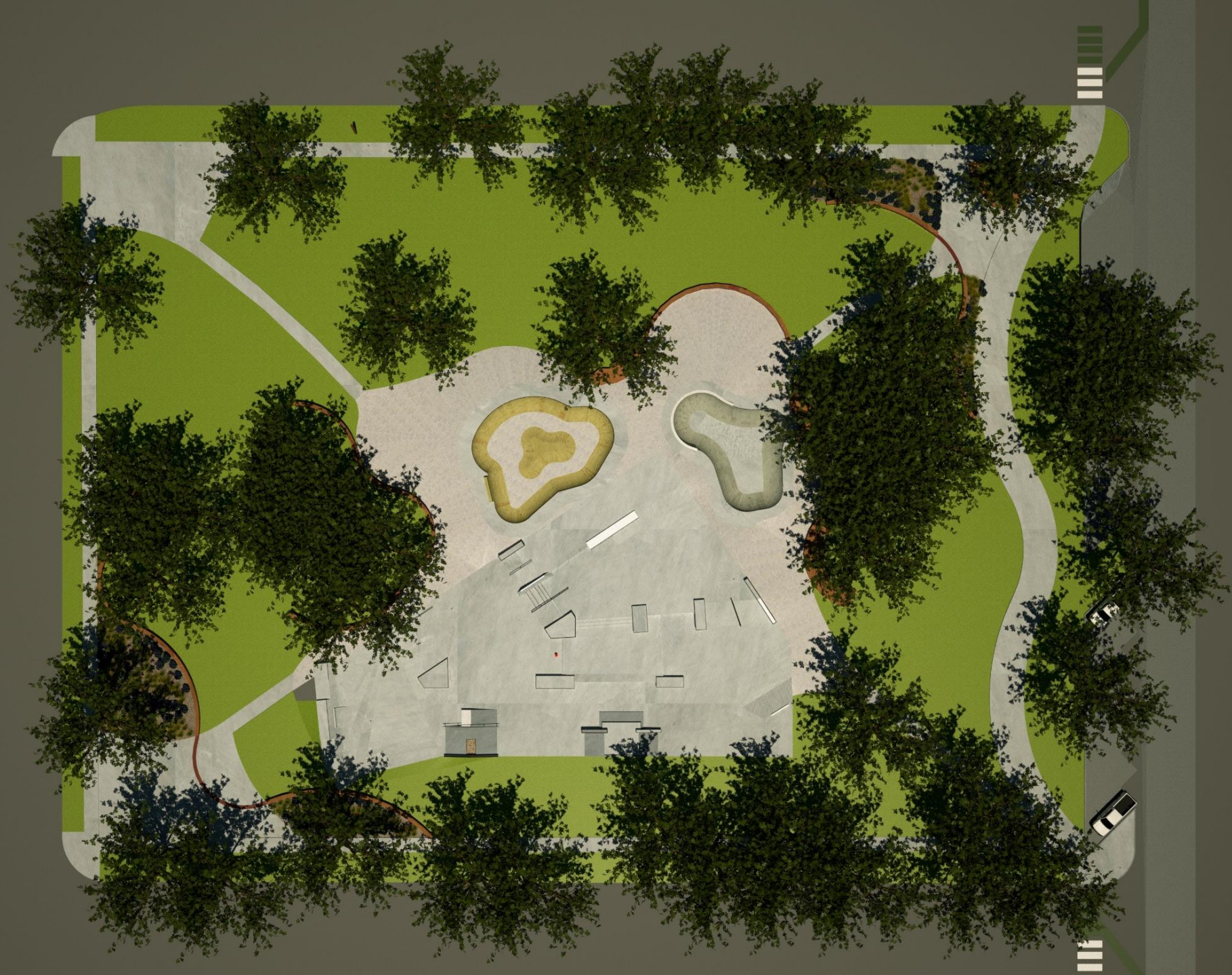

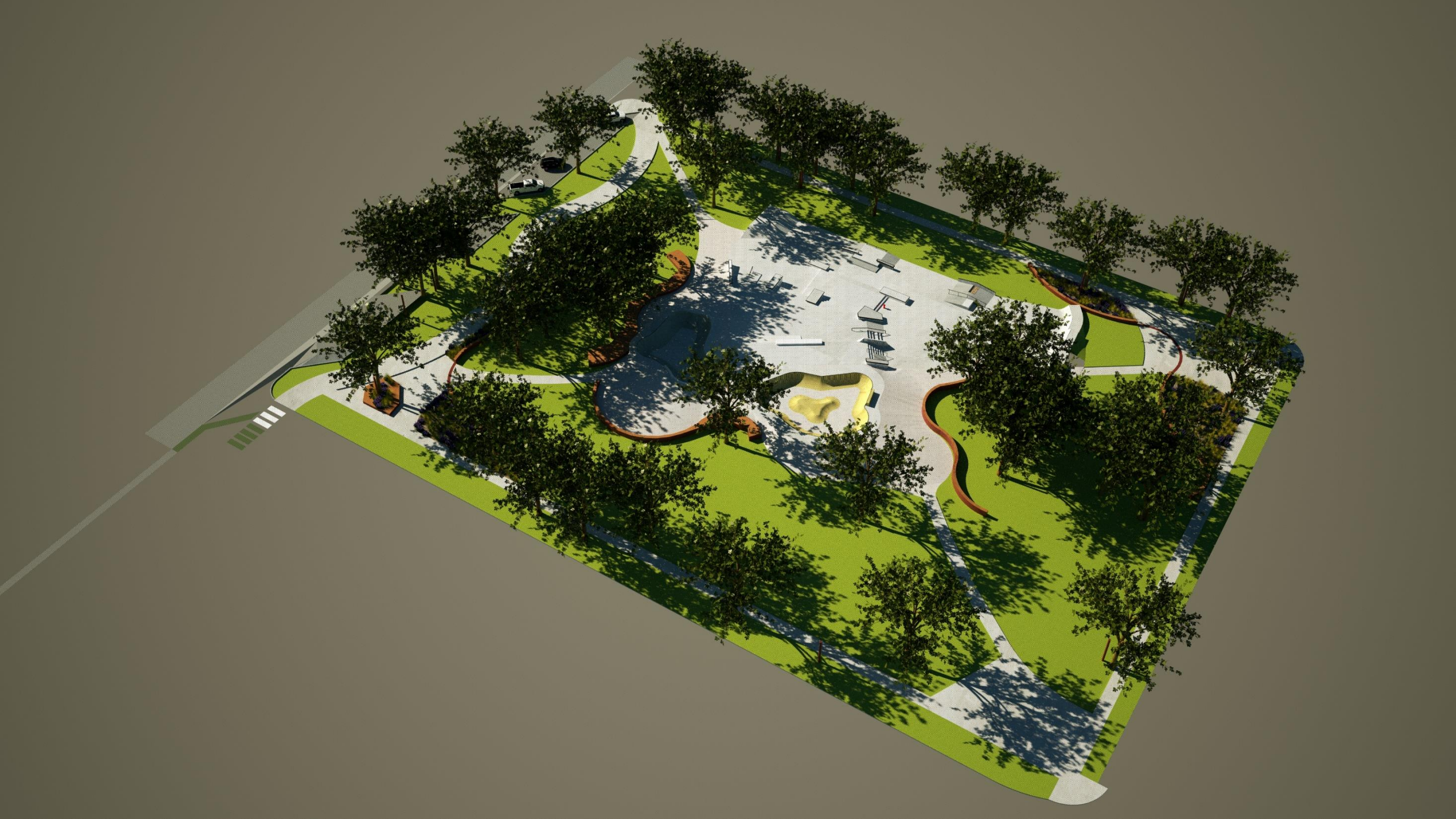

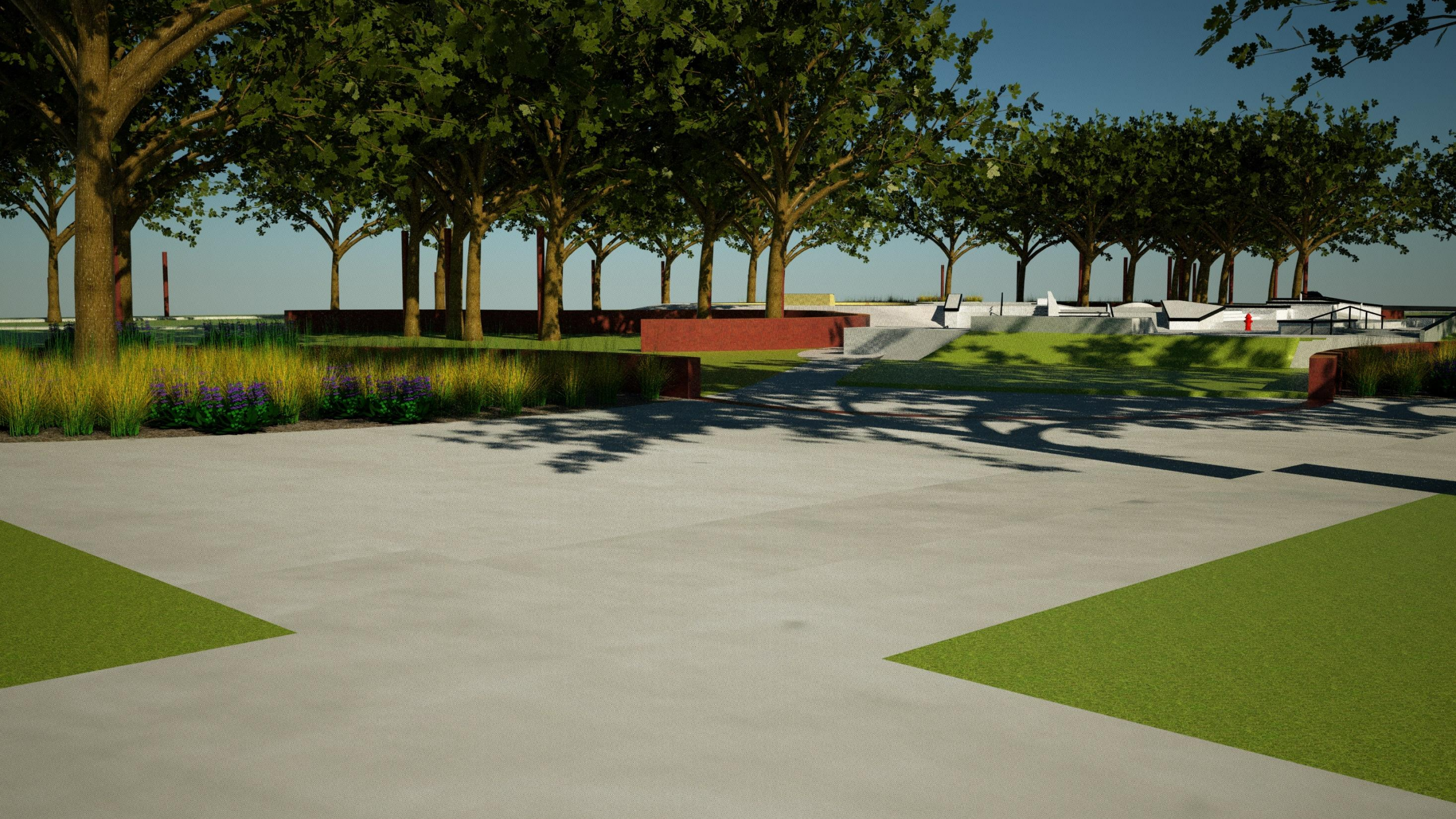



10TH STREET







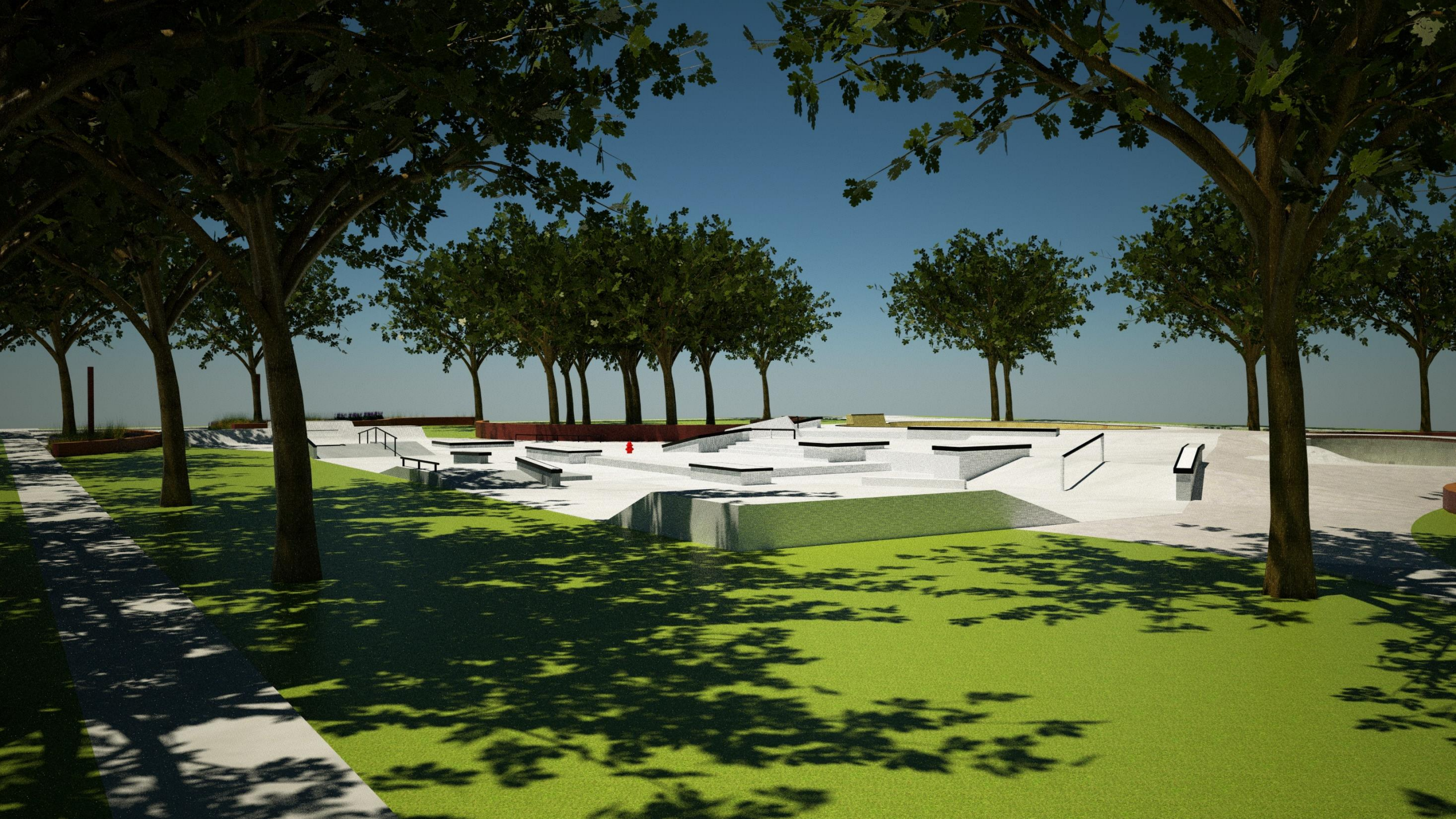

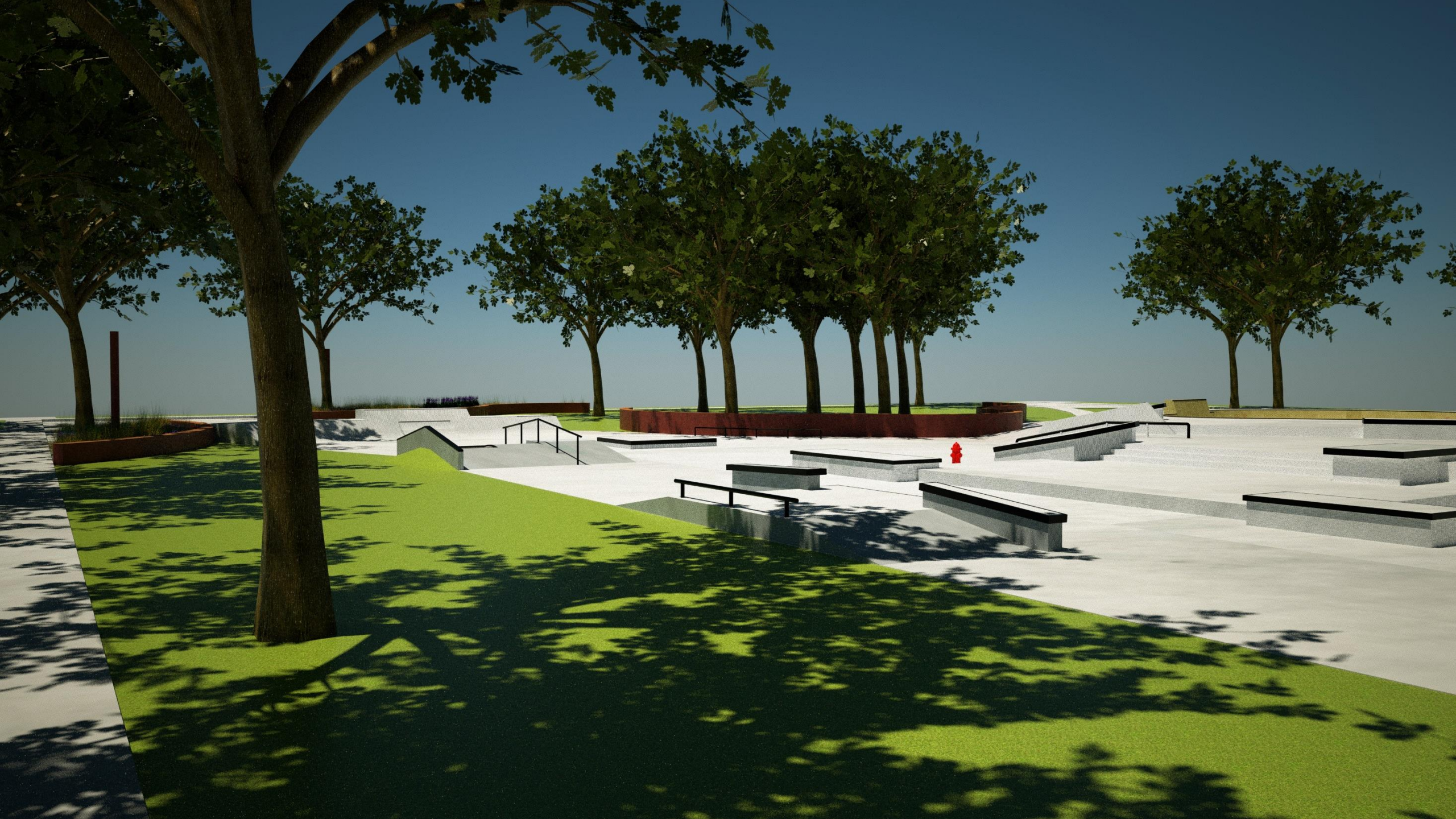







The background features a vibrant, abstract design. On the left side, there is a white, jagged silhouette that resembles a forest or a mountain range. The rest of the background is composed of overlapping, wavy, layered shapes in shades of green and yellow, creating a sense of depth and movement. The text "FLY THROUGH IMAGES" is centered horizontally across the middle of the image.

FLY THROUGH IMAGES

TEAM PAIN

SKATE PARKS

THE MEETING WILL BE AVAILABLE FOR ONE WEEK ON
YOUTUBE STARTING TOMORROW. ANYONE THAT WAS
UNABLE TO ATTEND CAN VIEW THE RECORDING
LINK TO ENGAGE GRAND JUNCTION

<https://engagegj.org/emerson-skate-park>



Thank
YOU



CONCEPTUAL DESIGN
PRESENTATION
FOR
EMERSON PARK
SKATEPARK
CITY COUNCIL MEETING

JULY 31TH, 2023
6 PM Mountain Time



CLAUSON RAWLEY ASSOCIATES INC
landscape architecture. planning. resort design

COLORADO EXPERIENCE



26 SUCCESSFUL CONCRETE SKATEPARKS IN
COLORADO



CLAUSON RAWLEY ASSOCIATES INC
landscape architecture.planning.resort design

JOINED TEAM PAIN FOR THE
ASPEN SKATEPARK - FUTURE PHASE 2 EXPANSION



WORKED WITH TEAM PAIN ON 10 CONCRETE SKATE
PARKS IN COLORADO

TEAM PAIN SKATEPARKS COLORADO STATE SKATEPARK MAP

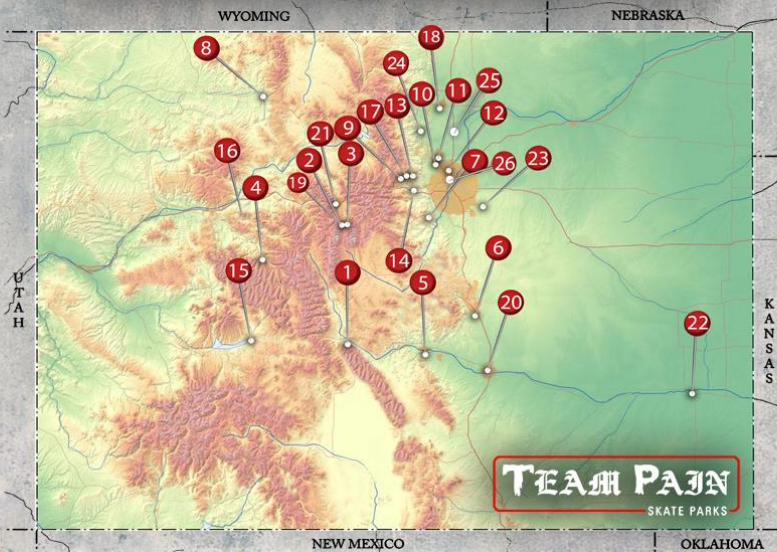



ART



Urban Forester



- The Tree survey was conducted by City of Grand Junction Urban Forester where each tree's species and size were inventoried. The survey included - Species, caliper size, root zone, canopy overhang, health/condition/viability.

COMMUNITY MEETING #1 May 9th



INSTAGRAM – 44K FOLLOWERS
FACEBOOK – 61K FOLLOWERS
YOUTUBE – 2.8M VIEWS



QUESTIONNAIRE'S AVAILABLE FOR LOG IN FROM ANY COMPUTER OR SMART PHONE.



QUESTIONNAIRE RESULTS PROVIDE DIRECT FEEDBACK FROM THE PUBLIC

COMMUNITY MEETING #2 HELD JULY 27TH 2023

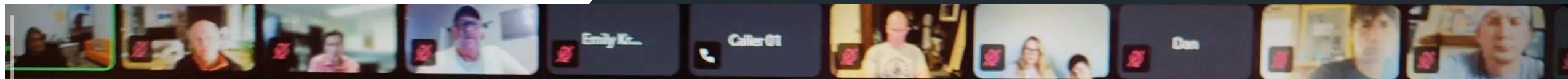

Grand Junction Survey

147

Responses Since
Apr 19

Responses Today
0

Inactive

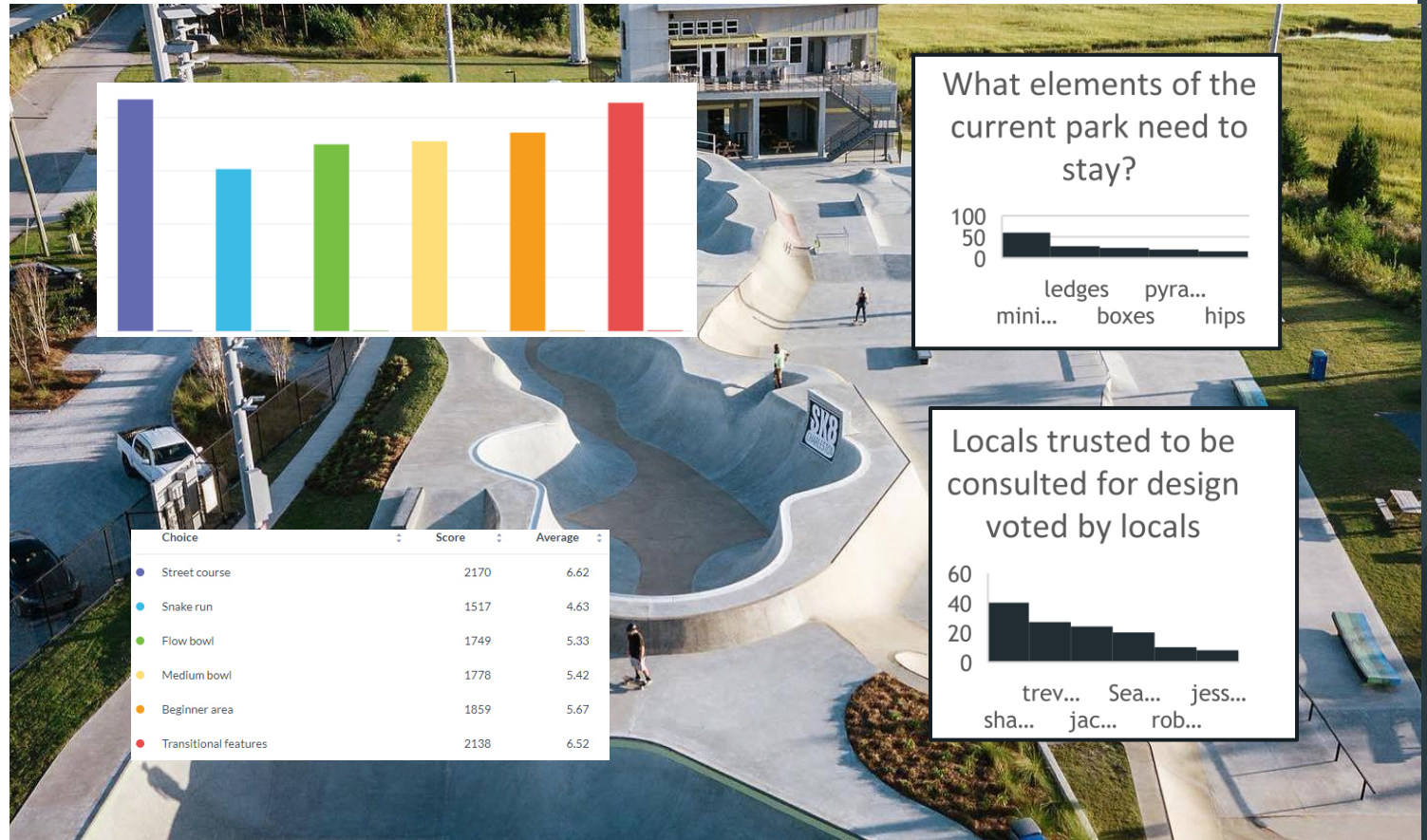



17TH STREET

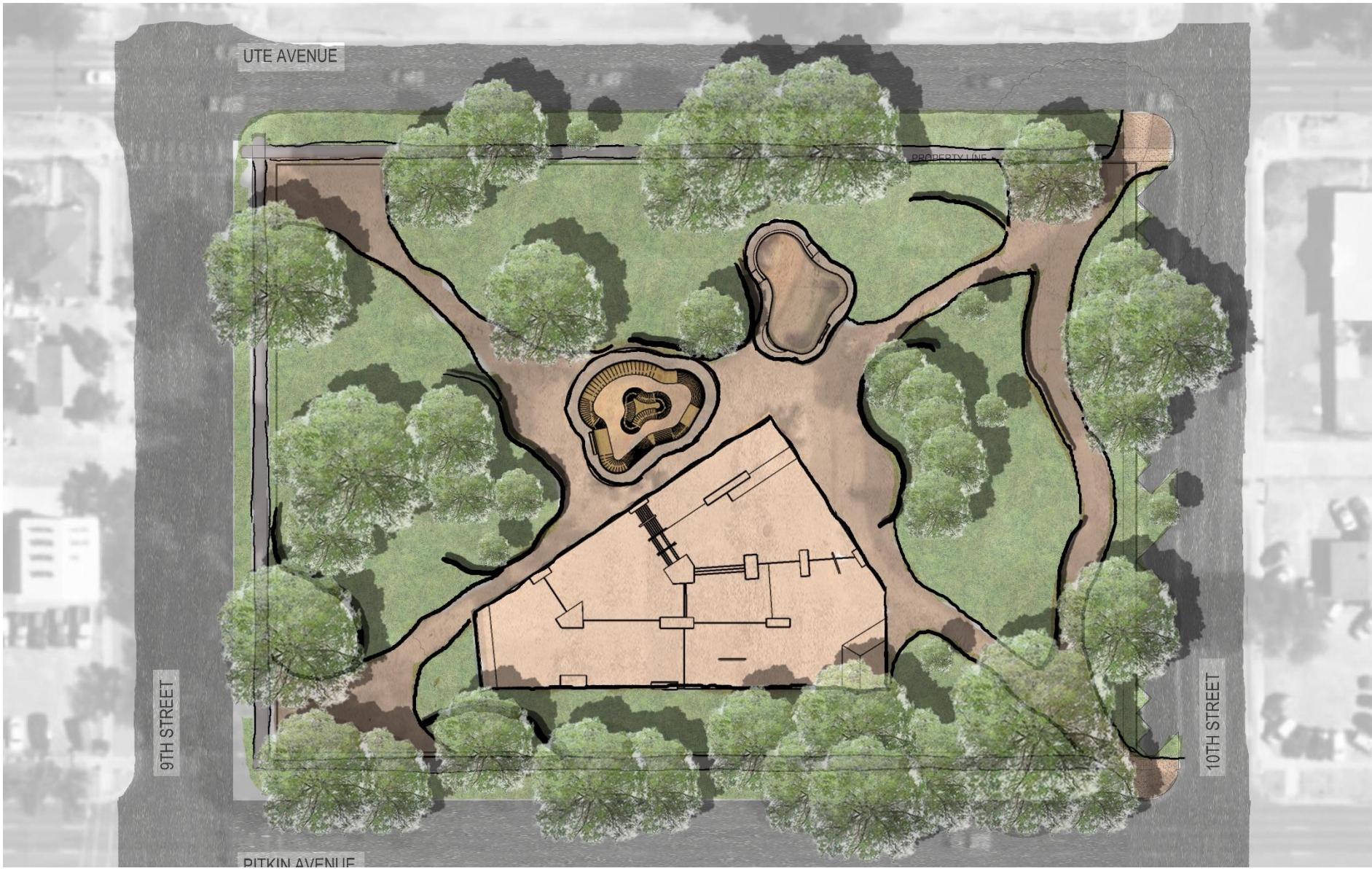

UTE AVENUE

PROPERTY LINE

9TH STREET

10TH STREET

PITKIN AVENUE



-  - Bollard Locations
-  - 3 Pole Location
-  - 4 Pole Location
-  - Possible Tree Removal

**MUSCO DESIGN
DARK SKY COMPLIANT**

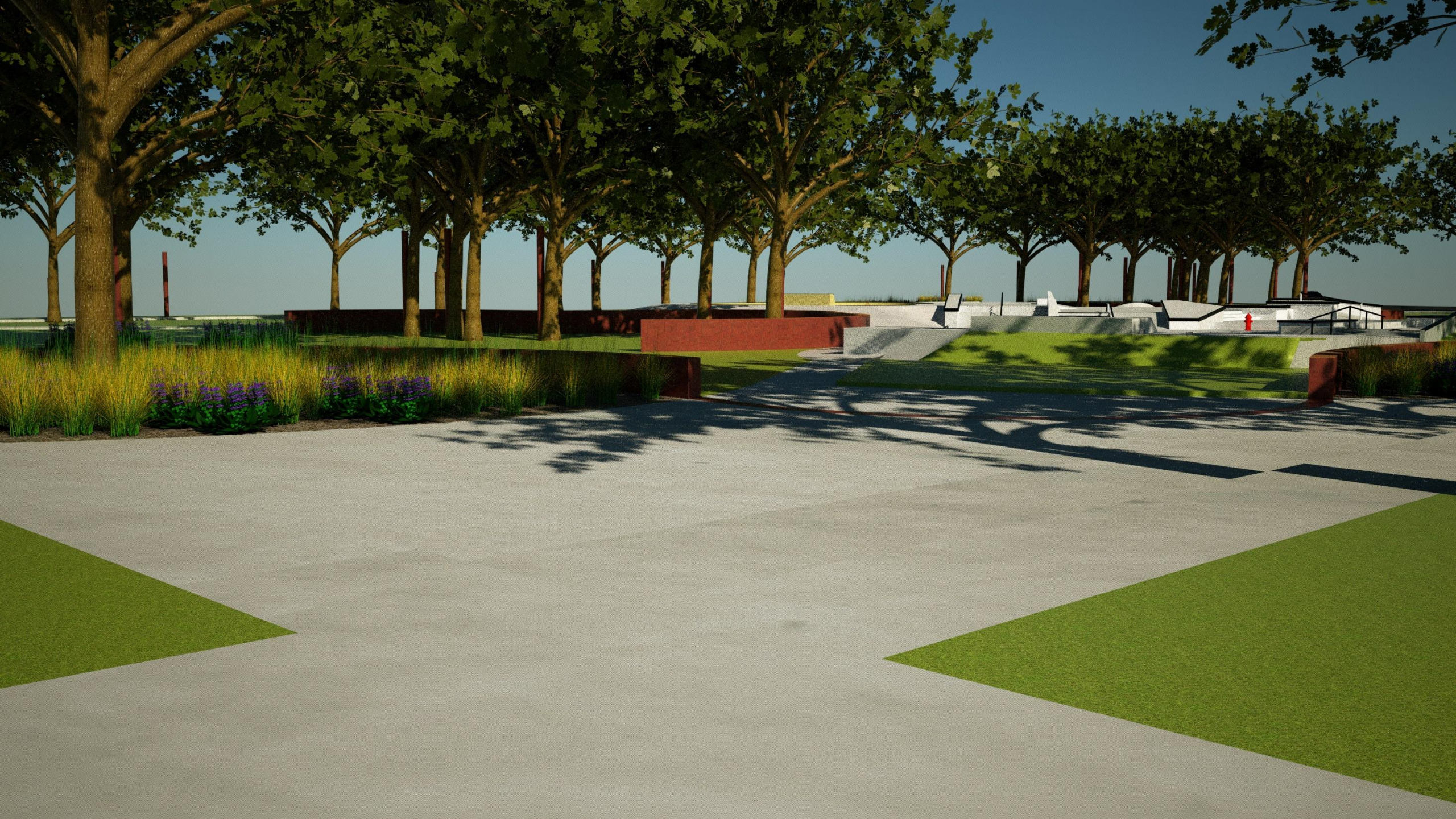





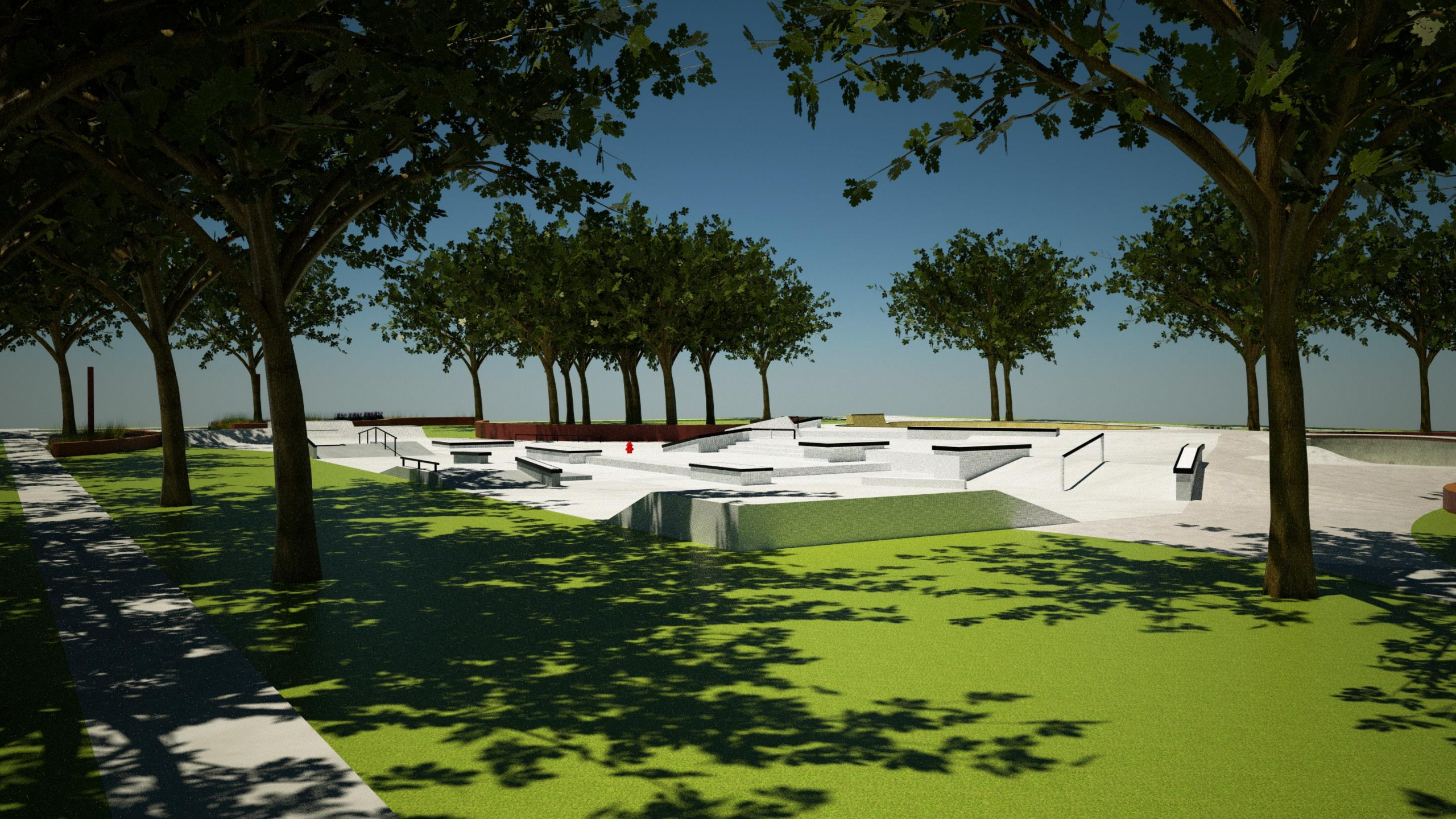



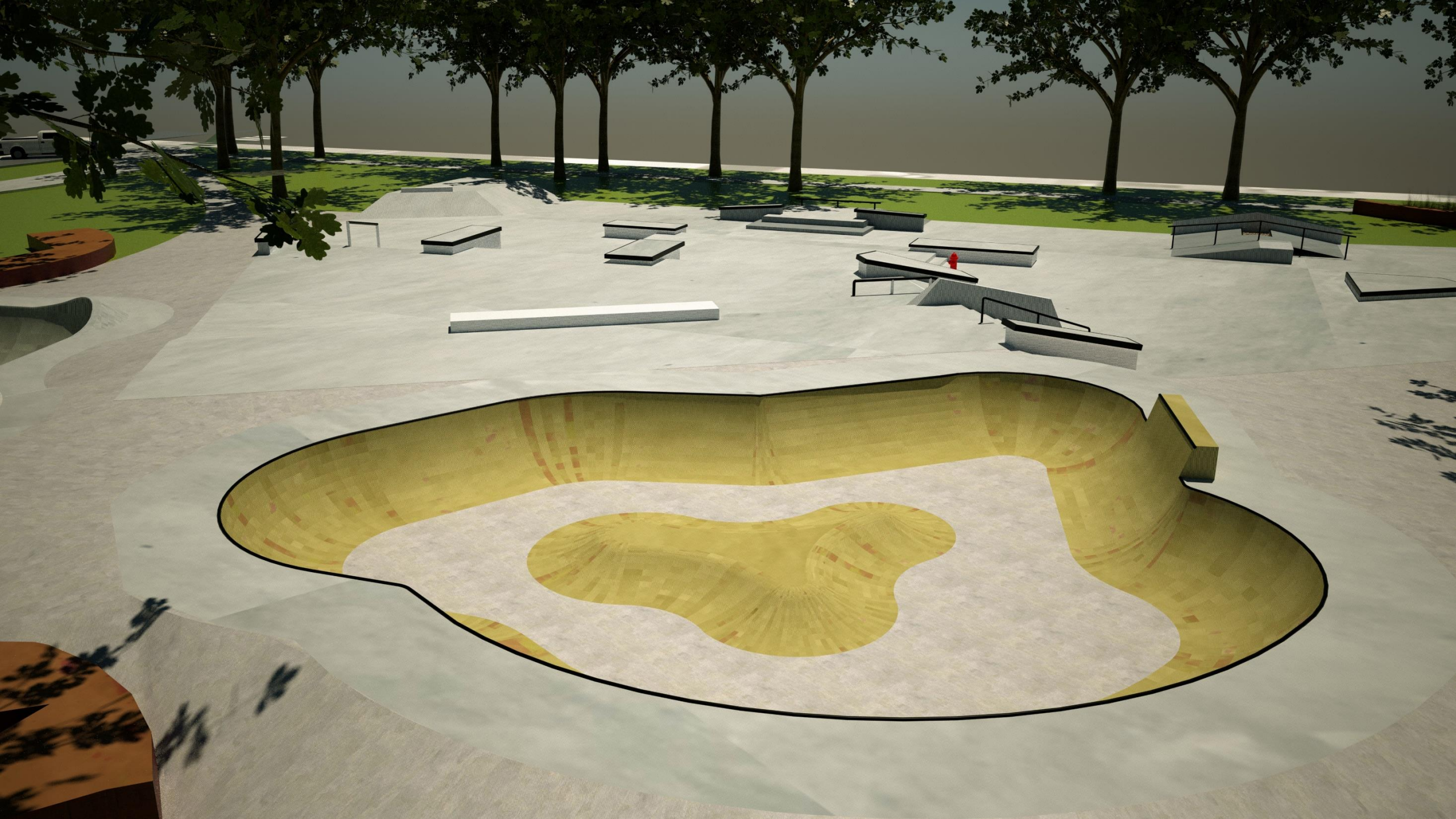

City of Grand Junction Emerson Park

Probable Costs for Wheel Park

Design, Planning, & Construction Documents	\$	174,000
Site Prep	\$	202,000
Skate Park Construction	\$	1,287,000
Amenitites	\$	600,000
Subtotal	\$	2,263,000
	<i>Contengency</i>	\$ 226,300
Anticipated Total	\$	2,489,300

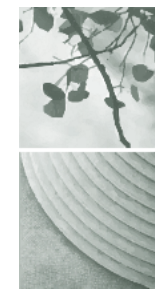

CLAUSON RAWLEY ASSOCIATES INC
landscape architecture.planning.resort design



THANK YOU

Emerson Skate Park

Grand Junction, CO

Lighting System

Pole / Fixture Summary						
Pole ID	Pole Height	Mtg Height	Fixture Qty	Luminaire Type	Load	Circuit
P1, P4	50'	50'	4	TLC-LED-900	3.52 kW	A
P2-P3	50'	50'	3	TLC-LED-900	2.64 kW	A
W1-W8	4'	4'	1	CREE PWY	0.03 kW	B
12			22		12.59 kW	

Circuit Summary			
Circuit	Description	Load	Fixture Qty
A	Skate Park	12.32 kW	14
B	Pathway	0.27 kW	8

Fixture Type Summary							
Type	Source	Wattage	Lumens	L90	L80	L70	Quantity
CREE PWY	LED 5700K - 70 CRI	34W	2,094	--	--	--	8
TLC-LED-900	LED 5700K - 75 CRI	880W	104,000	>120,000	>120,000	>120,000	14

Single Luminaire Amperage Draw Chart								
Driver (.90 min power factor)	Max Line Amperage Per Luminaire							
Single Phase Voltage	208 (60)	220 (60)	240 (60)	277 (60)	347 (60)	380 (60)	480 (60)	
Cree PWY	-	-	-	-	-	-	-	
TLC-LED-900	5.2	4.9	4.5	3.9	3.1	2.9	2.3	

Light Level Summary

Calculation Grid Summary								
Grid Name	Calculation Metric	Illumination					Circuits	Fixture Qty
		Ave	Min	Max	Max/Min	Ave/Min		
150' Off-Set Spill	Horizontal Illuminance	0	0	0	0.00		A	14
150' Off-Set Spill	Max Candela Metric	36.3	0	389	0.00		A	14
150' Off-Set Spill	Max Vertical Illuminance Metric	0	0	0.01	0.00		A	14
Pathway	Horizontal Illuminance	0.13	0	24	0.00		B	8
Skate Park	Horizontal Illuminance	32.6	21	47	2.20	1.55	A	14

From Hometown to Professional

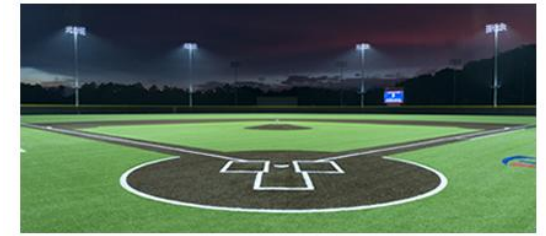

We Make It Happen.

Not to be reproduced in whole or part without the written consent of Musco Sports Lighting, LLC. ©1981, 2023 Musco Sports Lighting, LLC.

EQUIPMENT LIST FOR AREAS SHOWN

Pole		Luminaires							
QTY	LOCATION	SIZE	GRADE ELEVATION	MOUNTING HEIGHT	LUMINAIRE TYPE	QTY / POLE	THIS GRID	OTHER GRIDS	
2	P1, P4	50'	-	50'	TLC-LED-900	4	4	0	
2	P2-P3	50'	-	50'	TLC-LED-900	3	3	0	
4	TOTALS						14	14	0

Emerson Skate Park
Grand Junction, CO

GRID SUMMARY	
Name:	Skate Park
Size:	220' x 215'
Spacing:	20.0' x 20.0'
Height:	3.0' above grade

ILLUMINATION SUMMARY	
MAINTAINED HORIZONTAL FOOTCANDLES	
Entire Grid	
Guaranteed Average:	30
Scan Average:	32.62
Maximum:	47
Minimum:	21
Avg / Min:	1.53
Guaranteed Max / Min:	3
Max / Min:	2.20
UG (adjacent pts):	1.66
CU:	0.77
No. of Points:	81
LUMINAIRE INFORMATION	
Applied Circuits:	A
No. of Luminaires:	14
Total Load:	12.32 kW

Guaranteed Performance: The ILLUMINATION described above is guaranteed per your Musco Warranty document and includes a 0.95 dirt depreciation factor.

Field Measurements: Individual field measurements may vary from computer-calculated predictions and should be taken in accordance with IESNA RP-6-15.

Electrical System Requirements: Refer to Amperage Draw Chart and/or the "Musco Control System Summary" for electrical sizing.

Installation Requirements: Results assume ± 3% nominal voltage at line side of the driver and structures located within 3 feet (1m) of design locations.

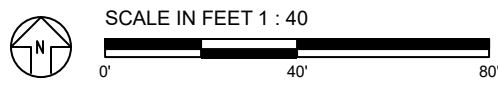
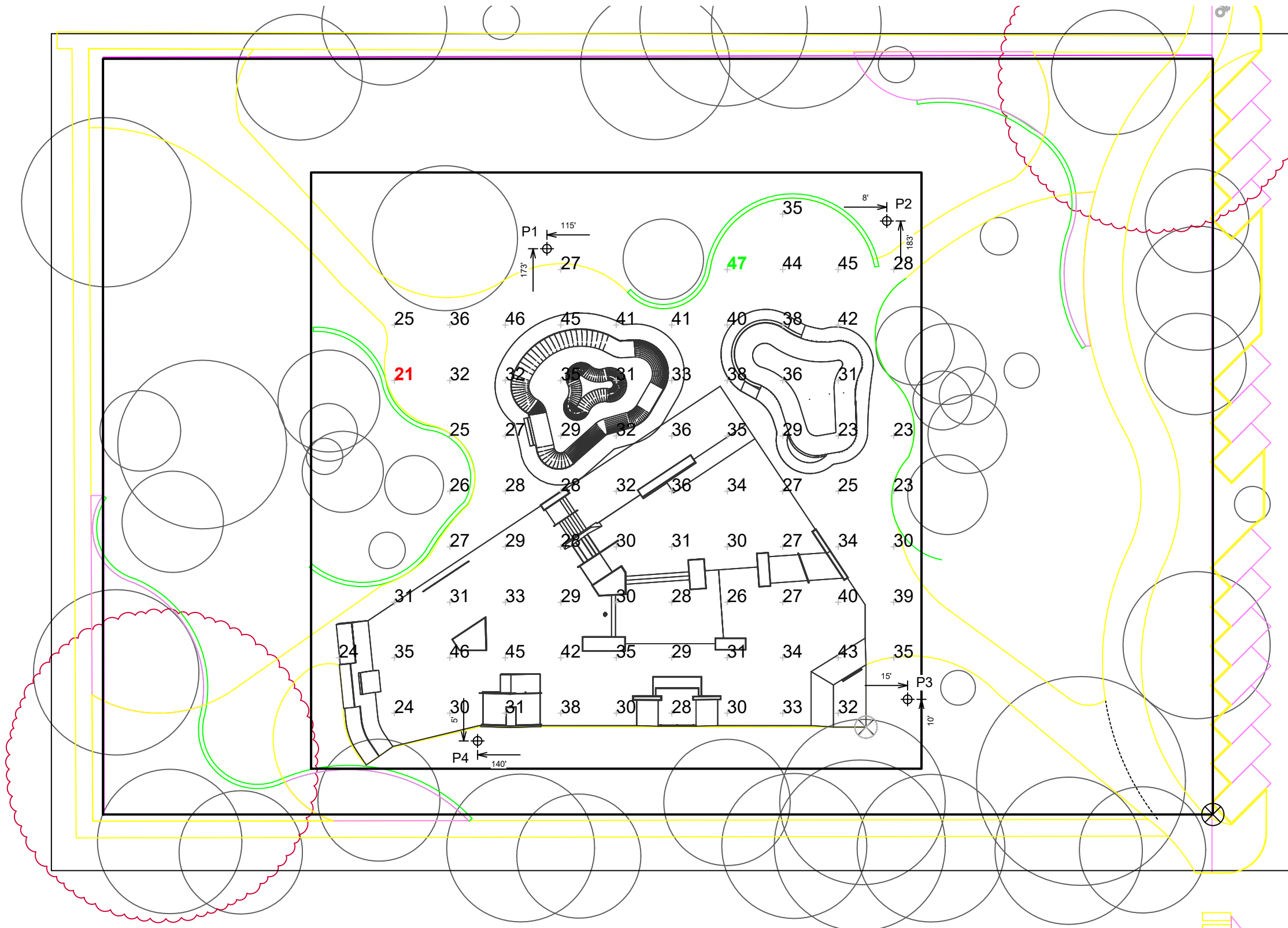

Pole location(s) Ⓢ dimensions are relative to 0,0 reference point(s) ⊗

ENGINEERED DESIGN By: C.Hensley · File #228138A · 28-Jul-23



Not to be reproduced in whole or part without the written consent of Musco Sports Lighting, LLC. ©1981, 2023 Musco Sports Lighting, LLC.

ILLUMINATION SUMMARY

EQUIPMENT LIST FOR AREAS SHOWN

Pole		Luminaires						
QTY	LOCATION	SIZE	GRADE ELEVATION	MOUNTING HEIGHT	LUMINAIRE TYPE	QTY / POLE	THIS GRID	OTHER GRIDS
8	W1-W8	3.5'	-	3.5'	CREE PWY	1	1	0
8	TOTALS							
						8	8	0

Emerson Skate Park
Grand Junction, CO

GRID SUMMARY	
Name:	Pathway
Size:	400' x 273'
Spacing:	10.0' x 10.0'
Height:	0.0' above grade

ILLUMINATION SUMMARY	
MAINTAINED HORIZONTAL FOOTCANDLES	
Entire Grid	
Scan Average:	0.13
Maximum:	24
Minimum:	0
Avg / Min:	-
Max / Min:	-
UG (adjacent pts):	1150.07
CU:	0.75
No. of Points:	1080
LUMINAIRE INFORMATION	
Applied Circuits:	B
No. of Luminaires:	8
Total Load:	0.27 kW

Guaranteed Performance: The ILLUMINATION described above is guaranteed per your Musco Warranty document and includes a 0.95 dirt depreciation factor.

Field Measurements: Individual field measurements may vary from computer-calculated predictions and should be taken in accordance with IESNA RP-6-15.

Electrical System Requirements: Refer to Amperage Draw Chart and/or the "Musco Control System Summary" for electrical sizing.

Installation Requirements: Results assume ± 3% nominal voltage at line side of the driver and structures located within 3 feet (1m) of design locations.

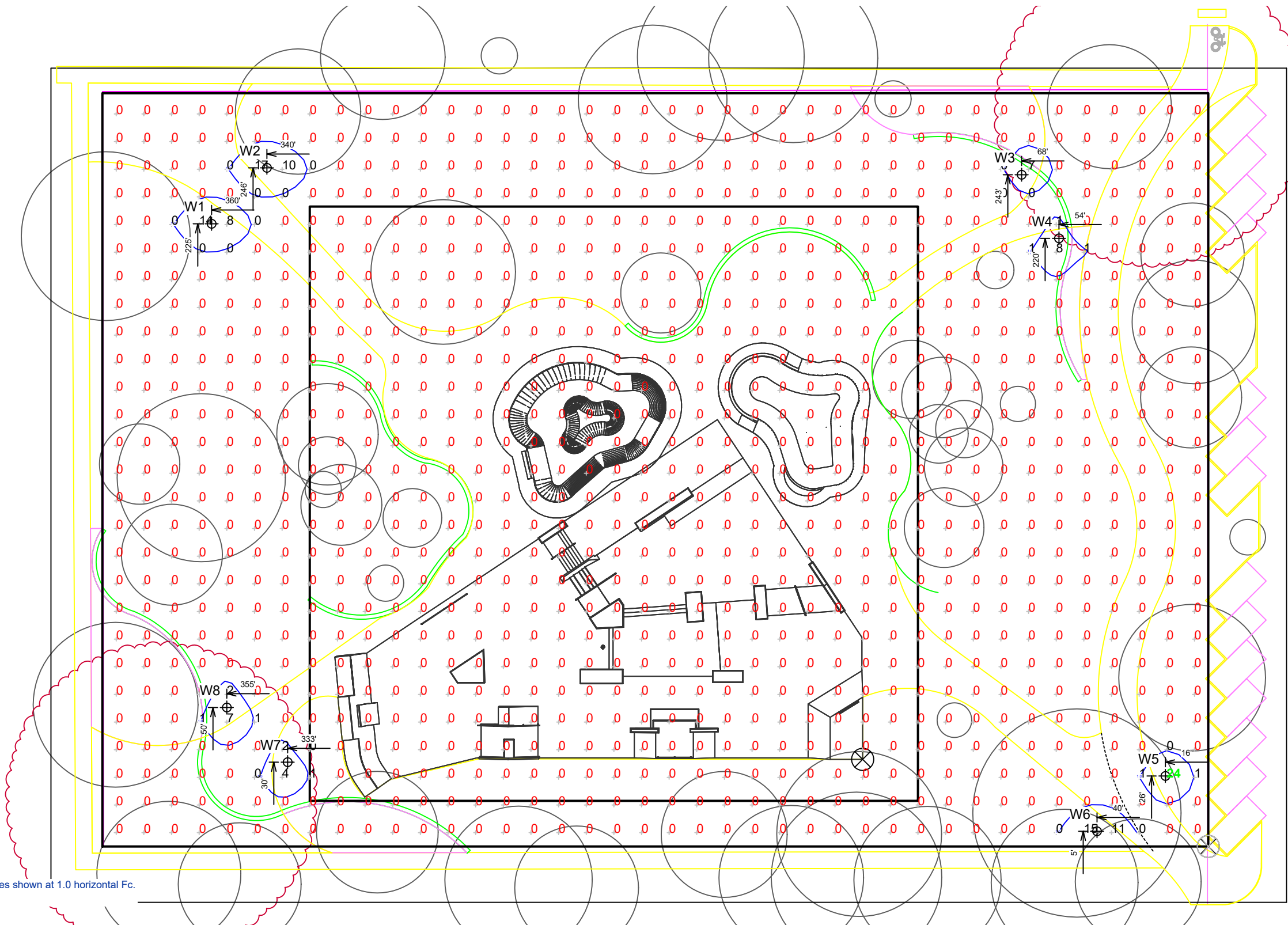

NOTES: Contour lines shown at 1.0 horizontal Fc.

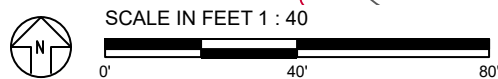

Pole location(s) ⊕ dimensions are relative to 0,0 reference point(s) ⊗



We Make It Happen.

Not to be reproduced in whole or part without the written consent of Musco Sports Lighting, LLC. ©1981, 2023 Musco Sports Lighting, LLC.

EQUIPMENT LIST FOR AREAS SHOWN								
Pole				Luminaires				
QTY	LOCATION	SIZE	GRADE ELEVATION	MOUNTING HEIGHT	LUMINAIRE TYPE	QTY / POLE	THIS GRID	OTHER GRIDS
2	P1, P4	50'	-	50'	TLC-LED-900	4	4	0
2	P2-P3	50'	-	50'	TLC-LED-900	3	3	0
4	TOTALS					14	14	0

Emerson Skate Park

Grand Junction, CO

GRID SUMMARY	
Name:	150' Off-Set Spill
Spacing:	30.0'
Height:	3.0' above grade

ILLUMINATION SUMMARY	
HORIZONTAL FOOTCANDLES	
Entire Grid	
Scan Average:	0.0001
Maximum:	0.00
Minimum:	0.00
No. of Points:	61
LUMINAIRE INFORMATION	
Applied Circuits:	A
No. of Luminaires:	14
Total Load:	12.32 kW

Guaranteed Performance: The ILLUMINATION described above is guaranteed per your Musco Warranty document.

Field Measurements: Individual field measurements may vary from computer-calculated predictions and should be taken in accordance with IESNA RP-6-15.

Electrical System Requirements: Refer to Amperage Draw Chart and/or the "Musco Control System Summary" for electrical sizing.

Installation Requirements: Results assume ± 3% nominal voltage at line side of the driver and structures located within 3 feet (1m) of design locations.

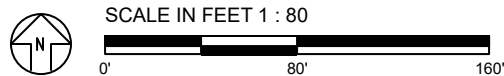
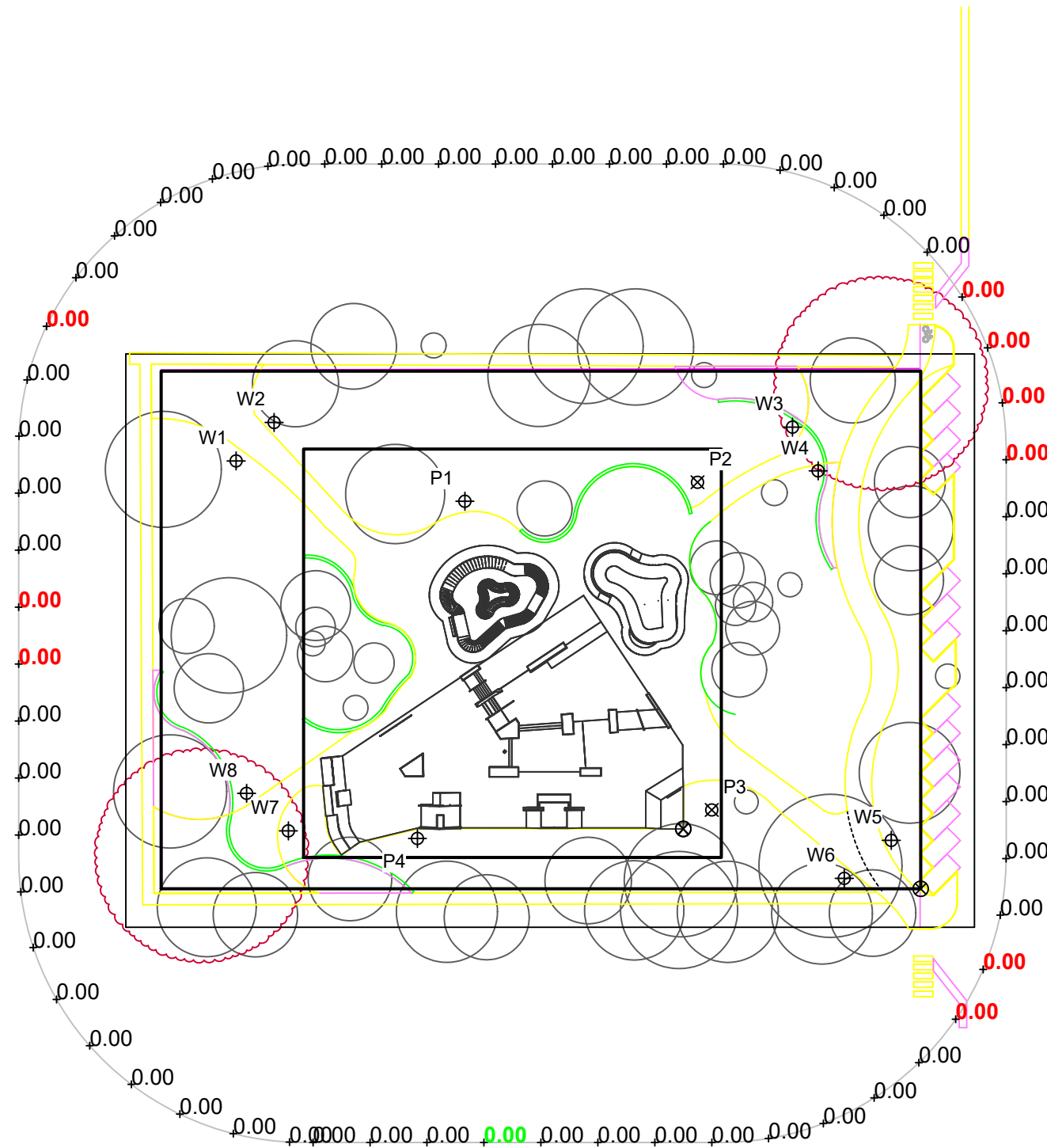

ENGINEERED DESIGN By: C.Hensley · File #228138A · 28-Jul-23

Pole location(s) ⊕ dimensions are relative to 0,0 reference point(s) ⊗



We Make It Happen.

Not to be reproduced in whole or part without the written consent of Musco Sports Lighting, LLC. ©1981, 2023 Musco Sports Lighting, LLC.

ILLUMINATION SUMMARY

EQUIPMENT LIST FOR AREAS SHOWN								
Pole				Luminaires				
QTY	LOCATION	SIZE	GRADE ELEVATION	MOUNTING HEIGHT	LUMINAIRE TYPE	QTY / POLE	THIS GRID	OTHER GRIDS
2	P1, P4	50'	-	50'	TLC-LED-900	4	4	0
2	P2-P3	50'	-	50'	TLC-LED-900	3	3	0
4	TOTALS					14	14	0

Emerson Skate Park

Grand Junction, CO

GRID SUMMARY	
Name:	150' Off-Set Spill
Spacing:	30.0'
Height:	3.0' above grade

ILLUMINATION SUMMARY	
MAX VERTICAL FOOTCANDLES	
Entire Grid	
Scan Average:	0.0004
Maximum:	0.01
Minimum:	0.00
No. of Points:	61
LUMINAIRE INFORMATION	
Applied Circuits:	A
No. of Luminaires:	14
Total Load:	12.32 kW

Guaranteed Performance: The ILLUMINATION described above is guaranteed per your Musco Warranty document.

Field Measurements: Individual field measurements may vary from computer-calculated predictions and should be taken in accordance with IESNA RP-6-15.

Electrical System Requirements: Refer to Amperage Draw Chart and/or the "Musco Control System Summary" for electrical sizing.

Installation Requirements: Results assume ± 3% nominal voltage at line side of the driver and structures located within 3 feet (1m) of design locations.

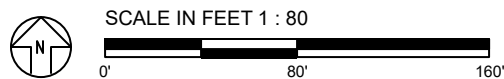
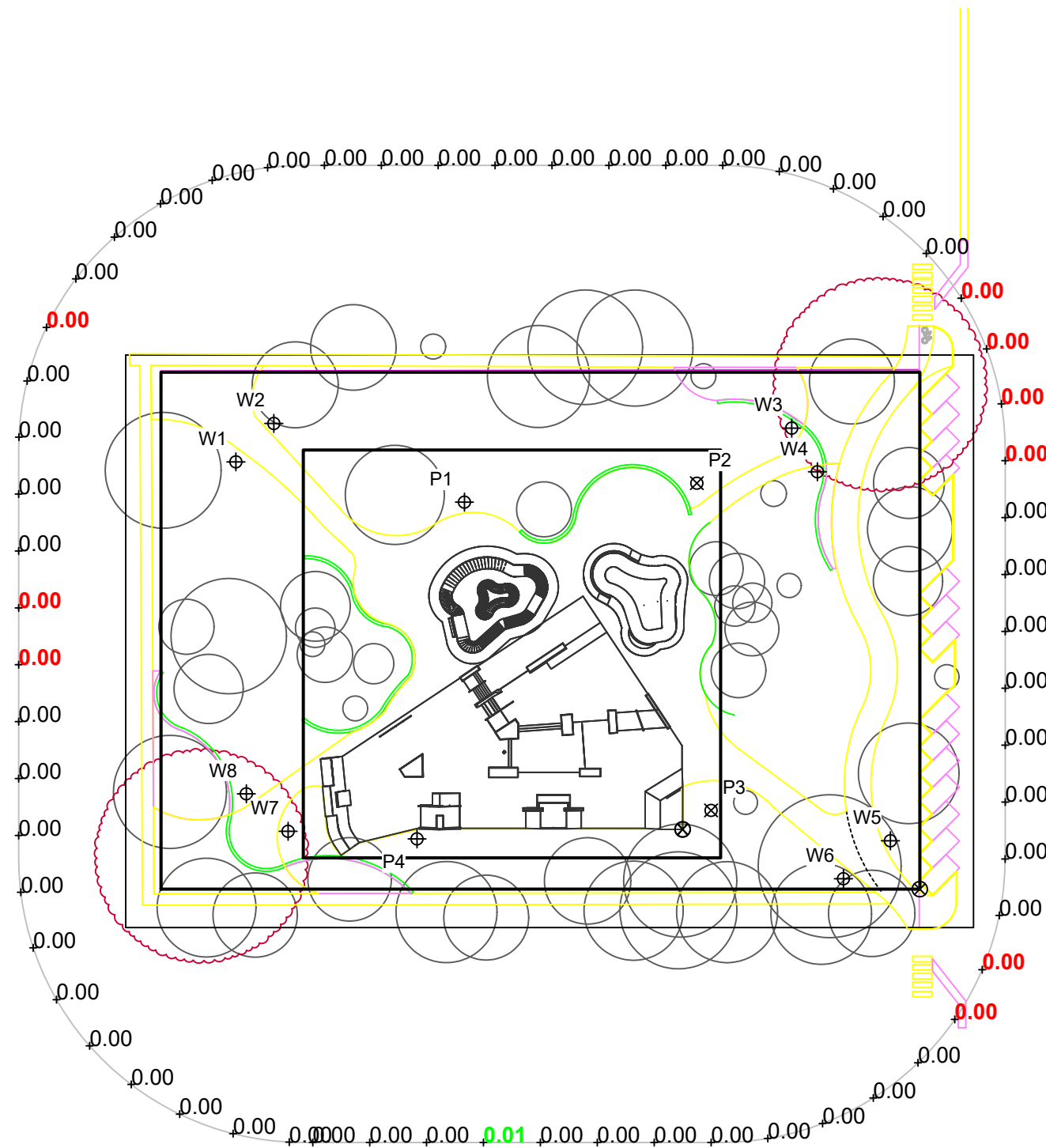

ENGINEERED DESIGN By: C.Hensley · File #228138A · 28-Jul-23

Pole location(s) ⊕ dimensions are relative to 0,0 reference point(s) ⊗



We Make It Happen.

Not to be reproduced in whole or part without the written consent of Musco Sports Lighting, LLC. ©1981, 2023 Musco Sports Lighting, LLC.

ILLUMINATION SUMMARY

EQUIPMENT LIST FOR AREAS SHOWN								
Pole				Luminaires				
QTY	LOCATION	SIZE	GRADE ELEVATION	MOUNTING HEIGHT	LUMINAIRE TYPE	QTY / POLE	THIS GRID	OTHER GRIDS
2	P1, P4	50'	-	50'	TLC-LED-900	4	4	0
2	P2-P3	50'	-	50'	TLC-LED-900	3	3	0
4	TOTALS					14	14	0

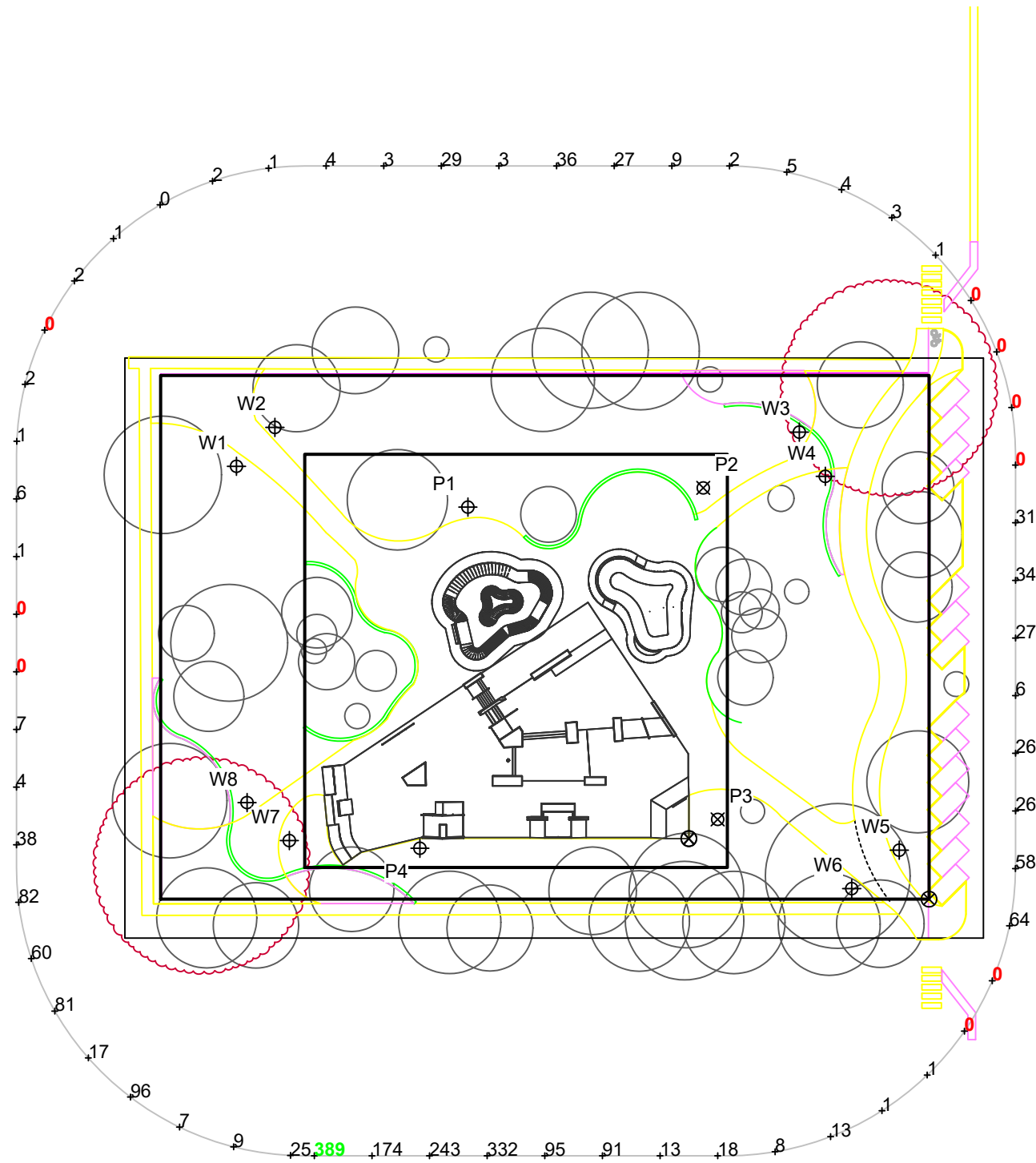

Emerson Skate Park

Grand Junction, CO

GRID SUMMARY	
Name:	150' Off-Set Spill
Spacing:	30.0'
Height:	3.0' above grade

ILLUMINATION SUMMARY	
CANDELA (PER FIXTURE)	
Scan Average:	Entire Grid 36.3383
Maximum:	388.85
Minimum:	0.00
No. of Points:	61
LUMINAIRE INFORMATION	
Applied Circuits:	A
No. of Luminaires:	14
Total Load:	12.32 kW

Guaranteed Performance: The ILLUMINATION described above is guaranteed per your Musco Warranty document.

Field Measurements: Individual field measurements may vary from computer-calculated predictions and should be taken in accordance with IESNA RP-6-15.

Electrical System Requirements: Refer to Amperage Draw Chart and/or the "Musco Control System Summary" for electrical sizing.

Installation Requirements: Results assume ± 3% nominal voltage at line side of the driver and structures located within 3 feet (1m) of design locations.

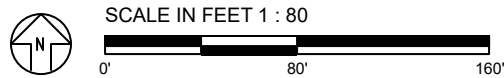

ENGINEERED DESIGN By: C.Hensley · File #228138A · 28-Jul-23

Pole location(s) ⊕ dimensions are relative to 0,0 reference point(s) ⊗



We Make It Happen.

Not to be reproduced in whole or part without the written consent of Musco Sports Lighting, LLC. ©1981, 2023 Musco Sports Lighting, LLC.

ILLUMINATION SUMMARY

Emerson Skate Park

Grand Junction, CO

EQUIPMENT LAYOUT

INCLUDES:

- Pathway
- Skate Park

Electrical System Requirements: Refer to Amperage Draw Chart and/or the "Musco Control System Summary" for electrical sizing.

Installation Requirements: Results assume ± 3% nominal voltage at line side of the driver and structures located within 3 feet (1m) of design locations.

EQUIPMENT LIST FOR AREAS SHOWN

QTY	LOCATION	Pole		Luminaires		QTY / POLE
		SIZE	GRADE ELEVATION	MOUNTING HEIGHT	LUMINAIRE TYPE	
2	P1, P4	50'	-	50'	TLC-LED-900	4
2	P2-P3	50'	-	50'	TLC-LED-900	3
8	W1-W8	3.5'	-	3.5'	CREE PWY	1
12	TOTALS					22

SINGLE LUMINAIRE AMPERAGE DRAW CHART

Driver (.90 min power factor)	Line Amperage Per Luminaire (max draw)						
	208 (60)	220 (60)	240 (60)	277 (60)	347 (60)	380 (60)	480 (60)
Cree PWY	-	-	-	-	-	-	-
TLC-LED-900	5.2	4.9	4.5	3.9	3.1	2.9	2.3

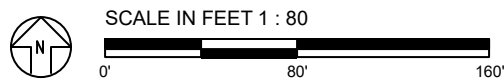
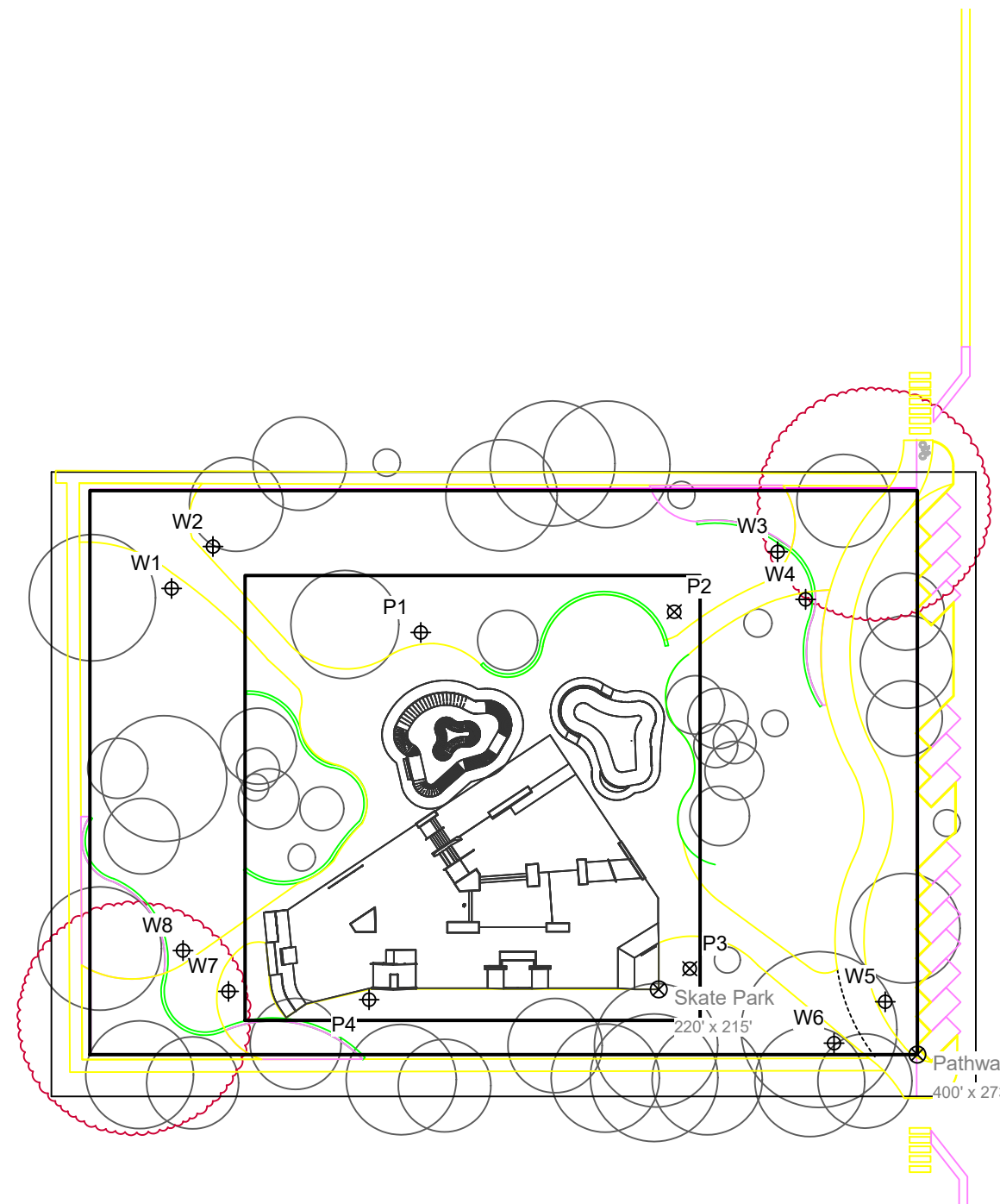

ENGINEERED DESIGN By: C.Hensley · File #228138A · 28-Jul-23

Pole location(s) ⊕ dimensions are relative to 0,0 reference point(s) ⊗



We Make It Happen.

Not to be reproduced in whole or part without the written consent of Musco Sports Lighting, LLC. ©1981, 2023 Musco Sports Lighting, LLC.

IMPORTANT SAFEGUARDS

When using electrical equipment, basic safety precautions should always be followed including the following:

READ AND FOLLOW ALL SAFETY INSTRUCTIONS

1. To avoid the possibility of electrical shock, turn off power supply before installation or servicing. Installation and servicing should be performed by qualified personnel.
2. Product must be installed in accordance with NEC or your local electrical code. If you are not familiar with these codes and requirements, consult a qualified electrician.
3. This carton contains light fixture only. Anchor bolts and mounting template shipped separately

SAVE THESE INSTRUCTIONS FOR FUTURE REFERENCE

TO INSTALL:

INSTALLATION INSTRUCTIONS

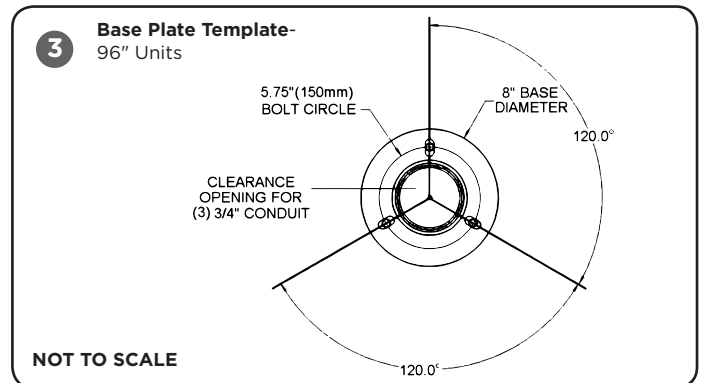
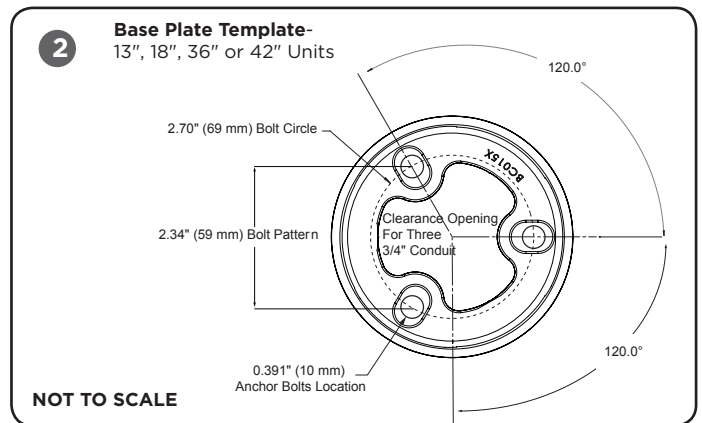
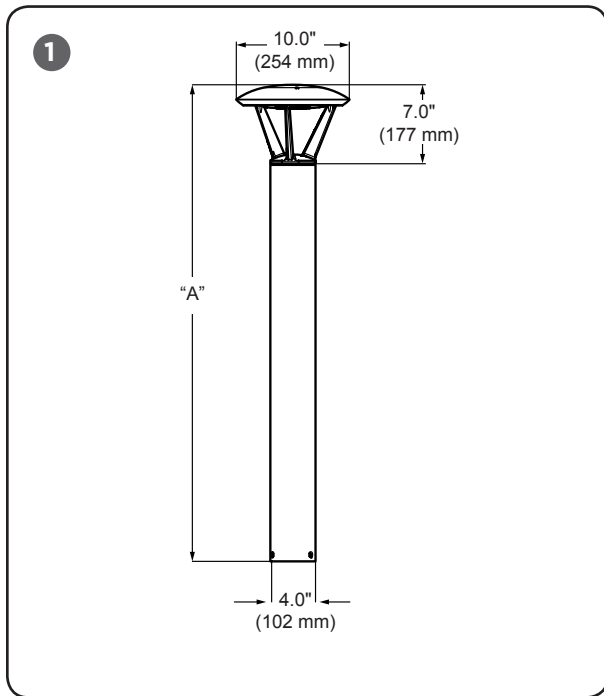
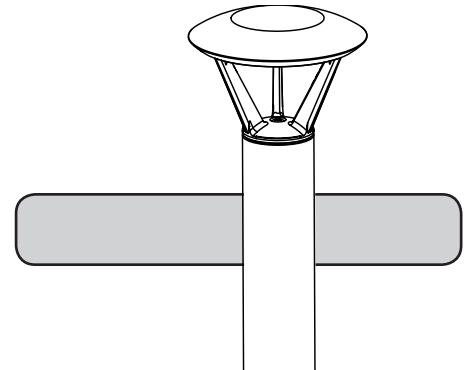

FOUNDATION

MODEL	DIM. "A"	BASE PLATE
Landscape - 12	13"	SEE FIGURE 2
Landscape - 18	18"	
Pathway	36"	
Pathway	42"	
Pedestrian	96"	SEE FIGURE 3

STEP 1:

Foundation should be a minimum of 12 inches in diameter, finished, level and smooth, with a depth below grade of 24 inches.

NOTE: In areas where frost is imminent, consult a civil engineer for a recommended foundation detail.

STEP 2:

Depending in the height of the luminaire, there are two different base plates that are used. See **Figure 1** and the Table on the left to determine the base type. Review **Figure 2 and 3** verify base type.

IMPORTANT: Verify the base plate type before preparing the foundation.

STEP 3:

Provided are (3) 3/8 - 6" anchor bolts and mounting template (shipped separately). Use template to set anchor bolts at proper location (Note conduit entry allowance). Anchor bolts should project 2 inches above concrete.

NOTE: Bolt slots in fixture base allow for anchor bolt circle range of 2.84" (72 mm) maximum diameter to 2.45" (62 mm) minimum diameter. **HOWEVER,** conduit must always be directly centered within anchor bolts.

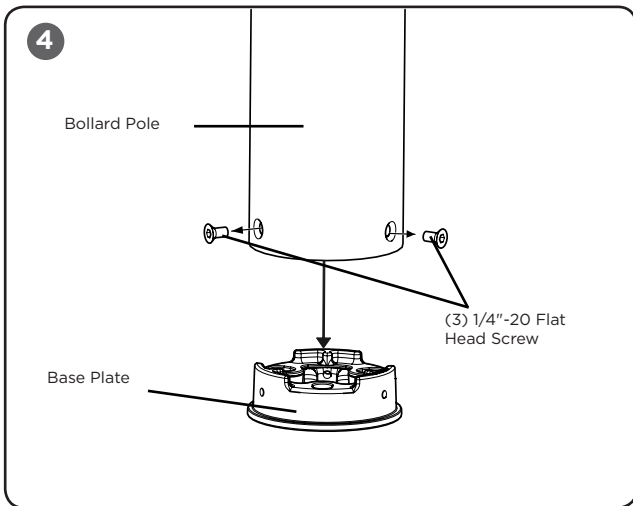

INSTALLATION FOR 13", 18", 36" OR 42" UNITS

STEP 1:

Remove base plate from the bottom of bollard pole by removing the (3) 1/4"-20 flat head screws at base of pole. See **Figure 4**.

STEP 2:

Remove all washers and nuts supplied on the anchor bolts and then place base plate over anchor bolts.

STEP 3:

Secure by placing a washer and nut on anchor bolts and tighten.

STEP 4:

Loosen 3/8"-16 pan head screw located at the arm base of optic assembly using a T-45 torx socket and ratchet. See **Figure 5**.

STEP 5:

Lift optic assembly from pole.

STEP 6:

Pull wires up through pole and then reattach pole to base with the (3) 1/4" -20 flat head screws removed in Step 1.

STEP 7:

Make wiring connections per **Electrical Connection** section.

STEP 8:

Reposition optical assembly onto pole and secure by torquing the 3/8"-16 pan head screw to 240 in-lb. See **Figure 6**.

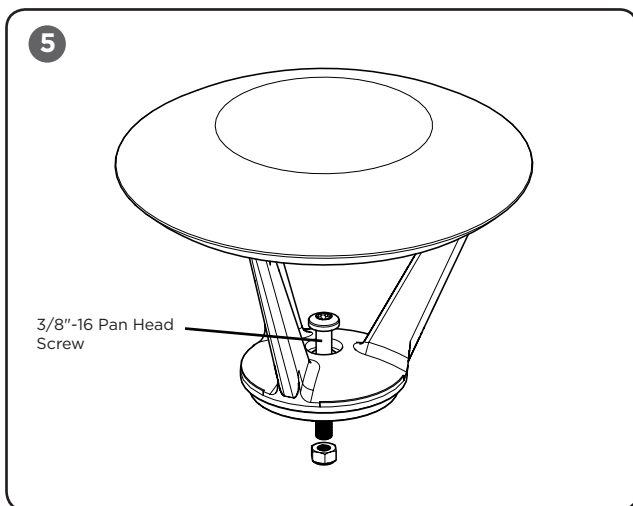

INSTALLATION FOR 96" UNITS

STEP 1:

Remove all washers and nuts supplied on the anchor bolts and then place base plate and pole assembly over the anchor bolts.

STEP 2:

Secure by placing a washer and nut on anchor bolts and tighten.

STEP 3:

Loosen 3/8"-16" pan head screw located at the arm base of optic assembly using a T-45 torx socket and ratchet. See **Figure 5**.

STEP 4:

Lift optic assembly from pole and pull wires through.

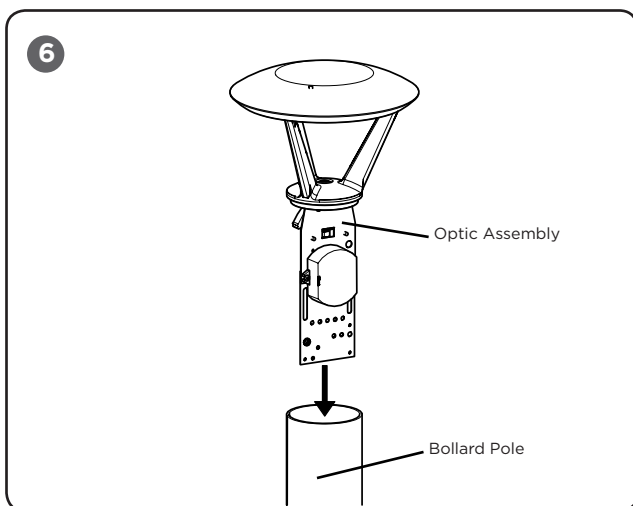

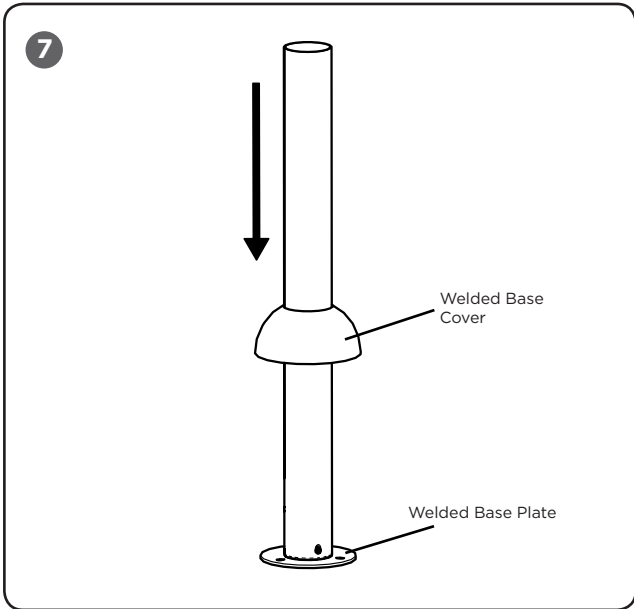

STEP 5:

Slide the Welded Base Cover over the pole cover the Welded Base Plate. See **Figure 7**.

STEP 6:

Make wiring connections per **Electrical Connection** section.

STEP 7:

Reposition optical assembly onto pole and secure by torquing the 3/8-16 pan head screw to 240 in-lb. See **Figure 6**.

ELECTRICAL CONNECTIONS

STEP 1:

Make the following Electrical Connections to the terminal block:

- a. Connect the black luminaire lead to the line supply lead.
- b. Connect the white luminaire lead to the neutral supply lead.
- c. Connect the green/yellow luminaire lead to the supply ground lead.

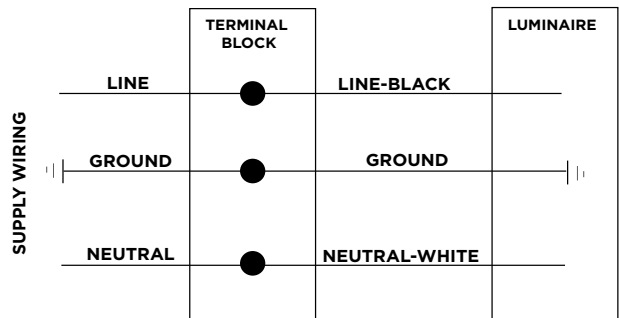

Musco Sports Lighting: Budget Estimate

July 2023

Emerson Skate Park
Grand Junction, Colorado

Thank you for the opportunity to discuss Musco’s Light-Structure System with TLC for LED™ Total Light Control and the benefits it will bring to the Emerson Skate Park . We are excited to offer this innovative system, and are confident you will see the value for many years to come.

This estimate includes Musco’s Light-Structure System with TLC for LED™ along with estimated installation costs. This system includes pre-cast concrete bases, galvanized steel poles, remote electrical component enclosures, pole length wire harnesses and factory-aimed and assembled luminaries.

Benefits of Musco’s Light-Structure System with TLC for LED™

- Guaranteed light levels
- Control-Link® System for remote on/off control and performance monitoring with 24/7 customer support
- Reduction of spill light and glare by 50% or more
- Reduction of energy and maintenance costs by 50% to 85% over typical 1500w HID equipment
- Product assurance and warranty program that includes materials and onsite labor, eliminating 100% of your maintenance costs for 25 years.

Estimated Project Cost: Materials and Installation

Skate Park.....\$270,000-\$295,000

Pricing is based on July 2023 pricing and is subject to change.

This **estimate** includes anticipated equipment and installation costs. This estimate assumes 480v/3 phase power being located within 100’ of the site. It does not include the cost of a new electrical transformer. It also assumes standard soil conditions. Rock, bottomless, wet or unsuitable soil may require additional engineering, special installation methods and additional cost. Assuming use of existing electrical service.

Stephen Baker
Sales Representative
Musco Sports Lighting, LLC
Phone: 720-614-1115
E-mail: Stephen.baker@musco.com





Project Name: Grand Junction Skate Park @ Emerson Park
 Project Number:
 Date: 8.11.23 REV 7

No.	Item Description	Quantity	Unit	Size	Notes	Unit Cost	Total Cost
Phase 2 Design and Construction Docs							
1	Survey	1	LS	-	For planning and construction including final asbuilts	\$ -	\$ 20,000.00
2	Geotech	1	LS	-	Completed	\$ -	\$ -
3	Design Development	1	LS	-		\$ -	\$ 25,000.00
4	Construction Documents Development & Specs	1	LS	-		\$ -	\$ 61,875.00
5	Parking Lot Expansion	1	LS	-		\$ -	\$ 12,500.00
6	Landscape Design	1	LS	-		\$ -	\$ 12,500.00
7	Irrigation Plan	1	LS	-		\$ -	\$ 12,500.00
8	Conceptual Lighting Plan	1	LS	-	Musco will provide NC	\$ -	\$ 3,125.00
9	Traffic Study	1	LS	-		\$ -	\$ 18,750.00
10	Public Input Meetings	1	LS	-	Is the city requesting more contact with the community?	\$ 5,000.00	\$ 7,812.00
Site Prep Total						\$ 5,000.00	\$ 174,062.00
Sitework							
11	Permitting (City & CDEP Contruction)	1	EA	-	City permitting cost & CDEP Construction Permit	\$ 650.00	\$ 650.00
12	Mobilization	1	LS	-		\$ 40,000.00	\$ 40,000.00
13	Construction Safety Fencing	1	LS	-	Quote 7/17 entire site	\$ 7,239.29	\$ 7,239.29
14	Locate Utilites	1	LS	-		\$ 500.00	\$ 500.00
15	Tree Trimming	1	EA	-		\$ 10,000.00	\$ 10,000.00
16	Tree protection & Site Erosion Control	1	EA	-		\$ 8,000.00	\$ 8,000.00
17	Clearing & Grubbing	1	EA	-		\$ 10,500.00	\$ 10,500.00
18	Prepare subgrade for sidewalks	15,146	SF	-		\$ 0.30	\$ 4,543.80
19	Export of spoils		EA	-	unknown at this time	\$ -	\$ -
20	Import Soil		EA	-	unknown at this time	\$ -	\$ -
21	Compaction Testing	1	EA	-		\$ 3,000.00	\$ 3,000.00
22	Demo & Removal of Bathrooms	1	EA	-		\$ 22,000.00	\$ 22,000.00
23	Demo & Removal of Playground	1	EA	-		\$ 15,000.00	\$ 15,000.00
24	Demo & Removal of Curb & Gutter	300	LF	-		\$ 18.00	\$ 5,400.00
25	Demo & Removal of Asphalt Pavement	4,565	SF	-		\$ 2.00	\$ 9,130.00
26	Parking lot - Paving	4,565	SF	-		\$ 6.50	\$ 29,672.50
27	Parking lot - Add Curb & Gutter	945	LF	-		\$ 37.00	\$ 34,965.00
28	Parking lot - Striping	1	EA	-		\$ 1,500.00	\$ 1,500.00
Site work Total						\$ 118,453.09	\$ 202,100.59
Skate Park Construction							
29	Insurance & Bonds	1	LS	-	Calculated at 2%	\$ 25,710.00	\$ 25,710.00
30	Fine Grading	21,425	SF	-		\$ 11.13	\$ 238,358.00
31	Forming Materials	21,425	SF	-		\$ 16.69	\$ 357,537.00
32	Rebar	21,425	SF	-		\$ 6.68	\$ 143,014.80
33	Concrete	21,425	SF	-		\$ 16.13	\$ 345,619.10
31	Metal / Welding work	21,425	SF	-		\$ 5.01	\$ 107,261.10
32	Concrete Testing	1	LS	-		\$ 5,000.00	\$ 5,000.00
33	Travel & Housing	1	LS	-		\$ 60,000.00	\$ 60,000.00
34	As Builts	1	LS	-		\$ 3,000.00	\$ 3,000.00
Skate Park Construction Total						\$ 90,765.63	\$ 1,285,500.00
Site Amenities							
35	6' Sidewalks	15,146	SF	-		\$ 11.00	\$ 166,606.00
36	Benches & Seating areas	6	EA	-		\$ 1,370.59	\$ 8,223.54
37	Trash Enclosures	4	EA	-		\$ 1,677.44	\$ 6,709.76
38	Recycle Enclosures	2	EA	-		\$ 1,677.44	\$ 3,354.88
39	Shade Structures		EA	-		\$ -	\$ -
40	Planters and Decorative Walls	988	SF	-		\$ 105.00	\$ 103,740.00
41	Irrigation - Permanent & Temporary	1	LS	-		\$ 12,000.00	\$ 12,000.00
43	Plantings / restoration of disturbed areas during construction	4,000	SF	-		\$ 10.00	\$ 40,000.00
44	Portable Bathroom Enclosure	1	EA	-		\$ 3,000.00	\$ 3,000.00
45	Dog Waste Station	2	EA	-		\$ 279.99	\$ 559.98
46	Water Fountain / Bottle Filler	1	EA	-		\$ 1,500.00	\$ 1,500.00
47	Lighting	1	LS	-	Estimated from Musco	\$ 275,000.00	\$ 275,000.00
48	Bike Loop Rack	6	EA	-		\$ 673.73	\$ 4,042.38
Hardscape Total						\$ 297,305.19	\$ 624,736.54
Subtotal						\$ 511,523.91	\$ 2,286,399.13
10% Contingency						\$ 51,152.39	\$ 228,639.91
Grand Total						\$ 562,676.30	\$ 2,515,039.04