

UNITED STATES
DEPARTMENT OF THE INTERIOR
BUREAU OF LAND MANAGEMENT

RIGHT-OF-WAY GRANT/TEMPORARY USE PERMIT

Issuing Office
Grand Junction Field Office

Serial Number
COCO106362504

1. A (right-of-way) (permit) is hereby granted pursuant to:

- a. Title V of the Federal Land Policy and Management Act of October 21, 1976 (90 Stat. 2776; 43 U.S.C. 1761);
- b. Section 28 of the Mineral Leasing Act of 1920, as amended (30 U.S.C. 185);
- c. Other (describe) _____

2. Nature of Interest:

- a. By this instrument, the holder City of Grand Junction receives a right to construct, operate, maintain, and terminate a Temporary work area for Monument Connector Trail on public lands (or Federal land for MLA Rights-of-Way) described as follows:

Ute Meridian, Colorado
T. 1 S., R. 1 W.,
sec. 28, lot 4;
sec. 29, SW1/4NE1/4.

- b. The right-of-way or permit area granted herein is 5 feet wide, 1,024 feet long and contains 0.12 acres, more or less. If a site type facility, the facility contains NA acres.
- c. This instrument shall terminate on 03/28/2027, 3 years from its effective date unless, prior thereto, it is relinquished, abandoned, terminated, or modified pursuant to the terms and conditions of this instrument or of any applicable Federal law or regulation.
- d. This instrument may may not be renewed. If renewed, the right-of-way or permit shall be subject to the regulations existing at the time of renewal and any other terms and conditions that the authorized officer deems necessary to protect the public interest.
- e. Notwithstanding the expiration of this instrument or any renewal thereof, early relinquishment, abandonment, or termination, the provisions of this instrument, to the extent applicable, shall continue in effect and shall be binding on the holder, its successors, or assigns, until they have fully satisfied the obligations and/or liabilities accruing herein before or on account of the expiration, or prior termination, of the grant.

3. Rental:

For and in consideration of the rights granted, the holder agrees to pay the Bureau of Land Management fair market value rental as determined by the authorized officer unless specifically exempted from such payment by regulation. Provided, however, that the rental may be adjusted by the authorized officer, whenever necessary, to reflect changes in the fair market rental value as determined by the application of sound business management principles, and so far as practicable and feasible, in accordance with comparable commercial practices.

4. Terms and Conditions:

- a. This grant or permit is issued subject to the holder's compliance with all applicable regulations contained in Title 43 Code of Federal Regulations parts 2800 and 2880.
- b. Upon grant termination by the authorized officer, all improvements shall be removed from the public lands within 90 days, or otherwise disposed of as provided in paragraph (4)(d) or as directed by the authorized officer.

- c. Each grant issued pursuant to the authority of paragraph (1)(a) for a term of 20 years or more shall, at a minimum, be reviewed by the authorized officer at the end of the 20th year and at regular intervals thereafter not to exceed 10 years. Provided, however, that a right-of-way or permit granted herein may be reviewed at any time deemed necessary by the authorized officer.
- d. The stipulations, plans, maps, or designs set forth in Exhibit(s) A, B, and C, dated 03/28/2024, attached hereto, are incorporated into and made a part of this grant instrument as fully and effectively as if they were set forth herein in their entirety.
- e. Failure of the holder to comply with applicable law or any provision of this right-of-way grant or permit shall constitute grounds for suspension or termination thereof.
- f. The holder shall perform all operations in a good and workmanlike manner so as to ensure protection of the environment and the health and safety of the public.

IN WITNESS WHEREOF, The undersigned agrees to the terms and conditions of this right-of-way grant or permit.

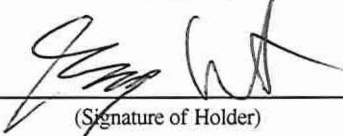

 (Signature of Holder)

CITY MANAGER

 (Title)

4/2/2024

 (Date)



 (Signature of Authorized Officer)

Field Manager (acting)

 (Title)

4/2/2024

 (Effective Date of Grant)

EXHIBIT A. PROJECT MAPS

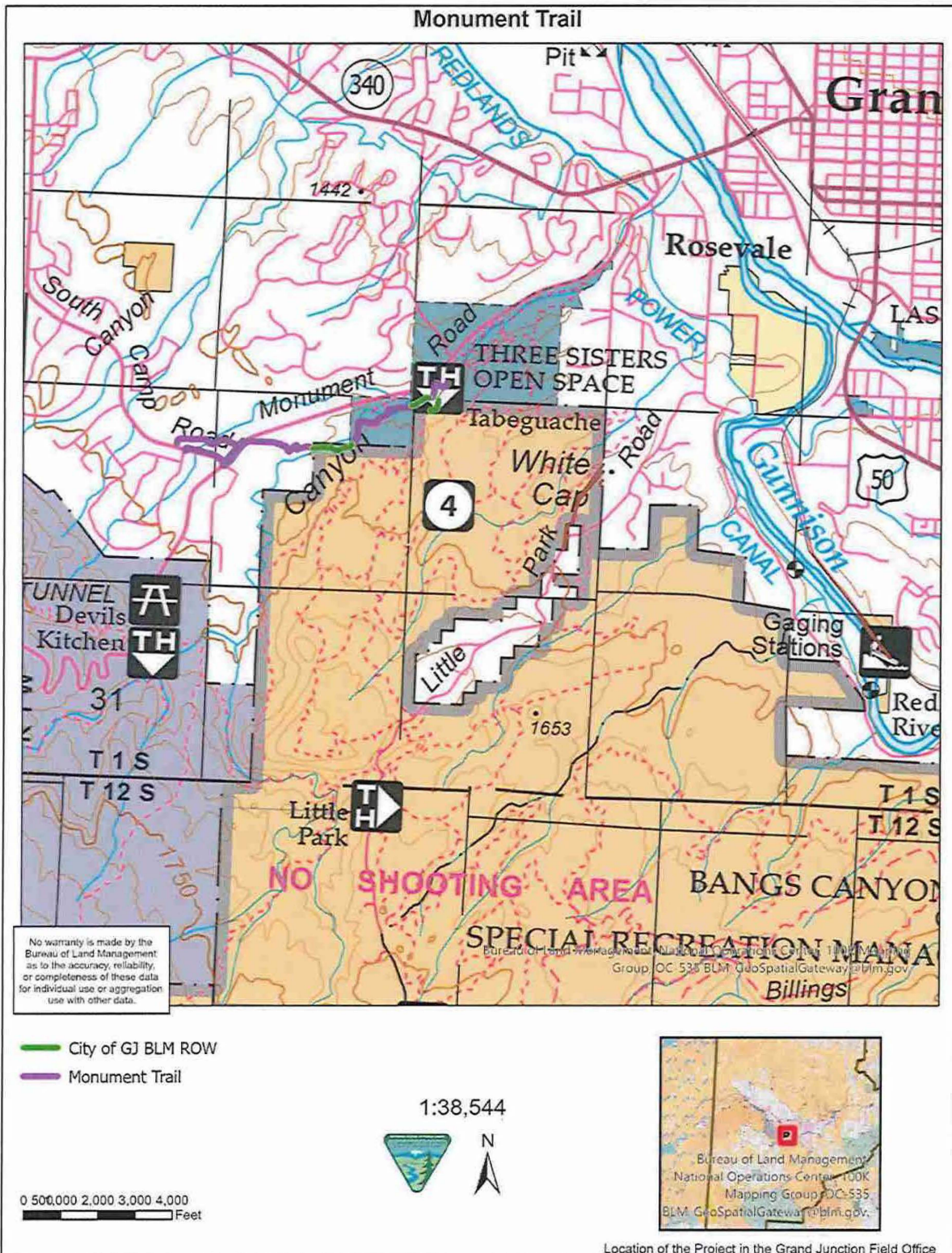

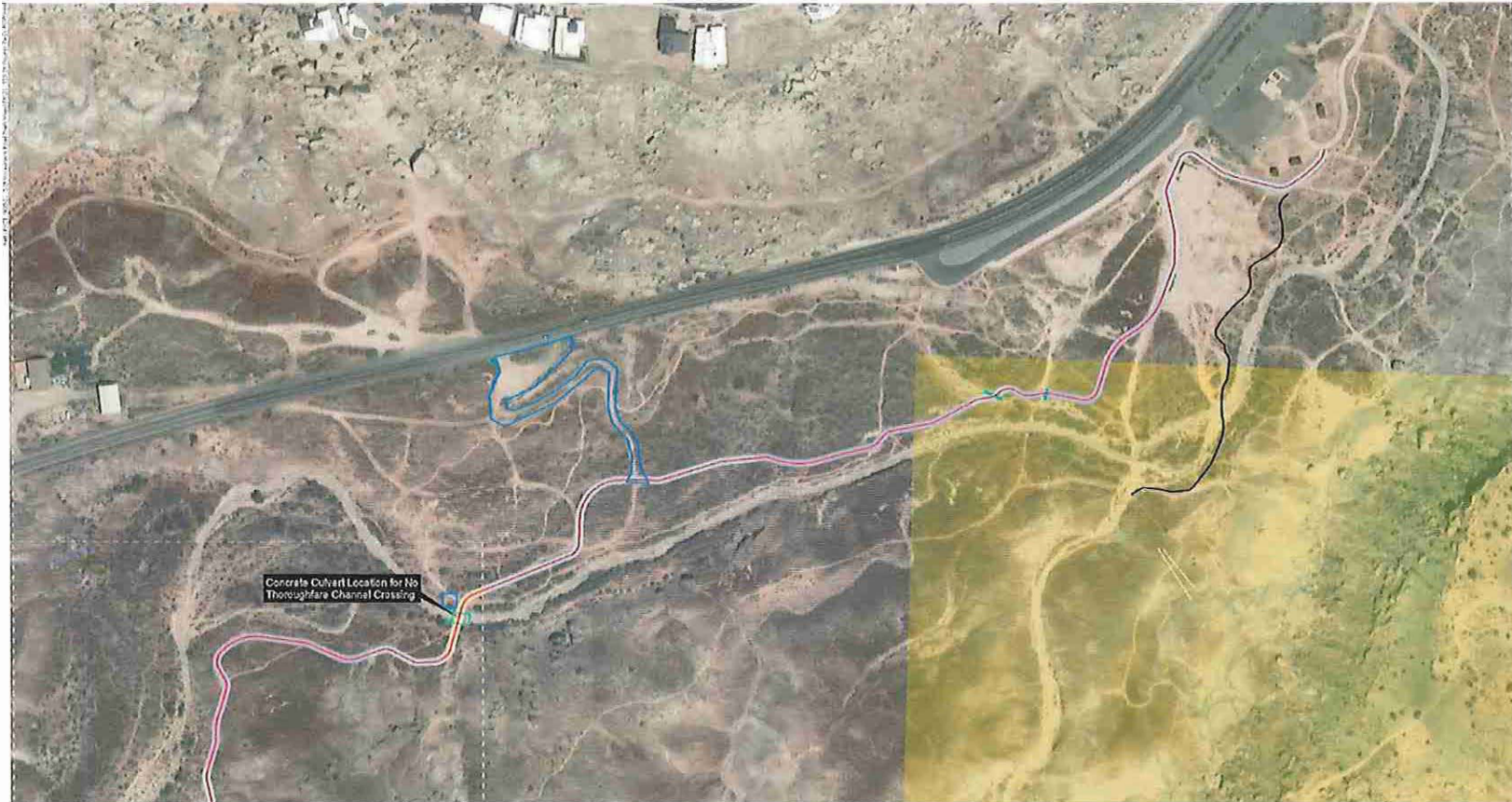

Monument Connector Trail Biological Assessment

- Survey Marker
- Proposed Paved Trail
- Proposed Singletrack Trail
- Proposed Culvert
- Staging Area
- BLM Land
- Designated Right of Way (ROW) Widths
- 22-Foot Permanent and Temporary ROW
- 35-Foot Permanent ROW, 40-Foot Temporary ROW
- 50-Foot Permanent and Temporary ROW

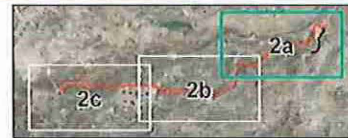

Figure 2a
Project Location

Image Source: Maxar Technologies ©, August 5, 2021



Prepared for: City of Grand Junction
File: 21_1119181_10000_2a-2c_102021.dwg
March 29, 2024



Review of this document is the sole responsibility of ERO and its users and is not intended to be used for any other purpose. Copyright © 2024 ERO, All rights reserved.

EXHIBIT B. STIPULATIONS

SPECIAL STATUS SPECIES (Colorado hookless cactus)

1. The disturbance width along the trail will be confined to 22 feet in areas where CHC is located.
2. Construction equipment including concrete trucks will use the trail corridor as a travel way during construction.
3. All new soil-disturbing activities will be greater than 20 meters from current occupied CHC locations*.
4. Use of an access route during construction will not result in new disturbance to two CHC individuals located 18 meters from the route due to topography and existing disturbance/access use.
5. Dust-suppression measures will be used to control fugitive dust from access routes and areas of disturbance in the vicinity of the trail alignment.
6. All new soil-disturbing activities will be greater than 20 meters from current occupied CHC locations (mentioned previously)*.
7. Construction activities will occur outside of the blooming season (April 1 to June 30) to minimize impacts on pollination/pollinators.
8. Measures to control the spread of weeds will be conducted per the requirements in the BLM GJFO Integrated Weed Management Plan (BLM 2017) (mentioned previously).
9. Gravel will be procured from a weed free source to limit the introduction of knapweed or other invasives.

Additional general design features incorporated in the proposed action are listed below:

1. All staff, contractors, and volunteers responsible for any element of on-the-ground work will receive environmental awareness training prior to being allowed to work on this project. Training will include: (a) information on the legal and biological status of CHC, (b) the habitats important to the species, (c) awareness of mandatory conservation/avoidance measures, (d) information on fines and penalties for damaging or directly impacting CHC, and (e) reporting procedures if any violation occur.
2. Any unrecorded/new cactus documented during construction will be avoided, and the minimization measures/design features will be applied to these individuals.
3. All tools and equipment used for trail construction will be cleaned to prevent weed infestations. Disturbed areas will be reseeded with a BLM-approved seed mix.
4. The BLM and City will monitor for the presence of noxious weeds and control undesirable plants in disturbed areas.
5. The BLM and City will coordinate to close and potentially rehabilitate social trails near CHC.

and termination. Noncompliance with the above are grounds for an immediate temporary suspension of activities if it constitutes a threat to public health and safety or the environment.

2. The holder must notify the BLM authorized officer at least 90 days prior to non-emergency activities that will cause surface disturbance in the right-of-way. A "Notice to Proceed" must be required prior to any non-emergency activities that will cause surface disturbance on the right-of-way. Any request for a "Notice to Proceed" must be made to the authorized officer, who will review the proposed action for consistency with resource management concerns such as special status species, cultural resource protection, and wildlife. The authorized officer may require the completion of special status species surveys or other resource surveys and monitoring by a third-party contractor at the expense of the holder. Additional measures may be required to protect special status species or other resources.
3. Construction sites must be maintained in a sanitary condition at all times; waste materials at those sites must be disposed of promptly at an appropriate waste disposal site. "Waste" means all discarded matter including, but not limited to, human waste, trash, garbage, refuse, oil drums, petroleum products, ashes, water used for pressure testing, and equipment.
3. Holder must maintain the ROW in a safe, useable condition, as directed by the Authorized Officer (AO) (A regular maintenance program must be included in the POD).
4. The BLM will approve all signs place on federal use or that indicate allowed uses on federal land. Uses on federal lands will be allowed in accordance with federal rules, regulations, and policies.
5. Use of pesticides and herbicides must comply with the applicable Federal and State laws. Pesticides and herbicides must be used only in accordance with their registered uses and within limitations imposed by the Secretary of the Interior. Prior to the use of pesticides, Holder must obtain from the AO written approval of a plan showing the type and quantity of material to be used, pest(s) to be controlled, method of application, location of storage and disposal of containers, and any other information deemed necessary by the AO. Emergency use of pesticides must be approved in writing by the AO prior to use.
6. For projects with surface disturbance equal to or greater than one acre, a stormwater permit and stormwater management plan (SWMP) is required by the State of Colorado. Best Management Practices (BMPs) identified in the SWMP must be in place prior to any surface-disturbing activity. The holder must install additional BMPs as determined necessary by the authorized officer.
7. Holder of this right-of-way agrees to indemnify the United States against any liability arising from the release of any hazardous substance or hazardous waste (as these terms are defined in the Comprehensive Environmental Response, Compensation and Liability Act of 1980, 42 U.S.C. 9601, *et seq.* or the Resource Conservation and Recovery Act, 42 U.S.C. 6901, *et seq.*) on this ROW (unless the release or threatened release is wholly unrelated to Holder's activity in this ROW). This agreement applies without regard to whether a release is caused by the Holder, their agent, or unrelated third parties.

will immediately report fires to the BLM Authorized Officer (970) 244-3000 or local fire dispatch (970) 257-4800 and take all necessary fire suppression actions, when safe to do so, with their personnel and equipment on any fires they cause to ignite.

7. Holder must maintain the condition of the origin area of the fire from further damage to enable the Fire Investigator to properly assess the origin area and cause of the fire. The Holder must report to the Fire Investigator or BLM Incident Commander and must not enter into the origin area on fires unless given permission to do so.
8. The Holder will cooperate with the BLM in its efforts to investigate, suppress and respond to all future fires. The duty to “cooperate” includes, but is not limited to, the following duties regardless of whether BLM is on the scene:
 - i. The duty to provide the BLM (Authorized Officer (970) 244-3000 or local fire dispatch (970) 257-4800 with reasonable and timely notice concerning all fires involving the Holder’s facilities or discovered during routine operations.
 - ii. The duty to share factual information with the BLM concerning fires, including but not limited to the names of Holder’s employees and/or contractors with knowledge of the incident; and to allow employees and/or contractors to be interviewed by BLM’s investigators regarding factual information relating to a fire.
 - iii. It is the duty of the Holder to preserve the point of ignition, fire scene and reasonably account to the BLM for Holders actions taken at the scene of a fire.
 - iv. The duty to minimize disturbance of potential evidence located at the scene; to not engage in any evidence collection or destructive testing without BLM and or its counsel’s express written consent; to properly handle and preserve any evidence collected and to make all documents and evidence, including expert reports, available to the BLM in a rapid and timely manner upon request of BLM and/or its counsel.
 - v. The duty to not hamper the BLM investigation of origin and cause of the fire; and to reasonably assist BLM’s investigation at the scene.
 - vi. The duty to provide information upon request of BLM and/or its counsel concerning the construction, monitoring, inspection, maintenance and/or repairs of any of Holder’s facilities located at or adjacent to a fire.
 - vii. The duty to provide information upon request of BLM and/or its counsel concerning the monitoring, inspection, and or alteration by Holder of any condition on public land, including but not limited to, public land adjacent to any of the Holder’s facilities.
 - viii. The duty, during BLM fire suppression efforts: to defer to and follow the instructions of the BLM’s Incident Commander regarding activities within the boundaries of the fire and checking in and out of the fire; and to recognize BLM’s primary authority over the incident scene.

with soils mapped as Mancos shale, application of water on native road surfaces will be limited, to minimize mobilization of selenium. In such areas, alternate dust abatement measures such as proper road surfacing and maintenance, and speed limits will be used, subject to BLM approval.

M&E-61: Cut and fill slopes will be protected against erosion by contour grading, microbasins or other measures approved by the BLM. Well anchored BMPs such as biodegradable matting, weed-free bales or wattles may also be used on cut-and-fill slopes and along drainages to protect against soil movement.

VR-10: Ensure that seed used for revegetation as well as straw and hay bales used for erosion control are certified free of noxious weeds.

V-14: Perform final reclamation recontouring of all disturbed areas, including access roads, to the original contour or a contour that blends with the surrounding topography.

WEED-11: Minimize soil disturbance. To the extent practicable, native vegetation must be retained in and around project activity areas, and soil disturbance kept to a minimum.

WEED-19: Remove mud, dirt, and plant parts from project equipment before moving it into a project area. Seeds and plant parts must be collected and incinerated when practical, or washed off in an approved containment area.

WEED-25: Clean all equipment (power or high-pressure cleaning) of all mud, dirt, and plant parts before leaving the project site if operating in areas infested with weeds. Seeds and plant parts must be collected and incinerated when possible.

WEED-26: When seeding has been specified for construction and maintenance activities, seed all disturbed soil (except travel route) soon after work is completed.

WEED-27: Use a certified weed-free seed mix suitable for local environmental conditions that includes fast, early growing (preferably native) species to provide quick revegetation. Consider applying weed-free mulch with seeding. (SOP)

WEED-28: Periodically inspect roads and rights-of-way for noxious weeds. Train staff to recognize weeds and report locations to the local weed specialist. Follow-up with treatment when needed.

WEED-29: When reclaiming roads, treat weeds before roads are made impassable. Inspect and follow up based on initial inspection and documentation.

WEED-30: To avoid weed infestations, create and maintain healthy plant communities whenever possible, including utility rights-of-ways, roadsides, scenic overlooks, trailheads, and campgrounds.

CR-4: The National Historic Preservation Act, as amended, requires that if newly discovered historic or archaeological materials or other cultural resources are identified during project implementation, work in that area must stop and the BLM Authorized Officer must be notified immediately. Within five working days the BLM Authorized Officer will inform the proponent as

- All tools and equipment used for trail construction will be cleaned to prevent weed infestations. Disturbed areas will be reseeded with a BLM-approved seed mix.
- The City will monitor for the presence of noxious weeds and treat noxious weeds in coordination with BLM
- The BLM and City will coordinate to close and potentially rehabilitate social trails near CHC.
- The City will coordinate with the BLM for needed trail maintenance on BLM-managed lands.

Long-term maintenance of the Monument Trail will be performed by the City throughout the life of the trail system. Maintenance will include repair of erosion-control features, culverts, noxious weed treatments, and trail clearing as needed.

CHC normally blooms in April through May, and populations fluctuate over time, requiring new surveys to determine appropriate avoidance activities. Any future construction or maintenance work on the Monument Trail will be coordinated with BLM ecologists, who will determine the extent of monitoring and survey that is required. The BLM will be notified in the fall prior to any planned maintenance work so that spring surveys can take place for CHC in the project area. Only ground-disturbing activities will require BLM coordination.

Paleontological Resources

PR-1 Culvert installation in PYFC 4/5 level areas of the Morrison Formation, Summerville Formation, or Entrada Sandstone. The Unanticipated Discovery Plan below outlines procedures to follow in the event that paleontological resources are encountered during ground-disturbing and other construction activities in the absence of a paleontological resources monitor:

1. Upon discovery/excavation of significant paleontological resources, immediately stop construction activities and inform the on-site construction foreman/supervisor of discovery. Do not attempt to remove the fossils.
2. The construction foreman/supervisor must contact the appropriate personnel (BLM, City, etc.) immediately and notify them of the discovery.
3. A salvage/recovery plan must be formulated with help of a BLM-permitted paleontologist. Construction activities in the area of discovery must be ceased until fossil salvage/recovery is completed and the area is cleared by the appropriate personnel.
4. Areas that were previously excavated in the project area (including associated spoils piles) must be inspected for additional paleontological resources. Paleontological monitoring during subsequent construction activities must be considered for the remainder of the project.

Soils

S-1 All soils compacted by movement of construction vehicles and equipment, will be 1.) loosened and leveled harrowing or disking to approximate pre-construction contours and 2.)

EXHIBIT C. APPLICANT PLAN OF DEVELOPMENT

PLAN OF DEVELOPMENT

City of Grand Junction: Monument Connector Trail

Prepared for—

Bureau of Land Management
Grand Junction Field Office
2815 H Road
Grand Junction, Colorado 81506

Prepared by—

ERO Resources Corporation
161 South 2nd Street
Hotchkiss, Colorado 81419
(970) 872-3020
ERO Project #21-319

March 2024

CONTENTS

1.0 Location, Description, and Design.....3

 1.1 Legal Description..... 3

 1.2 Design..... 4

2.0 Project Purpose and Need4

3.0 General Activities and Equipment.....4

 3.1 Access..... 4

 3.2 Staging and Storage 4

 3.3 Construction Activities 9

 3.4 Patrols and Minor Maintenance Activities..... 10

 3.5 Equipment and Workforce..... 10

 3.6 Staking..... 11

 3.7 Contingency Planning..... 11

 3.8 Safety Requirements..... 11

4.0 Project Activities11

 4.1 Vegetation Management and Site Preparation 11

 4.2 Site Excavation 13

 4.3 Survey..... 14

 4.4 New Access 15

 4.5 Drive-In Access 16

 4.6 Reclamation 16

 4.7 Noxious Weed Plan 17

 4.8 Abandonment 20

 4.9 Survey Monuments..... 20

5.0 Project Schedule20

6.0 Right-of-Way Requirements20

 6.1 Trail Right-of-Way 21

 6.2 Temporary Use Areas..... 21

7.0 Design Features21

 7.1 Cultural Resources 22

 7.2 Paleontological Resources 22

 7.3 Biological Resources..... 22

9.0 Operation and Maintenance24

 9.1 Inspection/Patrols..... 24

 9.2 Work Schedule 25

 9.3 Fire Control 25

 9.4 Notification of BLM 25

 9.5 Emergencies..... 25

10.0 References.....26

FIGURES

- Figure 1. Vicinity Map
- Figure 2a. Location Map 1
- Figure 2b. Location Map 2
- Figure 2c. Location Map 3

Proposed Monument Connector Trail Plan

1.0 Location, Description, and Design

The City of Grand Junction (City) is proposing to construct the Monument Connector Trail Project (project) to provide a continuous shared-use path from Lunch Loops/Tabeguache Trailhead to South Camp Road (trailhead) (project area; Figure 1). The City, in cooperation with the Bureau of Land Management (BLM), Colorado West Land Trust, and Mesa County, completed the Lunch Loops Connector Trail in December 2019 (phase one). The trail connects the Lunch Loops Trailhead to the Colorado Riverfront Trail and Las Colonias. The same organizations are working together to extend the trail from the Lunch Loops Trailhead on the east to South Camp Road on the west in phase two of the project, called the Monument Connector Trail (Monument Trail). The paved trail will be approximately 9,147 feet long with 1,625 feet crossing public lands in two segments in the BLM's Grand Junction Field Office (GJFO) Bangs Canyon Special Recreation Management Area. An additional 858 feet of connecting single-track trail (unpaved) with 416 feet crossing BLM GJFO land is also incorporated into the project. In total, the project will provide 10,005 feet of additional recreation trail (paved and single-track).

The City intends to construct, operate, maintain, and terminate a multiuse concrete trail with aggregate base shoulders on two segments of BLM land. The City has applied to the BLM for a right-of-way (ROW) grant along the trail on BLM land, including a 40-foot-wide temporary construction ROW and a 35-foot-wide permanent ROW, with a 22-foot wide ROW in areas with Colorado hookless cactus and 50-foot wide ROW in areas with concrete box culverts. The permanent ROW will be issued for a term of 30 years and contain terms, conditions, and stipulations. Federal lands crossed by the trail include BLM lands (managed by the GJFO). Detailed maps (Figures 2a through 2c) that display the trail, ownership and management, access points, and proposed activities including impact area are attached.

1.1 Legal Description

Below are the legal descriptions for the trail.

1.1.1 BLM-Managed Lands

NW4 NW4 Sec. 28 T1S R1W

SE4 NE4 Sec. 29 T1S R1W

SW4 NE4 Sec. 29 T1S R1W

1.1.2 City-Owned Lands

SW4 SW4 Sec. 21 T1S R1W

NE4 NE4 Sec. 29 T1S R1W

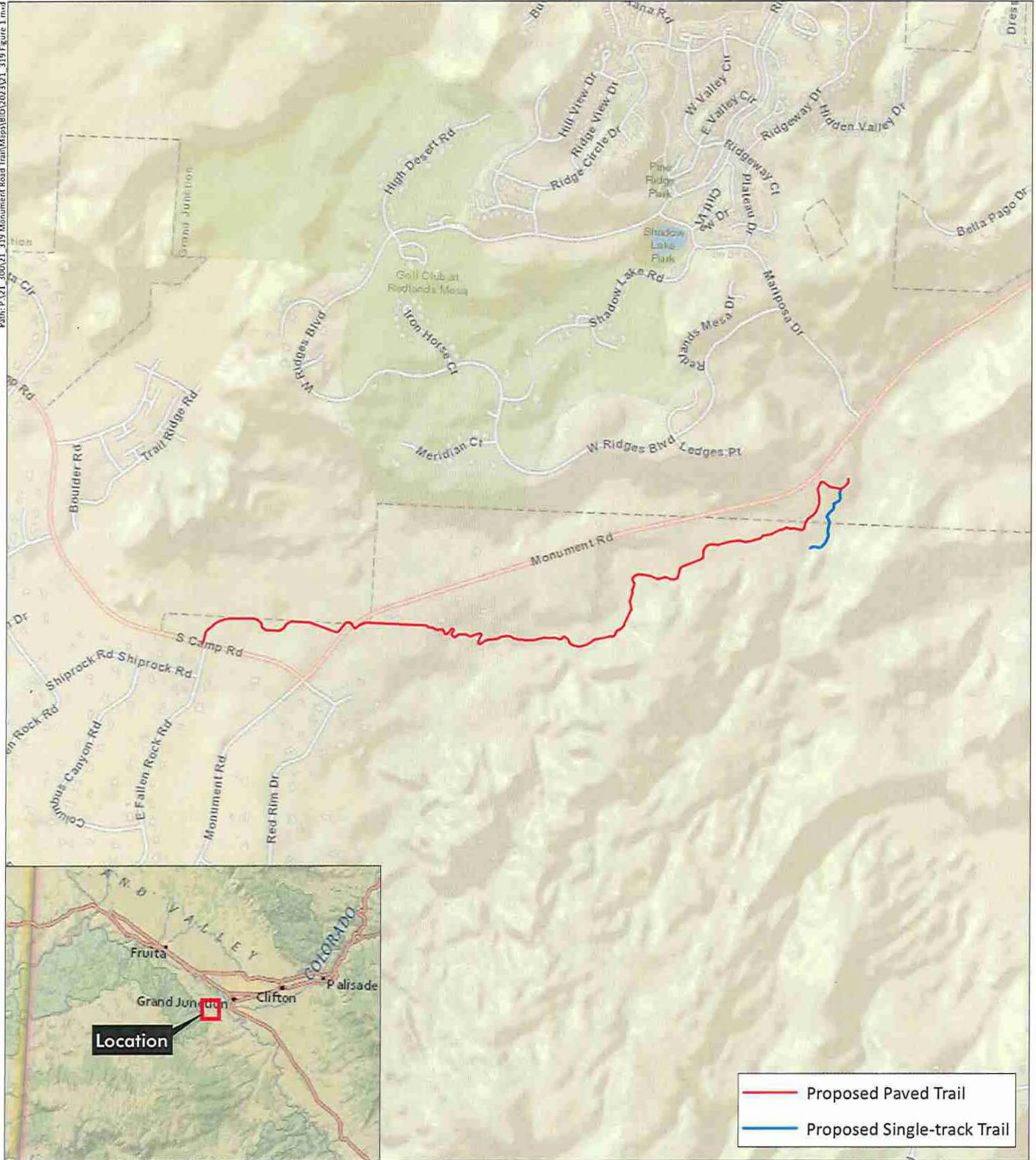

Monument Road Trail Biological Assessment

Sections 21 and 28-30, T1S, R1W; Ute Meridian
 UTM NAD 83: Zone 13N; 706485mE, 4324457mN
 Longitude 108.614061°W, Latitude 39.044802°N
 USGS Colorado National Monument and Grand Junction, CO Quadrangles
 Mesa County, Colorado



Figure 1
Vicinity Map

Prepared for: City of Grand Junction
 File: 21_319 Figure 1.mxd (GS)
 July 28, 2023



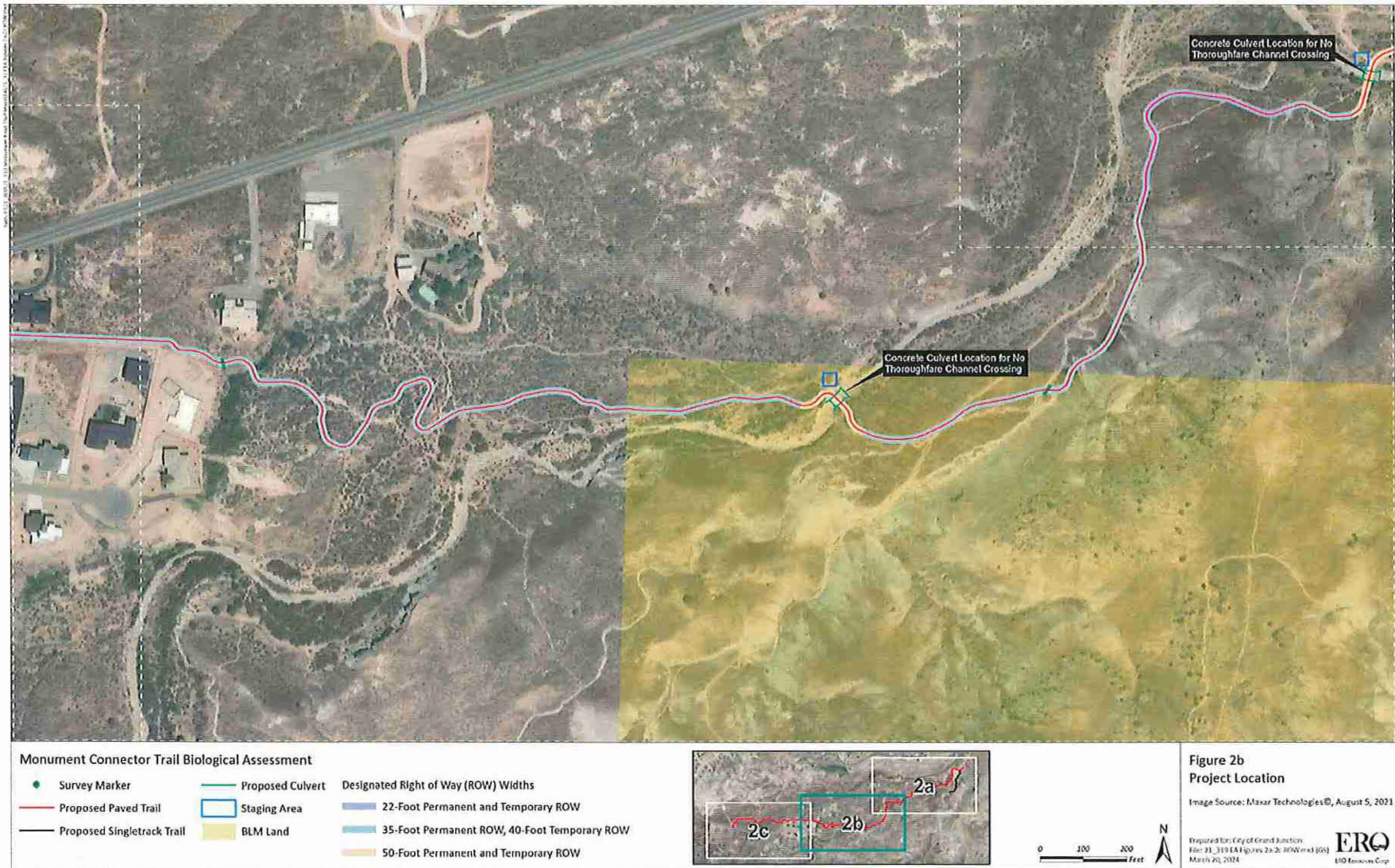

- Three larger staging areas (Figure 2a, one just west of the trailhead parking for the Lunch Loop Trail; and Figure 2c, one at the western terminus of the trail along South Camp Road and one along Monument Road just east of the South Camp Road intersection) and two smaller staging areas where box culverts are needed for crossing the No Thoroughfare channel (see Figure 2b).
- Culverts, aggregate base, concrete forms, and other construction materials will be stored for a short term (typically less than a month) in the staging areas shown on Figures 2a through 2c and within approved ROW except where there is known habitat for threatened, endangered, or sensitive species to be protected (see Section 7.0, Design Features).
- Equipment and vehicle storage will be at City facilities, in the staging areas, or within approved ROW shown on Figures 2a through 2c.

3.3 Construction Activities

The concrete trail would generally follow existing grade and dips in terrain to naturally convey stormflow. In addition to a 16-foot total trail width (10 feet of concrete and 3 feet of shoulder on either side), an additional 7 feet of temporary construction buffer would be needed on both sides of the trail. The estimated maximum depth of excavation for trail construction is not expected to exceed 2 feet, other than the two areas where the trail crosses No Thoroughfare Canyon drainage. Additional design detail information is attached. Construction would follow these basic steps:

- The location of the trail would be excavated and leveled to provide a stable base and drainage for the concrete trail. Slopes would be laid back to prevent sloughing of material into the project working area.
- A concrete slip-form machine would be placed to follow surveyed string line, and concrete would be trucked in, poured, and set/cured. Aggregate base would be placed on either side of the trail for the shoulders. The anticipated quantities of material and number of trucks are shown in Table 1.
- Following construction, all disturbed areas would be regraded/contoured, seeded, and managed to prevent weed infestation.

Table 1. Tons of construction material and truck loads required.

Material	Tons	Truck Loads
Aggregate base	6,300	630
Concrete	3,400	170

The trail crosses the No Thoroughfare Canyon drainage in two places (Figure 2b). Two dual flood stage concrete box culverts (see Appendix A) would be installed where the trail crosses the channel, and extra working space around the culverts would be needed during construction (a total of 50 feet of permanent use for the span (100 feet either side of culvert centerline) of the culverts to accommodate operations and maintenance). A space of about 30 feet by 30 feet

- Concrete truck (1-3 at a time; 1 operator per truck with 2-4 people assisting)
- Rubber-tired backhoe/trackerhoe (1; 1 operator)
- Small crane (1; 1 operator)
- Air compressor (1; personnel noted above)
- Hand tools including shovels and jackhammers (various numbers; personnel noted above)

3.6 Staking

Before construction commences, the construction surveyor will stake the proposed improvements on-site as shown in the construction documents. During construction, the surveyor will update any damaged or missing stakes as needed.

3.7 Contingency Planning

Contingency planning during construction will include communication priority (depending on injury or non-injury incident) and steps to take for a potential pollution spill. Potential for pollution at the project site will most likely come from the vehicles used to import materials (dump trucks, concrete trucks, cranes, etc.) and to grade and compact the trail subgrade (road grader and wheel drum compactor). The contractor will develop a contingency plan (Spill Prevention and Response Plan) to mitigate a potential pollution spill from a piece of equipment. The following spill control procedures will be implemented: containment, vessel, tank, and piping inspection and maintenance; spill response, containment and cleanup; and company policies on reporting and responding to spills. When not in use, all equipment will be parked in one of the three proposed construction access areas and protected from potential flooding.

3.8 Safety Requirements

City staff and construction workers will be required to wear Personal Protective Equipment (PPE) while working on site. PPE includes a hardhat, a safety vest, closed-toe boots, and safety glasses (gloves and hearing protection as needed). The contractor will host daily safety talks prior to commencing work each day.

4.0 Project Activities

4.1 Vegetation Management and Site Preparation

Overland construction methods will be used for vegetation management requirements, in addition to use of the authorized access and along the approved ROW. The clearing of vegetation may be required when necessary to support trail construction. There are a limited number of trees and shrubs located along most of the trail alignment (see Photo 1 and Photo 2 for representative vegetation conditions). Vegetation communities in the project area include sandy greasewood flats, sandy washes/disturbed areas, and salt desert scrub (see additional information on vegetation communities and dominant species in the project Biological Assessment). Primary shrubby vegetation that would require clearing includes greasewood,

Photo 2. Representative woody vegetation conditions.



4.2 Site Excavation

As noted above, the City has requested a 40-foot-wide temporary construction ROW across BLM lands and a 35-foot-wide permanent ROW. The proposed trail would be a 10-foot-wide concrete surface, with 3-foot-wide aggregate base course shoulders on either side (16 feet total). The single-track trail would be 4 feet wide.

A bulldozer would be used to clear and level the trail alignment after vegetation removal has been conducted. The intent, as noted previously, is to follow the natural topography and conduct fill or excavation at no more than 2 feet throughout the project area except in steeper areas and adjacent to the box culverts.

A proposed cross section of the trail is shown below.

The entire trail corridor on BLM and City-owned lands, including trail components and access routes, and respective buffer zones have been surveyed for cultural resources (see Archaeological Survey Findings Report). ERO surveyed a total of 42.8 acres, which includes the entire trail alignment with a 75-foot buffer (150-foot temporary ROW) (area of potential effect [APE]). Land within the APE is administered by the BLM (7.1 acres) and the City (35.7 acres). ERO archaeologists Kathy Croll and John Zachman conducted a Class III cultural resource survey of the entire APE on December 13, 2021, and May 10, 2022 (ERO 2022a).

Based on the presence of a fossiliferous sedimentary geologic formation in the project area, a preconstruction paleontological resources survey was requested by the BLM GJFO. Western Slope Paleontological Services (WSP) performed a pedestrian paleontological resources survey of the proposed trail alignments for 5 days in February, March, and April 2022. The survey was conducted in accordance with BLM Colorado Paleontological Resources Use Permit #COC76202 issued to Josh A. Smith of WSP on February 9, 2022, and expiring on December 31, 2022 (WSP 2022).

Raptor surveys were completed within a 1-mile buffer of the trail and maintenance access routes. A qualified biologist conducted the surveys in compliance with the “BLM Grand Junction Field Office (GJFO) Standards for Contractor Inventories for Special Status Plants, Significant Plant Communities & Noxious Weeds” on several dates both within and outside of the blooming season for Colorado hookless cactus (CHC) and the other target plant species. The survey included a 20-meter (66-foot) survey buffer and 60 meters (197 feet) on each side of the trail construction disturbance width (22-foot width), as well as a 20-meter buffer adjacent to staging areas and a temporary access route. The project design was adjusted after the initial survey to avoid impacts on CHC found; subsequent survey was required due to these changes as well as the identification of staging and access areas. The dates surveyed were April 20, 2022 (phenology check); May 13, 2022; and July 22, 2022. Transects were walked throughout the project area and varied depending on habitat, ranging from about 10 to 15 feet to about 2 to 3 feet in suitable habitat and when specimens were encountered. Disturbed, bare, greasewood flats and other unsuitable habitat areas were walked at wider transects. The May 2022 survey, conducted during blooming season when the CHC are more visible, also used wider transects in nonsuitable habitat. The July survey was conducted using 3- to 5-foot transects due to lower visibility, even in marginally suitable habitat. General vegetation communities and noxious weeds were surveyed (ERO 2022b).

A wetland delineation was conducted to identify the need for Clean Water Act permitting (ERO 2022c).

4.4 New Access

There will be no new access roads needed for the City trail activities.

Common Name	Scientific Name	PLS (lbs/ac)
Thickspike wheatgrass	<i>Elymus lanceolatus</i>	2.3
Western wheatgrass	<i>Pascopyrum smithii</i>	7.5
Bluebunch wheatgrass	<i>Pseudoroegneria spicata</i>	2.3
Slender wheatgrass	<i>Elymus trachycaulus</i>	9.5
Red Mexican hat	<i>Ratibida columnifera</i>	0.5
Blanket flower	<i>Gaillardia</i>	1.5
Western yarrow	<i>Achillea millefolium</i>	0.5
	TOTAL	25.00

Hydroseed all disturbed areas at the construction site per subsection 212. Soil compaction shall be minimized for areas where permanent stabilization will be achieved through vegetative cover. PLS = pure live seed.

Table 3. BLM seed mix, greasewood flats, desert scrubland.

Common Name	Scientific Name	Variety	Percentage of Mix (%)	PLS (lbs/ac)
Western wheatgrass	<i>Pascopyrum smithii</i>	Arriba, Rosana	35	9.5
Bottlebrush squirreltail	<i>Elymus elymoides</i>	VNS	22	5.8
Alkali sacaton	<i>Sporobolus airoides</i>	VNS	1	0.27
Sand dropseed	<i>Sporobolus cryptandrus</i>	VNS	<1	0.09
Shadscale	<i>Atriplex confertifolia</i>	VNS	17	4.5
Four-wing saltbush	<i>Atriplex canescens</i>	Source N of CO-NM line or above 5,000 ft	23	6.2
Scarlet globemallow	<i>Sphaeralcea coccinea</i>	VNS	2	0.47
		TOTAL	100	26.83

Must be able to verify source. Double seeding rate for broadcast seeding. All seed will be certified weed free.

The reclamation procedures described above will be applied to all areas that result in temporary disturbance to vegetation greater than about 2 to 3 square feet, except where sensitive species are within 20 feet of disturbed areas and the City has been directed to avoid seeding activities.

4.7 Noxious Weed Plan

When native vegetation is disturbed, opportunities arise for populations of weedy species to increase or to invade disturbed areas. Disturbed corridors along access roads are particularly vulnerable to the increase of weedy vegetation. Invasive populations of weedy species often outcompete and can directly impact native plant populations, including special status species. Other impacts from an increase in weed infestations include the loss of forage for wildlife, decreased availability of habitat for wildlife, and a loss of biodiversity relative to undisturbed areas.

Weeds can be introduced during projects by vehicles, through improper treatment of equipment, and through revegetation seed mixtures. Wildlife, wind dispersal, and spreading by livestock are non-project-related means of increasing weedy species.

The City Parks department will be responsible for weed control after construction of the trail. Colorado West Land Trust may assist the City with trail maintenance and noxious weed control, pre- and postconstruction (they have assisted with this in the past on phase one). All chemical weed control will be in accordance with the BLM-approved herbicide formulations updated on April 4, 2019, except that the City no longer uses glyphosate. Noxious weed populations identified along the alignment will be treated by the City with BLM-approved chemicals

Common Name	Scientific Name	Mesa County	Colorado State List (CDA)	Occurrence in Project Area
Jointed goatgrass	<i>Aegilops cylindrica</i>	G	B	X
Leafy spurge	<i>Euphorbia esula</i>	A	B	
Mayweed chamomile	<i>Anthemis cotula</i>		B	
Meadow knapweed	<i>Centaurea nigrescens</i>	Not known in county	A	
Mediterranean sage	<i>Salvia aethiopsis</i>	Not known in county	A	
Medusahead	<i>Taeniatherum caput-medusae</i>	Not known in county	A	
Moth mullein	<i>Verbascum blattaria</i>		B	
Musk thistle	<i>Carduus nutans</i>	B	B	
Myrtle spurge	<i>Euphorbia myrsinites</i>	A	A	
Orange hawkweed	<i>Hieracium aurantiacum</i>	Not known in county	A	
Oxeye daisy	<i>Chrysanthemum leucanthemum</i>	B	B	
Parrotfeather	<i>Myriophyllum aquaticum</i>	Not known in county	A	
Perennial pepperweed	<i>Lepidium latifolium</i>	B	B	
Perennial sowthistle	<i>Sonchus arvensis</i>		C	
Plumeless thistle	<i>Carduus acanthoides</i>	A	B	
Poison hemlock	<i>Conium maculatum</i>		C	
Puncturevine	<i>Tribulus terrestris</i>	B	C	
Purple loosestrife	<i>Lythrum salicaria</i>	A	A	
Quackgrass	<i>Elymus repens</i>		C	
Redstem filaree	<i>Erodium cicutarium</i>		C	X
Rush skeletonweed	<i>Chondrilla juncea</i>	Not known in county	A	
Russian knapweed	<i>Acroptilon repens</i>	B	B	
Russian olive	<i>Elaeagnus angustifolia</i>	G	B	
Salt cedar (2 species)	<i>Tamarix chinensis</i> <i>Tamarix ramosissima</i>	B	B	X
Scentless chamomile	<i>Tripleurospermum perforata</i>		B	
Scotch thistle	<i>Onopordum acanthium</i> , <i>O. tauricum</i>	B	B	
Spotted knapweed	<i>Centaurea stoebe</i> ssp. <i>micranthos</i>	A	B	
Spotted x diffuse knapweed hybrid	<i>Centaurea x psammogena</i> = <i>C. stoebe</i> x <i>C. diffusa</i>	A	B	
Squarrose knapweed	<i>Centaurea virgata</i>	Not known in county	A	
Sulfur cinquefoil	<i>Potentilla recta</i>	A	B	
Tansy ragwort	<i>Senecio jacobaea</i>	Not known in county	A	
Velvetleaf	<i>Abutilon theophrasti</i>		C	
Wild caraway	<i>Carum carvi</i>		B	
Wild proso millet	<i>Panicum miliaceum</i>		C	
Yellow nutsedge	<i>Cyperus esculentus</i>		B	
Yellow starthistle	<i>Centaurea solstitialis</i>	A	A	
Yellow toadflax	<i>Linaria vulgaris</i>	A	B	
Yellow x Dalmatian toadflax hybrid	<i>Linaria vulgaris</i> x <i>L. dalmatica</i>		B	
Common reed	<i>Phragmites australis</i>	Watch		
Syrian bean caper	<i>Zygophyllum fabago</i>	Watch		
Yellow flag iris	<i>Iris psuedacorus</i>	Watch		

Sources and notes: Colorado Department of Agriculture (CDA) 2020; Mesa County 2020. CDA List "A" Species in Colorado are designated by the Commissioner for eradication. List "B" Species are species for which the Commissioner, in consultation with the state noxious weed advisory committee, local governments, and other interested parties, develops and implements state noxious weed management plans designed to stop the continued spread of these species. List "C" Species are species for which the Commissioner, in consultation with the state noxious weed advisory committee, local governments, and other interested parties, will develop and implement state noxious weed management plans designed to support the efforts of local governing bodies to facilitate more effective

On public lands, the City will conform to the GJFO BLM Standard Mitigation and BLM ROW stipulations for the ROW. The City will conduct maintenance and monitoring in accordance with the Grand Junction BLM ROW stipulations in the land use authorization. Other lands are owned by the City. The City has requested a 35-foot-wide, 30-year ROW for the trail. The City has requested a 40-foot-wide temporary ROW for construction. For areas within 100 feet of the centerline for the concrete dual-flood phase box culvert on BLM-managed lands, the City has requested a 50-foot temporary and permanent ROW to allow for construction and maintenance (see Table 5).

Table 5. ROW lengths on Private and BLM-managed Lands.

ROW type	ROW width	ROW length	Ownership
Paved trail, no CHC*	40-foot temporary, 35-foot permanent	1,024	BLM
Paved trail, no CHC	40-foot temporary, 35-foot permanent	6,186	Private
Paved trail, CHC	22-foot temporary and permanent	401	BLM
Paved trail, CHC	22-foot temporary and permanent	1,136	Private
Paved trail, culvert	50-foot temporary and permanent	200	BLM
Paved trail, culvert	50-foot temporary and permanent	200	Private

Note: lengths vary slightly compared to previous totals provided in Section 2.1.1 due to rounding. *CHC = Colorado hookless cactus.

6.1 Trail Right-of-Way

The City has requested a 35-foot-wide, 30-year ROW for the trail.

6.2 Temporary Use Areas

The City has requested a 40-foot-wide temporary ROW for construction.

7.0 Design Features

Ninety-day notice is required for maintenance activities except where there are rare plant populations; in those cases, the BLM requires notice during the March preceding any work to be done.

The City will contact the BLM as soon as possible upon mobilization to complete emergency repairs. The City will provide the BLM with a list of structures and activities to be completed, disturbance limits, access routes to be used, and timeframe for implementation.

Endangered Species Act: The threatened species CHC (*Sclerocactus glaucus*) has occurrences in the project area. Table 6 lists recommendations with regard to this species.

Table 6. Design features specific to protecting CHC in the project area.

Potential Impact	Design Feature	Notes/Additional Description
Soil compaction	Revegetation measures; biological monitor	<ul style="list-style-type: none"> The disturbance width along the trail will be confined to 22 feet in areas where CHC is located. Construction equipment including concrete trucks will use the trail corridor as a travelway during construction. All new soil-disturbing activities will be more than 20 meters from current occupied CHC locations.* Use of an access route during construction will not result in new disturbance to two CHC individuals located 18 meters from the route due to topography and existing disturbance/access use.
Accidental crushing	Biological monitor; flagging/marketing during construction; workforce education	<ul style="list-style-type: none"> A biological monitor will provide an educational session with contractors and be on-site when work is being conducted in sensitive areas. The biological monitor will ensure compliance with specific protection measures (e.g., install protective boulders) and/or short-term protection during construction (flagging, cones, barrier fencing, or other methods) coordinated with the BLM. Activities will remain on existing designated impact areas. Vehicles will not deviate from the existing authorized access roads or the trail construction corridor. Surface disturbance and the number of vehicles accessing the sensitive area will be minimized.
Increased soil erosion	Revegetation measures; stormwater management plan and measures	<ul style="list-style-type: none"> Silt logs and other measures will be implemented during construction for control of soil erosion and stormwater management. Trail design incorporates erosion control and stormwater management.
Use of herbicides and pesticides	All weed management will be per the BLM GJFO Integrated Weed Management Plan	<ul style="list-style-type: none"> No infestations of noxious weeds requiring management were documented in sensitive areas during plant surveys. Jointed goatgrass was observed near the north end of the Monument Trail, and tamarisk was observed in the wash. Management of these weed infestations would not affect CHC populations. Measures to control the spread of weeds will be conducted per the requirements in the BLM GJFO Integrated Weed Management Plan (BLM 2017).
Dust	Biological monitor; dust suppression; restriction of activities in sensitive areas to outside of blooming seasons	<ul style="list-style-type: none"> Dust-suppression measures will be used to control fugitive dust from access routes and areas of disturbance in the vicinity of the trail alignment. All new soil-disturbing activities will be more than 20 meters from current occupied CHC locations (mentioned previously).* Construction activities will occur outside of the blooming season (April 1 to May 30) to minimize impacts on pollination/pollinators.
Noxious weeds	Clean tools and equipment used for trail construction; monitoring, then spraying and reseeding with native seed mix	<ul style="list-style-type: none"> Soil disturbance may increase the spread of noxious weeds. Jointed goatgrass has been documented in the project area and could be spread by construction; tamarisk infestations are not anticipated to increase due to the project. Measures to control the spread of weeds will be conducted per the requirements in the BLM GJFO Integrated Weed Management Plan (BLM 2017) (mentioned previously).*

9.2 Work Schedule

The normal work schedule will be weekdays (Monday through Friday), approximately from 8am to 5pm. Emergency situations may result in activities outside the normal work schedule. Work will be completed when weather permits year-round but normally will occur between March and October. Exceptions will be in areas with seasonal restrictions identified by the BLM. In case of emergencies, work will be completed as soon as conditions allow.

9.3 Fire Control

Spark arresters are required for equipment generating sparks, including ATVs and chainsaws. No smoking will be allowed during construction activities. Common-sense practices regarding heat/spark sources, particularly in dry conditions, should be followed. Avoiding parking hot vehicles on dry shrubs and other logical avoidance practices will be followed (also see stipulations in Table 6).

9.4 Notification of BLM

The City will notify the BLM and appropriate landowners regarding the schedule and scope of work for construction of the trail as well as for future major maintenance activities. A preconstruction meeting will be held with the City, its contractors, environmental monitors, and agency representatives to review environmental and land use compliance for the project.

Ninety-day notice is required for maintenance activities except where there are rare plant populations; in those cases, the BLM requires notice during the March preceding any work to be done.

9.5 Emergencies

The City will contact the BLM as soon as possible upon mobilization to complete emergency repairs. The City will provide the BLM with a list of structures and activities to be completed, disturbance limits, access routes to be used, and timeframe for implementation.

Emergency access will be allowed during any time of the year. In the event of an emergency, the City and its contractor(s) will notify the BLM as soon as possible but no later than 24 hours. The City will meet with the BLM on-site after an emergency to determine the required rehabilitation work and to establish a rehabilitation schedule.

If emergency access to the trail is required during wet weather, or if other maintenance activities result in the removal of vegetation or substantial vehicle impacts on existing native vegetation, revegetation of disturbed areas will be completed as directed by the BLM. Reclamation and revegetation will be implemented, as required, as soon as practical after any emergency road access or maintenance work needed to repair the trail.

If emergency maintenance is required during the winter or spring months, care will be taken to minimize erosion and sedimentation to the extent practicable, and effects will be mitigated

APPENDIX A
Typical Details and Roll Plot

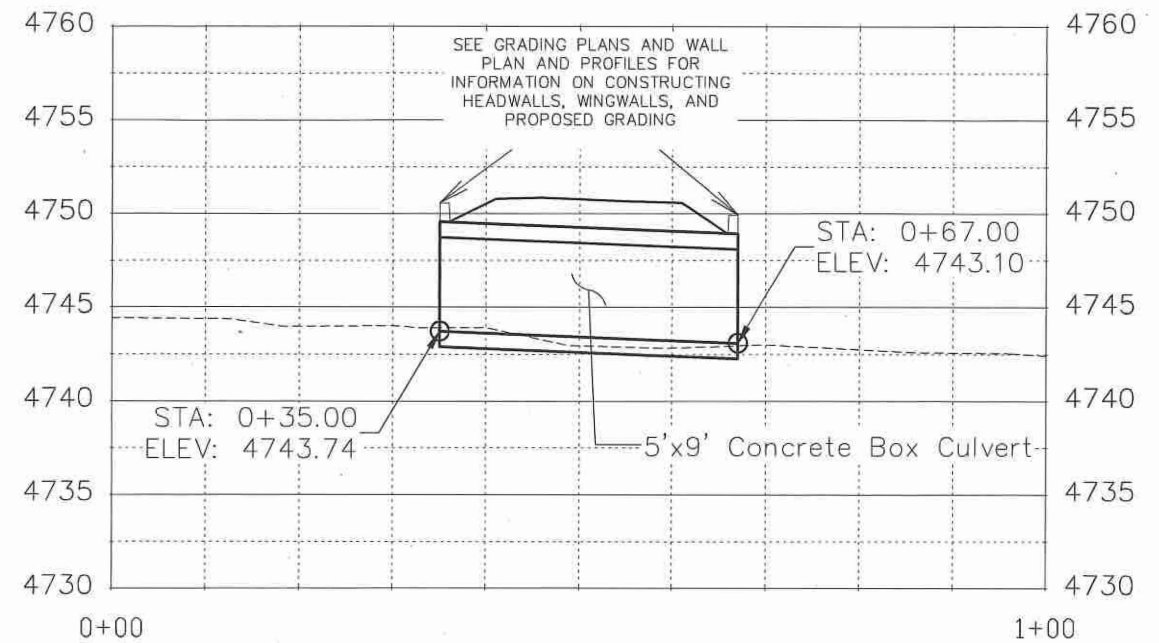
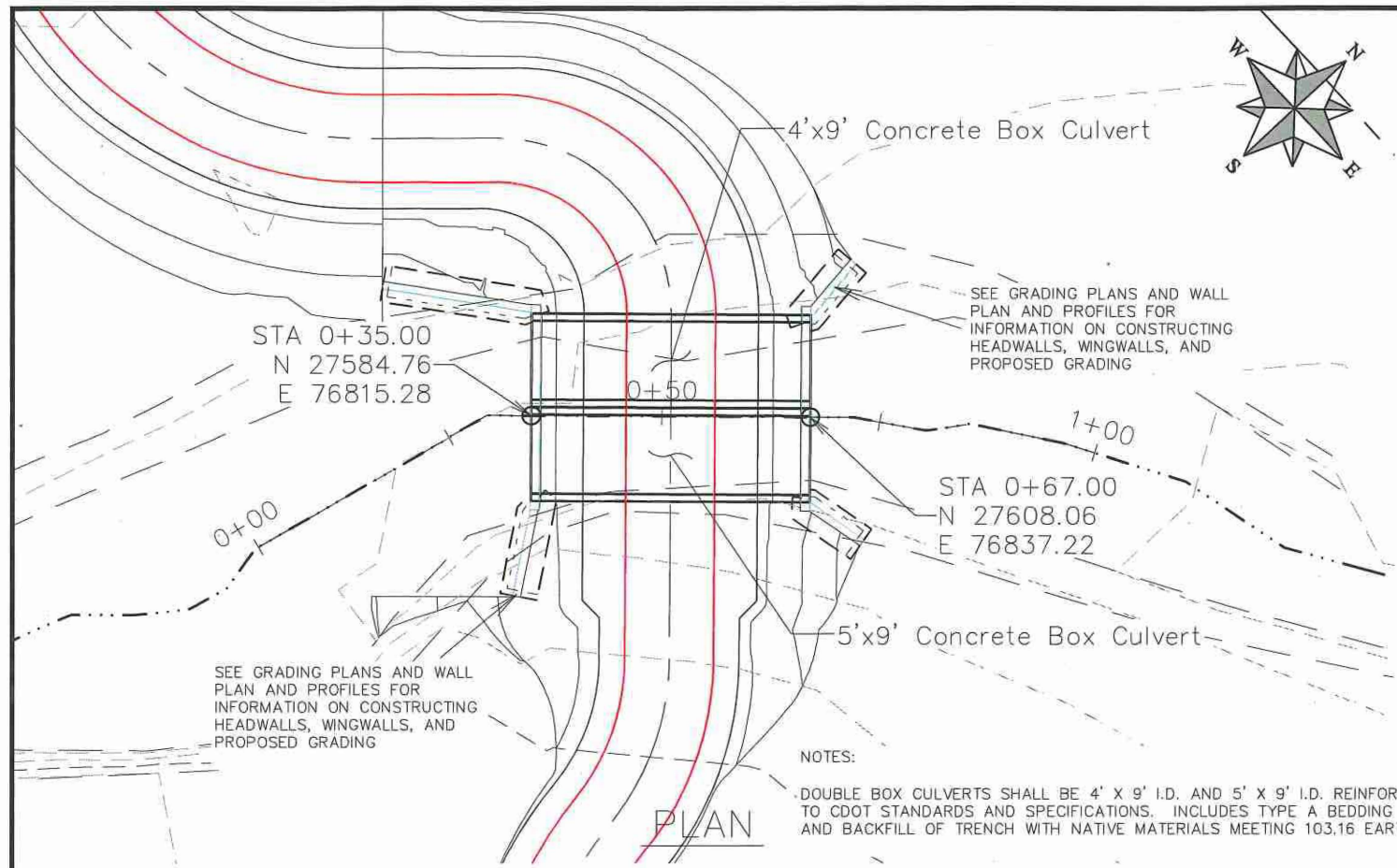

PROFILE

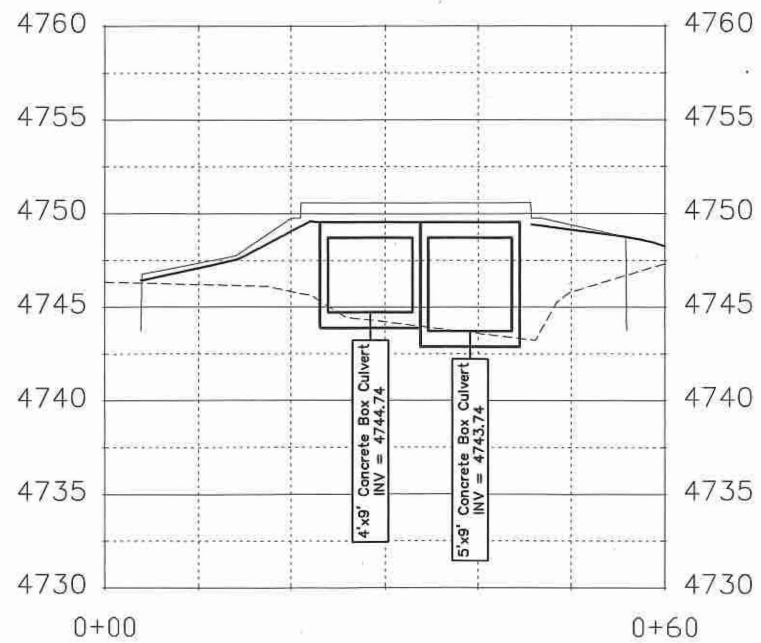

UPSTREAM CROSS SECTION

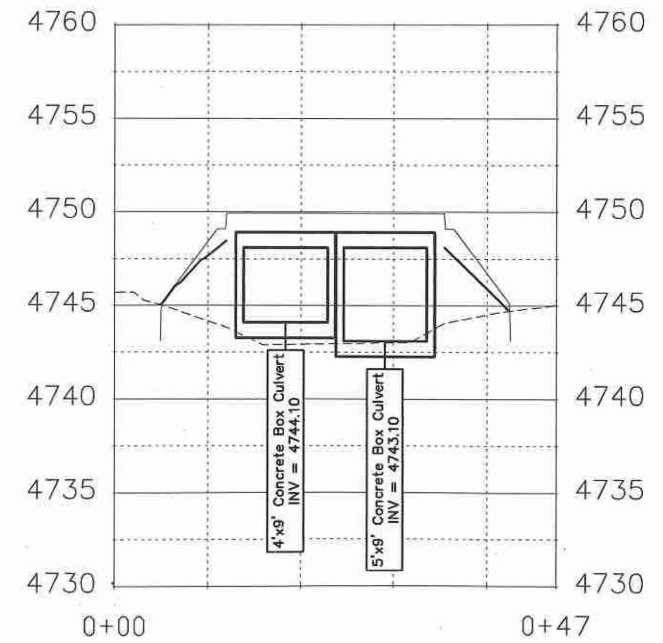

DOWNSTREAM CROSS SECTION

REVISION	DESCRIPTION	DATE	DRAWN BY	HMC	DATE	2023	DESIGNED BY	KA	DATE	2023	CHECKED BY	KA	DATE	2023	APPROVED BY	KA	DATE	2023
REVISION																		
REVISION																		
REVISION																		

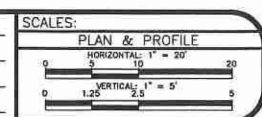

PUBLIC WORKS
ENGINEERING DIVISION
PROJECT NO. G2208

MONUMENT CONNECT PHASE 2
BOX CULVERT PLAN & PROFILE - 1
November 8, 2023

B1

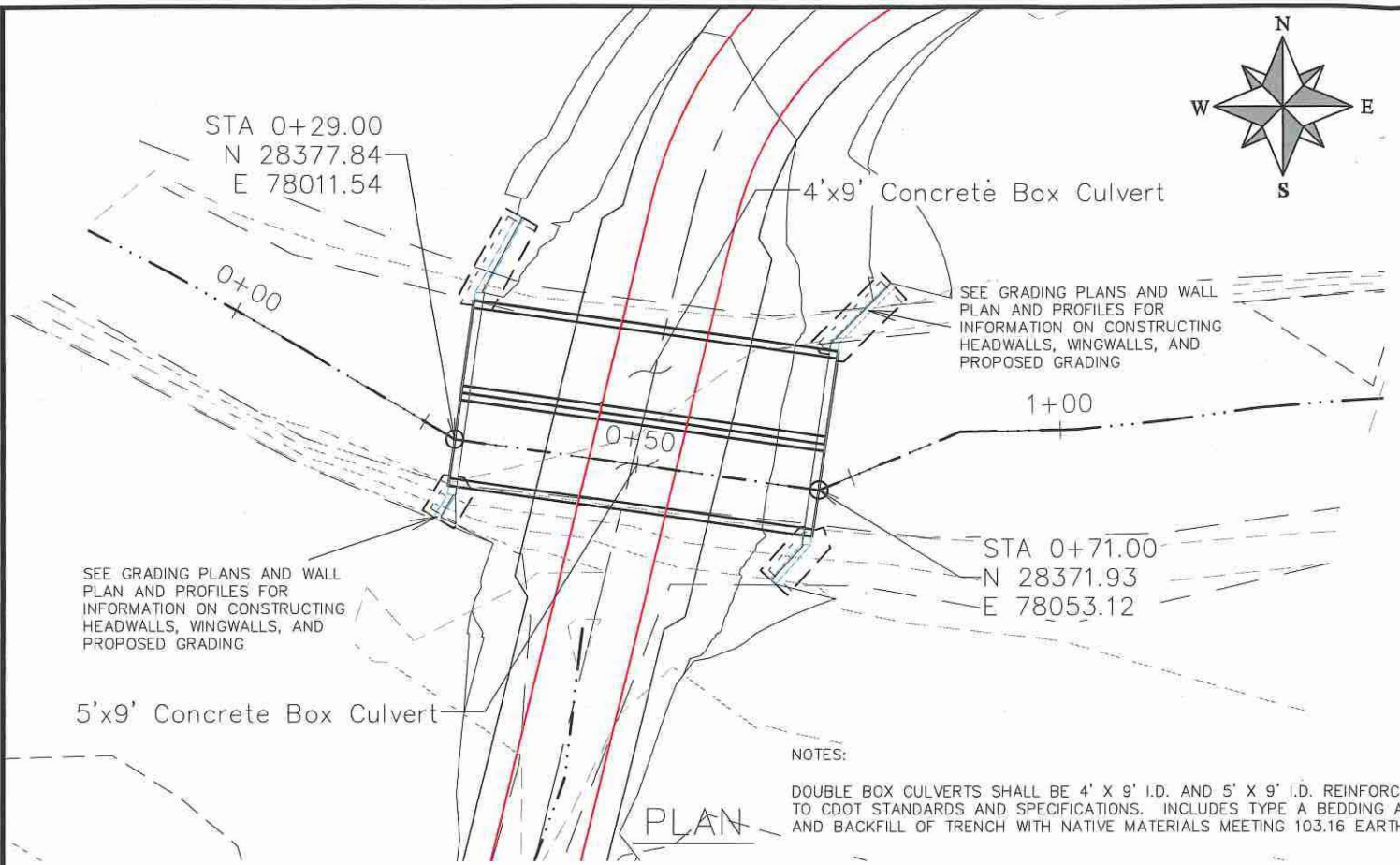

NOTES:
 DOUBLE BOX CULVERTS SHALL BE 4' X 9' I.D. AND 5' X 9' I.D. REINFORCED CONCRETE CONFORMING TO CDOT STANDARDS AND SPECIFICATIONS. INCLUDES TYPE A BEDDING AND HAUNCHING MATERIAL AND BACKFILL OF TRENCH WITH NATIVE MATERIALS MEETING 103.16 EARTH BACKFILL MATERIAL.

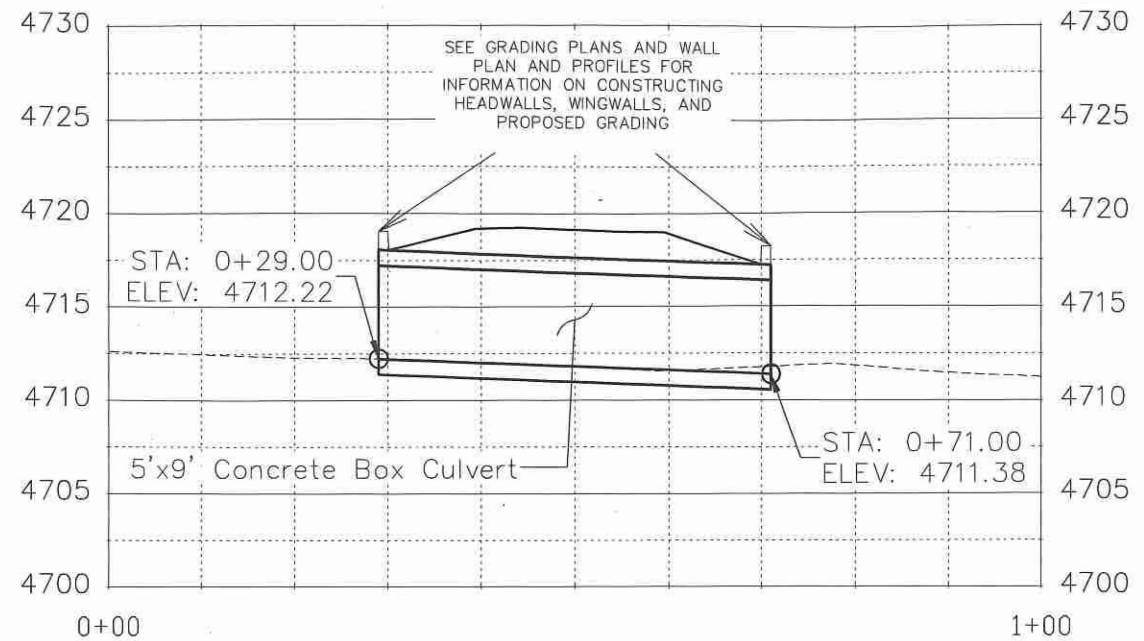

PROFILE

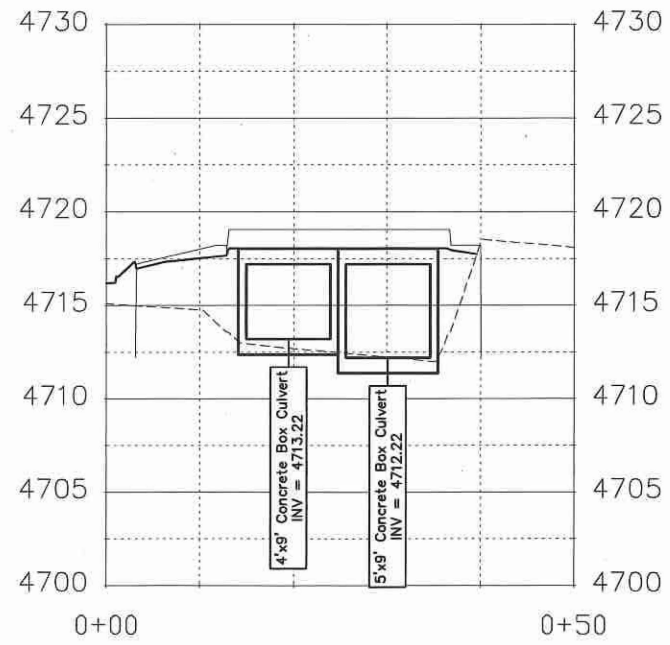

UPSTREAM CROSS SECTION

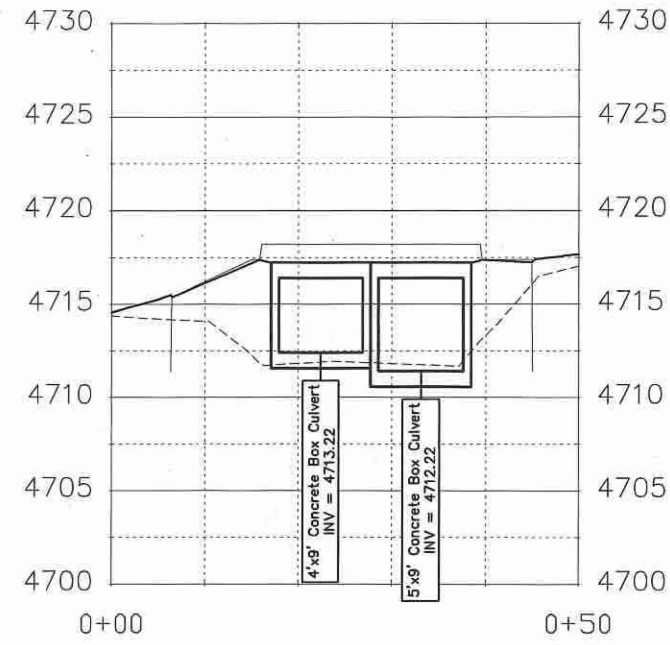

DOWNSTREAM CROSS SECTION

REVISION	DESCRIPTION	DATE	DRAWN BY	HMC	DATE	2023
REVISION			DESIGNED BY	KA	DATE	2023
REVISION			CHECKED BY	KA	DATE	2023
REVISION			APPROVED BY	KA	DATE	2023

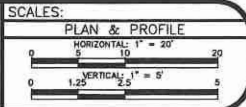

PUBLIC WORKS
 ENGINEERING DIVISION
 PROJECT NO. G2208

MONUMENT CONNECT PHASE 2
 BOX CULVERT PLAN & PROFILE - 2
 November 8, 2023

B2

MONUMENT CORRIDOR SHARED-USE-PATH PHASE 2 ALIGNMENT 3/13/2023



APPENDIX B

**Design Features and BMP's Committed to by the City of Grand
Junction**

The following are applicant-committed design features.

General/Notification

M&E-14: A pre-construction meeting will be held with the BLM before and to facilitate implementation of plans and ensure compliance with stipulations or conditions of approval. The BLM will be notified at least 48 hours prior to construction or reclamation work. 90-day notice is required for any maintenance activities, except where there are rare plant populations; in those cases, BLM requires additional 90-days' notice no later than the March preceding any work to be done.

R-11: Project design should take into consideration any existing vegetation surrounding the project that can be used for visual screening. Care should be taken to preserve the integrity of the vegetation and the vegetation should remain standing and undamaged when the cut-and-fill slopes are recontoured.

A-10: Improve engine technology (Tier 2 or better) for all mobile and non-road diesel engines to reduce NOx, PM, CO, and VOC emissions.

A-24: Utilize dust suppression techniques on unpaved surfaces including watering, chemical suppressants, and gravel.

A-30: Reduce unnecessary vehicle idling to reduce combustion emissions, ozone formation, visibility impacts, and fuel consumption.

A-32: Restrict surface disturbing activities to periods when wind speeds are less than 25 mph.

S-17: Native vegetation and soils will be protected and disturbance to them will be minimized.

H-6: Before activities take place, every pad, access road, or facility site will have an approved surface drainage plan for establishing positive management of surface water drainage, to reduce erosion and sediment transport. The drainage plan will include adaptive BMPs, monitoring, maintenance and reporting. BMPs may include run-on/run-off controls such as surface pocking

with weeds. Seeds and plant parts shall be collected and incinerated when possible.

WEED-26: When seeding has been specified for construction and maintenance activities, seed all disturbed soil (except travel route) soon after work is completed.

WEED-27: Use a certified weed-free seed mix suitable for local environmental conditions that includes fast, early growing (preferably native) species to provide quick revegetation. Consider applying weed-free mulch with seeding. (SOP)

WEED-28: Periodically inspect roads and rights-of-way for noxious weeds. Train staff to recognize weeds and report locations to the local weed specialist. Follow-up with treatment when needed.

WEED-29: When reclaiming roads, treat weeds before roads are made impassable. Inspect and follow up based on initial inspection and documentation.

WEED-30: To avoid weed infestations, create and maintain healthy plant communities whenever possible, including utility rights-of-ways, roadsides, scenic overlooks, trailheads, and campgrounds.

CR-4: The National Historic Preservation Act, as amended, requires that if newly discovered historic or archaeological materials or other cultural resources are identified during project implementation, work in that area must stop and the BLM Authorized Officer must be notified immediately. Within five working days the BLM Authorized Officer will inform the proponent as to: a) Whether the materials appear eligible for the National Register of Historic Places; b) The mitigation measures the proponent will likely have to undertake before the site could be used (assuming in situ preservation is not practicable), (36 CFR 800.13); and c) A timeframe for the BLM Authorized Officer to complete an expedited review under 36 CFR 800.11 to confirm, through the State Historic Preservation Office, that the BLM Authorized Officer's findings were correct and mitigation was appropriate.

S-2: When saturated soil conditions existing on access roads or location, or when road rutting becomes deeper than 3 inches, construction shall be halted until soil material dries out or is frozen sufficiently for construction to proceed without undue damage and erosion to soils, roads and locations.

- The City will monitor for the presence of noxious weeds and treat noxious weeds in coordination with BLM
- The BLM and City will coordinate to close and potentially rehabilitate social trails near CHC.
- The City will coordinate with the BLM for needed trail maintenance on BLM-managed lands.

Long-term maintenance of the Monument Trail will be performed by the City throughout the life of the trail system. Maintenance will include repair of erosion-control features, culverts, noxious weed treatments, and trail clearing as needed.

CHC normally blooms in April through May, and populations fluctuate over time, requiring new surveys to determine appropriate avoidance activities. Any future construction or maintenance work on the Monument Trail will be coordinated with BLM ecologists, who will determine the extent of monitoring and survey that is required. The BLM will be notified in the fall prior to any planned maintenance work so that spring surveys can take place for CHC in the project area. Only ground-disturbing activities will require BLM coordination.

Paleontological Resources

PR-1 Culvert installation in PYFC 4/5 level areas of the Morrison Formation, Summerville Formation, or Entrada Sandstone. The Unanticipated Discovery Plan below outlines procedures to follow in the event that paleontological resources are encountered during ground-disturbing and other construction activities in the absence of a paleontological resources monitor:

1. Upon discovery/excavation of significant paleontological resources, immediately stop construction activities and inform the on-site construction foreman/supervisor of discovery. Do not attempt to remove the fossils.
2. The construction foreman/supervisor should contact the appropriate personnel (BLM, City, etc.) immediately and notify them of the discovery.
3. A salvage/recovery plan should be formulated with help of a BLM-permitted paleontologist. Construction activities in the area of discovery

APPENDIX C
Herbicides Approved for Use on BLM Lands

ACTIVE			EPA REG.
INGREDIENT	TRADE NAME	MANUFACTURER	NUMBER
Chlorsulfuron	Alligare Chlorsulfuron 75	Alligare, LLC	81927-43
	Chlorsulfuron E-Pro 75 WDG	Nufarm Americas Inc.	79676-72
	Nufarm Chlorsulf SPC 75 WDG Herbicide	Nufarm Americas Inc.	228-672
	Telar XP	Bayer Environmental Science	432-1561
	Telar XP	DuPont Crop Protection	352-654
Clopyralid	Alligare Clopyralid 3	Alligare, LLC	81927-14
	CleanSlate	Nufarm Americas Inc.	228-491
	Pyramid R&P	Albaugh, LLC (Albaugh, Inc/Agri Star)	42750-94
	Reclaim	Dow AgroSciences	62719-83
	Spur	Albaugh, LLC (Albaugh, Inc/Agri Star)	42750-89
	Stinger	Dow AgroSciences	62719-73
	Transline	Dow AgroSciences	62719-259
Clopyralid + 2, 4-D	Alligare Cody Herbicide	Alligare, LLC	81927-28
	Commando	Albaugh, LLC (Albaugh, Inc/Agri Star)	42750-92
	Curtail	Dow AgroSciences	62719-48
	Cutback	Nufarm Americas Inc.	71368-72
2, 4-D	2,4-D 4# Amine Weed Killer	UAP-Platte Chem. Co.	34704-120
	2,4-D Amine	Helena Agri-Enterprises, LLC (Helena Chemical Company)	5905-72
	2,4-D Amine 4	Albaugh, LLC (Albaugh, Inc/Agri Star)	42750-19
	2,4-D Amine 4	Helena Agri-Enterprises, LLC (Helena Chemical Company)	42750-19-5905
	2,4-D LV 4	Albaugh, LLC (Albaugh, Inc/Agri Star)	42750-15
	2,4-D LV 6 Ester	Nufarm Americas Inc.	228-95
	2,4-D LV4	Helena Agri-Enterprises, LLC (Helena Chemical Company)	5905-90
	2,4-D LV 6	Albaugh, LLC (Albaugh, Inc/Agri Star)	42750-20
	2,4-D LV6	Helena Agri-Enterprises, LLC (Helena Chemical Company)	42750-20-5905
	2,4-D LV6	Helena Agri-Enterprises, LLC (Helena Chemical Company)	5905-93
	Alliagre 2,4-D Amine	Alligare, LLC	81927-38
	Alligare 2,4-D LV 6	Alligare, LLC	81927-39
	Aqua-Kleen	Nufarm Americas Inc.	71368-4
	Aqua-Kleen	Nufarm Americas Inc.	228-378
	Barrage HF	Helena Agri-Enterprises, LLC (Helena Chemical Company)	5905-529
	Barrage LV Ester	Helena Agri-Enterprises, LLC (Helena Chemical Company)	5905-504
	Base Camp Amine 4	Wilbur-Ellis Co., LLC (Wilbur-Ellis Co.)	71368-1-2935
	Base Camp LV6	Wilbur-Ellis Co., LLC (Wilbur-Ellis Co.)	2935-553
	Broadrange 55	Wilbur-Ellis Co., LLC (Wilbur-Ellis Co.)	2217-813-2935

ACTIVE			EPA REG.
INGREDIENT	TRADE NAME	MANUFACTURER	NUMBER
Dicamba - continued	Kam-Ba	Drexel Chemical Company	19713-624
	Rifle	Loveland Products Inc.	34704-861
	Sterling Blue	WinField-United (WinField Solutions, LLC)	7969-137-1381
	Topeka	Rotam North America, Inc.	83100-34-83979
	Vanquish	Syngenta	100-884
	Vanquish Herbicide	Nufarm Americas Inc.	228-397
	Vision	Helena Agri-Enterprises, LLC (Helena Chemical Company)	5905-576
Dicamba + 2, 4-D	Alligare Dicamba + 2,4-D DMA	Alligare, LLC	81927-42
	Brash	WinField-United (WinField Solutions, LLC)	1381-202
	Brush-Rhap	Helena Agri-Enterprises, LLC (Helena Chemical Company)	5905-568
	Cimarron MAX - Part B	Bayer Environmental Science	432-1555
	Cimarron MAX - Part B	DuPont Crop Protection	352-615
	KambaMaster	Nufarm Americas Inc.	71368-34
	Latigo	Helena Agri-Enterprises, LLC (Helena Chemical Company)	5905-564
	Outlaw	Helena Agri-Enterprises, LLC (Helena Chemical Company)	5905-574
	Range Star	Albaugh, LLC (Albaugh, Inc/Agri Star)	42750-55
	Rifle-D	Loveland Products Inc.	34704-869
	Veteran 720	Nufarm Americas Inc.	228-295
	Weedmaster	Nufarm Americas Inc.	71368-34
	Dicamba + Diflufenzopyr	Distinct	BASF Corporation
Overdrive		BASF Corporation	7969-150
NOTE: In accordance with the Record of Decision for the <i>Vegetation Treatments Using Herbicides on Bureau of Land Management Lands in 17 Western States Programmatic Environmental Impact Statement (PEIS)</i>, the aerial application of this herbicide is prohibited.			
Diquat	Alligare Diquat Herbicide	Alligare, LLC	81927-43
	Diquat E-AG 2L	Nufarm Americas Inc.	79676-75
	Diquat E-Pro 2L	Nufarm Americas Inc.	79676-75
	Diquat SPC 2L Herbicide	Nufarm Americas Inc.	228-675
	Nufarm Diquat 2L Herbicide	Nufarm Americas Inc.	228-675
	Reward	Syngenta Professional Products	100-1091
Diuron	Alligare Diuron 4L	Alligare, LLC	81927-44
	Alligare Diuron 80DF	Alligare, LLC	81927-12
	Ceannard Diuron 80DF	Ceannard, Inc.	58035-16
	Direx 4L	DuPont Crop Protection	352-678
	Direx 4L	Makhteshim Agan of N. A. (ADAMA)	66222-54
	Diuron 4L	Drexel Chemical Company	19713-36

ACTIVE			EPA REG.
INGREDIENT	TRADE NAME	MANUFACTURER	NUMBER
Glyphosate - continued	Aqua Star	Albaugh, LLC (Albuagh, Inc/Agri Star)	42750-59
	Aquamaster	Monsanto	524-343
	AquaPro Aquatic Herbicide	SePRO Corporation	62719-324-67690
	Buccaneer	Tenkoz	55467-10
	Buccaneer Plus	Tenkoz	55467-9
	Credit Xtreme	Nufarm Americas Inc.	71368-81
	Foresters	Nufarm Americas Inc.	228-381
	Gly Star Gold	Albaugh, LLC (Albuagh, Inc/Agri Star)	42750-61
	Gly Star Original	Albaugh, LLC (Albuagh, Inc/Agri Star)	42750-60
	Gly Star Plus	Albaugh, LLC (Albuagh, Inc/Agri Star)	42750-61
	Gly Star Pro	Albaugh, LLC (Albuagh, Inc/Agri Star)	42750-61
	Gly-4	Universal Crop Protection Alliance	42750-60-72693
	Gly-4 Plus	Universal Crop Protection Alliance	72693-1
	Gly-4 Plus	Universal Crop Protection Alliance	42750-61-72693
	GlyphoMate 41	PBI/Gordon Corporation	2217-847
	Glypro	Dow AgroSciences	62719-324
	Glypro Plus	Dow AgroSciences	62719-322
	Honcho	Monsanto	524-445
	Honcho Plus	Monsanto	524-454
	Imitator Aquatic	Drexel Chemical Company	19713-623
	Imitator DA	Drexel Chemical Company	19713-586
	Imitator Plus	Drexel Chemical Company	19713-526
	KleenUp Pro	Loveland Products, Inc.	34704-890
	Mad Dog Plus	Loveland Products, Inc.	34704-890
	Makaze	Loveland Products, Inc.	34704-890
	Mirage	Loveland Products Inc.	34704-889
	Mirage Herbicide	UAP-Platte Chem. Co.	524-445-34704
	Mirage Plus	Loveland Products Inc.	34704-890
	Rattler	Helena Agri-Enterprises, LLC (Helena Chemical Company)	524-445-5905
	Razor	Nufarm Americas Inc.	228-366
	Razor Pro	Nufarm Americas Inc.	228-366
	Rodeo	Dow AgroSciences	62719-324
	Roundup Custom	Monsanto	524-343
	Roundup Original	Monsanto	524-445
	Roundup Original II	Monsanto	524-454
	Roundup Original II CA	Monsanto	524-475
	Roundup PROMAX	Monsanto	524-579
	Roundup PRO	Monsanto	524-475
	Roundup PRO Concentrate	Monsanto	524-529
	Roundup PRO Dry	Monsanto	524-505
Showdown	Helena Agri-Enterprises, LLC (Helena Chemical Company)	71368-25-5905	

ACTIVE			EPA REG.
INGREDIENT	TRADE NAME	MANUFACTURER	NUMBER
Imazapyr - continued	Polaris AQ	Nufarm Americas Inc.	241-426-228
	Polaris Herbicide	Nufarm Americas Inc.	241-346-228
	Polaris RR	Nufarm Americas Inc.	241-273-228
	Polaris SP	Nufarm Americas Inc.	228-536
	Polaris SP	Nufarm Americas Inc.	241-296-228
	SSI Maxim Arsenal 0.5G	SSI Maxim Co., Inc.	34913-23
	SSI Maxim Arsenal 5.0 G	SSI Maxim Co., Inc.	34913-24
	Stalker	BASF Corporation	241-398
Imazapyr + Diuron	Alligare Mojave 70 EG	Alligare, LLC	81927-25
	Imazuron	Nufarm Americas Inc.	228-654
	Sahara DG	BASF Corporation	241-372
	SSI Maxim Topsite 2.5G	SSI Maxim Co., Inc.	34913-22
Imazapyr + Metsulfuron methyl	Lineage Clearstand	Bayer Environmental Science	432-1578
	Lineage Clearstand	DuPont Crop Protection	352-766
Imazapyr + Sulfometuron methyl + Metsulfuron methyl	Lineage HWC	Bayer Environmental Science	432-1577
	Lineage HWC	DuPont Crop Protection	352-765
	Lineage Prep	Bayer Environmental Science	432-1579
	Lineage Prep	DuPont Crop Protection	352-767
NOTE: In accordance with the Record of Decision for the <i>Vegetation Treatments Using Herbicides on Bureau of Land Management Lands in 17 Western States Programmatic Environmental Impact Statement (PEIS)</i>, the aerial application of this herbicide is prohibited.			
Metsulfuron methyl	Alligare MSM 60	Alligare, LLC	81927-7
	AmTide MSM 60DF Herbicide	AmTide, LLC	83851-3
	Cimarron MAX - Part A	Bayer Environmental Science	432-1555
	Cimarron MAX - Part A	DuPont Crop Protection	352-615
	Escort XP	Bayer Environmental Science	432-1549
	Escort XP	DuPont Crop Protection	352-439
	Patriot	Nufarm Americas Inc.	228-391
	PureStand	Nufarm Americas Inc.	71368-38
	Rometsol	Rotam North America, Inc.	831000-2-83979
Metsulfuron methyl + Chlorsulfuron	Cimarron Plus	Bayer Environmental Science	432-1572
	Cimarron Plus	DuPont Crop Protection	352-670
	Cimarron X-tra	DuPont Crop Protection	352-669
Picloram	Alligare Picloram 22K	Alligare, LLC	81927-18
	Grazon PC	Dow AgroSciences	62719-181
	OutPost 22K	Dow AgroSciences	62719-6
	Tordon 22K	Dow AgroSciences	62719-6
	Tordon K	Dow AgroSciences	62719-17

ACTIVE			EPA REG.
INGREDIENT	TRADE NAME	MANUFACTURER	NUMBER
Sulfometuron methyl + Metsulfuron methyl	Alligare SFM Extra	Alligare, LLC	81927-5
	Oust Extra	Bayer Environmental Science	432-1557
	Oust Extra	DuPont Crop Protection	352-622
	Spyder Extra Selective	Nufarm Americas Inc.	228-690
<p>NOTE: In accordance with the Record of Decision for the <i>Vegetation Treatments Using Herbicides on Bureau of Land Management Lands in 17 Western States Programmatic Environmental Impact Statement (PEIS)</i>, the aerial application of this herbicide is prohibited.</p>			
Tebuthiuron	Alligare Tebuthiuron 20 P	Alligare, LLC	81927-41
	Alligare Tebuthiuron 80 WG	Alligare, LLC	81927-37
	Spike 20P	Dow AgroSciences	62719-121
	Spike 80DF	Dow AgroSciences	62719-107
	SpraKil S-5 Granules	SSI Maxim Co., Inc.	34913-10
Tebuthiuron + Diuron	SpraKil SK-13 Granular	SSI Maxim Co., Inc.	34913-15
	SpraKil SK-26 Granular	SSI Maxim Co., Inc.	34913-16
Triclopyr	Alligare Boulder 6.3	Alligare, LLC	81927-54
	Alligare Triclopyr 4	Alligare, LLC	81927-11
	Alligare Triclopyr 3	Alligare, LLC	81927-13
	Element 3A	Dow AgroSciences	62719-37
	Element 4	Dow AgroSciences	62719-40
	Forestry Garlon XRT	Dow AgroSciences	62719-553
	Garlon 3A	Dow AgroSciences	62719-37
	Garlon 4	Dow AgroSciences	62719-40
	Garlon 4 Ultra	Dow AgroSciences	62719-527
	Pathfinder II	Dow AgroSciences	62719-176
	Relegate	Nufarm Americas Inc.	228-521
	Relegate RTU	Nufarm Americas Inc.	228-522
	Remedy	Dow AgroSciences	62719-70
	Remedy Ultra	Dow AgroSciences	62719-552
	Renovate 3	SePRO Corporation	62719-37-67690
	Renovate OTF	SePRO Corporation	67690-42
	Tahoe 3A	Nufarm Americas Inc.	228-520
	Tahoe 4E	Nufarm Americas Inc.	228-385
	Tahoe 4E Herbicide	Nufarm Americas Inc.	228-517
	Triclopyr RTU	Albaugh, LLC (Albaugh, Inc/Agri Star)	42750-173
Trycera	Helena Agri-Enterprises, LLC (Helena Chemical Company)	5906-580	
Vastlan	Dow AgroSciences	62719-687	

THIS PAGE INTENTIONALLY LEFT BLANK