

**GRAND JUNCTION LIQUOR LICENSING AUTHORITY
MINUTES
July 3, 2024**

I. Call to Order

The meeting was called to order at 2:00 p.m. Those present were Hearing Officer Sam D. Starritt, (virtual) City Attorney John Shaver, City Clerk Selestina Sandoval and Deputy City Clerk Krystle Koehler.

II. License Renewal Applications

1. Orange Coast Investments, Inc. dba Grand Vista Hotel, 2790 Crossroads Blvd, Grand Junction, CO 81506, Hotel & Restaurant.
2. The Platinum Cleaver, LLC dba Pantuso's Ristorante, 755 Horizon Drive, Grand Junction, CO 81506, Hotel & Restaurant.

Hearing Officer Starritt read renewals 1 – 2 into the record and there was a correction to The Platinum Cleaver, LLC dba Pantuso's Ristorante address which the correct address is 421 Brach Drive, Grand Junction, CO 81507, Hearing Officer Starritt verified with Mrs. Koehler the applications were in order. Hearing Officer Starritt asked if anyone was present to speak against any of the applications; there was no one.

Renewals 1 – 2 were approved.

III. Special Event Permit Applications

1. Western Slope Center for Children, 2350 G Road, Grand Junction, CO 81505, Sweet Swing Peaches and Baseball Extravaganza - 2024", Located at 1240 Gunnison Ave, Grand Junction, CO 81501 on July 20th 11 a.m. - 4 p.m.

Development Director: Annie Lampard, 2015 North 6th Street, Grand Junction, CO 81501.

Development Director Annie Lampard was present and answered a series of questions regarding the event location, security, and how it will be conducted lawfully. Hearing Officer Starritt verified with Mrs. Koehler the application was in order and asked if there was anyone present to speak against the application. There was no one. Hearing Officer Starritt entered Exhibits "A" and "B" (attached) into the record.

Hearing Officer Starritt found that pursuant to the Colorado State Statue 44-05-106, there are no grounds to deny the special event permit; it would not be injurious to the public welfare because of the nature of the special event, its location within the community, or the failure of the applicant in past special events to conduct the event in compliance with applicable laws. The application for the special event permit submitted by Western Slope Center for Children for “Sweet Swing Peaches and Baseball Extravaganza - 2024” was in order and approved.

2. Rotary Club of Grand Junction – Horizon Sunrise, P.O. Box 459, Grand Junction, CO 81502 “Beer Garden at Market On Main Events - 2024” – August 22, 2024, from 5:00 p.m. to 10:30 p.m. and September 26, 2024, from 5:00 p.m. to 10:30 p.m. located on Main Street between 3rd and 7th Street.

Event Manager: Miquette Gerber, 324 Dakota Dr, Grand Junction, CO 81507.

Event Manager Miquette Gerber was present and answered a series of questions regarding the event location, security, and how it will be conducted lawfully. Hearing Officer Starritt verified with Mrs. Koehler the application was in order and asked if there was anyone present to speak against the application. There was no one. Hearing Officer Starritt entered Exhibits “A”, “B” “C” (attached) into the record.

Hearing Officer Starritt found that pursuant to the Colorado State Statue 44-05-106, there are no grounds to deny the special event permit; it would not be injurious to the public welfare because of the nature of the special event, its location within the community, or the failure of the applicant in past special events to conduct the event in compliance with applicable laws. The application for the special event permit submitted by Rotary Club of Grand Junction – Horizon Sunrise for “Beer Garden at Market on Main Events - 2024” was in order and approved.

IV. Other Business

There was none.

V. Adjournment

The meeting was adjourned at 2:41 p.m.

SPECIAL EVENT PERMIT
QUESTIONNAIRE AND AFFIDAVIT

A

1. Name of Event: " Sweet Swing" Peaches and Baseball Extravaganza

2. How many attendees are expected? 170

3. Has the event been held in the past? If so, how many years? No

4. Have there ever been any violations or citations issued during the event in the past?

No

5. Describe the premises at which the event will take place (attach diagram).

It will be at the practice feilds of Lincoln Park

6. What type of and how many security will be provided?

They will be indivuals who have been trained to check IDs, manage crowds, and control alcohol consumutio

7. Describe the Security Control Plan (use additional sheet if necessary).

There will be 2 people at the liquor booth to check ID' s and mark people whos ID' s have been checked.

There will be 2 people roaming the crowd for alcohol control.

There will be 2 people at the entrance.

There will be 2 people at the exit/parking lot making sure alcohol doesn' t leave the premise.

8. How will security personnel be identified?

They will have shirts marked at such.

9. If this event is an outdoor event, how will the exterior boundaries of the premises be marked (i.e., roped, fenced, etc.)?

The exterior is fenced off.

Hot dogs, hamburgers, peach-themed desserts and refreshments.

A

10. What method of age verification will be used (i.e., at the door, at the bar, etc.) and how will underage patrons be identified so as not to be served alcohol beverages (i.e., stamp or mark on the hand, etc.)?

We will have people checking at the bar and marking the right hand with an X

11. How will the conduct and level of intoxication of attendees be monitored and by whom?

Attendees will not be given more than 2 beverages. This will be enforced by individuals providing the liquor

12. Have the volunteers or members of your organization been trained in the sale/service of alcohol beverages?

Yes

13. What other types of beverages and food/snacks will be available?

There will be water, lemonade. There will be pies, burgers, desserts and other peach themed snacks.

14. Does this organization (applicant) have a State and City Sales Tax Number ? If so, provide those numbers below. If not, what is the application submission date?

98-11791-0000

I hereby certify, under penalty of perjury, that the information provided to the Grand Junction Liquor Licensing Authority contained in this questionnaire/affidavit is true and accurate to the best of my knowledge.

Carrie J. Jaramol

05/22/2024

Applicant's Signature

Date

STATE OF COLORADO)
COUNTY OF MESA) SS.
CITY OF GRAND JUNCTION)

Subscribed and sworn to before me this 28 day of May, 2024.

Witness my hand and official Seal.

Jaime L. Smith

Notary Public

July 22, 2026

My commission expires

JAIME L SMITH
NOTARY PUBLIC
STATE OF COLORADO
NOTARY ID 20144027558
MY COMMISSION EXPIRES JULY 22, 2026

B



blue line is the fenced in area where the liquor will be

SPECIAL EVENT PERMIT
QUESTIONNAIRE AND AFFIDAVIT

A

1. Name of Event: Beer Garden at Market on Main Events 8/22/24 and 9/26/24

2. How many attendees are expected? ~5000

3. Has the event been held in the past? If so, how many years? 1 year

4. Have there ever been any violations or citations issued during the event in the past?
No

5. Describe the premises at which the event will take place (attach diagram).
See attached drawing. Main Street Grand Junction, between 3rd and 7th Streets.

6. What type of and how many security will be provided?
Citadel Security, or another comparable company, will be hired for roaming about the entire area.

7. Describe the Security Control Plan (use additional sheet if necessary).
Every egress point will have signage noting that no alcohol is allowed beyond the physical barrier. - See attached.
At egress points nearest the pouring station at 4th and Main, at least 1 person will be there to not allow
ensure alcohol does not leave the boundary of the beer garden. Volunteers will be checking photo ID for those
those wishing to purchase alcohol. If they provide approved ID, they will be issued a wrist band prior to
being able to purchase alcohol.

8. How will security personnel be identified?
Hired security personnel will have shirts with "security" printed on them.

9. If this event is an outdoor event, how will the exterior boundaries of the premises be marked (i.e., roped, fenced, etc.)?
Pedestrian or other fencing will be used.

A

10. What method of age verification will be used (i.e., at the door, at the bar, etc.) and how will underage patrons be identified so as not to be served alcohol beverages (i.e., stamp or mark on the hand, etc.)?

Valid State or Federal issued forms of identification will be requested from anyone who appears to be 55 years of age. Once a person is verified to be over 21 years of age, they will be issued a wrist band.

11. How will the conduct and level of intoxication of attendees be monitored and by whom?

Shouting loud and/or slurred speech / Instead of/uneven gait and/or standing / In appropriate behavior

12. Have the volunteers or members of your organization been trained in the sale/service of alcohol beverages?

Yes. many of our volunteers have taken the City's Liquor Server Training on multiple occasions.

13. What other types of beverages and food/snacks will be available?

The venue will have food trucks and local restaurants will be open for event attendees

14. Does this organization (applicant) have a State and City Sales Tax Number ? If so, provide those numbers below. If not, what is the application submission date?

84-1499826

I hereby certify, under penalty of perjury, that the information provided to the Grand Junction Liquor Licensing Authority contained in this questionnaire/affidavit is true and accurate to the best of my knowledge.

Luiguelto Gerber

Applicant's Signature

6/4/24

Date

STATE OF COLORADO)
COUNTY OF MESA) SS.
CITY OF GRAND JUNCTION)

Subscribed and sworn to before me this 4th day of June, 20 24.

Witness my hand and official Seal.



Notary Public

01-29-2027

My commission expires

ETHAN CHARLES DISHAW
NOTARY PUBLIC
STATE OF COLORADO
NOTARY ID 20194003931
MY COMMISSION EXPIRES JANUARY 29, 2027

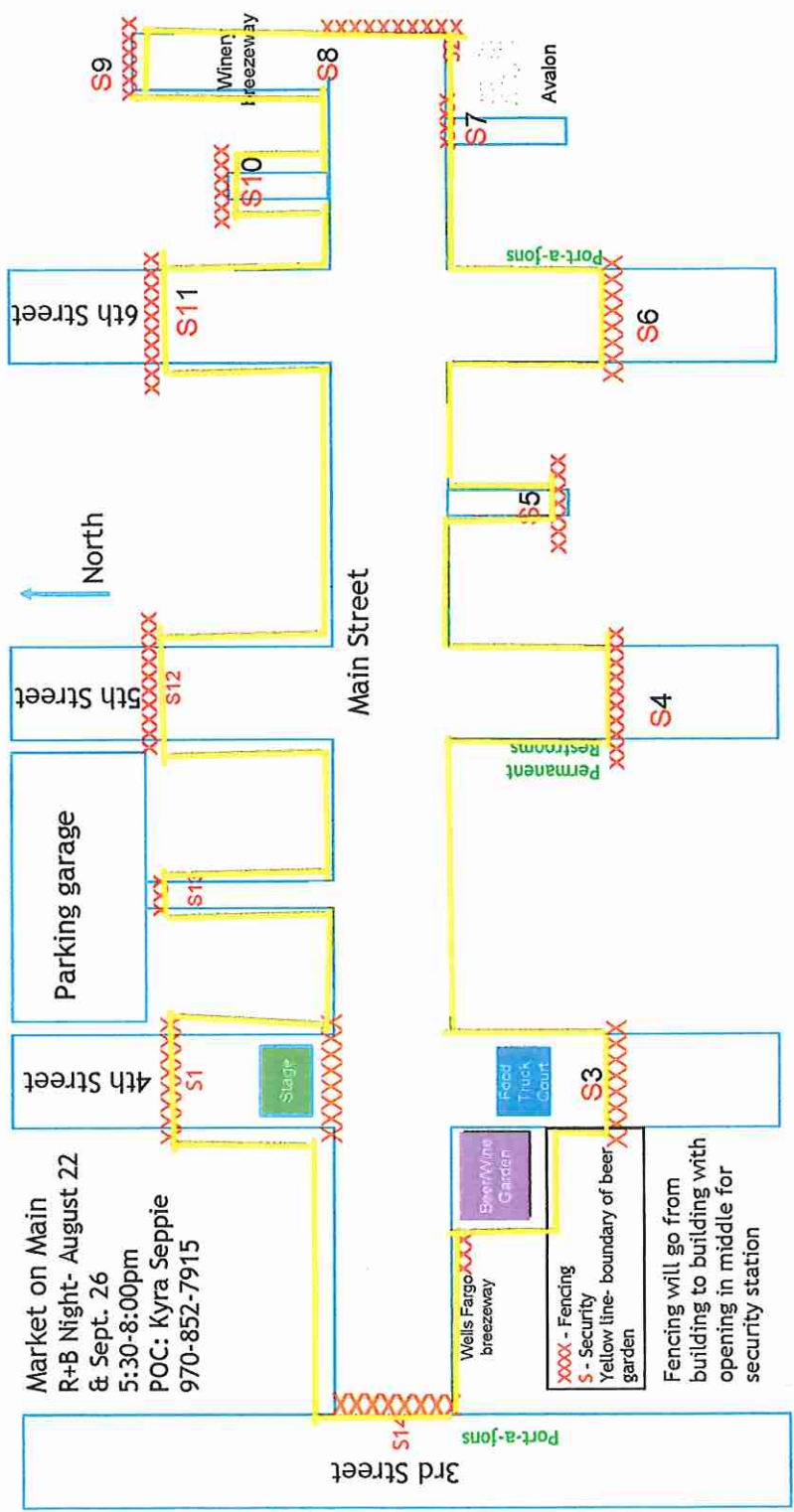

Rhythm & Brews
Summer Concerts
AFTER MARKET
August 22 &
September 26, 2024
POC: Kyra Seppie
970-852-7915

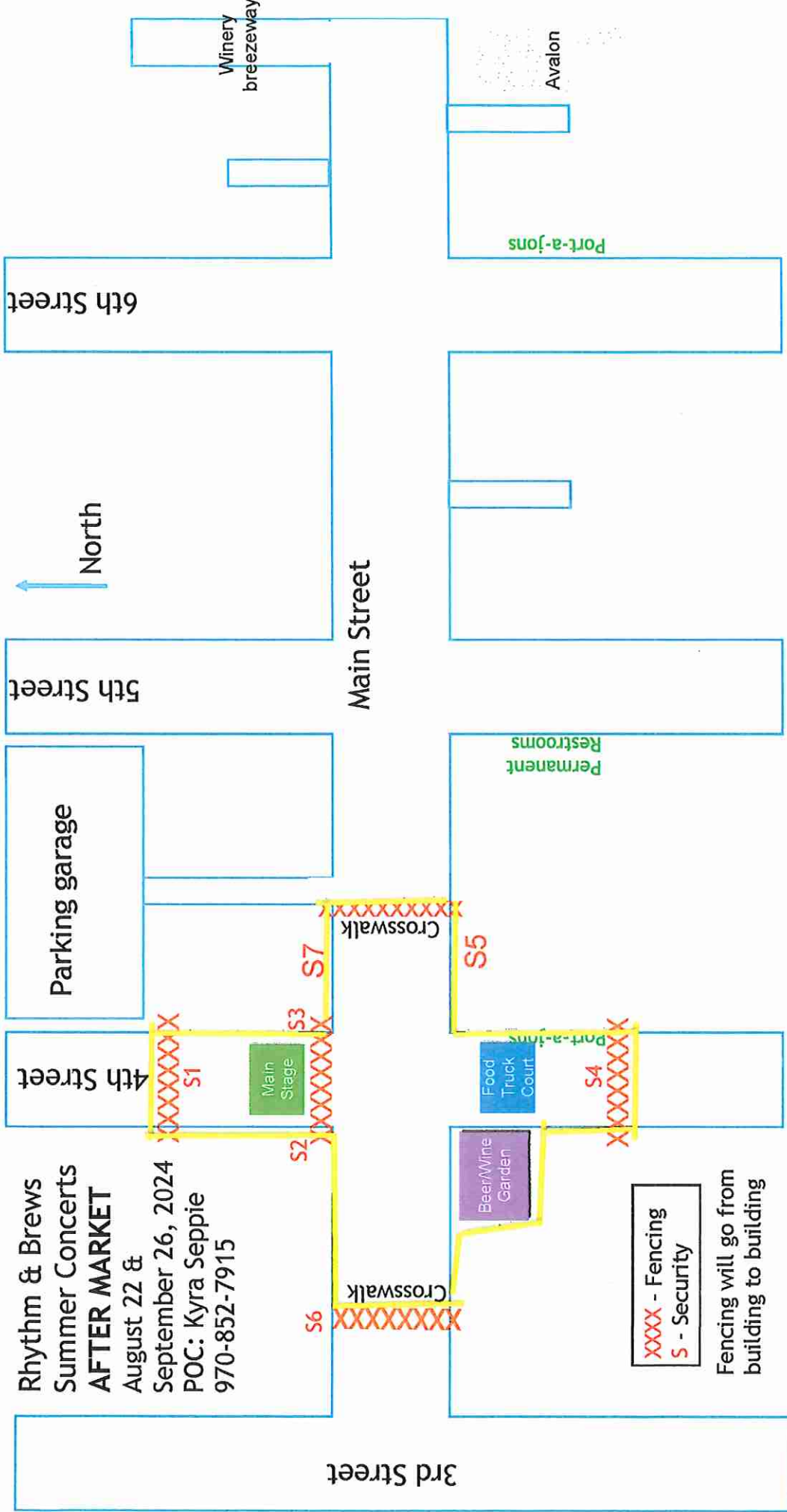

C