



**Purchase Order  
No. 2024-00000680**

**DATE 01/07/2025**

**Ph. (970) 244-1546**

**Fax**

**Ship To** City of Grand Junction  
Pipe Maintenance  
333 West Ave Building E  
Grand Junction, CO 81501

**Bill To** City of Grand Junction  
Pipe Maintenance  
333 West Ave Building E  
Grand Junction, CO 81501

**Vendor** **VENDOR NO. 4571**  
Ferguson Enterprises Inc  
PO Box 802817  
Chicago, IL 60680-2817

**PAGE 1 of 1**  
**SHIP VIA** Best Way  
**DELIVER BY**  
**FREIGHT TERMS** FOB Dest, Frght Prepaid .Allow  
**Payment Terms: Net 30 Days**  
**Buyer Name:** Kassandra Nelson  
**Buyer Email:** kassyh@gjcity.org

Award for IFB-5557-24-KN

QUANTITY	UNIT	DESCRIPTION	UNIT COST	TOTAL COST
1.0000	Lump Su	WATER/PIPELINE - MAINTENANCE AND SUPPLIES - WATER TREATMENT PLANT PIPE REPLACEMENT PROJECT 301-610-010.8410 - Water Supply 56,000.00 F0050-F005016	56,000.0000	\$56,000.00
<b>PURCHASE ORDER TOTAL</b>				<b>\$56,000.00</b>

**Special Instructions:** PURCHASE ORDER No. MUST APPEAR ON ALL INVOICES, SHIPPERS, PACKAGES, CORRESPONDENCE  
**Tax Exempt No. 98-03544**  
This Purchase Order along with all other solicitation documents comprise the entire contract. Send invoices to amyb@gjcity.org.

By: \_\_\_\_\_



Purchasing Division

## Invitation for Bid

IFB-5557-24-KN

C900 PVC Pipe

### **Responses Due:**

January 3, 2025, prior to 2:00 PM Local Time

**Accepting Electronic Responses Only**  
**Responses Only Submitted Through the Rocky Mountain E-**  
**Purchasing [www.bidnetdirect.com/colorado](http://www.bidnetdirect.com/colorado)**

(Purchasing Representative does not have access or control of the vendor side of RMEPS. If website or other problems arise during response submission, vendor **MUST** contact RMEPS to resolve issue prior to the response deadline. 800-835-4603)

### **Purchasing Representative:**

Kassy Nelson, Buyer

[kassy.nelson@gjcity.org](mailto:kassy.nelson@gjcity.org)

Phone (970) 244-1546

**NOTE: Solicitation opening will be held virtually.**  
**See Section 1.7 for details.**

# **Invitation for Bids**

## **Table of Contents**

Section 1	Instruction to Bidders
Section 2	General Contract Conditions
Section 3	Specifications and Special Conditions & Provisions
Section 4	Bid Form

# **1. Instructions to Bidders**

**NOTE:** It is the Contractor's responsibility to read and review all solicitation documentation in its entirety, and to ensure that it has a clear and complete understanding of not only the scope, specifications, project requirements, etc., but also all other requirements, instructions, rules, regulations, laws, conditions, statements, procurement policies, etc. that are associated with the solicitation process and project/Work being solicited.

- 1.1. **A.D.A Document Compliance Requirements:** All work documents, and/or bid/proposal documents submitted, as a result of this solicitation must comply with all applicable provisions of §§24-85-101, C.R.S., et seq., and the Accessibility Standards for Individuals with a Disability, as established by the Office Of Information Technology according to Section §24-85-103 (2.5), C.R.S. and 3) all State of Colorado technology standards related to technology accessibility and with Level A.A. of the most current version of the Web Content Accessibility Guidelines (WCAG), incorporated in the State of Colorado technology standards.
- 1.2. **Issuing Office:** This Invitation for Bid (IFB) is issued by the City of Grand Junction. All contact regarding this IFB is to be directed to:  
  
Kassy Nelson, Buyer  
[kassy.nelson@gjcity.org](mailto:kassy.nelson@gjcity.org)  
  
With the exception of Pre-Bid or Site Visit Meeting(s) all questions, inquiries, comments, or communication pertaining to this solicitation (whether process, specifications, scope, etc.) must be directed in writing to the Purchasing Agent assigned to the project or Purchasing Division. Other communication may result in disqualification.
- 1.3. **Purpose:** The City of Grand Junction is soliciting competitive bids from qualified and interested companies for all labor, equipment, and materials required to provide and deliver pipe. **No installation is required for this purchase. This is a products/materials purchase only.** All specifications and scope of work should be verified by Bidders prior to submission of bids.
- 1.4. **The Owner:** The Owner is the City of Grand Junction, Colorado and is referred to throughout this Solicitation. The term Owner means the Owner or its authorized representative.
- 1.5. **Compliance:** All Contractors, by submitting a bid, agree to comply with all conditions, requirements, and instruction of this IFB as stated or implied herein. Should the Owner omit anything which is necessary to the clear understanding of the requirements, or should it appear that various instructions are in conflict, the Contractor(s) shall secure instructions from the Purchasing Agent prior to submittal deadline.
- 1.6. **Procurement Process:** The most current version of the City of Grand Junction [Purchasing Policy and Procedure Manual](#) is contracting.

- 1.7. **Submission:** Each bid shall be submitted in electronic format only through the Rocky Mountain E-Purchasing website ([www.bidnetdirect.com/colorado](http://www.bidnetdirect.com/colorado)). This site offers both “free” and “paying” registration options that allow for full access of the Owner’s documents and for electronic submission of proposals. (Note: “free” registration may take up to 24 hours to process. Please Plan accordingly.) Please view our “**Electronic Vendor Registration Guide**” at <http://www.gjcity.org/501/Purchasing-Bids> for details. (Purchasing Representative does not have access or control of the vendor side of RMEPS. If website or other problems arise during response submission, vendor **MUST** contact RMEPS to resolve issue prior to the response deadline. **800-835-4603**).

Please join my meeting from your computer, tablet or smartphone.  
<https://meet.goto.com/517742861>

You can also dial in using your phone.  
Access Code: 517-742-861  
United States: +1 (571) 317-3122  
- One-touch: tel:+15713173122,,517742861#

Join from a video-conferencing room or system.  
Meeting ID: 517-742-861  
Dial in or type: 67.217.95.2 or inroomlink.goto.com  
Or dial directly: 517742861@67.217.95.2 or 67.217.95.2##517742861

Get the app now and be ready when your first meeting starts:  
<https://meet.goto.com/install>

- 1.8. **Modification and Withdrawal of Bids Before Opening.** Bids may be modified or withdrawn by an appropriate document stating such, duly executed and submitted to the place where Bids are to be submitted at any time prior to Bid Opening.

A bid must be Contractor and valid for award and may not be withdrawn or cancelled by the Contractor for sixty (60) days following the submittal deadline date, and only prior to award.

- 1.9. **Printed Form for Price Bid:** All Price Bids must be made upon the Price Bid Schedule attached and should give the amounts both in words and in figures and must be signed and acknowledged by the bidder.

The Contractor shall specify a unit price in figures for each pay item for which a quantity is given and shall provide the products (in numbers) of the respective unit prices and quantities in the Extended Amount column. The total Bid price shall be equal to the sum of all extended amount prices. When an item in the Price Bid Schedule provides a choice to be made by the Contractor, Contractor’s choice shall be indicated in accordance with the specifications for that particular item and thereafter no further choice shall be permitted.

Where the unit of a pay item is lump sum, the lump sum amount shall be shown in the "extended amount" column and included in the summation of the total Bid.

All blank spaces in the Price Bid Schedule must be properly filled out.

Bids by corporations must be executed in the corporate name by the president or vice president or other corporate office accompanied by evidence of authority to sign. The corporate address and state of incorporation shall be shown below the signature.

Bids by partnerships must be executed in the partnership name and signed by a partner whose title must appear under the signature and the official address of the partnership must be shown below the signature.

All names must be typed or printed below the signature.

The Contractor's Bid shall contain an acknowledgement of receipt of all Addenda, the numbers of which shall be filled in on the Contractor's Bid Form.

The contact information to which communications regarding the Bid are to be directed must be shown.

- 1.10. **Exclusions:** No oral, telephonic, emailed, or facsimile bid will be considered
- 1.11. **Contract Documents:** The complete IFB and bidder's response compose the Contract Documents. Copies of these documents can be obtained from the City Purchasing website, <https://www.gjcity.org/501/Purchasing-Bids>.
- 1.12. **Examination of Specifications:** Bidders shall thoroughly examine and be familiar with the project Statement of Work. The failure or omission of any Bidder to receive or examine any form, addendum, or other document shall in no way relieve any Bidder from any obligation with respect to its bid. The submission of a bid shall be taken as evidence of compliance with this section. Prior to submitting a bid, each Contractor shall, at a minimum:
  - a. Examine the *Contract Documents* thoroughly;
  - b. Visit the site to familiarize itself with local conditions that may in any manner affect cost, progress, or performance of the Work;
  - c. Become familiar with federal, state, and local laws, ordinances, rules, and regulations that may in any manner affect cost, progress or performance of the Work;
  - d. Study and carefully correlate Bidder's observations with the *Contract Documents*, and;
  - e. Notify the Purchasing Agent of all conflicts, errors, ambiguities, or discrepancies in or among the *Contract Documents* within the designated inquiry period.

- 1.13. Questions Regarding Statement of Work:** Any information relative to interpretation of Scope of Work or specifications shall be requested of the Purchasing Representative, in writing, in ample time prior to the response time.
- 1.14. Addenda & Interpretations:** If it becomes necessary to revise any part of this solicitation, a written addendum will be posted electronically on the City's website at <https://www.gjcity.org/501/Purchasing-Bids>. The Owner is not bound by any oral representations, clarifications, or changes made in the written specifications by Owner, unless such clarification or change is provided in written addendum form from the City Purchasing Representative.
- 1.15. Taxes:** The Owner is exempt from the State, County, and Municipal Sales Tax and Federal Excise Tax; therefore, all fees shall not include taxes.
- 1.16. Sales and Use Taxes:** The Contractor and all Subcontractors are required to obtain exemption certificates from the Colorado Department of Revenue for sales and use taxes in accordance with the provisions of the General Contract Conditions. Bids shall reflect this method of accounting for sales and use taxes on materials, fixtures, and equipment.
- 1.17. Offers Binding 60 Days:** Unless otherwise specified, all formal offers submitted shall be binding for sixty (60) calendar days following opening date, unless the Bidder, upon request of the Purchasing Representative, agrees to an extension.
- 1.18. Exceptions and Substitutions:** All bids meeting the intent of this IFB shall be considered for award. A Contractor taking exception to the specifications does so at the Contractor's risk. The Owner reserves the right to accept or reject any or all substitutions or alternatives. When offering substitutions and/or alternatives, Contractor must state any exception(s) in the section to which the exception(s) pertain. Exception/substitution, if accepted, must meet, or exceed the stated intent and/or specifications. The absence of stated exception(s) indicates that the Contractor has not taken exceptions, and if awarded a Contract shall hold the Contractor responsible to perform in strict accordance with the specifications or scope of the bid and Contract Documents.
- 1.19. Collusion Clause:** Each Offeror by submitting a bid certifies that it is not party to any collusive action or any action that may be in violation of the Sherman Antitrust Act. Any and all bids shall be rejected if there is evidence or reason for believing that collusion exists among the proposers. The Owner may or may not, at its discretion, accept future bids for the same service or commodities for participants in such collusion.
- 1.20. Disqualification of Bidders:** A Bid will not be accepted from, nor shall a Contract be awarded to, any person, Contractor, or corporation that is in arrears to the Owner, upon debt or Contract, or that has defaulted, as surety or otherwise, upon any obligation to the Owner, or that is deemed irresponsible or unreliable.

Bidders may be required to submit satisfactory evidence that it is responsible, have a practical knowledge of the project bid upon and that it has the necessary financial and other resources to complete the proposed Work.

Either of the following reasons, without limitation, shall be considered sufficient to disqualify a Bidder and Bid:

- a. More than one Bid is submitted for the same Work from an individual, Contractor, or corporation under the same or different name; and
- b. Evidence of collusion among Bidders. Any participant in such collusion shall not receive recognition as a Bidder for any future work of the Owner until such participant has been reinstated as a qualified bidder.

**1.21. Public Disclosure Record:** If the Offeror has knowledge of its employee(s) or sub-contractors having an immediate family relationship with an Owner employee or elected official, the Offeror must provide the Purchasing Agent with the name(s) of the individuals. The individuals are required to file a "Public Disclosure Record", a statement of financial interest, before conducting business with the Owner.

**1.22. Public Opening:** Bids shall be opened in a virtual meeting immediately following the bid deadline. Offerors, its representatives and interested persons may be present. Only the name(s) and business address of the Offeror(s) will be disclosed.

## **2. General Contract Conditions**

**2.1. The Contract:** This Invitation for Bid, submitted documents, and any negotiations, when properly accepted by the Owner, shall constitute an enforceable agreement equally binding between the Owner and Contractor. The Contract represents the entire and integrated agreement between the City and the Contractor and supersedes all prior negotiations, representations, or agreements, either written or oral, including the Bid documents. The Contract may be amended or modified with Change Orders, Field Orders, or Amendment.

**2.2. Execution, Correlation, Intent, and Interpretations:** The Contract Documents shall be signed by the Owner and Contractor. By executing the Contract, the Contractor represents that it has familiarized itself with the local conditions under which the Work is to be performed and correlated its observations with the requirements of the Contract Documents. The Contract Documents are complementary, and what is required by anyone, shall be as binding as if required by all. The intention of the Contract Documents is to include all labor, materials, equipment, Work and other items necessary for the proper execution and completion of the Scope of Work as defined in the technical specifications and/or drawings contained herein. All drawings, specifications and copies furnished by the Owner are, and shall remain, Owner property. It's not to be used on any other project.



- 2.3. **The Owner:** The Owner is the City of Grand Junction, Colorado and is referred to throughout this Solicitation. The term Owner means the Owner or its authorized representative.
- 2.4. **Contractor:** The Contractor is the person or organization identified as such in the Agreement and is referred to throughout the Contract Documents. The term Contractor means the Contractor or its authorized representative. The Contractor shall carefully study and compare the General Contract Conditions of the Contract, Specification and/or Drawings, Scope of Work, Addenda and Modifications and shall at once report to the Owner any error, inconsistency, or omission it may discover. Contractor shall not be liable to the Owner for any damage resulting from such errors, inconsistencies, or omissions. The Contractor shall not commence work without clarifying Drawings, Specifications, or Interpretations.
- 2.5. **Warranty:** The Contractor warrants to the Owner that all materials and equipment furnished under this Contract will be new unless otherwise specified, be of good quality, free from faults and defects and in conformance with the Contract Documents. All materials and equipment not so conforming to these standards may be considered defective. If required by Owner, the Contractor shall furnish satisfactory evidence as to the kind and quality of materials and equipment. If within ten (10) days after written notice to the Contractor requesting such repairs or replacement, the Contractor should neglect to make or undertake with due diligence to the same, the City may make such replacements. All indirect and direct costs of such correction or replacement shall be at the Contractor's expense.
- 2.6. **Indemnification:** Contractor shall defend, indemnify and save harmless the Owner and all its officers, employees, insurers, and self-insurance pool, from and against all liability, suits, actions, or other claims of any character, name and description brought for or on account of any injuries or damages received or sustained by any person, persons, or property on account of any negligent act or fault of the Contractor, or of any Contractor's agent, employee, sub-Contractor or supplier in the execution of, or performance under, any Contract which may result from bid award. Contractor shall pay any judgment with costs which may be obtained by and/or against the Owner arising out of or under the performance.
- 2.7. **Miscellaneous Conditions:** Material Availability: Contractors must accept responsibility for verification of material availability, production schedules, and other pertinent data prior to submission of bid. It is the responsibility of the bidder to notify the Owner immediately if materials specified are discontinued, replaced, or not available for an extended period of time. OSHA Standards: All bidders agree and warrant that Work performed in response to this invitation shall conform to the standards declared by the US Department of Labor under the Occupational Safety and Health Act of 1970 (OSHA). In the event the Work does not conform to OSHA standards, the Owner may require the Work to be redone at no additional expense to the Owner.
- 2.8. **Time:** The Contract Time is the period of time allotted in the Contract Documents for completion of product/material receipt. The date of commencement of the Contract is the date established in the Contract Documents.

- 2.9. Payment & Completion:** The Contract Sum is stated in the Contract and is the total amount payable by the Owner to the Contractor for the performance of the Work under the Contract Documents. Upon receipt of written notice that the Work is ready for final inspection and acceptance and upon receipt of application for payment, the Owner's Project Manager will promptly make such inspection and, when it finds the Work acceptable under the Contract Documents and the Contract fully performed, the Owner shall make payment in the manner provided in the Contract Documents. Partial payments will be based upon estimates, prepared by the Contractor, of the value of Work performed and materials placed in accordance with the Contract Documents. The Work performed by Contractor shall be in accordance with generally accepted professional practices and the level of competency presently maintained by other practicing professional Contractors in the same or similar type of Work in the applicable community. The Work to be performed by Contractor hereunder shall be done in compliance with applicable laws, ordinances, rules and regulations.
- 2.10. Protection of Persons & Property:** The Contractor shall comply with all applicable laws, ordinances, rules, regulations, and orders of any public authority having jurisdiction for the safety of persons or property or to protect itself from damage, injury, or loss. Contractor shall erect and maintain, as required by existing safeguards for safety and protection, and all reasonable precautions, including posting danger signs or other warnings against hazards promulgating safety regulations and notifying owners and users of adjacent utilities. When or where any direct or indirect damage or injury is done to public or private property by or on account of any act, omission, neglect, or misconduct by the Contractor in the execution of the Work, or in consequence of the non-execution thereof by the Contractor, it shall restore, at its own expense, such property to a condition similar or equal to that existing before such damage or injury was done, by repairing, rebuilding, or otherwise restoring as may be directed, or it shall make good such damage or injury in an acceptable manner.
- 2.12. Change Order/Amendment:** No oral statement of any person shall modify or otherwise change, or affect the terms, conditions or specifications stated in the Contract. All amendments to the Contract shall be made in writing by the City Contract Administrator.
- 2.13. Assignment:** The Contractor shall not sell, assign, transfer or convey the Contract resulting from this IFB, in whole or in part, without the prior written approval from the Owner.
- 2.14. Cancellation of Solicitation:** Any solicitation may be canceled by the Owner or any solicitation response by a vendor may be rejected in whole or in part when it is in the best interest of the Owner.
- 2.15. Compliance with Laws:** Responses must comply with all Federal, State, County and local laws governing of the service and the fulfillment of the Service(s) for and on behalf of the public. Contractor hereby warrants that it is qualified to assume the responsibilities and render the Work described herein and has all requisite corporate authority and professional licenses in good standing, required by law.

- 2.16. Confidentiality:** All materials submitted in response to this Solicitation shall ultimately become public record and shall be subject to inspection after Contract award. "**Proprietary or Confidential Information**" is defined as any information that is not generally known to competitors and which provides a competitive advantage. Unrestricted disclosure of proprietary information places it in the public domain. Only submittal information clearly identified with the words "**Confidential Disclosure**" and uploaded as a separate document shall establish a confidential, proprietary relationship. Any material to be treated as confidential or proprietary in nature must include a justification for the request. The request shall be reviewed and either approved or denied by the Owner. If denied, the proposer shall have the opportunity to withdraw its entire bid, or to remove the confidential or proprietary restrictions. Neither cost nor pricing information nor the total response shall be considered confidential or proprietary.
- 2.17. Conflict of Interest:** No public official and/or Owner employee shall have interest in the Contract resulting from this Invitation for Bid.
- 2.18. Contract Termination:** The Contract shall remain in effect until any of the following occurs: (1) Contract expires; (2) completion of Work; (3) final acceptance of Work or, (4) for convenience terminated by either party with a written *Notice of Cancellation* stating therein the reasons for such cancellation and the effective date of cancellation at least thirty days past notification.
- 2.19. Employment Discrimination:** During the performance of any Work per agreement with the Owner, the Contractor, agrees to:
- 2.19.1.** Not discriminate against any employee or applicant for employment because of race, religion, color, sex, age, disability, citizenship status, marital status, veteran status, sexual orientation, national origin, or any legally protected status except when such condition is a legitimate occupational qualification reasonably necessary for the normal operations of the Contractor. The Contractor agrees to post in conspicuous places, visible to employees and applicants for employment, notices setting forth the provisions of this nondiscrimination clause.
- 2.19.2.** In all solicitations or advertisements for employees placed by or on behalf of the Contractor, that the Contractor is an Equal Opportunity Employer.
- 2.19.3.** Notices, advertisements, and solicitations placed in accordance with federal law, rule, or regulation shall be deemed sufficient for the purpose of meeting the requirements of this section.
- 2.20. Immigration Reform and Control Act of 1986 and Immigration Compliance:** The Contractor certifies that it does not and will not during the performance of the Contract employ Service(s)er without authorization Work or otherwise violate the provisions of the Federal Immigration Reform and Control Act of 1986 and/or law regulating immigration compliance.

- 2.21. Ethics:** The Contractor shall not accept or offer gifts or anything of value and/or enter into any business arrangement with any employee, official, or agent of the Owner.
- 2.22. Failure to Deliver:** In the event of failure of the Contractor to perform in accordance with the Contract Documents, the Owner, after due oral or written notice, may procure Work from other sources and hold the Contractor responsible for any and all costs resulting in the purchase of additional Work and materials necessary to perform the Service(s). This remedy shall be in addition to any other remedies that the Owner may have.
- 2.23. Failure to Enforce:** Failure by the Owner at any time to enforce the provisions of the Contract shall not be construed as a waiver of any such provisions. Such failure to enforce shall not affect the validity of the Contract or any part thereof or the right of the Owner to enforce any provision of the Contract Documents at any time in accordance with the terms thereof.
- 2.24. Force Majeure:** The Contractor shall not be held responsible for failure to perform the duties and responsibilities imposed by the Contract due to legal strikes, fires, riots, rebellions, and acts of God beyond the control of the Contractor, unless otherwise specified in the Contract.
- 2.25. Independent Contractor:** The Contractor shall be legally considered an independent Contractor and neither the Contractor nor its employees shall, under any circumstances, be considered servants or agents of the Owner. The Owner shall be at no time legally responsible for any negligence or other wrongdoing by the Contractor, its servants, or agents. The Owner shall not withhold from the Contractor payments to the Contractor any federal or state unemployment taxes, federal or state income taxes, Social Security, or any other amounts for benefits to the Contractor. Further, the Owner shall not provide to the Contractor any insurance coverage or other benefits, including Service(s)ers' Compensation, normally provided by the Owner for its employees.
- 2.26. Nonconforming Terms and Conditions:** A response that includes terms and conditions that do not conform to the terms and conditions of this Solicitation is subject to rejection as non-responsive. The Owner reserves the right to permit the Contractor to withdraw nonconforming terms and conditions from its response prior to a determination by the Owner of non-responsiveness based on the submission of nonconforming terms and conditions.
- 2.27. Ownership:** All plans, prints, designs, concepts, etc., shall become the property of the Owner.
- 2.28. Patents/Copyrights:** The Contractor agrees to protect the Owner from any claims involving infringements of patents and/or copyrights. In no event shall the Owner be liable to the Contractor for any/all suits arising on the grounds of patent(s)/copyright(s) infringement. Patent/copyright infringement shall null and void any agreement resulting from response to this Solicitation.

- 2.29. Remedies:** The Contractor and Owner agree that both parties have all rights, duties, and remedies available as stated in the Uniform Commercial Code.
- 2.30. Governing Law:** Any agreement as a result of responding to this Solicitation shall be deemed to have been made in, and shall be construed and interpreted in accordance with, the laws of the City of Grand Junction, Mesa County, Colorado.
- 2.31. Expenses:** Expenses incurred in preparation, submission, and presentation of a response to this Solicitation are the responsibility of the Contractor and cannot be charged to the Owner.
- 2.32. Sovereign Immunity:** The Owner specifically reserves its right to sovereign immunity pursuant to Colorado Law as a defense to any action arising out of or under a Contract.
- 2.33. Public Funds/Non-Appropriation of Funds:** Funds for payment have been provided through the Owner's budget approved by the City Council/Board of County Commissioners for the stated fiscal year only. Colorado law prohibits the obligation and expenditure of public funds beyond the fiscal year for which a budget has been approved. Therefore, anticipated orders or other obligations that may arise past the end of the stated Owner's fiscal year shall be subject to budget approval. The Contract will be subject to and provide a non-appropriation of funds clause.
- 2.34. Cooperative Purchasing:** Purchases as a result of this solicitation are primarily for the Owner. Other governmental entities may be extended the opportunity to utilize the resultant Contract award with the agreement of the successful provider and the participating agencies. All participating entities shall be required to abide by the specifications, terms, conditions, and pricings established in this Solicitation. The quantities furnished in this bid document are for only the Owner. It does not include quantities for any other jurisdiction. The Owner shall be responsible only for the award for its jurisdiction. Other participating entities shall place its own awards on its respective Contract/Purchase Orders through its Purchasing Office or use its Purchasing Card for purchase/payment as authorized or agreed upon between the provider and the individual entity. The Owner accepts no liability for payment of orders placed by other participating jurisdictions that choose to piggy-back on our solicitation. Orders placed by participating jurisdictions under the terms of this solicitation shall indicate its specific delivery and invoicing instructions.
- 2.35. Definitions:**
- 2.35.1.** The term "Work" includes all labor, materials, equipment, and/or services necessary to produce the requirements of the Contract Documents.
- 2.35.2.** "City" is the City of Grand Junction, Colorado and is referred to throughout the Contract Documents. The term City means the City or its authorized representative. Based on such observations and the Contractor's Application for Payment, the City will determine the amounts owing to the Contractor and will issue Certificates for Payment in such amounts, as provided in the Contract. The City will have authority to reject

Service(s) which does not conform to the Contract documents. Whenever, in its reasonable opinion, it considers it necessary or advisable to ensure the proper implementation of the intent of the Contract Documents, it will have authority to require the Contractor to stop the Service(s) or any portion, or to require special inspection or testing of the Service(s), whether or not such Service(s) can be then be fabricated, installed, or completed. The City will not be responsible for the acts or omissions of the Contractor, and sub-Contractor, or any of its agents or employees, or any other persons performing any of the Service(s).

**2.35.3.** "Contractor" is the person, organization, Contractor, or consultant identified as such in the Agreement and is referred to throughout the Contract Documents. The term Contractor means the Contractor or its authorized representative. The Contractor shall carefully study and compare the General Contract Conditions of the Contract, Specification and Drawings, Scope of Work, Addenda and Modifications and shall at once report to the Owner any error, inconsistency, or omission it may discover. Contractor shall not be liable to the Owner for any damage resulting from such errors, inconsistencies, or omissions. The Contractor shall not commence Work without clarifying Drawings, Specifications, or Interpretations.

**2.35.4.** "Sub-Contractor" is a person or organization who has a direct Contract with the Contractor to perform any of the work at the site. The term sub-contractor is referred to throughout the Contract documents and means a sub-contractor or its authorized representative.

### **3. Specifications and Special Conditions & Provisions**

**3.1. General:** The City of Grand Junction is accepting competitive pricing, from qualified and interested companies, to supply and deliver **pipe that meet the specifications listed in Section 3 "Specifications and Special Conditions"**.

**No installation is required for this purchase. This is a products/materials purchase only.**

This solicitation is for 1000 LF of 20" C900 PVC pipe. Delivery costs of the product to the City of Grand Junction must be included in the bid price.

**3.2. Specifications:** See Price Bid Schedule for product specifications.

**Note:**

- No Brands are Excluded provided that the pipe is AWWA approved and has a pressure rating of DR18 and DR25.
- Tracer wire is not part of this material purchase

**3.3. Special Conditions & Provisions:**

**3.3.1. Questions Regarding Solicitation Process/Scope of Work:**

Kassy Nelson, Buyer  
City of Grand Junction  
[kassy.nelson@gjcity.org](mailto:kassy.nelson@gjcity.org)

- 3.3.2. Project Manager:** The Project Manager for the Project is Mark Ritterbush, who can be reached at 970-256-4185. After Award, all notices, letters, submittals, and other communications directed to the City shall be addressed and mailed or delivered to:

City of Grand Junction  
Utilities Department  
Attn: Mark Ritterbush, Project Manager  
333 West Ave, Bldg E  
Grand Junction, CO 81505

- 3.3.3. Contract Administrator:** The Contract Administrator for the Project is Duane Hoff Jr., Contract Administrator, who can be reached at (970) 244-1545. After Award, contract related inquiries, issues, and other communications shall be directed to:

Duane Hoff Jr., Contract Administrator  
[duaneh@gjcity.org](mailto:duaneh@gjcity.org)

- 3.3.4. Materials Specifications Sheet:** Bidders shall supply materials specifications sheets and MSDS (Material Safety Data Sheets) for all products proposed for bid, with their bid submittals.

- 3.3.5. Rejection of Products/Supplies:** The City of Grand Junction reserves the right to return products/supplies due to product flaws and/or not meeting specifications. Judgment of non-conformity will be at the discretion of the City of Grand Junction Project Manager.

- 3.3.6. Delivery Schedule:** See Bid Schedule to complete estimated delivery.

- 3.3.7. Delivery Location:** The order of materials shall be delivered tot Grand Junction Water Treatment Plant located at **244 26 ¼ Road, Grand Junction, CO 81503.** Driving directions to delivery location are as follows:

Heading south on US Hwy 50 from downtown Grand Junction go over the Colorado River and veer right at the first stoplight (Unaweep Ave). Continue heading south on 26 ¼ Road proceeding through the cemetery. Go straight at the first stop sign, continuing on the paved road through the south half of the cemetery then up the hill to the water treatment plant at the end of the road.

**\*\*\*\*Please call before delivery to verify proper location of material drop. \*\*\*\* Andy Thatcher 970-244-1578.**

**3.3.8. Estimated Quantities:** The quantities indicated in this Invitation for Bid are estimates that pertain to the total aggregate quantities that may be ordered throughout the stated Contract period. Variation of quantities may increase or decrease. The estimates do not indicate single order amounts unless otherwise stated. The Owner makes no guarantees about single order quantities or total aggregate order quantities.

**3.3.9. Minimum Order Quantities:** The bidder shall not establish a minimum order quantity for items under contract.

**3.3.10. Pricing:** Pricing shall be all inclusive, to include, but not be limited to: labor, materials, shipping/freight, etc.

All prices shall be "F.O.B. Destination Freight Pre-Paid and Allowed". The Owner shall not pay nor be liable for any other additional costs including but not limited to: taxes, shipping charges, insurance, interest, penalties, termination payments, attorney fees, liquidated damages, etc.

**3.3.11. Contract:** A binding contract shall consist of: (1) the IFB and any amendments thereto, (2) the bidder's response (bid) to the IFB, (3) clarification of the bid, if any, and (4) the City's Purchasing Department's acceptance of the bid by "Notice of Award" or by "Purchase Order". All Exhibits and Attachments included in the IFB shall be incorporated into the Contract by reference.

A. The Contract expresses the complete agreement of the parties and, performance shall be governed solely by the specifications and requirements contained therein.

B. Any change to the contract, whether by modification and/or supplementation, must be accomplished by a formal Contract amendment signed and approved by and between the duly authorized representative of the bidder and the City Purchasing Division or by a modified Purchase Order prior to the effective date of such modification. The bidder expressly and explicitly understands and agrees that no other method and/or no other document, including acts and oral communications by or from any person, shall be used or construed as an amendment or modification to the contract.

**3.3.12. Packing Slips or Delivery Tickets:** All shipments or deliveries shall be accompanied by Packing Slips or Delivery Tickets, and shall contain the following information for each item delivered:

- The purchase order number
- The name of the article and stock number
- The quantity ordered
- The quantity shipped
- The quantity back ordered
- The name of the vendor(s)



**3.3.13. Authorized Representatives of the City:** Those authorized to represent the City shall include Purchasing Agent, Engineers, and Inspectors employed by the City, only.

**3.4. Contractor's Bid Documents:** For Contractor's convenience, the following is a list of forms/items to be submitted with the Contractor's bid response. However, should a form/item not be listed in this section, but required in the solicitation documents, it is the Contractor's responsibility to ensure all forms/items are submitted.

- Contractor's Bid Form
- Price Bid Schedule
- Materials Specifications Sheets

**3.5. IFB Tentative Time Schedule:**

- |  |                   |
|--|-------------------|
| • Invitation for Bids available                  | December 12, 2024 |
| • Inquiry deadline, no questions after this date | December 26, 2024 |
| • Addendum issued, if needed                     | December 27, 2024 |
| • Response Deadline                              | January 3, 2025   |
| • Purchase Order execution                       | January 10, 2025  |



Purchasing Division

## **ADDENDUM NO. 1**

**DATE:** December 27, 2024  
**FROM:** City of Grand Junction Purchasing Division  
**TO:** All Offerors  
**RE:** C900 PVC Pipe IFB-5557-24-KN

Offerors responding to the above referenced solicitation are hereby instructed that the requirements have been clarified, modified, superseded and supplemented as to this date as hereinafter described.

Please make note of the following clarifications:

- Q:** In section 3.3.8 Estimated Quantities, there is a reference to the Contract Period in regards to the finalized amount of pipe to be ordered. We do not see a specific Contract Period stated in this IFB, can you please clarify?  
**A:** This is a one-time purchase. However, this clause remains just in case prices come in higher than what the City has budgeted and we need to adjust quantities ordered.

The original solicitation for the project noted above is amended as noted.

All other conditions of subject remain the same.

Respectfully,

A handwritten signature in black ink that reads "K Nelson". The signature is written in a cursive, flowing style.

Kassy Nelson, Buyer  
City of Grand Junction, Colorado

## 4. Contractor's Bid Form

Bid Date: 12/23/2024

Project: IFB-5557-24-KN "C900 PVC Pipe"

Bidding Company: Ferguson

Name of Authorized Agent: Jared Crosby

Email jared.crosby@ferguson.com

Telephone 970-497-9465

Address 2868 I-70BL

City Grand Junction

State CO

Zip 81501

The undersigned Bidder, in compliance with the Invitation for Bids, having examined the Instruction to Bidders, General Contract Conditions, Statement of Work, Specifications, and any and all Addenda thereto, having investigated the location of, and conditions affecting the proposed work, hereby proposes to furnish all labor, materials and supplies, and to perform all work for the Project in accordance with Contract Documents, within the time set forth and at the prices stated below. These prices are to cover all expenses incurred in performing the work required under the Contract Documents, of which this Contractor's Bid Form is a part.

The undersigned Contractor does hereby declare and stipulate that this offer is made in good faith without collusion or connection to any person(s) providing an offer for the same work, and that it is made in pursuance of, and subject to, all terms and conditions of the Instructions to Bidders, the Specifications, and all other Solicitation Documents, all of which have been examined by the undersigned.

The Contractor also agrees that if awarded the Contract, to provide insurance certificates within ten (10) working days of the date of Notification of Award. Submittal of this offer will be taken by the Owner as a binding covenant that the Contractor will be prepared to complete the project in its entirety.

The Owner reserves the right to make the award on the basis of the offer deemed most favorable, to waive any formalities or technicalities and to reject any or all offers. It is further agreed that this offer may not be withdrawn for a period of sixty (60) calendar days after closing time. Submission of clarifications and revised offers automatically establish a new thirty day (30) period.

Prices in the bid proposal have not knowingly been disclosed with another provider and will not be prior to award.

- Prices in this bid proposal have been arrived at independently, without consultation, communication or agreement for the purpose of restricting competition.
- No attempt has been made nor will be to induce any other person or Contractor to submit a bid proposal for the purpose of restricting competition.
- The individual signing this bid proposal certifies they are a legal agent of the offeror, authorized to represent the offeror and is legally responsible for the offer with regard to supporting documentation and prices provided.
- Direct purchases by the City of Grand Junction are tax exempt from Colorado Sales or Use Tax. Tax exempt No. 98-903544. The undersigned certifies that no Federal, State, County or Municipal tax will be added to the above quoted prices.
- City of Grand Junction payment terms shall be Net 30 days.
- Prompt payment discount of 0 percent of the net dollar will be offered to the Owner if the invoice is paid within Net 30 days after the receipt of the invoice. The Owner reserves the right to take into account any such discounts when determining the bid award.

RECEIPT OF ADDENDA: the undersigned Contractor acknowledges receipt of Addenda to the Solicitation, Specifications, and other Contract Documents.

State number of Addenda received: 0

It is the responsibility of the Bidder to ensure all Addenda have been received and acknowledged.

By signing below, the Undersigned agree to comply with all terms and conditions contained herein.

Company: FERGUSON ENTERPRISES, LLC

Authorized Signature: [Signature]

Title: GENERAL MANAGER

**PRICE BID SCHEDULE: IFB-5557-24-KN C900 PVC Pipe**

Item	CDOT City Ref.	Description	Estimated Qty	Unit	Unit Price	Extended Price
1	108.2	Water Main (20") (C900 PVC, DR-25)	1,000	LF	\$56.00	\$56000.00

**Total Extended Price Written:**

\$56000.00

---

**State Lead Time:**

1-2 weeks

---

By signing below, the Undersigned agree to comply with all terms and conditions contained herein.

Company: FERGUSON ENTERPRISES, LLC

Authorized Signature: 

Title: GENERAL MANAGER

<b>Deliver To:</b> <b>From:</b> Jared Crosby jared.crosby@gjpipe.com <b>Comments:</b>
--

FERGUSON WATERWORKS #2750  
Price Quotation  
Phone: 970-240-2199  
Fax: 970-240-2772

**Bid No:** B376629  
**Bid Date:** 12/20/24  
**Quoted By:** JDC

**Cust Phone:** 970-244-1487  
**Terms:** NET 10TH PROX

**Customer:** CITY OF GRAND JUNCTION  
2145 RIVER ROAD  
GRAND JCT, CO 81505

**Ship To:** CITY OF GRAND JUNCTION  
2145 RIVER ROAD  
GRAND JCT, CO 81505

**Cust PO#:** IFB-5557-24-KN

**Job Name:** C900 PVC PIPE

Item	Description	Quantity	Net Price	UM	Total
DR25BP20	20 C900 DR25 CL165 PVC GJ BLUE PIPE	1000	56.000	FT	56000.00
<b>Net Total:</b>					\$56000.00
<b>Tax:</b>					\$0.00
<b>Freight:</b>					\$0.00
<b>Total:</b>					\$56000.00

Quoted prices are based upon receipt of the total quantity for immediate shipment (48 hours). SHIPMENTS BEYOND 48 HOURS SHALL BE AT THE PRICE IN EFFECT AT TIME OF SHIPMENT UNLESS NOTED OTHERWISE. QUOTES FOR PRODUCTS SHIPPED FOR RESALE ARE NOT FIRM UNLESS NOTED OTHERWISE.

CONTRACTOR CUSTOMERS: IF YOU HAVE DBE/MBE/WBE/VBE/SDVBE/SBE GOOD FAITH EFFORTS DIVERSITY GOALS/ REQUIREMENTS ON A FEDERAL, STATE, LOCAL GOVERNMENT, PRIVATE SECTOR PROJECT, PLEASE CONTACT YOUR BRANCH SALES REPRESENTATIVE IMMEDIATELY PRIOR TO RECEIVING A QUOTE/ORDER.

Seller not responsible for delays, lack of product or increase of pricing due to causes beyond our control, and/or based upon Local, State and Federal laws governing type of products that can be sold or put into commerce. This Quote is offered contingent upon the Buyer's acceptance of Seller's terms and conditions, which are incorporated by reference and found either following this document, or on the web at <https://www.ferguson.com/content/website-info/terms-of-sale>  
Govt Buyers: All items are open market unless noted otherwise.

LEAD LAW WARNING: It is illegal to install products that are not "lead free" in accordance with US Federal or other applicable law in potable water systems anticipated for human consumption. Products with \*NP in the description are NOT lead free and can only be installed in non-potable applications. Buyer is solely responsible for product selection.

Buyer shall accept delivery of products within 60 days of Seller receiving the products at Seller's warehouse. If Buyer causes or requests a delay in delivery of the products, Buyer may be subject to storage fees and additional costs caused by such delay. Seller reserves the right to requote the products and reschedule the delivery date, subject to manufacturer's lead times and price increases, if Buyer is unable to accept delivery within 60 days.



**HOW ARE WE DOING? WE WANT YOUR FEEDBACK!**

Scan the QR code or use the link below to complete a survey about your bids:

<https://survey.medallia.com/?bidsorder&fc=2745&on=55720>

# VINYLTECH AWWA C900 BLUE

## TECHNICAL DATA SUBMITTAL (14" - 24")



### CONFORMANCE

These specifications designate the requirements for manufacturing and installing Vinyltech AWWA C900 PVC Pressure Pipe for potable water (14"-24").

**ANSI/AWWA C900** - Polyvinyl Chloride (PVC) Pressure Pipe and Fabricated Fittings, 4" Through 60" (100mm Through 1,500mm)

**AWWA C605** - Underground Installation of Polyvinyl Chloride (PVC) Pressure Pipe and Fittings for Water ASTM D1784 - Standard Specification for Rigid Poly (Vinyl Chloride) (PVC) Compounds and Chlorinated Poly (Vinyl Chloride) (CPVC) Compounds

**ASTM D1784** - Standard Specification for Rigid Poly (Vinyl Chloride) (PVC) Compounds and Chlorinated Poly (Vinyl Chloride) (CPVC) Compounds

**ASTM D3139** - Standard Specification for Joints for Plastic Pressure Pipes Using Flexible Elastomeric Seals

**ASTM F477** - Standard Specification for Elastomeric Seals (Gaskets) for Joining Plastic Pipe

**NSF/ANSI 61, Annex G** "Drinking Water Systems Components-Health Effects"

### PIPE COMPOUND

The pipe shall be extruded from compounds meeting (PVC1120) the requirements of Cell Classification 12454, as defined in ASTM D1784, Standard Specification for Rigid Poly (Vinyl Chloride) (PVC) Compounds and Chlorinated Poly (Vinyl Chloride) (CPVC) Compounds. The PVC shall also be listed by the National Sanitation Foundation (NSF) for use in potable water.

### PIPE

Vinyltech pipe shall be manufactured in accordance with AWWA C900.

### GASKET JOINT

The gasket shall be reinforced with a steel band and meet the requirements of ASTM F477. Vinyltech pipe shall have an integral bell end with a locked-in factory installed gasket and shall meet the joint requirements of ASTM D3139.

### MARKING

The pipe shall be marked in accordance with AWWA C900.

### QUALITY CONTROL

05/2024

Each length of the pipe including the bell shall be hydrostatically tested in accordance with AWWA C900. The pipe shall meet all additional test requirements as described in AWWA C900. Our full-time quality assurance staff continually administers a rigid program of tests to maintain the production of the best quality pipe products available.

### INSTALLATION

Recommended installation procedures of Vinyltech Corporation are outlined in AWWA C605, Underground Installation of Polyvinyl Chloride (PVC) Pressure Pipe and Fittings for Water. The AWWA Manual M23, PVC Pipe-Design and Installation, is also an invaluable resource guide for design and installation.

### TAPPING

The consistent success of tapping PVC pressure pipe is contingent upon the use of proper procedures and equipment. Vinyltech recommends strict compliance with the requirements as specified in AWWA C605.

### ASSEMBLING THE PIPE

Assembly of Vinyltech PVC water pipe is easily accomplished. A depth of entry mark is on each spigot end to serve as a visual check for rapid, accurate joint inspection. **Do not over insert.**

- 1) Remove any mud, sand, or other foreign matter from the belled and spigot ends of the pipe. Carefully clean the gasket area.
- 2) With a clean applicator (a brush or hand) lubricate the entire surface of the pipe from the spigot end to the depth of entry mark and the contact surface of the gasket with **Vinyltech Brand Lubricant**.
- 3) Brace the bell to avoid disturbing the already installed joints. Align the pipe, insert the spigot into the bell and push.
- 4) **Do not insert past the entry mark line.**



## C900 DR 25 Pressure Class 165

NOMINAL SIZE		OUTER DIAMETER (IN)	MINIMUM WALL (IN)	FEET PER LIFT	LIFTS PER TRUCK	APPROXIMATE WEIGHT (LB/100')
(IN)	(mm)					
14	350	15.3	0.612	120	12	1935
16	400	17.4	0.696	40/60	20	2575
18	450	19.5	0.78	40/60	20	3165
*20	500	21.6	0.864	80	8	3900
*24	600	25.8	1.032	60	6	5600

## C900 DR 21 Pressure Class 200

NOMINAL SIZE		OUTER DIAMETER (IN)	MINIMUM WALL (IN)	FEET PER LIFT	LIFTS PER TRUCK	APPROXIMATE WEIGHT (LB/100')
(IN)	(mm)					
14	350	15.3	0.729	120	12	2210
16	400	17.4	0.829	40/60	20	2883
18	450	19.5	0.929	40/60	20	3635
*20	500	21.6	1.029	80	8	4468
*24	600	25.8	1.229	60	6	6420

## C900 DR 18 Pressure Class 235

NOMINAL SIZE		OUTER DIAMETER (IN)	MINIMUM WALL (IN)	FEET PER LIFT	LIFTS PER TRUCK	APPROXIMATE WEIGHT (LB/100')
(IN)	(mm)					
14	350	15.3	0.85	120	12	2650
16	400	17.4	0.967	40/60	20	3475
18	450	19.5	1.083	40/60	20	4340
*20	500	21.6	1.200	80	8	5350
*24	600	25.8	1.433	60	6	7650

## C900 DR 14 Pressure Class 305

NOMINAL SIZE		OUTER DIAMETER (IN)	MINIMUM WALL (IN)	FEET PER LIFT	LIFTS PER TRUCK	APPROXIMATE WEIGHT (LB/100')
(IN)	(mm)					
14	350	15.3	1.093	120	12	3300
16	400	17.4	1.243	40/60	20	4450
*18	450	19.5	1.393	40/60	20	5341
*20	500	21.6	1.543	80	8	6566

\*Northern Pipe Products

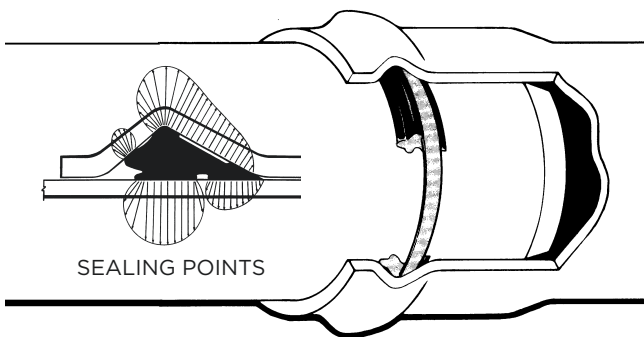

### The Rieber Sealing System

The Rieber system provides a proven pipe joint with an excellent track record in the field. It is the fastest growing system in the world because of its many advantages.

- Factory installed, locked-in gasket
- The pipe bell forms over the gasket, making a perfect fit
- Avoids the possibility of installing the wrong gasket
- Reduces installation problems
- The locked-in gasket eliminates gasket roll-out during joining
- The gasket is molded vs. extruded and spliced
- Works equally well under pressure or vacuum
- Three sealing points achieved vs. two
- **LEAK-PROOF JOINTS**
- **"THE WORLDS BEST JOINT"**