



**Purchase Order
No. 2024-00000624**

DATE 11/26/2024

Ph. (970) 256-4048

Fax

Ship To City of Grand Junction
Public Works Administration
333 West Ave
GRAND JUNCTION, CO 81501

Bill To City of Grand Junction
Public Works Administration
333 West Ave
GRAND JUNCTION, CO 81501

Vendor

VENDOR NO. 1362
CC Enterprises - Traffic Control Specialists, Inc.
ACH
830 21 1/2 Rd
Grand Junction, CO 81505
Phone: (970) 242-0669

PAGE 1 of 1
SHIP VIA Best Way
DELIVER BY 03/10/2025
FREIGHT TERMS FOB Dest, Frght Prepaid ,Allow
Payment Terms: Net 30 Days
Buyer Name: Dolly Daniels
Buyer Email: dollyd@gjcity.org

Award IFB-5521-24-DD

| QUANTITY | UNIT | DESCRIPTION | UNIT COST | TOTAL COST |
|-----------------------------|------|--|--------------|---------------------|
| 1.0000 | Each | CONTRACT SERVICES - PARKS - PEDESTRIAN LIGHTING IMPROVMENTS 201-710-385-380.4200_03 - Grant/Reimb Rev_State 370,060.17 ZDCJ-CPTST23 | 370,060.1700 | \$370,060.17 |
| 1.0000 | Each | CONTRACT SERVICES - Minor Contract Revisions 201-710-385-380.4200_03 - Grant/Reimb Rev_State 15,000.00 ZDCJ-CPTST23 | 15,000.0000 | \$15,000.00 |
| 1.0000 | Each | CONTRACT SERVICES - Retainage 201-710-385-380.4200_03 - Grant/Reimb Rev_State 20,266.33 ZDCJ-CPTST23 | 20,266.3300 | \$20,266.33 |
| PURCHASE ORDER TOTAL | | | | \$405,326.50 |

Special Instructions: PURCHASE ORDER No. MUST APPEAR ON ALL INVOICES, SHIPPERS, PACKAGES, CORRESPONDENCE
Tax Exempt No. 98-03544

By: Dolly f. Daniels



NOTICE TO PROCEED

Date: January 22, 2025

Contractor: CC Enterprises – Traffic Control Specialists, Inc

Project: Parks Pedestrian Lighting Improvements IFB-5521-24-DD

In accordance with the Contract dated December 30, 2024, the Contractor is hereby notified to begin work on the Project on or before January 27, 2025.

The date of final completion as determined is 109 Calendar Days from this Notice To Proceed.

CITY OF GRAND JUNCTION, COLORADO

Dolly Daniels, Senior Buyer

Receipt of this Notice to Proceed is hereby acknowledged:

Contractor: CC Enterprises- Traffic Control Specialists, Inc

By: Signed by: Jeff York

Print Name: Jeff York

Title: Project Manager

Date: 1/24/2025

CHANGE ORDER

Number 1

Date: February 21, 2025
 To: CC Enterprises - Traffic Control Specialists, Inc.
 From: City of Grand Junction, Department of Engineering & Transportation
 Project: **Parks Pedestrian Lighting Improvements IFB-5521-24-DD**
 P.O.: **2024-00000624**

It is agreed to modify the Contract for the Project as follows:

Add two (2) SB lights, four (4) lighting controls and two (2) pull boxes to the volleyball courts at Columbine Park.

Summary of Contract price adjustments - itemized on the attached sheet(s):

| | |
|--------------------------|------------------|
| Original Contract Amount | \$405,326.50 |
| Approved Change Orders | 0.00 |
| This Change Order | <u>32,250.00</u> |
| Revised Contract Amount | \$437,576.50 |

Summary of Contract time adjustments:

| | | |
|------------------------|-----------|-----------|
| Original Contract Time | 109. | Cal. Days |
| Approved Change Orders | 0. | |
| This Change Order | <u>0.</u> | |
| Revised Contract Time | 109. | Cal. Days |

Construction Start Date: January 27, 2025
 Contract Completion Date: May 15, 2025

This modification constitutes compensation in full for all costs and mark-ups directly and/or indirectly attributable to the changes ordered herein, for all delays, impacts and disruptions related thereto and for performance of the changes within the Contract Time.

Owner: **City of Grand Junction**

Prepared by: Signed by: Evan Sales Date: 2/21/2025
D55A9F8B5B47440
 Evan Sales, Engineering Specialist

Recommended by: Signed by: Eric Mocko Date: 2/21/2025
66FB30896C26493
 Eric Mocko, Transportation Engineer

Approved by: Signed by: Trent Prall Date: 2/21/2025
F686952B4D3949E
 Trent Prall, Engineering & Transportation Director

Contractor: **CC Enterprises - Traffic Control Specialists, Inc.**

Signature: Signed by: Jeff York Date: 2/24/2025
A7750FE77682407
 Name and Title: Jeff York, Project Manager



CC Enterprises
Traffic Control Specialists, Inc.
 830 21½ Road • Grand Junction, Colorado 81505
 Phone: (970) 242-0669 • Fax: (970) 242-0530

PROJECT BID CMO 01

WDBE CERTIFIED

OWNER: CITY OF GRAND JUNCTION CONTACT: EVAN
 PROJECT NAME: PARKS PEDESTRIAN LIGHTING IMPROVEMENTS DATE: 2/20/2025
 PROJECT NUMBER: IFB 5521-24-DD

| DESCRIPTION | UNITS | ESTIMATED QUANTITY | PRICE | AMOUNT |
|--|-------|--------------------|----------|------------------|
| TYPE TWO PULL BOX ELECTRIC | EA | 2 | 675.00 | 1,350.00 |
| WIRING | LS | 1 | 5,800.00 | 5,800.00 |
| PHILIPS GULLWING LED GL18-SB | EA | 2 | 7,500.00 | 15,000.00 |
| LIGHT STANDARD FOUNDATION SPECIAL PARKING AREA | EA | 2 | 1,450.00 | 2,900.00 |
| DIM AND SENSOR SWITHES | EA | 4 | 1,800.00 | 7,200.00 |
| TOTAL BID: | | | | <u>32,250.00</u> |

NOTES:

1. PRICE FOR ADDING ADDITIONAL LIGHTING WITH DIM CAPABILITIES AT VOLLEYBALL PIT.
2. INCLUDES ALL MATERIALS, LABOR AND INSTALLATION.

QUOTED BY: JEFF YORK AFTER HOURS PHONE: 970 261-2484

CONTRACTOR AGREES TO PAY CC ENTERPRISES WITHIN THIRTY (30) DAYS AFTER RECEIPT OF INVOICE WITH THE FOLLOWING EXCEPTIONS:

1. CONTRACTED PROJECT PAYMENT TERMS ARE AGREED UPON PER EACH INDIVIDUAL CONTRACT/QUOTE.
2. COLORADO DEPARTMENT OF TRANSPORTATION (CDOT) PROJECT PAYMENT TERMS ARE WITHIN SEVEN (7) DAYS FROM PRIME CONTRACTOR RECEIPT OF PAYMENT FROM CDOT.

INTEREST WILL ACCRUE AT RATE OF FIFTEEN (15) PERCENT PER ANNUM ON PAYMENTS NOT MADE IN A TIMELY MANNER. IF IT BECOMES NECESSARY FOR CC ENTERPRISES TO INCUR COLLECTION COSTS FOR ANY AMOUNT DUE UNDER THIS AGREEMENT, THE UNDERSIGNED PROMISES TO PAY ADDITIONAL COLLECTION COSTS INCLUDING REASONABLE ATTORNEY FEES AND COURT COSTS.

CONTRACTOR SIGNATURE: _____

PLEASE FAX OR RETURN SIGNED FORM TO OUR OFFICE UPON ACCEPTANCE

QUOTE VALID FOR 90 DAYS

QUOTE: 11204



Gullwing LED

GL18 Large



Gardco Gullwing LED luminaires combine LED performance excellence and advanced Gardco LED thermal management technology with the distinct Gullwing style to provide outdoor area lighting that is both energy efficient and aesthetically pleasing.

Project: GJ PARKS
 Location: COLUMBINE PARK
 Cat.No: GL18-APD-MRI-4-310LA-961A-NW-UNV-BLP-LF
 Type: SB
 Lamps: Qty:
 Notes: REVISED FOR CHANGE ORDER

Ordering guide

Example: GL18-APD-4-80LA-4853-NW-120-BRP-LF

| Prefix | Controls | Mounting | Optical System ⁶ | Wattage | LED Color | Voltage | Finish | Options |
|---|--|---|---|--|---|--|--|---|
| GL18 | APD-MRI | -- | 4 | 310LA-961A | NW | UNV | BLP | LF-IS-RPA2 |
| GL18 18" Gullwing LED Luminaire | — Gullwing Standard Luminaire DIM 0-10V Dimming APD ¹ Automatic Profile Dimming MRI ¹ Motion Response at 50% Low (luminaire mounted sensor) APD-MRI ¹ APD with Motion Response Override (luminaire mounted sensor) FAWS ³ Field Adjustable Wattage Selector | -- Arm Mount (Standard, for square pole) W Wall Mount, Recessed J-Box (must order as separate line item) WS Wall Mount, Surface Conduit (must order as separate line item) | 2 Type 2 2-90 Type 2@90° 2-270 Type 2@270° 3 Type 3 3-90 Type 3@90° 3-270 Type 3@270° 4 Type 4 4-90 Type 4@90° 4-270 Type 4@270° 5 Type 5 | 50LA-4835 48 LEDs, 350mA 80LA-4853 48 LEDs, 530mA 105LA-4870 48 LEDs, 700mA 160LA-481A 48 LEDs, 1A 180LA-6490 64 LEDs, 900mA 210LA-641A 64 LEDs, 1A 200LA-9670 96 LEDs, 700mA 230LA-9680 96 LEDs, 800mA 265LA-9690 96 LEDs, 900 mA 310LA-961A 96 LEDs, 1A | NW Neutral White 4000K, 70 min. CRI CW Cool White 5000K, 70 min. CRI WW Warm White 3000K, 70 min. CRI | 120 208 240 277 347 480 UNV (120-277V) HVU (347-480V) | BLP Black Paint WP White Paint BRP Bronze Paint NP Natural Aluminum Paint OC Optional Color Specify optional color or RAL ex: OC-LGP or OC-RAL7024. SC Special Color Specify. Must supply color chip. Requires factory quote. | LF ⁹ In-Line/In-Pole Fusing PC ^{4,5,9} Photocontrol and Receptacle (Includes PCR5) PCR7 ^{4,5,6} Photocell Receptacle only with 2 dimming and 2 auxiliary connections IS Internal Houseside Shield (types 2, 3, 4 only) RPA1 ⁸ 3" Round Pole Adapter Required for 3" O.D. round or tapered round poles where top O.D. is less than 4" RPA2 ⁸ 4" and 5" Round Pole Adapter Required for 4"- 5" O.D. round poles PTF2 ⁷ Pole Top Fitter 2 3/8" - 3" Dia. Tenon PTF3 ⁷ Pole Top Fitter 3" - 3 1/2" Dia. Tenon PTF4 ⁷ Pole Top Fitter 3 1/2" - 4" Dia. Tenon |

1. Available 120-277V only.
 2. Available 120 or 277V only.
 3. Not available with other control options.
 4. Not available in 480V.
 5. If ordered with DIM, APD, MRI, APD-MRI, dimming will not be connected to NEMA receptacle.

6. Works with 3-pin or 5-pin NEMA photocell/dimming device and auxiliary connections are not connected (for future use only).
 7. Not available in 120° mounting configurations.
 8. Ordered separately as an accessory.
 9. Must specify voltage.



GL18 Gullwing LED area luminaire, large

Site and Area

Ordering guide

| Prefix | Controls | Optical System ^o | Wattage | LED Color | Voltage | Finish | Options |
|---|---|--|--|---|--|--|---|
| GL18-RK 18" Gullwing LED Retrofit Kit | DIM with 0-10v Dimming APD ¹ with Automatic Profile Dimming | 2 Type 2 2-90 Type 2@90° 2-270 Type 2@270° 3 Type 3 3-90 Type 3@90° 3-270 Type 3@270° 4 Type 4 4-90 Type 4@90° 4-270 Type 4@270° 5 Type 5 | 50LA-4835 48 LEDs, 350mA 80LA-4853 48 LEDs, 530mA 105LA-4870 48 LEDs, 700mA 160LA-481A 48 LEDs, 1A 180LA-6490 64 LEDs, 900mA 210LA-641A 64 LEDs, 1A 200LA-9670 96 LEDs, 700mA 230LA-9680 96 LEDs, 800mA 265LA-9690 96 LEDs, 900 mA 310LA-961A 96 LEDs, 1A | NW Neutral White 4000K, 70 min. CRI CW Cool White 5000K, 70 min. CRI WW Warm White 3000K, 70 min. CRI | 120 208 240 277 347 480 UNV (120-277V) HVU (347-480V) | BLP Black Paint WP White Paint BRP Bronze Paint NP Natural Aluminum Paint OC Optional Color Specify optional color or RAL ex: OC-LGP or OC-RAL7024. SC Special Color Specify. Must supply color chip. Requires factory quote. | IS Internal Houseside Shield (types 2, 3, 4 only) |

1. Available 120-277V only.

Dimensions and EPA

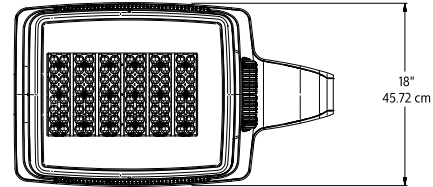
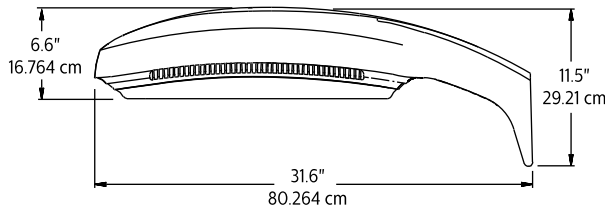

EPA Data

| 1 | 2 | 3-4 |
|---------------------|---------------------|---------------------|
| 1.2 ft ² | 2.4 ft ² | 3.2 ft ² |
| .12 m ² | .24 m ² | .30 m ² |

Approximate Weight Single Luminaire

40 lbs / 18.144 kg

GL18 Drill Template

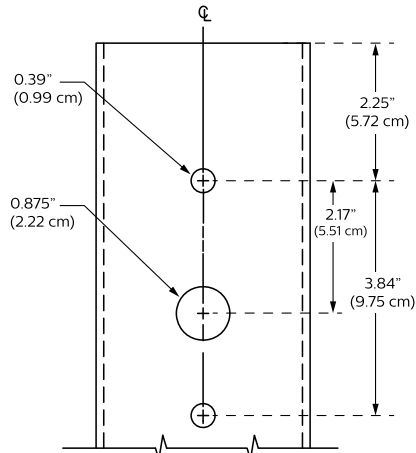

GL18 Gullwing LED area luminaire, large

Site and Area

GL18-RK LED Retrofit Kit

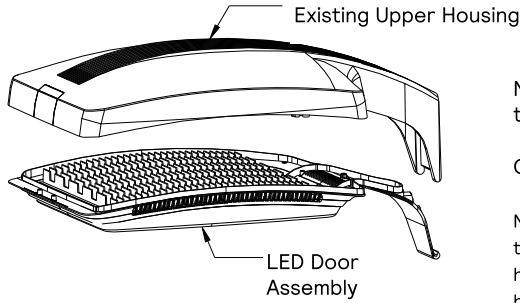

Note: Removal of all components of existing G18 Gullwing luminaires, except the upper housing, is required to perform a retrofit.

GL18-RK includes all necessary retrofit components.

Note: TGIC polyester powdercoat will fade somewhat in exterior environments over time. Once the retrofit kit is installed, there is a possibility that the upper housing may have faded to a point where there is a noticeable paint difference between the upper housing (existing) and the new retrofit kit door frame.

LED Wattage and Lumen Value - 3000K

| Ordering Code | LED QTY | System Current (mA) | Average System Watts | Color Temp. | Type 2 | | | Type 3 | | |
|----------------------|---------|---------------------|----------------------|-------------|--------------|-----------------|------------|--------------|-----------------|------------|
| | | | | | Lumen Output | Efficacy (Lm/W) | BUG Rating | Lumen Output | Efficacy (Lm/W) | BUG Rating |
| GL18-x-50LA-4835-WW | 48 | 350 | 50 | 3000K | 6638 | 133 | B2-U0-G1 | 6106 | 122 | B1-U0-G2 |
| GL18-x-80LA-4853-WW | 48 | 530 | 80 | 3000K | 9570 | 120 | B2-U0-G1 | 8802 | 110 | B2-U0-G2 |
| GL18-x-105LA-4870-WW | 48 | 700 | 105 | 3000K | 12139 | 116 | B3-U0-G2 | 11171 | 106 | B2-U0-G2 |
| GL18-x-160LA-481A-WW | 48 | 1050 | 160 | 3000K | 16471 | 103 | B3-U0-G2 | 15142 | 94 | B2-U0-G3 |
| GL18-x-180LA-6490-WW | 64 | 900 | 180 | 3000K | 19022 | 106 | B3-U0-G2 | 17846 | 99 | B3-U0-G3 |
| GL18-x-210LA-641A-WW | 64 | 1050 | 208 | 3000K | 21349 | 102 | B3-U0-G2 | 20016 | 96 | B3-U0-G3 |
| GL18-x-200LA-9670-WW | 96 | 700 | 200 | 3000K | 23713 | 119 | B3-U0-G2 | 21704 | 109 | B3-U0-G3 |
| GL18-x-230LA-9680-WW | 96 | 800 | 230 | 3000K | 26191 | 114 | B3-U0-G2 | 23986 | 104 | B3-U0-G4 |
| GL18-x-265LA-9690-WW | 96 | 900 | 265 | 3000K | 28669 | 108 | B4-U0-G3 | 26246 | 99 | B3-U0-G4 |
| GL18-x-310LA-961A-WW | 96 | 1050 | 309 | 3000K | 31366 | 101 | B4-U0-G3 | 28705 | 93 | B3-U0-G4 |
| Ordering Code | LED QTY | System Current (mA) | Average System Watts | Color Temp. | Type 4 | | | Type 5 | | |
| | | | | | Lumen Output | Efficacy (Lm/W) | BUG Rating | Lumen Output | Efficacy (Lm/W) | BUG Rating |
| GL18-x-50LA-4835-WW | 48 | 350 | 50 | 3000K | 6300 | 126 | B1-U0-G2 | 6628 | 133 | B3-U0-G1 |
| GL18-x-80LA-4853-WW | 48 | 530 | 80 | 3000K | 9083 | 114 | B2-U0-G2 | 9555 | 119 | B3-U0-G2 |
| GL18-x-105LA-4870-WW | 48 | 700 | 105 | 3000K | 11521 | 110 | B2-U0-G2 | 12121 | 115 | B4-U0-G2 |
| GL18-x-160LA-481A-WW | 48 | 1050 | 160 | 3000K | 15633 | 98 | B2-U0-G3 | 16446 | 103 | B4-U0-G2 |
| GL18-x-180LA-6490-WW | 64 | 900 | 180 | 3000K | 17943 | 100 | B3-U0-G3 | 19213 | 107 | B4-U0-G2 |
| GL18-x-210LA-641A-WW | 64 | 1050 | 208 | 3000K | 20139 | 97 | B3-U0-G4 | 21564 | 104 | B4-U0-G2 |
| GL18-x-200LA-9670-WW | 96 | 700 | 200 | 3000K | 22136 | 111 | B3-U0-G4 | 23847 | 119 | B5-U0-G3 |
| GL18-x-230LA-9680-WW | 96 | 800 | 230 | 3000K | 24449 | 106 | B3-U0-G4 | 26339 | 115 | B5-U0-G3 |
| GL18-x-265LA-9690-WW | 96 | 900 | 265 | 3000K | 26762 | 101 | B3-U0-G4 | 28830 | 109 | B5-U0-G3 |
| GL18-x-310LA-961A-WW | 96 | 1050 | 309 | 3000K | 29280 | 95 | B3-U0-G4 | 31543 | 102 | B5-U0-G3 |
| Ordering Code | LED QTY | System Current (mA) | Average System Watts | Color Temp. | Type 2 | | | Type 3 | | |
| | | | | | Lumen Output | Efficacy (Lm/W) | BUG Rating | Lumen Output | Efficacy (Lm/W) | BUG Rating |
| GL18-x-50LA-4835-NW | 48 | 350 | 50 | 4000K | 7376 | 148 | B2-U0-G1 | 6784 | 136 | B1-U0-G2 |
| GL18-x-80LA-4853-NW | 48 | 530 | 80 | 4000K | 10,633 | 133 | B2-U0-G2 | 9780 | 122 | B2-U0-G2 |
| GL18-x-105LA-4870-NW | 48 | 700 | 105 | 4000K | 13,488 | 128 | B3-U0-G2 | 12412 | 118 | B2-U0-G2 |
| GL18-x-160LA-481A-NW | 48 | 1050 | 160 | 4000K | 18,302 | 114 | B3-U0-G2 | 16824 | 105 | B3-U0-G3 |
| GL18-x-180LA-6490-NW | 64 | 900 | 180 | 4000K | 21,135 | 117 | B3-U0-G2 | 19829 | 110 | B3-U0-G3 |
| GL18-x-210LA-641A-NW | 64 | 1050 | 208 | 4000K | 23,721 | 114 | B3-U0-G2 | 22240 | 107 | B3-U0-G4 |
| GL18-x-200LA-9670-NW | 96 | 700 | 200 | 4000K | 26,347 | 132 | B3-U0-G2 | 24115 | 121 | B3-U0-G4 |
| GL18-x-230LA-9680-NW | 96 | 800 | 230 | 4000K | 29,101 | 127 | B4-U0-G3 | 26651 | 116 | B3-U0-G4 |
| GL18-x-265LA-9690-NW | 96 | 900 | 265 | 4000K | 31,854 | 120 | B4-U0-G3 | 29162 | 110 | B3-U0-G4 |
| GL18-x-310LA-961A-NW | 96 | 1050 | 309 | 4000K | 34,851 | 113 | B4-U0-G3 | 31894 | 103 | B3-U0-G4 |

GL18 Gullwing LED area luminaire, large

Site and Area

LED Wattage and Lumen Value - 4000K (continued)

| Ordering Code | LED QTY | System Current (mA) | Average System Watts | Color Temp. | Type 4 | | | Type 5 | | |
|----------------------|---------|---------------------|----------------------|-------------|--------------|-----------------|------------|--------------|-----------------|------------|
| | | | | | Lumen Output | Efficacy (Lm/W) | BUG Rating | Lumen Output | Efficacy (Lm/W) | BUG Rating |
| GL18-x-50LA-4835-NW | 48 | 350 | 50 | 4000K | 7000 | 140 | B1-U0-G2 | 7364 | 147 | B3-U0-G1 |
| GL18-x-80LA-4853-NW | 48 | 530 | 80 | 4000K | 10092 | 126 | B2-U0-G2 | 10617 | 133 | B4-U0-G2 |
| GL18-x-105LA-4870-NW | 48 | 700 | 105 | 4000K | 12802 | 122 | B2-U0-G2 | 13467 | 128 | B4-U0-G2 |
| GL18-x-160LA-481A-NW | 48 | 1050 | 160 | 4000K | 17370 | 108 | B3-U0-G3 | 18273 | 114 | B4-U0-G2 |
| GL18-x-180LA-6490-NW | 64 | 900 | 180 | 4000K | 19937 | 111 | B3-U0-G3 | 21348 | 119 | B4-U0-G2 |
| GL18-x-210LA-641A-NW | 64 | 1050 | 208 | 4000K | 22376 | 107 | B3-U0-G4 | 23960 | 115 | B5-U0-G3 |
| GL18-x-200LA-9670-NW | 96 | 700 | 200 | 4000K | 24595 | 123 | B3-U0-G4 | 26496 | 132 | B5-U0-G3 |
| GL18-x-230LA-9680-NW | 96 | 800 | 230 | 4000K | 27165 | 118 | B3-U0-G4 | 29265 | 127 | B5-U0-G3 |
| GL18-x-265LA-9690-NW | 96 | 900 | 265 | 4000K | 29735 | 112 | B3-U0-G4 | 32034 | 121 | B5-U0-G3 |
| GL18-x-310LA-961A-NW | 96 | 1050 | 309 | 4000K | 32533 | 105 | B3-U0-G4 | 35048 | 113 | B5-U0-G4 |

| Ordering Code | LED QTY | System Current (mA) | Average System Watts | Color Temp. | Type 2 | | | Type 3 | | |
|----------------------|---------|---------------------|----------------------|-------------|--------------|-----------------|------------|--------------|-----------------|------------|
| | | | | | Lumen Output | Efficacy (Lm/W) | BUG Rating | Lumen Output | Efficacy (Lm/W) | BUG Rating |
| GL18-x-50LA-4835-CW | 48 | 350 | 50 | 5000K | 6638 | 133 | B2-U0-G1 | 6106 | 122 | B1-U0-G2 |
| GL18-x-80LA-4853-CW | 48 | 530 | 80 | 5000K | 9570 | 120 | B2-U0-G1 | 8802 | 110 | B2-U0-G2 |
| GL18-x-105LA-4870-CW | 48 | 700 | 105 | 5000K | 12139 | 116 | B3-U0-G2 | 11171 | 106 | B2-U0-G2 |
| GL18-x-160LA-481A-CW | 48 | 1050 | 160 | 5000K | 16471 | 103 | B3-U0-G2 | 15142 | 94 | B2-U0-G3 |
| GL18-x-180LA-6490-CW | 64 | 900 | 180 | 5000K | 19022 | 106 | B3-U0-G2 | 17846 | 99 | B3-U0-G3 |
| GL18-x-210LA-641A-CW | 64 | 1050 | 208 | 5000K | 21349 | 102 | B3-U0-G2 | 20016 | 96 | B3-U0-G3 |
| GL18-x-200LA-9670-CW | 96 | 700 | 200 | 5000K | 23713 | 119 | B3-U0-G2 | 21704 | 109 | B3-U0-G3 |
| GL18-x-230LA-9680-CW | 96 | 800 | 230 | 5000K | 26191 | 114 | B3-U0-G2 | 23986 | 104 | B3-U0-G4 |
| GL18-x-265LA-9690-CW | 96 | 900 | 265 | 5000K | 28669 | 108 | B4-U0-G3 | 26246 | 99 | B3-U0-G4 |
| GL18-x-310LA-961A-CW | 96 | 1050 | 309 | 5000K | 31366 | 101 | B4-U0-G3 | 28705 | 93 | B3-U0-G4 |

| Ordering Code | LED QTY | System Current (mA) | Average System Watts | Color Temp. | Type 4 | | | Type 5 | | |
|----------------------|---------|---------------------|----------------------|-------------|--------------|-----------------|------------|--------------|-----------------|------------|
| | | | | | Lumen Output | Efficacy (Lm/W) | BUG Rating | Lumen Output | Efficacy (Lm/W) | BUG Rating |
| GL18-x-50LA-4835-CW | 48 | 350 | 50 | 5000K | 6300 | 126 | B1-U0-G2 | 6628 | 133 | B3-U0-G1 |
| GL18-x-80LA-4853-CW | 48 | 530 | 80 | 5000K | 9083 | 114 | B2-U0-G2 | 9555 | 119 | B3-U0-G2 |
| GL18-x-105LA-4870-CW | 48 | 700 | 105 | 5000K | 11521 | 110 | B2-U0-G2 | 12121 | 115 | B4-U0-G2 |
| GL18-x-160LA-481A-CW | 48 | 1050 | 160 | 5000K | 15633 | 98 | B2-U0-G3 | 16446 | 103 | B4-U0-G2 |
| GL18-x-180LA-6490-CW | 64 | 900 | 180 | 5000K | 17943 | 100 | B3-U0-G3 | 19213 | 107 | B4-U0-G2 |
| GL18-x-210LA-641A-CW | 64 | 1050 | 208 | 5000K | 20139 | 97 | B3-U0-G4 | 21564 | 104 | B4-U0-G2 |
| GL18-x-200LA-9670-CW | 96 | 700 | 200 | 5000K | 22136 | 111 | B3-U0-G4 | 23847 | 119 | B5-U0-G3 |
| GL18-x-230LA-9680-CW | 96 | 800 | 230 | 5000K | 24449 | 106 | B3-U0-G4 | 26339 | 115 | B5-U0-G3 |
| GL18-x-265LA-9690-CW | 96 | 900 | 265 | 5000K | 26762 | 101 | B3-U0-G4 | 28830 | 109 | B5-U0-G3 |
| GL18-x-310LA-961A-CW | 96 | 1050 | 309 | 5000K | 29280 | 95 | B3-U0-G4 | 31543 | 102 | B5-U0-G3 |

Values from photometric tests performed in accordance with IESNA LM-79 and are representative of the configurations shown. Actual performance may vary due to installation and environmental variables, LED and driver tolerances, and field measurement considerations. It is highly recommended to confirm performance with a photometric layout.

NOTE: Some data may be scaled based on tests of similar (but not identical) luminaires. Contact factory for configurations not shown.

Predicted lumen depreciation data:

| Ambient Temperature °C | Driver mA | Calculated L ₇₀ Hours | L ₇₀ Per TM-21 | Lumen Maintenance % @ 60,000 hours |
|------------------------|---------------|----------------------------------|---------------------------|------------------------------------|
| 25°C | up to 1050 mA | >100,000 | >60,000 | 96% |

Predicted performance derived from LED manufacturer's data and engineering design estimates, based on IESNA LM-80 methodology. Actual experience may vary due to field application conditions. L70 is the predicted time when LED performance depreciates to 70% of initial lumen output. Calculated per IESNA TM21-11. Published L70 hours limited to 6 times actual LED test hours

GL18 Gullwing LED area luminaire, large

Site and Area

Asymmetric Optical Orientation Information

Standard Optic Position

Luminaires ordered with asymmetric optical systems in the standard optic position will have the optical system oriented as shown below:

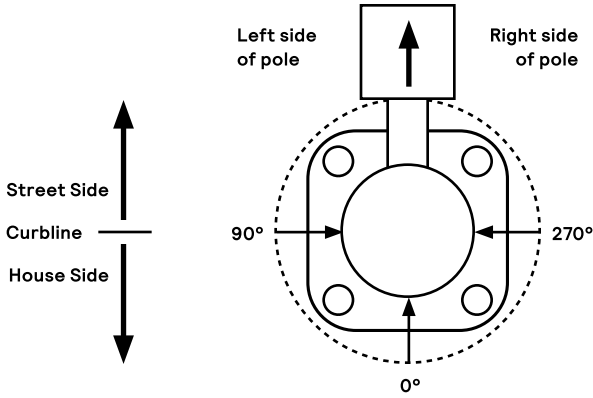

Note: The hand hole will normally be located on the pole at the 0° point.

Optic Rotated Left (90°) Optic Position

Luminaires ordered with asymmetric optical systems in the Optic Rotated Left (90°) optic position will have the optical system oriented as shown below:

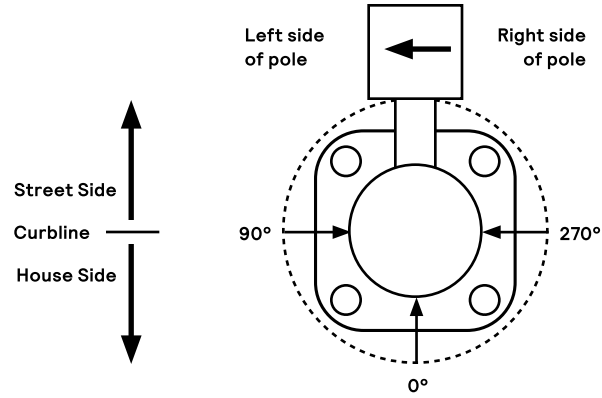

Note: The hand hole will normally be located on the pole at the 0° point.

Asymmetric Optical Orientation Information

Optic Rotated Right (270°) Optic Position:

Luminaires ordered with asymmetric optical systems in the Optic Rotated Right (270°) optic position will have the optical system oriented as shown below:

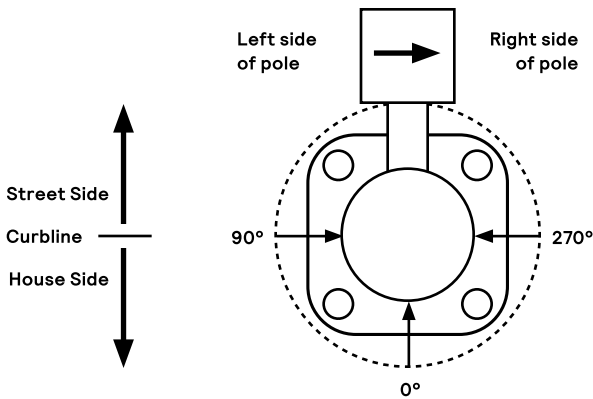

Note: The hand hole will normally be located on the pole at the 0° point.

Twin Luminaire Assemblies With Rotated Optical Systems

Twin luminaire assemblies installed with rotated optical systems are an excellent way to direct light toward the interior of the site (Street Side) without additional equipment. It is important, however, that care be exercised to insure that luminaires are installed in the proper location.

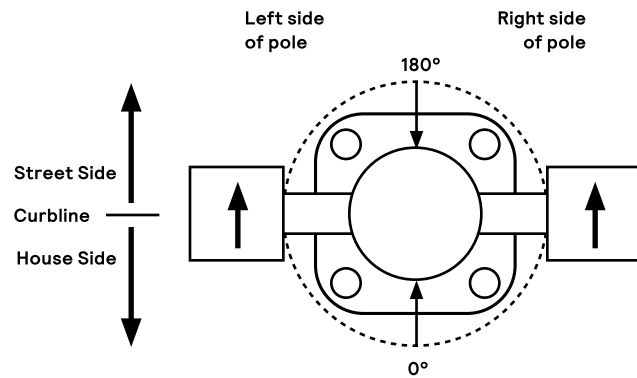

Luminaires with Optic Rotated Right (270°) are installed on the LEFT Side of Pole

Luminaires with Optic Rotated Left (90°) are installed on the RIGHT Side of Pole

Note: The hand hole location will depend on the drilling configuration ordered for the pole.

GL18 Gullwing LED area luminaire, large

Site and Area

Specifications

General Description

The Gardco Gullwing LED is defined by its high performance, sleek profile and rugged construction. Gullwing LED luminaires combine LED performance excellence and advanced Gardco LED thermal management technology with the distinct Gullwing style to provide outdoor area lighting that is both energy efficient and aesthetically pleasing.

Housing

A one-piece die cast aluminum housing mounts directly to a pole or wall without the need for a support arm. The low profile rounded form reduces the effective projected area of the luminaire to only 1.2 ft² / .12 m².

IP Rating

Gullwing LED 18" optics are IP66 rated.

Thermal Management

The Gardco Gullwing LED provides a one piece die cast aluminum door with integral thermal radiation fins combined with lateral air ways, to provide the excellent thermal management so critical to long LED system life. GL18 is UL listed from -40 to 40°C ambient.

LED Optical System

LED arrays are set to achieve IES Type II, Type III, Type IV, Type V, available with internal shields for back light control. Type 2, 3, 4 optics can be factory set to 90 or 270° orientations. Individual LED arrays are replaceable. Luminaires feature high performance Class 1 LED systems.

GL18

Gardco Gullwing LED standard luminaire providing constant wattage and constant light output when power to the luminaire is energized.

GL18-DIM

Gardco Gullwing LED luminaire provided with 0-10V dimming for connection to a control system provided by others.

GL18-APD

Gardco Gullwing LED luminaire with Automatic Profile Dimming. Luminaire is provided with a programmable LED Driver, programmed to go to 50% power, 50% light output two (2) hours prior to night time mid-point and remain at 50% for six (6) hours after night time mid-point. Mid-point is continuously recalculated by the programmable LED Driver based on the average mid-point of the last two full night cycles. Short duration cycles, and power interruptions are ignored and do not affect the determination of mid-point.

GL18-APD Dimming Profile:

| | | | |
|------|---------|---------|------|
| 100% | 2 hours | 6 hours | 100% |
| | 50% | 50% | |

Power On Mid Point Power Off

The GL18-APD offers many of the advantages of a sophisticated control system, including an average energy savings of at least 33% versus constant wattage, constant light output systems, without the need for a control system.

GL18-MRI (Luminaire mounted sensor)

Luminaires with Motion Response and an integral

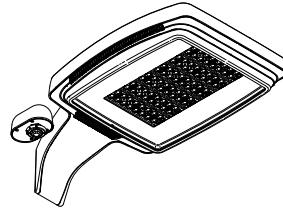

motion sensor include a programmable LED driver and an outboarded programmable motion sensor attached to the luminaire arm. The motion sensor is set to a constant 50%. When motion is detected, the luminaire goes to 100%. The luminaire remains on high until no motion is detected for the motion sensor duration period, after which the luminaire returns to low. Duration period is factory set at 5 minutes. Available from 120V to 277V (UNIV) only.

The approximate motion sensor coverage pattern is as shown below.

Side Coverage Pattern

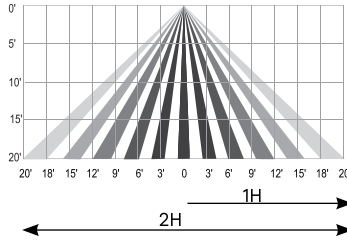

Top Coverage Pattern

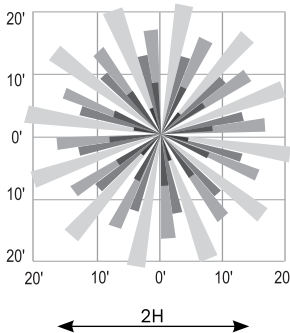

Distances are approximate.
H = height above ground

GL18-APD- MRI (Luminaire mounted sensor)

Luminaires with Integral Motion Sensor - GL18-APD- MRI: Luminaires with Automatic Profile Dimming and Motion Response Override combine the benefits of both automatic profile dimming and motion response. APD-MRI luminaires utilize a programmable LED driver. The luminaire will dim to 50% power, 50% light output, per the dimming profile shown for APD luminaires (see page 4). If motion is detected during the time that the luminaire is operating at 50%, the luminaire goes to 100% power and light output. The luminaire remains on high until no motion is detected for the duration period, after which the luminaire returns to low. Duration period is factory set at 15 minutes.

APD-MRI luminaires are available from 120V to 277V (UNIV) input voltages only.

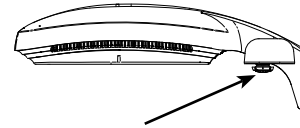

Approximate Sensor Placement on GL18-MRI and GL18-APD-MRI luminaires.

Sensor - Bottom View

Field Adjustable Wattage Selector (FAWS): Luminaire equipped with the ability to manually adjust the wattage in the field to reduce total luminaire lumen output and light levels. Comes pre-set to the highest position at the lumen output selected. Use chart below to estimate reduction in lumen output desired. Cannot be used with other control options or motion response.

| FAWS Position | Percentage of Typical Lumen Output |
|---------------|------------------------------------|
| 1 | 25% |
| 2 | 50% |
| 3 | 55% |
| 4 | 65% |
| 5 | 75% |
| 6 | 80% |
| 7 | 85% |
| 8 | 90% |
| 9 | 95% |
| 10 | 100% |

GL18 Gullwing LED area luminaire, large

Site and Area

Electrical

Luminaires are equipped with an LED driver that accepts 120V through 277V, or 347V through 480V, 50hz to 60hz, input. Driver output is based on the LED wattage selected. Component-to-component wiring within the luminaire will carry no more than 80% of rated current and is listed by UL. Power factor is not less than 90%. Luminaire consumes 0.0 watts in the off state. All motion sensors utilized consume 0.0 watts in the off state. Surge protector standard. 10KA per ANSI/IEEE C62.41.2.

Finish

Each standard color luminaire receives a fade and abrasion resistant, electrostatically applied, thermally cured, triglycidal isocyanurate (TGIC) textured polyester powdercoat finish. Standard colors include bronze (BRP), black (BLP), white (WP), and 5 natural aluminum (NP). Consult factory for specs on optional or custom colors.

Labels

All luminaires bear UL or CUL (where applicable) Wet Location labels. Most GL18 configurations are qualified under Standard DesignLights Consortium® category. Consult DLC Qualified Products list to confirm your specific luminaire selection is approved.

Warranty

Gardco luminaires feature a 5 year limited warranty. Gardco LED luminaires with LED arrays feature a 5 year limited warranty covering the LED arrays. LED Drivers also carry a 5 year limited warranty. Motion sensors are covered by warranty for 5 years by the motion sensor manufacturer. See [signify.com/warranties](https://www.signify.com/warranties) for complete details and exclusions.



CITY OF GRAND JUNCTION, COLORADO

CONTRACT

This CONTRACT made and entered into this 30th day of December, 2024 by and between the City of Grand Junction, Colorado, a government entity in the County of Mesa, State of Colorado, hereinafter in the Contract Documents referred to as the "Owner" and CC Enterprises – Traffic Control Specialists, Inc. hereinafter in the Contract Documents referred to as the "Contractor."

WITNESSETH:

WHEREAS, the Owner advertised that sealed Responses would be received for furnishing all labor, tools, supplies, equipment, materials, and everything necessary and required for the Project described by the Contract Documents and known as Parks Pedestrian Lighting Improvements IFB-5521-24-DD.

WHEREAS, the Contract has been awarded to the above-named Contractor by the Owner, and said Contractor is now ready, willing, and able to perform the Work specified in the Notice of Award, in accordance with the Contract Documents.

NOW, THEREFORE, in consideration of the compensation to be paid the Contractor, the mutual covenants hereinafter set forth and subject to the terms hereinafter stated, it is mutually covenanted and agreed as follows:

ARTICLE 1

Contract Documents: It is agreed by the parties hereto that the following list of instruments, drawings, and documents which are attached hereto, bound herewith, or incorporated herein by reference constitute and shall be referred to either as the "Contract Documents" or the "Contract", and all of said instruments, drawings, and documents taken together as a whole constitute the Contract between the parties hereto, and they are fully a part of this agreement as if they were set out verbatim and in full herein:

The order of contract document governance shall be as follows:

- The body of this Contract Agreement
- Solicitation Documents for the Project; **Parks Pedestrian Lighting Improvements IFB-5521-24-DD**
- Notice of Award
- Contractor's Response to the Solicitation
- Work Change Requests (directing that changed work be performed);
- Field Orders;
- Change Orders.

ARTICLE 2

Definitions: The clauses provided in the Solicitation apply to the terms used in the Contract and all the Contract Documents.

ARTICLE 3

Contract Work: The Contractor agrees to furnish all labor, tools, supplies, equipment, materials, and all that is necessary and required to complete the tasks associated with the Work described, set forth, shown, and included in the Contract Documents as indicated in the Solicitation Document.

ARTICLE 4

Contract Time and Liquidated Damages: Time is of the essence with respect to this Contract. The Contractor hereby agrees to commence Work under the Contract on or before the date specified in the Solicitation from the Owner, and to achieve Substantial Completion and Final Completion of the Work within the time or times specified in the Solicitation. In the event the Work is not completed in the times set forth and as agreed upon, the Contractor further agrees to pay Liquidated Damages to the Owner as set forth in the Solicitation. The Contractor acknowledges and recognizes the delays, expenses and difficulties involved in proving in a legal proceeding the actual losses suffered by the Owner if the work is not completed on time. Accordingly, instead of requiring any such proof, the Owner and the Contractor agree that as Liquidated Damages for delay, but not as a penalty, the Contractor shall pay to the Owner the amounts specified in the Solicitation.

ARTICLE 5

Contract Price and Payment Procedures: The Contractor shall accept as full and complete compensation for the performance and completion of all of the Work specified in the Contract Documents, the sum of **Four Hundred, Five Thousand, Three Hundred, Twenty-Six and 50/100 Dollars (\$405,326.50) for Option 2 inclusive of Columbine, Hawthorne, and Sherwood Parks**. If this Contract contains unit price pay items, the Contract price shall be adjusted in accordance with the actual quantities of items completed and accepted by the Owner at the unit prices quoted in the Solicitation Response. The amount of the Contract Price is and has heretofore been appropriated by the Grand Junction City Council for the use and benefit of this Project. The Contract Price shall not be modified except by Change Order or other written directive of the Owner. The Owner shall not issue a Change Order or other written directive which requires additional work to be performed, which work causes the aggregate amount payable under this Contract to exceed the amount appropriated for this Project, unless and until the Owner provides Contractor written assurance that lawful appropriations to cover the costs of the additional work have been made.

Unless otherwise provided in the Solicitation, monthly partial payments shall be made as the Work progresses. Applications for partial and Final Payment shall be prepared by the Contractor and approved by the Owner in accordance with the Solicitation.

Upon Final Completion of the Work under the Contract and before the Contractor shall receive final payment, the Owner shall publish at least twice in a newspaper of general circulation published in the County a notice that: 1. the Owner has accepted such Work as completed according to the Contract Documents; 2. the Contractor is entitled to final

payment therefore; 3. Thirty (30) days after the first publication, specifying the exact date, the Owner shall pay the full balance due under the Contract; and 4. persons having claims for labor, materials, team hire, sustenance, provisions, provender, or other supplies used or consumed by the Contractor or a subcontractor shall file a verified statement of the amount due and unpaid on account of such claim prior to the date specified for such payment. Nothing herein shall be construed as relieving the Contractor and the Sureties on the Contractor's Bonds from any claim or claims for work or labor done or materials or supplies furnished in the execution of the Contract.

ARTICLE 6

Bonds: The Contractor shall furnish currently herewith the Bonds required by the Contract Documents; such Bonds being attached hereto. The Performance Bond shall be in an amount not less than one hundred percent (100%) of the Contract Price set forth in Article 5. The Payment Bond shall be in an amount not less than one hundred percent (100%) of the Contract Price set forth in Article 5.

ARTICLE 7

Contract Binding: The Owner and the Contractor each bind itself, its partners, successors, assigns and legal representatives to the other party hereto in respect to all covenants, agreements and obligations contained in the Contract Documents. The Contract Documents constitute the entire agreement between the Owner and Contractor and may only be altered, amended, or repealed by a duly executed written instrument. Neither the Owner nor the Contractor shall, without the prior written consent of the other, assign or sublet in whole or in part its interest under any of the Contract Documents and specifically, the Contractor shall not assign any moneys due or to become due without the prior written consent of the Owner.

ARTICLE 8

Severability: If any part, portion or provision of the Contract shall be found or declared null, void or unenforceable for any reason whatsoever by any court of competent jurisdiction or any governmental agency having the authority thereover, only such part, portion or provision shall be affected thereby and all other parts, portions and provisions of the Contract shall remain in full force and effect.

IN WITNESS WHEREOF, City of Grand Junction, Colorado, has caused this Contract to be subscribed and sealed and attested in its behalf; and the Contractor has signed this Contract the day and the year first mentioned herein.

The Contract is executed in two counterparts.

CITY OF GRAND JUNCTION, COLORADO

DocuSigned by:
By: Duane Hoff, Jr., Contract Administrator - City of Grand Junction
Duane Hoff, Jr. Contracts Administrator Date 1/10/2025

CC Enterprises – Traffic Control Specialists Inc.

DocuSigned by:
By: Cindy York
Cindy York, President Date 1/10/2025



Purchasing Division

Invitation for Bid

IFB-5521-24-DD
Parks Pedestrian Lighting Improvements Project

Responses Due:
October 30, 2024, prior to 2:00PM

Accepting Electronic Responses Only
Responses Only Submitted Through the Rocky Mountain E-Purchasing
System (RMEPS)

www.bidnetdirect.com/colorado

(Purchasing Representative does not have access or control of the vendor side of RMEPS. If website or other problems arise during response submission, vendor **MUST** contact RMEPS to resolve issue prior to the response deadline. 800-835-4603)

NOTE: All City solicitation openings will continue to be held
virtually.

Purchasing Representative:
Dolly Daniels, Senior Buyer; Acting as Purchasing Agent
dollyd@gjcity.org
970-256-4048

Invitation for Bids

Table of Contents

Section 1 Instruction to Bidders

Section 2 General Contract Conditions

Section 3 Statement of Work

Section 4 Contractor's Bid Form

Appendix (Click on Links in Section 3.4)

Attachment A: Construction Drawings

Attachment B: Materials Specifications

1. Instructions to Bidders

NOTE: It is the Contractor's responsibility to read and review all solicitation documentation in its entirety, and to ensure that they have a clear and complete understanding of not only the scope, specifications, project requirements, etc., but also all other requirements, instructions, rules, regulations, laws, conditions, statements, procurement policies, etc. that are associated with the solicitation process and project/services being solicited.

- 1.1. A.D.A Document Compliance Requirements:** All work documents, and/or bid/proposal documents submitted, as a result of this Solicitation must comply with all applicable provisions of §§24-85-101, C.R.S., et seq., and the Accessibility Standards for Individuals with a Disability, as established by the Office Of Information Technology according to Section §24-85-103 (2.5), C.R.S. and 3) all State of Colorado technology standards related to technology accessibility and with Level A.A. of the most current version of the Web Content Accessibility Guidelines (WCAG), incorporated in the State of Colorado technology standards.
- 1.2. Required Review:** The Offeror is responsible for thoroughly reviewing all solicitation documentation to gain a comprehensive understanding of the scope, specifications, project requirements, and all associated rules, regulations, laws, conditions, instructions, and procurement policies related to the solicitation process and the Project or Work outlined in this Invitation for Bid (IFB).
- 1.3. Purpose:** The City of Grand Junction is soliciting competitive bids from qualified and interested Contractors for all labor, equipment, and materials required to install park pedestrian lighting upgrades at two City parks and third possible add alternate park. All dimensions and scope of work should be verified by Contractors prior to submission of bids.

IFB Questions:

Dolly Daniels; Purchasing Agent
dollyd@gjcity.org

With the exception of Pre-Bid or Site Visit Meeting(s) all questions, inquiries, comments, or communication pertaining to this Solicitation (whether process, specifications, scope, etc.) must be directed (in writing) to the Purchasing Agent. Other communication may result in disqualification.

- 1.4. Non-Mandatory Pre-Bid Meeting: Prospective bidders are encouraged to attend non-mandatory pre-bid meeting on October 10, 2024, at 10:00AM.** Meeting location shall be at City Hall Auditorium located at 250 N 5th Street, Grand Junction CO 81501. The purpose of this visit will be to inspect and to clarify the contents of this Invitation for Bids (IFB).
- 1.5. The Owner:** The Owner is the City of Grand Junction, Colorado and is referred to throughout this Solicitation. The term Owner means the Owner or his authorized representative.

- 1.6. **Compliance:** All Bidders, by submitting a bid, agree to comply with all conditions, requirements, and instructions of this IFB as stated or implied herein. Should the Owner omit anything which is necessary to clear understanding of the requirements, or should it appear that various instructions are in conflict, the Bidder(s) shall secure instructions from the Purchasing Agent prior to submittal deadline.
- 1.7. **Procurement Process:** The most current version of the City [Purchasing Policy and Procedure Manual](#) is contracting and applies to this Solicitation.
- 1.8. **Submission:** *Each bid shall be submitted in electronic format only, and only through the Rocky Mountain E-Purchasing website (www.bidnetdirect.com/colorado).* *This site offers both “free” and “paying” registration options that allow for full access of the Owner’s documents and for electronic submission of bids.* (Note: “free” registration may take up to 24 hours to process. Please Plan accordingly.) Please view our “**Electronic Vendor Registration Guide**” at <http://www.gjcity.org/business-and-economic-development/bids/> for details. (Purchasing Representative does not have access or control of the vendor side of RMEPS. If website or other problems arise during response submission, vendor **MUST** contact RMEPS to resolve issue prior to the response deadline. **800-835-4603**)

Bid Opening Parks Pedestrian Lighting Improvements

Oct 30, 2024, 2:00 – 2:30 PM (America/Denver)

Please join my meeting from your computer, tablet or smartphone.

<https://meet.goto.com/849783797>

You can also dial in using your phone.

Access Code: 849-783-797

United States: [+1 \(312\) 757-3121](tel:+13127573121)

Join from a video-conferencing room or system.

Meeting ID: 849-783-797

Dial in or type: 67.217.95.2 or inroomlink.goto.com

Or dial directly: 849783797@67.217.95.2 or [67.217.95.2###849783797](tel:67.217.95.2###849783797)

Get the app now and be ready when your first meeting starts:

<https://meet.goto.com/install>

- 1.9. **Modification and Withdrawal of Bids Before Opening.** Bids may be modified or withdrawn by an appropriate document stating such, duly executed and submitted to the place where Bids are to be submitted at any time prior to Bid Opening.
- 1.10. **Form for Price Bid:** All Price Bids must be made upon the Price Bid Schedule attached and state the amounts both in words and in figures and must be signed and acknowledged by the Bidder.
The Bidder shall specify a unit price in figures for each pay item for which a quantity is given and shall provide the products (in numbers) of the respective unit prices and quantities in the Extended Amount column. The total Bid price shall be equal to the sum of all extended amount prices. When an item in the Price Bid Schedule provides a choice to be made by the Bidder, Bidder's choice shall be indicated in accordance with the specifications for that particular item and thereafter no further choice shall be permitted.

Where the unit of a pay item is lump sum, the lump sum amount shall be shown in the "extended amount" column and included in the summation of the total Bid.

All blank spaces in the Price Bid Schedule must be properly filled out.

Bids by Corporations must be executed in the corporate name by the president or vice president, or other business officer accompanied by evidence of authority to sign. The entity address and state of organization of the entity shall be shown below the signature. All names must be typed or printed below the signature.

Bids by partnerships must be executed in the partnership name and signed by a partner whose title must appear under the signature and the official address of the partnership must be shown below the signature.

The Bidder's Bid shall contain an acknowledgement of receipt of all Addenda, the numbers of which shall be filled in on the Contractor's Bid Form.

The contact information to which communications regarding the Bid are to be directed must be shown.

- 1.11. **Exclusions:** No oral, telephonic, emailed, or facsimile bid will be considered
- 1.12. **Contract Documents:** The complete IFB and bidder's response compose the Contract Documents. Copies of bid documents can be obtained from the City Purchasing website, <https://co-grandjunction.civicplus.com/501/Purchasing-Bids> .
- 1.13. **Additional Documents:** The July 2010 edition of the "City Standard Contract Documents for Capital Improvements Construction", Plans, Specifications and other Bid Documents are available for review or download on the Purchasing Bids page at <https://co-grandjunction.civicplus.com/501/Purchasing-Bids>.
- 1.14. **Definitions and Terms:** See Article I, Section 3 of the General Contract Conditions in the *Standard Contract Documents for Capital Improvements Construction*.
- 1.15. **Examination of Specifications:** Bidders shall thoroughly examine and be familiar with the project Statement of Work. The failure or omission of any Offeror to receive or examine any form, addendum, or other document shall in no way relieve any Offeror from any obligation with respect to his bid. The submission of a bid shall be taken as evidence of compliance with this section. Prior to submitting a bid, each Offeror shall, at a minimum:
 - a. Examine the *Contract Documents* thoroughly;
 - b. Visit the site to familiarize themselves with local conditions that may in any manner affect cost, progress, or performance of the Work;
 - c. Become familiar with federal, state, and local laws, ordinances, rules, and regulations that may in any manner affect cost, progress or performance of the Work;
 - d. Study and carefully correlate Bidder's observations with the *Contract Documents*, and;

- e. Notify the Purchasing Agent of all conflicts, errors, ambiguities or discrepancies in or among the *Contract Documents* within the designated inquiry period.

On request, the Owner will provide each Offeror access to the site to conduct such investigations and tests as each Bidder deems necessary for submission of a Bid. It shall be the Offeror's responsibility to make or obtain any additional examinations, investigations, explorations, tests and studies and obtain any additional information and data which pertain to the physical conditions (including without limitation, surface, subsurface and underground utilities) at or contiguous to the site or otherwise which may affect cost, progress or performance of the work and which the Offeror deems necessary to determine its Bid for performing the work in accordance with the time, price and other terms and conditions of the *Contract Documents*. Location of any excavation or boring made by Offeror shall be subject to prior approval of Owner and applicable agencies. Offeror shall fill all holes, restore all pavements to match the existing structural section and shall clean up and restore the site to its former condition upon completion of such exploration. The Owner reserves the right to require the Offeror to execute an access agreement with the Owner prior to accessing the site.

The lands upon which the Work is to be performed, rights of way, and access thereto, and other lands designated for use by Contractor in performing the Work, are identified on the Drawings.

Information and data reflected in the *Contract Documents* with respect to underground utilities at or contiguous to the site are based upon information and data furnished to the Owner and the Engineer by the owners of such underground utilities or others, and the Owner does not assume responsibility for the accuracy or completeness thereof, unless it is expressly provided otherwise in the *Contract Documents*.

By submission of a Bid, the Offeror shall be conclusively presumed to represent that the Offeror has complied with every requirement of these Instructions to Bidders, that the *Contract Documents* are not ambiguous and are sufficient in scope and detail to indicate and convey understanding of all terms and conditions for performance of the Work.

- 1.16. Questions Regarding Statement of Work:** Any information relative to interpretation of Scope of Work or specifications shall be requested of the Purchasing Representative, in writing, in ample time, prior to the inquiry deadline.
- 1.17. Addenda & Interpretations:** If it becomes necessary to revise any part of this solicitation, a written addendum will be posted electronically on the City's website at <http://www.gjcity.org/business-and-economic-development/bids/> . The Owner is not bound by any oral representations, clarifications, or changes made in the written specifications by Owner, unless such clarification or change is provided in written addendum form from the City Purchasing Representative.
- 1.18. Taxes:** The Owner is exempt from State, County, and Municipal Sales Tax and Federal Excise Tax, therefore, all fees and costs should not include taxes.

- 1.19. Sales and Use Taxes:** The Contractor and all Subcontractors are required to obtain exemption certificates from the Colorado Department of Revenue for sales and use taxes in accordance with the provisions of the General Contract Conditions, Section XVI "Taxes". Bids shall reflect this method of accounting for sales and use taxes on materials, fixtures, and equipment.
- 1.20. Offers Binding 60 Days:** Unless additional time is required by the Owner, or otherwise specified, all formal offers submitted shall be binding for sixty (60) calendar days following opening date, unless the Bidder, upon request of the Purchasing Agent, agrees to an extension.
- 1.21. Exceptions and Substitutions:** All bids meeting the intent of this IFB shall be considered for award. A Bidder taking exception to the specifications does so at the Bidder's risk. The Owner reserves the right to accept or reject any or all substitutions or alternatives. When offering substitutions and/or alternatives, Bidder must state any exception(s) in the section to which the exception(s) pertain. Exception/substitution, if accepted, must meet, or exceed the stated intent and/or specifications. The absence of stated exception(s) indicates that the Bidder has not taken exception, and if awarded a Contract shall hold the Bidder responsible to perform in strict accordance with the specifications or scope of the bid and Contract Documents.
- 1.22. Collusion Clause:** Each Bidder by submitting a bid certifies that it is not party to any collusive action or any action that may be in violation of the Sherman Antitrust Act. Any and all bids shall be rejected if there is evidence or reason for believing that collusion exists among Bidders. The Owner may, or may not, accept future bids for the same Work or commodities from participants in such collusion.
- 1.23. Disqualification of Bidders:** A Bid will not be accepted from, nor shall a Contract be awarded to, any person, firm, corporation, or entity that is in arrears to the Owner, upon debt or contract, or that has defaulted, as surety or otherwise, upon any obligation to the Owner, or that is otherwise deemed irresponsible or unreliable.

Bidders may be required to submit satisfactory evidence that they are responsible, have a practical knowledge of the project bid upon and that they have the necessary financial and other resources to complete the proposed Work.

Either of the following reasons, without limitation, shall be considered sufficient to disqualify a Bidder and Bid:

- a. More than one Bid is submitted for the same Work from an individual, firm, or corporation under the same or different name; and
- b. Evidence of collusion among Bidders. Any participant in such collusion shall not receive recognition as a Bidder for any future work of the Owner until such participant has been reinstated as a qualified bidder.

- 1.24. Public Disclosure Record:** If the Bidder has knowledge of its employee(s) or sub-contractors having an immediate family relationship with an Owner employee or elected official, the Bidder must provide the Purchasing Agent with the name(s) of the individuals.

The individuals are required to file a “Public Disclosure Record”, a statement of financial interest, before conducting business with the Owner.

2. General Contract Conditions for Construction Projects

- 2.1. The Contract:** This Invitation for Bid submitted documents, Bidder’s Bid and any negotiations, when properly accepted by the Owner, shall constitute an enforceable Contract equally binding between the Owner and Contractor. The Contract represents the entire and integrated agreement between the Owner and Contractor and supersedes all prior negotiations, representations, or agreements, either written or oral including the bid documents. The Contract may be amended or modified with Change Orders, Field Orders, or Addendums.
- 2.2. The Work:** The term Work includes all labor necessary to produce the construction required by the Contract Documents, and all materials and equipment incorporated or to be incorporated in such construction.
- 2.3. Execution, Correlation, Intent, and Interpretations:** The Contract Documents shall be signed by the Owner and Contractor. By executing the Contract, the Contractor represents that it has familiarized itself with the local conditions under which the Work is to be performed and correlated its observations with the requirements of the Contract Documents. The Contract Documents are complementary, and what is required by anyone, shall be as binding as if required by all. The intention of the Contract Documents is to include all labor, materials, equipment, services, and other items necessary for the proper execution and completion of the Scope of Work as defined in the technical specifications and drawings contained herein. All drawings, specifications and copies furnished by the Owner are, and shall remain, Owner property. It is not to be used on any other project.
- 2.4. The Owner:** The Owner is the City and is referred to throughout the Contract Documents. The term Owner means the Owner or its authorized representative. The Owner shall, at all times, have access to the Work wherever it is in preparation and progress. The Contractor shall provide facilities for such access. The Owner will make periodic visits to the site to familiarize itself generally with the progress and quality of Work and to determine, in general, if the Work is proceeding in accordance with the Contract Documents. Based on such observations and the Contractor’s Application for Payment, the Owner will determine the amounts owing to the Contractor and will issue Certificates for Payment in such amounts as provided in the Contract. The Owner will have authority to reject Work which does not conform to the Contract Documents. Whenever, in its reasonable opinion, it considers it necessary or advisable to ensure the proper implementation of the intent of the Contract Documents, it will have authority to require the Contractor to stop the Work or any portion, or to require special inspection or testing of the Work, whether or not such Work can be then be fabricated, installed, or completed. The Owner will not be responsible for the acts or omissions of the Contractor, and Sub-Contractor, or any of its agents or employees, or any other persons performing any of the Work.

- 2.5. Contractor:** The Contractor is the person or organization identified as such in the Agreement and is referred to throughout the Contract Documents. The term Contractor means the Contractor or its authorized representative. The Contractor shall carefully study and compare the General Contract Conditions of the Contract, Specification and Drawings, Scope of Work, Addenda and Modifications and shall at once report to the Owner any error, inconsistency, or omission it may discover. Contractor shall not be liable to the Owner for any damage resulting from such errors, inconsistencies, or omissions. The Contractor shall not commence Work without clarifying Drawings, Specifications, or Interpretations.
- 2.6. Sub-Contractors:** A Sub-Contractor is a person or organization that has a direct Contract with the Contractor to perform any of the Work at the site. The term Sub-Contractor is referred to throughout the Contract Documents and means a Sub-Contractor or its authorized representative.
- 2.7. Award of Sub-Contractors & Other Contracts for Portions of the Work:** Contractor shall submit with its bid response to the Owner, in writing for acceptance, a list of the names of the sub-contractors or other persons or organizations proposed for such portions of the Work as may be designated in the bid requirements, or, if none is so designated, the names of the sub-contractors proposed for the principal portions of the Work. Prior to the award of the Contract, the Owner shall notify the successful Contractor in writing if, after due investigation, has reasonable objection to any person or organization on such list. If, prior to the award of the Contract, the Owner has a reasonable and substantial objection to any person or organization on such list and refuses in writing to accept such person or organization, the successful Contractor may, prior to the award, withdraw its bid without forfeiture of bid security. If the successful Contractor submits an acceptable substitute with an increase in the proposed price to cover the difference in cost occasioned by the substitution, the Owner may, at its discretion, accept the increased bid or may disqualify the Contractor. If, after the award, the Owner refuses to accept any person or organization on such list, the Contractor shall submit an acceptable substitute, and the Contract sum shall be increased or decreased by the difference in cost occasioned by such substitution and an appropriate Change Order shall be issued. No increase in the Contract sum shall be allowed for any such substitution unless the Contractor has acted promptly and responsively in submitting a name with respect thereto prior to the award.
- 2.8. Quantities of Work and Unit Price:** Materials or quantities stated as unit price items in the Bid are supplied only to give an indication of the general scope of the Work, and are, as such, estimates only. The Owner does not expressly or by implication agree that the actual amount of Work or material will correspond therewith and reserves the right after award to increase or decrease the quantity of any unit item of the Work without a change in the unit price except as set forth in Article VIII, Section 70 of the *General Contract Conditions*. The City also reserves the right to make changes in the Work (including the right to delete any bid item in its entirety or add additional bid items) as set forth in Article VIII, Sections 69 through 71 of the *General Contract Conditions*.
- 2.9. Substitutions:** The materials, products and equipment described in the *Solicitation Documents* shall be regarded as establishing a standard of required performance, function, dimension, appearance, or quality to be met by any proposed substitution. No

substitution will be considered prior to receipt of Bids unless the Bidder submits a written request for approval to the Purchasing Agent at least ten (10) days prior to the date for receipt of Bids. Such requests for approval shall include the name of the material or equipment for which substitution is sought and a complete description of the proposed substitution including drawings, performance and test data, and other information necessary for evaluation, including samples if requested. The Bidder shall set forth changes in other materials, equipment, or other portions of the Work including changes of the Work of other Contracts which incorporation of the proposed substitution would require to be included. The Owner's decision of approval or disapproval of a proposed substitution shall be final. If the Owner approves a proposed substitution before receipt of Bids, such approval will be set forth in an Addendum. Bidders shall not rely upon approvals made in any other manner.

- 2.10. Supervision and Construction Procedures:** The Contractor shall supervise and direct the Work, using its best skill and attention. It shall be solely responsible for all construction means, methods, techniques, sequences, and procedures and for coordinating all portions of the Work under the Contract.
- 2.11. Warranty:** The Contractor warrants to the Owner that all materials and equipment furnished under the Contract will be new unless otherwise specified, and that all Work will be of good quality, free from faults and defects and in conformance with the Contract Documents. All Work not conforming to these standards may be considered defective. If required by Owner, the Contractor shall furnish satisfactory evidence as to the kind and quality of materials and equipment. If within ten (10) days after written notice to the Contractor requesting such repairs or replacement, the Contractor should neglect to make or undertake with due diligence to the same, the City may make such repairs or replacements. All indirect and direct costs of such correction or removal or replacement shall be at the Contractor's expense. The Contractor will also bear the expenses of making good all Work of others destroyed or damaged by the correction, removal, or replacement of its defective Work.
- 2.12. Permits, Fees, & Notices:** The Contractor shall secure and pay for all permits, fees, and licenses necessary for the proper execution and completion of the Work. The Contractor shall give all notices and comply with all laws, ordinances, rules, regulations, and orders of any public authority, including the City, bearing on the performance of the Work. If the Contractor observes that any of the Contract Documents are at variance in any respect, it shall promptly notify the Purchasing Agent in writing, and any necessary changes shall be adjusted. If the Contractor performs any Work knowing it to be contrary to such laws, ordinances, rules, and regulations, and without such notice to the Owner, it shall assume full responsibility and shall bear all costs attributable to the non-conforming Work.
- 2.13. Responsibility for Those Performing the Work:** The Contractor shall be responsible to the Owner for the acts and omissions of all its employees and all sub-contractors, its agents and employees, and all other persons performing any of the Work under a Contract with the Contractor.

- 2.14. Use of the Site:** The Contractor shall confine operations at the site to areas permitted by law, ordinances, permits and the Contract Documents, and shall not unreasonably encumber the site with any materials or equipment.
- 2.15. Cleanup:** The Contractor at all times shall keep the premises free from accumulation of waste materials or rubbish caused by its operations. At the completion of Work, it shall remove all its waste materials and rubbish from and about the project, as well as all its tools, construction equipment, machinery, and surplus materials.
- 2.16. Insurance Requirements:** The selected Contractor agrees to procure and maintain, at its own cost, policies of insurance sufficient to insure against all liability, claims, demands, and other obligations assumed by the Contractor pursuant to the Contract. Such insurance shall be in addition to any other insurance requirements imposed by the Contract and/or by law. The Contractor shall not be relieved of any liability, claims, demands, or other obligations assumed pursuant to the Contract by reason of its failure to procure or maintain insurance in sufficient amounts, durations, or types.

Contractor shall procure and maintain and, if applicable, shall cause any Sub-contractor of the Contractor to procure and maintain insurance coverage listed below. Such coverage shall be procured and maintained with forms and insurers acceptable to Owner. All coverage shall be continuously maintained to cover all liability, claims, demands, and other obligations assumed by the Contractor pursuant to the Contract. In the case of any claims-made policy, the necessary retroactive dates and extended reporting periods shall be procured to maintain such continuous coverage. Minimum coverage limits shall be as indicated below unless specified otherwise in the Special Conditions:

(a) Worker Compensation: Contractor shall comply with all State of Colorado Regulations concerning Workers' Compensation insurance coverage.

(b) General Liability insurance with minimum limits of:

ONE MILLION DOLLARS (\$1,000,000) each occurrence and
ONE MILLION DOLLARS (\$1,000,000) per job aggregate.

The policy shall be applicable to all premises, products, and completed operations. The policy shall include coverage for bodily injury, broad form property damage (including completed operations), personal injury (including coverage for contractual and employee acts), blanket contractual, products, and completed operations. The policy shall include coverage for explosion, collapse, and underground (XCU) hazards. The policy shall contain a severability of interests' provision.

(c) Comprehensive Automobile Liability insurance with minimum limits for bodily injury and property damage of not less than:

ONE MILLION DOLLARS (\$1,000,000) each occurrence and
ONE MILLION DOLLARS (\$1,000,000) aggregate

(d) Professional Liability & Errors and Omissions Insurance policy with a minimum of:

ONE MILLION DOLLARS (\$1,000,000) per claim

This policy shall provide coverage to protect the City against liability incurred as a result of the professional Services performed as a result of responding to this Solicitation.

With respect to each of Contractors owned, hired, or non-owned vehicles assigned to be used in performance of the Work. The policy shall contain a severability of interest provision.

2.16.1 Additional Insured Endorsement: The policies required by paragraphs (b), and (c) above shall be endorsed to include the City, its Elected and Appointed Officials, Employees and Volunteers as Additional Insured. Every required policy above shall be primary insurance, and any insurance carried by the Owner, its officers, or its employees, or carried by or provided through any insurance pool of the Owner, shall be excess and not contributory insurance to that provided by the Contractor. The Contractor shall be solely responsible for any deductible losses under any policy required above.

2.17 Indemnification: The Contractor shall defend, indemnify and save harmless the Owner, and all its officers, employees, insurers, and self-insurance pool, from and against all liability, suits, actions, or other claims of any character, name and description brought for or on account of any injuries or damages received or sustained by any person, persons, or property on account of any negligent act or fault of the Contractor, or of any Contractor's agent, employee, Sub-Contractor or supplier in the execution of, or performance under, any Contract which may result from bid award. Contractor shall pay any judgment with cost which may be obtained by and/or against the Owner growing out of or under the performance.

2.18. Miscellaneous Conditions: Material Availability: The Contractor must accept responsibility for verification of material availability, production schedules, and other pertinent data prior to submission of bid. It is the responsibility of the Bidder to notify the Owner immediately if materials specified are discontinued, replaced, or not available for an extended period of time.

2.19. Time: Time is of the essence with respect to the Project and any other milestones or deadline which are part of the Contract. It will be necessary for each Bidder to satisfy the City of its ability to complete the Work within the Contract time set forth in the Contract Documents. The Contract time is the period of time allotted in the Contract Documents for completion of the Work. The date of commencement of the Work is the date established in a Notice to Proceed. If there is no Notice to Proceed, it shall be the date of the Contract, or such other date as may be established therein, or as established as entered on the Bid Form. The Date of Final Completion of the Work is the date certified by the Owner when all construction, and all other Work including, but not be limited to: testing, QA/QC, receipt of required reports and/or forms, grant requirements (if applicable), punch list items, clean-up, receipt of drawings and/or as-builts, etc., is fully complete, and in accordance with the Contract Documents.

2.20. Progress & Completion: The Contractor shall begin the Work on the Commencement Date as noted on the Notice to Proceed and perform the Work expeditiously with adequate forces to complete the Work within the Contract time/by the Completion date.

- 2.21. Payment & Completion:** The Contract Sum is stated in the Contract and is the total amount payable by the Owner to the Contractor for the performance of the Work under the Contract Documents. Upon receipt of written notice that the Work is ready for final inspection and acceptance and upon receipt of application for payment, the Owner's Project Manager will promptly make such inspection and, when it finds the Work acceptable under the Contract Documents and the Contract fully performed, the Owner shall make payment in the manner provided in the Contract Documents.
- 2.22. Bid Bond:** Each bid shall as a guaranty of good faith on the part of the Offeror be accompanied by a Bid Guaranty consisting of a certified or cashier's check drawn on an approved national bank or trust company in the State of Colorado and made payable without condition to the City; or a **Bid Bond** written by an approved corporate surety in favor of the City. The amount of the Bid Guaranty shall not be less than 5% of the total Bid amount. Once a Bid is accepted and a Contract is awarded, the apparent successful Offeror has ten calendar days to enter into a Contract in the form prescribed and to furnish the bonds with a legally responsible and approved surety. Failure to do so will result in forfeiture of the Bid Guaranty to the City as Liquidated Damages.

Each Offeror shall guarantee its total bid price for a period of sixty (60) Calendar Days from the date of the bid opening.

- 2.23. Performance & Payment Bonds:** The Contractor shall furnish a Performance and a Payment Bond, each in an amount at least equal to that specified for the Contract amount as security for the faithful performance and payment of all Contractor's obligations under the Contract Documents. These bonds shall remain in effect for the duration of the Warranty Period (as specified in the Special Conditions). The Contractor shall also furnish any other bonds that may be required by the Special Conditions. All bonds shall be in the forms prescribed by the Contract Documents and be executed by such sureties as (1) are licensed to conduct business in the State of Colorado and (2) are named in the current list of "Companies Holding Certificates of Authority as Acceptable Sureties on Federal Bonds and as Acceptable Reinsuring Companies" as published in Circular 570 (amended) by the Audit Staff, Bureau of Accounts, U.S. Treasury Department. All bonds signed by an agent must be accompanied by a certified copy of the Authority Act. If the surety on any bond furnished by the Contractor is declared bankrupt or becomes insolvent, or its rights to do business in Colorado are terminated, or it ceases to meet the requirements of clauses (1) and (2) of this section, the Contractor shall within five (5) days thereafter substitute another bond and surety, both of which shall be acceptable to the City.
- 2.24. Retention:** The Owner will deduct money from the partial payments in amounts considered necessary to protect the interest of the Owner and will retain this money until after completion of the entire Contract. The amount to be retained from partial payments will be five (5) percent of the value of the completed Work, and not greater than five (5) percent of the amount of the Contract. When the retainage has reached five (5) percent of the amount of the Contract no further retainage will be made and this amount will be retained until such time as final payment is made.
- 2.25. Liquidated Damages for Failure to Enter Into Contract:** Should the Successful Bidder fail or refuse to enter into the Contract within ten Calendar Days from the issuance of the

Notice of Award, the City shall be entitled to collect the amount of such Bidder's Bid Guaranty as Liquidated Damages, not as a penalty but in consideration of the mutual release by the City and the Successful Bidder of all claims arising from the City's issuance of the Notice of Award and the Successful Bidder's failure to enter into the Contract and the costs to award the Contract to any other Bidder, to readvertise, or otherwise dispose of the Work as the City may determine best serves its interest.

2.26. Delay Damages for Failure to Meet Project Completion Schedule: If the Contractor does not achieve Final Completion by the required date, whether by neglect, refusal or any other reason, the parties agree and stipulate that the Contractor shall pay liquidated damages to the City for each such day that final completion is late. As provided elsewhere, this provision does not apply for delays caused by the City. The date for Final Completion may be extended in writing by the Owner.

The Contractor agrees that as a part of the consideration for the City's awarding of this Contract liquidated damages in the daily amount of **\$500.00** is reasonable and necessary to pay for the actual damages resulting from such delay. The parties agree that the real costs and injury to the City for such delay include hard to quantify items such as: additional engineering, inspection and oversight by the City and its agents; additional contract administration; inability to apply the efforts of those employees to the other work of the City; perceived inefficiency of the City; citizens having to deal with the construction and the Work, rather than having the benefit of a completed Work, on time; inconvenience to the public; loss of reputation and community standing for the City during times when such things are very important and very difficult to maintain.

The Contractor must complete the Work and achieve final completion included under the Bid Schedule in the number of consecutive calendar days after the City gives its written Notice to Proceed. When the Contractor considers the entire Work ready for its intended use, Contractor shall certify in writing that the Work is fully complete. Final Completion date is the date by which the Contractor shall have fully completed all clean-up, and all items that were identified by the City in the inspection for final completion. Unless otherwise stated in the Special Conditions, for purposes of this liquidated damages clause, the Work shall not be finished, and the Contract time shall continue to accrue until the City gives its written Final Acceptance.

If the Contractor shall fail to pay said liquidated damages promptly upon demand thereof after having failed to achieve Final Completion on time, the City shall first look to any retainage or other funds from which to pay said liquidated damages; if retainage or other liquid funds are not available to pay said liquidated damages amounts, the Surety on the Contractor's Performance Bond and Payment Bond shall pay such liquidated damages. In addition, the City may withhold all, or any part of, such liquidated damages from any payment otherwise due the Contractor.

Liquidated damages as provided do not include any sums to reimburse the City for extra costs which the City may become obligated to pay on other contracts which were delayed or extended because of the Contractor's failure to complete the Work within the Contract Time. Should the City incur additional costs because of delays or extensions to other contracts resulting from the Contractor's failure of timely performance, the Contractor

agrees to pay these costs that the City incurs because of the Contractor's delay, and these payments are separate from and in addition to any liquidated damages.

The Contractor agrees that the City may use its own forces or hire other parties to obtain Final Completion of the work if the time of completion has elapsed and the Contractor is not diligently pursuing completion. In addition to the Liquidated Damages provided for, the Contractor agrees to reimburse the City for all expenses thus incurred.

- 2.27. Contingency/Force Account/Minor Contract Revisions:** Contingency/Force Account/Minor Contract Revisions Work will be authorized by the Owner's Project Manager and is defined as minor expenses to cover miscellaneous or unforeseen expenses related to the project. The expenses are not included in the Drawings, Specifications, or Scope of Work and are necessary to accomplish the scope of this Contract. Contingency/Force Account/Minor Contract Revisions Authorization will be directed by the Owner through an approved form. Contingency/Force Account/Minor Contract Revisions funds are the property of the Owner and any Contingency/Force Account/Minor Contract Revisions funds, not required for project completion, shall remain the property of the Owner. Contractor is not entitled to any Contingency/Force Account/Minor Contract Revisions funds, that are not authorized by Owner or Owner's Project Manager.
- 2.28. Protection of Persons & Property:** The Contractor shall comply with all applicable laws, ordinances, rules, regulations, and orders of any public authority having jurisdiction for the safety of persons or property or to protect it from damage, injury, or loss. Contractor shall erect and maintain, as required by existing safeguards for safety and protection, and all reasonable precautions, including posting danger signs or other warnings against hazards promulgating safety regulations and notifying owners and users of adjacent utilities. When or where any direct or indirect damage or injury is done to public or private property by or on account of any act, omission, neglect, or misconduct by the Contractor in the execution of the Work, or in consequence of the non-execution thereof by the Contractor, it shall restore, at its own expense, such property to a condition similar or equal to that existing before such damage or injury was done, by repairing, rebuilding, or otherwise restoring as may be directed, or it shall make good such damage or injury in an acceptable manner.
- 2.29. Changes in the Work:** The Owner, without invalidating the Contract, may order changes in the Work within the general scope of the Contract consisting of additions, deletions or other revisions, the Contract sum and the Contract time being adjusted accordingly. All such changes in the Work shall be authorized by Change Order and shall be executed under the applicable conditions of the contract documents. A Change Order is a written order to the Contractor signed by the Owner issued after the execution of the Contract, authorizing a change in the Work or an adjustment in the contract sum or the Contract time. The Contract sum and the Contract time may be changed only by Change Order.
- 2.30. Claims for Additional Cost or Time:** If the Contractor wishes to make a claim for an increase in the Contract sum or an extension in the Contract time, it shall give the Owner written notice thereof within a reasonable time after the occurrence of the event giving rise to such claim. This notice shall be given by the Contractor before proceeding to

execute the Work, except in an emergency endangering life or property in which case the Contractor shall proceed in accordance with the regulations on safety. No such claim shall be valid unless so made. Any change in the Contract sum or Contract time resulting from such claim shall be authorized by Change Order.

- 2.31. Minor Changes in the Work:** The Owner shall have authority to order minor changes in the Work not involving an adjustment in the Contract sum or an extension of the Contract time and not inconsistent with the intent of the Contract Documents.
- 2.32. Field Orders:** The Owner may issue written Field Orders which interpret the Contract Documents in accordance with the specifications, or which order minor changes in the work in accordance with the agreement, without change in the contract sum or time. The Contractor shall carry out such Field Orders promptly.
- 2.33. Uncovering & Correction of Work:** The Contractor shall promptly correct all work rejected by the Owner as defective or as failing to conform to the contract documents whether observed before or after substantial completion and whether or not fabricated installed or completed. The Contractor shall bear all costs of correcting such rejected work, including the cost of the Owner's additional services thereby made necessary. If within one (1) year after the date of completion or within such longer period of time as may be prescribed by law or by the terms of any applicable special guarantee required by the contract documents, any of the work found to be defective or not in accordance with the contract documents, the Contractor shall correct it promptly after receipt of a written notice from the Owner to do so unless the Owner has previously given the Contractor a written acceptance of such condition. The Owner shall give such notice promptly after discovering of the condition. All such defective or non-conforming work under the above paragraphs shall be removed from the site where necessary and the work shall be corrected to comply with the contract documents without cost to the Owner. The Contractor shall bear the cost of making good all work of separate Contractors destroyed or damaged by such removal or correction. If the Owner prefers to accept defective or non-conforming work, he may do so instead of requiring its removal and correction, in which case a Change Order will be issued to reflect an appropriate reduction in the payment or Contract sum, or, if the amount is determined after final payment, it shall be paid by the Contractor.
- 2.34. Amendment:** No oral statement of any person shall modify or otherwise change, or affect the terms, conditions or specifications stated in the resulting contract. All amendments to the Contract shall be made in writing by the Owner.
- 2.35. Assignment:** The Contractor shall not sell, assign, transfer or convey any Contract resulting from this IFB, in whole or in part, without the prior written approval from the Owner.
- 2.36. Compliance with Laws:** Bids must comply with all Federal, State, County, and local laws governing its Work and the fulfillment of the Work for and on behalf of the public. Contractor hereby warrants that it is qualified to assume the responsibilities and render the Work described herein and has all requisite corporate authority and professional licenses in good standing as required by law.

- 2.37. Confidentiality:** All information disclosed by the Owner to the Contractor for the purpose of the work to be done, or information that comes to the attention of the Contractor during the course of performing such Work is to be kept strictly confidential.
- 2.38. Conflict of Interest:** No public official and/or City/County employee shall have interest in any Contract resulting from this Invitation for Bid.
- 2.39. Contract Termination:** This Contract shall remain in effect until any of the following occurs: (1) Contract expires; (2) completion of Work; (3) final acceptance of Work or, (4) for convenience terminated by either party with a written *Notice of Cancellation* stating therein the reasons for such cancellation and the effective date of cancellation at least thirty (30) days past notification.
- 2.40. Employment Discrimination:** During the performance of any Work, the Contractor, by submitting a Bid, agrees to the following conditions:
- 2.40.1.** The Contractor shall not discriminate against any employee or applicant for employment because of race, religion, color, sex, age, handicap, or national origin except when such condition is a legitimate occupational qualification reasonably necessary for the normal operations of the Contractor. The Contractor agrees to post in conspicuous places, visible to employees and applicants for employment, notices setting forth the provisions of this nondiscrimination clause.
- 2.40.2.** The Contractor, in all solicitations or advertisements for employees placed by or on behalf of the Contractor, shall state that such Contractor is an Equal Opportunity Employer.
- 2.40.3.** Notices, advertisements, and solicitations placed in accordance with federal law, rule, or regulation shall be deemed sufficient for the purpose of meeting the requirements of this section.
- 2.41. Affirmative Action:** In executing a Contract with the City, the Contractor agrees to comply with Affirmative Action and Equal Employment Opportunity regulations presented in the General Contract Conditions Section 9 "Affirmative Action/EEO.
- 2.42. Immigration Reform and Control Act of 1986 and Immigration Compliance:** The Contractor certifies that it does not and will not during the performance of the Contract employ workers without authorization or otherwise violate the provisions of the Federal Immigration Reform and Control Act of 1986 and/or laws regulating immigration compliance.
- 2.43. Ethics:** No Bidder shall accept or offer gifts or anything of value nor enter into any business arrangement with any employee, official, or agent of the Owner.
- 2.44. Gratuities:** The Bidder shall certify and agree that no gratuities or kickbacks were or will be paid in connection with this Bid and/or an award of a Contract, nor were any fees, commissions, gifts, or other considerations made contingent upon the award of a

Contract. If the Service Provider breaches or violates this warranty, the Owner may at its discretion, terminate the Contract without liability to the Owner.

- 2.45. Failure to Deliver:** In the event of failure of the Contractor to perform in accordance with the Contract Documents, the Owner, after due oral or written notice, may procure the Work from other sources and hold the Contractor responsible for any costs resulting in additional Work, materials and/or administration services necessary to perform the Work. This remedy shall be in addition to any other remedies that the Owner may have.
- 2.46. Failure to Enforce:** Failure by the Owner at any time to enforce the provisions of the Contract shall not be construed as a waiver of any such provisions. Such failure to enforce shall not affect the validity of the Contract or any part thereof or the right of the Owner to enforce any provision of the Contract Documents at any time in accordance with the terms thereof.
- 2.47. Force Majeure:** The Contractor shall not be held responsible for failure to perform the duties and responsibilities imposed by the Contract due to legal strikes, fires, riots, rebellions, and acts of God beyond the control of the Contractor, unless otherwise specified in the Contract.
- 2.48. Independent Contractor:** The Contractor shall be legally considered an Independent Contractor and neither the Contractor nor its employees shall, under any circumstances, be considered servants or agents of the Owner. The Owner shall be at no time legally responsible for any negligence or other wrongdoing by the Contractor, its servants, or agents. The Owner shall not withhold from the Contractor payments to the Contractor any federal or state unemployment taxes, federal or state income taxes, Social Security, or any other amounts for benefits to the Contractor. Further, the Owner shall not provide to the Contractor any insurance coverage or other benefits, including Workers' Compensation, normally provided by the Owner for its employees.
- 2.49. Nonconforming Terms and Conditions:** A bid that includes terms and conditions that do not conform to the terms and conditions of this Invitation for Bid is subject to rejection as non-responsive. The Owner reserves the right to permit the Contractor to withdraw nonconforming terms and conditions from its bid prior to a determination by the Owner of non-responsiveness based on the submission of nonconforming terms and conditions.

Items for non-responsiveness may include, but not be limited to:

- a. Submission of the Bid on forms other than those supplied by the City;
- b. Alteration, interlineation, erasure, or partial detachment of any part of the forms which are supplied herein;
- c. Inclusion of unauthorized additions conditional or alternate Bids or irregularities of any kind which may tend to make the Bid incomplete, indefinite, or ambiguous as to its meaning;
- d. Failure to acknowledge receipt of any or all issued Addenda;
- e. Failure to provide a unit price or a lump sum price, as appropriate, for each pay item listed except in the case of authorized alternative pay items;
- f. Failure to list the names of Subcontractors used in the Bid preparation as may be required in the Solicitation Documents;

- g. Submission of a Bid that, in the opinion of the Owner, is unbalanced so that each item does not reasonably carry its own proportion of cost or which contains inadequate or unreasonable prices for any item;
- h. Tying of the Bid with any other bid or contract; and
- i. Failure to calculate Bid prices as described herein.

2.50. Evaluation of Bids and Offerors: The Owner reserves the right to:

- Reject any and all Bids,
- Waive any and all informalities,
- Take into account any prompt payment discounts offered by Bidder,
- Negotiate final terms with the Successful Bidder,
- Take into consideration past performance of previous awards/contracts with the Owner of any Contractor, Vendor, Firm, Supplier, or Service Provider in determining final award. and
- Disregard any and all nonconforming, nonresponsive or conditional Bids.

Discrepancies between words and figures will be resolved in favor of words. Discrepancies between Unit Prices and Extended Prices will be resolved in favor of the Unit Prices. Discrepancies between the indicated sum of any column of figures and the correct sum thereof will be resolved in favor of the correct sum. The corrected extensions and totals will be shown in the tabulation of Bids.

The Owner may consider the qualifications and experience of Subcontractors and other persons and organizations (including those who are to furnish the principal items of material or equipment) proposed for those portions of the work as to which the identity of Subcontractors and other persons and organizations must be submitted. Operating costs, maintenance considerations, performance data, and guarantees of materials and equipment may also be considered by the Owner.

The Owner will conduct such investigations as deemed necessary to assist in the evaluation of any Bid and to establish the responsibility, qualifications, and financial ability of the Bidder, proposed Subcontractors and other persons and organizations to do the Work in accordance with the *Contract Documents* to the City's satisfaction within the Contract Time.

The Bidder shall furnish the Owner all information and data requested by the Owner to determine the ability of the Bidder to perform the Work. The Owner reserves the right to reject the Bid if the evidence submitted by, or investigation of such Bidder fails to satisfy the Owner that such Bidder is properly qualified to carry out the obligations of the Contract and to complete the Work contemplated therein.

By submitting a Bid, each Bidder authorizes the Owner to perform such investigation of the Bidder as the Owner deems necessary to establish the responsibility, qualifications, and financial ability of the Bidder and, by its signature thereon, authorizes the Owner to obtain reference information concerning the Bidder and releases the party providing such information and the Owner from any and all liability to the Bidder as a result of such reference information so provided.

The Owner reserves the right to reject the Bid of any Offeror who does not pass any evaluation to the Owner's satisfaction.

If the Contract is to be awarded, it will be awarded to the Offeror who, by evaluation, the Owner determines will best meet the Owner's interests.

The Owner reserves the right to accept or reject the Work contained in any of the Price Bid Schedules or alternates, either in whole or in part.

2.51. Award of Contract: Unless otherwise indicated, a single award will be made for all the bid items in an individual bid schedule. In the event that the Work is contained in more than one Bid Schedule, the City may award Schedules individually or in combination. In the case of two Bid Schedules which are alternative to each other, only one of such alternative Schedules will be awarded. Within forty-five (45) Calendar Days of Bid Opening, the City will issue a Notice of Award to the Successful Bidder which will be accompanied by a Contract electronically submitted via DocuSign for digital signature. Within ten (10) Calendar Days thereafter, the Successful Bidder shall sign and deliver the digitally executed Contract via DocuSign. Performance Bond, Payment Bond, and Certificate of Insurance shall be submitted to the City within ten (10) days of Contract execution. No Contract shall exist between the Successful Bidder and the City and the Successful Bidder shall have no rights at law or in equity until the Contract has been duly executed by the City.

The Successful Bidder's failure to sign and submit a Contract and other documents set forth in this Paragraph within the prescribed time shall be just cause of annulment of the award, and forfeiture of the Bid Guaranty. The award of Contract may then be made to the next qualified Bidder in the same manner as previously prescribed.

2.52. Ownership: All plans, prints, designs, concepts, etc., shall become the property of the Owner.

2.53. Oral Statements: No oral statement of any person shall modify or otherwise affect the terms, conditions, or specifications stated in this document and/or resulting agreement. All modifications to this request and any agreement must be made in writing by the Owner.

2.54. Patents/Copyrights The Contractor agrees to protect the Owner from any claims involving infringements of patent(s) and/or copyright(s). In no event shall the Owner be liable to the Contractor for any claims, damages, awards and/or costs of defense arising on the grounds of patent(s)/copyright(s) infringement. Patent/copyright infringement shall null and void any agreement resulting from response to this Invitation For Bid.

2.55. Remedies: The Contractor and Owner agree that both parties have all rights, duties, and remedies available as stated in the Uniform Commercial Code.

2.56. Governing Law: The Contract and/or any agreement as a result of responding to this Invitation For Bid shall be deemed to have been made in, and shall be construed and interpreted in accordance with, the laws of the City of Grand Junction, Mesa County, Colorado.

- 2.57. Expenses:** Expenses incurred in preparation, submission, and presentation of a response to this Invitation For Bid are the responsibility of the Bidder and cannot be charged to the Owner.
- 2.58. Sovereign Immunity:** The Owner specifically reserves its right to sovereign immunity pursuant to Colorado law as a defense to any action arising out of this Contract.
- 2.59. Non-Appropriation of Funds:** Funds for payment have been provided through the Owner's budget approved by the City Council/Board of County Commissioners for the stated fiscal year only. State of Colorado prohibits the obligation and expenditure of public funds beyond the fiscal year for which a budget has been approved. Therefore, anticipated orders or other obligations that may arise past the end of the stated Owner's fiscal year shall be subject to budget approval. The Contract, if any, will be subject to and must contain a non-appropriation of funds clause/limitation on multi-year fiscal obligations as required by Art X, Section 20 of the Colorado Constitution, and other applicable law(s).
- 2.60. Cooperative Purchasing:** Purchases as a result of this Solicitation are primarily for the City/County. Other governmental entities may be extended the opportunity to utilize the resultant Contract award with the agreement of the successful provider and the participating agencies. All participating entities will be required to abide by the specifications, terms, conditions, and pricing established in this Bid. The quantities furnished in this bid document are for only the City/County. It does not include quantities for any other jurisdiction. The City or County will be responsible only for the award for its jurisdiction. Other participating entities will place its own awards on its respective Purchase Orders through its purchasing office or use its purchasing card for purchase/payment as authorized or agreed upon between the provider and the individual entity. The Owner accepts no liability for payment of orders placed by other participating jurisdictions that choose to "piggy-back" on Owner's Solicitation. Orders placed by participating jurisdictions under the terms of this Solicitation will indicate its specific delivery and invoicing instructions.
- 2.61. Keep Jobs in Colorado Act:** Contractor shall be responsible for ensuring compliance with Article 17 of Title 8, Colorado Revised Statutes (C.R.S.) requiring 80% Colorado labor to be employed on public works. Contractor shall, upon reasonable notice provided by the Owner, permit the Owner to inspect documentation of identification and residency required by C.R.S. §8-17-101(2)(a). If Contractor claims it is entitled to a waiver pursuant to C.R.S. §8-17-101(1), Contractor shall state that there is insufficient Colorado labor to perform the Work such that compliance with Article 17 would create an undue burden that would substantially prevent a project from proceeding to completion and shall include evidence demonstrating the insufficiency and undue burden in its response.

Unless expressly granted a waiver by the Owner pursuant to C.R.S. §8-17-101(1), Contractor shall be responsible for ensuring compliance with Article 17 of Title 8, C.R.S. requiring 80% Colorado labor to be employed on public works. Contractor shall, upon reasonable notice provided by the Owner, permit the Owner to inspect documentation of identification and residency required by C.R.S. §8-17-101(2)(a).

2.61.1. "Public project" is defined as:

- (a) any construction, alteration, repair, demolition, or improvement of any land, building, structure, facility, road, highway, bridge, or other public improvement suitable for and intended for use in the promotion of the public health, welfare, or safety and any maintenance programs for the upkeep of such projects
- (b) for which appropriate or expenditure of moneys may be reasonably expected to be \$500,000.00 or more in the aggregate for any fiscal year
- (c) except any project that receives federal moneys.

3. Statement of Work

3.1. GENERAL: The City of Grand Junction is soliciting competitive bids from qualified and interested Contractors for all labor, equipment, and materials required for the 2024 Parks Pedestrian Lighting Improvements Project. Products indicated in Attachment B: Materials Specifications are required materials; substitutions will likely not be allowed and must be approved by the Owner. Generally, boring and trenching activities will leave existing pathways intact and avoid damage to irrigation drip lines and control lines. Alteration of planned routes and structure placements may be allowed with approval from the Owner. All dimensions and scope of work should be verified by Contractors prior to submission of bids.

NOTE: The descriptions of the pay items listed in the Price Bid Schedule for this Project may not agree with those listed in the Standard Specifications. Payment for all Work performed, as required in the Contract Documents, will be in accordance with the items and units listed in the Price Bid Schedule.

The performance of the Work for this Project shall conform to the General Contract Conditions presented in the City of Grand Junction's Standard Contract Documents for Capital Improvements Construction, revised July 2010, except as specifically modified or supplemented herein or on the Construction Drawings.

3.2. PROJECT DESCRIPTION: The goal of this project is to improve lighting at City parks as part of the Crime Prevention Through Safer Streets Grant Program. The work locations are Columbine Park and Hawthorne Park, and generally consists of the removal of existing lighting equipment, the installation of 5,042 LF of 2-inch electrical conduit, 57 type two pull boxes, 52 light fixtures and foundations, 1 lighting controller, and associated wiring for installation. Additionally, as an add alternate, work at Sherwood Park includes removal of existing lighting and electrical equipment, installing 6 lighting fixtures and 4 power receptacles at two shelter buildings.

Bidding Includes an add alternate. Bidders may submit bids for the following:

Option 1: Lighting improvements at Columbine Park and Hawthorne Park only.

Option 2: Lighting improvements at Columbine Park, Hawthorne Park and Sherwood Park.

Sod and Reseeding:

The Contractor is responsible for the restoration of disturbed turf as follows:

- For trenches equal to or narrower than 8", the soil is settled, and grass reseeded.
- For trenches wider than 8", the soil is settled, and sod placed.
- For any ruts or turf damage caused by equipment, reseed or sod as necessary.

The Parks Department needs to be notified of any reseeding or sodding activities so that adjustments can be made to the irrigation schedule to help ensure success of the reestablishment of the turf.

3.3. SPECIAL CONDITIONS & PROVISIONS:

3.3.1 Non-Mandatory Pre-Bid Meeting: Prospective bidders are encouraged to attend non-mandatory pre-bid meeting on October 10, 2024, at 10:00AM. Meeting location is at City Hall Auditorium located at 250 N 5th Street, Grand Junction CO 81501. The purpose of this visit will be to inspect and to clarify the contents of this Invitation for Bids (IFB).

3.3.2 Prequalification Requirement: Contractors submitting bids over \$500,000 must be pre-qualified in accordance with the City's "*Contractors Prequalification Application*". All bids received by the specified time will be opened, but the City will reject bids over \$500,000 from contractors who have not been prequalified. Application forms for prequalification are available by clicking the [Application Link](#) Call 970-256-4082 for additional information. Due to the time required to process applications, *all applications must be submitted no later than the application due date stated in the Solicitation document.* Contractors may view its approved pre-qualified categories by clicking the [Pre-Qualification List Link](#).

Pre-Qualification: Contractors must either be pre-qualified in category *1B Park Improvements* or submit the above noted Pre-Qualification Application. This requirement is to comply with State safety rules and regulations.

3.3.3 QUESTIONS REGARDING SOLICITATION PROCESS/SCOPE OF WORK:

Dolly Daniels; Senior Buyer/Purchasing Agent
City of Grand Junction
dollyd@gjcity.org

3.3.4 Project Manager: The Project Manager for the Project is Evan Sales, Engineering Specialist, who can be reached at (970) 244-1558 or evan.sales@gjcity.org. During Construction, all notices, letters, submittals, and other communications directed to the City shall be addressed and mailed or delivered to:

City of Grand Junction
Department of Public Works and Planning
Attn: Evan Sales, Project Manager
244 North 7th Street
Grand Junction, CO 81501

3.3.5 Contract Administrator: The Contract Administrator for the Project is Duane Hoff Jr., Contract Administrator, who can be reached at (970)244-1545. During Construction, Contract related inquiries, issues, and other communications shall be directed to:

Duane Hoff Jr., Contract Administrator
duaneh@gjcity.org

3.3.6 Affirmative Action: The Contractor is not required to submit a written Affirmative Action Program for the Project.

3.3.7 Pricing: Pricing shall be all inclusive to include but not be limited to: all labor, equipment, supplies, materials, freight (F.O.B. Destination – Freight Pre-paid and Allowed to each site), travel, mobilization costs, fuel, set-up and take down costs, and full-time inspection costs, and all other costs related to the successful completion of the Project.

The Owner shall not pay nor be liable for any other additional costs including but not limited to: taxes, shipping charges, insurance, interest, penalties, termination payments, attorney fees, liquidated damages, etc.

3.3.8 Freight/Shipping: All freight/shipping shall be F.O.B. Destination – Freight Pre-Paid and Allowed to the project site(s), Grand Junction, CO.

Contractor must meet all federal, state, and local rules, regulations, and requirements for providing such services.

3.3.9 Contract: A binding contract shall consist of: (1) the IFB and any amendments thereto, (2) Additional Documents as stated in Section 1.10, (3) the bidder's response (bid) to the IFB, (4) clarification of the bid, if any, and (5) the City's Purchasing Department's acceptance of the bid by "Notice of Award" or by "Purchase Order". All Exhibits and Attachments included In the IFB shall be incorporated into the Contract by reference.

A. The Contract expresses the complete agreement of the parties and, performance shall be governed solely by the specifications and requirements contained therein.

B. Any change to the Contract, whether by modification and/or supplementation, must be accomplished by a formal contract amendment signed and approved by and between the duly authorized representative of the bidder and the City Purchasing Division or by a modified Purchase Order prior to the effective date of such modification. The bidder expressly and explicitly understands and agrees that no other method and/or no other document, including acts and oral communications by or from any person, shall be used or construed as an amendment or modification to the contract.

3.3.10 Time of Completion: The scheduled time of Completion for the Project is 109 Calendar Days from the starting date specified in the Notice to Proceed.

Completion is achieved when site cleanup and all punch list items (resulting from the final inspection) have been completed. Completion shall have the meaning set forth in Article I, Section 3 (Definitions and Terms) of the General Contract Conditions.

3.3.11 Working Days and Hours: The working days and hours shall be as stated in the General Contract Conditions or as mutually agreed upon in the preconstruction meeting with the following exception:

All work shall be performed between the hours of 7:00 AM to 5:00 PM.

3.3.12 Licenses and Permits: Contractor is responsible for obtaining all necessary licenses and permits required for Construction, at Contractors expense. See Section 2.12. Contractor shall supply to Owner all copies of finalized permits.

3.3.13 Permits: The following permits are required for the Project and will be obtained by the City at no cost to the Contractor:

- None

The Contractor shall strictly adhere to the stipulations imposed by these permits.

The following permits are required for the Project and shall be obtained and paid for by the Contractor, with the costs included in the total bid price for the Project:

Building/Electrical Permits (as necessary)

3.3.14 City Furnished Materials: The City will furnish the following materials for the Project:

- None

3.3.15 Authorized Representatives of the City: Those authorized to represent the City shall include Purchasing Agent, Engineers, and Inspectors employed by the City, only.

3.3.16 Stockpiling Materials and Equipment: All stockpiling/storage shall be in accordance with General Contract Condition Section 51.

3.3.17 Traffic Control: Traffic control, if required, is the responsibility of the Contractor.

3.3.18 Clean-Up: The Contractor is responsible for cleaning up all loose materials that have been deposited or swept into gutters, and onto sidewalks and driveways as a result of sidewalk operations. The costs for all clean-up work shall be considered incidental and will not be paid for separately.

3.3.19 Quality Control Testing: The Contractor is required to retain a consultant to perform quality control materials testing to determine the conformance of the work with the specifications.

3.3.20 Schedule of Submittals: Contractor shall deliver these submittals at least two days prior to the pre-construction meeting:

- Project Schedule

3.3.21 Excess Material: All excess materials shall be disposed in accordance with General Contract Condition Section 50.

3.3.22 Existing Utilities and Structures: Utilities were **not** potholed during design of this Project. The location of existing utilities and structures shown on the Plans is approximate with the information gathered during design. It is the responsibility of the Contractor to pothole/locate and protect all structures and utilities in accordance with General Contract Condition Section 37.

3.3.23 Incidental Items: Any item of work not specifically identified or paid for directly, but which is necessary for the satisfactory completion of any paid items of work, will be considered as incidental to those items, and will be included in the cost of those items.

3.3.24 Survey: The Contractor shall give the City survey crew a minimum of 72 hours' notice for all requested surveys.

3.3.25 Work to be Performed by the City (Prior to Construction):

- None

3.3.26 Existing Concrete Sidewalks, Pans, Fillets, Curbs and Gutters: The existing sidewalks, pans, fillets, curb and gutter are in good serviceable condition. In most instances the installation of new sidewalks and pavement will be adjacent to existing concrete. The Contractor will need to protect all concrete adjacent to construction. If the concrete is damaged during construction the Contractor will be responsible for its replacement at no cost to the City. The Contractor, the City Project Inspector, and/or the City Project Manager will walk and record any concrete that is deemed to be damaged before construction has started.

3.3.27 Weekly Progress Meetings: The Contractor and Engineer shall schedule and hold Weekly progress meetings. The purpose of the meetings will be to review the progress of the work, maintain coordination efforts, discuss the schedule, and resolve issues that may develop.

3.4. Attachments:

- [Construction Drawings](#)
- [Materials Specifications](#)

3.5. Contractor Bid Documents: For Contractor's convenience, the following is a list of forms/items to be submitted with the Contractor's bid response. However, should a form/item not be listed in this section, but required in the solicitation documents, it is the Contractor's responsibility to ensure all forms/items are submitted.

- Signed Contractors Bid Form
- Price Bid Schedule

3.6. IFB TENTATIVE TIME SCHEDULE:

| | |
|--|--|
| Invitation For Bids available | September 30, 2024 |
| Non-Mandatory Pre-Bid Meeting | October 10, 2024, 10:00AM |
| Pre-Qualification Deadline | October 21, 2024 |
| Inquiry deadline, no questions after this date | October 21, 2024, 5:00PM |
| Addendum Posted | October 23, 2024 |
| Submittal deadline for proposals | October 30, 2024, 2:00PM |
| City Council Approval | November 20, 2024 |
| Notice of Award & Contract execution | November 21, 2024 |
| Bonding & Insurance Cert due | December 2, 2024 |
| Preconstruction meeting | TBD |
| Work begins no later than | Receipt of Notice to Proceed |
| Final Completion | 109 Calendar Days from Notice to Proceed. |

Holidays:

| | |
|----------------------------|----------------------|
| Veteran's Day | November 11, 2024 |
| Thanksgiving Day | November 28-29, 2024 |
| Christmas Day | December 25, 2024 |
| New Year's Day | January 1, 2025 |
| Martin Luther King Jr. Day | January 20, 2025 |
| Presidents Day | February 17, 2025 |

4. Contractor's Bid Form

Project: IFB-5521-24-DD "Parks Pedestrian Lighting Improvements"

Bid Date: _____

Bidding Company: _____

Name of Authorized Agent: _____

Email _____

Telephone _____ **Address** _____

City _____ **State** _____ **Zip** _____

The undersigned Bidder, in compliance with the Invitation for Bids, having examined the Instruction to Bidders, General Contract Conditions, Statement of Work, Specifications, and any and all Addenda thereto, having investigated the location of, and conditions affecting the proposed work, hereby proposes to furnish all labor, materials and supplies, and to perform all work for the Project in accordance with Contract Documents, within the time set forth and at the prices stated below. These prices are to cover all expenses incurred in performing the work required under the Contract Documents, of which this Contractor's Bid Form is a part.

The undersigned Contractor does hereby declare and stipulate that this offer is made in good faith without collusion or connection to any person(s) providing an offer for the same work, and that it is made in pursuance of, and subject to, all terms and conditions of the Instructions to Bidders, the Specifications, and all other Solicitation Documents, all of which have been examined by the undersigned.

The Contractor also agrees that if awarded the Contract, to provide insurance certificates within ten (10) working days of the date of Notification of Award. Submittal of this offer will be taken by the Owner as a binding covenant that the Contractor will be prepared to complete the project in its entirety.

The Owner reserves the right to make the award on the basis of the offer deemed most favorable, to waive any formalities or technicalities and to reject any or all offers. It is further agreed that this offer may not be withdrawn for a period of sixty (60) calendar days after closing time. Submission of clarifications and revised offers automatically establish a new thirty day (30) period.

Prices in the bid proposal have not knowingly been disclosed with another provider and will not be prior to award.

- Prices in this bid proposal have been arrived at independently, without consultation, communication or agreement for the purpose of restricting competition.
- No attempt has been made nor will be to induce any other person or firm to submit a bid proposal for the purpose of restricting competition.
- The individual signing this bid proposal certifies they are a legal agent of the offeror, authorized to represent the offeror and is legally responsible for the offer with regard to supporting documentation and prices provided.
- Direct purchases by the City of Grand Junction are tax exempt from Colorado Sales or Use Tax. Tax exempt No. 98-03544. The undersigned certifies that no Federal, State, County or Municipal tax will be added to the above quoted prices.
- City of Grand Junction payment terms shall be Net 30 days.
- Prompt payment discount of _____ percent of the net dollar will be offered to the Owner if the invoice is paid within _____ days after the receipt of the invoice. The Owner reserves the right to take into account any such discounts when determining the bid award that are no less than Net 10 days.

RECEIPT OF ADDENDA: the undersigned Contractor acknowledges receipt of Addenda to the Solicitation, Specifications, and other Contract Documents.

State number of Addenda received: _____.

It is the responsibility of the Bidder to ensure all Addenda have been received and acknowledged.

By signing below, the Undersigned agree to comply with all terms and conditions contained herein.

Company: _____

Authorized Signature: _____

Title: _____

The undersigned Bidder proposes to subcontract the following portion of Work:

| <u>Name & address of Sub-Contractor</u> | <u>Description of work to be performed</u> | <u>% of Contract</u> |
|---|--|--------------------------|
| _____ | _____ | _____ |
| _____ | _____ | _____ |
| _____ | _____ | _____ |
| _____ | _____ | _____ |

The undersigned Bidder acknowledges the right of the City to reject any and all Bids submitted and to waive informalities and irregularities therein in the City's sole discretion.

By submission of the Bid, each Bidder certifies, and in the case of a joint Bid each party thereto certifies as to his own organization, that this Bid has been arrived at independently, without collusion, consultation, communication, or agreement as to any matter relating to this Bid with any other Bidder or with any competitor.

**OPTION 1 (Columbine & Hawthorne Parks)
 Bid Schedule Parks Pedestrian Lighting Improvements Project:**

| Item No. | CDOT, City Ref. | Description | Quantity | Units | Unit Price | Total Price |
|----------|-----------------|---|----------|-------|------------|--------------|
| 1 | | Remove Existing Lights, Foundation, and Equipment | 1 | LS | \$ _____ | \$ _____ |
| 2 | | 2 Inch Electrical Conduit (Plastic) | 5,042 | LF | \$ _____ | \$ _____ |
| 3 | | Type Two Pull Box (Electric) | 57 | EA | \$ _____ | \$ _____ |
| 4 | | Wiring | 1 | LS | \$ _____ | \$ _____ |
| 5 | | ALED-5T-78-N-USA | 45 | EA | \$ _____ | \$ _____ |
| 6 | | Philips Gullwing LED GL18-SB | 3 | EA | \$ _____ | \$ _____ |
| 7 | | Philips Gullwing LED GL18-SB2 | 2 | EA | \$ _____ | \$ _____ |
| 8 | | Philips Gullwing LED GL18-SB4 | 2 | EA | \$ _____ | \$ _____ |
| 9 | | Hubbell Luminaire | 0 | EA | \$ _____ | \$ _____ |
| 10 | | Light Standard Foundation (Special) | 45 | EA | \$ _____ | \$ _____ |
| 11 | | Light Standard Foundation (Special Parking Area) | 7 | EA | \$ _____ | \$ _____ |
| 12 | | Lighting Controller | 1 | EA | \$ _____ | \$ _____ |
| 13 | | Leviton1GM53-GY Box with WM1D-SGY | 0 | EA | \$ _____ | \$ _____ |
| 14 | | Vandal Stop AA-EB-3R | 0 | EA | \$ _____ | \$ _____ |
| 15 | | Turf Restoration | 1 | LS | \$ _____ | \$ _____ |
| 16 | | Mobilization | 1 | LS | \$ _____ | \$ _____ |
| MCR | | Minor Contract Revisions | --- | --- | --- | \$ 15,000.00 |

Bid Amount: \$ _____

Bid Amount: _____ **dollars**

| |
|------------------------|
| Bidder Name: |
| Bidder Phone #: |

**OPTION 2 (Columbine, Hawthorne & Sherwood Parks)
 Bid Schedule Parks Pedestrian Lighting Improvements Project:**

| Item No. | CDOT, City Ref. | Description | Quantity | Units | Unit Price | Total Price |
|--------------------|-----------------|---|----------|-------|------------|-----------------|
| 1 | | Remove Existing Lights, Foundation, and Equipment | 1 | LS | \$ _____ | \$ _____ |
| 2 | | 2 Inch Electrical Conduit (Plastic) | 5,042 | LF | \$ _____ | \$ _____ |
| 3 | | Type Two Pull Box (Electric) | 57 | EA | \$ _____ | \$ _____ |
| 4 | | Wiring | 1 | LS | \$ _____ | \$ _____ |
| 5 | | ALED-5T-78-N-USA | 45 | EA | \$ _____ | \$ _____ |
| 6 | | Philips Gullwing LED GL18-SB | 3 | EA | \$ _____ | \$ _____ |
| 7 | | Philips Gullwing LED GL18-SB2 | 2 | EA | \$ _____ | \$ _____ |
| 8 | | Philips Gullwing LED GL18-SB4 | 2 | EA | \$ _____ | \$ _____ |
| 9 | | Hubbell Luminaire | 6 | EA | \$ _____ | \$ _____ |
| 10 | | Light Standard Foundation (Special) | 45 | EA | \$ _____ | \$ _____ |
| 11 | | Light Standard Foundation (Special Parking Area) | 7 | EA | \$ _____ | \$ _____ |
| 12 | | Lighting Controller | 1 | EA | \$ _____ | \$ _____ |
| 13 | | Leviton 1GM53-GY Box with WM1D-SGY | 4 | EA | \$ _____ | \$ _____ |
| 14 | | Vandal Stop AA-EB-3R | 4 | EA | \$ _____ | \$ _____ |
| 15 | | Turf Restoration | 1 | LS | \$ _____ | \$ _____ |
| 16 | | Mobilization | 1 | LS | \$ _____ | \$ _____ |
| MCR | | Minor Contract Revisions | --- | --- | --- | \$ 15,000.00 |
| Bid Amount: | | | | | | \$ _____ |

Bid Amount:

dollars

| |
|------------------------|
| Bidder Name: |
| Bidder Phone #: |



Purchasing Division

ADDENDUM NO. 1

DATE: October 15, 2024
FROM: City of Grand Junction Purchasing Division
TO: All Offerors
RE: Parks Pedestrian Lighting Improvements

Offerors responding to the above referenced solicitation are hereby instructed that the requirements have been clarified, modified, superseded, and supplemented as to this date as hereinafter described.

Please make note of the following clarifications:

1. Question: Who will do the As-Builts?

Answer: The Contractor completes As-Builts consisting of an electronic format of the provided construction drawings with redlines. Redlines should include accurate footage, alterations to alignment as well as other relevant information. Below is an example of an acceptable As-Built.

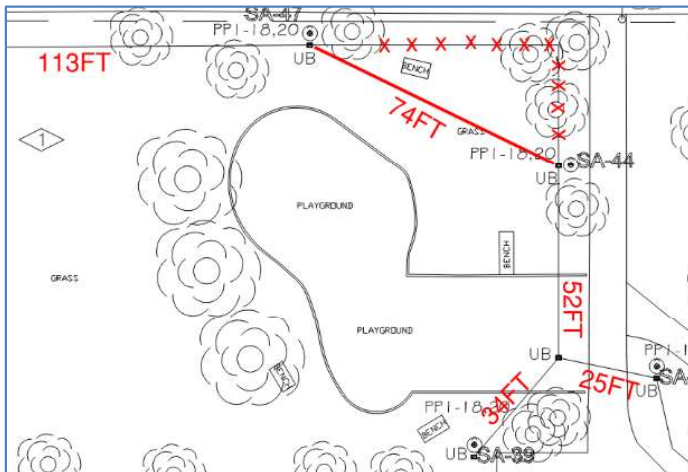

2. Question: Does the City want the removed materials?

Answer: No, please legally dispose of any removed materials.

3. Site Access: If an Offeror would like access to locked areas where the electric panels are located, please contact the City Purchasing Representative at dollyd@gjcity.org after 10/20/24.

4. Irrigation Maps: The irrigation GIS data is available on the City GIS Utilities Map (<https://external-gis.gjcity.org/Utilities Map External/>). Turn on the Parks Irrigation layer by clicking on the check box by it and the Storm & Irrigation layer, in the Layer List.

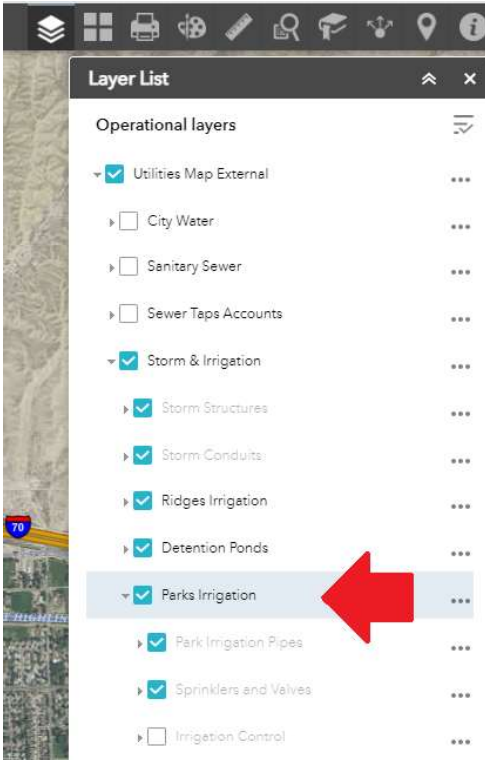

The following maps are an overlay of the Project's proposed alignment with the City's GIS irrigation data. All locations are approximate and should be field verified by the Contractor.

The original solicitation for the project noted above is amended as noted. All other conditions of the subject remain the same.

Respectfully,

Dolly Daniels, Senior Buyer
City of Grand Junction, Colorado

Hawthorne Park



- Irrigation Mainline
- Irrigation Lateral
- Sprinkler
- Valve
- Proposed Lighting Conduit
- Proposed Light Pedestal

Columbine Park

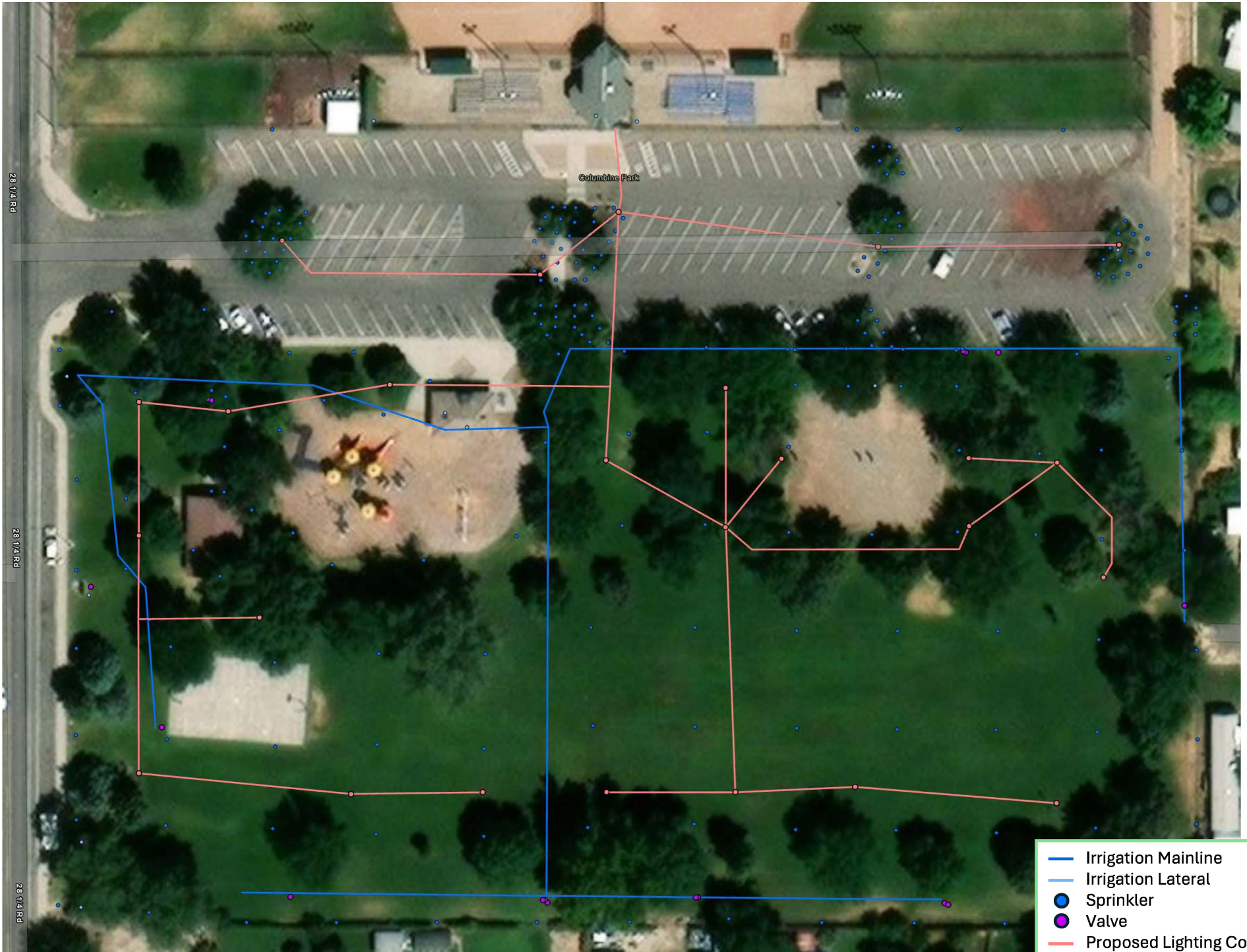

28 1/4 RD

28 1/4 RD

28 1/4 RD

- Irrigation Mainline
- Irrigation Lateral
- Sprinkler
- Valve
- Proposed Lighting Conduit
- Proposed Light Pedestal



Purchasing Division

ADDENDUM NO. 2

DATE: October 22, 2024

FROM: City of Grand Junction Purchasing Division

TO: All Offerors

RE: Parks Pedestrian Lighting Improvements IFB-5521-24-DD

Offerors responding to the above referenced solicitation are hereby instructed that the requirements have been clarified, modified, superseded, and supplemented as to this date as hereinafter described.

Please make note of the following clarifications:

1. **Question:** Can the City expand on Item #2 under the dripline of the trees? Is open excavation possible? Or will it need to be bored in?
Answer: No, when under tree canopy, also referred to as dripline, conduit must be placed by boring methods only. This is to protect the tree roots from damage.
2. **Question:** Can the same Contractor bid both options 1 and 2? Or is it one or the other?
Answer: The same Contractor can bid both options 1 and 2.
3. **Question:** The detail shows 36" bury depth but I believe code is 24". Will 24" be acceptable?"
Answer: Yes, The construction drawings indicate various depths for conduit (18", 24" and 36"). For simplicity, the minimum depth for conduit placement is 24".

The original solicitation for the project noted above is amended as noted. All other conditions of the subject remain the same.

Respectfully,

A handwritten signature in blue ink that reads "Dolly Daniels".

Dolly Daniels, Senior Buyer

City of Grand Junction, Colorado



NOTICE OF AWARD

Date: December 30, 2024
Company: CC Enterprises – Traffic Control Specialists, Inc.
Project: Parks Pedestrian Lighting Improvements IFB-5521-24-DD

You have been awarded the City of Grand Junction Contract for the Parks Pedestrian Lighting Improvements (IFB-5521-24-DD) Option 2 inclusive of Columbine, Hawthorne, and Sherwood Parks for a lump sum fee of **\$405,326.50**.

Please notify Evan Sales, Project Engineer at 970-244-1558 or evan.sales@gjcity.org for project scheduling and return to the City Purchasing Division an acknowledged copy of this Notice of Award, signed Contract and Insurance Certificate, as per the contract documents.

CITY OF GRAND JUNCTION, COLORADO

DocuSigned by:
Duane Hoff Jr., Contract Administrator - City of Grand Junction
1/10/2025
Duane Hoff, Contract Administrator

SUPPLIER ACKNOWLEDGEMENT

Receipt of this Notice to Award is hereby acknowledged:

Company: CC Enterprises - Traffic Control Specialists, Inc.
By: *Cindy York*
DF9FCDD8E6C442E...
Title: President
Date: 1/10/2025

4. Contractor's Bid Form

Project: **IFB-5521-24-DD "Parks Pedestrian Lighting Improvements"**

Bid Date: 10/30/2024

Bidding Company: CC Enterprises-Traffic Control Specialists, Inc

Name of Authorized Agent: JEFF YORK

Email jeff@ccenttcs.com

Telephone 970 242-0669 Address 830 21 1/2 Road

City Grand Junction State CO Zip 81505

The undersigned Bidder, in compliance with the Invitation for Bids, having examined the Instruction to Bidders, General Contract Conditions, Statement of Work, Specifications, and any and all Addenda thereto, having investigated the location of, and conditions affecting the proposed work, hereby proposes to furnish all labor, materials and supplies, and to perform all work for the Project in accordance with Contract Documents, within the time set forth and at the prices stated below. These prices are to cover all expenses incurred in performing the work required under the Contract Documents, of which this Contractor's Bid Form is a part.

The undersigned Contractor does hereby declare and stipulate that this offer is made in good faith without collusion or connection to any person(s) providing an offer for the same work, and that it is made in pursuance of, and subject to, all terms and conditions of the Instructions to Bidders, the Specifications, and all other Solicitation Documents, all of which have been examined by the undersigned.

The Contractor also agrees that if awarded the Contract, to provide insurance certificates within ten (10) working days of the date of Notification of Award. Submittal of this offer will be taken by the Owner as a binding covenant that the Contractor will be prepared to complete the project in its entirety.

The Owner reserves the right to make the award on the basis of the offer deemed most favorable, to waive any formalities or technicalities and to reject any or all offers. It is further agreed that this offer may not be withdrawn for a period of sixty (60) calendar days after closing time. Submission of clarifications and revised offers automatically establish a new thirty day (30) period.

Prices in the bid proposal have not knowingly been disclosed with another provider and will not be prior to award.

- Prices in this bid proposal have been arrived at independently, without consultation, communication or agreement for the purpose of restricting competition.
- No attempt has been made nor will be to induce any other person or firm to submit a bid proposal for the purpose of restricting competition.
- The individual signing this bid proposal certifies they are a legal agent of the offeror, authorized to represent the offeror and is legally responsible for the offer with regard to supporting documentation and prices provided.
- Direct purchases by the City of Grand Junction are tax exempt from Colorado Sales or Use Tax. Tax exempt No. 98-03544. The undersigned certifies that no Federal, State, County or Municipal tax will be added to the above quoted prices.
- City of Grand Junction payment terms shall be Net 30 days.
- Prompt payment discount of 0.00 percent of the net dollar will be offered to the Owner if the invoice is paid within N/A days after the receipt of the invoice. The Owner reserves the right to take into account any such discounts when determining the bid award that are no less than Net 10 days.

RECEIPT OF ADDENDA: the undersigned Contractor acknowledges receipt of Addenda to the Solicitation, Specifications, and other Contract Documents.

State number of Addenda received: 2

It is the responsibility of the Bidder to ensure all Addenda have been received and acknowledged.

By signing below, the Undersigned agree to comply with all terms and conditions contained herein.

Company: CC Enterprises-Traffic Control Specialists, Inc

Authorized Signature: Jeff York

Title: Estimator

The undersigned Bidder proposes to subcontract the following portion of Work:

| <u>Name & address of Sub-Contractor</u> | <u>Description of work to be performed</u> | <u>% of Contract</u> |
|---|--|--------------------------|
| <u>Brenton Services</u> | <u>Electrician / Material supply</u> | <u>45%</u> |
| <u> </u> | <u> </u> | <u> </u> |
| <u> </u> | <u> </u> | <u> </u> |
| <u> </u> | <u> </u> | <u> </u> |

The undersigned Bidder acknowledges the right of the City to reject any and all Bids submitted and to waive informalities and irregularities therein in the City's sole discretion.

By submission of the Bid, each Bidder certifies, and in the case of a joint Bid each party thereto certifies as to his own organization, that this Bid has been arrived at independently, without collusion, consultation, communication, or agreement as to any matter relating to this Bid with any other Bidder or with any competitor.

**OPTION 1 (Columbine & Hawthorne Parks)
 Bid Schedule Parks Pedestrian Lighting Improvements Project:**

| Item No. | CDOT, City Ref. | Description | Quantity | Units | Unit Price | Total Price |
|--------------------|-----------------|---|----------|-------|-------------|----------------------|
| 1 | | Remove Existing Lights, Foundation, and Equipment | 1 | LS | \$ 11500.00 | \$ 11500.00 |
| 2 | | 2 Inch Electrical Conduit (Plastic) | 5,042 | LF | \$ 8.25 | \$ 41596.50 |
| 3 | | Type Two Pull Box (Electric) | 57 | EA | \$ 675.00 | \$ 38475.00 |
| 4 | | Wiring | 1 | LS | \$ 72500.00 | \$ 72500.00 |
| 5 | | ALED-5T-78-N-USA | 45 | EA | \$ 875.00 | \$ 39375.00 |
| 6 | | Philips Gullwing LED GL18-SB | 3 | EA | \$ 7500.00 | \$ 22500.00 |
| 7 | | Philips Gullwing LED GL18-SB2 | 2 | EA | \$ 12500.00 | \$ 25000.00 |
| 8 | | Philips Gullwing LED GL18-SB4 | 2 | EA | \$ 22000.00 | \$ 44000.00 |
| 9 | | Hubbell Luminaire | 0 | EA | \$ | \$ |
| 10 | | Light Standard Foundation (Special) | 45 | EA | \$ 800.00 | \$ 36000.00 |
| 11 | | Light Standard Foundation (Special Parking Area) | 7 | EA | \$ 1450.00 | \$ 10150.00 |
| 12 | | Lighting Controller | 1 | EA | \$ 1800.00 | \$ 1800.00 |
| 13 | | Leviton1GM53-GY Box with WM1D-SGY | 0 | EA | \$ | \$ |
| 14 | | Vandal Stop AA-EB-3R | 0 | EA | \$ | \$ |
| 15 | | Turf Restoration | 1 | LS | \$ 1800.00 | \$ 1800.00 |
| 16 | | Mobilization | 1 | LS | \$ 40000.00 | \$ 40000.00 |
| MCR | | Minor Contract Revisions | --- | --- | --- | \$ 15,000.00 |
| Bid Amount: | | | | | | \$ 399,696.50 |

Bid Amount: Three hundred ninety-nine thousand six hundred ninety-six and fifty cents **dollars**

| |
|---|
| Bidder Name: CC Enterprises-Traffic Control Specialists, Inc |
| Bidder Phone #: 970 242-0669 |

**OPTION 2 (Columbine, Hawthorne & Sherwood Parks)
 Bid Schedule Parks Pedestrian Lighting Improvements Project:**

| Item No. | CDOT, City Ref. | Description | Quantity | Units | Unit Price | Total Price |
|--------------------|-----------------|---|----------|-------|-------------|----------------------|
| 1 | | Remove Existing Lights, Foundation, and Equipment | 1 | LS | \$ 11500.00 | \$ 11500.00 |
| 2 | | 2 Inch Electrical Conduit (Plastic) | 5,042 | LF | \$ 8.25 | \$ 41596.50 |
| 3 | | Type Two Pull Box (Electric) | 57 | EA | \$ 675.00 | \$ 38475.00 |
| 4 | | Wiring | 1 | LS | \$ 72500.00 | \$ 72500.00 |
| 5 | | ALED-5T-78-N-USA | 45 | EA | \$ 875.00 | \$ 39375.00 |
| 6 | | Philips Gullwing LED GL18-SB | 3 | EA | \$ 7500.00 | \$ 22500.00 |
| 7 | | Philips Gullwing LED GL18-SB2 | 2 | EA | \$ 12500.00 | \$ 25000.00 |
| 8 | | Philips Gullwing LED GL18-SB4 | 2 | EA | \$ 22000.00 | \$ 44000.00 |
| 9 | | Hubbell Luminaire | 6 | EA | \$ 625.00 | \$ 3750.00 |
| 10 | | Light Standard Foundation (Special) | 45 | EA | \$ 800.00 | \$ 36000.00 |
| 11 | | Light Standard Foundation (Special Parking Area) | 7 | EA | \$ 1450.00 | \$ 10150.00 |
| 12 | | Lighting Controller | 1 | EA | \$ 1800.00 | \$ 1800.00 |
| 13 | | Leviton 1GM53-GY Box with WM1D-SGY | 4 | EA | \$ 40.00 | \$ 160.00 |
| 14 | | Vandal Stop AA-EB-3R | 4 | EA | \$ 430.00 | \$ 1720.00 |
| 15 | | Turf Restoration | 1 | LS | \$ 1800.00 | \$ 1800.00 |
| 16 | | Mobilization | 1 | LS | \$ 40000.00 | \$ 40000.00 |
| MCR | | Minor Contract Revisions | --- | --- | --- | \$ 15,000.00 |
| Bid Amount: | | | | | | \$ 405,326.50 |

Bid Amount: Four hundred five thousand three hundred twenty-six and fifty cents **dollars**

| |
|---|
| Bidder Name: CC Enterprises-Traffic Control Specialists, Inc |
| Bidder Phone #: 970 242-0669 |

IFB-5521-24-DD

BID BOND

KNOW ALL MEN BY THESE PRESENTS,

that we, C C Enterprises - Traffic Control Specialists, Inc. (an individual, a partnership, X a corporation incorporated in the State of CO) as Principal, and Nationwide Mutual Insurance Company (incorporated in the State of OH) as Surety, are held and firmly bound unto the City of Grand Junction, Colorado, (hereinafter called "City") in the penal sum of Five Percent of Amount Bid dollars (\$ 5%), lawful money of the United States, for the payment of which sum we bind ourselves, our heirs, executors, administrators, successors, and assigns, jointly and severally, firmly by these presents.

THE CONDITION OF THIS OBLIGATION IS SUCH, that WHEREAS the Principal has submitted the accompanying Bid dated October 30, 2024 for construction of Parks Pedestrian Lighting Improvements Project - IFB-5521-24-DD (the Project) for the City and

WHEREAS, the City has required as a condition for receiving said Bid that the Principal deposit with the City either a cashier's check or a certified check equivalent to not less than five percent of the amount of said Bid or in lieu thereof furnish a Bid Bond for said amount conditioned that in event of a failure to execute the proposed Contract for such construction and to provide the required Performance and Payment Bonds and Insurance Certificates if the Contract be awarded to the Bidder, that said sum be paid immediately to the City as Liquidated Damages and not as a penalty for the Principal's failure to perform.

NOW, THEREFORE, if the Principal shall, within the period specified therefore, on the attached prescribed forms presented to the Bidder for signature, enter into a written Contract with the City in accordance with said Bid as accepted, and give Performance and Payment Bonds with good and sufficient Surety, or Sureties, as may be required upon the forms prescribed by the City, for the faithful performance and the proper fulfillment of said Contract, provide Certificates of Insurance as required by said Contract, and provide all other information and documentation required by the Contract Documents, then this obligation shall be void and of no effect, otherwise to remain in full force and effect. In the event suit is brought upon this bond by the City and the City prevails, the principal and surety shall pay all costs incurred by the City in such suit, including reasonable attorneys' fees and costs to be fixed by the Court.

IFB-5521-24-DD

IN WITNESS WHEREOF, the above bound parties have executed this instrument under their several seals the name and corporate seal of each corporate party being hereto affixed and duly signed by its undersigned representative pursuant to authority of its governing board.

Dated this 30th day of October, 2024.

Principal: C C Enterprises - Traffic Control Specialists, Inc.

Address: 830 21 1/2 Rd.
Grand Junction, CO 81505

Signed: By: *John York*
Title: Estimator



Surety: Nationwide Mutual Insurance Company

Address: One West Nationwide Blvd., 1-14-301
Columbus, OH 43215-2220

Signed: By: *Regina R. Hrovat*
Title: Regina R. Hrovat Attorney-in-Fact

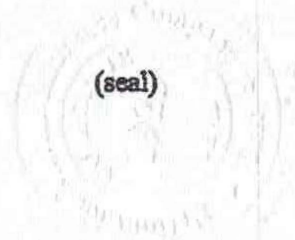

INSTRUCTIONS FOR COMPLETING BID BOND

1. The full legal name and residence of each individual executing this Bond as Principal must be inserted in the first paragraph.
2. If the Principal is a partnership, the full name of the partnership and all individuals must be inserted in the first paragraph which must recite that individuals are partners composing the partnership, and all partners must execute the Bond as individuals.
3. The State of incorporation of each corporate Principal or Surety to the Bond must be inserted in the first paragraph and the Bond must be executed under the corporate seal of said party attested by its secretary or other appropriate officer.
4. Attach a copy of the power-of-attorney for the Surety's agent.

Power of Attorney

KNOW ALL MEN BY THESE PRESENTS THAT:

Nationwide Mutual Insurance Company, an Ohio corporation

hereinafter referred to severally as the "Company" and collectively as "the Companies" does hereby make, constitute and appoint:

Regina R. Hrovat

each in their individual capacity, its true and lawful attorney-in-fact, with full power and authority to sign, seal, and execute on its behalf any and all bonds and undertakings, and other obligatory instruments of similar nature, in penalties not exceeding the sum of

UNLIMITED

Surety Bond Number: Bid Bond
Principal: C C Enterprises - Traffic Control Specialists, Inc.
Obligee: City of Grand Junction

and to bind the Company thereby, as fully and to the same extent as if such instruments were signed by the duly authorized officers of the Company; and all acts of said Attorney pursuant to the authority given are hereby ratified and confirmed.

This power of attorney is made and executed pursuant to and by authority of the following resolution duly adopted by the board of directors of the Company:

"RESOLVED, that the president, or any vice president be, and each hereby is, authorized and empowered to appoint attorneys-in-fact of the Company, and to authorize them to execute and deliver on behalf of the Company any and all bonds, forms, applications, memorandums, undertakings, recognizances, transfers, contracts of indemnity, policies, contracts guaranteeing the fidelity of persons holding positions of public or private trust, and other writings obligatory in nature that the business of the Company may require; and to modify or revoke, with or without cause, any such appointment or authority; provided, however, that the authority granted hereby shall in no way limit the authority of other duly authorized agents to sign and countersign any of said documents on behalf of the Company."

"RESOLVED FURTHER, that such attorneys-in-fact shall have full power and authority to execute and deliver any and all such documents and to bind the Company subject to the terms and limitations of the power of attorney issued to them, and to affix the seal of the Company thereto; provided, however, that said seal shall not be necessary for the validity of any such documents."

This power of attorney is signed and sealed under and by the following bylaws duly adopted by the board of directors of the Company

Execution of Instruments. Any vice president, any assistant secretary or any assistant treasurer shall have the power and authority to sign or attest all approved documents, instruments, contracts, or other papers in connection with the operation of the business of the company in addition to the chairman of the board, the chief executive officer, president, treasurer or secretary; provided, however, the signature of any of them may be printed, engraved, or stamped on any approved document, contract, instrument, or other papers of the Company.

IN WITNESS WHEREOF, the Company has caused this instrument to be sealed and duly attested by the signature of its officer the 1st day of April, 2024.

Handwritten signature of Antonio C. Albanese

Antonio C. Albanese, Vice President of Nationwide Mutual Insurance Company

ACKNOWLEDGMENT

STATE OF NEW YORK COUNTY OF KINGS: ss

On this 1st day of April, 2024, before me came the above-named officer for the Company aforesaid, to me personally known to be the officer described in and who executed the preceding instrument, and he acknowledged the execution of the same, and being by me duly sworn, deposes and says, that he is the officer of the Company aforesaid, that the seal affixed hereto is the corporate seal of said Company, and the said corporate seal and his signature were duly affixed and subscribed to said instrument by the authority and direction of said Company



Sharon Laburda
Notary Public, State of New York
No. 01LA0427007
Qualified in Kings County
Commission Expires January 3, 2028

Handwritten signature of Sharon Laburda

Notary Public
My Commission Expires
January 3, 2028

CERTIFICATE

I, Lezlie F. Chimentl, Assistant Secretary of the Company, do hereby certify that the foregoing is a full, true and correct copy of the original power of attorney issued by the Company; that the resolution included therein is a true and correct transcript from the minutes of the meetings of the boards of directors and the same has not been revoked or amended in any manner; that said Antonio C. Albanese was on the date of the execution of the foregoing power of attorney the duly elected officer of the Company, and the corporate seal and his signature as officer were duly affixed and subscribed to the said instrument by the authority of said board of directors; and the foregoing power of attorney is still in full force and effect.

IN WITNESS WHEREOF, I have hereunto subscribed my name as Assistant Secretary, and affixed the corporate seal of said Company the 30th day of October, 2024.

Handwritten signature of Lezlie F. Chimentl, Assistant Secretary

PERFORMANCE BOND

KNOW ALL MEN BY THESE PRESENTS, that we, the undersigned _____
C C Enterprises - Traffic Control Specialists, Inc. _____, a _____ Corporation _____
organized under the laws of the State of _____ CO _____, hereinafter
referred to as the "Contractor" and Nationwide Mutual Insurance Company _____
_____, a corporation organized under the laws of the State of _____ OH _____
_____, and authorized and licensed to transact business in the State of
Colorado, hereinafter referred to as the "Surety," are held and firmly bound unto the City
of Grand Junction, Colorado, hereinafter referred to as the "City", in the penal sum of
Four Hundred Five Thousand Three Hundred Twenty Six Dollars and 50/100 _____
_____ dollars (\$ 405,326.50 _____), lawful money of the United
States of America, for the payment of which sum the Contractor and Surety bind
themselves and their heirs, executors, administrators, successors and assigns, jointly
and severally by these presents.

WHEREAS, the above Contractor has on the 30th day of December,
2024, entered into a written contract with the City for furnishing all labor, materials,
equipment, tools, superintendence, and other facilities and accessories for the
construction of Parks Pedestrian Lighting Improvements Project
_____ (the "Project") and Contract No. IFB-5521-24-DD, if appropriate, in
accordance with the Contract, Special Conditions, Special Provisions, General Contract
Conditions, Contract Drawings, Specifications and all other Contract Documents
therefor which are incorporated herein by reference and made a part hereof, and are
herein referred to as the "Contract".

NOW, THEREFORE, the conditions of this performance bond are such that if the
Contractor:

1. Promptly and faithfully observes, abides by and performs each and every covenant, condition and part of said Contract, including, but not limited to, its warranty provisions, in the time and manner prescribed in the Contract, and
2. Pays the City all losses, damages (liquidated or actual, including, but not limited to, damages caused by delays in performance of the Contract), expenses, costs and attorneys' fees, that the City sustains resulting from
3. any breach or default by the Contractor under the Contract,

then this bond is void; otherwise, it shall remain in full force and effect.

IN ADDITION, if said Contractor fails to duly pay for any labor, materials, team hire, sustenance, provisions, provender, or any other supplies used or consumed by said Contractor or its subcontractors in its performance of the Work contracted to be done or fails to pay any person who supplies rental machinery, tools, or equipment, all amounts due as the result of the use of such machinery, tools or equipment in the prosecution of the work, the Surety shall pay the same in an amount not exceeding the amount of this obligation, together with interest at the rate of eight percent per annum.

PROVIDED FURTHER, that the said Surety, for value received, hereby stipulates and agrees that any and all changes in the Contract or compliance or noncompliance with the formalities in the Contract for making such changes shall not affect the Surety's obligations under this bond and the Surety hereby waives notice of any such changes. Further, Contractor and Surety acknowledge that the penal sum of this bond shall increase in accordance with approved changes to the Contract Documents without obtaining the Surety's consent up to a maximum of 20 percent of the penal sum. Any additional increases in the penal sum shall require the Surety's consent.

IN WITNESS WHEREOF, said Contractor and said Surety have executed these presents as of this 3rd day of January, 2025.



CONTRACTOR: C C Enterprises - Traffic Control Specialists, Inc.
By: [Signature]
Title: President

ATTEST: [Signature]
Secretary

SURETY: Nationwide Mutual Insurance Company
By: [Signature]
Title: Elizabeth Ostblom Attorney-in-Fact



(Accompany this Bond with the attorney-in-fact's authority from the surety to execute this Bond, certified to include the date of the Bond.)

PAYMENT BOND

KNOW ALL MEN BY THESE PRESENTS, that we, the undersigned _____
C C Enterprises - Traffic Control Specialists, Inc. _____, a Corporation organized
under the laws of the State of CO _____, hereinafter referred to as the
"Contractor" and Nationwide Mutual Insurance Company _____
_____, a corporation organized under the laws of the State of OH _____
_____, and authorized and licensed to transact business in the State of Colorado,
hereinafter referred to as the "Surety," are held and firmly bound unto the City of Grand
Junction, Colorado, hereinafter referred to as the "City," in the penal sum of _____
Four Hundred Five Thousand Three Hundred Twenty Six Dollars and 50/100
_____ dollars (\$405,326.50 _____), lawful money of the United
States of America, for the payment of which sum the Contractor and Surety bind
themselves and their heirs, executors, administrators, successors and assigns, jointly
and severally, firmly by these presents.

WHEREAS, the above Contractor has on the 30th day of December _____,
2024, entered into a written contract with the City for furnishing all labor, materials,
equipment, tools, superintendence, and other facilities and accessories for the
construction of Parks Pedestrian Lighting Improvements Project _____
_____ (the "Project") and Contract No. IFB-5521-24-DD, if appropriate, in
accordance with the Contract, Special Conditions, Special Provisions, General Contract
Conditions, Contract Drawings, Specifications and all other Contract Documents
therefor which are incorporated herein by reference and made a part hereof, and are
herein referred to as the "Contract".

NOW, THEREFORE, the condition of this payment bond obligation is such that if
the Contractor shall at all times promptly make payments of all amounts lawfully due to
all persons supplying or furnishing it or its subcontractors with labor, materials, rental
machinery, tools or equipment, used or performed in the prosecution of work provided
for in the above Contract and shall indemnify and save harmless the City to the extent
of any and all payments in connection with the carrying out of such Contract which the
City may be required to make under the law, and for all losses, damages, expenses,
costs, and attorneys' fees incurred by the City resulting from the failure of the Contractor
to make the payments discussed above, then this obligation shall be null and void,
otherwise, it shall remain in full force and effect.

PROVIDE FURTHER, that the said Surety, for value received, hereby stipulates and agrees that any and all changes in the Contract Documents, or compliance or noncompliance with the formalities in the Contract for making such changes shall not affect the Surety's obligations under this bond and the Surety hereby waives notice of any such changes. Further, Contractor and Surety acknowledge that the penal sum of this bond shall increase or decrease in accordance with approved changes to the Contract Documents without obtaining the Surety's consent up to a maximum of 20 percent of the penal sum. Any additional increases in the penal sum shall require the Surety's consent.

IN WITNESS WHEREOF, said Contractor and said Surety have executed these presents as of this 3rd day of January, 2025.



CONTRACTOR: C C Enterprises - Traffic Control Specialists, Inc.
By: *Dale York*
Title: President

ATTEST: *Dale York*
Secretary

SURETY: Nationwide Mutual Insurance Company
By: *[Signature]*
Title: Elizabeth Ostblom Attorney-in-Fact



(Accompany this Bond with the attorney-in-fact's authority from the surety to execute this Bond, certified to include the date of the Bond.)

Power of Attorney

KNOW ALL MEN BY THESE PRESENTS THAT:

Nationwide Mutual Insurance Company, an Ohio corporation

hereinafter referred to severally as the "Company" and collectively as "the Companies" does hereby make, constitute and appoint:

Elizabeth Ostblom

each in their individual capacity, its true and lawful attorney-in-fact, with full power and authority to sign, seal, and execute on its behalf any and all bonds and undertakings, and other obligatory instruments of similar nature, in penalties not exceeding the sum of

UNLIMITED

Surety Bond Number: 7901235095
Principal: C C Enterprises - Traffic Control Specialists, Inc.
Obligee: City of Grand Junction

and to bind the Company thereby, as fully and to the same extent as if such instruments were signed by the duly authorized officers of the Company; and all acts of said Attorney pursuant to the authority given are hereby ratified and confirmed.

This power of attorney is made and executed pursuant to and by authority of the following resolution duly adopted by the board of directors of the Company:

"RESOLVED, that the president, or any vice president be, and each hereby is, authorized and empowered to appoint attorneys-in-fact of the Company, and to authorize them to execute and deliver on behalf of the Company any and all bonds, forms, applications, memorandums, undertakings, recognizances, transfers, contracts of indemnity, policies, contracts guaranteeing the fidelity of persons holding positions of public or private trust, and other writings obligatory in nature that the business of the Company may require; and to modify or revoke, with or without cause, any such appointment or authority; provided, however, that the authority granted hereby shall in no way limit the authority of other duly authorized agents to sign and countersign any of said documents on behalf of the Company."

"RESOLVED FURTHER, that such attorneys-in-fact shall have full power and authority to execute and deliver any and all such documents and to bind the Company subject to the terms and limitations of the power of attorney issued to them, and to affix the seal of the Company thereto; provided, however, that said seal shall not be necessary for the validity of any such documents."

This power of attorney is signed and sealed under and by the following bylaws duly adopted by the board of directors of the Company.

Execution of Instruments. Any vice president, any assistant secretary or any assistant treasurer shall have the power and authority to sign or attest all approved documents, instruments, contracts, or other papers in connection with the operation of the business of the company in addition to the chairman of the board, the chief executive officer, president, treasurer or secretary; provided, however, the signature of any of them may be printed, engraved, or stamped on any approved document, contract, instrument, or other papers of the Company.

IN WITNESS WHEREOF, the Company has caused this instrument to be sealed and duly attested by the signature of its officer the 1st day of April, 2024.

Antonio C. Albanese, Vice President of Nationwide Mutual Insurance Company

ACKNOWLEDGMENT

STATE OF NEW YORK COUNTY OF KINGS: ss

On this 1st day of April, 2024, before me came the above-named officer for the Company aforesaid, to me personally known to be the officer described in and who executed the preceding instrument, and he acknowledged the execution of the same, and being by me duly sworn, deposes and says, that he is the officer of the Company aforesaid, that the seal affixed hereto is the corporate seal of said Company, and the said corporate seal and his signature were duly affixed and subscribed to said instrument by the authority and direction of said Company.

Sharon Laburda
Notary Public, State of New York
No. 01LA6427697
Qualified in Kings County
Commission Expires January 3, 2026

Notary Public
My Commission Expires
January 3, 2026

CERTIFICATE

I, Lezile F. Chimenti, Assistant Secretary of the Company, do hereby certify that the foregoing is a full, true and correct copy of the original power of attorney issued by the Company; that the resolution included therein is a true and correct transcript from the minutes of the meetings of the boards of directors and the same has not been revoked or amended in any manner; that said Antonio C. Albanese was on the date of the execution of the foregoing power of attorney the duly elected officer of the Company, and the corporate seal and his signature as officer were duly affixed and subscribed to the said instrument by the authority of said board of directors; and the foregoing power of attorney is still in full force and effect.

IN WITNESS WHEREOF, I have hereunto subscribed my name as Assistant Secretary, and affixed the corporate seal of said Company this 3rd day of January, 2025.



PERFORMANCE BOND

KNOW ALL MEN BY THESE PRESENTS, that we, the undersigned _____
C C Enterprises - Traffic Control Specialists, Inc. _____, a _____ Corporation
organized under the laws of the State of _____ CO _____, hereinafter
referred to as the "Contractor" and Nationwide Mutual Insurance Company
_____, a corporation organized under the laws of the State of _____ OH
_____, and authorized and licensed to transact business in the State of
Colorado, hereinafter referred to as the "Surety," are held and firmly bound unto the City
of Grand Junction, Colorado, hereinafter referred to as the "City", in the penal sum of
Four Hundred Five Thousand Three Hundred Twenty Six Dollars and 50/100
_____ dollars (\$ 405,326.50 _____), lawful money of the United
States of America, for the payment of which sum the Contractor and Surety bind
themselves and their heirs, executors, administrators, successors and assigns, jointly
and severally by these presents.

WHEREAS, the above Contractor has on the 30th day of December,
2024, entered into a written contract with the City for furnishing all labor, materials,
equipment, tools, superintendence, and other facilities and accessories for the
construction of Parks Pedestrian Lighting Improvements Project
_____ (the "Project") and Contract No. IFB-5521-24-DD, if appropriate, in
accordance with the Contract, Special Conditions, Special Provisions, General Contract
Conditions, Contract Drawings, Specifications and all other Contract Documents
therefor which are incorporated herein by reference and made a part hereof, and are
herein referred to as the "Contract".

NOW, THEREFORE, the conditions of this performance bond are such that if the
Contractor:

1. Promptly and faithfully observes, abides by and performs each and every
covenant, condition and part of said Contract, including, but not limited to,
its warranty provisions, in the time and manner prescribed in the Contract,
and
2. Pays the City all losses, damages (liquidated or actual, including, but not
limited to, damages caused by delays in performance of the Contract),
expenses, costs and attorneys' fees, that the City sustains resulting from
3. any breach or default by the Contractor under the Contract,

then this bond is void; otherwise, it shall remain in full force and effect.

IN ADDITION, if said Contractor fails to duly pay for any labor, materials, team hire, sustenance, provisions, provender, or any other supplies used or consumed by said Contractor or its subcontractors in its performance of the Work contracted to be done or fails to pay any person who supplies rental machinery, tools, or equipment, all amounts due as the result of the use of such machinery, tools or equipment in the prosecution of the work, the Surety shall pay the same in an amount not exceeding the amount of this obligation, together with interest at the rate of eight percent per annum.

PROVIDED FURTHER, that the said Surety, for value received, hereby stipulates and agrees that any and all changes in the Contract or compliance or noncompliance with the formalities in the Contract for making such changes shall not affect the Surety's obligations under this bond and the Surety hereby waives notice of any such changes. Further, Contractor and Surety acknowledge that the penal sum of this bond shall increase in accordance with approved changes to the Contract Documents without obtaining the Surety's consent up to a maximum of 20 percent of the penal sum. Any additional increases in the penal sum shall require the Surety's consent.

IN WITNESS WHEREOF, said Contractor and said Surety have executed these presents as of this 3rd day of January, 2025.



CONTRACTOR: C C Enterprises - Traffic Control Specialists, Inc.
Dale York
President

ATTEST: Dale York
Secretary

SURETY: Nationwide Mutual Insurance Company
By: [Signature]
Title: Elizabeth Ostblom Attorney-in-Fact



(Accompany this Bond with the attorney-in-fact's authority from the surety to execute this Bond, certified to include the date of the Bond.)

PAYMENT BOND

KNOW ALL MEN BY THESE PRESENTS, that we, the undersigned _____
C C Enterprises - Traffic Control Specialists, Inc. _____, a _____ Corporation _____ organized
under the laws of the State of _____ CO _____, hereinafter referred to as the
"Contractor" and _____ Nationwide Mutual Insurance Company _____
_____, a corporation organized under the laws of the State of _____ OH _____
_____, and authorized and licensed to transact business in the State of Colorado,
hereinafter referred to as the "Surety," are held and firmly bound unto the City of Grand
Junction, Colorado, hereinafter referred to as the "City," in the penal sum of _____
Four Hundred Five Thousand Three Hundred Twenty Six Dollars and 50/100 _____
_____ dollars (\$405,326.50 _____), lawful money of the United
States of America, for the payment of which sum the Contractor and Surety bind
themselves and their heirs, executors, administrators, successors and assigns, jointly
and severally, firmly by these presents.

WHEREAS, the above Contractor has on the 30th day of December,
2024, entered into a written contract with the City for furnishing all labor, materials,
equipment, tools, superintendence, and other facilities and accessories for the
construction of Parks Pedestrian Lighting Improvements Project
_____ (the "Project") and Contract No. IFB-5521-24-DD, if appropriate, in
accordance with the Contract, Special Conditions, Special Provisions, General Contract
Conditions, Contract Drawings, Specifications and all other Contract Documents
therefor which are incorporated herein by reference and made a part hereof, and are
herein referred to as the "Contract".

NOW, THEREFORE, the condition of this payment bond obligation is such that if
the Contractor shall at all times promptly make payments of all amounts lawfully due to
all persons supplying or furnishing it or its subcontractors with labor, materials, rental
machinery, tools or equipment, used or performed in the prosecution of work provided
for in the above Contract and shall indemnify and save harmless the City to the extent
of any and all payments in connection with the carrying out of such Contract which the
City may be required to make under the law, and for all losses, damages, expenses,
costs, and attorneys' fees incurred by the City resulting from the failure of the Contractor
to make the payments discussed above, then this obligation shall be null and void,
otherwise, it shall remain in full force and effect.

PROVIDE FURTHER, that the said Surety, for value received, hereby stipulates and agrees that any and all changes in the Contract Documents, or compliance or noncompliance with the formalities in the Contract for making such changes shall not affect the Surety's obligations under this bond and the Surety hereby waives notice of any such changes. Further, Contractor and Surety acknowledge that the penal sum of this bond shall increase or decrease in accordance with approved changes to the Contract Documents without obtaining the Surety's consent up to a maximum of 20 percent of the penal sum. Any additional increases in the penal sum shall require the Surety's consent.

IN WITNESS WHEREOF, said Contractor and said Surety have executed these presents as of this 3rd day of January, 2025.



CONTRACTOR: C C Enterprises - Traffic Control Specialists, Inc.

By: *[Signature]*
Title: President

ATTEST: *[Signature]*
Secretary

SURETY: Nationwide Mutual Insurance Company

By: *[Signature]*
Title: Elizabeth Ostblom Attorney-in-Fact



(Accompany this Bond with the attorney-in-fact's authority from the surety to execute this Bond, certified to include the date of the Bond.)

Power of Attorney

KNOW ALL MEN BY THESE PRESENTS THAT:

Nationwide Mutual Insurance Company, an Ohio corporation

hereinafter referred to severally as the "Company" and collectively as "the Companies" does hereby make, constitute and appoint:

Elizabeth Ostblom

each in their individual capacity, its true and lawful attorney-in-fact, with full power and authority to sign, seal, and execute on its behalf any and all bonds and undertakings, and other obligatory instruments of similar nature, in penalties not exceeding the sum of

UNLIMITED

Surety Bond Number: 7901235095
Principal: C C Enterprises - Traffic Control Specialists, Inc.
Obligee: City of Grand Junction

and to bind the Company thereby, as fully and to the same extent as if such Instruments were signed by the duly authorized officers of the Company; and all acts of said Attorney pursuant to the authority given are hereby ratified and confirmed.

This power of attorney is made and executed pursuant to and by authority of the following resolution duly adopted by the board of directors of the Company:

"RESOLVED, that the president, or any vice president be, and each hereby is, authorized and empowered to appoint attorneys-in-fact of the Company, and to authorize them to execute and deliver on behalf of the Company any and all bonds, forms, applications, memorandums, undertakings, recognizances, transfers, contracts of indemnity, policies, contracts guaranteeing the fidelity of persons holding positions of public or private trust, and other writings obligatory in nature that the business of the Company may require; and to modify or revoke, with or without cause, any such appointment or authority; provided, however, that the authority granted hereby shall in no way limit the authority of other duly authorized agents to sign and countersign any of said documents on behalf of the Company."

"RESOLVED FURTHER, that such attorneys-in-fact shall have full power and authority to execute and deliver any and all such documents and to bind the Company subject to the terms and limitations of the power of attorney issued to them, and to affix the seal of the Company thereto; provided, however, that said seal shall not be necessary for the validity of any such documents."

This power of attorney is signed and sealed under and by the following bylaws duly adopted by the board of directors of the Company.

Execution of Instruments. Any vice president, any assistant secretary or any assistant treasurer shall have the power and authority to sign or attest all approved documents, instruments, contracts, or other papers in connection with the operation of the business of the company in addition to the chairman of the board, the chief executive officer, president, treasurer or secretary; provided, however, the signature of any of them may be printed, engraved, or stamped on any approved document, contract, instrument, or other papers of the Company.

IN WITNESS WHEREOF, the Company has caused this instrument to be sealed and duly attested by the signature of its officer the 1st day of April, 2024.

Antonio C. Albanese, Vice President of Nationwide Mutual Insurance Company

ACKNOWLEDGMENT

STATE OF NEW YORK COUNTY OF KINGS: ss

On this 1st day of April, 2024, before me came the above-named officer for the Company aforesaid, to me personally known to be the officer described in and who executed the preceding Instrument, and he acknowledged the execution of the same, and being by me duly sworn, deposes and says, that he is the officer of the Company aforesaid, that the seal affixed hereto is the corporate seal of said Company, and the said corporate seal and his signature were duly affixed and subscribed to said instrument by the authority and direction of said Company.



Sharon Laburda
Notary Public, State of New York
No. 01LA6427697
Qualified in Kings County
Commission Expires January 3, 2026

Notary Public
My Commission Expires
January 3, 2026

CERTIFICATE

I, Lezlie F. Chimlenti, Assistant Secretary of the Company, do hereby certify that the foregoing is a full, true and correct copy of the original power of attorney issued by the Company; that the resolution included therein is a true and correct transcript from the minutes of the meetings of the boards of directors and the same has not been revoked or amended in any manner; that said Antonio C. Albanese was on the date of the execution of the foregoing power of attorney the duly elected officer of the Company, and the corporate seal and his signature as officer were duly affixed and subscribed to the said instrument by the authority of said board of directors; and the foregoing power of attorney is still in full force and effect.

IN WITNESS WHEREOF, I have hereunto subscribed my name as Assistant Secretary, and affixed the corporate seal of said Company this 3rd day of January, 2025.