



Invitation for Bids
IFB-4128-15-NJ

**Tandem Dump Truck
With V-Box**

RESPONSES DUE:

November 17, 2015
Prior to 3:30 PM MST

Accepting Electronic Responses Only
**Responses Only Submitted Through the Rocky Mountain E-
Purchasing System**

www.rockymountainbidsystem.com

(Purchasing Representative does not have access or control of the vendor side of RMEPS.
If website or other problems arise during response submission, vendor **MUST** contact
RMEPS to resolve issue prior to the response deadline. 800-835-4603).

PURCHASING REPRESENTATIVE:

Nicholas C Jones, Buyer
Phone (970)244-1533
Nickj@gjcity.org

This document has been developed specifically to solicit competitive responses for this solicitation, and may not be the same as previous City of Grand Junction/Mesa County solicitations. All vendors are urged to thoroughly review this solicitation prior to responding. Submittal by **FAX, EMAIL OR HARD COPY IS NOT ACCEPTABLE** for this solicitation.

Table of Contents

Section I.	INTRODUCTION
Section II.	INSTRUCTION TO BIDDERS
Section III.	GENERAL TERMS AND CONDITIONS
Section IV.	SPECIFICATION/COMPLIANCE FORM
Section V.	BID FORM
	ATTACHMENT A
	ATTACHMENT B

SECTION I. INTRODUCTION

A. Purpose: The Owner is interested in purchasing **One (1), New, Current Model Year, CNG Powered, 4x2 Tandem Axle, Rear Dual Wheel, Dump Truck with Salt Box and Snow Plow.** In comparing responses, consideration will not be confined to price only. The successful vendor will be one whose product is judged to best serve the interests of the Owner.

B. The Owner: The Owner is the City of Grand Junction, Colorado and is referred to throughout this Solicitation. The term Owner means the Owner or his authorized representative.

C. Timeline:

- | | |
|---|-------------------|
| • Invitation for Bids Available | October 27, 2015 |
| • Last Day for Questions, prior to 12:00 PM MST | November 12, 2015 |
| • Addenda Issued (If required) by: | November 13, 2015 |
| • Responses Due prior to 3:30 PM MST | November 17, 2015 |

SECTION II. INSTRUCTIONS TO BIDDER

A. Equipment Details and Literature Required: *Each bid shall be submitted in electronic format only, and only through the Rocky Mountain E-Purchasing website (www.rockymountainbidsystem.com). This site offers both “free” and “paying” registration options that allow for full access of the Owner’s documents and for electronic submission of proposals. (Note: “free” registration may take up to 24 hours to process. Please Plan accordingly.)* Please view our “**Electronic Vendor Registration Guide**” at <http://www.gjcity.org/BidOpenings.aspx> for details. (Purchasing Representative does not have access or control of the vendor side of RMEPS. If website or other problems arise during response submission, vendor **MUST** contact RMEPS to resolve issue prior to the response deadline. **800-835-4603**). All bids must be accompanied by specification sheets and/or descriptive brochures showing the detailed specifications of the equipment you propose to furnish for the bid price. All equipment will be furnished with all standard equipment as described by the literature presented with the bid proposal. References to items shown on the literature, which the bidder does not intend to supply, must be so noted in writing as an amendment to the literature. It is the bidder’s responsibility to provide specific equipment details to permit proper evaluation of the bid; failure to do so may result in disqualification of the bid.

The body, finish, fittings and all components shall be the latest and most current model, and shall not have been used as a demonstrator or any other service, and shall be factory standard in all respects not in conflict with the attached Owner bid specifications. If the Owner is interested in a demonstrator, such information will be supplied in the bid specifications.

The design of the vehicle/equipment must be such that it does not hamper or restrict subsequent installation and use of emergency equipment, such as emergency lights and backup alarms.

When specifications for particular items are not defined, manufacturer’s standards are satisfactory, provided the item is required for the proper performance of the equipment.

B. Emissions Standards: As applicable by law: Vehicles/Equipment must be supplied with manufacturer’s standard equipment and all devices necessary to be in compliance with the most current State of Colorado code, and the Federal Motor Vehicle Safety Standards. Vehicle must comply with all Federal and Colorado motor vehicle pollution control requirements and be capable of passing State emissions tests. Delivery must include any EPA documentation. Vehicles and/or Equipment not meeting the aforementioned standards will not be accepted.

C. **Error and Omissions:** If the bidder discovers any errors, omissions, lack of clarity or desires further information about the specifications, the Purchasing Representative should be contacted immediately.

D. **Guarantee:** All equipment, units and components shall be guaranteed in accordance with the following clauses:

a. Guarantee that the equipment offered is free from defects in design and construction and that it will give continuous and efficient service under normal conditions for the duration of the warranty period.

b. Guarantee that the equipment or vehicle is the manufacturer's standard design in construction and that no changes or substitutes have been made, unless otherwise stated.

E. **Warranty:** All equipment bids must include the manufacturer's standard warranty, and this information shall be provided with the bid. Additional or extended warranties may be requested; if so, specific warranty information must be provided with the bid. The warranty period shall commence after the equipment/vehicle is received and accepted by the Owner, unless special provisions are made with the successful provider.

F. **Operating/Maintenance Instruction:** Where specifically requested in the specifications, the bidder/supplier will instruct a given number of Owner employees in the operation and maintenance of equipment. The instructions shall be of the scope and length to orient personnel in: operating techniques, safety precautions, frequent inspection and servicing requirements, mechanical adjustments and repairs unique to the equipment or vehicle. Instructions will be required at the Owner site specified and provided on a schedule arranged after delivery of the equipment. If available, manufacturer shall provide an operational safety video for specialty equipment (chippers, stump cutters, leaf machines, etc.) Instruction schedules will be agreed to prior to invoice payment.

G. **Delivery Date:** All bids must be submitted with a delivery date.

H. **Pre-delivery:** Prior to delivery, new equipment/vehicle must be completely serviced in accordance with standard new vehicle "Make Ready" and to the manufacturer's specifications.

I. **Delivery:** All costs for delivery of the new unit will be assumed by the Bidder and included in the net price. Unless stated elsewhere in this bid document, all deliveries will be made to the City of Grand Junction, Fleet Services, 333 West Avenue, Building C, Grand Junction, CO 81501.

J. **Prices:** Prices quoted shall exclude Federal Excise and State taxes. Prices quoted shall be F.O.B. City of Grand Junction, CO 81501.

K. **Final Payment:** Final payment for equipment and vehicles delivered under these specifications will not be made until all terms and conditions have been satisfied.

L. **Bid Evaluation Criteria:** The evaluation of this bid will be based on, but not limited to, the following: Compliance with specifications; proven performance; ease of operation, life-cycle cost, net cost, supplier performance history; delivery time; compatibility with existing equipment, parts or supplies; service/parts availability; and, advantageous superior design features.

M. **Repair and Parts Manuals:** An *Operator's and Service manual* will be supplied with each new unit, except when units are duplicate orders and then only one of each is required. Manuals must be received prior to payment. Whenever available, the Owner prefers the manual in a CD format.

N. **Additional Information:** For information concerning the bid process, please contact the Purchasing Department at (970) 244-1533 or check the City of Grand Junction web page at www.gjcity.org. Copies of this bid document can be obtained online electronically on Bidnet at www.rockymountainbidsystem.com, from the Purchasing Division, **250 North 5th Street, Grand Junction, CO 81501, 970-244-1533**, or on the City of Grand Junction website, www.gjcity.org, click on “Bids”.

O. **Manufacturer’s Statement of Origin:** The new Unit shall be delivered with the Manufacturer’s Statement of Origin (MSO). Failure to provide MSO shall be grounds to refuse to accept vehicle.

P. **Title:** The awarded supplier shall provide Title work for the new vehicle within 10 days after the receipt of payment from the Owner.

For City Purchases, mail or deliver the Title to: Fleet Services, 333 West Avenue, Building C, Grand Junction, CO 81501. If a problem arises in obtaining the Title within the 10 day window contact Tim Barker in Fleet Services at (970)-244-1532, or via E-mail timba@gjcity.org. Name on title shall read “**City of Grand Jctn**”.

For County Purchases, mail or deliver the Title to: Fleet Management, 1000 South 9th, Grand Junction, CO 81501. If a problem arises in obtaining the Title within the 10 day window contact Scott Forsgren in Fleet Management at (970)-244-1820 or via E-mail scott.forsgren@mesacounty.us.

SECTION III. GENERAL TERMS AND CONDITIONS

A. **Submission of Bids:** *Each bid shall be submitted in electronic format only, and only through the Rocky Mountain E-Purchasing website (www.rockymountainbidsystem.com). This site offers both “free” and “paying” registration options that allow for full access of the Owner’s documents and for electronic submission of proposals. (Note: “free” registration may take up to 24 hours to process. Please Plan accordingly.) Please view our “Electronic Vendor Registration Guide” at <http://www.gjcity.org/BidOpenings.aspx> for details.* (Purchasing Representative does not have access or control of the vendor side of RMEPS. If website or other problems arise during response submission, vendor **MUST** contact RMEPS to resolve issue prior to the response deadline. **800-835-4603**).

No bids will be considered in which the specifications, provisions or conditions of the price proposal have been modified. Bids shall be received and acknowledged only so as to avoid disclosure of process. However, all bids shall be open for public inspection after the contract is awarded. Trade secrets and confidential information contained in the bid so identified by Bidder as such will be treated as confidential by the Owner to the extent allowable in the Open Records Act.

B. **Assignment/Contract not used as Collateral:** Neither party shall assign or otherwise transfer any of the rights or delegate any of the duties set forth in this contract without prior written consent of the other party. The bidder shall not use this contract, or any portion thereof, for collateral for any financial obligation.

C. **Audits/Access to Records:** The Owner and any of its representatives shall have access to any books, documents, papers and records of the bidder which are pertinent to this solicitation and prospective contract.

D. **Availability of Funds:** Any Owner Contract resulting from a submission of a bid shall be deemed executor only to the extent of appropriations available to each Owner Department for purchases of such articles and services. The Owner’s extended obligation on those contracts, which envision extended

funding through successive fiscal periods shall be contingent upon actual appropriations for the following fiscal year.

E. Award and Purchase: The Owner reserves the right to reject any or all bids, to waive any informalities or technical defects in bids, and unless otherwise specified by the Owner or by the bidder, to accept any items or group of items in the bid, as may be in the best interest of the Owner. No verbal explanations, clarifications, additions or instructions will be binding to either the Owner or the bidders, except those confirmed in writing.

A signed purchase order/contract furnished to the successful bidder results in a binding contract without further action by either party.

F. Questions: Any questions concerning this project shall be directed to: Nicholas C Jones at the City of Grand Junction, 250 North 5th Street, Grand Junction, Colorado 81501, (970)-244-1533, E-mail Nickj@gjcity.org, between the hours of 8:00 a.m. and 4:00 p.m., Monday through Friday, excluding Holidays. ALL QUESTIONS MUST BE SUBMITTED IN WRITING.

G. Legal Compliance: The bidder shall keep informed of all Federal, State and local laws; ordinances, regulations and all orders and decrees of bodies or tribunals having any jurisdiction or authority which may affect those engaged or employed on the work or affect the conduct of the work. The bidder shall observe and comply with all such laws, ordinances, regulations, orders and decrees. The bidder shall protect and indemnify the Owner and its representatives against any claim or liability arising from or based on the violation of any such law, ordinance, regulation, order or decree whether by the supplier, subcontractor, supplier or the supplier's employees or any others engaged by the supplier. The laws of the State of Colorado will govern as to the interpretation, validity and effect for any contract that is entered into as a result of this solicitation. Venue for any lawsuit will be in Mesa County, Colorado.

H. Force Majeure: Neither party shall be liable for failure to perform under this contract if such failure to perform arises out of causes beyond the control and without the fault or negligence of the non-performing party. Such causes may include, but are not limited to, acts of God or the public enemy, fires, floods, epidemics, quarantine restrictions, freight embargoes and unusually severe weather. This provision shall become effective only if the party failing to perform immediately notifies the other party of the extent and nature of the problem, limits delay in performance to that required by the event, and takes all reasonable steps to minimize delays. The provision shall not be effective unless the failure to perform is beyond the control and without the fault or negligence of the non-performing party.

I. Indemnification: The bidder shall release, indemnify and hold harmless the Owner, their officers, agents, employees, successors and assignees from any cause of action, or claims or demands arising out of the Bidder's performance under this contract.

J. Gratuities: The bidder certifies and agrees that no gratuities, kickbacks or contingency fees were paid in connection with this contract, nor were any fees, commissions, gifts or other considerations made contingent upon the award of this contract. If the bidder breaches or violates this warranty, the Owner may, at its discretion, terminate this contract without liability to the Owner.

K. Material Availability: Bidders must accept responsibility for verification of material availability, production schedules and other pertinent data prior to submission of bid and delivery time. It is the responsibility of the bidder to notify the Owner immediately if materials specified are discontinued, replaced or not available for an extended period of time.

L. OSHA Standards: All bidders agree and warrant that services performed in response to this invitation shall conform to the standards declared by the U.S. Department of Labor under the OCCUPATIONAL

Safety and Health Act of 1970 (OSHA). In the event the services do not conform to OSHA Standards, the Owner may require the services to be redone at no additional expense to the Owner.

M. Non-collusion: Neither the said Bidder nor any of its officers, partners, owners, agents, representatives, employees or parties in interest, has in any way colluded, conspired, connived or agreed, directly or indirectly with any other bidder, firm or person to submit a collusive or sham bid in connection with the contract for which the attached bid has been submitted or to refrain from bidding in connection with such contract, or has in any manner, directly or indirectly, sought by agreement or collusion or communication or conference with any other bidder, firm or person or fix the price or prices in the attached bid or of any other bidder, or to fix any overhead, profit or cost element of the bid price or the bid price of any other bidder, or to secure through any collusion, conspiracy, connivance or unlawful agreement and advantage against the Owner, or any person interested in the proposed contract.

The price or prices quoted in this bid are fair and proper and are not tainted by a collusion, conspiracy, connivance, or unlawful agreement on the part of the bidder or any of its agents, representatives, owners, employees, or parties in interest.

P. Public Disclosure Record: If the bidder has knowledge of their employee(s) or sub-contractors having an immediate family relationship with a Owner employee or elected official, the bidder must provide the Purchasing Representative with the name(s) of these individuals. These individuals are required to file an acceptable "Public Disclosure Record", a statement of financial interest, before conducting business with the Owner.

O. Preparation of Bids: Bidders are expected to examine any drawings, specifications, schedules and instructions included in the bid package. Failure to do so will be at the bidder's risk.

In case of error in the extension of prices in the bid proposal, the unit price will govern. Unit price shown must be net.

P. Tax Exemption: Direct purchases of materials by the Owner are exempt from Colorado State sales or use tax. The bidder certifies that no Federal, State, County or Municipal tax will be added to the price shown on the Proposal Price sheet. An Owner Tax Exemption Certificate will be supplied to the successful bidder upon request.

Q. Bids Binding – 60 Days: Unless otherwise specified all formal bids submitted shall be binding for sixty calendar days following the bid opening date unless bidders, at the request of the Owner, agree to an extension.

R. Multiple Bids: Bidders must determine for themselves which product to offer. If said bidder chooses to submit more than one bid, THE ALTERNATE BID must be clearly marked "**Alternate Bid.**" The Owner reserves the right to make award in the best interest of the Owner.

S. Brand Names or Equal: Whenever in this bid invitation any particular materials, process, mechanism, and/or equipment are indicated, described or specified by patent, proprietary, or brand name, or by name of manufacturer, such wording will be deemed to be used for the purpose of facilitating minimum acceptable requirements and will be deemed to be followed by the words, "or equal." At the Owner's discretion, after the bid opening proof satisfactory must be provided by Bidder to show that the alternative product/equipment/vehicle is in fact, equal to specification requirements.

The Owner reserves the right to determine products of equal value. Suppliers will not be allowed to make unauthorized substitutions after award is made.

T. Termination of Contract: If at any time during the performance of the contract awarded as a result of this bid, in the opinion of the Owner, the work is not progressing satisfactorily or within the terms of this contract, then at the discretion of the Owner and after written notice to the supplier, the Owner may terminate the contract or any part of it.

U. Modification or Withdrawal of Bids: A bid that is in the possession of the Purchasing Division may be altered by facsimile, telegram or letter bearing the signature of name of the legal agent for the bidder, provided it is received prior to the time and date of the opening. Alterations should not reveal the price but should indicate the addition, subtraction or other changes in the bid. A bid that is in the possession of the Purchasing Manager may be withdrawn by the bidder up to the time of the bid opening. Bids may not be withdrawn after the bid opening. Failure of the successful bidder to furnish the service awarded from this bid may eliminate the bidder from the active bidder's list.

V. Addenda and Interpretations: If it becomes necessary to revise any part of an Owner bid, a written addendum shall be posted to the [Rocky Mountain E-Purchasing website](#). The bidder shall be responsible for obtaining all solicitation documents. The Owner is not bound by any oral representations, clarifications, or changes made in the written specifications by Owner employees, unless such clarification or change is provided in written addendum from the Owner. Receipt of addenda shall be acknowledged by initialing the proposal price sheet in the designated place.

W. Cooperative Purchasing: Purchases as a result of this solicitation are primarily for the Owner. Other governmental entities may be extended the opportunity to utilize the resultant contract award with the agreement of the successful provider and the participating agencies. All participating entities will be required to abide by the specifications, terms, conditions and pricings established in this solicitation.

The quantities furnished in this bid document are for only the Owner. It does not include quantities for any other jurisdiction.

The Owner will be responsible only for the orders placed for our jurisdiction. Other participating entities will place their orders on their respective Purchase Orders through their Purchasing office or use their purchasing card for purchase/payment as authorized or agreed upon between the provider and the individual entity. The Owner accepts no liability for payment of orders placed by other participating jurisdictions that choose to piggy-back on our solicitation.

Orders placed by participating jurisdictions under the terms of this solicitation will indicate their specific delivery and invoicing instructions.

X. Award: All bids will be awarded to the lowest responsive and responsible bidder. The Owner reserves the right to determine the lowest responsive and responsible bidder.

The Owner may involve all or some of the following factors: price; conformity to specifications; financial capacity to perform the services and/or provide commodities; previous performance and reputation; location of required and necessary facilities and/or equipment; availability and proximity of repair parts and/or warranty work; similar experience; delivery promise; terms of payments; compatibility as required in the bid documents; other associated and necessary costs; other objective and accountable factors which are reasonable.

Y. Inspections: Inspection and acceptance of materials or supplies will be made after delivery. Final inspection shall be conclusive except as regard to latent defects, fraud, or such gross mistakes as amount to fraud. Final inspection and acceptance or rejection of material or supplies shall be accomplished as promptly as practical, but failure to inspect and accept or reject material or supplies shall not impose liability on the Owner for such supplies as are not in accordance with the specifications. All delivered materials shall be accepted subject to inspection and physical count.

SECTION IV. SPECIFICATION/COMPLIANCE FORM

MINIMUM SPECIFICATION FOR: One (1), New, Current Model Year, CNG Powered, 4x2 Tandem Axle, Rear Dual Wheel, Dump Truck with Salt Box and Snow Plow. Bids must be offered as a complete, turn-key unit. All specifications must be met or exceeded or may be considered non-responsive. Incomplete responses will not be considered. Bidder shall note any exceptions to the bid on the Comment section. Bidder shall list in a separate attachment details concerning the exception. This sheet shall be labeled “Exception(s) to Bid Conditions and Specifications”.

All equipment furnished under this contract shall be new, unused, and the latest model offered by the manufacturer’s current production (unless otherwise stated). Accessories not specifically mentioned herein, but necessary to furnish a complete unit ready for use shall also be included.

<u>Specification/Description</u>	<u>As Specified</u>	<u>Comments:</u> <u>(If not exactly as specified, explain any Deviation.)</u>
Cab & Chassis		
1. Engine: Minimum, 300 HP. Inline 6 cylinder, turbo charged CNG fueled.		
2. Fuel Tanks: CNG Powered, shall have capacity of 60DGE		
3. Grill: Stationary grill to provide front crankshaft access for hydraulic pump.		
4. Fuel Filters: Primary and secondary.		
5. Air Cleaners: Dry type with primary and secondary elements and pre-cleaner		
6. Lubrication: Full flow with spin on filter elements.		
7. Exhaust System: Muffler with 4: vertical stack and 90 degree elbow top of elbow to be 10” above cab shield, frame mounted.		
8. Cooling System: Heavy duty with permanent antifreeze protection 50/50 mix with condition filter.		
9. Transmission: Allison automatic		
10. Axle Ratio: Capable of 70 mph		
11. Steering: Power		
12. Electrical System: 12 Volt with two (2) group 31 batteries low maintenance batteries.		
13. Alternator: Minimum 85 amp.		
14. Windshield Wipers: Electric intermittent with wash.		
15. Gauges: Volt, tach, hour, coolant, oil, fuel, and dual air pressure with low air buzzer and flashing light to include brake pressure application gauge.		
16. Horn: Dual note electric and cab mounted air horn.		
17. Backup Alarm: Alarm to sound immediately when shifted into reverse. (NO DELAY)		
18. LED Strobe Light: One each amber light mounted on left & right side of cab (Mirror mounted preferred) Two additional amber strobe lights (oval 6 ½” x 2 ¼”) to be		

<u>Specification/Description</u>	<u>As Specified</u>	<u>Comments:</u> <u>(If not exactly as specified, explain any Deviation.)</u>
mounted on rear of frame flush with body, one on the left and right side near the tail lights. The lights shall meet all state and federal regulations.		
19. Brakes: Full air "S" cam type-rear actuators to be mounted forward of rear axle. All slack adjusters to be self-adjusting. Rear brakes to have spring-loaded air activated parking brake (All brake drums to be external of axle).		
20. Compressor: 12 c.f.m. with Bendix AD-9 air dryer or equivalent to include automatic wet tank heated moisture dispensing system.		
21. Front Axle: 20,000 lb. minimum with H.D. shocks		
22. Rear Axle(s): 46,000 lb. minimum with overload springs.		
23. Frame: Full double reinforced frame extended 18" on front and rear to accommodate front snowplow mount, crankshaft driven hydraulic pump and dump bed/ chip bar configurations.		
24. Cab: Custom with tinted glass.		
25. Steering Column: Tilt		
26. Seats: Driver seat to be Duraform air ride, low back with adjustable upper backrest. Passenger seat to be suspension type.		
27. Upholstery: Cloth, dark tan or brown.		
28. Seat Belts: Driver and passenger with shoulder strap.		
29. Air Conditioning: 134-A factory installed.		
30. Heater: Heavy-duty high output.		
31. Sun Visors: Driver and passenger side.		
32. Accessory switch panel: A minimum of six (6) accessory switches shall be provided for powering auxiliary lights and other accessories.		
33. Mirrors: Heated electric 4 way adjustable mirrors West Coast style, full view, driver and passenger door mounted.		
34. Radio: Standard AM-FM with speakers and antenna.		
35. Hood: Full front tilt with service doors.		
36. Grille: To be stationary.		
37. Tires and Wheels: Eleven (11) 315/80R22.5- tubeless radial tires. Highway on front. Traction on rear. One (1) traction tire and wheel for spare per unit. Spare must accompany truck when unit is delivered.		
38. Front Bumper: HD with Two- (2) frame mounted tow hooks.		

<u>Specification/Description</u>	<u>As Specified</u>	<u>Comments: (If not exactly as specified, explain any Deviation.)</u>
39. Fuel Tank: Driver side step mount minimum 50 gallon.		
40. Exterior Color: White		
41. Frame Color: Black		
42. Mud Flaps: Shall furnish and install 2 “quick type” or equal, removable mud flaps and mounting hardware as per Attachment B.		

DUMP BODY SPECIFICATIONS

Unit shall conform to the best practice known to the body trade design, quality of material and workmanship. The equipment furnished shall conform to all ANSI safety standards Z245.1.

<u>Specification/Description</u>	<u>As Specified</u>	<u>Comments: (If not exactly as specified, explain any Deviation.)</u>
43. Floor: One (1) piece 1/4” AR400 steel floor with 4” rolled radius 8” up sides and no exposed external cross seals. Understructure shall be fabricated “western” cross member less design with tubular long sills. Long sills shall be fabricated from 100,000 psi yield strength steel.		
44. Sides: 3/16” high tensile steel with a fold down step accessible from the ground and grab handle on front of each outside corner.		
45. Front: 3/16” high tensile steel.		
46. Tailgate: 3/16” high tensile steel asphalt style with three (3) sloped cross braces and fully boxed top rail. Gate is to extend a minimum of 8” higher than side rails. Gate to include spreader chains and air operated gate latch release, with lifting eye welded outside top center.		
47. Top Rail: Heavy side fully boxed with 2” sideboard pockets front and rear corners. Not to exceed 95” from ground.		
48. Bottom Rail: Heavy duty, fully boxed, tapered for dirt shedding.		
49. Cab Shield: 10-gauge steel customized to fit cab and exhaust stack. With maximum height of 128” measured from the ground		
50. Rear Hinge: Heavy duty with 2” full shaft bosses drilled for grease.		
51. Pintle Hitch: Rear Frame mounted 40,000-lb. Pintle mounted 25” center from ground level. See Attachment A drawing of chip bar and bed measurements for further reference.		
52. Trailer Brakes: Trailer Air brake piping and fittings with folding glad hands with dirt caps ran to rear of truck and electric brake controller and wiring in protective loom to the extreme rear of truck for electric trailer brakes		
53. Trailer Lighting: Run wiring in protective loom to rear of truck for trailer lighting with a standard 7 Pin RV trailer plug for lights and brake wiring.		

<u>Specification/Description</u>	<u>As Specified</u>	<u>Comments:</u> <u>(If not exactly as specified, explain any Deviation.)</u>
<p>54. Load Tarp System: Pull tarps Super shield Electric Arm System with Black Mesh Tarps and extendable arms so tarp system will extend beyond tailgate when laid down flat. In cab dash mounted Controls. (MUST BE MOUNTED ON TOP OF HEADACHE APRON CONTACT FLEET PRIOR TO INSTALLATION)</p>		
<p>55. Safety Prop: Heavy Duty</p>		
<p>56. Spreader Apron: Bed with asphalt style tail gate to be mounted in such manner that a bolt on apron is not required.</p>		
<p>57. Dump Body Paint: Match truck body.</p>		
<p>58. Dump Control: Dump Controls mounted next to driver's seat in reach for ease of operation, which still will allow use of all mirrors.</p>		
<p>59. Lights: Tail, turn, stop, backup marker and rear cluster lights. All wiring to be run in protective loom or conduit</p>		
<p>60. Hoist Cylinder: Double acting cylinder with scissors type hoist. Heil Model 1821PL Or Equivalent. (Three stage not acceptable)</p>		
<p>61. Hydraulic Pump, The hydraulic pump shall be a U.S. manufactured axial piston pressure and flow compensated load-sensing type. The pump shall be cast iron construction and rated to 4.67 cubic inches per revolution at maximum stroke which will deliver 19.2 GPM @ 1000 engine RPM. The pump shall have a 2" inch suction line and 3/4" case drain line plumbed directly back to the reservoir. The pump shall be rated for 4000 PSI maximum and 3500 PSI continuous. The pump shall have a severe duty, high pressure outboard Teflon shaft seal that protects the pump shaft bearing and seal from external contamination and salt spray. The pump shall have a 1 1/4" keyed drive shaft and SAE type C mounting flange. The pump shall be a Force America FASD34. Pump shall be equipped with companion flange mount to aid in removing drive shaft for belt changes.</p>		
<p>62. Reservoir/Valve Enclosure: The hydraulic reservoir will be of 35 gallons nominal capacity.</p> <ul style="list-style-type: none"> • The hydraulic reservoir will be constructed of 10-gauge steel and be internally baffled. • The valve enclosure lid will protect from both road and pressure washer spray. • For ease of removal by a single person, the valve enclosure lid shall weigh less than 22 lbs. • The valve enclosure lid shall be black high density polyethylene with stainless steel reinforcements. • The valve enclosure lid shall have molded integrated handle for ease of removal. • The valve enclosure lid shall be attached to the reservoir via (4) rubber straps that can be removed without the use of any tools. • Mounting bracket is to be designed and supplied by the reservoir supplier. 		

<u>Specification/Description</u>	<u>As Specified</u>	<u>Comments:</u> <u>(If not exactly as specified, explain any Deviation.)</u>
<ul style="list-style-type: none"> • Mounting system should allow for a 1” frame clearance for frame obstructions. • Shall be mounted in a manner as to not transmit any truck torsional loads thru the tank. • The enclosure will use a gasket-less passive technology. (No rubber seals, gaskets, or weather stripping.) • The enclosure lid will be removable within seconds by one person without the use of tools. • All valve fittings, hose ends, filter, filler breather, sending units and any electrical connections are to be protected by enclosure cover. • The reservoir supplier will provide all valve fittings (JIC connections) and plumb the return line from the valve to the filter. • The cover will protect from both road and pressure washer spray. • The use of bulkhead fittings is not permitted. • The directional control valve must be easily accessible from all (6) sides without the use of tools. • Hose exit and entrance must allow for components to be mounted adjacent to the enclosure. • A 2” full flow brass ball valve shall be plumbed at the suction port of the tank. • A low oil/high temp sending unit shall be mounted in the reservoir. <p>The valve/tank assembly shall be a Force America model “VT35G2 Valve/Tank Assembly</p>		
V-BOX CONTROL		
<p>63. V-Box Controller: Force America SSC6100 CAN Bus spreader control system and all necessary plumbing ran to rear of Truck. Controls for all valve functions and electronic spreader control will be integrated into a single, self-contained control center. The control center shall be a padded armrest style that is ergonomically designed. Control center shall be modular in design for ease of installation and service, and wiring and connectors shall be keyed and color-coded throughout. All components must be durable for long life and trouble free operation.</p> <p>The electronic controller shall be a fully proportional multi-stick controller to operate all cylinder functions. Multi-stick PWM driver electronics shall include as standard the capability to control at least 9 proportional outputs simultaneously. The control is available in a 3-stick or 4-stick configuration. Controls for spreader must be located on armrest at the operator’s fingertips. There shall also be four auxiliary rocker switches available with an additional fifth switch being the main power switch for the spreader control. The switches shall be located between the joysticks and spreader control interface and each shall be rated for 15 amps continuous current minimum. Console options shall be</p>		

<u>Specification/Description</u>	<u>As Specified</u>	<u>Comments:</u> <u>(If not exactly as specified, explain any Deviation.)</u>
<p>capable of supplying full rated power to switch outputs when all four auxiliary switches are at full 15 amp load.</p> <p>For ease of operation the multi-stick control shall include the following features: LED-backlit nomenclature for all joystick functions and a momentary push-button at the top of the hoist stick to provide hoist-interlock. The “Hoist” decal shall be illuminated amber while disabled, and change to green backlighting when the driver engages the hoist interlock button. The green “Hoist” LEDs shall remain illuminated while the hoist is under operation and shall time-out after a period of hoist inactivity that is selectable from 0 to 15 seconds.</p> <p>The plow, wing, scraper, or other joysticks shall have the option to include a momentary pushbutton for activation of remote spreader standby, remote spreader blast, or electric joystick interlock. The multi-stick communication hardware/software shall include 4 integral float options. The use of add-on float modules is unacceptable. For flexibility of use the integral float programming shall have the following standard features:</p> <ul style="list-style-type: none"> • (4) axis functional float on any or all of the outputs with selectable forward/back, right/left functionality • 32-way or 4-way functionality • Selectable (3) second float delay timer • Optional float enable switch inputs. • When float output for a given joystick function is active, the LED-backlit nomenclature shall blink ON/OFF to provide visual feedback to the operator that the float function is engaged. <p>To ensure longevity of performance all lighting to be solid-state LED technology. The use of incandescent lamps or EL backlighting is unacceptable.</p> <p>All function joysticks shall be of contact-less Hall-effect design and offer up to a 5-Million cycle life. The use of potentiometers is unacceptable. To increase safety of operation, joystick communication hardware/software shall include the following standard features:</p> <ul style="list-style-type: none"> • Input power monitor circuitry with power quality diagnostics, • Redundant dual-reference joystick signals for each joystick axis • Joystick input off-center checking on all axes and output shutdown on system power-up • Joystick out-of-range fault condition checking and output shutdown • True outputs off with joystick centered • LED-backlit nomenclature shall illuminate and flash RED when any error condition exists and an audible alarm shall sound. 		

<u>Specification/Description</u>	<u>As Specified</u>	<u>Comments:</u> <u>(If not exactly as specified, explain any Deviation.)</u>
<ul style="list-style-type: none"> • LED-backlit nomenclature shall blink ON/OFF with increasing frequency as the corresponding function is increased in speed to give the operator visual feedback of each joystick output. <p>Multi-stick control shall communicate all joystick data over the spreader control CAN bus. For ease of service and diagnostics the multi-stick control shall have the following easily accessible through the spreader control calibration menus:</p> <ul style="list-style-type: none"> • Unique MIN/MAX adjustments for each joystick function (forward, back, left and right) • On-screen output status indicator's for each PWM output • Audible and visible output error status indicators with flashing error codes for each joystick function <p>The multi-stick control joystick outputs shall be communicated over the spreader control CAN bus to the Valve Module. Spreader control outputs and joystick control outputs shall be operated on the same Valve Module, or multiple modules as necessary.</p> <p>The electronic spreader control shall be designed for precise, closed-loop control of granular and prewet liquid applications and operate on a CAN Bus protocol. The Central Processing Unit (CPU) shall have keyed and color coded connections to prevent incorrect installation. The CPU shall be mounted in the cab with visual access to diagnostic LED's. Mounting of the CPU unit outside of the cab is unacceptable. The unit shall have USB connectivity for file and data transfer, Ethernet connection, a J1939 communication port for connection to the vehicle bus, a second CAN bus communication port for spreader-only data use, a J1708 connection for a road and air temperature sensor, and a RS-232 connection for AVL communication. The CPU shall have on-board diagnostics, which provide real-time status of CAN bus communication, processor activity, and power status. The CPU shall have a built-in audible alarm for diagnostic purposes. The CPU operating system shall NOT be Windows-based.</p> <p>The spreader control interface shall have two, color-coded, continuous rotation encoders for granular and spinner control. These encoders shall have integrated push buttons for blast mode and stand-by. The controller shall have a third multifunction 4-way joystick that has an integrated rotary encoder and push button, that can be used for menu navigation, prewet liquid control, or an additional conveyor function. There shall be four, two-way soft keys included in the interface that are generically-labeled and user-configurable for different functions depending on the equipment needs. The controller shall also utilize iButton technology that is capable of using a Supervisor key to provide access to the calibration parameters without the access code. The entire</p>		

<u>Specification/Description</u>	<u>As Specified</u>	<u>Comments:</u> <u>(If not exactly as specified, explain any Deviation.)</u>
<p>operator interface shall be backlit and encased in flexible silicone material with wear-limiting coating applied to the base silicone material. The operator interface shall communicate on the spreader control system CAN bus.</p> <p>The spreader control display shall be a remotely-mounted, 7” diagonal color TFT LCD, with a low-profile 16:9 widescreen format and minimum of 800X480 pixel resolution. LCD shall have variable LED backlighting. CCFL backlighting is unacceptable. The display shall include a scratch-resistant polycarbonate lens with anti-glare coating. A power status LED shall be immediately visible on the front of the display and shall report display diagnostics including loss of CAN communication. Display unit shall have a built-in audible alarm. To avoid driver distraction, the display shall have no integrated dials or pushbuttons and shall not be touch screen. LCD shall communicate on the spreader control system CAN bus.</p> <p>The operator menus shall be color-coded to match the encoder knobs on the operator interface. The display shall be capable of displaying the following on-screen simultaneously: Granular material name, granular material set point and actual application rate including units of measure, prewet liquid name, prewet liquid set point and actual application rate including units of measure, spread width, road temperature, air temperature, material usage total, liquid usage total, vehicle speed, and current date and time. The operator shall have the option of selecting five data items to be displayed onscreen during operation. The display will also provide four warning light indicators for low oil level, body up, oil temp, and filter bypass. These warning lights are to be functional regardless of spreader operation or status.</p> <p>The display must provide visual indication that the spreader control is connected to a compatible AVL device, if equipped. The spreader control shall warn operator if communication with the AVL device fails at power-up.</p> <p>A proportional PWM driver and input module (Valve Module) shall be remotely-mounted inside the hydraulic valve enclosure for control of both spreader control and joystick control outputs. The entire Valve Module shall be of rugged design for the mobile environment, and must meet IP68 requirements for dust and water ingress. The Valve Module shall include a minimum of eight proportional PWM outputs with potted valve output connections. All outputs shall be protected against short-circuits. Outputs shall be current-compensated and have adjustable PWM frequency. There shall be a minimum of five switch-to-ground type inputs for monitoring hydraulic system inputs such as oil level, body up, Hi and Low filter bypass, and oil temperature warnings. A minimum of two switch-to-ground type pulse train inputs shall be included in the Valve Module for</p>		

<u>Specification/Description</u>	<u>As Specified</u>	<u>Comments:</u> <u>(If not exactly as specified, explain any Deviation.)</u>
<p>connection of feedback sensors such as auger feedback and prewet liquid flowmeter feedback. A keyed and color-coded connection shall be provided for CAN bus connection to the CPU module inside the cab. A second CAN bus connection must be provided for daisy-chaining of multiple Valve Modules within the valve enclosure. Diagnostic LED's shall be included for every input and output on the Valve Module, as well as a power status LED and CAN bus activity LED's. The Valve Module shall be potted. The Valve Module shall include a stainless steel legend plate with engraved text for easy cleaning and identification of Valve Module connections.</p> <p>The integrated spreader control and joystick control system shall be equipped with a qualified ESTOP device that immediately disconnects battery power from all outputs. All spreader control and joystick-operated outputs shall immediately cease to function and the system display shall inform the operator that the ESTOP device has been activated. The ESTOP device must remove power from all output devices, while maintaining power to the display and CPU for diagnostic purposes. Resetting of the ESTOP device shall not result in spreader control and joystick-operated outputs returning to an ON state without operator acknowledgement.</p> <p>Display to be dash mounted for easy visual reference when driving</p>		
<p>64. Plow Power Float</p> <p>The counterbalance valve shall take some of the plows weight off the blade and on to the front of the plow truck. The valve shall work by supplying pressure to the lift cylinder to partially lift the plow. The same valve works for both single acting and double acting plow lift cylinders. Unused ports are plugged.</p> <p>Electrical switching shall be provided to automatically turn the valve off in order to hold the plow in the raised position. If the counterbalance valve is not turned off the plow will drift down after it is raised. Float lift pressure will need to be adjusted to insure that the plow drifts down at the right speed. The valve shall use a pressure reducing/relieving valve to control the float lift pressure. Two solenoid valves wired together turn the valve off and on. One solenoid valve opens the inlet of the pressure reducing valve to the pump. The other solenoid valve opens the outlet of the pressure reducing/relieving valve to the lift port. Oil flowing in and out of the lift port is restricted with an orifice.</p>		
<p>65. Control Valve: The hydraulic valve shall be of modular manifold design. Each hydraulic function requires an individual manifold stacked together to form the manifold base. The manifold base shall consist of an inlet section with SAE #16 inlet porting, SAE #20 outlet porting, and SAE #4 load sense porting. There shall be a main system relief in the inlet section to protect the system from high pressure in case the pump compensators fail. The dump body manifold shall be stacked next to the inlet section, and capable of 40 GPM with</p>		

<u>Specification/Description</u>	<u>As Specified</u>	<u>Comments:</u> <u>(If not exactly as specified, explain any Deviation.)</u>
<p>SAE #12 porting. The hydraulic control valves shall be pulse-width modulated, proportionally controlled. Each hydraulic valve segment shall be individually mounted to the manifold base assembly and be serviceable without removing any hydraulic hoses or any other hydraulic valve segments. Each hydraulic valve segment shall have individual pressure compensation to achieve independent simultaneous operations. All segments shall have heavy-duty continuous duty coils and connections shall be with Din connectors. All coils shall operate at 12 VDC and require a maximum of 1400 mille-amps. Each segment shall be equipped with a manual override except for the auger and spinner sections. The dump body segment shall be rated to 40 GPM, with all other segments rated to 20 GPM. If a double acting hoist is utilized, the dump body segment shall be equipped with a down side relief to protect the body down function. This relief shall be set to the hoist manufacturer's specifications. Valve segments shall be Force America Add-A-Fold® model or prior approved equal. The valve is to be arranged as follows:</p> <p>Hoist: 4-way with 500 PSI down side work port relief valve Plow lift: 4-way with down side relief. Power float valve to save on cutting edge wear Plow angle: 4-way Spreader Functions: Spin-A-Veyer end cover section, consisting of two pressure compensated cartridges that are a single piece design with hardened cartridge bores and spools. These shall be operated independently via a 12 VDC pulse width modulated signal. Each valve shall have heavy duty 7/16-20 UNF screw style manual overrides that are adjustable from no flow to full flow. These valves shall be mounted in a housing that is made of aluminum with gray anodizing for corrosion resistance and durability. The auger/conveyor shall be a 14 GPM spool and the spinner shall be a 7 GPM spool.</p>		
<p>66. Snow Plow Mount with plow lights and plow blade: Snow plow mount type: UQH Power tilt with Force America float control assembly with power float valve and electrical installed that will provide plow lift up pressure and reduce weight on cutting edge.</p>		
V-Box Sander		
<p>67. General: This specification shall describe a v-box material spreader capable of hauling and spreading free flowing granular materials from a width of four (4) to forty (40) feet. This unit will consist of a steel body, discharge/feed conveyor, spinner disc, power drive, ladder to access top of spreader, free standing storage legs and all components necessary to make a complete operating unit. Bidders must submit with their bid complete specifications on the unit they propose to furnish. The manufacturing and production materials of the finest quality are to be used. This unit shall be factory ready to accept or retrofit servo controls.</p>		

<u>Specification/Description</u>	<u>As Specified</u>	<u>Comments:</u> <u>(If not exactly as specified, explain any Deviation.)</u>
<p>68. Body: This spreader shall be constructed of minimum 10 gauge steel with a double crimped top edge forming a 2” section for greater rigidity. The hopper body length shall not be less than 14’ feet with two feet of longitudinal overhung for supporting the spinner assembly. The hopper shall not be more than 84” outside width. The capacity of the hopper shall be 10 cubic yards water level full. There shall be a ladder attached to the rear of the spreader. The body sides shall have forty five degree pitch and shall incorporate attached side shields that prevent over flow material from entering the dump bed. The body longitudinals shall be manufactured of 10 gauge steel. The channel cross sills shall be 7 gauge steel. A 4” X 6” formed steel bolt in box beam will be elevated 3” above the top edge of the hopper, thus providing a longitudinal brace and hinge point for the top screens. A 7 gauge steel 12”X18” steel feed gate and ruler shall be provided at the rear of the hopper to allow for accurate discharge. The screw type jack with stainless steel crank shall be provided and be self-locking. There shall be 10 gauge formed side supports that extend the full angle height spaced on 2’ centers. All steel joints shall be welded. All sub-assemblies shall be secured with appropriate hardware. Tie downs: Shall be equipped with a tie-down kit as follows: Four manual ratchet winches(Kinedyne P/N 7820 or equal) That will be fully welded to outside of the instep 45-degree portion of the bottom rail of the dump body (2 per side, 1 front and 1 rear. Four (4) J” hooks (Kinedyne P/N1004 or equal) Shall be mounted to formed brackets constructed of non corrosive steel that are welded beneath the spill shield on all four corners of the spreader. These brackets will provide a minimum of 14” of adjustment travel for the J”hooks Four (4) minimum 4” nylon straps with a delta ring woven in one end. Shall provide a Kinedyne P/N 37030 or equal bar wrench to operate the winch Note The exact location of the winches and straps will be determined during the pre build meeting</p>		
<p>69. Conveyor: The conveyor system shall be of the bar flight type running longitudinally with the body feeding material to the feed gate opening. The overall conveyor width shall not be less than 24”. To protect the chain link strands, the top edge of the longitudinal shall be formed down over the strands exposing only the drag chain bar to the material. The conveyor floor shall be of the flat design and manufactured of 10 gauge steel. The conveyor floor shall be supported on 12 gauge steel cross angles spaced approximately 12” apart. The gearbox shall have hardened and ground bronze gears mounted on a 1 ½” diameter drive shaft and supported on tapered roller bearings. The gearbox ration shall be 50:1ratio with no exceptions. The drive and idler sprockets shall be 6 tooth drop forged steel sprockets keyed to the 1 ½” diameter drive shaft and 1 ¼” diameter idler shaft. Both the conveyor</p>		

<u>Specification/Description</u>	<u>As Specified</u>	<u>Comments:</u> <u>(If not exactly as specified, explain any Deviation.)</u>
shafts shall have heavy duty, dust sealed, self-aligning ball bearings equipped with grease fittings. A heavy duty spring loaded idler adjustment assembly shall provide approximately 4" of adjustment for proper conveyor chain tension		
70. Conveyor Chain: The conveyor chain shall be heat treated 2.25" pitch self-cleaning pintle type with 7/16" pins, and a tensile strength per strands of 21,000 pounds. This chain shall utilize 3/8" x 1 1/2" x 18 3/4" crossbars welded on both the top and the bottom to every other link making an overall width of 22".		
71. Spinner Assembly: The distributor disc shall be 20" polyurethane.		
72. Power Drive: The conveyor chain shall be driven through the 50:1 ratio worm drive gearbox by a low speed, high torque "orbital type" hydraulic motor. This motor shall be directly coupled to the spinner hub thus eliminating any extension shaft or bearings. The gear box or drive motor shall be equipped with all necessary components for spreader feedback system. /Feedback sensor built into pump motor preferred.		
73. Top Screens: The top screens shall be constructed of 3/8" steel rods welded to form a 2.5" square mesh, which is framed by a combination of 1/4" x 1 1/2" flat steel and 2" angle iron with the edge supports reinforced by 1/4" x 1" flat bars. Top screens shall be designed in a manner to be easily removed and installed similar in design like or similar to a "Drop and Lock" type hinge. Screens utilizing hardware that may vibrate loose are not acceptable		
74. Inverted Vee: The inverted vee shall be adjustable in height, and located approximately 8" to 10" above the conveyor. This inverted vee shall be made of 10 gauge steel		
75. Painting: All steel metal shall be orange powder coat painted. Carbon steel components shall be chemically cleaned and coated with a lead free rust inhibitive primer and painted lead free grey enamel.		
76. Light Kit: This assembly shall include one (3) light ID cluster, two 5" stop turn, and tail lights, two red clearance lights, one center mounted work light, junction box with 6' pigtail, and four red reflectors. All lights shall be shielded and mounted on the V-Box.		
77. Front Grease Extensions: Grease tube extension from front bearings to rear manifold.		
78. Tailgate Latch Kit: The tailgate latch will be used for additional support in securing the unit into the dump body. A box iron of 3" x 3"x 3/16" and of sufficient length to reach the tailgate latches will be furnished along with 1 1/4" x 10" shafting. Self-loading leg kit: Unit shall be equipped with an adjustable leg kit for ease of loading on truck as well as summer storage.		
SNOW PLOW		
79. 12 Foot snow plow blade. Equivalent to Monro MP36101-SC		

<u>Specification/Description</u>	<u>As Specified</u>	<u>Comments:</u> <u>(If not exactly as specified, explain any Deviation.)</u>
Moldboard Thickness: 10 Gauge No. of 1/2" Vertical Ribs: 6 Moldboard Top Angle: 2" x 3" x 3/8" Adjustable Moldboard Pitch Settings: 5°, 10°, 20° Semi-Circle: 3 1/2" x 3 1/2" x 1/2" A36 Hot Rolled Angle Bottom Moldboard Angle: 3/4" x 4" x 4" Reversing Cylinders: (2) 3" x 10" Double Acting Reversing Limits (left & right): 35° Plow to Table Hinge Points: 4 Cutting Edge: 5/8" x 8" Top Punched Pivot Pin: 1 1/4" Stopped Cylinder Pins: 1 1/4" Lift System: Built-In Level Lift Equipped with a 24" x 12' rubber deflector minimum 3/8" maximum 1/2" thick, fixed to top of moldboard with 5/16 bolts, a backing strip, lock washers and nuts		
80. Warranty: Full factory standard unlimited warranty (please specify warranty period for cab & chassis, engine & drive train and transmission, and V-Box)		
81. Prebuild Meeting: After receipt of chassis the winning body builder will contact the City to arrange for a pre build meeting where items such as switch and display location, and other build questions can be clarified. The meeting will take place at the body builder's location. Travel expense will be paid by the City user department.		
82. Pre delivery inspection: All components attachments and accessories shall be delivered together with the truck pretested for functionality. Each component shall be tested again by the Cities user department at time of delivery while a selling company representative is on site. Please allow time during the delivery process for this to be accomplished.		

SECTION V. BID FORM

The Owner will receive electronic bids through the Rocky Mountain E-Purchasing website, www.rockymountainbidsystem.com, prior to the date and time indicated on the front of this document at which time the bids will be publicly opened and read, for furnishing the materials, supplies, equipment and/or services, as shown below and/or attached hereto: **FOB DESTINATION** delivered at Grand Junction or Mesa County, Colorado. **TRANSPORTATION CHARGES PREPAID.** All in accordance with the bid conditions, special provisions, and specifications attached or as indicated below.

Purchasing Representative: Nicholas C Jones

Nickj@gjcity.org

970-244-1533

1) Net price for One (1), New, Current Model Year, CNG Powered, 4x2 Tandem Axle, Rear Dual Wheel, Dump Truck with Salt Box and Snow Plow:

\$ _____

Written: _____ Dollars

Year/Manufacture/Model No.:

MANUALS (Electronic Preferred), (Please indicate "Incl." if included in above pricing or "N/A" if not available.):

Wiring \$ _____ Emissions \$ _____ Workshop \$ _____ Parts \$ _____

DELIVERY: State expected delivery time after receipt of order. _____ days ARO

Order Cutoff Date (Please specify the order cutoff date if any): _____

WARRANTY: Specify Warranty and supply manufacturer's documentation:

CNG Price Increase: For information purposes only, please state the increase in price to the Owner, between the Diesel Equivalent Unit and the CNG Unit Proposed: \$ _____ /unit

2) Optional Equipment: Mid-Mount Wing Plow; please provide the additional price for the following specification: 10 Foot mid mount wing plow with trip edge, or trip moldboard and dual cylinder control for positioning installed and operational. Additional strobe light mounted on outside edge of top of moldboard for vehicle safety:

\$ _____

3) Trade-In Unit Options: The owner has one (1) unit that it would like to receive pricing for Trade-In (Pricing Stated Above Shall Not be Contingent of Trade-In Units. Trade in pricing will be deducted from the prices stated above at the time of Purchase Order Issuance.) (All engine hours are approximate):

Unit 2141 – 2002 Mack Granite CV713 with EM7-300 engine and Allison Transmission – 9500 Engine Hours. Included is Unit 873, 2008 Monroe MV-180-84-50-SF V-Box. No Snow Plow included. Trade-In Price:

\$ _____

Comments:

ADDENDA: State number of Addenda received: _____.

DATE _____

- In compliance with the above, and subject to all the conditions hereon, the undersigned offers and agrees to furnish items upon which prices are quoted, at the price(s) set forth if this bid is accepted within _____ days from the award.
- Direct purchases by the City of Grand Junction are tax exempt from Colorado Sales or Use Tax. Tax exempt #98-903544.
- Direct purchases by Mesa County are tax exempt from Colorado Sales or Use Tax. Tax exempt #98-04241.
- The undersigned certifies that no Federal, State, County or Municipal tax will be added to the above quoted prices.
- Prompt payment discount of _____ percent of the net dollar amount will be offered to the Owner if the invoice is paid within _____ days after the receipt of the invoice.
- The undersigned certifies and agrees that this bid is submitted in accordance with all applicable Federal, State, County, and City laws.

(Company Name of Bidder – Typed or Printed)

(Phone Number of Bidder)

(Address of Bidder)

(Authorized Dealer Agent – Typed or Printed)

(City, State, and Zip Code)

(Authorized Signature)

(E-mail Address of Agent or Sales Contact)

Attachment A -- IFB-4128-15-NJ

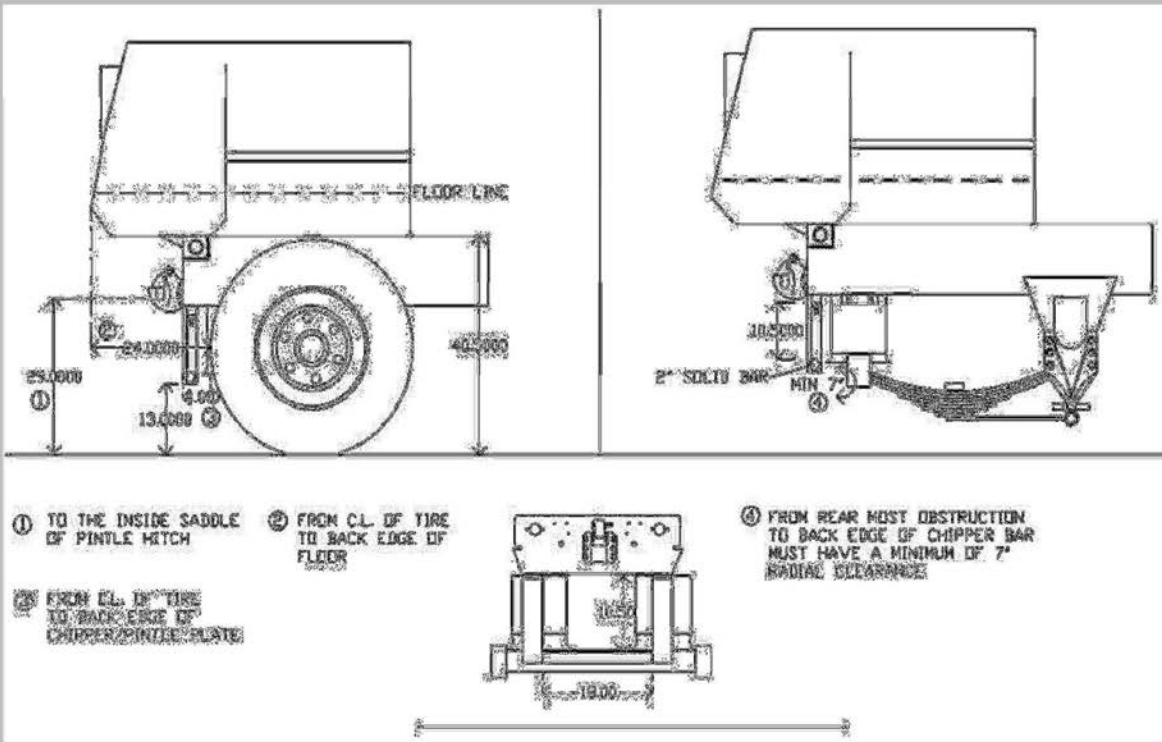

Attachment B – IFB-4128-15-NJ

