



Purchasing Division



Invitation for Bid

IFB-4213-16-DH

Deck Replacements for Crystal Brook Apartment Buildings for
Grand Junction Housing Authority

Responses Due:

April 13, 2016 prior to 3:30pm

Accepting Electronic Responses Only

**Responses Only Submitted Through the Rocky Mountain E-Purchasing
System (RMEPS)**

<https://www.rockymountainbidsystem.com/default.asp>

(Purchasing Representative does not have access or control of the vendor side of RMEPS. If website or other problems arise during response submission, vendor **MUST** contact RMEPS to resolve issue prior to the response deadline. 800-835-4603)

Purchasing Representative:

Duane Hoff Jr., Senior Buyer

duaneh@gjcity.org

970-244-1545

This document has been developed specifically to solicit competitive responses for this solicitation, and may not be the same as previous City of Grand Junction/Mesa County solicitations. All vendors are urged to thoroughly review this solicitation prior to responding. Submittal by **HARD COPY, FAX, OR E-MAIL IS NOT ACCEPTABLE** for this solicitation.

Invitation for Bids

Table of Contents

Section 1	Instruction to Bidders
Section 2	General Contract Conditions
Section 3	Statement of Work
Section 4	Contractor's Bid Form
	Price Proposal/Bid Schedule Form
	Attachments

1. Instructions to Bidders

- 1.1. **Purpose:** The City of Grand Junction, on behalf of the Grand Junction Housing Authority, is soliciting competitive bids from qualified and interested companies for all labor, equipment, and materials required to demolish and remove existing decking and provide and install new decking for buildings 1760 and 1761 located at the Crystal Brook Apartments. All dimensions and scope of work should be verified by Contractors prior to submission of bids.
- 1.2. **Mandatory Site Visit/Briefing:** **Prospective bidders are required to attend a site visit/briefing on April 5, 2016 at 10:00am.** Meeting location shall be at Crystal Brook Apartments, 1760 Laveta Street, Grand Junction, CO. The purpose of this visit will be to inspect and to clarify the contents of this Invitation for Bids (IFB).
- 1.3. **The Owner:** The Owner is the Grand Junction Housing Authority (GJHA), Colorado and is referred to throughout this Solicitation. The term Owner means the Owner or his authorized representative.
- 1.4. **Prequalification Requirement: CITY ONLY** Contractors submitting bids over \$50,000 must be pre-qualified in accordance with the City's "*Rules and Procedures for Pre-qualification of Contractors*". All bids received by the specified time will be opened, but the City will reject bids over \$50,000 from contractors who have not been prequalified. Application forms for prequalification are available at the Administration Office of the Department of Public Works and Planning, City Hall, 250 North Fifth Street, Room 245. Call 970-256-4126 or 970-244-1555 for additional information. Due to the time required to process applications, all applications must be submitted no later than two weeks prior to the Response Due Date. Application link: <http://www.gjcity.org/PreQualification.aspx>
- 1.5. **Submission:** **Each proposal shall be submitted in electronic format only, and only through the Rocky Mountain E-Purchasing website (<https://www.rockymountainbidsystem.com/default.asp>).** This site offers both "free" and "paying" registration options that allow for full access of the Owner's documents and for electronic submission of proposals. (Note: "free" registration may take up to 24 hours to process. Please Plan accordingly.) Please view our "Electronic Vendor Registration Guide" at <http://www.gjcity.org/BidOpenings.aspx> for details. (Purchasing Representative does not have access or control of the vendor side of RMEPS. If website or other problems arise during response submission, vendor **MUST** contact RMEPS to resolve issue prior to the response deadline. **800-835-4603**)
- 1.6. **Printed Form for Price Bid:** All Price Bids must be made upon the Contractor's Bid Form attached, and should give the amounts both in words and in figures, and must be signed and acknowledged by the bidder.
- 1.7. **Exclusions:** No oral, telephonic, emailed, or facsimile bid will be considered

- 1.8. **Contract Documents:** The complete IFB and bidder's response compose the Contract Documents. Copies of these documents can be obtained from the City Purchasing website, <http://www.gjcity.org/BidOpenings.aspx>.
- 1.9. **Examination of Specifications:** Bidders shall thoroughly examine and be familiar with the project Statement of Work. The failure or omission of any Offeror to receive or examine any form, addendum, or other document shall in no way relieve any Offeror from any obligation with respect to his bid. The submission of a bid shall be taken as evidence of compliance with this section.
- 1.10. **Questions Regarding Statement of Work:** Any information relative to interpretation of Scope of Work or specifications shall be requested of the Purchasing Representative, in writing, in ample time prior to the response time.
- 1.11. **Addenda & Interpretations:** If it becomes necessary to revise any part of this solicitation, a written addendum will be posted electronically on the City's website at <http://www.gjcity.org/BidOpenings.aspx>. The Owner is not bound by any oral representations, clarifications, or changes made in the written specifications by Owner, unless such clarification or change is provided in written addendum form from the City Purchasing Representative.
- 1.12. **Taxes:** The Owner is exempt from State retail and Federal tax. The bid price must be net, exclusive of taxes.
- 1.13. **Offers Binding 60 Days:** Unless otherwise specified, all formal offers submitted shall be binding for sixty (60) calendar days following opening date, unless the Bidder, upon request of the Purchasing Representative, agrees to an extension.
- 1.14. **Collusion Clause:** Each bidder by submitting a bid certifies that it is not party to any collusive action or any action that may be in violation of the Sherman Antitrust Act. Any and all bids shall be rejected if there is evidence or reason for believing that collusion exists among bidders. The Owner may, or may not, accept future bids for the same services or commodities from participants in such collusion.
- 1.15. **Public Disclosure Record:** If the bidder has knowledge of their employee(s) or sub-contractors having an immediate family relationship with a City/County employee or elected official, the bidder must provide the Purchasing Representative with the name(s) of these individuals. These individuals are required to file an acceptable "Public Disclosure Record", a statement of financial interest, before conducting business with the City/County.

2. General Contract Conditions for Construction Projects

- 2.1. **The Contract:** This Invitation for Bid, submitted documents, and any negotiations, when properly accepted by the City/County, shall constitute a contract equally binding between the City/County and Contractor. The contract represents the entire and integrated agreement between the parties hereto and supersedes all prior negotiations, representations, or agreements, either written or oral. The contract may be amended or modified with Change Orders, Field Orders, or Addendums.

- 2.2. The Work:** The term Work includes all labor necessary to produce the construction required by the Contract Documents, and all materials and equipment incorporated or to be incorporated in such construction.
- 2.3. Execution, Correlation, Intent, and Interpretations:** The Contract Documents shall be signed in not less than triplicate by the Owner (City/County) and Contractor. City/County will provide the contract. By executing the contract, the Contractor represents that he/she has visited the site, familiarized himself with the local conditions under which the Work is to be performed, and correlated his observations with the requirements of the Contract Documents. The Contract Documents are complementary, and what is required by any one, shall be as binding as if required by all. The intention of the documents is to include all labor, materials, equipment and other items necessary for the proper execution and completion of the scope of work as defined in the technical specifications and drawings contained herein. All drawings, specifications and copies furnished by the City/County are, and shall remain, City/County property. They are not to be used on any other project, and with the exception of one contract set for each party to the contract, are to be returned to the owner on request at the completion of the work.
- 2.4. The Owner:** The Owner is the City of Grand Junction and/or Mesa County, Colorado and is referred to throughout the Contract Documents. The term Owner means the Owner or his authorized representative. The Owner shall, at all times, have access to the work wherever it is in preparation and progress. The Contractor shall provide facilities for such access. The Owner will make periodic visits to the site to familiarize himself generally with the progress and quality of work and to determine, in general, if the work is proceeding in accordance with the contract documents. Based on such observations and the Contractor's Application for Payment, the Owner will determine the amounts owing to the Contractor and will issue Certificates for Payment in such amounts, as provided in the contract. The Owner will have authority to reject work which does not conform to the Contract documents. Whenever, in his reasonable opinion, he considers it necessary or advisable to insure the proper implementation of the intent of the Contract Documents, he will have authority to require the Contractor to stop the work or any portion, or to require special inspection or testing of the work, whether or not such work can be then be fabricated, installed, or completed. The Owner will not be responsible for the acts or omissions of the Contractor, and sub-Contractor, or any of their agents or employees, or any other persons performing any of the work.
- 2.5. Contractor:** The Contractor is the person or organization identified as such in the Agreement and is referred to throughout the Contract Documents. The term Contractor means the Contractor or his authorized representative. The Contractor shall carefully study and compare the General Contract Conditions of the Contract, Specification and Drawings, Scope of Work, Addenda and Modifications and shall at once report to the Owner any error, inconsistency or omission he may discover. Contractor shall not be liable to the Owner for any damage resulting from such errors, inconsistencies or omissions. The Contractor shall not commence work without clarifying Drawings, Specifications, or Interpretations.
- 2.6. Sub-Contractors:** A sub-contractor is a person or organization who has a direct contract with the Contractor to perform any of the work at the site. The term sub-contractor is referred to throughout the contract documents and means a sub-contractor or his authorized representative.

- 2.7. Award of Sub-Contractors & Other Contracts for Portions of the Work:** As soon as practicable after bids are received and prior to the award of the contract, the successful Contractor shall furnish to the Owner, in writing for acceptance, a list of the names of the sub-contractors or other persons or organizations proposed for such portions of the work as may be designated in the proposal requirements, or, if none is so designated, the names of the sub-contractors proposed for the principal portions of the work. Prior to the award of the contract, the Owner shall notify the successful Contractor in writing if, after due investigation, has reasonable objection to any person or organization on such list. If, prior to the award of the contract, the Owner has a reasonable and substantial objection to any person or organization on such list, and refuses in writing to accept such person or organization, the successful Contractor may, prior to the award, withdraw their proposal without forfeiture of proposal security. If the successful Contractor submits an acceptable substitute with an increase in the proposed price to cover the difference in cost occasioned by the substitution, the Owner may, at their discretion, accept the increased proposal or may disqualify the Contractor. If, after the award, the Owner refuses to accept any person or organization on such list, the Contractor shall submit an acceptable substitute and the contract sum shall be increased or decreased by the difference in cost occasioned by such substitution and an appropriate Change Order shall be issued. However, no increase in the contract sum shall be allowed for any such substitution unless the Contractor has acted promptly and responsively in submitting a name with respect thereto prior to the award.
- 2.8. Supervision and Construction Procedures:** The Contractor shall supervise and direct the work, using his best skill and attention. He shall be solely responsible for all construction means, methods, techniques, sequences and procedures and for coordinating all portions of the work under the contract.
- 2.9. Warranty:** The Contractor warrants to the Owner that all materials and equipment furnished under this contract will be new unless otherwise specified, and that all work will be of good quality, free from faults and defects and in conformance with the Contract Documents. All work not so conforming to these standards may be considered defective. If required by Owner, the Contractor shall furnish satisfactory evidence as to the kind and quality of materials and equipment. If within ten (10) days after written notice to the Contractor requesting such repairs or replacement, the Contractor should neglect to make or undertake with due diligence to the same, the City may make such repairs or replacements. All indirect and direct costs of such correction or removal or replacement shall be at the Contractor's expense. The Contractor will also bear the expenses of making good all work of others destroyed or damaged by the correction, removal or replacement of his defective work.
- 2.10. Permits, Fees, & Notices:** The Contractor shall secure and pay for all permits, governmental fees and licenses necessary for the proper execution and completion of the work. The Contractor shall give all notices and comply with all laws, ordinances, rules, regulations and orders of any public authority bearing on the performance of the work. If the Contractor observes that any of the Contract Documents are at variance in any respect, he shall promptly notify the Owner in writing, and any necessary changes shall be adjusted by approximate modification. If the Contractor performs any work knowing it to be contrary to such laws,

ordinances, rules and regulations, and without such notice to the Owner, he shall assume full responsibility and shall bear all costs attributable.

- 2.11. Responsibility for Those Performing the Work:** The Contractor shall be responsible to the Owner for the acts and omissions of all his employees and all sub-contractors, their agents and employees, and all other persons performing any of the work under a contract with the Contractor.
- 2.12. Use of the Site:** The Contractor shall confine operations at the site to areas permitted by law, ordinances, permits and the Contract Documents, and shall not unreasonably encumber the site with any materials or equipment.
- 2.13. Cleanup:** The Contractor at all times shall keep the premises free from accumulation of waste materials or rubbish caused by his operations. At the completion of work he shall remove all his waste materials and rubbish from and about the project, as well as all his tools, construction equipment, machinery and surplus materials.
- 2.14. Insurance Requirements:** The selected Bidder agrees to procure and maintain, at its own cost, policy(s) of insurance sufficient to insure against all liability, claims, demands, and other obligations assumed by the Bidder pursuant to this Section. Such insurance shall be in addition to any other insurance requirements imposed by this Contract or by law. The Bidder shall not be relieved of any liability, claims, demands, or other obligations assumed pursuant to this Section by reason of its failure to procure or maintain insurance in sufficient amounts, durations, or types. Bidder shall procure and maintain and, if applicable, shall cause any Subcontractor of the Bidder to procure and maintain insurance coverage listed below. Such coverage shall be procured and maintained with forms and insurers acceptable to the Owner. All coverage shall be continuously maintained to cover all liability, claims, demands, and other obligations assumed by the Bidder pursuant to this Section. In the case of any claims-made policy, the necessary retroactive dates and extended reporting periods shall be procured to maintain such continuous coverage. Minimum coverage limits shall be as indicated below unless specified otherwise in the Special Conditions:

(a) Worker Compensation insurance to cover obligations imposed by applicable laws for any employee engaged in the performance of work under this Contract, and Employers' Liability insurance with minimum limits of:

One Million Dollars (\$1,000,000) each accident,
One Million Dollars (\$1,000,000) disease - policy limit, and
One Million Dollars (\$1,000,000) disease - each employee

(b) General Liability insurance with minimum combined single limits of:

One Million Dollars (\$1,000,000) each occurrence and
One Million Dollars (\$1,000,000) per job aggregate.

The policy shall be applicable to all premises and operations. The policy shall include coverage for bodily injury, broad form property damage (including completed operations), personal injury (including coverage for contractual and

employee acts), blanket contractual, products, and completed operations. The policy shall include coverage for explosion, collapse, and underground hazards. The policy shall contain a severability of interests provision.

(c) Comprehensive Automobile Liability insurance with minimum combined single limits for bodily injury and property damage of not less than:

One Million Dollars (\$1,000,000) each occurrence and
One Million Dollars (\$1,000,000) aggregate

This policy shall provide coverage to protect the contractor against liability incurred as a result of the professional services performed as a result of responding to this Solicitation.

With respect to each of Bidder's owned, hired, or non-owned vehicles assigned to be used in performance of the Work. The policy shall contain a severability of interests provision. The policies required by paragraphs (b), and (c) above shall be endorsed to include the Grand Junction Housing Authority (GJHA), and the GJHA's officers and employees as additional insureds. Every policy required above shall be primary insurance, and any insurance carried by the Owner, its officers, or its employees, or carried by or provided through any insurance pool of the Owner, shall be excess and not contributory insurance to that provided by Bidder. No additional insured endorsement to any required policy shall contain any exclusion for bodily injury or property damage arising from completed operations. The Bidder shall be solely responsible for any deductible losses under any policy required above.

2.15. Indemnification: The Contractor shall defend, indemnify and save harmless the Owner, and all its officers, employees, insurers, and self-insurance pool, from and against all liability, suits, actions, or other claims of any character, name and description brought for or on account of any injuries or damages received or sustained by any person, persons, or property on account of any negligent act or fault of the Contractor, or of any Contractor's agent, employee, sub-contractor or supplier in the execution of, or performance under, any contract which may result from proposal award. Contractor shall pay any judgment with cost which may be obtained against the Owner growing out of such injury or damages.

2.16. Miscellaneous Conditions: Material Availability: Contractors must accept responsibility for verification of material availability, production schedules, and other pertinent data prior to submission of bid. It is the responsibility of the bidder to notify the Owner immediately if materials specified are discontinued, replaced, or not available for an extended period of time. OSHA Standards: All bidders agree and warrant that services performed in response to this invitation shall conform to the standards declared by the US Department of Labor under the Occupational Safety and Health Act of 1970 (OSHA). In the event the services do not conform to OSHA standards, the Owner may require the services to be redone at no additional expense to the Owner.

2.17. Time: The Contract Time is the period of time allotted in the Contract Documents for completion of the work. The date of commencement of the work is the date established in a Notice to Proceed. If there is no Notice to Proceed, it shall be the date of the Contract or such other date as may be established therein, or as

established as entered on the Bid Form. The Date of Substantial Completion of the work or designated portions thereof is the date certified by the Owner when construction is sufficiently complete, in accordance with the Contract Documents.

- 2.18. Progress & Completion:** The Contractor shall begin work on the date of commencement as defined in the Contract, and shall carry the work forward expeditiously with adequate forces and shall complete it within the contract time.
- 2.19. Payment & Completion:** The Contract Sum is stated in the Contract and is the total amount payable by the Owner to the Contractor for the performance of the work under the Contract Documents. Upon receipt of written notice that the work is ready for final inspection and acceptance and upon receipt of application for payment, the Owner's Project Manager will promptly make such inspection and, when he finds the work acceptable under the Contract Documents and the Contract fully performed, the Owner shall make payment in the manner provided in the Contract Documents.
- 2.20. Quantities of Work and Unit Price:** Materials or quantities stated as unit price items in the Bid are supplied only to give an indication of the general scope of the Work. The City does not expressly or by implication agree that the actual amount of Work or material will correspond therewith, and reserves the right after award to increase or decrease the quantity of any unit item of the Work without a change in the unit price. The City also reserves the right to make changes in the Work including the right to delete any bid item in its entirety or add additional bid items.
- 2.21. Bid Bond:** Each Bid shall as a guaranty of good faith on the part of the Bidder be accompanied by a Bid Guaranty consisting of: a certified or cashier's check drawn on an approved national bank or trust company in the state of Colorado, and made payable without condition to the City; or a **Bid Bond** written by an approved corporate surety in favor of the City. The amount of the Bid Guaranty shall not be less than 5% of the total Bid amount. Once a Bid is accepted and a Contract is awarded, the apparent successful bidder has ten calendar days to enter into a contract in the form prescribed and to furnish the bonds with a legally responsible and approved surety. Failure to do so will result in forfeiture of the Bid Guaranty to the City as Liquidated Damages.
- 2.22. Performance & Payment Bonds:** Contractor shall furnish a Performance and a Payment Bond, each in an amount at least equal to that specified for the contract amount as security for the faithful performance and payment of all Contractor's obligations under the Contract Documents. These bonds shall remain in effect for the duration of the Warranty Period (as specified in the Special Conditions). Contractor shall also furnish other bonds that may be required by the Special Conditions. All bonds shall be in the forms prescribed by the Contract Documents and be executed by such sureties as (1) are licensed to conduct business in the State of Colorado and (2) are named in the current list of "Companies Holding Certificates of Authority as Acceptable Sureties on Federal Bonds and as Acceptable Reinsuring Companies" as published in Circular 570 (amended) by the Audit Staff, Bureau of Accounts, U.S. Treasury Department. All bonds signed by an agent must be accompanied by a certified copy of the Authority Act. If the surety on any bond furnished by the Contractor is declared bankrupt, or becomes insolvent, or its rights to do business in Colorado are terminated, or it ceases to meet the requirements of clauses (1) and (2) of this section, Contractor shall within five (5)

days thereafter substitute another bond and surety, both of which shall be acceptable to the City.

- 2.23. Retention:** The Owner will deduct money from the partial payments in amounts considered necessary to protect the interest of the Owner and will retain this money until after completion of the entire contract. The amount to be retained from partial payments will be five (5) percent of the value of the completed work, and not greater than five (5) percent of the amount of the Contract. When the retainage has reached five (5) percent of the amount of the Contract no further retainage will be made and this amount will be retained until such time as final payment is made.
- 2.24. Liquidated Damages for Failure to Enter Into Contract: CITY ONLY** Should the Successful Bidder fail or refuse to enter into the Contract within ten Calendar Days from the issuance of the Notice of Award, the City shall be entitled to collect the amount of such Bidder's Bid Guaranty as Liquidated Damages, not as a penalty but in consideration of the mutual release by the City and the Successful Bidder of all claims arising from the City's issuance of the Notice of Award and the Successful Bidder's failure to enter into the Contract and the costs to award the Contract to any other Bidder, to readvertise, or otherwise dispose of the Work as the City may determine best serves its interest.
- 2.25. Liquidated Damages for Failure to Meet Project Completion Schedule: CITY ONLY** If the Contractor does not achieve Final Completion by the required date, whether by neglect, refusal or any other reason, the parties agree and stipulate that the Contractor shall pay liquidated damages to the City for each such day that final completion is late. As provided elsewhere, this provision does not apply for delays caused by the City. The date for Final Completion may be extended in writing by the Owner.

The Contractor agrees that as a part of the consideration for the City's awarding of this Contract liquidated damages in the daily amount of **\$350.00** is reasonable and necessary to pay for the actual damages resulting from such delay. The parties agree that the real costs and injury to the City for such delay include hard to quantify items such as: additional engineering, inspection and oversight by the City and its agents; additional contract administration; inability to apply the efforts of those employees to the other work of the City; perceived inefficiency of the City; citizens having to deal with the construction and the Work, rather than having the benefit of a completed Work, on time; inconvenience to the public; loss of reputation and community standing for the City during times when such things are very important and very difficult to maintain.

The Contractor must complete the Work and achieve final completion included under the Bid Schedule in the number of consecutive calendar days after the City gives is written Notice to Proceed. When the Contractor considers the entire Work ready for its intended use, Contractor shall certify in writing that the Work is substantially complete. In addition to the Work being substantially complete, Final Completion date is the date by which the Contractor shall have fully completed all clean-up, and all items that were identified by the City in the inspection for final completion. Unless otherwise stated in the Special Conditions, for purposes of this liquidated damages clause, the Work shall not be finished and the Contract time shall continue to accrue until the City gives its written Final Acceptance.

If the Contractor shall fail to pay said liquidated damages promptly upon demand thereof after having failed to achieve Final Completion on time, the City shall first look to any retainage or other funds from which to pay said liquidated damages; if retainage or other liquid funds are not available to pay said liquidated damages amounts, the Surety on the Contractor's Performance Bond and Payment Bond shall pay such liquidated damages. In addition, the City may withhold all, or any part of, such liquidated damages from any payment otherwise due the Contractor. Liquidated damages as provided do not include any sums to reimburse the City for extra costs which the City may become obligated to pay on other contracts which were delayed or extended because of the Contractor's failure to complete the Work within the Contract Time. Should the City incur additional costs because of delays or extensions to other contracts resulting from the Contractor's failure of timely performance, the Contractor agrees to pay these costs that the City incurs because of the Contractor's delay, and these payments are separate from and in addition to any liquidated damages.

The Contractor agrees that the City may use its own forces or hire other parties to obtain Substantial or Final Completion of the work if the time of completion has elapsed and the Contractor is not diligently pursuing completion. In addition to the Liquidated Damages provided for, the Contractor agrees to reimburse the City for all expenses thus incurred.

- 2.26. Contingency/Force Account:** Contingency/Force Account work will be authorized by the Owner's Project Manager and is defined as minor expenses to cover miscellaneous or unforeseen expenses related to the project. The expenses are not included in the Drawings, Specifications, or Scope of Work and are necessary to accomplish the scope of this contract. Contingency/Force Account Authorization will be directed by the Owner through an approved form. Contingency/Force Account funds are the property of the Owner and any Contingency/Force Account funds, not required for project completion, shall remain the property of the Owner. Contractor is not entitled to any Contingency/Force Account funds, that are not authorized by Owner or Owner's Project Manager.
- 2.27. Protection of Persons & Property:** The Contractor shall comply with all applicable laws, ordinances, rules, regulations and orders of any public authority having jurisdiction for the safety of persons or property or to protect them from damage, injury or loss. Contractor shall erect and maintain, as required by existing safeguards for safety and protection, and all reasonable precautions, including posting danger signs or other warnings against hazards promulgating safety regulations and notifying owners and users of adjacent utilities. When or where any direct or indirect damage or injury is done to public or private property by or on account of any act, omission, neglect, or misconduct by the Contractor in the execution of the work, or in consequence of the non-execution thereof by the Contractor, he shall restore, at his own expense, such property to a condition similar or equal to that existing before such damage or injury was done, by repairing, rebuilding, or otherwise restoring as may be directed, or it shall make good such damage or injury in an acceptable manner.
- 2.28. Changes in the Work:** The Owner, without invalidating the contract, may order changes in the work within the general scope of the contract consisting of additions, deletions or other revisions, the contract sum and the contract time being adjusted accordingly. All such changes in the work shall be authorized by Change Order

and shall be executed under the applicable conditions of the contract documents. A Change Order is a written order to the Contractor signed by the Owner issued after the execution of the contract, authorizing a change in the work or an adjustment in the contract sum or the contract time. The contract sum and the contract time may be changed only by Change Order.

- 2.29. Claims for Additional Cost or Time:** If the Contractor wishes to make a claim for an increase in the contract sum or an extension in the contract time, he shall give the Owner written notice thereof within a reasonable time after the occurrence of the event giving rise to such claim. This notice shall be given by the Contractor before proceeding to execute the work, except in an emergency endangering life or property in which case the Contractor shall precede in accordance with the regulations on safety. No such claim shall be valid unless so made. Any change in the contract sum or contract time resulting from such claim shall be authorized by Change Order.
- 2.30. Minor Changes in the Work:** The Owner shall have authority to order minor changes in the work not involving an adjustment in the contract sum or an extension of the contract time and not inconsistent with the intent of the contract documents.
- 2.31. Field Orders:** The Owner may issue written Field Orders which interpret the Contract Documents in accordance with the specifications, or which order minor changes in the work in accordance with the agreement, without change in the contract sum or time. The Contractor shall carry out such Field Orders promptly.
- 2.32. Uncovering & Correction of Work:** The Contractor shall promptly correct all work rejected by the Owner as defective or as failing to conform to the contract documents whether observed before or after substantial completion and whether or not fabricated installed or competed. The Contractor shall bear all costs of correcting such rejected work, including the cost of the Owner's additional services thereby made necessary. If within one (1) year after the date of completion or within such longer period of time as may be prescribed by law or by the terms of any applicable special guarantee required by the contract documents, any of the work found to be defective or not in accordance with the contract documents, the Contractor shall correct it promptly after receipt of a written notice from the Owner to do so unless the Owner has previously given the Contractor a written acceptance of such condition. The Owner shall give such notice promptly after discover of condition. All such defective or non-conforming work under the above paragraphs shall be removed from the site where necessary and the work shall be corrected to comply with the contract documents without cost to the Owner. The Contractor shall bear the cost of making good all work of separate Contractors destroyed or damaged by such removal or correction. If the Owner prefers to accept defective or non-conforming work, he may do so instead of requiring its removal and correction, in which case a Change Order will be issued to reflect an appropriate reduction in the payment or contract sum, or, if the amount is determined after final payment, it shall be paid by the Contractor.
- 2.30. Amendment:** No oral statement of any person shall modify or otherwise change, or affect the terms, conditions or specifications stated in the resulting contract. All amendments to the contract shall be made in writing by the Owner.

- 2.31. Assignment:** The Contractor shall not sell, assign, transfer or convey any contract resulting from this IFB, in whole or in part, without the prior written approval from the Owner.
- 2.32. Compliance with Laws:** Bids must comply with all Federal, State, County and local laws governing or covering this type of service and the fulfillment of all ADA (Americans with Disabilities Act) requirements.
- 2.33. Confidentiality:** All information disclosed by the Owner to the Contractor for the purpose of the work to be done or information that comes to the attention of the Contractor during the course of performing such work is to be kept strictly confidential.
- 2.34. Conflict of Interest:** No public official and/or City/County employee shall have interest in any contract resulting from this IFB.
- 2.35. Contract Termination:** This contract shall remain in effect until any of the following occurs: (1) contract expires; (2) completion of services; (3) acceptance of services or, (4) for convenience terminated by either party with a written *Notice of Cancellation* stating therein the reasons for such cancellation and the effective date of cancellation.
- 2.36. Employment Discrimination:** During the performance of any services per agreement with the Owner, the Contractor, by submitting a Bid, agrees to the following conditions:
- 2.36.1.** The Contractor shall not discriminate against any employee or applicant for employment because of race, religion, color, sex, age, handicap, or national origin except when such condition is a legitimate occupational qualification reasonably necessary for the normal operations of the Contractor. The Contractor agrees to post in conspicuous places, visible to employees and applicants for employment, notices setting forth the provisions of this nondiscrimination clause.
- 2.36.2.** The Contractor, in all solicitations or advertisements for employees placed by or on behalf of the Contractor, shall state that such Contractor is an Equal Opportunity Employer.
- 2.36.3.** Notices, advertisements, and solicitations placed in accordance with federal law, rule, or regulation shall be deemed sufficient for the purpose of meeting the requirements of this section.
- 2.37. Immigration Reform and Control Act of 1986 and Immigration Compliance:** The Offeror certifies that it does not and will not during the performance of the contract employ illegal alien workers or otherwise violate the provisions of the Federal Immigration Reform and Control Act of 1986 and/or the immigration compliance requirements of State of Colorado C.R.S. § 8-17.5-101, *et.seq.* (House Bill 06-1343).
- 2.38. Ethics:** The Contractor shall not accept or offer gifts or anything of value nor enter into any business arrangement with any employee, official, or agent of the Owner.

- 2.39. Failure to Deliver:** In the event of failure of the Contractor to deliver services in accordance with the contract terms and conditions, the Owner, after due oral or written notice, may procure the services from other sources and hold the Contractor responsible for any costs resulting in additional purchase and administrative services. This remedy shall be in addition to any other remedies that the Owner may have.
- 2.40. Failure to Enforce:** Failure by the Owner at any time to enforce the provisions of the contract shall not be construed as a waiver of any such provisions. Such failure to enforce shall not affect the validity of the contract or any part thereof or the right of the Owner to enforce any provision at any time in accordance with its terms.
- 2.41. Force Majeure:** The Contractor shall not be held responsible for failure to perform the duties and responsibilities imposed by the contract due to legal strikes, fires, riots, rebellions, and acts of God beyond the control of the Contractor, unless otherwise specified in the contract.
- 2.42. Independent Contractor:** The Contractor shall be legally considered an Independent Contractor and neither the Contractor nor its employees shall, under any circumstances, be considered servants or agents of the Owner. The Owner shall be at no time legally responsible for any negligence or other wrongdoing by the Contractor, its servants, or agents. The Owner shall not withhold from the contract payments to the Contractor any federal or state unemployment taxes, federal or state income taxes, Social Security Tax or any other amounts for benefits to the Contractor. Further, the Owner shall not provide to the Contractor any insurance coverage or other benefits, including Workers' Compensation, normally provided by the Owner for its employees.
- 2.43. Nonconforming Terms and Conditions:** A bid that includes terms and conditions that do not conform to the terms and conditions of this Invitation for Bid is subject to rejection as non-responsive. The Owner reserves the right to permit the Contractor to withdraw nonconforming terms and conditions from its bid prior to a determination by the Owner of non-responsiveness based on the submission of nonconforming terms and conditions.
- 2.44. Ownership:** All plans, prints, designs, concepts, etc., shall become the property of the Owner.
- 2.45. Oral Statements:** No oral statement of any person shall modify or otherwise affect the terms, conditions, or specifications stated in this document and/or resulting agreement. All modifications to this request and any agreement must be made in writing by the Owner.
- 2.46. Patents/Copyrights:** The Contractor agrees to protect the Owner from any claims involving infringements of patents and/or copyrights. In no event shall the Owner be liable to the Contractor for any/all suits arising on the grounds of patent(s)/copyright(s) infringement. Patent/copyright infringement shall null and void any agreement resulting from response to this IFB.
- 2.47. Remedies:** The Contractor and Owner agree that both parties have all rights, duties, and remedies available as stated in the Uniform Commercial Code.

- 2.48. Venue:** Any agreement as a result of responding to this IFB shall be deemed to have been made in, and shall be construed and interpreted in accordance with, the laws of the City of Grand Junction, Mesa County, Colorado.
- 2.49. Expenses:** Expenses incurred in preparation, submission and presentation of this IFB are the responsibility of the company and cannot be charged to the Owner.
- 2.50. Sovereign Immunity:** The Owner specifically reserves its right to sovereign immunity pursuant to Colorado State Law as a defense to any action arising in conjunction to this agreement.
- 2.51. Non-Appropriation of Funds:** The contractual obligation of the Owner under this contract is contingent upon the availability of appropriated funds from this fiscal year budget as approved by the City Council or Board of County Commissioners from this fiscal year only. State of Colorado Statutes prohibit obligation of public funds beyond the fiscal year for which the budget was approved. Anticipated expenditures/obligations beyond the end of the current Owner's fiscal year budget shall be subject to budget approval. Any contract will be subject to and must contain a governmental non-appropriation of funds clause.
- 2.52. Cooperative Purchasing:** Purchases as a result of this solicitation are primarily for the City/County. Other governmental entities may be extended the opportunity to utilize the resultant contract award with the agreement of the successful provider and the participating agencies. All participating entities will be required to abide by the specifications, terms, conditions and pricings established in this Bid. The quantities furnished in this bid document are for only the City/County. It does not include quantities for any other jurisdiction. The City or County will be responsible only for the award for its jurisdiction. Other participating entities will place their own awards on their respective Purchase Orders through their purchasing office or use their purchasing card for purchase/payment as authorized or agreed upon between the provider and the individual entity. The City/County accepts no liability for payment of orders placed by other participating jurisdictions that choose to piggy-back on our solicitation. Orders placed by participating jurisdictions under the terms of this solicitation will indicate their specific delivery and invoicing instructions.
- 2.53. Keep Jobs in Colorado Act:** Contractor shall be responsible for ensuring compliance with Article 17 of Title 8, Colorado Revised Statutes requiring 80% Colorado labor to be employed on public works. Contractor shall, upon reasonable notice provided by the Owner, permit the Owner to inspect documentation of identification and residency required by C.R.S. §8-17-101(2)(a). If Contractor claims it is entitled to a waiver pursuant to C.R.S. §8-17-101(1), Contractor shall state that there is insufficient Colorado labor to perform the work such that compliance with Article 17 would create an undue burden that would substantially prevent a project from proceeding to completion, and shall include evidence demonstrating the insufficiency and undue burden in its response.

Unless expressly granted a waiver by the Owner pursuant to C.R.S. §8-17-101(1), Contractor shall be responsible for ensuring compliance with Article 17 of Title 8, Colorado Revised Statutes requiring 80% Colorado labor to be employed on public works. Contractor shall, upon reasonable notice provided by the Owner, permit the Owner to inspect documentation of identification and residency required by C.R.S. §8-17-101(2)(a).

2.53.1. "Public project" is defined as:

- (a) any construction, alteration, repair, demolition, or improvement of any land, building, structure, facility, road, highway, bridge, or other public improvement suitable for and intended for use in the promotion of the public health, welfare, or safety and any maintenance programs for the upkeep of such projects
- (b) for which appropriate or expenditure of moneys may be reasonably expected to be \$500,000.00 or more in the aggregate for any fiscal year
- (c) except any project that receives federal moneys.

3. Statement of Work

3.1. General: The City of Grand Junction, on behalf of the Grand Junction Housing Authority, is soliciting competitive bids from qualified and interested companies for all labor, equipment, and materials required to demolish and remove existing decking and provide and install new decking for buildings 1760 and 1761 located at the Crystal Brook Apartments. All dimensions and scope of work should be verified by Contractors prior to submission of bids.

3.2. Special Conditions & Provisions:

3.2.1 Pricing: Pricing shall be all inclusive to include but not be limited to: all labor, equipment, supplies, materials, freight (F.O.B. Destination – Freight Pre-paid and Allowed to each site), travel, mobilization costs, fuel, set-up and take down costs, and full-time inspection costs, and all other costs related to the successful completion of the project.

The Owner shall not pay nor be liable for any other additional costs including but not limited to: taxes, shipping charges, insurance, interest, penalties, termination payments, attorney fees, liquidated damages, etc.

3.2.2 Contractor must meet all federal, state, and local rules, regulations, and requirements for providing such services.

3.2.3 Licenses and Permits: Contractor is responsible for obtaining all necessary licenses and permits required for Construction, at Contractors expense. See Section 2.10. Contractor shall supply to Owner all copies of finalized permits.

3.2.4 Contractor Staging Area: Awarded Contractor shall coordinate with Owner for proposed project staging area (if required).

3.2.5 Freight/Shipping: All freight/shipping shall be F.O.B. Destination – Freight Pre-Paid and Allowed to Crystal Brook Apartments, 1975 Barcelona Way, Grand Junction, CO 81503.

3.2.6 Equipment/Product/Materials Quantities: Contractor shall be responsible for determining all measurements for correctness, and all quantities of equipment/products/materials required for successful project completion.

3.2.7 Working Schedule: Seven days per week from 7:30am-sunset. Any additional work schedule changes shall be coordinated with the Owner's Project Manager.

3.2.8 Term of Contract: Work shall begin no later than May 1, 2016, with final completion no later than 45 calendar days from the start date.

3.2.9 Estimated Quantities: Quantities listed in the solicitation documents are estimates only, and it is the responsibility of the Contractor to verify all quantities, units, measurements, etc., required to successfully complete the project to the standards of the solicitation documents.

3.2.10 Minimum Unit Quantities/Facilities/Apartments for Services: The bidder shall not establish minimum unit quantities/facilities/apartments under contract.

3.2.11 Contract: A binding contract shall consist of: (1) the IFB and any amendments thereto, (2) the bidder's response (bid) to the IFB, (3) clarification of the bid, if any, and (4) the City's Purchasing Department's acceptance of the bid by "Notice of Award" or by "Contract". All Exhibits and Attachments included in the IFB shall be incorporated into the contract by reference.

A. The contract expresses the complete agreement of the parties and, performance shall be governed solely by the specifications/scope of services and requirements contained therein.

B. Any change to the contract, whether by modification and/or supplementation, must be accomplished by a formal contract amendment signed and approved by and between the duly authorized representative of the bidder and the City Purchasing Division prior to the effective date of such modification. The bidder expressly and explicitly understands and agrees that no other method and/or no other document, including acts and oral communications by or from any person, shall be used or construed as an amendment or modification to the contract.

3.2.12 Mandatory Site Visit/Briefing: Prospective bidders are required to attend a site visit/briefing on April 5, 2016 at 10:00am. Meeting location shall be at Crystal Brook Apartments, 1760 Laveta Street, Grand Junction, CO. The purpose of this visit will be to inspect and to clarify the contents of this Invitation for Bids (IFB).

3.3. Scope of Work:

General/Safety: Remove all demolition debris to an onsite construction waste container on a daily basis. Construction waste container is to be provided by contractor. Prior to demobilizing from the project each day during the course of the work, utilize a magnetic device to scour the work area and collect any nails or other metallic debris from the ground that may create a hazard to pedestrians. Contain the work area during the entire course of construction by erecting fencing to create a safety zone to prevent pedestrian travel into the work from the surrounding landscape areas, and place temporary barriers over the exterior doors leading from the tenant units onto the decks to block access to the work area from the dwellings.

Implement an OSHA compliant safety program to ensure the safety of tenants residing in affected units, as well as the general public.

Demolition: Remove the existing wood deck structure and composite decking. The existing concrete support piers are to remain in place to receive new treated wood structure. There are (2) storage closets which are supported on the existing decking at each building which will remain and will need to be temporarily shored and supported during demolition of the existing deck structure.

Deck Construction: Install new decks per plan number S1 by Lindauer-Dunn dated 7/17/2015 which specifies a pressure treated wood structure with composite decking. Provide pricing as specified and provide alternate pricing for Redwood decking for Owner consideration.

Protection of Existing Surfaces: Protect all existing surfaces so as to remain free from damage through the course of construction. This includes but is not limited to gutters, downspouts, flashings, roof jacks, drip edge, windows & doors, trees, shrubs, landscape beds, sod areas, irrigation systems, and building siding. Take precautions not to drive on natural areas so as to rut sod areas or damage landscaping. Use tarps or other protection methods to avoid loose nails or demolition particles to become embedded in the landscape areas surrounding work. Immediately remove any debris that falls on landscape areas surrounding work or areas associated with the removal of debris. Immediately repair at contractor's expense and to the owner's satisfaction any areas damaged as a result of contractor's activities. Immediately protect any areas which are vulnerable to moisture penetration from damage and mold by the use of tarps or other means to prevent moisture penetration into walls, floors, or dwelling units. Maintain all required temporary protection systems through the duration of the project to prevent moisture intrusion into the building envelope until such time as the permanent structures are complete.

Execution: Complete the scope of work outlined above in no more than 45 calendar days. Working hours are from 7:30 AM to sunset, 7 days a week. Start work once notice to proceed is received, but no later than May 1, 2016. Provide all labor, equipment, tools, and materials to complete the project

Permitting / Approvals: Procure all required Local, State, and Federal permits as required by the authority having jurisdiction. Coordinate and comply with the City of Grand Junction Fire Marshall on the requirements concerning closure of the rear egress doors leading to the decks during demolition and construction of the new decks. Develop and provide to the Owner a written copy of a closure plan indicating approval by the GJHA Fire Marshall.

Waste Removal: Dispose of all waste and debris generated through the course of construction at Contractor's expense at an approved location.

Warranties: Provide a 1 year workmanship warranty against installation defects on the complete scope as set forth above. Install all materials per manufacturers recommended procedures and specifications so as to maintain product warranties. Provide necessary documentation to Owner required to invoke product warranties.

For Contractor's reference, see attached Deck Layout Drawing, and Structural Design Drawing.

3.4. IFB Tentative Time Schedule:

Invitation For Bids available	March 23, 2016
Mandatory Site Visit/Briefing	April 5, 2016
Inquiry deadline, no questions after this date	April 7, 2016
Addendum Posted	April 8, 2016
Submittal deadline for proposals	April 13, 2016
Contract execution (unless GJHA Board approval required)	April 15, 2016
Bonding & Insurance Cert due	April 25, 2016
Work begins no later than	May 1, 2016
Final Completion	45 Calendar Days from start date

3.5. Questions Regarding Scope of Services:

Duane Hoff Jr., Senior Buyer
City of Grand Junction
duaneh@gjcity.org

4. Contractor's Bid Form

Bid Date: _____

Project: IFB-4213-16-DH "Deck Replacements for Crystal Brook Apartment Buildings for Grand Junction Housing Authority"

Bidding Company: _____

Name of Authorized Agent: _____

Email _____

Telephone _____ **Address** _____

City _____ **State** _____ **Zip** _____

The undersigned Bidder, in compliance with the Invitation for Bids, having examined the Instruction to Bidders, General Contract Conditions, Statement of Work, Specifications, and any and all Addenda thereto, having investigated the location of, and conditions affecting the proposed work, hereby proposes to furnish all labor, materials and supplies, and to perform all work for the Project in accordance with Contract Documents, within the time set forth and at the prices stated below. These prices are to cover all expenses incurred in performing the work required under the Contract Documents, of which this Contractor's Bid Form is a part.

The undersigned Contractor does hereby declare and stipulate that this offer is made in good faith without collusion or connection to any person(s) providing an offer for the same work, and that it is made in pursuance of, and subject to, all terms and conditions of the Instructions to Bidders, the Specifications, and all other Solicitation Documents, all of which have been examined by the undersigned.

The Contractor also agrees that if awarded the Contract, to provide insurance certificates within ten (10) working days of the date of Notification of Award. Submittal of this offer will be taken by the Owner as a binding covenant that the Contractor will be prepared to complete the project in its entirety.

The Owner reserves the right to make the award on the basis of the offer deemed most favorable, to waive any formalities or technicalities and to reject any or all offers. It is further agreed that this offer may not be withdrawn for a period of sixty (60) calendar days after closing time. Submission of clarifications and revised offers automatically establish a new thirty day (30) period.

RECEIPT OF ADDENDA: the undersigned Contractor acknowledges receipt of Addenda to the Solicitation, Specifications, and other Contract Documents.

State number of Addenda received: _____.

It is the responsibility of the Bidder to ensure all Addenda have been received and acknowledged.

PRICE BID SCHEDULE: IFB-4213-16-DH Deck Replacements for Crystal Brook Apartment Buildings for Grand Junction Housing Authority

Item	Description	Total Price
1.	All labor, equipment, supplies, materials, freight (F.O.B. Destination – Freight Pre-paid and Allowed to each site), travel, mobilization costs, fuel, set-up and take down costs, and full-time inspection costs, and all other costs related to the successful completion of the project for decking replacements, as per the solicitation documents.	

Total Bid Price Written:

Add/Alternate Pricing for Redwood Decking

Item	Description	Total Price
2.	All labor, equipment, supplies, materials, freight (F.O.B. Destination – Freight Pre-paid and Allowed to each site), travel, mobilization costs, fuel, set-up and take down costs, and full-time inspection costs, and all other costs related to the successful completion of the project for decking replacements with Redwood decking, as per the solicitation documents.	

Total Bid Price Written:

By signing below, the Undersigned agree to comply with all terms and conditions contained herein.

Company: _____

Authorized Signature: _____

Title: _____

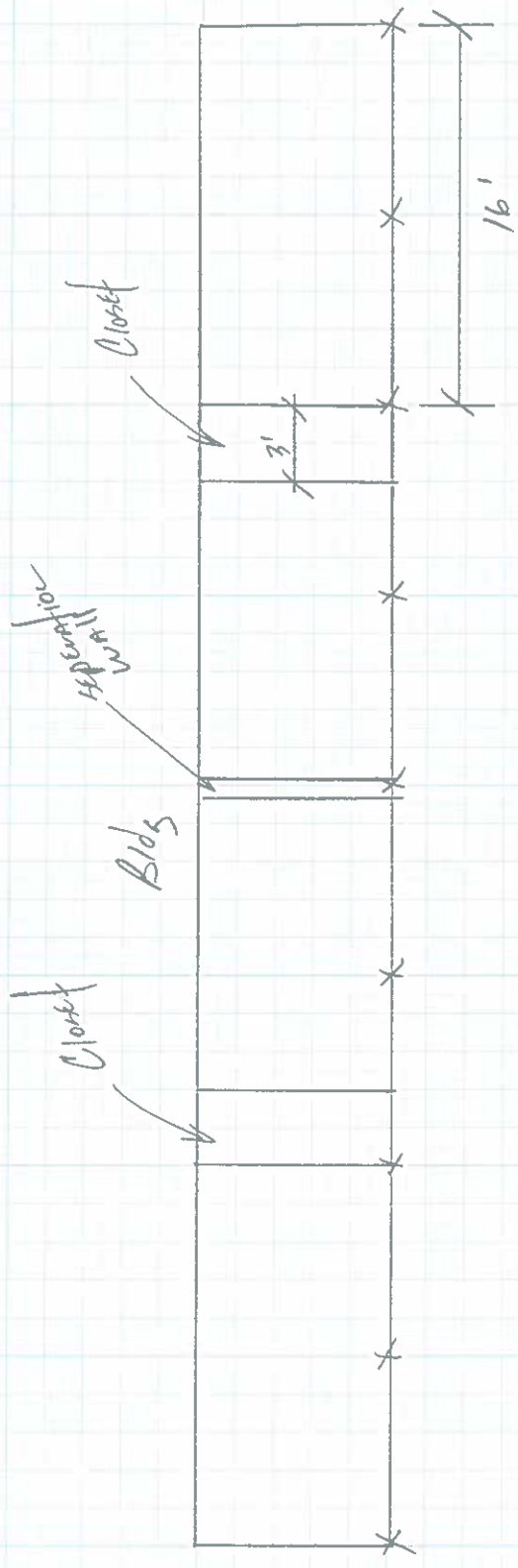

x = piers 8' OC Typical

ABBREVIATIONS

A.B.	ANCHOR BOLT	REQ'D.	REQUIRED
ADD'L	ADDITIONAL	RM.	ROOM
A.S.C.	AMERICAN INSTITUTE OF STEEL CONSTRUCTION	SECT.	SECTION
A.S.T.M.	AMERICAN SOCIETY FOR TESTING & MATERIALS	SHT.	SHEET
B.L.D.G.	BUILDING	SK.	SKYLIGHT
B.O.T.	BOTTOM OF	SM.	SHIM
B.S.M.T.	BASEMENT	S.P.C.	SPRINKLER
B.W.M.	BELTWAY	S.P.L.V.	SHORT LEG VERTICAL
C.B.	CORNER	S.P.C.	SPACE
C.H.	CHAMFER	S.P.C.	SPECIFICATION
C.I.	CONCRETE	S.P.C.	SPECIFICATION
C.M.U.	CONCRETE MASONRY UNIT	S.P.C.	SPECIFICATION
C.O.L.	COLUMN	S.P.C.	SPECIFICATION
C.O.N.G.	CONCRETE	S.P.C.	SPECIFICATION
C.O.N.T.	CONTINUOUS	S.P.C.	SPECIFICATION
C.O.N.T.R.	CONTRACTOR	S.P.C.	SPECIFICATION
C.W.	CURTAIN WALL	S.P.C.	SPECIFICATION
D.E.T.	DETAIL	S.P.C.	SPECIFICATION
D.I.A.G.	DIAGONAL	S.P.C.	SPECIFICATION
D.I.M.	DIMENSION	S.P.C.	SPECIFICATION
D.I.S.C.	DISCONTINUOUS	S.P.C.	SPECIFICATION
D.L.	DEAD LOAD	S.P.C.	SPECIFICATION
D.M.G.	DRAWING	S.P.C.	SPECIFICATION
E.F.T.	EACH FACE	S.P.C.	SPECIFICATION
E.L.E.	ELEVATION	S.P.C.	SPECIFICATION
E.L.E.C.T.	ELECTRICAL	S.P.C.	SPECIFICATION
E.O.	EQUAL	S.P.C.	SPECIFICATION
E.W.B.	END WALL BARS	S.P.C.	SPECIFICATION
E.W.P.	EACH WAY	S.P.C.	SPECIFICATION
E.X.P.	EXPANSION	S.P.C.	SPECIFICATION
E.X.P. J.N.T.	EXPANSION JOINT	S.P.C.	SPECIFICATION
E.X.T.	EXTERIOR	S.P.C.	SPECIFICATION
F.F.	FINISH	S.P.C.	SPECIFICATION
F.L.N.	FLOOR FINISH	S.P.C.	SPECIFICATION
F.O.B.	FACE OF BRICK	S.P.C.	SPECIFICATION
F.O.C.M.C.	FACE OF CONCRETE	S.P.C.	SPECIFICATION
F.O.N.	FACE OF WALL	S.P.C.	SPECIFICATION
F.S.	FLAT SLAB	S.P.C.	SPECIFICATION
F.T.	FOOT	S.P.C.	SPECIFICATION
F.T.G.	FOOTING	S.P.C.	SPECIFICATION
G.A.	GALVE	S.P.C.	SPECIFICATION
G.A.L.	GALVANIZED	S.P.C.	SPECIFICATION
G.L.	GLUE	S.P.C.	SPECIFICATION
G.R.	GRADE	S.P.C.	SPECIFICATION
H.A.S.	HEADED ANCHOR STUD	S.P.C.	SPECIFICATION
H.D.G.	HOT DIPPED GALVANIZED	S.P.C.	SPECIFICATION
H.S.S.	HIGH STRENGTH STEEL	S.P.C.	SPECIFICATION
H.S.S.	HOLLOW STRUCTURAL SECTION	S.P.C.	SPECIFICATION
I.D.	INSIDE DIAMETER	S.P.C.	SPECIFICATION
I.N.	INTERIOR	S.P.C.	SPECIFICATION
I.N.T.	INTERIOR	S.P.C.	SPECIFICATION
J.N.T.	JOINT	S.P.C.	SPECIFICATION
K.C.I.	KIP (1000 lbs.)	S.P.C.	SPECIFICATION
K.P.	KIP PER SQUARE INCH	S.P.C.	SPECIFICATION
L.B.	LINEAL FEET	S.P.C.	SPECIFICATION
L.I.N. FT.	LINEAL FEET	S.P.C.	SPECIFICATION
L.L.	LIVE LOAD	S.P.C.	SPECIFICATION
L.V.	VERTICAL	S.P.C.	SPECIFICATION
M.A.T.L.	MATERIAL	S.P.C.	SPECIFICATION
M.A.X.	MAXIMUM	S.P.C.	SPECIFICATION
M.E.C.H.	MECHANICAL	S.P.C.	SPECIFICATION
M.I.N.	MINIMUM	S.P.C.	SPECIFICATION
M.I.S.C.	MISCELLANEOUS	S.P.C.	SPECIFICATION
M.T.L.	METAL	S.P.C.	SPECIFICATION
N.O.M.	NOMINAL	S.P.C.	SPECIFICATION
N.O.T.	NOT TO SCALE	S.P.C.	SPECIFICATION
N.T.S.	NOT TO SCALE	S.P.C.	SPECIFICATION
O.C.	ON CENTER	S.P.C.	SPECIFICATION
O.D.	OUTSIDE DIAMETER	S.P.C.	SPECIFICATION
O.H.	OPPOSITE HAND	S.P.C.	SPECIFICATION
O.N.G.	OPENING	S.P.C.	SPECIFICATION
P.A.S.	PLATE	S.P.C.	SPECIFICATION
P.S.F.	POUND PER SQUARE FOOT	S.P.C.	SPECIFICATION
P.S.I.	POUND PER SQUARE INCH	S.P.C.	SPECIFICATION
R.	RADIUS	S.P.C.	SPECIFICATION
R.F.L.	REINFORCEMENT	S.P.C.	SPECIFICATION
R.F.N.	REINFORCEMENT	S.P.C.	SPECIFICATION
R.F.N.	REINFORCEMENT	S.P.C.	SPECIFICATION

GENERAL NOTES

- LOADS USED IN DESIGN:
 - A. DECK ----- 40 PSF
 - WOOD:
 - 1. ALL BEAMS AND JOISTS 2 TO 4 INCHES THICK SHALL BE PRESSURE TREATED SOUTHERN YELLOW PINE NO. 2 AND BETTER WITH F_b = 1,500 PSI AND E = 1,600,000 PSI.
 - 2. ALL POSTS AND COLUMNS 4" AND THICKER SHALL BE PRESSURE TREATED SOUTHERN YELLOW PINE NO. 2 WITH F_b = 625 PSF AND E = 1,500,000 PSI.
- FOUNDATION DESIGN IS BASED UPON AN ASSUMED BEARING PRESSURE:
 - A. ASSUMED SOIL BEARING PRESSURE ----- 1,500 PSF
 - B. EXAMINE EXCAVATION TO VERIFY BEARING PRESSURE AND SOIL CONDITIONS PRIOR TO CONSTRUCTION.
- ALL DIMENSIONS ON STRUCTURAL DRAWINGS TO BE VERIFIED WITH OWNER REQUIREMENTS AND EXISTING FIELD CONDITIONS. NOTIFY THE STRUCTURAL ENGINEER OF ANY DISCREPANCIES BEFORE PROCEEDING WITH CONSTRUCTION.

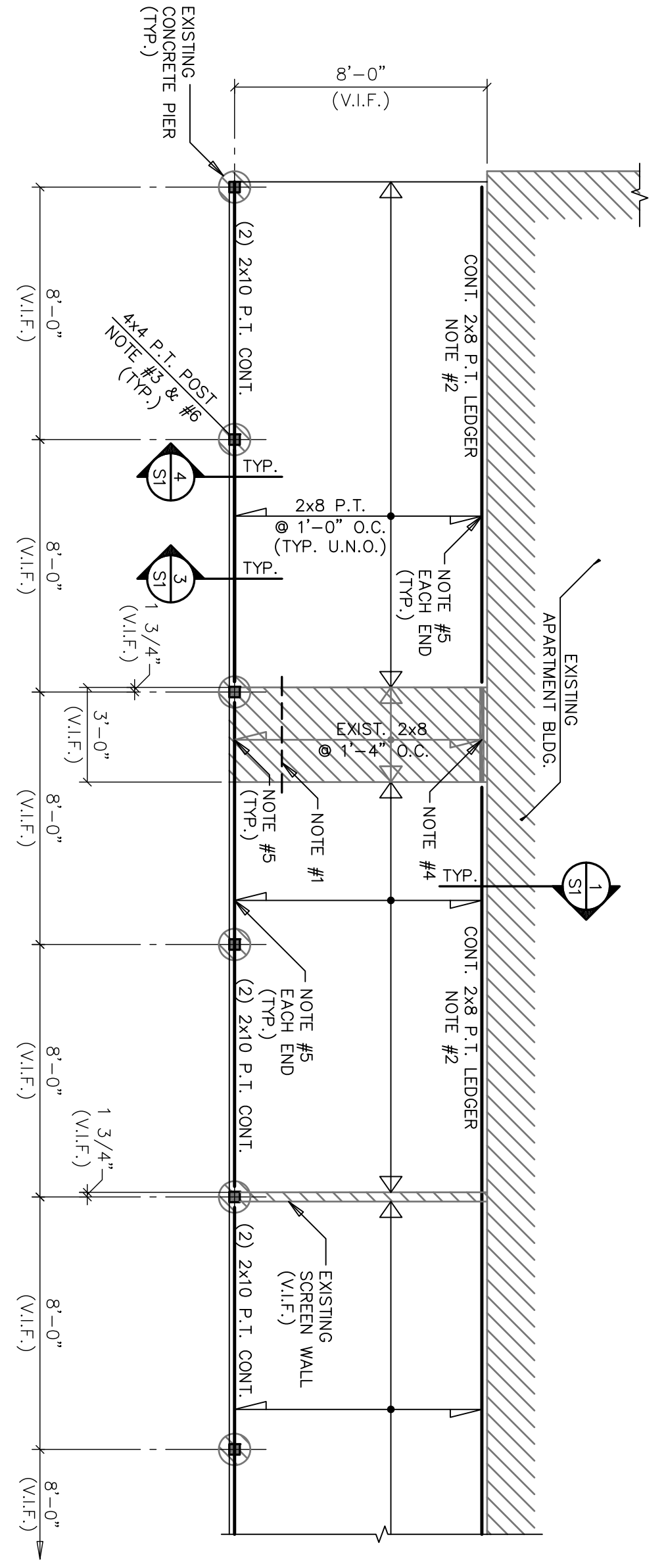

DECK FRAMING PLAN

- SHORE FRAMING UNDER EXISTING EXTERIOR CLOSET FRAMING AS REQUIRED.
- ATTACH 2x8 LEDGER TO EXISTING RIM JOIST W/ 3/4" THRU-BOLTS @ 2'-0" O.C. STAGGERED.
- PROVIDE 4x4 POST BASE ATTACH TO EXISTING CONCRETE PIER W/ 5/8" @ 4'-0" O.C. MAX.
- EXISTING LEDGERS & JOIST HANGERS TO REMAIN AT CLOSETS.
- PROVIDE TYPE "HUB8" HANGERS ATTACH W/ 1/2" NAILS PER MFR.
- PROVIDE TYPE "PC4Z" COLUMN CAP ("PC4Z" AT ENDS).

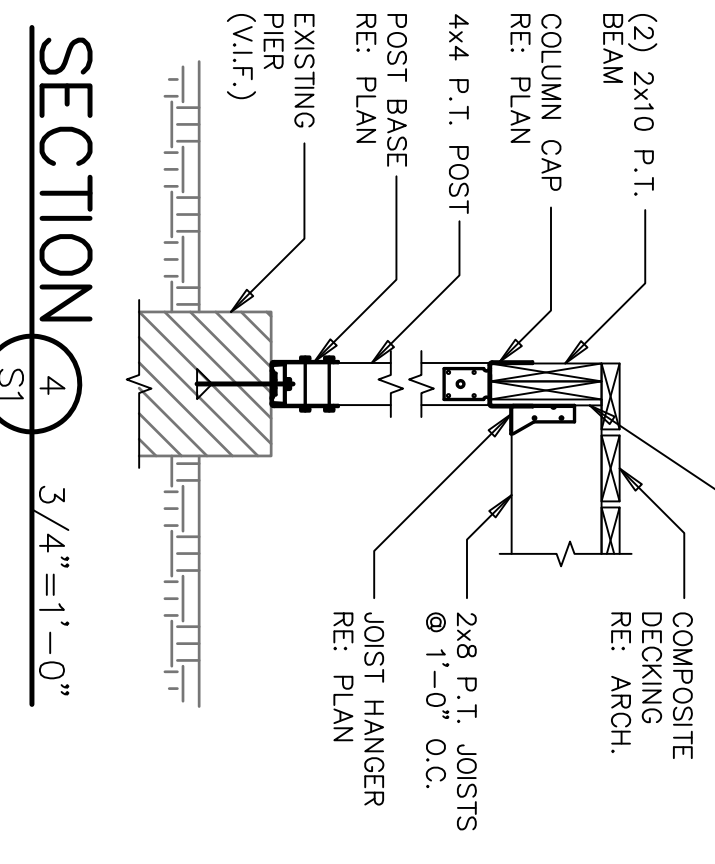
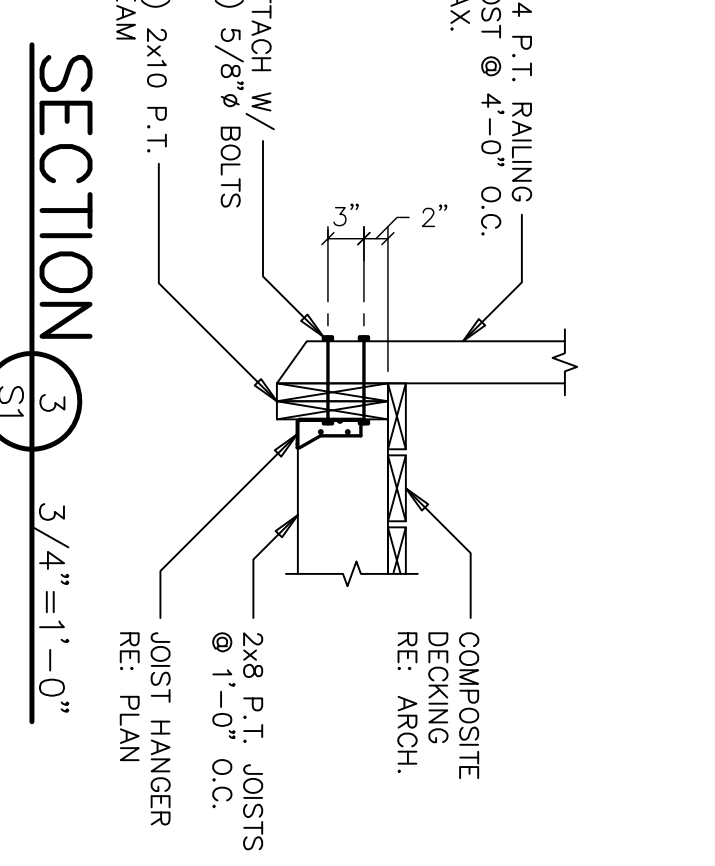
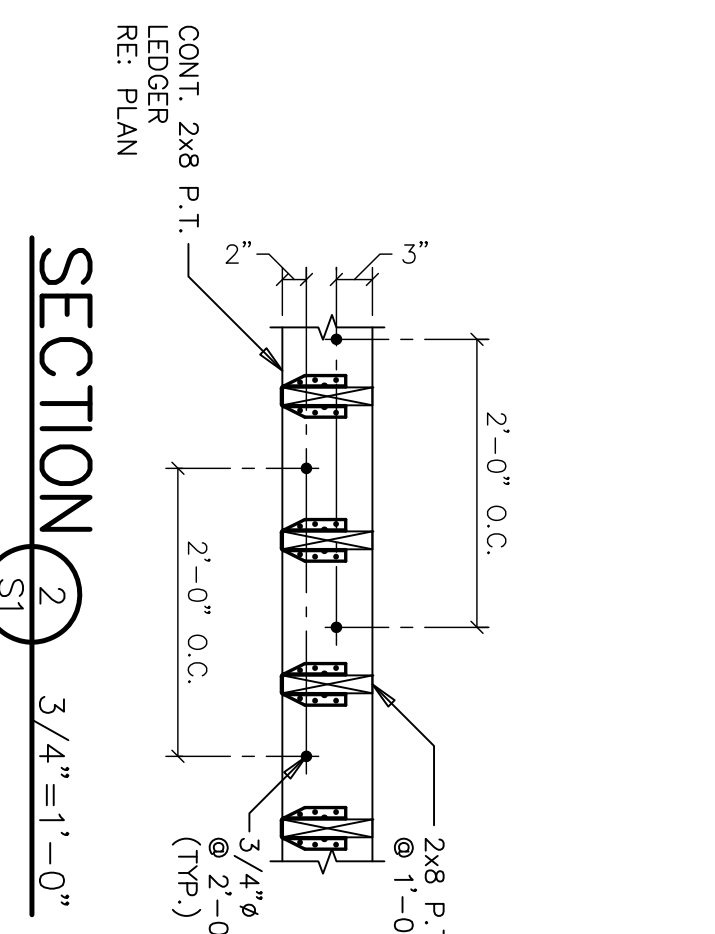
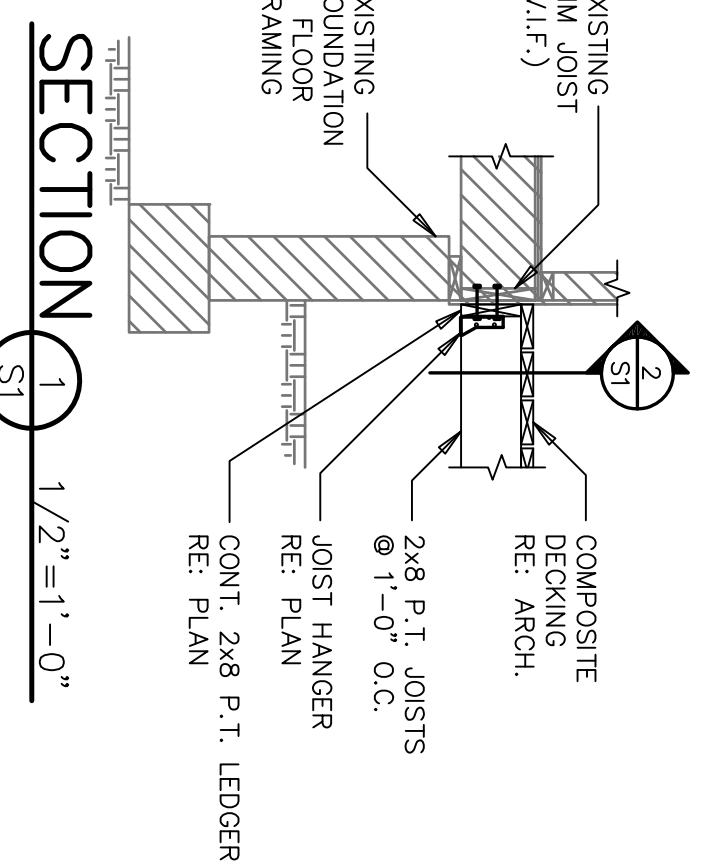

CRYSTAL BROOK APARTMENT DECKS

BLDG. 1760 & 1761
GRAND JUNCTION, COLORADO

Grand Junction Housing Authority

Lindauer • Dunn, Inc.
STRUCTURAL ENGINEERS
802 Road Avenue
Grand Junction, CO 81501
PHONE: 970-241-0900
FAX: 970-243-2430
www.lindauerdunn.com

REVISIONS:

JOB #	15.072
DRAWN BY:	JDG
CHECKED BY:	FNR
DATE:	07/17/15
SHEET #	

S1