



Purchasing Division

ADDENDUM NO. 2

DATE: September 8, 2016
FROM: City of Grand Junction Purchasing Division
TO: All Offerors
RE: Slough Excavation, Concrete Demo and Nesting for Las Colonias Park Project
IFB-4276-16-DH

Offerors responding to the above referenced solicitation are hereby instructed that the requirements have been clarified, modified, superseded and supplemented as to this date as hereinafter described.

Please make note of the following clarifications:

1. Contractor shall utilize the attached Revised Bid Schedule when submitting their bid for this project. See Attached.
2. Total volume of material that will be needed for the subgrade of the amphitheater seating area is 19,448 CY. Expected volume to be excavated from the slough is 28,976 CY.
3. Q. Stormwater Management and Dewater permitting. For those contractors bidding more than one of the three projects for the Las Colonias Park, are the contractors to include the cost of Stormwater management and dewatering permitting in each proposal? May we propose to have an allowance set for permitting and to have the permitting obtained and paid for out of said allowance?

A. The City has drafted and will supply the Construction Stormwater Management Plan. The City will apply and pay for both the Colorado Discharge Permit as well as the 5-2-1 Drainage permit. A dewatering permit is not anticipated.
4. Q. Local permitting, building and planning. Please confirm the contractor is to include in their proposal fee's associated with obtaining building permits and planning clearances for each project. If yes, will TCP fee's apply to these projects?

A. Local permitting, building, planning fees, and any other necessary permits/fees associated with construction shall be obtained and paid for by the Contractor. Traffic Capacity Payment (TCP) Fees do NOT apply to this project.

5. Q. It was discussed at the site visit meeting the City of Grand Junction will complete a portion of the site surveying. Would you please define the limits of the City's scope for the surveyors to provide competitive pricing for the contractor's responsibilities?
- A. The City will provide all construction staking for the slough project (excavation and embankment). The expected volume to be excavated from the slough is 28,976 CY. The expected volume to be placed and compacted to Subgrade Elevations in the amphitheater seating area is 19,448 CY. The remaining volume of 9,528 CY is to be hauled to the spoil area identified on the east side of the site. Subgrade is defined as Finish Grade less the final surfacing materials: 18" of topsoil in turf areas; 6" of landscape mulch in non-turf areas; appropriate depths of concrete sidewalk and concrete plaza area sections. The City will provide survey control for this work.
6. Q. Also, in reviewing the plans the quantities in the plans don't match up with the quantities said in the site-visit meeting. To just clarify please confirm the estimated quantities of dirt to be moved for each project.
- A. The estimated volume of 'materials' needed to complete the Amphitheater seating area is 28,263 CY, of which 19,448 CY will be brought over and compacted by the Slough Contractor for the subgrade for the seating area.

The remaining volume is comprised of concrete sidewalk and base that occurs on the seating mound, the 18" of topsoil that occurs under the lawn area, and the 6" of crusher fines that occurs on the slopes of the seating area mound. The Amphitheater contractor will be responsible for the above materials and their proper placement.

In addition to the above, the estimated volume of excavation related to the remainder of the amphitheater sitework (concrete plazas, parking, access roads, etc.) is 4,357 CY. This material will be hauled and placed in the stockpile area to the east, which is identified on the Slough drawings.

7. Addenda #1 included a pothole location map within the proposed slough area, but did not include the written log information that supported that map. That written log information is attached to this addenda #2.
8. See attached Construction Storm Water Management Plan and Site Map.
9. Contractor shall utilize the attached Revised Slough Bid Schedule when submitting their bid response.

The original solicitation for the project noted above is amended as noted.

All other conditions of subject remain the same.

Respectfully,

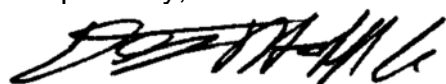

Duane Hoff Jr., Senior Buyer
City of Grand Junction, Colorado

Construction Storm Water Management Plan

For

Project: Las Colonias Amphitheater & Slough Construction

Project No.: _____

Project Code: _____

Owner: The City of Grand Junction

(970) 256-4082

CSWMP Preparer: Jerod Timothy, Project Manager

(970)-244-1565

Construction Storm Water Management Plan
For
Las Colonias Amphitheater & Slough Construction

Introduction

This CSWMP for the Las Colonias Amphitheater project is formatted and presented consistent with Mesa County SWMM and State of Colorado SWMP criteria, and local guidance provided by the 5-2-1 Drainage Authority. There are no exceptions to State required inclusions in the plan. The following CSWMP is organized and presented as follows:

Section 1: Site Description

Section 2: Site Map (Storm Water Site Map in Appendix A)

Section 3: Storm Water Management Controls

Section 4: Final Stabilization

Section 5: Inspection and Maintenance Procedures

Appendix A: Storm Water Site Map

Appendix B: Site Photos (existing conditions)

Appendix C: Storm Water Inspection Forms

This CSWMP was prepared by Jerod Timothy, Project Manager, City of Grand Junction, Grand Junction, CO 970-244-1565

1. Site Description

a) The nature of the construction activity at the site. The description should include the physical location and address or cross streets, type of project, a summary of the grading activities, installation of utilities, paving, excavation, landscaping, and the final disposition of the property.

This property is located at 925 Struthers Avenue in Grand Junction, Colorado, is intended to be developed as municipal recreational park. This project generally consists of the construction of the amphitheater structure which is to include curb, gutter, and sidewalk; asphalt and concrete pavement; utilities (water, sanitary sewer, storm sewer and electricity) and the slough excavation along the Colorado River. This work shall also include clearing and grubbing and the removal of concrete and asphalt. Disturbances will be limited to the areas within the property owned by the City of Grand Junction.

Material generated from the slough excavation is to be utilized in the fill section of the amphitheater. The excess material generated from excavation within the site shall be stockpiled onsite in a designated area for future use.

Final stabilization will include concrete and asphalt pavement with landscaping consisting of sod, seed, trees, shrubs and several xeriscape areas around the amphitheater, parking lots and trails shown on the included Storm Water Site Map in Appendix A.

b) The proposed sequence for major activities. Describe the sequence of events involved in the construction project, such as grading, excavation, final landscaping, etc.

1. Installation of tracking pads (Amphitheater Contractor), silt socks (Amphitheater Contractor), and earth windrow (Slough Contractor).
2. Clearing and grubbing of existing vegetation.
3. Slough excavation which includes the embankment of material at the amphitheater site.
4. Access/entry way construction along with trail construction.
5. Utility construction (water, sanitary sewer, storm sewer and electrical).
6. Vertical Construction of the amphitheater.
7. Construction of concrete curb, gutter and sidewalk.
8. Asphalt paving operations.
9. Revision of temporary Storm Water BMP's to accommodate final landscaping.
10. Complete all miscellaneous site grading in preparation of final stabilization.
11. Install landscape at all areas located behind top back of curb and sidewalk.
12. Install traffic signs and parking striping.
13. Removal of temporary BMP's and final cleaning of permanent BMP's.

c) Estimates of the total area of the site, and the area and location expected to be disturbed by clearing, excavation, grading, or other construction activities.

Entire Lot: 53.85 Acres. Area to be disturbed: 35.18 acres.

d) A summary of any existing data used in the development of the site construction plans or SWMP that describe the soil or existing potential for soil erosion.

According to the Natural Resources Conservation Service, the property consists of two types of soils. Massadona silty clay loam, 0 to 2% slopes and Bebeever and Green River Soils, and Riverwash, 0 to % slopes.

The type of soil at this site would be characterized as NRCS Type Ba and Ro soil. The City did have a soils investigation performed and the report is available if warranted. Information of the on-site soils was used in the development of the SWMP and BMP design.

e) A description of the existing vegetation at the site and an estimate of the percent vegetative ground cover.

Vegetation is minimal within the site boundary with exception of the slough alignment. The percentage of ground cover is estimated to be less than 20% (Native weeds & grasses).

f) The location and description of all potential pollution sources, including ground surface disturbing activities, vehicle fueling, storage of fertilizers or chemicals, etc.

During a large storm event, any sediment transported by Storm Water would most likely follow the current land contours which drain to the south/southeast to the Colorado River.

Construction operations will disturb soils causing potential for pollution. This exposed soil is a potential pollution source and will be handled with the placement of two stabilized construction entrances, installation of silt sacks at inlets on adjacent roadways and an earth windrow along the southerly boundary of the site.

The Contractor awarded the Slough Restoration Project shall be responsible for the construction of the earth windrow/berm prior to work commencing.

The Contractor awarded the Amphitheater Project which includes, but may not be limited to utility installation, amphitheater construction, roadway and parking lots, concrete trail and landscape shall be responsible for the installation of tracking pads and silt socks as shown on the Site Map. Initially the Contractor for the Access and Trail Construction will be responsible for the necessary inlet protection. Upon completion of this phase of work the Amphitheater Contractor shall place necessary inlet protection.

The Contractor awarded the Access and Trail Construction shall be responsible for the installation of silt sacks along Riverside Parkway.

Construction workers trash is a possible pollution source. The ECS shall inspect the site daily for trash that can be a pollution source to the waterways. Any loose trash on-site shall be cleaned up and properly disposed of on a daily basis.

It will be the ECS responsibility to designate a specific area for fueling construction equipment and for the portable toilet during this project. Once the ECS determine the best place for a fueling area, the ECS shall mark the location on the construction drawings herein. The fueling area shall exhibit Best Management Practices in order to minimize and/or eliminate the

potential of fuel spillage. Any spillage of fuel onto the ground shall be immediately cleaned up and the contaminated soil disposed of properly at the Mesa County Landfill. Refer to the Storm Water Management Manual.

There is the possibility that construction specific chemicals could be stored on site. These chemicals will have to be stored in a manner that protects the chemical containers from weather and the chemicals from spillage. It shall be the contractor's responsibility to protect any chemicals stored on site from spilling, leaking and wet weather. All chemicals stored on site shall be kept at least 300 feet away from the Colorado River.

g) The location and description of any anticipated allowable sources of non-Storm Water discharge at the site, e.g., uncontaminated springs, landscape irrigation return flow, construction dewatering, and concrete washout.

The contractor and/or ECS shall determine the location of the concrete washout facility prior to any concrete pours. At a minimum, the washout facility shall be at least 300-feet away from any of the surface waters present on-site. It is the responsibility of the contractor to maintain and clean out the washout facility when the capacity reaches 50%.

h) The name of the receiving water (s) and the size, type and location of any outfall(s). If the Storm Water discharge is to a municipal separate storm sewer system, the name of that system, the location of the storm sewer discharge, and the ultimate receiving water(s).

The majority of the Storm Water runoff generated from the project site will enter into a side channel of the Colorado River. The side channel conveys water to the southwest and merges with the Colorado River. The Colorado River is the ultimate receiving waters for runoff generated at the project site.

Runoff from the north side (Riverside Parkway and Struthers Avenue) will go to a curb drained by a storm inlet structure (marked on the map) to a Storm Water quality pond (marked on map), ultimately draining to the Colorado River.

The topography of the project site is relatively flat. It is believed that during construction the majority of Storm Water will not sheet flow, but instead percolate into the ground.

2. Site Map

The SWMP must include a site map showing the entire area and identifying the following components:

a) Construction site boundaries;

A construction site boundary (disturbance boundary) is shown on the Storm Water Site Map included in Appendix A.

b) All areas of ground surface disturbance;

Ground disturbance activities will be contained within the disturbance boundary shown on the Storm Water Site Map included in Appendix A.

c) Areas of cut and fill;

This project will generate approximately 45,000 cubic yards of cut material. Cut areas consist of the slough excavation (Approx. 29,000 cy) and underlying the amphitheater, parking lot and sidewalk locations.

Approximately 20,000 cy of cut material shall be utilized in the fill area of the amphitheater with the remainder being stockpile at the east end of the site as designated on the attached Storm Water Site Map.

d) Areas used for storage of building materials, equipment, soil, or waste;

Storage location of building materials, equipment, soil, or waste will be determined by the ECS. The Contractor shall note area on site map prior to implementing.

e) Locations of dedicated asphalt or concrete batch plants;

No dedicated asphalt or concrete batch plants will be located on this project site.

f) Locations of all structural BMPs;

See Storm Water Site Map in Appendix A for the locations of the structural BMP's.

g) Locations of non-structural BMPs as applicable; and

See Storm Water Site Map in Appendix A for the approximate locations of the non-structural BMP's.

h) Locations of springs, streams, wetlands and other surface waters.

See Storm Water Site Map in Appendix A for details in regards to the Las Colonias Amphitheater and Slough Construction Project.

3. Storm Water Management Controls

The SWMP must include a description of all Storm Water management controls that will be implemented as part of the construction activity to control pollutants in Storm Water discharges. The appropriateness and priorities of Storm Water management controls in the SWMP shall reflect the potential pollutant sources identified at the facility. The description of the Storm Water management controls shall address the following, at a minimum:

a) SWMP Administrator- The SWMP shall identify a specific individual(s), position, or title who is responsible for developing, implementing, maintaining, and revising the SWMP. The activities and responsibilities of the administrator shall address all aspects of the facility's SWMP.

Upon award of the contract(s) the Contractor shall designate an individual who will be responsible for the SWMP administration which shall include development, maintaining, implementing and revising the SWMP. The assigned SWMP administrator is the contact for all on-site SWMP-related issues and is the person responsible for its accuracy, completeness, and implementation, even though the "permittee" (City) carries legal liability. The SWMP Administrator shall be a qualified Erosion Control Supervisor, per 5-2-1 Drainage Authority policy.

The Contractor awarded the Slough Restoration Project shall be responsible for the construction of the earth windrow/berm prior to work commencing.

The Contractor awarded the Amphitheater Project which includes, but may not be limited to utility installation, amphitheater construction, roadway and parking lots, concrete trail and landscape shall be responsible for the installation of tracking pads and silt socks as shown on the Site Map. Initially the Contractor for the Access and Trail Construction will be responsible for the necessary inlet protection. Upon completion of this phase of work the Amphitheater Contractor shall place necessary inlet protection.

The Contractor awarded the Access and Trail Construction shall be responsible for the installation of silt sacks along Riverside Parkway.

b) Identification of Potential Pollution Sources- All potential pollutant sources, including materials and activities, at a site must be evaluated for the potential to contribute pollutants to Storm Water discharges. The SWMP shall identify and describe those sources determined to have the potential to contribute pollutants to Storm Water discharges, and the sources must be controlled through BMP selection and implementation, as required in paragraph (c) below. At a minimum each of the following sources and activities shall be evaluated for the potential to contribute pollutants to Storm Water discharges, and identified in the SWMP if found to have such potential:

1) all disturbed and stored soils;

Disturbed soils will be present during this project and will have the potential to contribute sediment to Storm Water runoff and contribute to windblown dust. All disturbed soils will be confined by the constructed earth windrow (berm) and all other necessary BMP's as shown on the SWMP within the construction plans or where deemed appropriate to protect the Colorado River from sediment runoff. As soon as it is practical, the Contractor shall start the final stabilization process.

Stockpiled materials will have adequate erosion protection at the base of the stockpile. ECS shall specify on the Site Map.

2) vehicle tracking of sediments;

Vehicle tracking of sediments is a potential pollutant source in Storm Water on this project.

A Stabilized construction entrance (tracking pad) shall be employed during construction. Refer to Storm Water Management Manual.

3) management of contaminated soils;

Presence of uranium mill tailings are an anticipated contaminate within the site. At no time will any material be permitted to leave the site. Excess material generated during construction shall be stockpiled in a designated area with the necessary BMP's implemented. The City has been in close contact with CDPHE throughout design and planning for the site management.

Any spillage of fuel or hydraulic fluid onto the ground shall be immediately cleaned up and the

contaminated soil disposed of properly at the Mesa County Landfill. The City of Grand Junction's Hazardous Materials Division shall be immediately contacted upon any major spillage of hazardous material. Call 970-244-1470 for Hazardous Material spills.

4) loading and unloading operations;

Loading and unloading operations will occur during this project and have the potential to contribute to dust and vehicle tracking onto the streets. Stabilized construction entrances (tracking pads) shall be employed during construction. The tracking pads shall be maintained throughout construction in order to maintain their cleaning effectiveness.

Note that no material generated from this project shall be removed from the site.

5) Outdoor storage activities (building materials, fertilizers, chemicals, etc.)

It is anticipated that the contractor will provide a construction trailer for this project. Due to the nature of this project, construction chemicals may be present on-site. Any of the materials to be installed or used for the construction of the amphitheater, parking lot and sidewalk improvements shall be stored in a designated area to be protected by 6 foot chain link fencing. Any contaminants shall be contained at all times within a spill proof and waterproof container when not being used. Chemicals shall not be stored within 300-feet of the Colorado River.

6) vehicle and equipment maintenance and fueling;

It is anticipated that equipment maintenance and possibly fueling will be done on-site. The contractor and ECS shall designate a specific location for fueling and maintenance of equipment.

7) significant dust or particulate generating processes;

The Contractor shall apply water as needed for dust control.

8) routine maintenance activities involving fertilizers, pesticides, detergents, fuels, solvents, oils, etc.;

It is anticipated that equipment maintenance and fueling will be done on-site. The contractor and ECS shall designate a specific location for fueling and maintenance of equipment. Management of contaminated soils as a result of equipment maintenance shall be handled per section 3 above, "management of contaminated soils."

9) On-site waste management practices (waste piles, liquid wastes, dumpsters, etc.);

Provide an on-site covered trash receptacle.

10) concrete truck/equipment washing, including concrete truck chute and associated fixtures and equipment;

A portable concrete washout facility may be used. Detail to be provided by the ECS.

11) dedicated asphalt and concrete batch plants;

No dedicated asphalt or concrete batch plants will be located on this project site.

12) non-industrial waste sources such as worker trash and portable toilets;

One portable toilet is required to be on-site. Location for the portable toilet shall be at least 300-feet from the surface waters and proper precautions taking to prevent from being windblown.

13) Other areas or procedures where potential spills can occur.

No other potential Storm Water discharges are known at this time.

c) Best Management Practices. The SWMP shall identify and describe appropriate BMPs, including, but not limited to, those required by paragraphs 1 through 8 below, that will be implemented at the facility to reduce the potential of the sources identified in part b, above, to contribute pollutants to Storm Water discharges. The SWMP shall clearly describe the installation and implementation specifications for each BMP identified in the SWMP to ensure proper implementation, operation, and maintenance of the BMP.

1. Structural Practices for Erosion Control. The SWMP shall clearly describe and locate all structural practices implemented at the site to minimize erosion and sediment transport. Practices may include, but are not limited to: straw bales, wattles/sediment control logs, silt fences, earth dikes, drainage swales, sediment traps, subsurface drains, pipe slope drains, inlet protection, outlet protection, gabions, and temporary or permanent sediment basins.

1. Stabilized Construction Entrance (tracking pad): Reference the preliminary location, design, installation, and maintenance of the tracking pad on the Storm Water Site Map. The tracking pad may need to be lengthened during construction if the dimensions provided in the plans are not adequate for sediment removal from vehicle tires. The tracking pad need to be installed before any construction vehicles start entering and leaving the site for hauling operations.
2. Earth Windrow (Berm): Reference the location, design, installation, and maintenance of the berm on the Storm Water Site Map. The contractor shall construct berm per the details shown on the Storm Water Site Map. It is the responsibility of the contractor to maintain the berm when/if damaged.
3. Concrete Washout Facility: The contractor and/or ECS shall determine the location of the concrete washout facility prior to any concrete pours. At a minimum, the washout facility shall be at least 300-feet away from any of the surface waters present on-site. It is the responsibility of the contractor to maintain the washout facility.
4. Silt Sack (Inlet Protection): Shall be installed at locations shown on SWAP map. Regular maintenance/cleaning is required throughout construction.

2) Non-Structural Practices for Erosion and Sediment Control. The SWMP shall clearly describe and locate, as applicable, all non-structural practices implemented at the site to minimize erosion and sediment transport. Description must include interim and permanent stabilization practices, and site-specific scheduling for implementation of the practices. The SWMP should include practices to ensure that existing vegetation is preserved where possible. Non-structural practices may include, but are not limited to: temporary vegetation, permanent vegetation, mulching, geotextiles, sod stabilization, slope roughening, vegetative buffer strips, protection of trees, and preservation of mature vegetation.

1. Dust Abatement: Watering operations to reduce windborne dust. Dust abatement will be used throughout the course of this construction project.

2. Landscaping: Structural BMP's will be completed with landscaping.
3. Preserving Native Vegetation: Minimize existing vegetation disturbance.

3) Phased BMP Implementation The SWMP shall clearly describe the relationship between the phases of construction, and the implementation and maintenance of both structural and non-structural Storm Water management controls. The SWMP must identify the Storm Water management controls to be implemented during the project phases, which can include, but are not limited to, clearing and grubbing; road construction; utility and infrastructure installation; vertical construction; final grading; and final stabilization.

1. Slough Excavation/Material Embankment: The Contractor shall construct the windrow/berm prior to clearing and grubbing, slough construction and placement of embankment. During construction of the slough the downstream end at the Colorado River shall not be excavated until this phase of work is complete. This earth dam will serve as a BMP preventing any sediment from making its way into the Colorado River. A maintenance and fueling location shall be identified prior to work commencing and shall be noted on the SWAMP map.
2. Amphitheater and site civil construction (utilities, roadways, parking lots, sidewalk, etc.): The contractor shall install tracking pads and siltsacks as shown on the Storm Water Site Map. The windrow/berm shall be in place prior to this phase. This work shall include, but may not be limited to the locations identified for maintenance and fueling operations, trash receptacles, sanitary facility, concrete washout, material storage and any other necessary controls for construction operations.

4) Materials Handling and Spill Prevention. The SWMP shall clearly describe and locate all practices implemented at the site to minimize impacts from procedures or significant materials that could contribute pollutants to runoff. Such procedures or significant materials could include: exposed storage of building materials; paints and solvents; fertilizers or chemicals; waste material; and equipment maintenance or fueling procedures. Areas or procedures where potential spills can occur must have spill prevention and response procedures identified in the SWMP.

Presence of uranium mill tailings are an anticipated contaminate within the site. At no time will any material be permitted to leave the site. Excess material generated during construction shall be stockpiled in a designated area with the necessary BMP's implemented.

The City has been in close contact with CDPHE throughout design and planning for the site management. Any spillage of fuel or hydraulic fluid onto the ground shall be immediately cleaned up and the contaminated soil disposed of by direction of the Project Engineer as well as a representative of the CDPHE. The City of Grand Junction's Hazardous Materials Division shall be immediately contacted upon any major spillage of hazardous material. Call 970-244-1470 for Hazardous Material spills. Refer to the Storm Water Management Manual.

The contractor will be responsible for providing spill clean-up materials and spill prevention and response procedures. The spill prevention and pollution control plans developed by the contractor must be available on-site at all times. The ECS shall refer to section 208.06, Materials Handling and Spill Prevention, of the CDOT specifications for developing the materials and spill prevention response procedure.

5) Dedicated Concrete or Asphalt Batch Plants. The SWMP shall clearly describe and locate all practices implemented at the site to control Storm Water pollution from dedicated concrete batch plants or dedicated

asphalt batch plants covered by this certification.

No dedicated asphalt or concrete batch plants will be located on this project site.

6) Vehicle Tracking Control. The SWMP shall clearly describe and locate all practices implemented at the site to control potential sediment discharges from vehicle tracking. Practices must be implemented for all areas of potential vehicle tracking, and can include: minimizing site access; street sweeping or scraping; tracking pads; graveled parking areas; requiring that vehicles stay on paved areas on-site; wash racks; contractor education; and/or sediment control BMPs, etc.

During construction there will be two designated locations for access to the project site. These locations have been identified on the Storm Water Site Map. Tracking pads shall be installed to the minimum dimensions and details shown on the Storm Water Site Map.

7) Waste Management and Disposal, Including Concrete Washout. The SWMP shall clearly describe and locate the practices implemented at the site to control Storm Water pollution from all construction site wastes (liquid and solid), including concrete washout activities. The practices used for concrete washout must ensure that these activities do not result in the contribution of pollutants associated with the washing activity to Storm Water runoff. The SWMP shall clearly describe and locate the practices to be used that will ensure that no washout water from concrete washout activities is discharged from the site as surface runoff or to surface waters.

The contractor will be required to provide one portable toilet for the duration of the project and it shall be maintained throughout construction.

A covered trash receptacle is required.

The concrete washout facility shall be at least 300-feet away from any of the surface waters present on-site. It is the responsibility of the contractor to maintain the washout facility.

8) Groundwater and Storm Water Dewatering. The SWMP shall clearly describe and locate the practices implemented at the site to control Storm Water pollution from the dewatering of groundwater or Storm Water from excavations, wells, etc. Part I.D.3.d of the permit authorizes the conditional discharge of construction dewatering to the ground. For any construction dewatering of groundwater not authorized under a separate CDPS discharge permit, the SWMP shall clearly describe and locate the practices to be used that will ensure that no groundwater from construction dewatering is discharged from the site as surface runoff or to surface waters.

It is anticipated that groundwater will be encountered during certain phases of construction. Dewatering operations shall consist of the water being captured and released utilizing a sprinkler or other approved methods in designated areas within the construction site. Dewatering operations shall be in compliance with Part I.D.3.d of the permit.

4. Final Stabilization and Long-term Storm Water Management

a) The SWMP shall clearly describe the practices used to achieve final stabilization of all disturbed areas at the site, and any planned practices to control pollutants in Storm Water discharges that will occur after construction operations have been completed at the site. b) Final stabilization practices for obtaining a vegetative cover should include, as appropriate: seed mix selection and application methods; soil preparation and amendments; soil stabilization practices (e.g. crimped straw, hydro mulch or rolled erosion control products); and appropriate sediment control BMPs as needed until final stabilization is achieved; etc.

See landscape plans for details in regards to final stabilization and BMP implementation during this phase.

c) Final stabilization is reached when all ground surface disturbing activities at the site have been completed, and uniform vegetative cover has been established within an individual plant density of at least 70 percent of pre-disturbance levels, or equivalent permanent, physical erosion reduction methods have been employed.

Final stabilization will be achieved by landscaping detailed on the landscaping plans.

5. Inspection and Maintenance Procedures

a) The SWMP shall clearly describe the inspection and maintenance procedures implemented at the site to maintain all erosion and sediment control practices and other protective practices identified in the SWMP, in good and effective operation condition.

1. The ECS shall at a minimum inspect and document the project Storm Water management system every 14 days and within 24 hours after a precipitation or snowmelt event that causes erosion.
2. The inspections shall include but not limited to observation of:
 - The construction site perimeter and discharge points (including discharges into a storm sewer system)
 - All disturbed areas and making sure the proper BMP is being used, is in the right location, and is installed per the plans.
 - Areas used for material/waste storage that are exposed to precipitation.
 - Other areas determined to have a significant potential for Storm Water pollution, such as the concrete washout facility, tracking pad, and the areas adjacent to Colorado River.
 - Erosion and sediment control measures identified on the Storm Water Site Map.
 - The inspection must determine if there is evidence of, or the potential for, pollutants entering the drainage system.
 - BMP's should be reviewed to determine if they still meet the design and operational criteria in the SWMP, and if they continue to adequately control the Storm Water runoff at the site.

APPENDIX A
Storm Water Site Map

APPENDIX B

Existing Site Photos (Pre-construction)



- 1) Looking east towards the intersection of Struthers Avenue and South 9th Street. Install stabilized construction entrance and silt sack at inlet structure.



2) Looking south from the northwest corner of proposed Las Colonias Amphitheater site. Proposed main entrance to amphitheater.



3) Photo looking east from northwest corner of proposed Las Colonias Amphitheater site. Amphitheater, parking lot and roadway to be located in this vicinity.



4) Photo looking east from the southwest corner of proposed Las Colonias Amphitheater site.



- 5) Looking east along the southerly boundary of project site. Construct earth windrow/berm along boundary as shown on Storm Water Site Map.



- 6) Looking northwest along southerly boundary of project site. Construct earth windrow/berm along boundary as shown on Storm Water Site Map.

APPENDIX D

Storm Water Inspection Forms

(Available Online)

DURING CONSTRUCTION (TEMPORARY MEASURES)

1. INLET BASIN PROTECTION –PRIOR TO CONSTRUCTION THE CONTRACTOR SHALL INSTALL A TEMPORARY INLET BASIN FILTER. THE INLET BASIN FILTERS SHALL REMAIN IN PLACE UNTIL THE PROJECT HAS BEEN COMPLETELY PAVED AND ALL DIRT MOVING OPERATIONS ARE COMPLETE. THE FILTERS SHALL BE MAINTAINED BY THE CONTRACTOR, AND THE FILTER SHALL BE EITHER REPLACED OR CLEANED WHEN THE FILTER CAPACITY REACHES 50% OF THE TOTAL CAPACITY.
2. VEHICLE TRACKING –THE CONTRACTOR SHALL STAGE DAILY USE VEHICLES ON EXISTING ASPHALT SURFACE AS MUCH AS POSSIBLE TO LIMIT VEHICLE TRACKING ONTO ROADWAY SURFACE. AS A MINIMUM A VEHICLE TRACKING PAD SHALL BE INSTALLED AT THE ENTRANCE/EXIT TO THE PROPOSED PARKING LOT.

AFTER CONSTRUCTION (PERMANENT MEASURES)

1. SODING/SEED/XERISCAPE- AREAS DISTURBED BEHIND THE TOP BACK OF CURB AND SIDEWALK SHALL BE STABILIZED UTILIZING ONE OF THE THREE METHODS MENTIONED OR AS DIRECTED PER PLAN.

GENERAL NOTES:

1. THE SWMP ESTABLISHES THE MINIMUM ACCEPTABLE REQUIREMENTS FOR STORM WATER POLLUTION PREVENTION ON SITE. THE CONTRACTOR MAY SUPPLEMENT THESE REQUIREMENTS AS APPROPRIATE FOR SPECIFIC CONSTRUCTION ACTIVITIES AND DIFFERENT STAGES OF CONSTRUCTION. ANY CHANGES TO THE PRACTICES SHOWN ON THIS PLAN MUST BE REVIEWED BY THE PROJECT INSPECTOR/MANAGER PRIOR TO IMPLEMENTATION.
2. A COPY OF THE SWMP, STORM WATER PERMITS AND CONSTRUCTION PLANS SHALL BE MAINTAINED ON SITE AT ALL TIMES.

MAINTENANCE

1. THE CONTRACTOR'S EROSION CONTROL SUPERVISOR SHALL MAKE ROUTINE CHECKS ON ALL EROSION CONTROL MEASURES TO DETERMINE IF REPAIRS OR SEDIMENT REMOVAL IS NECESSARY.
2. AFTER EACH RAINFALL OR MODERATE SNOW MELT, EROSION CONTROL MEASURES ARE TO BE CHECKED BY THE EROSION CONTROL SUPERVISOR. IF REPAIRS ARE NEEDED, THEY SHALL BE COMPLETED IMMEDIATELY.
3. SILT AND SEDIMENT SHALL BE REMOVED WHEN THEY REACH A HEIGHT OF ONE-HALF OF THE BARRIER (CHECK DAM, SILT FENCE, ANCHORED STRAW BALE OR EROSION CONTROL LOG).
4. WHEN TEMPORARY MEASURES ARE TO BE REMOVED, ANY SILT AND SEDIMENT DEPOSITS SHALL BE REMOVED AND SPREAD EVENLY IN FILL AREAS.

GENERAL NOTES

1. AT ALL TIMES DURING CONSTRUCTION, EROSION AND SEDIMENT CONTROL SHALL BE MAINTAINED BY THE CONTRACTOR OR HIS EROSION CONTROL SUPERVISOR.
2. EROSION CONTROL SYSTEM SHALL BE INSTALLED AS GRADING PROGRESSES.
3. DETAILS SHOWN ARE SCHEMATIC ONLY. ADJUST AS NECESSARY TO FIT FIELD CONDITIONS.
4. NEGATIVE IMPACTS TO DOWNSTREAM AREAS (OR RECEIVING WATERS) CAUSED BY THE SLOPE GRADING TO BE MONITORED AND CORRECTED BY THE CONTRACTOR AND/OR EROSION CONTROL SUPERVISOR.

NOTE:

1. THE CONTRACTOR SHALL MAINTAIN THIS SET OF SWMP PLANS FOR REDLINING AND CONTINUOUSLY UPDATING THE PLANS TO SHOW THE CURRENT BMP'S BEING USED AND WHY. THIS REDLINED SET OF THE SWMP SHALL BE KEPT ONSITE AT ALL TIMES AND AVAILABLE FOR INSPECTION BY THE PROJECT ENGINEER, PROJECT INSPECTOR AND REGULATORY ENFORCEMENT PERSONNEL.
2. BEFORE CONSTRUCTION STARTS, THE ECS AND THE CONTRACTOR NEED TO DETERMINE THE MOST LOGICAL LOCATION FOR THE EQUIPMENT FUELING AND MAINTENANCE AREA. THE FUELING AND MAINTENANCE AREA NEEDS TO BE A MINIMUM OF 100- FEET AWAY FROM ANY SURFACE WATER FEATURE. THE ECS SHALL LABEL ON THE SWMP THE LOCATION OF THE FUELING/MAINTENANCE AREA.

GENERAL NOTES:

1. THE CONTRACTOR SHALL ASSIGN TO THE PROJECT AN INDIVIDUAL TO SERVE IN THE CAPACITY OF THE EROSION CONTROL SUPERVISOR (ECS). THE ECS SHALL BE EXPERIENCED IN ALL ASPECTS OF CONSTRUCTION AND HAVE SATISFACTORILY COMPLETED AN ECS TRAINING PROGRAM AUTHORIZED BY THE 521 DRAINAGE AUTHORITY. PROOF THAT THIS REQUIREMENT HAS BEEN MET SHALL BE SUBMITTED TO THE ENGINEER PRIOR TO CONSTRUCTION STARTING. THE ECS SHALL ACT AS THE SWMP ADMINISTRATOR ON THE PROJECT.
2. THE CONTRACTOR MAY USE AN AREA ON SITE DESIGNATED AT THE PRECONSTRUCTION MEETING FOR CONSTRUCTION STAGING AND MATERIALS STORAGE. THE CONTRACTOR MAY OBTAIN OTHER AREAS FOR STAGING AND STORAGE, BUT WILL HAVE TO AMEND THE STORM WATER MANAGEMENT PLAN ACCORDINGLY.
3. THE CONTRACTOR CAN EXCAVATE A BASIN FOR THE WASHING OUT OF CONCRETE TRUCKS. WATER FROM THE BASIN MAY BE APPLIED TO THE ROADWAY BASE OR SUBBASE, OUTSIDE OF AREAS TO BE SEEDED OR LANDSCAPED, IN A MANNER SO THE WATER DOES NOT POND OR FLOW OFF. A PORTABLE CONCRETE WASHOUT FACILITY IS ALSO ACCEPTABLE.
4. THE CONTRACTOR SHALL KEEP ALL FUELING AND LUBRICATING OPERATIONS ON THE EAST SIDE OF LEACH CREEK AT LEAST 50 FEET EAST OF DRAINAGE CHANNEL. BECAUSE INDIVIDUAL BMP'S ARE NOT SHOWN FOR EACH LOCATION, THE CONTRACTOR SHALL NOTE ON THE CONSTRUCTION PLANS THE LOCATIONS AND TYPES OF BMP'S AS THEY ARE INSTALLED AND IMPLEMENTED.
5. PROVIDE SEDIMENT MIGRATION CONTROLS FOR ALL STOCKPILES OF MATERIALS USING WATTLES, SILT FENCES, GRADING CONTROLS, AND OTHERS.
6. PREVENT WIND EROSION VIA DUST CONTROL MEASURES. PROVIDE STREET SWEEPING FOR FUGITIVE SEDIMENT NOT CONTAINED VIA OTHER BMP'S.
7. MANAGE STORMWATER RUN-ON USING MEASURES SUCH AS EROSION LOGS, WATTLES, GRADING CONTROLS, BYPASSES AND OTHERS.
8. PROTECT ALL INLETS WITH INLET SILT SACKS PER DETAIL.

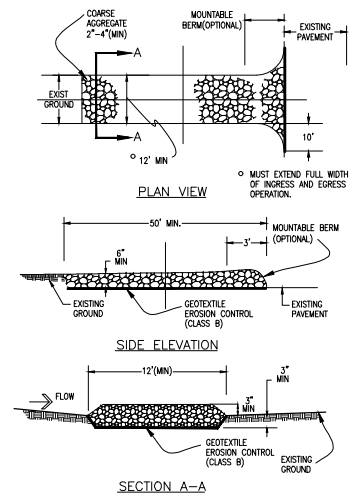

STABILIZED CONSTRUCTION ENTRANCE

Contractor shall construct a stabilized construction entrance at this location.

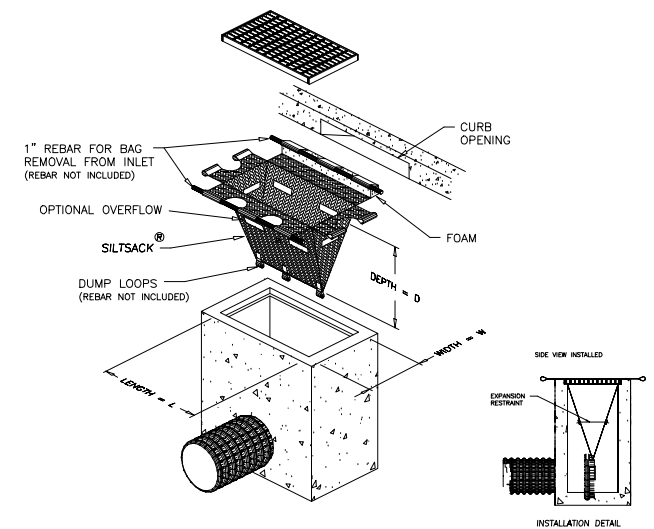

NOTE: THE SILTSACK WILL BE MANUFACTURED FROM A WOVEN POLYPROPYLENE FABRIC THAT MEETS OR EXCEEDS THE FOLLOWING SPECIFICATIONS.

SILTSACK OR EQUIVALENT

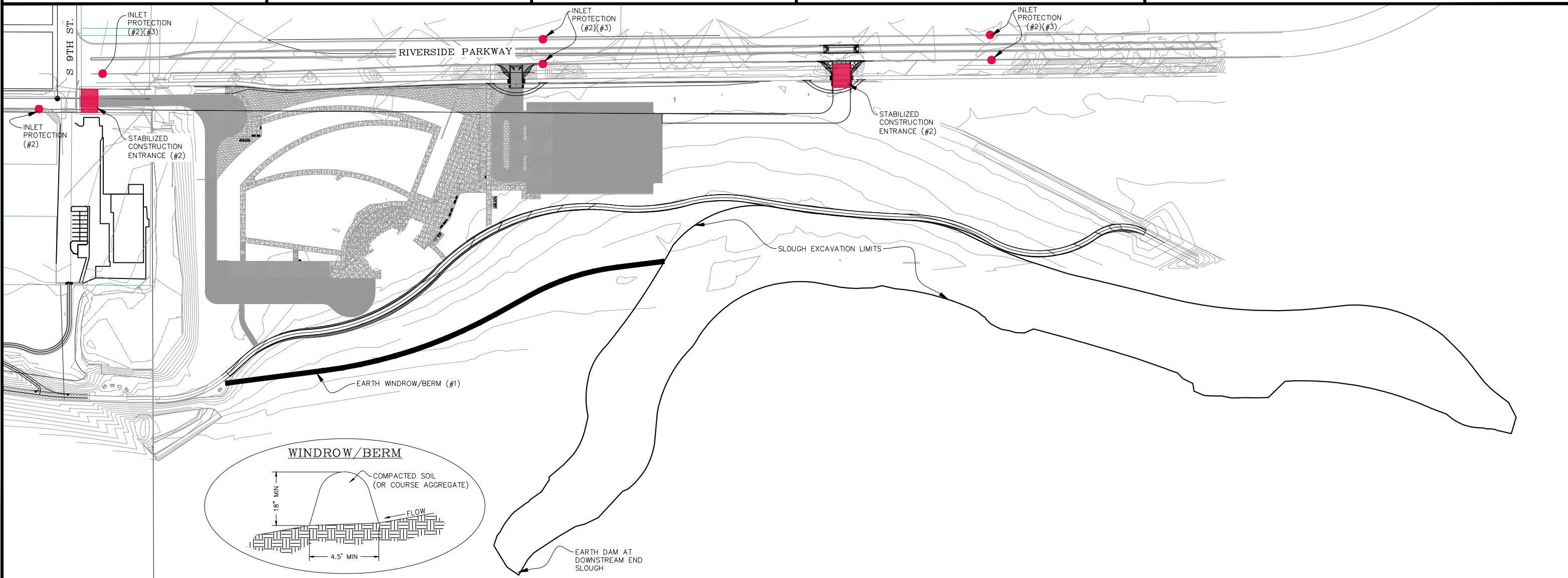

REVISION	DESCRIPTION	DATE
REVISION Δ		
REVISION Δ		
REVISION Δ		
REVISION Δ		

DRAWN BY	HMC	DATE	2016
DESIGNED BY	JKT	DATE	2016
CHECKED BY		DATE	
APPROVED BY		DATE	

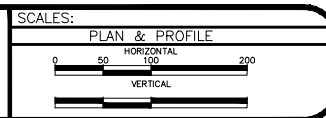

PUBLIC WORKS AND UTILITIES ENGINEERING DIVISION

LAS COLONIAS STORM WATER SITE MAP

N:\Landproj\2016 Las Colonias Phase II\DWG\LC_Phase II_SWMP.dwg Layout1, 9/8/2016 3:32:09 PM

BID SCHEDULE

The Construction Contract is known as:

LAS COLONIAS PARK SLOUGH RESTORATION PROJECT

PART 1 BID SCHEDULES

1.1 BASE BID

The Base Bid covers work required to complete the project as specified in the plans and technical specifications. Represented in the Bid Schedule as bid item numbers 1-16 and 23-25

1.2 ADD ALTERNATIVE BID: DEMO, HAUL, and PLACE EXISTING CONCRETE PATH

Bid covers work required to complete Add Alternative: Demo, haul, and place existing concrete path as specified in the plans and technical specifications. Represented in the Bid Schedule as bid item numbers 17 and 18

1.3 ADD ALTERNATIVE BID: WATSON ISLAND SLOUGH CONTROL STRUCTURE

Bid covers work required to complete Add Alternative: Watson Island Slough Control Structure as specified in the plans and technical specifications. Represented in the Bid Schedule as bid item numbers 19-22

1.4 ADD ALTERNATIVE BID: TOPSOIL and EROSION CONTROL BLANKETS

Bid cover work required to complete Add Alternative: Topsoil and Erosion Control Blankets as specified in the plans and technical specifications. Represented in the Bid Schedule as bid item numbers 26 and 27

1.5 ADD ALTERNATIVE BID: SEEDING AND WILLOW POLES

Bid cover work required to complete Add Alternative: Seeding and Willow Poles as specified in the plans and technical specifications. Represented in the Bid Schedule as bid item numbers 23, 24, and 25.

Cost is for all work basic to the Contract. The estimated quantities and prices are as follows:

Las Colonias Park Slough Restoration Project Bid Schedule

Bid Item No.	CDOT Spec. Ref.	Description	Quantity	Units	Unit Price	Total Price	Totals
		Site Preparation					
1		Mobilization/Demobilization/Bonding/Insurance	1	LS			

2		Construction Survey/Stake/As-built	NA	NA			
3		Trail/Pedestrian signage	1	LS			
					Sub Total:		
		Erosion Control and Care of Water					
4		General Staging Area BMPs	1	LS			
5		Care of Water Practices	1	LS			
6		Haul Route Maintenance	1	LS			
					Sub Total:		
		Construction					
7	201	Clearing and Grubbing	3	AC			
8		Excavation and transport to disposal areas	28,976	CY			
9		Disposal area rough grading	19,448	CY			
10		Selective sorting and stockpiling of alluvium	1,972	CY			
11		Grading of riffles with coarse cobble alluvium	1,904	CY			
12		Install coarse cobble riffle inlet for slough split	26	CY			
12		Furnish and place 36" boulder	573	TONS			
13		Backfill boulder with general alluvium	67	CY			
14	202	Miter, haul off, and dispose of 30" storm pipe	170	LF			
15		Furnish and Install outfall structure for 30" storm pipe	161	TONS			
16		Furnish and install non-woven filter fabric beneath boulder/riprap	364	SY			
					Sub Total:		
		Construction - Add Alternative					
		Add Alternative: Demo, Haul, and Place Existing Concrete Path					
17		Deconstruct concrete path	200	CY			

18		Transport/place concrete to disposal area	200	CY			
		Add Alternative: Watson Island slough control structure					
19		Excavate and transport to disposal area	106	CY			
20		Furnish and place 36" boulder	300	TONS			
21		Furnish and install non-woven filter fabric beneath boulder	132	SY			
22		Backfill boulder with general alluvium	26	CY			
					Sub Total:		
		Bio-engineering – Add Alternatives					
		Add Alternative: Seeding and Willow Poles					
23		Furnish and install riparian native seed mix	2.00	AC			
24		Furnish and install wetland native seed mix	2.60	AC			
25		Furnish and install dormant willow poles	3,500	SY			
					Sub Total:		
		Add Alternative: Topsoil and Erosion Control Blankets					
26		Erosion Control Blankets	3,500	SY			
27		Topsoil Import and Grading	583	CY			
					Sub Total:		
		TOTAL SUM BID					
		BASE BID					
		ADD ALTERNATIVE: DEMO, HAUL, AND PLACE EXISTING CONCRETE PATH					
		ADD ALTERNATIVE: WATSON ISLAND SLOUGH CONTROL STRUCTURE					
		ADD ALTERNATIVE: SEEDING AND WILLOW POLES					
		ADD ALTERNATIVE: TOPSOIL AND EROSION CONTROL BLANKETS					

PART 2 MEASUREMENT AND PAYMENT

2.1 GENERAL

A. ENGINEER will take all measurements and compute all quantities.

B. CONTRACTOR will verify measurement and quantities.

C. CONTRACTOR will provide all equipment, workers, and survey crews to assist ENGINEER in making measurements.

D. Units of measurement are listed above in the bid schedule(s).

E. Refer to Technical Specifications and Details for more detailed information to the following bid items, if applicable.

F. Bids shall encompass all costs associated with each bid item. This includes, but is not limited to planning, measuring, locating, surveying, executing, supplying, testing, cleaning, protecting, and finalizing Work and any and all incidentals. Bids shall include all costs associated with purchasing all materials necessary to complete Work. Bids shall encompass all costs associated with minimizing impacts upon the natural environment during any and all construction activities, including delays associated with sequencing.

G. Payment for all Lump Sum (LS) items will be made on a percentage basis as follows.

Percent of Original Contract Amount Earned	Percent of Amount Bid Item to be Paid
5	20
15	20
40	20
60	20
100	20

2.2 BID ITEM DESCRIPTIONS

Bid Item No. 1

MOBILIZATION/DEMOBILIZATION/BONDING/INSURANCE

A. Measurement is per Lump Sum (LS).

B. Work includes, but is not limited to: providing all required bonds and insurance; mobilization; demobilization; installation of temporary work area facilities; protecting in place vegetation and utilities, bringing and removing all necessary construction equipment to and from the site; obtaining construction permits; any and all incidentals; and restoration of site and disturbed areas to pre-construction conditions.

Bid Item No. 2

CONSTRUCTION SURVEY/STAKE/AS-BUILT

Work to be completed by OWNER

Bid Item No. 3

TRAIL/PEDESTRIAN SIGNAGE

A. Measurement is per Lump Sum (LS).

B. Payment covers the complete installation and removal of any and all signage required to inform pedestrian traffic of construction activities and provide detour information if necessary. Detour route to be supplied by OWNER. Work includes, but is not limited to: purchasing and delivery of all materials; delays; removal of work; and any and all incidentals.

Bid Item No. 4

GENERAL STAGING AREA BMP's

A. Measurement is per Lump Sum (LS).

B. Payment covers the complete installation and removal of any and all structures required to minimize environmental impact and non-point source pollution. Work includes, but is not limited to: purchasing and delivery of all materials; delays; installation of temporary work; maintaining and replacing work; removal of work and restoration of the site; and any and all incidentals.

Bid Item No. 5

CARE OF WATER (COW) PRACTICES

A. Measured is per Lump Sum (LS)

B. Payment covers complete cost of installation of structures and maintenance in place, to minimize environmental impacts and simultaneously maximize construction efficiency, by caring for water for the duration of the project. Work includes installation of turbidity curtains, coffer dams, oil booms, pumps and filters, coffer dams, sequencing, and intermittent excavation operations if exceeding 10 NTUs of turbidity, and all BMPs necessary for open bank excavations and channel work in the wet, and Care of Water permit conditions adherence. Payment covers methods, precautions, delays, installations, modifications, maintenance, replacement, and materials for water control structures and removal and disposal of structures and incidentals required to complete work as shown on drawings or noted in specifications.

Bid Item No. 6

HAUL ROUTE MAINTENANCE

A. Measurement is per Lump Sum (LS)

B. Payment covers the complete installation and removal of any and all activities required to establish, maintain, and restore haul routes during and after construction. Haul routes are expected to be minimal given the current state of the site, so all areas within project limits is available to hauling. Work includes, but is not limited to: purchasing and delivery of all materials; delays; installation of temporary work; maintaining and replacing work; removal of work and restoration of the site; and any and all incidentals.

Bid Item No. 7

CLEARING AND GRUBBING

A. Measurement is per Lump Sum (LS).

B. Meet or Exceed CDOT 2011 Standard Specification section 201

Bid Item No. 8, 19

EXCAVATION AND TRANSPORT TO DISPOSAL AREA

- A. Measurement per Cubic Yard (CY) of excavation
- B. Payment covers complete cost of the excavation and the transport to on site disposal areas. Work includes, but is not limited to: COW BMP's; supplying equipment; excavating; on-site transport; and any and all incidentals.

Bid Item No. 9

DISPOSAL AREA ROUGH GRADING

- A. Measurement per Cubic Yard (CY) of fill material
- B. Payment covers all work necessary to grade the disposal area fill to sub-grade elevations specified in plans (by others). Work includes, but is not limited to: BMP's; supplying equipment; rough grading; and any and all incidentals.

Bid Item No. 10

SELECTIVE SORTING AND STOCKPILING OF ALLUVIUM

- A. Measurement per Cubic Yard (CY) of alluvium
- B. Payment covers all work necessary to sort excavated material into gradations specified in section 4 of this document. Work includes, but is not limited to: BMP's; supplying equipment; sorting alluvium; and any and all incidentals.

Bid Item No. 11

GRADING OF RIFFLES WITH COARSE COBBLE ALLUVIUM

- A. Measurement per Cubic Yard (CY) of coarse cobble alluvium
- B. Payment covers all work necessary to grade sorted alluvium to elevations specified on plans and per section 2 of the technical specifications. Work includes, but is not limited to: COW BMP's; supplying equipment; fine grading; and any and all incidentals.

Bid Item No. 12, 20

FURNISH AND PLACE 36" BOULDER

- A. Measurement is per Ton of installed boulders per certified scale tickets.
- B. Sources of boulder must be approved by OWNER prior to procurement installation and payment.
- C. Boulder gradation must comply with section 4 of the technical specification.
- D. Payment covers complete cost of furnishing and installing boulders for the inlet structure, existing slough plug structure, or the junction with the existing slough per the plans and under the direction of the OWNER. Work includes, but is not limited to: COW BMP's; purchase and delivery of all materials; excavating; surveying; protecting filter fabric with alluvium; and any and all incidentals.

Bid Item No. 13, 22

BACKFILL BOULDER WITH GENERAL ALLUVIUM

- A. Measurement per Cubic Yard (CY) of general alluvium
- B. Payment covers all work necessary to backfill excavation of boulder structures and fill voids with general alluvium meeting gradations specified in section 4 of the technical specification.

Work includes, but is not limited to: BMP's; supplying equipment; backfilling; and any and all incidentals.

Bid Item No. 14

MITER, HAUL OFF, AND DISPOSE OF 30" STORM PIPE

A. Measurement per Linear Feet (LF) of storm pipe

B. Payment covers all work necessary to remove section of plastic storm pipe between the proposed slough and the Colorado River. Work includes, but is not limited to: BMP's; supplying equipment; excavating around pipe; removal of pipe; removal of associated structures; haul off and disposal; backfilling excavation; restoring impact area; mitering the pipe to conform with final grade; and any and all incidentals.

Bid Item No. 15

FURNISH AND INSTALL OUTFALL STRUCTURE FOR 30" STORM PIPE

A. Measurement per Cubic Yard (CY) of riprap

B. Payment covers all work necessary to furnish and install rip-rap outfall structure. Work includes, but is not limited to: BMP's; supplying equipment; installing riprap; and any and all incidentals.

Bid Items No. 16, 21

FURNISH AND INSTALL NON-WOVEN FILTER FABRIC BENEATH BOULDER/RIPRAP

A. Measurement is per square yard (SY) of installed non-woven filter fabric installed between the bank and boulders/riprap. Embedded lengths of erosion control fabrics, vertical faces, and overlapped fabric shall not be measured for payment.

B. Payment covers the complete cost of installing non-woven filter fabric. Work includes, but is not limited to: BMP's; providing all necessary good quality materials; labor; fasteners; excavation; installation per manufacturers recommendations; and any and all incidentals such as overlap at edges and tucking into bank; storing, and protecting fabric from tears or damage throughout construction.

Bid Item No. 17

DECONSTRUCT CONCRETE PATH

A. Measurement per Linear Feet (CY) of concrete

B. Payment covers all work necessary to deconstruct approximately 1,300 feet of existing concrete path on site. Work includes, but is not limited to: BMP's; supplying equipment; breaking up concrete; and any and all incidentals.

Bid Item No. 18

TRANSPORT/PLACE CONCRETE TO DISPOSAL AREA

A. Measurement per Linear Feet (CY) of concrete

B. Payment covers all work necessary to transport concrete from deconstructed path to disposal area on west side of site. Work includes, but is not limited to: BMP's; supplying equipment; loading and transporting concrete; placing concrete rubble at base of disposal area; and any and all incidentals.

Bid Item No. 23

FURNISH AND INSTALL WETLAND NATIVE SEED MIX

A. Measurement is per acre of seeded area

B. Payment covers the complete installation of wetland seed mix in locations specified on plans, and on those lands incidentally disturbed by construction activities. Work includes, but is not limited to: BMP's; purchasing all materials; broadcasting seed mix; raking into soil; special guarantees, any and all incidentals such as providing water necessary for establishment.

Bid Item No. 24

FURNISH AND INSTALL RIPARIAN NATIVE SEED MIX

A. Measurement is per acre of seeded area

B. Payment covers the complete installation of riparian seed mix in locations specified on plans, and on those lands incidentally disturbed by construction activities. Work includes, but is not limited to: BMP's; purchasing all materials; broadcasting seed mix; raking into soil; special guarantees, any and all incidentals such as providing water necessary for establishment.

Bid Items No. 25

FURNISH AND INSTALL DORMANT WILLOW POLES

A. Measurement is per square yard (SY) of installed bank surface.

B. Payment covers the complete cost of installing willow stakes along the banks of the proposed slough as specified on plans and marked by the ENGINEER in the field. Work includes, but is not limited to: BMP's; gathering stakes; keeping stakes alive; special guarantees; survival density warranties; and any and all incidentals such as re-mobilization associated with seasonal constraints.

Bid Items No. 26

EROSION CONTROL BLANKETS

A. Measurement is per square yard (SY) of installed erosion control blanket surface. Embedded lengths of erosion control fabrics, vertical faces, and overlapped fabric shall not be measured for payment.

B. Payment covers the complete cost of installing erosion control blankets. Work includes, but is not limited to: BMP's; providing all necessary good quality materials; labor; installation; and any and all incidentals such as key downs at edges and stakes; differing fabrics and installations for appropriate application. Seeding is covered in Bid Item 44 and 45.

Bid Item No. 27

TOP SOIL IMPORT AND GRADING

A. Measurement is per Cubic Yard (CY) of imported weed free top soil per certified scale tickets.

B. Payment covers costs of purchasing all materials; delivery and stockpile of top soil, including BMP's, grading in 4" min. lifts, preparation for erosion control fabrics, weed control and placement of top soil.