



Purchasing Division

Invitation for Bid

IFB-4534-18-DH
Persigo Wastewater Treatment Plant
Diffuser Outfall Improvements Project (RE-BID)

Responses Due:

June 5, 2018 prior to 3:30 pm MDT

Accepting Electronic Responses Only

Responses Only Submitted Through the Rocky Mountain E-Purchasing System (RMEPS)

<https://www.rockymountainbidsystem.com/default.asp>

(Purchasing Representative does not have access or control of the vendor side of RMEPS. If website or other problems arise during response submission, vendor **MUST** contact RMEPS to resolve issue prior to the response deadline. 800-835-4603)

Purchasing Representative:

Duane Hoff, Senior Buyer

duaneh@gjcity.org

(970)244-1545

This document has been developed specifically to solicit competitive responses for this solicitation, and may not be the same as previous City of Grand Junction solicitations. All vendors are urged to thoroughly review this solicitation prior to responding. Submittal by **FAX, EMAIL or HARD COPY IS NOT ACCEPTABLE** for this solicitation.

Invitation for Bids

Table of Contents

Section 1	Instruction to Bidders
Section 2	General Contract Conditions
Section 3	Statement of Work and Special Conditions
Section 4	Contractor's Bid Form Price Proposal/Bid Schedule Form
Appendix A	Project Submittal Form
Appendix B	Construction Specifications (By Stantec) <ul style="list-style-type: none">• Soils Report• Specifications• U.S. Army Corps Nationwide Permit 39 (SPK-2016-00171)
Appendix C	CDPHE's Construction Dewatering Permit (APPLICATION ONLY)
Appendix D	USGS Colorado River flows – Daily Average River Flows
Appendix E	Persigo WWTP Historical Effluent Flows Construction Drawings Attached (by Stantec)

1. Instructions to Bidders

- 1.1. **Purpose:** The City of Grand Junction is soliciting competitive bids from qualified and interested companies for all labor, equipment, and materials required for the **Persigo WWTP – Diffuser Outfall Improvements Project**. All dimensions and scope of work should be verified by Contractors prior to submission of bids.

IFB Questions:

Duane Hoff, Senior Buyer

970-244-1545

duaneh@gjcity.org

- 1.2. **Mandatory Pre-Bid Meeting:** **Prospective bidders are required to attend the mandatory pre-bid meeting on May 23, 2018 at 10:30 am.** Meeting location will be at the Persigo Wastewater Treatment Plant in the Conference Room, located at 2145 River Road, Grand Junction, CO. This meeting also allows the Owner to know who is planning on submitting a bid for the project. The purpose of this visit will be to inspect and to clarify the contents of this Invitation for Bids (IFB).
- 1.3. **The Owner:** The Owner is the City of Grand Junction, Colorado and is referred to throughout this Solicitation. The term Owner means the Owner or his authorized representative.
- 1.4. **Submission:** **Each bid shall be submitted in electronic format only, and only through the Rocky Mountain E-Purchasing website (<https://www.rockymountainbidsystem.com/default.asp>).** *This site offers both “free” and “paying” registration options that allow for full access of the Owner’s documents and for electronic submission of proposals. (Note: “free” registration may take up to 24 hours to process. Please Plan accordingly.)* Please view our “**Electronic Vendor Registration Guide**” at <http://www.gjcity.org/business-and-economic-development/bids/> for details. (Purchasing Representative does not have access or control of the vendor side of RMEPS. If website or other problems arise during response submission, vendor **MUST** contact RMEPS to resolve issue prior to the response deadline. **800-835-4603**)
- 1.5. **Modification and Withdrawal of Bids Before Opening:** Bids may be modified or withdrawn by an appropriate document stating such, duly executed and submitted to the place where Bids are to be submitted at any time prior to Bid Opening.
- 1.6. **Printed Form for Price Bid:** All Price Bids must be made upon the Price Bid Schedule attached, and should give the amounts both in words and in figures, and must be signed and acknowledged by the bidder.

The Offeror shall specify a unit price in figures for each pay item for which a quantity is given and shall provide the products (in numbers) of the respective unit prices and quantities in the Extended Amount column. The total Bid price shall be equal to the sum of all extended amount prices. When an item in the Price Bid Schedule provides a choice to be made by the Offeror, Offeror's choice shall be indicated in accordance with the specifications for that particular item and thereafter no further choice shall be permitted.

Where the unit of a pay item is lump sum, the lump sum amount shall be shown in the "extended amount" column and included in the summation of the total Bid.

All blank spaces in the Price Bid Schedule must be properly filled out.

Bids by corporations must be executed in the corporate name by the president or vice president or other corporate office accompanied by evidence of authority to sign. The corporate address and state of incorporation shall be shown below the signature.

Bids by partnerships must be executed in the partnership name and signed by a partner whose title must appear under the signature and the official address of the partnership must be shown below the signature.

All names must be typed or printed below the signature.

The Offeror's Bid shall contain an acknowledgement of receipt of all Addenda, the numbers of which shall be filled in on the Contractor's Bid Form.

The contact information to which communications regarding the Bid are to be directed must be shown.

- 1.7. **Exclusions:** No oral, telephonic, emailed, or facsimile bid will be considered
- 1.8. **Contract Documents:** The complete IFB and bidder's response compose the Contract Documents. Copies of bid documents can be obtained from the City Purchasing website, <http://www.gjcity.org/BidOpenings.aspx>.
- 1.9. **Additional Documents:** The July 2010 edition of the "City Standard Contract Documents for Capital Improvements Construction", Plans, Specifications and other Bid Documents are available for review or download on the Engineering page within Manuals/Permits at www.gjcity.org. Electronic copies may be obtained on a CD format at the Department of Public Works and Utilities at City Hall.
- 1.10. **Definitions and Terms:** See Article I, Section 3 of the General Contract Conditions in the *Standard Contract Documents for Capital Improvements Construction*.
- 1.11. **Examination of Specifications:** Bidders shall thoroughly examine and be familiar with the project Statement of Work. The failure or omission of any Offeror to receive or examine any form, addendum, or other document shall in no way relieve any Offeror from any obligation with respect to his bid. The submission of a bid shall be taken as evidence of compliance with this section. Prior to submitting a bid, each Offeror shall, at a minimum:
 - a. Examine the *Contract Documents* thoroughly;
 - b. Visit the site to familiarize themselves with local conditions that may in any manner affect cost, progress, or performance of the Work;

- c. Become familiar with federal, state, and local laws, ordinances, rules, and regulations that may in any manner affect cost, progress or performance of the Work;
- d. Study and carefully correlate Bidder's observations with the *Contract Documents*, and;
- e. Notify the Engineer of all conflicts, errors, ambiguities or discrepancies in or among the *Contract Documents*

On request, the Owner will provide each Offeror access to the site to conduct such investigations and tests as each Bidder deems necessary for submission of a Bid. It shall be the Offeror's responsibility to make or obtain any additional examinations, investigations, explorations, tests and studies and obtain any additional information and data which pertain to the physical conditions (including without limitation, surface, subsurface and underground utilities) at or contiguous to the site or otherwise which may affect cost, progress or performance of the work and which the Offeror deems necessary to determine its Bid for performing the work in accordance with the time, price and other terms and conditions of the *Contract Documents*. Location of any excavation or boring made by Offeror shall be subject to prior approval of Owner and applicable agencies. Offeror shall fill all holes, restore all pavements to match the existing structural section and shall clean up and restore the site to its former condition upon completion of such exploration. The Owner reserves the right to require the Offeror to execute an access agreement with the Owner prior to accessing the site.

The lands upon which the Work is to be performed, rights of way, and access thereto, and other lands designated for use by Contractor in performing the Work, are identified on the Drawings.

Information and data reflected in the *Contract Documents* with respect to underground utilities at or contiguous to the site are based upon information and data furnished to the Owner and the Engineer by the owners of such underground utilities or others, and the Owner does not assume responsibility for the accuracy or completeness thereof, unless it is expressly provided otherwise in the *Contract Documents*.

By submission of a Bid, the Offeror shall be conclusively presumed to represent that the Offeror has complied with every requirement of these Instructions to Bidders, that the *Contract Documents* are not ambiguous and are sufficient in scope and detail to indicate and convey understanding of all terms and conditions for performance of the Work.

1.12. Questions Regarding Statement of Work: Any information relative to interpretation of Scope of Work or specifications shall be requested of the Purchasing Representative, in writing, in ample time prior to the response time.

1.13. Addenda & Interpretations: If it becomes necessary to revise any part of this solicitation, a written addendum will be posted electronically on the City's website at <http://www.gjcity.org/business-and-economic-development/bids/>. The Owner is not bound by any oral representations, clarifications, or changes made in the written

specifications by Owner, unless such clarification or change is provided in written addendum form from the City Purchasing Representative.

- 1.14. **Taxes:** The Owner is exempt from State retail and Federal tax. The bid price must be net, exclusive of taxes.
- 1.15. **Sales and Use Taxes:** The Contractor and all Subcontractors are required to obtain exemption certificates from the Colorado Department of Revenue for sales and use taxes in accordance with the provisions of the General Contract Conditions. Bids shall reflect this method of accounting for sales and use taxes on materials, fixtures and equipment.
- 1.16. **Offers Binding 60 Days:** Unless additional time is required by the Owner, or otherwise specified, all formal offers submitted shall be binding for sixty (60) calendar days following opening date, unless the Bidder, upon request of the Purchasing Representative, agrees to an extension.
- 1.17. **Collusion Clause:** Each bidder by submitting a bid certifies that it is not party to any collusive action or any action that may be in violation of the Sherman Antitrust Act. Any and all bids shall be rejected if there is evidence or reason for believing that collusion exists among bidders. The Owner may, or may not, accept future bids for the same services or commodities from participants in such collusion.
- 1.18. **Disqualification of Bidders:** A Bid will not be accepted from, nor shall a Contract be awarded to, any person, firm, or corporation that is in arrears to the Owner, upon debt or contract, or that has defaulted, as surety or otherwise, upon any obligation to the Owner, or that is deemed irresponsible or unreliable.

Bidders may be required to submit satisfactory evidence that they are responsible, have a practical knowledge of the project bid upon and that they have the necessary financial and other resources to complete the proposed Work.

Either of the following reasons, without limitation, shall be considered sufficient to disqualify a Bidder and Bid:

- a. More than one Bid is submitted for the same Work from an individual, firm, or corporation under the same or different name; and
 - b. Evidence of collusion among Bidders. Any participant in such collusion shall not receive recognition as a Bidder for any future work of the Owner until such participant has been reinstated as a qualified bidder.
- 1.19. **Public Disclosure Record:** If the bidder has knowledge of their employee(s) or sub-contractors having an immediate family relationship with a City/County employee or elected official, the bidder must provide the Purchasing Representative with the name(s) of these individuals. These individuals are required to file an acceptable "Public Disclosure Record", a statement of financial interest, before conducting business with the City/County.

2. General Contract Conditions for Construction Projects

- 2.1. The Contract:** This Invitation for Bid, submitted documents, and any negotiations, when properly accepted by the City/County, shall constitute a contract equally binding between the City/County and Contractor. The contract represents the entire and integrated agreement between the parties hereto and supersedes all prior negotiations, representations, or agreements, either written or oral. The contract may be amended or modified with Change Orders, Field Orders, or Addendums.
- 2.2. The Work:** The term Work includes all labor necessary to produce the construction required by the Contract Documents, and all materials and equipment incorporated or to be incorporated in such construction.
- 2.3. Execution, Correlation, Intent, and Interpretations:** The Contract Documents shall be signed in not less than triplicate by the Owner (City/County) and Contractor. City/County will provide the contract. By executing the contract, the Contractor represents that he/she has visited the site, familiarized himself with the local conditions under which the Work is to be performed, and correlated his observations with the requirements of the Contract Documents. The Contract Documents are complementary, and what is required by any one, shall be as binding as if required by all. The intention of the documents is to include all labor, materials, equipment and other items necessary for the proper execution and completion of the scope of work as defined in the technical specifications and drawings contained herein. All drawings, specifications and copies furnished by the City/County are, and shall remain, City/County property. They are not to be used on any other project, and with the exception of one contract set for each party to the contract, are to be returned to the owner on request at the completion of the work.
- 2.4. The Owner:** The Owner is the City of Grand Junction and/or Mesa County, Colorado and is referred to throughout the Contract Documents. The term Owner means the Owner or his authorized representative. The Owner shall, at all times, have access to the work wherever it is in preparation and progress. The Contractor shall provide facilities for such access. The Owner will make periodic visits to the site to familiarize himself generally with the progress and quality of work and to determine, in general, if the work is proceeding in accordance with the contract documents. Based on such observations and the Contractor's Application for Payment, the Owner will determine the amounts owing to the Contractor and will issue Certificates for Payment in such amounts, as provided in the contract. The Owner will have authority to reject work which does not conform to the Contract documents. Whenever, in his reasonable opinion, he considers it necessary or advisable to insure the proper implementation of the intent of the Contract Documents, he will have authority to require the Contractor to stop the work or any portion, or to require special inspection or testing of the work, whether or not such work can be then be fabricated, installed, or completed. The Owner will not be responsible for the acts or omissions of the Contractor, and sub-Contractor, or any of their agents or employees, or any other persons performing any of the work.
- 2.5. Contractor:** The Contractor is the person or organization identified as such in the Agreement and is referred to throughout the Contract Documents. The term Contractor means the Contractor or his authorized representative. The Contractor shall carefully

study and compare the General Contract Conditions of the Contract, Specification and Drawings, Scope of Work, Addenda and Modifications and shall at once report to the Owner any error, inconsistency or omission he may discover. Contractor shall not be liable to the Owner for any damage resulting from such errors, inconsistencies or omissions. The Contractor shall not commence work without clarifying Drawings, Specifications, or Interpretations.

- 2.6. Sub-Contractors:** A sub-contractor is a person or organization who has a direct contract with the Contractor to perform any of the work at the site. The term sub-contractor is referred to throughout the contract documents and means a sub-contractor or his authorized representative.
- 2.7. Award of Sub-Contractors & Other Contracts for Portions of the Work:** Contractor shall submit with their bid response to the Owner, in writing for acceptance, a list of the names of the sub-contractors or other persons or organizations proposed for such portions of the work as may be designated in the proposal requirements, or, if none is so designated, the names of the sub-contractors proposed for the principal portions of the work. Prior to the award of the contract, the Owner shall notify the successful Contractor in writing if, after due investigation, has reasonable objection to any person or organization on such list. If, prior to the award of the contract, the Owner has a reasonable and substantial objection to any person or organization on such list, and refuses in writing to accept such person or organization, the successful Contractor may, prior to the award, withdraw their proposal without forfeiture of proposal security. If the successful Contractor submits an acceptable substitute with an increase in the proposed price to cover the difference in cost occasioned by the substitution, the Owner may, at their discretion, accept the increased proposal or may disqualify the Contractor. If, after the award, the Owner refuses to accept any person or organization on such list, the Contractor shall submit an acceptable substitute and the contract sum shall be increased or decreased by the difference in cost occasioned by such substitution and an appropriate Change Order shall be issued. However, no increase in the contract sum shall be allowed for any such substitution unless the Contractor has acted promptly and responsively in submitting a name with respect thereto prior to the award.
- 2.8. Quantities of Work and Unit Price:** Materials or quantities stated as unit price items in the Bid are supplied only to give an indication of the general scope of the Work, and are as such, estimates only. The Owner does not expressly or by implication agree that the actual amount of Work or material will correspond therewith, and reserves the right after award to increase or decrease the quantity of any unit item of the Work without a change in the unit price except as set forth in Article VIII, Section 70 of the *General Contract Conditions*. The City also reserves the right to make changes in the Work (including the right to delete any bid item in its entirety or add additional bid items) as set forth in Article VIII, Sections 69 through 71 of the *General Contract Conditions*.
- 2.9. Substitutions:** The materials, products and equipment described in the *Solicitation Documents* shall be regarded as establishing a standard of required performance, function, dimension, appearance, or quality to be met by any proposed substitution. No substitution will be considered prior to receipt of Bids unless the Offeror submits a written request for approval to the City Purchasing Division at least ten (10) days prior to the date for receipt of Bids. Such requests for approval shall include the name of the material

or equipment for which substitution is sought and a complete description of the proposed substitution including drawings, performance and test data, and other information necessary for evaluation, including samples if requested. The Offeror shall set forth changes in other materials, equipment, or other portions of the Work including changes of the work of other contracts, which incorporation of the proposed substitution would require to be included. The Owner's decision of approval or disapproval of a proposed substitution shall be final. If the Owner approves a proposed substitution before receipt of Bids, such approval will be set forth in an Addendum. Offerors shall not rely upon approvals made in any other manner.

- 2.10. Supervision and Construction Procedures:** The Contractor shall supervise and direct the work, using his best skill and attention. He shall be solely responsible for all construction means, methods, techniques, sequences and procedures and for coordinating all portions of the work under the contract.
- 2.11. Warranty:** The Contractor warrants to the Owner that all materials and equipment furnished under this contract will be new unless otherwise specified, and that all work will be of good quality, free from faults and defects and in conformance with the Contract Documents. All work not so conforming to these standards may be considered defective. If required by Owner, the Contractor shall furnish satisfactory evidence as to the kind and quality of materials and equipment. If within ten (10) days after written notice to the Contractor requesting such repairs or replacement, the Contractor should neglect to make or undertake with due diligence to the same, the City may make such repairs or replacements. All indirect and direct costs of such correction or removal or replacement shall be at the Contractor's expense. The Contractor will also bear the expenses of making good all work of others destroyed or damaged by the correction, removal or replacement of his defective work.
- 2.12. Permits, Fees, & Notices:** The Contractor shall secure and pay for all permits, governmental fees and licenses necessary for the proper execution and completion of the work. The Contractor shall give all notices and comply with all laws, ordinances, rules, regulations and orders of any public authority bearing on the performance of the work. If the Contractor observes that any of the Contract Documents are at variance in any respect, he shall promptly notify the Owner in writing, and any necessary changes shall be adjusted by approximate modification. If the Contractor performs any work knowing it to be contrary to such laws, ordinances, rules and regulations, and without such notice to the Owner, he shall assume full responsibility and shall bear all costs attributable.
- 2.13. Responsibility for Those Performing the Work:** The Contractor shall be responsible to the Owner for the acts and omissions of all his employees and all sub-contractors, their agents and employees, and all other persons performing any of the work under a contract with the Contractor.
- 2.14. Use of the Site:** The Contractor shall confine operations at the site to areas permitted by law, ordinances, permits and the Contract Documents, and shall not unreasonably encumber the site with any materials or equipment.

2.15. Cleanup: The Contractor at all times shall keep the premises free from accumulation of waste materials or rubbish caused by his operations. At the completion of work he shall remove all his waste materials and rubbish from and about the project, as well as all his tools, construction equipment, machinery and surplus materials.

2.16. Insurance: The Contractor shall secure and maintain such insurance policies as will provide the coverage and contain other provisions specified in the General Contract Conditions, or as modified in the Special Contract Conditions.

The Contractor shall file a copy of the policies or Certificates of Insurance acceptable to the City with the Engineer within ten (10) Calendar Days after issuance of the Notice of Award. These Certificates of Insurance shall contain a provision that coverage afforded under the policies shall not be canceled unless at least thirty (30) Calendar Days prior written notice has been given to the City.

2.17. Indemnification: The Contractor shall defend, indemnify and save harmless the Owner, and all its officers, employees, insurers, and self-insurance pool, from and against all liability, suits, actions, or other claims of any character, name and description brought for or on account of any injuries or damages received or sustained by any person, persons, or property on account of any negligent act or fault of the Contractor, or of any Contractor's agent, employee, sub-contractor or supplier in the execution of, or performance under, any contract which may result from proposal award. Contractor shall pay any judgment with cost which may be obtained against the Owner growing out of such injury or damages.

2.18. Miscellaneous Conditions: Material Availability: Contractors must accept responsibility for verification of material availability, production schedules, and other pertinent data prior to submission of bid. It is the responsibility of the bidder to notify the Owner immediately if materials specified are discontinued, replaced, or not available for an extended period of time. OSHA Standards: All bidders agree and warrant that services performed in response to this invitation shall conform to the standards declared by the US Department of Labor under the Occupational Safety and Health Act of 1970 (OSHA). In the event the services do not conform to OSHA standards, the Owner may require the services to be redone at no additional expense to the Owner.

2.19. Time: Time is of the essence with respect to the time of completion of the Project and any other milestones or deadline which are part of the Contract. It will be necessary for each Bidder to satisfy the City of its ability to complete the Work within the Contract Time set forth in the Contract Documents. The Contract Time is the period of time allotted in the Contract Documents for completion of the work. The date of commencement of the work is the date established in a Notice to Proceed. If there is no Notice to Proceed, it shall be the date of the Contract or such other date as may be established therein, or as established as entered on the Bid Form. The Date of Substantial Completion of the work or designated portions thereof is the date certified by the Owner when construction is sufficiently complete, in accordance with the Contract Documents.

2.20. Progress & Completion: The Contractor shall begin work on the date of commencement as defined in the Contract, and shall carry the work forward expeditiously with adequate forces and shall complete it within the contract time.

2.21. Payment & Completion: The Contract Sum is stated in the Contract and is the total amount payable by the Owner to the Contractor for the performance of the work under the Contract Documents. Upon receipt of written notice that the work is ready for final inspection and acceptance and upon receipt of application for payment, the Owner's Project Manager will promptly make such inspection and, when he finds the work acceptable under the Contract Documents and the Contract fully performed, the Owner shall make payment in the manner provided in the Contract Documents.

2.22. Bid Bond: Each Bid shall as a guaranty of good faith on the part of the Bidder be accompanied by a Bid Guaranty consisting of: a certified or cashier's check drawn on an approved national bank or trust company in the state of Colorado, and made payable without condition to the City; or a **Bid Bond** written by an approved corporate surety in favor of the City. The amount of the Bid Guaranty shall not be less than 5% of the total Bid amount. Once a Bid is accepted and a Contract is awarded, the apparent successful bidder has ten calendar days to enter into a contract in the form prescribed and to furnish the bonds with a legally responsible and approved surety. Failure to do so will result in forfeiture of the Bid Guaranty to the City as Liquidated Damages.

Each bidder shall guaranty its total bid price for a period of sixty (60) Calendar Days from the date of the bid opening.

2.23. Performance & Payment Bonds: Contractor shall furnish a Performance and a Payment Bond, each in an amount at least equal to that specified for the contract amount as security for the faithful performance and payment of all Contractor's obligations under the Contract Documents. These bonds shall remain in effect for the duration of the Warranty Period (as specified in the Special Conditions). Contractor shall also furnish other bonds that may be required by the Special Conditions. All bonds shall be in the forms prescribed by the Contract Documents and be executed by such sureties as (1) are licensed to conduct business in the State of Colorado and (2) are named in the current list of "Companies Holding Certificates of Authority as Acceptable Sureties on Federal Bonds and as Acceptable Reinsuring Companies" as published in Circular 570 (amended) by the Audit Staff, Bureau of Accounts, U.S. Treasury Department. All bonds signed by an agent must be accompanied by a certified copy of the Authority Act. If the surety on any bond furnished by the Contractor is declared bankrupt, or becomes insolvent, or its rights to do business in Colorado are terminated, or it ceases to meet the requirements of clauses (1) and (2) of this section, Contractor shall within five (5) days thereafter substitute another bond and surety, both of which shall be acceptable to the City.

2.24. Retention: The Owner will deduct money from the partial payments in amounts considered necessary to protect the interest of the Owner and will retain this money until after completion of the entire contract. The amount to be retained from partial payments will be five (5) percent of the value of the completed work, and not greater than five (5) percent of the amount of the Contract. When the retainage has reached five (5) percent of the amount of the Contract no further retainage will be made and this amount will be retained until such time as final payment is made.

2.25. Liquidated Damages for Failure to Enter Into Contract: (CITY ONLY) Should the Successful Bidder fail or refuse to enter into the Contract within ten Calendar Days from the issuance of the Notice of Award, the City shall be entitled to collect the amount of such Bidder's Bid Guaranty as Liquidated Damages, not as a penalty but in consideration of the mutual release by the City and the Successful Bidder of all claims arising from the City's issuance of the Notice of Award and the Successful Bidder's failure to enter into the Contract and the costs to award the Contract to any other Bidder, to re-advertise, or otherwise dispose of the Work as the City may determine best serves its interest.

2.26. Liquidated Damages for Failure to Meet Project Completion Schedule: (CITY ONLY) If the Contractor does not achieve Final Completion by the required date, whether by neglect, refusal or any other reason, the parties agree and stipulate that the Contractor shall pay liquidated damages to the City for each such day that final completion is late. As provided elsewhere, this provision does not apply for delays caused by the City. The date for Final Completion may be extended in writing by the Owner.

The Contractor agrees that as a part of the consideration for the City's awarding of this Contract liquidated damages in the daily amount of **\$350.00** is reasonable and necessary to pay for the actual damages resulting from such delay. The parties agree that the real costs and injury to the City for such delay include hard to quantify items such as: additional engineering, inspection and oversight by the City and its agents; additional contract administration; inability to apply the efforts of those employees to the other work of the City; perceived inefficiency of the City; citizens having to deal with the construction and the Work, rather than having the benefit of a completed Work, on time; inconvenience to the public; loss of reputation and community standing for the City during times when such things are very important and very difficult to maintain.

The Contractor must complete the Work and achieve final completion included under the Bid Schedule in the number of consecutive calendar days after the City gives its written Notice to Proceed. When the Contractor considers the entire Work ready for its intended use, Contractor shall certify in writing that the Work is substantially complete. In addition to the Work being substantially complete, Final Completion date is the date by which the Contractor shall have fully completed all clean-up, and all items that were identified by the City in the inspection for final completion. Unless otherwise stated in the Special Conditions, for purposes of this liquidated damages clause, the Work shall not be finished and the Contract time shall continue to accrue until the City gives its written Final Acceptance.

If the Contractor shall fail to pay said liquidated damages promptly upon demand thereof after having failed to achieve Final Completion on time, the City shall first look to any retainage or other funds from which to pay said liquidated damages; if retainage or other liquid funds are not available to pay said liquidated damages amounts, the Surety on the Contractor's Performance Bond and Payment Bond shall pay such liquidated damages. In addition, the City may withhold all, or any part of, such liquidated damages from any payment otherwise due the Contractor.

Liquidated damages as provided do not include any sums to reimburse the City for extra costs which the City may become obligated to pay on other contracts which were delayed or extended because of the Contractor's failure to complete the Work within the Contract

Time. Should the City incur additional costs because of delays or extensions to other contracts resulting from the Contractor's failure of timely performance, the Contractor agrees to pay these costs that the City incurs because of the Contractor's delay, and these payments are separate from and in addition to any liquidated damages.

The Contractor agrees that the City may use its own forces or hire other parties to obtain Substantial or Final Completion of the work if the time of completion has elapsed and the Contractor is not diligently pursuing completion. In addition to the Liquidated Damages provided for, the Contractor agrees to reimburse the City for all expenses thus incurred.

- 2.27. Contingency/Force Account:** Contingency/Force Account work will be authorized by the Owner's Project Manager and is defined as minor expenses to cover miscellaneous or unforeseen expenses related to the project. The expenses are not included in the Drawings, Specifications, or Scope of Work and are necessary to accomplish the scope of this contract. Contingency/Force Account Authorization will be directed by the Owner through an approved form. Contingency/Force Account funds are the property of the Owner and any Contingency/Force Account funds, not required for project completion, shall remain the property of the Owner. Contractor is not entitled to any Contingency/Force Account funds, that are not authorized by Owner or Owner's Project Manager.
- 2.28. Protection of Persons & Property:** The Contractor shall comply with all applicable laws, ordinances, rules, regulations and orders of any public authority having jurisdiction for the safety of persons or property or to protect them from damage, injury or loss. Contractor shall erect and maintain, as required by existing safeguards for safety and protection, and all reasonable precautions, including posting danger signs or other warnings against hazards promulgating safety regulations and notifying owners and users of adjacent utilities. When or where any direct or indirect damage or injury is done to public or private property by or on account of any act, omission, neglect, or misconduct by the Contractor in the execution of the work, or in consequence of the non-execution thereof by the Contractor, he shall restore, at his own expense, such property to a condition similar or equal to that existing before such damage or injury was done, by repairing, rebuilding, or otherwise restoring as may be directed, or it shall make good such damage or injury in an acceptable manner.
- 2.29. Changes in the Work:** The Owner, without invalidating the contract, may order changes in the work within the general scope of the contract consisting of additions, deletions or other revisions, the contract sum and the contract time being adjusted accordingly. All such changes in the work shall be authorized by Change Order and shall be executed under the applicable conditions of the contract documents. A Change Order is a written order to the Contractor signed by the Owner issued after the execution of the contract, authorizing a change in the work or an adjustment in the contract sum or the contract time. The contract sum and the contract time may be changed only by Change Order.
- 2.30. Claims for Additional Cost or Time:** If the Contractor wishes to make a claim for an increase in the contract sum or an extension in the contract time, he shall give the Owner written notice thereof within a reasonable time after the occurrence of the event giving rise to such claim. This notice shall be given by the Contractor before proceeding to execute the work, except in an emergency endangering life or property in which case the

Contractor shall precede in accordance with the regulations on safety. No such claim shall be valid unless so made. Any change in the contract sum or contract time resulting from such claim shall be authorized by Change Order.

- 2.31. Minor Changes in the Work:** The Owner shall have authority to order minor changes in the work not involving an adjustment in the contract sum or an extension of the contract time and not inconsistent with the intent of the contract documents.
- 2.32. Field Orders:** The Owner may issue written Field Orders which interpret the Contract Documents in accordance with the specifications, or which order minor changes in the work in accordance with the agreement, without change in the contract sum or time. The Contractor shall carry out such Field Orders promptly.
- 2.33. Uncovering & Correction of Work:** The Contractor shall promptly correct all work rejected by the Owner as defective or as failing to conform to the contract documents whether observed before or after substantial completion and whether or not fabricated installed or competed. The Contractor shall bear all costs of correcting such rejected work, including the cost of the Owner's additional services thereby made necessary. If within one (1) year after the date of completion or within such longer period of time as may be prescribed by law or by the terms of any applicable special guarantee required by the contract documents, any of the work found to be defective or not in accordance with the contract documents, the Contractor shall correct it promptly after receipt of a written notice from the Owner to do so unless the Owner has previously given the Contractor a written acceptance of such condition. The Owner shall give such notice promptly after discover of condition. All such defective or non-conforming work under the above paragraphs shall be removed from the site where necessary and the work shall be corrected to comply with the contract documents without cost to the Owner. The Contractor shall bear the cost of making good all work of separate Contractors destroyed or damaged by such removal or correction. If the Owner prefers to accept defective or non-conforming work, he may do so instead of requiring its removal and correction, in which case a Change Order will be issued to reflect an appropriate reduction in the payment or contract sum, or, if the amount is determined after final payment, it shall be paid by the Contractor.
- 2.30. Amendment:** No oral statement of any person shall modify or otherwise change, or affect the terms, conditions or specifications stated in the resulting contract. All amendments to the contract shall be made in writing by the Owner.
- 2.31. Assignment:** The Contractor shall not sell, assign, transfer or convey any contract resulting from this IFB, in whole or in part, without the prior written approval from the Owner.
- 2.32. Compliance with Laws:** Bids must comply with all Federal, State, County and local laws governing or covering this type of service and the fulfillment of all ADA (Americans with Disabilities Act) requirements.
- 2.33. Confidentiality:** All information disclosed by the Owner to the Contractor for the purpose of the work to be done or information that comes to the attention of the Contractor during the course of performing such work is to be kept strictly confidential.

- 2.34. Conflict of Interest:** No public official and/or City/County employee shall have interest in any contract resulting from this IFB.
- 2.35. Contract Termination:** This contract shall remain in effect until any of the following occurs: (1) contract expires; (2) completion of services; (3) acceptance of services or, (4) for convenience terminated by either party with a written *Notice of Cancellation* stating therein the reasons for such cancellation and the effective date of cancellation.
- 2.36. Employment Discrimination:** During the performance of any services per agreement with the Owner, the Contractor, by submitting a Bid, agrees to the following conditions:
- 2.36.1.** The Contractor shall not discriminate against any employee or applicant for employment because of race, religion, color, sex, age, handicap, or national origin except when such condition is a legitimate occupational qualification reasonably necessary for the normal operations of the Contractor. The Contractor agrees to post in conspicuous places, visible to employees and applicants for employment, notices setting forth the provisions of this nondiscrimination clause.
- 2.36.2.** The Contractor, in all solicitations or advertisements for employees placed by or on behalf of the Contractor, shall state that such Contractor is an Equal Opportunity Employer.
- 2.36.3.** Notices, advertisements, and solicitations placed in accordance with federal law, rule, or regulation shall be deemed sufficient for the purpose of meeting the requirements of this section.
- 2.37. Affirmative Action:** In executing a Contract with the City, the Contractor agrees to comply with Affirmative Action and Equal Employment Opportunity regulations presented in the General Contract Conditions.
- 2.38. Immigration Reform and Control Act of 1986 and Immigration Compliance:** The Offeror certifies that it does not and will not during the performance of the contract employ illegal alien workers or otherwise violate the provisions of the Federal Immigration Reform and Control Act of 1986 and/or the immigration compliance requirements of State of Colorado C.R.S. § 8-17.5-101, *et.seq.* (House Bill 06-1343).
- 2.39. Ethics:** The Contractor shall not accept or offer gifts or anything of value nor enter into any business arrangement with any employee, official, or agent of the Owner.
- 2.40. Failure to Deliver:** In the event of failure of the Contractor to deliver services in accordance with the contract terms and conditions, the Owner, after due oral or written notice, may procure the services from other sources and hold the Contractor responsible for any costs resulting in additional purchase and administrative services. This remedy shall be in addition to any other remedies that the Owner may have.
- 2.41. Failure to Enforce:** Failure by the Owner at any time to enforce the provisions of the contract shall not be construed as a waiver of any such provisions. Such failure to

enforce shall not affect the validity of the contract or any part thereof or the right of the Owner to enforce any provision at any time in accordance with its terms.

- 2.42. Force Majeure:** The Contractor shall not be held responsible for failure to perform the duties and responsibilities imposed by the contract due to legal strikes, fires, riots, rebellions, and acts of God beyond the control of the Contractor, unless otherwise specified in the contract.
- 2.43. Independent Contractor:** The Contractor shall be legally considered an Independent Contractor and neither the Contractor nor its employees shall, under any circumstances, be considered servants or agents of the Owner. The Owner shall be at no time legally responsible for any negligence or other wrongdoing by the Contractor, its servants, or agents. The Owner shall not withhold from the contract payments to the Contractor any federal or state unemployment taxes, federal or state income taxes, Social Security Tax or any other amounts for benefits to the Contractor. Further, the Owner shall not provide to the Contractor any insurance coverage or other benefits, including Workers' Compensation, normally provided by the Owner for its employees.
- 2.44. Nonconforming Terms and Conditions:** A bid that includes terms and conditions that do not conform to the terms and conditions of this Invitation for Bid is subject to rejection as non-responsive. The Owner reserves the right to permit the Contractor to withdraw nonconforming terms and conditions from its bid prior to a determination by the Owner of non-responsiveness based on the submission of nonconforming terms and conditions.

Items for non-responsiveness may include, but not be limited to:

- a. Submission of the Bid on forms other than those supplied by the City;
- b. Alteration, interlineation, erasure, or partial detachment of any part of the forms which are supplied herein;
- c. Inclusion of unauthorized additions conditional or alternate Bids or irregularities of any kind which may tend to make the Bid incomplete, indefinite, or ambiguous as to its meaning;
- d. Failure to acknowledge receipt of any or all issued Addenda;
- e. Failure to provide a unit price or a lump sum price, as appropriate, for each pay item listed except in the case of authorized alternative pay items;
- f. Failure to list the names of Subcontractors used in the Bid preparation as may be required in the Solicitation Documents;
- g. Submission of a Bid that, in the opinion of the Owner, is unbalanced so that each item does not reasonably carry its own proportion of cost or which contains inadequate or unreasonable prices for any item;
- h. Tying of the Bid with any other bid or contract; and

- i. Failure to calculate Bid prices as described herein.

2.45. Evaluation of Bids and Offerors: The Owner reserves the right to:

- reject any and all Bids,
- waive any and all informalities,
- negotiate final terms with the Successful Bidder, and
- disregard any and all nonconforming, nonresponsive or conditional Bids.

Discrepancies between words and figures will be resolved in favor of words. Discrepancies between Unit Prices and Extended Prices will be resolved in favor of the Unit Prices. Discrepancies between the indicated sum of any column of figures and the correct sum thereof will be resolved in favor of the correct sum. The corrected extensions and totals will be shown in the tabulation of Bids.

The Owner may consider the qualifications and experience of Subcontractors and other persons and organizations (including those who are to furnish the principal items of material or equipment) proposed for those portions of the work as to which the identity of Subcontractors and other persons and organizations must be submitted. Operating costs, maintenance considerations performance data, and guarantees of materials and equipment may also be considered by the Owner.

The Owner will conduct such investigations as deemed necessary to assist in the evaluation of any Bid and to establish the responsibility, qualifications and financial ability of the Offeror, proposed Subcontractors and other persons and organizations to do the Work in accordance with the *Contract Documents* to the City's satisfaction within the Contract Time.

The Offeror shall furnish the Owner all information and data requested by the Owner to determine the ability of the Offeror to perform the Work. The Owner reserves the right to reject the Bid if the evidence submitted by, or investigation of such Offeror fails to satisfy the Owner that such Offeror is properly qualified to carry out the obligations of the Contract and to complete the Work contemplated therein.

By submitting a Bid, each Offeror authorizes the Owner to perform such investigation of the Offeror as the Owner deems necessary to establish the responsibility, qualifications and financial ability of the Offeror and, by its signature thereon, authorizes the Owner to obtain reference information concerning the Offeror and releases the party providing such information and the Owner from any and all liability to the Offeror as a result of such reference information so provided.

The Owner reserves the right to reject the Bid of any Offeror who does not pass any evaluation to the Owner's satisfaction.

If the Contract is to be awarded, it will be awarded to the Offeror who, by evaluation, the Owner determines will best meet the Owner's interests.

The Owner reserves the right to accept or reject the Work contained in any of the Price Bid Schedules or alternates, either in whole or in part.

2.46. Award of Contract: Unless otherwise indicated, a single award will be made for all the bid items in an individual bid schedule. In the event that the Work is contained in more than one Bid Schedule, the City may award Schedules individually or in combination. In the case of two Bid Schedules which are alternative to each other, only one of such alternative Schedules will be awarded. Within forty-five (45) Calendar Days of Bid Opening, the City will issue a Notice of Award to the Successful Bidder which will be accompanied by four (4) unsigned copies of the Contract and the Performance and Payment Bond forms. Within ten (10) Calendar Days thereafter, the Successful Bidder shall sign and deliver four (4) copies of the Contract, Performance Bond, Payment Bond and Certificates of Insurance to the City. Within ten (10) Calendar Days thereafter, the City will deliver two (2) fully executed counterparts of the Contract to the Contractor. No contract shall exist between the Successful Bidder and the City and the Successful Bidder shall have no rights at law or in equity until the Contract has been duly executed by the City.

The Successful Bidder's failure to sign and submit a Contract and other documents set forth in this Paragraph within the prescribed time shall be just cause of annulment of the award, and forfeiture of the Bid Guaranty. The award of Contract may then be made to the next qualified Bidder in the same manner as previously prescribed.

2.47. Ownership: All plans, prints, designs, concepts, etc., shall become the property of the Owner.

2.48. Oral Statements: No oral statement of any person shall modify or otherwise affect the terms, conditions, or specifications stated in this document and/or resulting agreement. All modifications to this request and any agreement must be made in writing by the Owner.

2.49. Patents/Copyrights: The Contractor agrees to protect the Owner from any claims involving infringements of patents and/or copyrights. In no event shall the Owner be liable to the Contractor for any/all suits arising on the grounds of patent(s)/copyright(s) infringement. Patent/copyright infringement shall null and void any agreement resulting from response to this IFB.

2.50. Remedies: The Contractor and Owner agree that both parties have all rights, duties, and remedies available as stated in the Uniform Commercial Code.

2.51. Venue: Any agreement as a result of responding to this IFB shall be deemed to have been made in, and shall be construed and interpreted in accordance with, the laws of the City of Grand Junction, Mesa County, Colorado.

2.52. Expenses: Expenses incurred in preparation, submission and presentation of this IFB are the responsibility of the company and cannot be charged to the Owner.

2.53. Sovereign Immunity: The Owner specifically reserves its right to sovereign immunity pursuant to Colorado State Law as a defense to any action arising in conjunction to this agreement.

2.54. Non-Appropriation of Funds: The contractual obligation of the Owner under this contract is contingent upon the availability of appropriated funds from this fiscal year budget as approved by the City Council or Board of County Commissioners from this fiscal year only. State of Colorado Statutes prohibit obligation of public funds beyond the fiscal year for which the budget was approved. Anticipated expenditures/obligations beyond the end of the current Owner's fiscal year budget shall be subject to budget approval. Any contract will be subject to and must contain a governmental non-appropriation of funds clause.

2.55. Cooperative Purchasing: Purchases as a result of this solicitation are primarily for the City/County. Other governmental entities may be extended the opportunity to utilize the resultant contract award with the agreement of the successful provider and the participating agencies. All participating entities will be required to abide by the specifications, terms, conditions and pricings established in this Bid. The quantities furnished in this bid document are for only the City/County. It does not include quantities for any other jurisdiction. The City or County will be responsible only for the award for its jurisdiction. Other participating entities will place their own awards on their respective Purchase Orders through their purchasing office or use their purchasing card for purchase/payment as authorized or agreed upon between the provider and the individual entity. The City/County accepts no liability for payment of orders placed by other participating jurisdictions that choose to piggy-back on our solicitation. Orders placed by participating jurisdictions under the terms of this solicitation will indicate their specific delivery and invoicing instructions.

2.56. Keep Jobs in Colorado Act: Contractor shall be responsible for ensuring compliance with Article 17 of Title 8, Colorado Revised Statutes requiring 80% Colorado labor to be employed on public works. Contractor shall, upon reasonable notice provided by the Owner, permit the Owner to inspect documentation of identification and residency required by C.R.S. §8-17-101(2)(a). If Contractor claims it is entitled to a waiver pursuant to C.R.S. §8-17-101(1), Contractor shall state that there is insufficient Colorado labor to perform the work such that compliance with Article 17 would create an undue burden that would substantially prevent a project from proceeding to completion, and shall include evidence demonstrating the insufficiency and undue burden in its response.

Unless expressly granted a waiver by the Owner pursuant to C.R.S. §8-17-101(1), Contractor shall be responsible for ensuring compliance with Article 17 of Title 8, Colorado Revised Statutes requiring 80% Colorado labor to be employed on public works. Contractor shall, upon reasonable notice provided by the Owner, permit the Owner to inspect documentation of identification and residency required by C.R.S. §8-17-101(2)(a).

2.56.1. "Public project" is defined as:

- (a) any construction, alteration, repair, demolition, or improvement of any land, building, structure, facility, road, highway, bridge, or other public improvement suitable for and intended for use in the promotion of the public health, welfare, or safety and any maintenance programs for the upkeep of such projects

- (b) for which appropriate or expenditure of moneys may be reasonably expected to be \$500,000.00 or more in the aggregate for any fiscal year
- (c) except any project that receives federal moneys.

3. Statement of Work

3.1. GENERAL: The City of Grand Junction is soliciting competitive bids from qualified and interested companies for all labor, equipment, and materials required for the **Persigo WWTP – Diffuser Outfall Improvements Project**. All dimensions and scope of work should be verified by Contractors prior to submission of bids.

3.2. PROJECT DESCRIPTION: The Project generally includes approximately 2,000 linear feet of 48” RCP (or equivalent) and 54” HDPE, with a section requiring a 60” diameter bore under Interstate 70 (I-70), seven 90” diameter manholes, new concrete effluent box, removal and abandonment of the existing effluent outfall, native seeding, and a new 54” diameter HDPE diffuser outfall in the Colorado River.

3.3. SPECIAL CONDITIONS:

3.3.1 Mandatory Pre-Bid Meeting: Prospective bidders are required to attend the mandatory pre-bid meeting on May 23, 2018 at 10:30 am. Meeting location will be at the Persigo Wastewater Treatment Plant in the Conference Room, located at 2145 River Road, Grand Junction, CO. This meeting also allows the Owner to know who is planning on submitting a bid for the project. The purpose of this visit will be to inspect and to clarify the contents of this Invitation for Bids (IFB).

3.3.2 QUESTIONS REGARDING SOLICIATION PROCESS/SCOPE OF WORK:

Duane Hoff Jr., Senior Buyer
City of Grand Junction
duaneh@gjcity.org

3.3.3 Project Manager: The Project Manager for the Project is Lee Cooper, Project Engineer, who can be reached at (970) 256-4155. During Construction, all notices, letters, submittals, and other communications directed to the City shall be addressed and mailed or delivered to:

City of Grand Junction
Department of Public Works and Utilities
Attn: Lee Cooper, Project Engineer
2145 River Road
Grand Junction, CO 81505

3.3.4 Affirmative Action: The Contractor is not required to submit a written Affirmative Action Program for the Project.

3.3.5 Pricing: Pricing shall be all inclusive to include but not be limited to: all labor, equipment, supplies, materials, freight (F.O.B. Destination – Freight Pre-paid and Allowed to each site), travel, mobilization costs, fuel, set-up and take down costs, and full-time inspection costs, and all other costs related to the successful

completion of the project.

The Owner shall not pay nor be liable for any other additional costs including but not limited to: taxes, shipping charges, insurance, interest, penalties, termination payments, attorney fees, liquidated damages, etc.

3.3.6 Freight/Shipping: All freight/shipping shall be F.O.B. Destination – Freight Pre-Paid and Allowed to the project site(s), Grand Junction, CO.

3.3.7 Contractor must meet all federal, state, and local rules, regulations, and requirements for providing such services.

3.3.8 Contract: A binding contract shall consist of: (1) the IFB and any amendments thereto, (2) the bidder's response (bid) to the IFB, (3) clarification of the bid, if any, and (4) the City's Purchasing Department's acceptance of the bid by "Notice of Award" or by "Purchase Order". All Exhibits and Attachments included In the IFB shall be incorporated into the contract by reference.

A. The contract expresses the complete agreement of the parties and, performance shall be governed solely by the specifications and requirements contained therein.

B. Any change to the contract, whether by modification and/or supplementation, must be accomplished by a formal contract amendment signed and approved by and between the duly authorized representative of the bidder and the City Purchasing Division or by a modified Purchase Order prior to the effective date of such modification. The bidder expressly and explicitly understands and agrees that no other method and/or no other document, including acts and oral communications by or from any person, shall be used or construed as an amendment or modification to the contract.

3.3.9 Time of Completion: The scheduled time of Completion for the Project is **173 Calendar Days** from the starting date specified in the Notice to Proceed. City holidays recognized during this period of Labor Day (Sept. 3rd), Thanksgiving (Nov. 22nd), Christmas (Dec. 25th), New Year's (Jan. 1st), and Martin Luther King Jr. Day (Jan. 15th).

Completion is achieved when site cleanup and all punch list items (resulting from the final inspection) have been completed. Completion shall have the meaning set forth in Article I, Section 3 (Definitions and Terms) of the General Contract Conditions.

3.3.10 Working Days and Hours: The Contractor is permitted to work seven (7) days per week, up to 12 hours per day 6:00 am to 6:00 pm, (additional working hours available with City Project Engineer approval). The City will allow weekend work to happen during construction and installation of the diffuser structure and 60" casing pipe only. Other work hours and days may be allowed by the City upon 48 hours written notice.

Emergency work may be done without prior consent provided the Contractor notifies the Project Engineer prior to beginning the work.

3.3.11 Licenses and Permits: Contractor is responsible for obtaining all necessary licenses and permits required for Construction, at Contractors expense. See Section 2.12. Contractor shall supply to Owner all copies of finalized permits.

3.3.12 Permits: The following permits are required for the Project and will be obtained by the City at no cost to the Contractor:

- U.S. Army Corps Nationwide 404 Permit (*Received*)
- Colorado Dept. of Transportation (CDOT) Access/Utility Permit
- Colorado Dept. of Transportation (CDOT) Temporary Access Control Break License (*Received, Allows work within CDOT right-of-way*)
- Colorado Dept. of Public Health & Environment – *Construction Stormwater Discharge Permit* – Stormwater permit will be transferred to the Contractor after a construction contract has been fully executed.
- Colorado Dept. of Public Health & Environment – *Effluent Discharge Permit*

The following permits are required for the Project and shall be obtained and paid for by the Contractor, with the costs included in the total bid price for the Project:

- Colorado Dept. of Public Health & Environment – *Construction Dewatering Permit*

3.3.13 City Furnished Materials: The City will furnish the following materials for the Project:

- AutoCAD drawings for survey stakeout

3.3.14 Project Newsletters: Not applicable to Project.

3.3.15 Project Sign: Project signs, if any, will be furnished and installed by the City.

3.3.16 Authorized Representatives of the City: Those authorized to represent the City shall include Purchasing Agent, Engineers, and Inspectors employed by the City, only.

3.3.17 Stockpiling Materials and Equipment: The Contractor shall stockpile and store materials and equipment within the Permanent and Temporary Easements as shown on the construction plans. The Contractor shall have the boundaries of the easements staked by their surveyor so the construction limits are clearly defined. The Contractor shall keep all construction activities within these easement boundaries at all times.

All materials, stockpiled soils, and construction equipment that is within CDOT right-of-way shall be kept behind protective barriers at all times.

The projects construction footprint on the Colorado Parks and Wildlife property needs to be kept as confined as possible, while still allowing construction activities to be successfully completed.

3.3.18 Traffic Control: The Contractor shall provide and maintain traffic control in accordance with the approved Traffic Control Plan and the Manual on Uniform Traffic Control Devices. A Traffic Control Plan shall be prepared by the Contractor and reviewed and approved by the City and CDOT. The traffic control plan shall be submitted to the City before or at the pre-construction meeting.

The traffic control submittal shall include Methods of Handling Traffic (MHT) for both Interstate 70 westbound and eastbound. The traffic control plan shall also include a detour route around the project area in the worst case scenario that the interstate has to be closed down for roadway repairs due to the boring operation.

3.3.19 Traffic Detector Loops: Not applicable to Project.

3.3.20 Clean-Up: The Contractor shall clear the construction site of all trash and on-site waste daily, including scrap from construction materials. The costs for all clean-up work shall be considered incidental and will not be paid for separately.

3.3.21 Quality Control Testing: Contractor shall refer to Project Specifications in Appendix B for information. The City will hire a 3rd party Quality Assurance testing agency for backfill compaction testing, concrete testing, and any other tests that are deemed necessary.

3.3.22 Uranium Mill Tailings: It is anticipated that radioactive mill tailings will not be encountered on this Project.

3.3.23 Fugitive Petroleum or Other Contamination: It is anticipated that soil contamination from fugitive petroleum or other contaminants will not be encountered with the Project.

3.3.24 Excess Material: All excess materials shall be disposed in accordance with General Contract Condition Section 50.

3.3.25 Construction Equipment Storage: The Contractor shall stockpile and store materials and equipment within the Permanent and Temporary Easements as shown on the construction plans. The Contractor shall have the boundaries of the easements staked by their surveyor so the construction limits are clearly defined. The Contractor shall keep all construction activities within these easement boundaries at all times.

3.3.26 Asphalt Removal and Temporary Asphalt Millings: Not applicable to Project.

3.3.27 Schedule of Submittals: See Appendix A for list of required submittals. The Contractor at a minimum shall deliver these submittals at the pre-construction meeting:

- Construction schedule submitted at or prior to the pre-construction meeting and updated as necessary to reflect actual conditions
- List of contacts for contractor and any subcontractors
- Hourly rate table for labor and equipment to be used on this project
- Method for Handling Traffic (MHT) along Interstate 70, as well as, a proposed detour (closure plan) in the case traffic has to be diverted due to the project.

3.3.28 Existing Utilities and Structures: The location of existing utilities and structures shown on the Plans are approximate. It is the responsibility of the Contractor to locate and protect all structures and utilities in accordance with General Contract Condition Section 37. The Contractor shall coordinate with the utility companies any necessary relocation of utilities and schedule his work accordingly.

3.3.29 Incidental Items: Any item of work not specifically identified or paid for directly, but which is necessary for the satisfactory completion of any paid items of work, will be considered as incidental to those items, and will be included in the cost of those items.

3.3.30 Confined Space Entry: The Contractor is responsible for providing any and all confined space entry safety equipment; including, but not limited to: air testing equipment, fresh air blowers, tripods, harnesses, and SCBA equipment. The Contractor's air monitoring devices shall be calibrated and certified. The cost for all confined space entry equipment shall be incidental to the project cost, and will not be paid for separately.

3.3.31 Domestic (Potable) Water: The Contractor will be responsible for supplying all potable water that will be used on the project for construction purposes. Ute Water fire hydrants are located on Persigo property and may be used as a water source with permission from Ute Water and the installation of backflow safety devices. There is also a water fill station on River Road in front of the Persigo WWTP.

The Contractor will be allowed to use Persigo effluent wastewater (treated wastewater) for moisture-conditioning soil and dust control operations only. Persigo effluent wastewater shall not be used for concrete and/or grouting operations.

3.3.32 Bypass Pumping: Bypass pumping of the treated effluent water during the concrete wall coring, concrete pipe plugging operations, and the diffuser testing phase will be required. The Contractor will be required to provide onsite monitoring of the bypass pumping equipment 24 hours a day while the pumping operation is running. The Contractor will be required to provide backup controls, 48-inch pipe plug, and power equipment for continuous operations of the bypass pumping system.

Monthly average effluent flows, as well as, monthly peaks and minimum effluent flows are provided in Appendix E. These effluent flows are from the past five years for the months of October, November, December and January.

The bypass pumping discharge pipe(s) shall discharge into Persigo Wash next to the existing concrete headwall. Sections of the existing chain-link fence will need to be removed to allow room for the discharge pipe(s).

The Contractor is responsible for all calculations in properly sizing the suction and discharge pipes, and sizing the pump(s) for bypassing the effluent water around the work area. The Contractor shall include in the Bypass Pumping pay item the materials and work necessary for blocking the existing opening into the effluent box immediately downstream of the Plant Water Building.

The Contractor has a maximum of **10-calendar days** for continuous bypass pumping that is paid for Lump Sum. These 10-calendar days do not include the time it takes to setup and teardown the pumping assembly. Additional days of bypass pumping beyond the 10-calendar days shall be paid for by the Contractor at no expense to the City.

The City will be responsible for dismantling the aluminum safety railing at the effluent building so it doesn't interfere with the bypass suction piping.

3.3.33 Existing River Dike: The existing river dike along the south end of the Persigo WWTP property will need to be graded back to existing condition elevations and slopes, and the trench backfill material shall be moisture conditioned and compacted per the project specifications. The existing river dike is located along the new effluent pipeline alignment between SSMH-011 to SSMH-014.

3.3.34 Existing Persigo Effluent Outlet Pipe and Structure: The Contractor needs to be aware that the existing effluent pipe (48" dia.) and headwall structure in Persigo Wash shall remain in service and undisturbed until the State of Colorado gives final acceptance on the new diffuser outfall system.

Once the new diffuser outfall system is complete, the City and the State will perform a color dye test on the diffuser. At this time, the effluent water will need to be diverted into the new diffuser pipeline and the Contractor will need to plug the existing 48" RCP pipeline. Once the wastewater is flowing into the diffuser pipeline, the City will add color dye to the effluent water in order to verify that all seventeen (17) diffuser valves are working properly out in the river. The City anticipates using a boat and a drone with a camera attached to it to try to visually see the dye exiting the diffuser valves. The color dye test will need to be performed when the Colorado River water is clear and at a low flow level.

The diffuser color dye test will need to be performed while the bypass pumping assembly is setup and operational. During diffuser testing, if there are any issues with the diffuser outfall system that require repairs, then the bypass pumps can pump the effluent water back to Persigo Wash while the repairs are being made. The Contractor shall include color dye testing in their construction schedule in order to accommodate the testing while the bypass pumping assembly is setup. The dye testing should take 1-2 days to complete.

Only when the State of Colorado gives the City final approval and acceptance of the diffuser will the Contractor be allowed to start dismantling and abandoning the existing outfall structure and pipeline. At this time, all effluent flow shall be flowing out to the river diffuser.

3.3.35 Steel Casing Pipe Installation: The Contractor shall develop a geotechnical monitoring plan for use during installation of the casing pipe and refer to Section 02445, Instrumentation and Monitoring for monitoring requirements. The geotechnical monitoring plan shall be submitted a minimum of seven (7) days prior to beginning installation of the casing pipe under I-70. At a minimum, the geotechnical monitoring plan shall include:

- Baseline survey of roadway surface before construction begins.
- Survey shall include a minimum of 20 points per direction of I-70 (40 total points)
- 8 points shall be along the proposed casing pipe centerline and 6 points shall be located 10-ft to the east and 10-ft to the west of the boring centerline.

Contractor shall plan for three visual inspections per day (morning, noon, afternoon) of the road surface during boring installation. In addition, the Contractor shall drive I-70 at least once a day in both the westbound and eastbound directions to see if any noticeable change in the roadway surface has occurred.

3.3.36 Plan of Action (POA): The Contractor shall have a Plan of Action developed if settlement is detected. Development and implementation of mitigation measures shall be the responsibility of the Contractor subject to approval of the Engineer, CDOT, and the City of Grand Junction. At a minimum, the POA shall include:

- Project Contacts:
 - CDOT – Joel Berschauer at 970-683-6288
 - Colorado State Patrol
 - City of Grand Junction – Lee Cooper at 970-589-4985
 - Geotech – Mike Berry at 970-255-8005
 - Stantec Engineer – Colin Haggerty at 303-704-8172
- Closure Plan
- Detour Route
- Remediation Subcontractors
- Ground support methods at launch pits
- Mitigation measures if road settles and/or raises

Repair work shall occur 24 hours per day, seven (7) days per week until the road is repaired to CDOT's acceptance.

3.3.37 CDOT Emergency Maintenance Workers: All Bidders shall be aware that if CDOT's emergency maintenance crews are required to close or provide traffic control on I-70 due to a changed roadway surface as a result of the boring operation, that CDOT will bill the Contractor at an hourly rate until the Contractor is able to get control of the situation and take over on traffic control and repair operations. All

repair costs on I-70, if required due to the boring operation, will be the responsibility of the Contractor.

3.3.38 Tideflex Diffuser Manifold: The Contractor shall be aware that there is an 8 – 10 week lead time on the Tideflex diffuser manifold. Once a construction contract is executed and signed, the Contractor shall start the process of ordering the Tideflex diffuser manifold.

3.4. SCOPE OF WORK & SPECIFICATIONS: See Project Manual and Construction Plans.

3.5. Attachments:

- Appendix A: Project Submittal Form
- Appendix B: Project Manual (by Stantec)
- Appendix C: CDPHE's Construction Dewatering Permit APPLICATION ONLY
- Appendix D: USGS Colorado River flows – Daily Average River Flows
- Appendix E: Persigo WWTP Historical Effluent Flows
- Construction Plans

3.6. Contractor Bid Documents: For Contractor's convenience, the following is a list of forms/items to be submitted with the Contractor's bid response. However, should a form/item not be listed in this section, but required in the solicitation documents, it is the Contractor's responsibility to ensure all forms/items are submitted.

- Contractor's Bid Form
- Contractor's Bid Bond
- Price Bid Schedule

3.7. IFB TENTATIVE TIME SCHEDULE:

Invitation for Bids available:	May 11, 2018
Mandatory Pre-Bid Meeting:	May 23, 2018
Inquiry deadline, no questions after this date:	May 25, 2018
Addendum Posted:	May 30, 2018
Submittal deadline for proposals (Bid Opening):	June 5, 2018
City Council or Board of Commissioners Approval:	June 18, 2018
Notice of Award & Contract execution:	June 19, 2018
Bonding & Insurance Cert. due:	July 3, 2018
Preconstruction meeting:	August 14, 2018
Work begins:	August 27, 2018
Final Completion:	173 Calendar Days from Notice to Proceed

4. Contractor's Bid Form

Bid Date: _____

Project: IFB-4534-18-DH "Persigo WWTP – Diffuser Outfall Improvements Project
(RE-BID"

Bidding Company: _____

Name of Authorized Agent: _____

Email _____

Telephone _____ **Address** _____

City _____ **State** _____ **Zip** _____

The undersigned Bidder, in compliance with the Invitation for Bids, having examined the Instruction to Bidders, General Contract Conditions, Statement of Work, Specifications, and any and all Addenda thereto, having investigated the location of, and conditions affecting the proposed work, hereby proposes to furnish all labor, materials and supplies, and to perform all work for the Project in accordance with Contract Documents, within the time set forth and at the prices stated below. These prices are to cover all expenses incurred in performing the work required under the Contract Documents, of which this Contractor's Bid Form is a part.

The undersigned Contractor does hereby declare and stipulate that this offer is made in good faith without collusion or connection to any person(s) providing an offer for the same work, and that it is made in pursuance of, and subject to, all terms and conditions of the Instructions to Bidders, the Specifications, and all other Solicitation Documents, all of which have been examined by the undersigned.

The Contractor also agrees that if awarded the Contract, to provide insurance certificates within ten (10) working days of the date of Notification of Award. Submittal of this offer will be taken by the Owner as a binding covenant that the Contractor will be prepared to complete the project in its entirety.

The Owner reserves the right to make the award on the basis of the offer deemed most favorable, to waive any formalities or technicalities and to reject any or all offers. It is further agreed that this offer may not be withdrawn for a period of sixty (60) calendar days after closing time. Submission of clarifications and revised offers automatically establish a new thirty day (30) period.

RECEIPT OF ADDENDA: the undersigned Contractor acknowledges receipt of Addenda to the Solicitation, Specifications, and other Contract Documents.

State number of Addenda received: _____.

It is the responsibility of the Bidder to ensure all Addenda have been received and acknowledged.

Authorized Signature: _____

Title: _____

Bid Schedule: Persigo WWTP - Diffuser Outfall Improvements Project

Item No.	CDOT, City Ref.	Description	Quantity	Units	Unit Price	Total Price
1	201, 01025	Clearing and Grubbing	1.	Lump Sum	---	\$ _____
2	202, 01025	Remove and Replace Fence (Match in Kind)	150.	Lin. Ft.	\$ _____	\$ _____
3	207, 01025	Topsoil	2,500.	Cu. Yd.	\$ _____	\$ _____
4	207, 01025	Stockpile Topsoil	2,500.	Cu. Yd.	\$ _____	\$ _____
5	208, 01025	Silt Fence	800.	Lin. Ft.	\$ _____	\$ _____
6	208, 01025	Erosion Log Type 1 (20 Inch)	250.	Lin. Ft.	\$ _____	\$ _____
7	208, 01025	Temporary Berms	4,000.	Lin. Ft.	\$ _____	\$ _____
8	208, 01025	Soil Lifts (3' High) (Includes Soil Retention Blanket, Topsoil, Fill, Stakes/Staples)	100.	Lin. Ft.	\$ _____	\$ _____
9	208, 01025	Storm Drain Inlet Protection (Type 1)	20.	Lin. Ft.	\$ _____	\$ _____
10	208, 01025	Sediment Trap	3.	Each	\$ _____	\$ _____
11	208, 01025	Pre-fabricated Concrete Washout Structure	2.	Each	\$ _____	\$ _____
12	208, 01025	Vehicle Tracking Pad	2.	Each	\$ _____	\$ _____
13	208, 01025	Erosion Control Management (ECM)	1.	Lump Sum	---	\$ _____
14	208, 01025	Temporary Diversion (Coffer Dam) (Colorado River)	1.	Lump Sum	---	\$ _____
15	208, 01025	Temporary Stream Crossing (Persigo Wash)	1.	Lump Sum	---	\$ _____
16	212, 02935	Seeding (Native)	4.1	Acre	\$ _____	\$ _____
17	212, 02935	Soil Conditioning	4.1	Acre	\$ _____	\$ _____
18	213	Mulching (Hydraulic)	4.1	Acre	\$ _____	\$ _____

Bid Schedule: Persigo WWTP - Diffuser Outfall Improvements Project

Item No.	CDOT, City Ref.	Description	Quantity	Units	Unit Price	Total Price
19	214, 01025	Landscape Maintenance (One-Year from Landscape Completion)	1.	Lump Sum	---	\$ _____
20	506, 01025	Riprap (D ₅₀ = 9 Inch)	120.	Cu. Yd.	\$ _____	\$ _____
21	607, 01025	Fence Double Gate (6' High) (Chain-Link, Barbed Wire Top, Top Rail) (Southwest Corner of the Persigo Property near SSMH-0014)	24.	Lin. Ft.	\$ _____	\$ _____
22	607	Fence (Plastic) (Temporary fencing to be used around bore pits)	650.	Lin. Ft.	\$ _____	\$ _____
23	01025, 02612	Furnish and Install 60" I.D. Steel Pipe Casing (Trenchless)	420.	Lin. Ft.	\$ _____	\$ _____
24	01025, 15064	Furnish and Install 54" O.D. HDPE Pipe	720.	Lin. Ft.	\$ _____	\$ _____
25	01025, 15074	Furnish and Install 48" I.D. RCP Pipe or Equivalent	1,250.	Lin. Ft.	\$ _____	\$ _____
26	604, 01025	Manhole Slab Base (10 Foot)	4.	Each	\$ _____	\$ _____
27	604, 01025	Manhole Slab Base (15 Foot)	2.	Each	\$ _____	\$ _____
28	604, 01025	Manhole Slab Base (20 Foot)	1.	Each	\$ _____	\$ _____
29	01025, 03300	Effluent Box	1.	Lump Sum	---	\$ _____
30	01025, 11001	Diffuser Structure	1.	Lump Sum	---	\$ _____
31	202, 01025	Remove 24 LF Existing Effluent Pipe and Headwall	1.	Lump Sum	---	\$ _____
32	01025, 02300	Abandon Effluent Pipe in Place (Includes Flow-fill)	1.	Lump Sum	---	\$ _____
33	01025	Cleanup and Restoration	1.	Lump Sum	---	\$ _____
34	01025	Rock Excavation (Bedrock)	200.	Cu. Yd.	\$ _____	\$ _____
35	01025	Bypass Pumping (Effluent Flows) (10-Calendar Days) (Includes 48" Pipe Plug and Stop Plate Installation and Removal)	1.	Lump Sum	---	\$ _____

Bid Schedule: Persigo WWTP - Diffuser Outfall Improvements Project

Item No.	CDOT, City Ref.	Description	Quantity	Units	Unit Price	Total Price
36	614	Traffic Control (Complete in Place) (All Traffic Control shall meet CDOT Standard Requirements and Details for Highway Construction)	1.	Lump Sum	---	\$ _____
37	614	Traffic Control Plan(s)	1.	Lump Sum	---	\$ _____
38	620	Sanitary Facility	2.	Each	\$ _____	\$ _____
39	625	Construction Surveying	1.	Lump Sum	---	\$ _____
40	629	Survey Monumentation (Complete in Place)	1.	Each	\$ _____	\$ _____
41	630	Concrete Barrier (Temporary) (To be used within CDOT right-of-way for protection along bore pit excavations)	450.	Lin. Ft.	\$ _____	\$ _____
42	630	Impact Attenuator (Temporary)	2.	Each	\$ _____	\$ _____
43	01025	Mobilization and Demobilization	1.	Lump Sum	---	\$ _____
MCR		Minor Contract Revisions	---	---	---	\$ <u>175,000.00</u>
Bid Amount:						\$ _____

Bid Amount:

dollars

Contractor Name:
Contractor Address:
Contractor Phone #:
Contractor's Proposed Boring Method:

The undersigned Bidder proposes to subcontract the following portion of Work:

<u>Name & address of Sub-Contractor</u>	<u>Description of work to be performed</u>	<u>% of Contract</u>
_____	_____	_____
_____	_____	_____
_____	_____	_____
_____	_____	_____

The undersigned Bidder acknowledges the right of the City to reject any and all Bids submitted and to waive informalities and irregularities therein in the City's sole discretion.

By submission of the Bid, each Bidder certifies, and in the case of a joint Bid each party thereto certifies as to his own organization, that this Bid has been arrived at independently, without collusion, consultation, communication, or agreement as to any matter relating to this Bid with any other Bidder or with any competitor.

Appendix A

Project Submittal Form

PROJECT SUBMITTAL FORM

PROJECT: **Persigo WWTP – Diffuser Outfall Improvements Project**

CONTRACTOR:

PROJECT ENGINEER: Lee Cooper

Description	Date Received	Resubmittal Requested	Resubmittal Received	Date Accepted
-------------	---------------	-----------------------	----------------------	---------------

DIFFUSER OUTFALL CONSTRUCTION

48 Inch RCP Pipe or Equivalent				
54 Inch HDPE Pipe				
60 Inch Steel Casing Pipe				
Manhole Structures				
Pipe Bedding Material				
Wide-bill Duckbill Diffuser Assembly by TideFlex				
Casing Spacers				
Casing Pipe End Caps				
Concrete Mix Design				
Steel Reinforcement				
Non-Shrink Grout				
Interstate 70 – Plan of Action (POA)				
Temporary Diversion (Coffer Dam)				
Bypass Pumping Plan (Effluent Flows)				
Riprap (D ₅₀ = 9")				
Soil Conditioning				
Mulching				
Seeding (Native)				
Soil Lift Fabric				
Labor and Equipment hourly rate table				
Construction Schedule				

APPENDIX B

Project Manual

CONSTRUCTION SPECIFICATIONS

PERSIGO WASH WASTEWATER TREATMENT PLANT DIFFUSER OUTFALL

GRAND JUNCTION, COLORADO

January, 2018



2000 S. Colorado Boulevard, Suite 2-300
Denver, CO 80222

(SEAL)

CONTRACT DOCUMENTS

**CONDITIONS OF THE
CONTRACT**

SOILS REPORT



Huddleston-Berry
Engineering & Testing, LLC

**GEOLOGIC HAZARDS AND GEOTECHNICAL
INVESTIGATION
PERSIGO WASTEWATER TREATMENT PLANT
OUTFALL
GRAND JUNCTION, COLORADO
PROJECT#01543-0001**

**STANTEC CONSULTING, LTD
2000 S. COLORADO BOULEVARD, SUITE 2-300
DENVER, COLORADO 80222**

OCTOBER 10, 2017

**Huddleston-Berry Engineering and Testing, LLC
640 White Avenue, Unit B
Grand Junction, Colorado 81501**

TABLE OF CONTENTS

1.0	INTRODUCTION	1
1.1	Scope.....	1
1.2	Site Location and Description.....	1
1.3	Proposed Construction	1
2.0	GEOLOGIC SETTING	2
2.1	Soils.....	2
2.2	Geology.....	2
2.3	Groundwater	2
3.0	FIELD INVESTIGATION	2
3.1	Subsurface Investigation.....	2
4.0	LABORATORY TESTING.....	3
5.0	GEOLOGIC INTERPRETATION	4
5.1	Geologic Hazards.....	4
5.2	Geologic Constraints.....	4
5.3	Water Resources	4
5.4	Mineral Resources	4
6.0	CONCLUSIONS.....	4
7.0	RECOMMENDATIONS	4
7.1	Trenchless Construction Feasibility.....	4
7.2	Corrosion of Concrete.....	5
7.3	Corrosion of Steel	5
7.4	Lateral Earth Pressures	5
7.5	Excavations	5
8.0	GENERAL	5

FIGURES

- Figure 1 – Site Location Map
- Figure 2 – Site Plan
- Figure 3 – Fence Diagram

APPENDICES

- Appendix A – UDSA NRCS Soil Survey Data
- Appendix B – Typed Boring and Test Pit Logs
- Appendix C – Laboratory Testing Results

1.0 INTRODUCTION

As part of continued infrastructure improvements, the City of Grand Junction intends to construct a new outfall for the Persigo Wastewater Treatment Plant (WWTP). As part of the design development process, Huddlestone-Berry Engineering and Testing, LLC (HBET) was retained by Stantec to conduct a geologic hazards and geotechnical investigation at the site.

1.1 Scope

As discussed above, a geologic hazards and geotechnical investigation was conducted for the Persigo WWTP Outfall project in Grand Junction, Colorado. The scope of the investigation included the following components:

- Conducting a subsurface investigation to evaluate the subsurface conditions at the site.
- Providing recommendations for trenchless excavation, trench excavation, and general earthwork procedures.
- Evaluating potential geologic hazards at the site.

The investigation and report were completed by a Colorado registered professional engineer in accordance with generally accepted geotechnical and geological engineering practices. This report has been prepared for the exclusive use of Stantec and the City of Grand Junction.

1.2 Site Location and Description

The site is located south of the Persigo WWTP in Grand Junction, Colorado. The project location is shown on Figure 1 – Site Location Map.

The project area had a general slight downward slope to the south. However, Interstate 70 ran through the project area and the highway lanes sat on large earthen embankments. The Mesa County Riverfront Trail ran through the southern portion of the site.

1.3 Proposed Construction

The proposed construction is anticipated to include a new outfall from the Persigo WWTP to the Colorado River. As part of the construction, the new outfall pipe will be bored beneath I-70.

2.0 GEOLOGIC SETTING

2.1 Soils

Soils data was obtained from the USDA Natural Resource Conservation Service Web Soil Survey. The data indicates that the site is underlain by Sagers silty clay loam saline, 0 to 2 percent slopes, and Bebeever and Green River soils, and Riverwash, 0 to 2 percent slopes. Soil survey data is included in Appendix A.

Excavation in the site soils is described as being somewhat limited to very limited due to dust, unstable excavation walls, and/or depth to saturated zone. The site soils are indicated to have a low to moderate potential for frost action, moderate to high risk of corrosion of uncoated steel, and low to high risk of corrosion of concrete.

2.2 Geology

According to the *Geologic Map of Colorado* by Ogden Tweto (1979), the site is underlain by Quaternary alluvium. The alluvium is underlain by Mancos shale bedrock. The Mancos shale unit is thick in the Grand Valley and has a low to moderate potential for expansion.

2.3 Groundwater

Groundwater was encountered in the subsurface at depths of between 5.0 and 14.5 feet below the ground surface at the time of the investigation.

3.0 FIELD INVESTIGATION

3.1 Subsurface Investigation

The subsurface investigation was conducted on April 14th, 2016 and consisted of five geotechnical borings. The borings were drilled to depths of between 16.0 and 23.0 feet below the existing ground surface. Supplemental subsurface investigation was conducted on September 9th, 2017 and consisted of two test pits. The test pits were excavated to depths of between 10.0 and 13.0 feet below the existing ground surface. Boring and test pit locations are shown on Figure 2 – Site Plan. Typed boring and test pit logs are included in Appendix B. Samples of the native soils were collected during Standard Penetration Testing (SPT) and using bulk sampling methods at the locations shown on the logs.

As shown on the logs, the subsurface conditions were variable. Boring B-1, conducted in the north shoulder of the westbound lanes of I-70, encountered asphalt pavement above sandy gravel fill to a depth of 10.0 feet. Below the fill, brown, moist to wet, medium dense silty sand with gravel extended to a depth of 15.0 feet. The sand was underlain by brown, wet, dense sandy gravel and cobbles to the bottom of the boring. Groundwater was encountered in B-1 at a depth of 10.5 feet at the time of the investigation.

Boring B-2, conducted in the I-70 median, encountered 5.0 feet of brown, moist, medium dense clayey sand with gravel above brown, moist to wet, dense sandy gravel and cobbles to a depth of 17.0 feet. The gravel and cobble soils were underlain by black, hard, highly weathered shale bedrock to the bottom of the boring. Groundwater was encountered in B-2 at a depth of 6.0 feet at the time of the investigation.

Boring B-3, conducted in the south shoulder of the eastbound lanes of I-70, encountered asphalt pavement above sandy gravel fill to a depth of 9.5 feet. Below the fill, brown, moist to wet, dense sandy gravel and cobbles extended to the bottom of the boring. Groundwater was encountered in B-3 at a depth of 14.5 feet at the time of the investigation.

Boring B-4, conducted south of the Mesa County Riverfront Trail, encountered brown, moist to wet, very loose silty sand from the ground surface to a depth of 12.0 feet. The sand was underlain by brown, wet, dense sandy gravel and cobbles to a depth of 17.0 feet. Below the gravel and cobble soils, black, hard, highly weathered shale bedrock extended to the bottom of the boring. Groundwater was encountered in B-4 at a depth of 5.0 feet at the time of the investigation.

Boring B-5, conducted near the southwest corner of the Persigo WWTP property, encountered brown, moist to wet, medium dense to dense sandy gravel and cobbles from the ground surface to the bottom of the boring. Groundwater was encountered in B-5 at a depth of 8.0 feet at the time of the investigation.

Test Pit TP-1, conducted in the I-70 median encountered 2.0 feet of gravelly clay fill materials above brown, moist, medium dense clayey sand with gravel to a depth of 5.0 feet. The sand was underlain by brown, moist to wet, dense sandy gravel and cobbles to the bottom of the excavation. Groundwater was encountered in TP-1 at a depth of 9.0 feet at the time of the investigation.

Test Pit TP-2, conducted on the north side of I-70, encountered 2.0 feet of topsoil above brown, moist, medium dense clayey sand with gravel to a depth of 7.0 feet. The sand was underlain by brown, moist to wet, dense sandy gravel and cobbles to the bottom of the excavation. Groundwater was encountered in TP-2 at a depth of 8.0 feet at the time of the investigation.

4.0 LABORATORY TESTING

Selected representative samples of the sandy gravel and cobble soils collected from the test pits were tested in the Huddlestone-Berry Engineering and Testing LLC geotechnical laboratory for natural moisture content, gradation, and Atterberg limits. In addition, unconfined compression testing was conducted on cores drilled from the native cobbles and boulders. The laboratory testing results are included in Appendix C.

5.0 GEOLOGIC INTERPRETATION

5.1 Geologic Hazards

The only geologic hazard identified on the site is the presence of shallow groundwater.

5.2 Geologic Constraints

In general, the primary geologic constraint to construction at the site is the presence of shallow groundwater. However, the granular nature of the soils may also impact the trenchless construction below I-70.

5.3 Water Resources

No water supply wells were observed in the project area. As discussed previously, shallow groundwater was encountered in the subsurface. In general, with proper design and construction, the proposed construction is not anticipated to adversely impact surface water or groundwater.

5.4 Mineral Resources

Potential mineral resources in western Colorado generally include gravel, uranium ore, and commercial rock products such as flagstone. As discussed previously, gravels were encountered in the subsurface at the site. However, HBET does not believe that the gravels at the site represent an economically recoverable resource.

6.0 CONCLUSIONS

Based upon the available data sources, field investigation, and nature of the proposed construction, HBET does not believe that there are any geologic conditions which should preclude construction at this site. However, shallow groundwater will likely impact the construction.

7.0 RECOMMENDATIONS

7.1 Trenchless Construction Feasibility

Figure 3 is a fence diagram generated from the geotechnical data based upon profiles provided by Stantec. Although the ground surface elevations of the borings are estimates from the Mesa County GIS database, the diagram suggests that the entire bore under I-70 will be conducted in granular materials below the water table. As a result, the suitable methods for trenchless construction are limited.

In general, based upon the soil conditions at the site, microtunneling is the preferred method of installing the outfall line. However, it is recommended that the actual method used be selected by a contractor with extensive experience with granular soils and shallow groundwater conditions.

7.2 Corrosion of Concrete

The USDA soil survey data indicates that the native soils have a low to high risk of corrosion of concrete. As a result, at a minimum, Type I-II sulfate resistant cement is recommended for this site.

7.3 Corrosion of Steel

As discussed previously, the USDA Soil Survey data indicate that the native soils are moderately to highly corrosive to uncoated steel. As a result, corrosion should be considered in design of any steel elements proposed to be used as part of the construction.

7.4 Lateral Earth Pressures

Any shoring or retaining walls should be designed to resist lateral earth pressures. For backfill consisting of the native soils or imported granular, non-free draining, non-expansive material, we recommend that the walls be designed for an equivalent fluid unit weight of 55 pcf in areas where no surcharge loads are present. Lateral earth pressures should be increased as necessary to reflect any surcharge loading behind the walls. Native shale materials should not be used as backfill.

7.5 Excavations

Excavations in the soils at the site may stand for short periods of time but should not be considered to be stable. In general, the site soils classify as Type C soil with regard to OSHA's Construction Standards for Excavations. For Type C soils, the maximum allowable slope in temporary cuts is 1.5H:1V. However, based upon the granular nature of the soils and shallow groundwater conditions, shoring may be required. In addition, dewatering may be required.

8.0 GENERAL

The recommendations included above are based upon the results of the subsurface investigation and on our local experience. These conclusions and recommendations are valid only for the proposed construction.

As discussed previously, the subsurface conditions at the site were variable. However, the precise nature and extent of any subsurface variability may not become evident until construction. Therefore, it is recommended that a representative of HBET observe excavations to verify that the subsurface conditions are consistent with those described herein.

Huddlestone-Berry Engineering and Testing, LLC is pleased to be of service to your project. Please contact us if you have any questions or comments regarding the contents of this report.

Respectfully Submitted:
Huddlestone-Berry Engineering and Testing, LLC



Michael A. Berry, P.E.
Vice President of Engineering

FIGURES

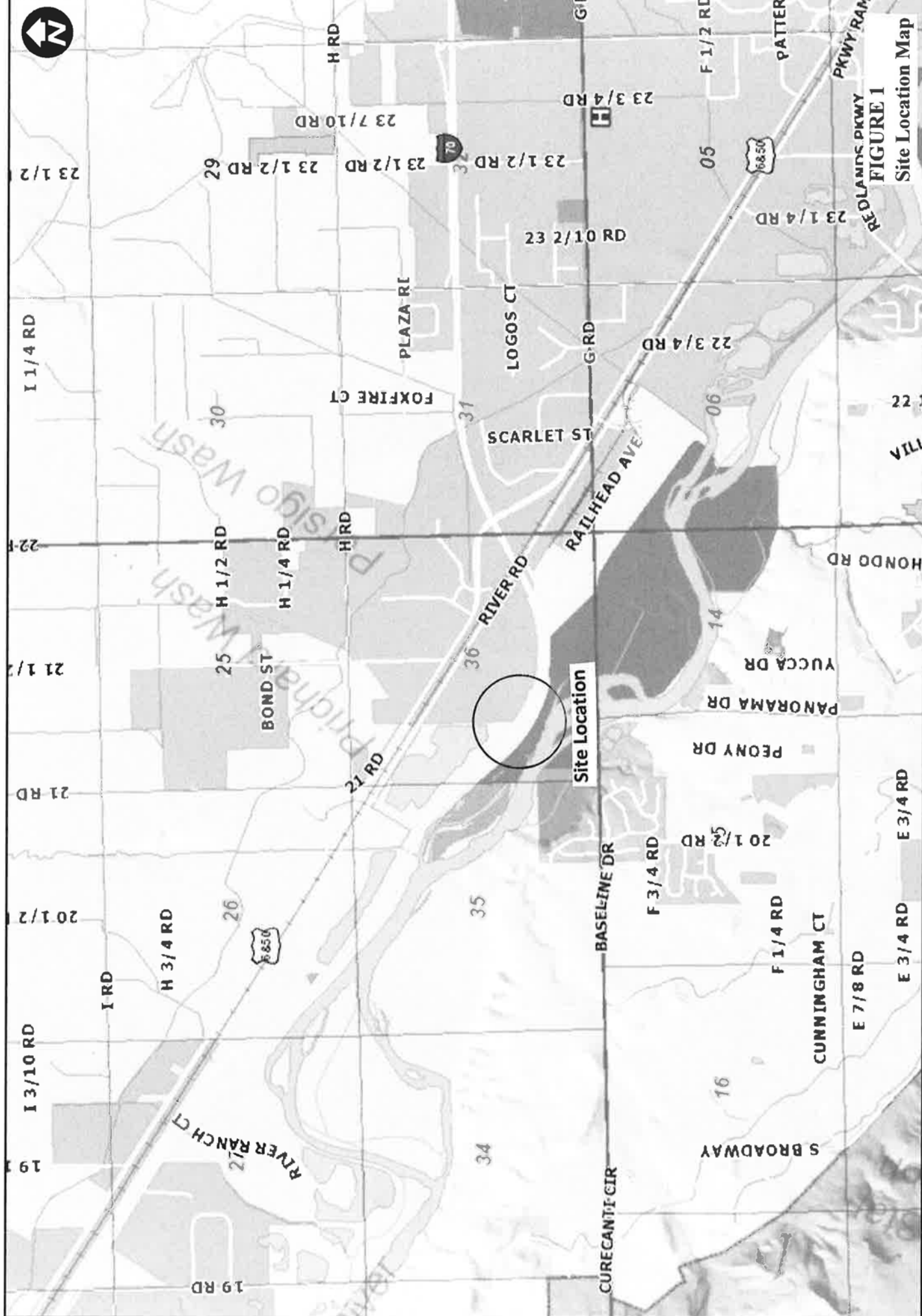

Mesa County Map

The Geographic Information System (GIS) and its components are designed as a source of reference for answering inquiries. Planning and for modeling. GIS is not intended or does not replace legal description information in the chain of title and other information contained in official government records such as the County Clerk and Records office or the courts. In addition, the representations of location in the GIS cannot be substituted for actual legal surveys. The information is believed accurate and suitable for the intended uses and subject to the limitations set forth above. Mesa County makes no warranty as to the accuracy or suitability of any information contained herein. User's assume.

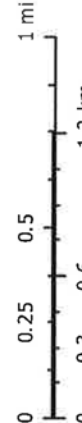

Print Date: May 6, 2016

FIGURE 1
Site Location Map

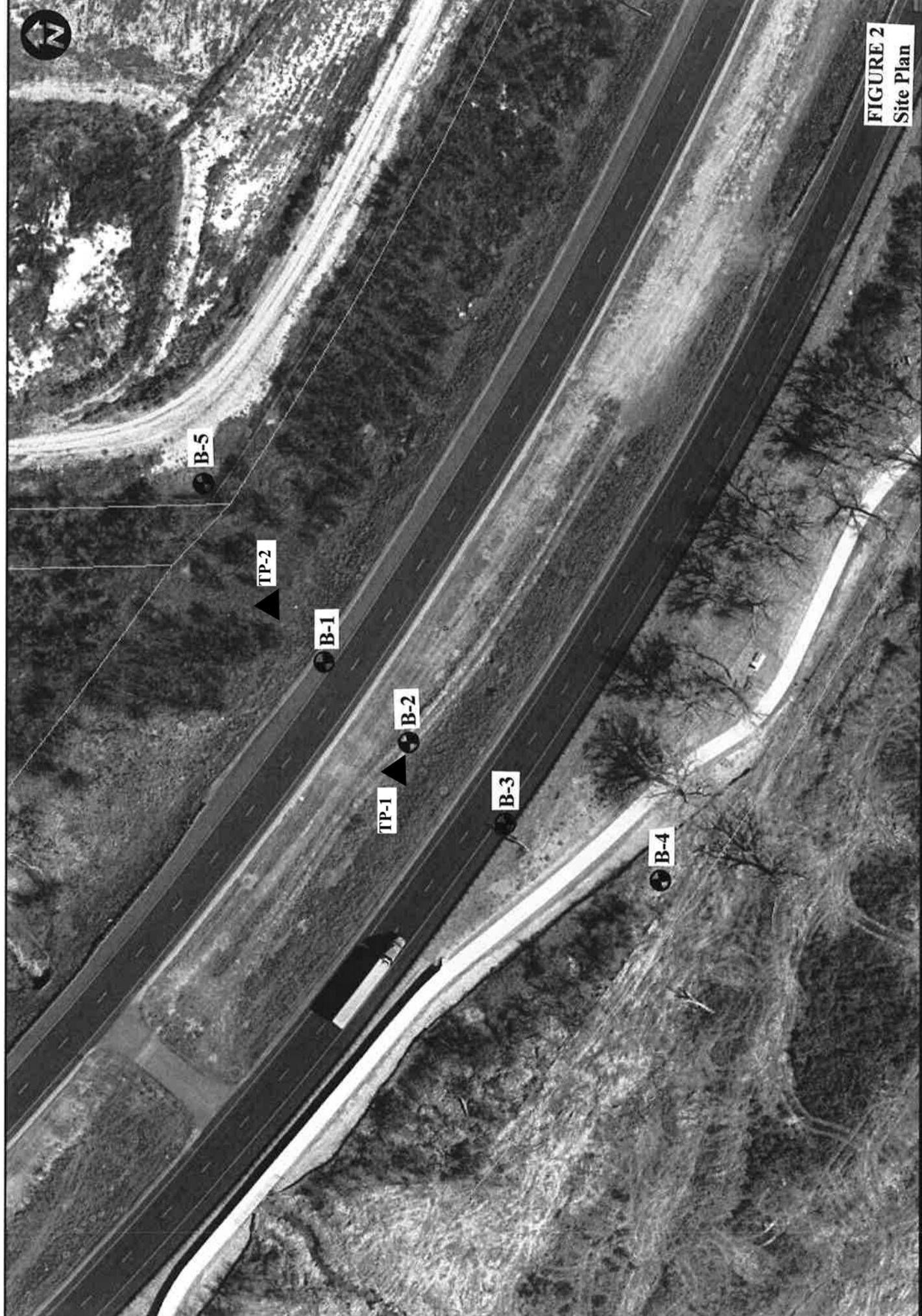

FIGURE 2
Site Plan

Mesa County Map

The Geographic Information System (GIS) and its components are designed as a source of reference for answering inquiries or planning and for modeling. GIS is not intended or does not replace legal description information in the chain of title and other information contained in official government records such as the County Clerk and Records Office or the courts. In addition, the location of the GIS data is not intended to be used for legal purposes. The information is provided as a reference only and is not intended to be used for legal purposes. The information is provided as a reference only and is not intended to be used for legal purposes. The information is provided as a reference only and is not intended to be used for legal purposes. Users assume the responsibility for the accuracy or suitability of any information connected herein. Users assume the responsibility for the accuracy or suitability of any information connected herein. Users assume the responsibility for the accuracy or suitability of any information connected herein.

Print Date: May 9, 2016



Mesa County, Colorado
GIS/IT Department

SUBSURFACE DIAGRAM

CLIENT Stantec

PROJECT NAME Persigo Outfall

PROJECT NUMBER 01543-0001

PROJECT LOCATION Grand Junction, CO

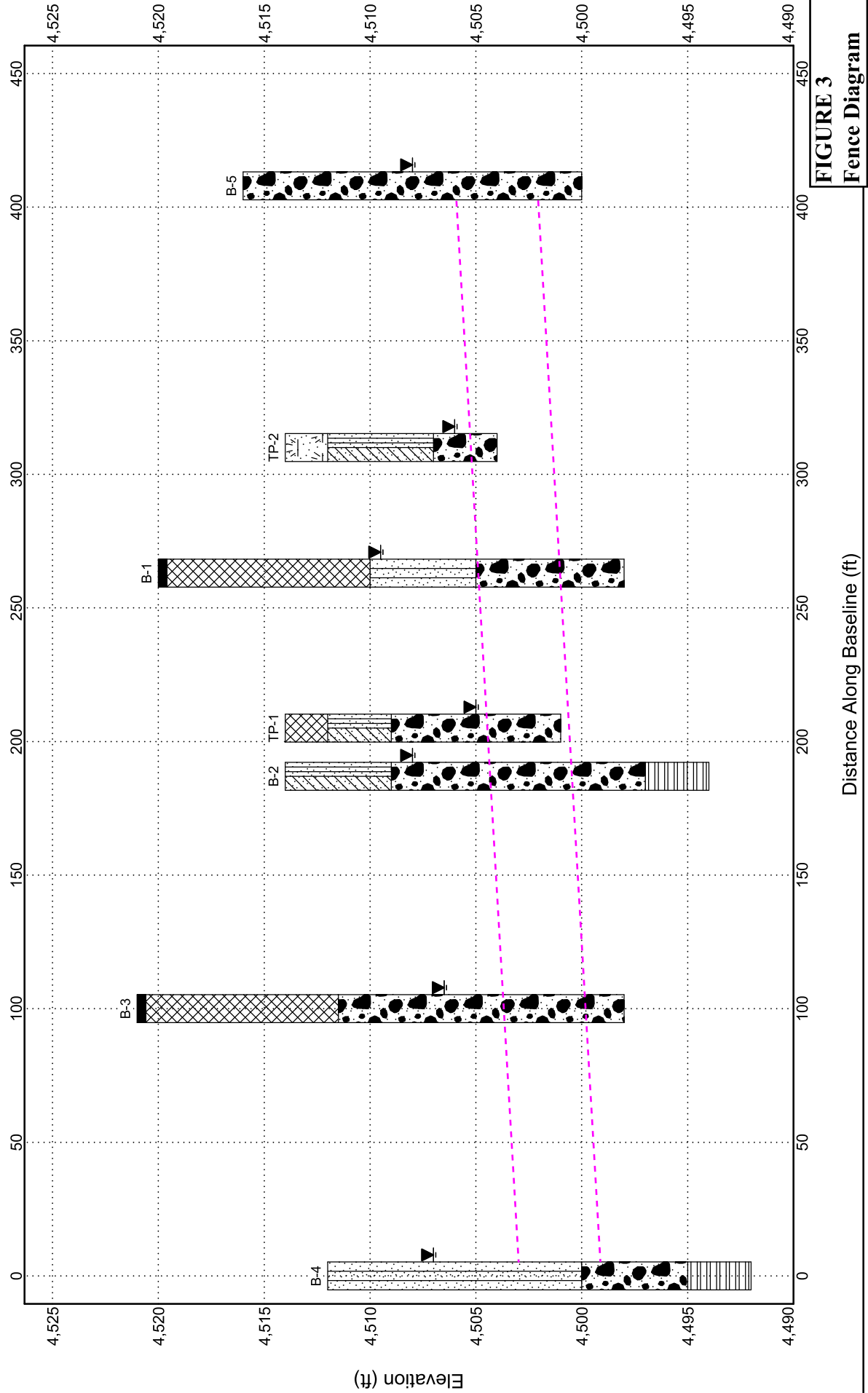

FIGURE 3
Fence Diagram

Distance Along Baseline (ft)

Elevation (ft)

APPENDIX A
Soil Survey Data

Soil Map—Mesa County Area, Colorado





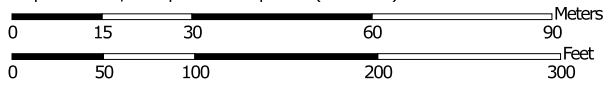

































Map Scale: 1:1,260 if printed on A portrait (8.5" x 11") sheet.



Map projection: Web Mercator Corner coordinates: WGS84 Edge tics: UTM Zone 12N WGS84



MAP LEGEND

-  Area of Interest (AOI)
-  Soil Map Unit Polygons
-  Soil Map Unit Lines
-  Soil Map Unit Points
- Special Point Features**
-  Blowout
-  Borrow Pit
-  Clay Spot
-  Closed Depression
-  Gravel Pit
-  Gravelly Spot
-  Landfill
-  Lava Flow
-  Marsh or swamp
-  Mine or Quarry
-  Miscellaneous Water
-  Perennial Water
-  Rock Outcrop
-  Saline Spot
-  Sandy Spot
-  Severely Eroded Spot
-  Sinkhole
-  Slide or Slip
-  Sodic Spot
-  Spoil Area
-  Stony Spot
-  Very Stony Spot
-  Wet Spot
-  Other
-  Special Line Features
- Water Features**
-  Streams and Canals
- Transportation**
-  Rails
-  Interstate Highways
-  US Routes
-  Major Roads
-  Local Roads
- Background**
-  Aerial Photography

MAP INFORMATION

The soil surveys that comprise your AOI were mapped at 1:24,000.

Warning: Soil Map may not be valid at this scale.

Enlargement of maps beyond the scale of mapping can cause misunderstanding of the detail of mapping and accuracy of soil line placement. The maps do not show the small areas of contrasting soils that could have been shown at a more detailed scale.

Please rely on the bar scale on each map sheet for map measurements.

Source of Map: Natural Resources Conservation Service
 Web Soil Survey URL: <http://websoilsurvey.nrcs.usda.gov>
 Coordinate System: Web Mercator (EPSG:3857)

Maps from the Web Soil Survey are based on the Web Mercator projection, which preserves direction and shape but distorts distance and area. A projection that preserves area, such as the Albers equal-area conic projection, should be used if more accurate calculations of distance or area are required.

This product is generated from the USDA-NRCS certified data as of the version date(s) listed below.

Soil Survey Area: Mesa County Area, Colorado
 Survey Area Data: Version 6, Sep 23, 2015

Soil map units are labeled (as space allows) for map scales 1:50,000 or larger.

Date(s) aerial images were photographed: Jun 22, 2010—Sep 2, 2010

The orthophoto or other base map on which the soil lines were compiled and digitized probably differs from the background imagery displayed on these maps. As a result, some minor shifting of map unit boundaries may be evident.

Map Unit Legend

Mesa County Area, Colorado (CO680)			
Map Unit Symbol	Map Unit Name	Acres in AOI	Percent of AOI
BcS	Sagers silty clay loam, saline, 0 to 2 percent slopes	2.3	83.0%
Ro	Bebeevar and Green River soils, and Riverwash, 0 to 2 percent slopes	0.5	17.0%
Totals for Area of Interest		2.8	100.0%

Map Unit Description

The map units delineated on the detailed soil maps in a soil survey represent the soils or miscellaneous areas in the survey area. The map unit descriptions in this report, along with the maps, can be used to determine the composition and properties of a unit.

A map unit delineation on a soil map represents an area dominated by one or more major kinds of soil or miscellaneous areas. A map unit is identified and named according to the taxonomic classification of the dominant soils. Within a taxonomic class there are precisely defined limits for the properties of the soils. On the landscape, however, the soils are natural phenomena, and they have the characteristic variability of all natural phenomena. Thus, the range of some observed properties may extend beyond the limits defined for a taxonomic class. Areas of soils of a single taxonomic class rarely, if ever, can be mapped without including areas of other taxonomic classes. Consequently, every map unit is made up of the soils or miscellaneous areas for which it is named and some minor components that belong to taxonomic classes other than those of the major soils.

Most minor soils have properties similar to those of the dominant soil or soils in the map unit, and thus they do not affect use and management. These are called noncontrasting, or similar, components. They may or may not be mentioned in a particular map unit description. Other minor components, however, have properties and behavioral characteristics divergent enough to affect use or to require different management. These are called contrasting, or dissimilar, components. They generally are in small areas and could not be mapped separately because of the scale used. Some small areas of strongly contrasting soils or miscellaneous areas are identified by a special symbol on the maps. If included in the database for a given area, the contrasting minor components are identified in the map unit descriptions along with some characteristics of each. A few areas of minor components may not have been observed, and consequently they are not mentioned in the descriptions, especially where the pattern was so complex that it was impractical to make enough observations to identify all the soils and miscellaneous areas on the landscape.

The presence of minor components in a map unit in no way diminishes the usefulness or accuracy of the data. The objective of mapping is not to delineate pure taxonomic classes but rather to separate the landscape into landforms or landform segments that have similar use and management requirements. The delineation of such segments on the map provides sufficient information for the development of resource plans. If intensive use of small areas is planned, however, onsite investigation is needed to define and locate the soils and miscellaneous areas.

An identifying symbol precedes the map unit name in the map unit descriptions. Each description includes general facts about the unit and gives important soil properties and qualities.

Soils that have profiles that are almost alike make up a *soil series*. All the soils of a series have major horizons that are similar in composition, thickness, and arrangement. Soils of a given series can differ in texture of the surface layer, slope, stoniness, salinity, degree of erosion, and other characteristics that affect their use. On the basis of such differences, a soil series is divided into *soil phases*. Most of the areas shown on the detailed soil maps are phases of soil series. The name of a soil phase commonly indicates a feature that affects use or management. For example, Alpha silt loam, 0 to 2 percent slopes, is a phase of the Alpha series.

Some map units are made up of two or more major soils or miscellaneous areas. These map units are complexes, associations, or undifferentiated groups.

A *complex* consists of two or more soils or miscellaneous areas in such an intricate pattern or in such small areas that they cannot be shown separately on the maps. The pattern and proportion of the soils or miscellaneous areas are somewhat similar in all areas. Alpha-Beta complex, 0 to 6 percent slopes, is an example.

An *association* is made up of two or more geographically associated soils or miscellaneous areas that are shown as one unit on the maps. Because of present or anticipated uses of the map units in the survey area, it was not considered practical or necessary to map the soils or miscellaneous areas separately. The pattern and relative proportion of the soils or miscellaneous areas are somewhat similar. Alpha-Beta association, 0 to 2 percent slopes, is an example.

An *undifferentiated group* is made up of two or more soils or miscellaneous areas that could be mapped individually but are mapped as one unit because similar interpretations can be made for use and management. The pattern and proportion of the soils or miscellaneous areas in a mapped area are not uniform. An area can be made up of only one of the major soils or miscellaneous areas, or it can be made up of all of them. Alpha and Beta soils, 0 to 2 percent slopes, is an example.

Some surveys include *miscellaneous areas*. Such areas have little or no soil material and support little or no vegetation. Rock outcrop is an example.

Additional information about the map units described in this report is available in other soil reports, which give properties of the soils and the limitations, capabilities, and potentials for many uses. Also, the narratives that accompany the soil reports define some of the properties included in the map unit descriptions.

Report—Map Unit Description

Mesa County Area, Colorado

BcS—Sagers silty clay loam, saline, 0 to 2 percent slopes

Map Unit Setting

National map unit symbol: k0bs

Elevation: 4,500 to 4,900 feet

Mean annual precipitation: 5 to 8 inches

Mean annual air temperature: 50 to 54 degrees F

Frost-free period: 150 to 190 days

Farmland classification: Not prime farmland

Map Unit Composition

Sagers, saline, and similar soils: 90 percent

Minor components: 10 percent

Estimates are based on observations, descriptions, and transects of the mapunit.

Description of Sagers, Saline

Setting

Landform: Alluvial fans, terraces

Landform position (three-dimensional): Tread

Down-slope shape: Concave

Across-slope shape: Linear

Parent material: Alluvium derived from calcareous shale and sandstone

Typical profile

Ap - 0 to 12 inches: silty clay loam

C - 12 to 25 inches: silty clay loam

Cy - 25 to 60 inches: silty clay loam

Properties and qualities

Slope: 0 to 2 percent

Depth to restrictive feature: More than 80 inches

Natural drainage class: Well drained

Runoff class: Low

Capacity of the most limiting layer to transmit water (Ksat):

Moderately high (0.20 to 0.60 in/hr)

Depth to water table: More than 80 inches

Frequency of flooding: None

Frequency of ponding: None

Calcium carbonate, maximum in profile: 15 percent

Gypsum, maximum in profile: 5 percent

Salinity, maximum in profile: Strongly saline (16.0 to 32.0 mmhos/cm)

Available water storage in profile: Very low (about 3.0 inches)

Interpretive groups

Land capability classification (irrigated): None specified

Land capability classification (nonirrigated): 8s

Hydrologic Soil Group: C

Minor Components

Massadona

Percent of map unit: 10 percent

Landform: Alluvial fans

Down-slope shape: Concave

Across-slope shape: Linear

Ro—Bebeever and Green River soils, and Riverwash, 0 to 2 percent slopes

Map Unit Setting

National map unit symbol: k0d4
Elevation: 4,430 to 4,820 feet
Mean annual precipitation: 7 to 10 inches
Mean annual air temperature: 50 to 54 degrees F
Frost-free period: 135 to 190 days
Farmland classification: Not prime farmland

Map Unit Composition

Bebeever and similar soils: 45 percent
Green river and similar soils: 35 percent
Riverwash: 20 percent
Estimates are based on observations, descriptions, and transects of the mapunit.

Description of Bebeever

Setting

Landform: Flood plains
Down-slope shape: Linear
Across-slope shape: Linear
Parent material: Alluvium over sandy and gravelly alluvium derived from sandstone and shale

Typical profile

Ap - 0 to 9 inches: loam
C1 - 9 to 14 inches: loam
C2 - 14 to 18 inches: fine sandy loam
2C - 18 to 32 inches: sand
3C - 32 to 59 inches: very cobbly sand

Properties and qualities

Slope: 0 to 2 percent
Depth to restrictive feature: More than 80 inches
Natural drainage class: Moderately well drained
Runoff class: Low
Capacity of the most limiting layer to transmit water (Ksat):
Moderately high to high (0.60 to 2.00 in/hr)
Depth to water table: About 24 to 48 inches
Frequency of flooding: Rare
Frequency of ponding: None
Calcium carbonate, maximum in profile: 5 percent
Salinity, maximum in profile: Nonsaline to very slightly saline (0.0 to 2.0 mmhos/cm)
Available water storage in profile: Low (about 4.7 inches)

Interpretive groups

Land capability classification (irrigated): 3s
Land capability classification (nonirrigated): 7s

Hydrologic Soil Group: C

Description of Green River

Setting

Landform: Flood plains, terraces

Landform position (three-dimensional): Tread

Down-slope shape: Linear

Across-slope shape: Linear

Parent material: Clayey alluvium over coarse-loamy alluvium derived from sandstone and shale

Typical profile

Ap - 0 to 10 inches: silty clay loam

C1 - 10 to 16 inches: fine sandy loam

C2 - 16 to 24 inches: fine sandy loam

C3 - 24 to 32 inches: fine sandy loam

C4 - 32 to 44 inches: fine sandy loam

C5 - 44 to 52 inches: fine sandy loam

2C - 52 to 60 inches: very cobbly sand

Properties and qualities

Slope: 0 to 2 percent

Depth to restrictive feature: More than 80 inches

Natural drainage class: Moderately well drained

Runoff class: Low

Capacity of the most limiting layer to transmit water (Ksat):

Moderately high (0.20 to 0.60 in/hr)

Depth to water table: About 24 to 48 inches

Frequency of flooding: Rare

Frequency of ponding: None

Calcium carbonate, maximum in profile: 5 percent

Salinity, maximum in profile: Very slightly saline to strongly saline
(2.0 to 16.0 mmhos/cm)

Sodium adsorption ratio, maximum in profile: 5.0

Available water storage in profile: Moderate (about 7.7 inches)

Interpretive groups

Land capability classification (irrigated): 2e

Land capability classification (nonirrigated): 7c

Hydrologic Soil Group: C

Description of Riverwash

Setting

Landform: Flood plains

Down-slope shape: Linear

Across-slope shape: Linear

Parent material: Sandy and gravelly alluvium

Typical profile

C1 - 0 to 6 inches: very gravelly sand

C2 - 6 to 60 inches: stratified extremely gravelly coarse sand to gravelly sand

Properties and qualities

Slope: 0 to 2 percent

Natural drainage class: Somewhat excessively drained

Runoff class: Low

Capacity of the most limiting layer to transmit water (Ksat): High to very high (6.00 to 20.00 in/hr)

Depth to water table: About 0 to 24 inches

Frequency of flooding: Frequent

Available water storage in profile: Very low (about 1.8 inches)

Interpretive groups

Land capability classification (irrigated): 6w

Land capability classification (nonirrigated): 7w

Hydrologic Soil Group: A

Data Source Information

Soil Survey Area: Mesa County Area, Colorado

Survey Area Data: Version 6, Sep 23, 2015

Roads and Streets, Shallow Excavations, and Lawns and Landscaping

Soil properties influence the development of building sites, including the selection of the site, the design of the structure, construction, performance after construction, and maintenance. This table shows the degree and kind of soil limitations that affect local roads and streets, shallow excavations, and lawns and landscaping.

The ratings in the table are both verbal and numerical. Rating class terms indicate the extent to which the soils are limited by all of the soil features that affect building site development. *Not limited* indicates that the soil has features that are very favorable for the specified use. Good performance and very low maintenance can be expected. *Somewhat limited* indicates that the soil has features that are moderately favorable for the specified use. The limitations can be overcome or minimized by special planning, design, or installation. Fair performance and moderate maintenance can be expected. *Very limited* indicates that the soil has one or more features that are unfavorable for the specified use. The limitations generally cannot be overcome without major soil reclamation, special design, or expensive installation procedures. Poor performance and high maintenance can be expected.

Numerical ratings in the table indicate the severity of individual limitations. The ratings are shown as decimal fractions ranging from 0.01 to 1.00. They indicate gradations between the point at which a soil feature has the greatest negative impact on the use (1.00) and the point at which the soil feature is not a limitation (0.00).

Local roads and streets have an all-weather surface and carry automobile and light truck traffic all year. They have a subgrade of cut or fill soil material; a base of gravel, crushed rock, or soil material stabilized by lime or cement; and a surface of flexible material (asphalt), rigid material (concrete), or gravel with a binder. The ratings are based on the soil properties that affect the ease of excavation and grading and the traffic-supporting capacity. The properties that affect the ease of excavation and grading are depth to bedrock or a cemented pan, hardness of bedrock or a cemented pan, depth to a water table, ponding, flooding, the amount of large stones, and slope. The properties that affect the traffic-supporting capacity are soil strength (as inferred from the AASHTO group index number), subsidence, linear extensibility (shrink-swell potential), the potential for frost action, depth to a water table, and ponding.

Shallow excavations are trenches or holes dug to a maximum depth of 5 or 6 feet for graves, utility lines, open ditches, or other purposes. The ratings are based on the soil properties that influence the ease of digging and the resistance to sloughing. Depth to bedrock or a cemented pan, hardness of bedrock or a cemented pan, the amount of large stones, and dense layers influence the ease of digging, filling, and compacting. Depth to the seasonal high water table, flooding, and ponding may restrict the period when excavations can be made. Slope influences the ease of using machinery. Soil texture, depth to the water table, and linear extensibility (shrink-swell potential) influence the resistance to sloughing.

Lawns and landscaping require soils on which turf and ornamental trees and shrubs can be established and maintained. Irrigation is not considered in the ratings. The ratings are based on the soil properties that affect plant growth and trafficability after vegetation is established. The properties that affect plant growth are reaction; depth to a water table; ponding; depth to bedrock or a cemented pan; the available water capacity in the upper 40 inches; the content of salts, sodium, or calcium carbonate; and sulfidic materials. The properties that affect trafficability are flooding, depth to a water table, ponding, slope, stoniness, and the amount of sand, clay, or organic matter in the surface layer.

Information in this table is intended for land use planning, for evaluating land use alternatives, and for planning site investigations prior to design and construction. The information, however, has limitations. For example, estimates and other data generally apply only to that part of the soil between the surface and a depth of 5 to 7 feet. Because of the map scale, small areas of different soils may be included within the mapped areas of a specific soil.

The information is not site specific and does not eliminate the need for onsite investigation of the soils or for testing and analysis by personnel experienced in the design and construction of engineering works.

Government ordinances and regulations that restrict certain land uses or impose specific design criteria were not considered in preparing the information in this table. Local ordinances and regulations should be considered in planning, in site selection, and in design.

Report—Roads and Streets, Shallow Excavations, and Lawns and Landscaping

[Onsite investigation may be needed to validate the interpretations in this table and to confirm the identity of the soil on a given site. The numbers in the value columns range from 0.01 to 1.00. The larger the value, the greater the potential limitation. The table shows only the top five limitations for any given soil. The soil may have additional limitations]

Roads and Streets, Shallow Excavations, and Lawns and Landscaping—Mesa County Area, Colorado							
Map symbol and soil name	Pct. of map unit	Local roads and streets		Shallow excavations		Lawns and landscaping	
		Rating class and limiting features	Value	Rating class and limiting features	Value	Rating class and limiting features	Value
BcS—Sagers silty clay loam, saline, 0 to 2 percent slopes							
Sagers, saline	90	Very limited		Somewhat limited		Very limited	
		Low strength	1.00	Dusty	0.50	Salinity	1.00
		Shrink-swell	0.50	Unstable excavation walls	0.01	Droughty	0.98
						Dusty	0.50

Roads and Streets, Shallow Excavations, and Lawns and Landscaping--Mesa County Area, Colorado							
Map symbol and soil name	Pct. of map unit	Local roads and streets		Shallow excavations		Lawns and landscaping	
		Rating class and limiting features	Value	Rating class and limiting features	Value	Rating class and limiting features	Value
Ro—Bebeever and Green River soils, and Riverwash, 0 to 2 percent slopes							
Bebeever	45	Somewhat limited		Very limited		Somewhat limited	
		Flooding	0.40	Unstable excavation walls	1.00	Dusty	0.19
				Depth to saturated zone	0.96		
				Dusty	0.19		
Green river	35	Somewhat limited		Somewhat limited		Somewhat limited	
		Flooding	0.40	Depth to saturated zone	0.96	Dusty	0.29
				Dusty	0.29	Salinity	0.13
				Unstable excavation walls	0.01		
Riverwash	20	Not rated		Not rated		Not rated	

Data Source Information

Soil Survey Area: Mesa County Area, Colorado
 Survey Area Data: Version 6, Sep 23, 2015

Soil Features

This table gives estimates of various soil features. The estimates are used in land use planning that involves engineering considerations.

A *restrictive layer* is a nearly continuous layer that has one or more physical, chemical, or thermal properties that significantly impede the movement of water and air through the soil or that restrict roots or otherwise provide an unfavorable root environment. Examples are bedrock, cemented layers, dense layers, and frozen layers. The table indicates the hardness and thickness of the restrictive layer, both of which significantly affect the ease of excavation. *Depth to top* is the vertical distance from the soil surface to the upper boundary of the restrictive layer.

Subsidence is the settlement of organic soils or of saturated mineral soils of very low density. Subsidence generally results from either desiccation and shrinkage, or oxidation of organic material, or both, following drainage. Subsidence takes place gradually, usually over a period of several years. The table shows the expected initial subsidence, which usually is a result of drainage, and total subsidence, which results from a combination of factors.

Potential for frost action is the likelihood of upward or lateral expansion of the soil caused by the formation of segregated ice lenses (frost heave) and the subsequent collapse of the soil and loss of strength on thawing. Frost action occurs when moisture moves into the freezing zone of the soil. Temperature, texture, density, saturated hydraulic conductivity (K_{sat}), content of organic matter, and depth to the water table are the most important factors considered in evaluating the potential for frost action. It is assumed that the soil is not insulated by vegetation or snow and is not artificially drained. Silty and highly structured, clayey soils that have a high water table in winter are the most susceptible to frost action. Well drained, very gravelly, or very sandy soils are the least susceptible. Frost heave and low soil strength during thawing cause damage to pavements and other rigid structures.

Risk of corrosion pertains to potential soil-induced electrochemical or chemical action that corrodes or weakens uncoated steel or concrete. The rate of corrosion of uncoated steel is related to such factors as soil moisture, particle-size distribution, acidity, and electrical conductivity of the soil. The rate of corrosion of concrete is based mainly on the sulfate and sodium content, texture, moisture content, and acidity of the soil. Special site examination and design may be needed if the combination of factors results in a severe hazard of corrosion. The steel or concrete in installations that intersect soil boundaries or soil layers is more susceptible to corrosion than the steel or concrete in installations that are entirely within one kind of soil or within one soil layer.

For uncoated steel, the risk of corrosion, expressed as *low*, *moderate*, or *high*, is based on soil drainage class, total acidity, electrical resistivity near field capacity, and electrical conductivity of the saturation extract.

For concrete, the risk of corrosion also is expressed as *low*, *moderate*, or *high*. It is based on soil texture, acidity, and amount of sulfates in the saturation extract.

Report—Soil Features

Soil Features—Mesa County Area, Colorado										
Map symbol and soil name	Restrictive Layer			Hardness	Subsidence		Potential for frost action	Risk of corrosion		
	Kind	Depth to top	Thickness		Initial	Total		Uncoated steel	Concrete	
		Low-RV-High	Range		Low-High	Low-High				
		In	In		In	In				
BcS—Sagers silty clay loam, saline, 0 to 2 percent slopes										
Sagers, saline		—	—		0	—	Low	High	High	
Ro—Bebevar and Green River soils, and Riverwash, 0 to 2 percent slopes										
Bebevar		—	—		0	—	Low	Moderate	Low	
Green river		—	—		0	—	Low	High	Moderate	
Riverwash		—	—		0	—	Low	High	Low	

Data Source Information

Soil Survey Area: Mesa County Area, Colorado
 Survey Area Data: Version 6, Sep 23, 2015



APPENDIX B
Typed Boring and Test Pit Logs



Huddlestone-Berry Engineering & Testing, LLC
 640 White Avenue, Unit B
 Grand Junction, CO 81501
 970-255-8005
 970-255-6818

BORING NUMBER B-1
 PAGE 1 OF 1

CLIENT Stantec	PROJECT NAME Persigo Outfall
PROJECT NUMBER 01543-0001	PROJECT LOCATION Grand Junction, CO
DATE STARTED 4/14/16 COMPLETED 4/20/16	GROUND ELEVATION 4520 ft HOLE SIZE _____
DRILLING CONTRACTOR S. McCracken	GROUND WATER LEVELS:
DRILLING METHOD Simco 2000 Truck Rig	▽ AT TIME OF DRILLING 10.5 ft / Elev 4509.5 ft
LOGGED BY CM CHECKED BY MAB	▼ AT END OF DRILLING 10.5 ft / Elev 4509.5 ft
NOTES _____	AFTER DRILLING ---

DEPTH (ft)	GRAPHIC LOG	MATERIAL DESCRIPTION	SAMPLE TYPE NUMBER	RECOVERY % (RQD)	BLOW COUNTS (N VALUE)	POCKET PEN. (tsf)	DRY UNIT WT. (pcf)	MOISTURE CONTENT (%)	ATTERBERG LIMITS			FINES CONTENT (%)
									LIQUID LIMIT	PLASTIC LIMIT	PLASTICITY INDEX	
0	ASPHALT	ASPHALT										
	Sandy GRAVEL (FILL), brown, moist dense	Sandy GRAVEL (FILL), brown, moist dense	SS 1	0	50							
5												
	Silty SAND with Gravel (sm), brown, moist to wet, medium dense	Silty SAND with Gravel (sm), brown, moist to wet, medium dense	SS 2	56	20-20-17 (37)							
10												
	Sandy GRAVEL and COBBLES (gw), brown, wet, dense	Sandy GRAVEL and COBBLES (gw), brown, wet, dense	SS 3	56	7-8-7 (15)							
15												
20		Bottom of hole at 22.0 feet.										

GEOTECH BH COLUMNS 01543-0001.GPJ GINT US LAB.GDT 10/3/17



Huddlestone-Berry Engineering & Testing, LLC
 640 White Avenue, Unit B
 Grand Junction, CO 81501
 970-255-8005
 970-255-6818

BORING NUMBER B-2

PAGE 1 OF 1

CLIENT <u>Stantec</u>	PROJECT NAME <u>Persigo Outfall</u>
PROJECT NUMBER <u>01543-0001</u>	PROJECT LOCATION <u>Grand Junction, CO</u>
DATE STARTED <u>4/14/16</u> COMPLETED <u>4/20/16</u>	GROUND ELEVATION <u>4514 ft</u> HOLE SIZE _____
DRILLING CONTRACTOR <u>S. McCracken</u>	GROUND WATER LEVELS:
DRILLING METHOD <u>Simco 2000 Truck Rig</u>	▽ AT TIME OF DRILLING <u>6.0 ft / Elev 4508.0 ft</u>
LOGGED BY <u>CM</u> CHECKED BY <u>MAB</u>	▼ AT END OF DRILLING <u>6.0 ft / Elev 4508.0 ft</u>
NOTES _____	AFTER DRILLING <u>---</u>

DEPTH (ft)	GRAPHIC LOG	MATERIAL DESCRIPTION	SAMPLE TYPE NUMBER	RECOVERY % (RQD)	BLOW COUNTS (N VALUE)	POCKET PEN. (tsf)	DRY UNIT WT. (pcf)	MOISTURE CONTENT (%)	ATTERBERG LIMITS			FINES CONTENT (%)
									LIQUID LIMIT	PLASTIC LIMIT	PLASTICITY INDEX	
0		Clayey SAND with Gravel (sc-sm), brown, moist, medium dense										
5		Sandy GRAVEL and COBBLES (gw), brown, moist to wet, dense	SS 1		14-22							
10												
15		SHALE, black, hard, highly weathered										
20		Bottom of hole at 20.0 feet.										

GEOTECH BH COLUMNS 01543-0001.GPJ GINT US LAB.GDT 10/3/17



Huddlestone-Berry Engineering & Testing, LLC
 640 White Avenue, Unit B
 Grand Junction, CO 81501
 970-255-8005
 970-255-6818

BORING NUMBER B-3

PAGE 1 OF 1

CLIENT <u>Stantec</u>	PROJECT NAME <u>Persigo Outfall</u>
PROJECT NUMBER <u>01543-0001</u>	PROJECT LOCATION <u>Grand Junction, CO</u>
DATE STARTED <u>4/14/16</u> COMPLETED <u>4/20/16</u>	GROUND ELEVATION <u>4521 ft</u> HOLE SIZE _____
DRILLING CONTRACTOR <u>S. McKracken</u>	GROUND WATER LEVELS:
DRILLING METHOD <u>Simco 2000 Track Rig</u>	▽ AT TIME OF DRILLING <u>14.5 ft / Elev 4506.5 ft</u>
LOGGED BY <u>CM</u> CHECKED BY <u>MAB</u>	▼ AT END OF DRILLING <u>14.5 ft / Elev 4506.5 ft</u>
NOTES _____	AFTER DRILLING <u>---</u>

DEPTH (ft)	GRAPHIC LOG	MATERIAL DESCRIPTION	SAMPLE TYPE NUMBER	RECOVERY % (RQD)	BLOW COUNTS (N VALUE)	POCKET PEN. (tsf)	DRY UNIT WT. (pcf)	MOISTURE CONTENT (%)	ATTERBERG LIMITS			FINES CONTENT (%)
									LIQUID LIMIT	PLASTIC LIMIT	PLASTICITY INDEX	
0	ASPHALT											
	Sandy GRAVEL (FILL), brown, moist dense		SS 1	67	17-17-26 (43)							
5												
10	Sandy GRAVEL and COBBLES (gw), brown, moist to wet, dense		SS 2	75	20-25							
15	▼		SS 3	61	15-18-21 (39)							
20												
		Bottom of hole at 23.0 feet.										

GEOTECH BH COLUMNS 01543-0001.GPJ GINT US LAB.GDT 10/3/17



Huddlestone-Berry Engineering & Testing, LLC
 640 White Avenue, Unit B
 Grand Junction, CO 81501
 970-255-8005
 970-255-6818

BORING NUMBER B-4

PAGE 1 OF 1

CLIENT <u>Stantec</u>	PROJECT NAME <u>Persigo Outfall</u>
PROJECT NUMBER <u>01543-0001</u>	PROJECT LOCATION <u>Grand Junction, CO</u>
DATE STARTED <u>4/14/16</u> COMPLETED <u>4/20/16</u>	GROUND ELEVATION <u>4512 ft</u> HOLE SIZE _____
DRILLING CONTRACTOR <u>S. McCracken</u>	GROUND WATER LEVELS:
DRILLING METHOD <u>Simco 2000 Truck Rig</u>	▽ AT TIME OF DRILLING <u>5.0 ft / Elev 4507.0 ft</u>
LOGGED BY <u>CM</u> CHECKED BY <u>MAB</u>	▼ AT END OF DRILLING <u>5.0 ft / Elev 4507.0 ft</u>
NOTES _____	AFTER DRILLING <u>---</u>

DEPTH (ft)	GRAPHIC LOG	MATERIAL DESCRIPTION	SAMPLE TYPE NUMBER	RECOVERY % (RQD)	BLOW COUNTS (N VALUE)	POCKET PEN. (tsf)	DRY UNIT WT. (pcf)	MOISTURE CONTENT (%)	ATTERBERG LIMITS			FINES CONTENT (%)
									LIQUID LIMIT	PLASTIC LIMIT	PLASTICITY INDEX	
0		Silty SAND (sm), brown, moist to wet, very loose										
5	▼		MC 1	89	3-1-2 (3)							
10			SS 1	67	0-1-1 (2)							
15		Sandy GRAVEL and COBBLES (gw), brown, wet, dense	SS 2	83	15-30							
20		SHALE, black, hard, highly weathered										
		Bottom of hole at 20.0 feet.										

GEOTECH BH COLUMNS 01543-0001.GPJ GINT US LAB.GDT 10/3/17



Huddlestone-Berry Engineering & Testing, LLC
 640 White Avenue, Unit B
 Grand Junction, CO 81501
 970-255-8005
 970-255-6818

BORING NUMBER B-5

PAGE 1 OF 1

CLIENT <u>Stantec</u>	PROJECT NAME <u>Persigo Outfall</u>
PROJECT NUMBER <u>01543-0001</u>	PROJECT LOCATION <u>Grand Junction, CO</u>
DATE STARTED <u>4/14/16</u> COMPLETED <u>4/14/16</u>	GROUND ELEVATION <u>4516 ft</u> HOLE SIZE _____
DRILLING CONTRACTOR <u>S. McCracken</u>	GROUND WATER LEVELS:
DRILLING METHOD <u>Simco 2000 Truck Rig</u>	▽ AT TIME OF DRILLING <u>8.0 ft / Elev 4508.0 ft</u>
LOGGED BY <u>CM</u> CHECKED BY <u>MAB</u>	▼ AT END OF DRILLING <u>8.0 ft / Elev 4508.0 ft</u>
NOTES _____	AFTER DRILLING <u>---</u>

DEPTH (ft)	GRAPHIC LOG	MATERIAL DESCRIPTION	SAMPLE TYPE NUMBER	RECOVERY % (RQD)	BLOW COUNTS (N VALUE)	POCKET PEN. (tsf)	DRY UNIT WT. (pcf)	MOISTURE CONTENT (%)	ATTERBERG LIMITS			FINES CONTENT (%)
									LIQUID LIMIT	PLASTIC LIMIT	PLASTICITY INDEX	
0		Sandy GRAVEL and COBBLES (gw), brown, moist to wet, medium dense to dense										
5			SS 1	11	10-12-10 (22)							
10												
15												
		Bottom of hole at 16.0 feet.										

GEOTECH BH COLUMNS 01543-0001.GPJ GINT US LAB.GDT 10/3/17



Huddleston-Berry Engineering & Testing, LLC
 640 White Avenue, Unit B
 Grand Junction, CO 81501
 970-255-8005
 970-255-6818

TEST PIT NUMBER TP-1

PAGE 1 OF 1

CLIENT Stantec	PROJECT NAME Persigo Outfall
PROJECT NUMBER 01543-0001	PROJECT LOCATION Grand Junction, CO
DATE STARTED 9/12/17 COMPLETED 9/12/17	GROUND ELEVATION 4514 ft TEST PIT SIZE _____
EXCAVATION CONTRACTOR Client	GROUND WATER LEVELS:
EXCAVATION METHOD Trackh/Backhoe	▽ AT TIME OF EXCAVATION 9.0 ft / Elev 4505.0 ft
LOGGED BY CM CHECKED BY MAB	▼ AT END OF EXCAVATION 9.0 ft / Elev 4505.0 ft
NOTES _____	AFTER EXCAVATION ---

DEPTH (ft)	GRAPHIC LOG	MATERIAL DESCRIPTION	SAMPLE TYPE NUMBER	RECOVERY % (RQD)	BLOW COUNTS (N VALUE)	POCKET PEN. (tsf)	DRY UNIT WT. (pcf)	MOISTURE CONTENT (%)	ATTERBERG LIMITS			FINES CONTENT (%)
									LIQUID LIMIT	PLASTIC LIMIT	PLASTICITY INDEX	
0.0		Gravelly CLAY with Cobbles (FILL), brown, moist, very dense										
2.5		Clayey SAND with Gravel (sc-sm), brown, moist, medium dense										
5.0		Sandy GRAVEL and COBBLES (gw), brown, moist to wet, dense										
7.5		*** A few 12" particles were observed										
10.0			GB 1						NP	NP	NP	1
12.5			GB 1						NP	NP	NP	2
		Bottom of test pit at 13.0 feet.										

GEOTECH BH COLUMNS 01543-0001.GPJ GINT US LAB.GDT 10/10/17



Huddlestone-Berry Engineering & Testing, LLC
 640 White Avenue, Unit B
 Grand Junction, CO 81501
 970-255-8005
 970-255-6818

TEST PIT NUMBER TP-2

PAGE 1 OF 1

CLIENT <u>Stantec</u>	PROJECT NAME <u>Persigo Outfall</u>
PROJECT NUMBER <u>01543-0001</u>	PROJECT LOCATION <u>Grand Junction, CO</u>
DATE STARTED <u>9/12/17</u> COMPLETED <u>9/12/17</u>	GROUND ELEVATION <u>4514 ft</u> TEST PIT SIZE _____
EXCAVATION CONTRACTOR <u>Client</u>	GROUND WATER LEVELS:
EXCAVATION METHOD <u>Trackh/Backhoe</u>	▽ AT TIME OF EXCAVATION <u>8.0 ft / Elev 4506.0 ft</u>
LOGGED BY <u>CM</u> CHECKED BY <u>MAB</u>	▼ AT END OF EXCAVATION <u>8.0 ft / Elev 4506.0 ft</u>
NOTES _____	AFTER EXCAVATION <u>---</u>

DEPTH (ft)	GRAPHIC LOG	MATERIAL DESCRIPTION	SAMPLE TYPE NUMBER	RECOVERY % (RQD)	BLOW COUNTS (N VALUE)	POCKET PEN. (tsf)	DRY UNIT WT. (pcf)	MOISTURE CONTENT (%)	ATTERBERG LIMITS			FINES CONTENT (%)
									LIQUID LIMIT	PLASTIC LIMIT	PLASTICITY INDEX	
0.0		Clayey SAND with Organics (TOPSOIL)										
2.5		Clayey SAND with Gravel (sc-sm), brown, moist, medium dense										
7.5		Sandy GRAVEL and COBBLES (gw), brown, moist to wet, dense *** A few 12" particles were observed	GB 1						NP	NP	NP	4
10.0		Bottom of test pit at 10.0 feet.										

GEOTECH BH COLUMNS 01543-0001.GPJ GINT US LAB.GDT 10/10/17

APPENDIX C
Laboratory Testing Results



Huddlestone-Berry Engineering & Testing, LLC
 640 White Avenue, Unit B
 Grand Junction, CO 81501
 970-255-8005
 970-255-6818

GRAIN SIZE DISTRIBUTION

CLIENT Stantec

PROJECT NAME Persigo Outfall

PROJECT NUMBER 01543-0001

PROJECT LOCATION Grand Junction, CO

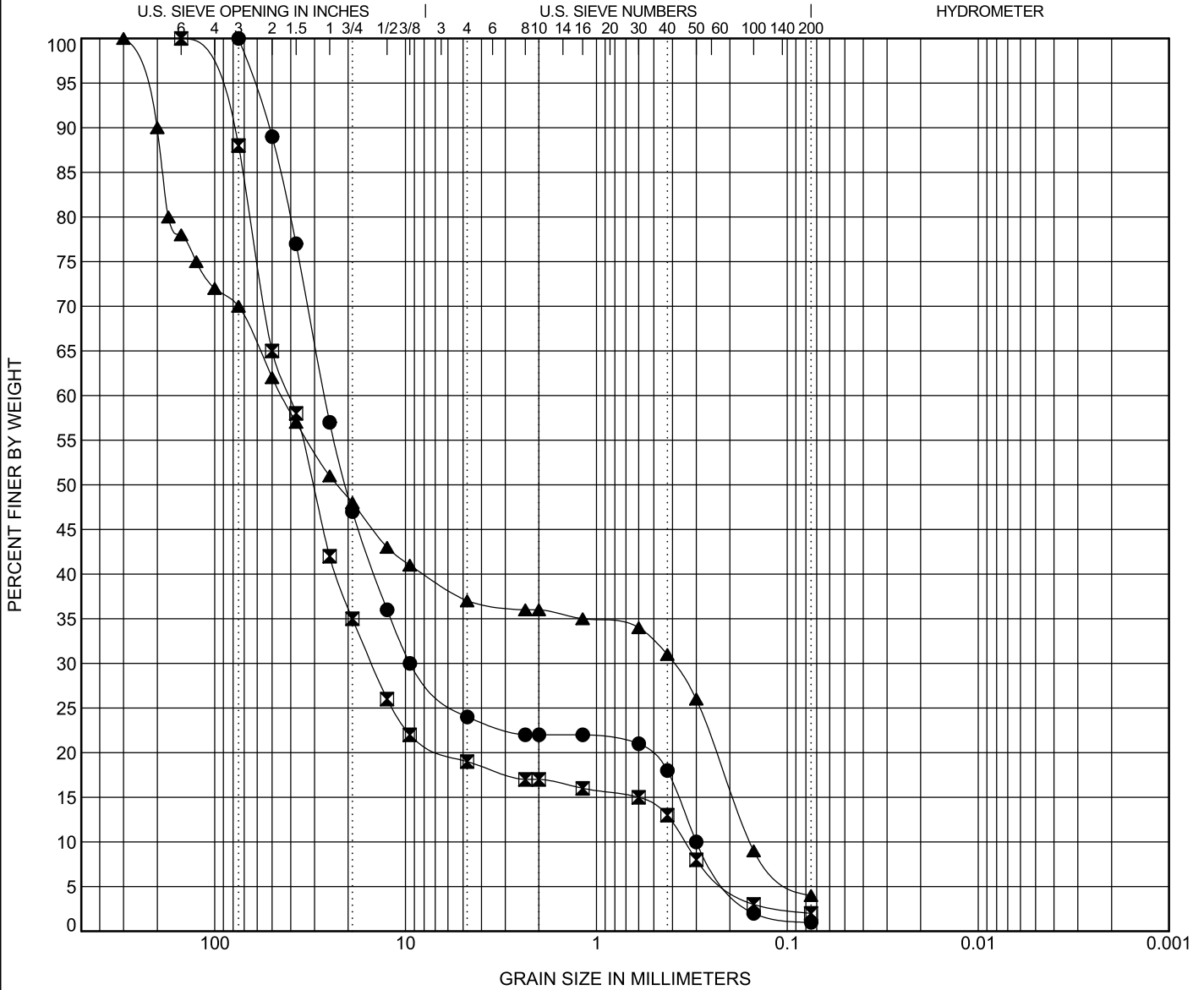



PHYSICAL PROPERTIES AND COMPRESSIVE STRENGTH TEST REPORT

Task / Material Tested: Rock Cores

Project No.: 01543 - 0001 **Authorized By:** Client **Date:** 09/12/17
Project Name: Persigo Outfall **Sampled By:** CM **Date:** 09/12/17
Client Name: Stantec **Work Order No.:** _____
General Contractor: _____ **Picked Up By:** _____ **Date:** _____
Placement Contractor: _____ **Work Order No.:** _____
Contractor Representative: _____ **Reviewed By:** MAB **Date:** 10/09/17
Location of Placement: _____

Sample Location: _____
Cylinder Storage Location: _____
Weather Conditions: _____ **Ambient Temperature (°F):** _____

Number of Samples Casted/Molded

Concrete: 4 *Grout Cyl: 0 **Grout Prism: 0 Mortar Cyl: 0 Mortar Cube: 0 Soils: 0

Mix Data	Specifications	Measured Properties
Supplier: _____	Temp., C1064 (deg. F): _____	Temp., C1064 (deg. F): _____
Mix ID/Brand: _____	Slump, C143 (in.): _____	Slump, C143 (in.): _____
Ticket No.: _____	Air Content, C231 (%): _____	Air Cont., C231 (%): _____
Batch Time (MIL): _____	*Flow Rate: _____	*Flow Rate: _____
Sample Time (MIL): _____	Unit Weight, C138 (pcf): _____	Unit Weight, C138 (pcf): _____
Water Added (gal.): _____	Time in Mixer (min): _____	Time in Mixer (min): _____
Load Number: _____ of _____	Additional Water (gal.): _____	Mold Dims: <u>2X4</u>
Initial W:C Ratio: _____	Max W:C Ratio: _____	Final W:C Ratio: _____
Batch Size: _____	Compressive Str. (psi): _____	Avg. Cap Thickness, C42: _____

Tare Volume (cf): _____ Tare Weight (lbs): _____ Tare & Concrete Weight (lbs): _____
 Soil Weight (gm): _____ Admixture Weight (gm): _____ Admixture Percent (%): _____ Moisture Content (%): _____

Sample No.	Break Date	Age (days)	Avg. Dia. (in.)	Avg. Hght. (in.)	Avg. Area (in.)	Weight (g)	Unit Wt. (pcf)	Break Information, C39					
								Cap*	Load (lbs)	Strength (psi)	(psi) Ratio	Break Type	Tech.

CONCRETE FIELD CURES (if applicable), Cores, Grout Prisms, or Mortar Cubes

1	10/12/17		1.93	3.96	2.93	409	134.5	S	26015	8890		4	TH
2	10/12/17		1.93	3.96	2.93	474	155.8	S	39640	13550		4	TH
3	10/12/17		1.94	3.99	2.96	396	127.8	S	34005	11500		4	TH
4	10/12/17		1.93	3.86	2.93	375	126.7	S	43830	14980		4	TH
5	10/12/17		1.94	3.94	2.94	473	155.4	S	40535	13770		4	TH

Cap Type*: S=Sulfur G=Gypsum C=Neat Cement U=Unbonded Neoprene O=None

Remarks: _____

Field Set Number: _____ of _____ *Flow Cone No.: _____ Compression Machine: F-502
 Field Scale No.: _____ **Cube Mold No.: _____ Lab Scale: L129

Building Permit Number: _____ **Record No.** C

SPECIFICATIONS

TABLE OF CONTENTS

<u>SECTION</u>	<u>TITLE</u>	<u>PAGES</u>
<u>CONTRACT DOCUMENTS</u>		
<u>REFERENCED SPECIFICATIONS</u>		
107.25	CDOT Water Quality Control	107.25-131:107.25-140
201	CDOT Clearing and Grubbing	201.02-179:201.02-180
202	CDOT Removal of Structures and Obstructions	202.02-181:202.12-187
207	CDOT Topsoil	207.01-214:207.05-215
208	CDOT Erosion Control	208.01-216:208.12-246
210	CDOT Reset Structures	210.04-249:210.13-252
212	CDOT Seeding, Fertilizer, Soil Conditioner and Sodding	212.02-253:212.08-260
213	CDOT Mulching	213.02-261:213.05-269
214	CDOT Planting	214.02-270:214.06-277
216	CDOT Soil Retention Covering	216.02-282:216.08-289
250	CDOT Environmental, Health and Safety Management	250.01-292:250.10-310
506	CDOT Riprap	506.01-412:506.10-416
603	CDOT Culverts and Sewers	603.04-547:603.13-552
604	CDOT Manholes, Inlets, and Meter Vaults	604.04-553:604.07-555
607	CDOT Fences	607.03-565:607.05-567
705	CDOT Joint, Waterproofing, and Bearing Material	705.06-783:705.10-789
706	CDOT Concrete and Clay Pipe	706.01-790:706.07-791
712.13	CDOT Plastic Pipe	712.10-814:712.13-816
<u>SPECIFICATIONS</u>		
<u>DIVISION 1 GENERAL REQUIREMENTS</u>		
01010	Summary of Work	01010-1:01010-2
01016	Maintenance of Operation	01016-1:01016-2
01025	Measurement and Payment	01025-1:01025-11
01040	Coordination	01040-1:01040-2
01070	Abbreviations	01070-1:01070-5
01130	Dewatering	01130-1:01130-4
01310	Construction Schedule	01310-1:01310-3
01340	Shop Drawings, Samples, and Operation and Maintenance Manuals	01340-1:01340-7
01370	Schedule of Values	01370-1:01370-2
01700	Contract Closeout	01700-1:01700-1
01711	Site Cleanup	01711-1:01711-1
01740	Warranties	01740-1:01740-2
01782	Project Record Documents	01720-1:01720-2
<u>DIVISION 2 SITEWORK</u>		
02110	Site Clearing	02110-1:02110-2
02210	Demolition and Abandon Pipe	02210-1:02210-2
02220	Selective Site Demolition	02220-1:02220-2

DIVISION 2 SITEWORK (CONT)

02297	Disposal of Excavated Materials	02297-1:02297-1
02300	Earthwork and Trenching	02300-1:02300-14
02315	Steel Casing Pipe	02315-1:02315-4
02316	Pipe Ramming	02316-1:02316-14
02356	Steel Sheet Piling	02356-1:02356-12
02419	Selective Structure Demolition	02419-1:02419-2
02440	Pipe Jacking	02440-1:02440-19
02445	Instrumentation and Monitoring	02440-1:02440-19
02503	Aggregate Surfacing and Base Courses for Roads	02503-1:02503-4
02621	Shaft Construction	02621-1:02612-13
02623	Microtunneling	02623-1:02612-29
02715	Carrier Pipe Installation	02715-1:02715-11
02934	Soil Preparation	02934-1:02934-3
02395	Seeding	02395-1:02935-4

DIVISION 3 CONCRETE

03100	Concrete Formwork	03100-1:03100-5
03200	Concrete Reinforcement	03200-1:03200-4
03300	Cast-in-Place Concrete	03300-1:03300-18
03360	Contact Grouting	03300-1:03300-6
03600	Grout	03600-1:03600-4
03610	Ground Pre-Treatment	03610-1:03610-13

DIVISION 4 MASONRY

NOT USED

DIVISION 5 METALS

05550	Anchor Bolts and Expansion Anchors	05550-1:05550-3
-------	------------------------------------	-----------------

DIVISION 6 WOOD AND PLASTIC

NOT USED

DIVISION 7 THERMAL AND MOISTURE PROTECTION

NOT USED

DIVISION 7 THERMAL AND MOISTURE PROTECTION (CONTINUED)

NOT USED

DIVISION 8 DOORS AND WINDOWS

NOT USED

DIVISION 9 FINISHES

NOT USED

DIVISION 10 SPECIALTIES

NOT USED

SECTION	TITLE	PAGES
DIVISION 11 EQUIPMENT		
11001	Wide-bill Duckbill Diffuser	11001-1:11001-4
DIVISION 12 FURNISHINGS		
NOT USED		
DIVISION 13 SPECIAL CONSTRUCTION		
NOT USED		
DIVISION 14 CONVEYING SYSTEMS		
NOT USED		
DIVISION 15 MECHANICAL		
15064	High Density Polyethylene (HDPE) Pipe	15064-1:15064-3
DIVISION 16 ELECTRICAL		
NOT USED		
DIVISION 17 INSTRUMENTATION AND CONTROLS		
NOT USED		
<u>PERMIT INFORMATION</u>		
	US Army Corps of Engineers 404 Permit	1-3

REFERENCED SPECIFICATIONS

107.25 Water Quality Control. The project work shall be performed using practices that minimize water pollution during construction. All the practices listed in (b) below shall be followed to minimize the pollution of any State waters, including wetlands.

(a) *Definitions.*

1. Areas of Disturbance (AD). Locations where any activity has altered the existing soil cover or topography, including vegetative and non-vegetative activities during construction.
2. Construction Site Boundary/Limits of Construction (LOC). The project area defined by the Stormwater Construction Permit.
3. Discharge of Pollutants. One or more pollutants leaving the LOC or entering State waters or other conveyances.
4. Limits of Disturbed Area (LDA). Proposed limits of ground disturbance as shown on the Plans.
5. Pollutant. Dredged spoil, dirt, slurry, solid waste, incinerator residue, sewage, sewage sludge, garbage, trash, chemical waste, biological nutrient, biological material, radioactive material, heat, wrecked or discarded equipment, rock, sand, or any industrial, municipal, or agricultural waste, as defined in the Colorado Code of Regulations (CCR) [5 CCR 1002-61, 2(76)]
6. Pollution. Man-made, man-induced, or natural alteration of the physical, chemical, biological, and radiological integrity of water. [25-8-103 (16), CRS]
7. State waters. Defined in subsection 101.77.

(b) *Construction Requirements.*

1. The Contractor shall comply with the “Colorado Water Quality Control Act” (Title 25, article 8, CRS), the “Protection of Fishing Streams” (Title 33, Article 5, CRS), the “Clean Water Act” (33 USC 1344), regulations promulgated, certifications or permits issued, and to the requirements listed below. In the event of conflicts between these requirements and water quality control laws, rules, or regulations of other Federal, or State agencies, the more restrictive laws, rules, or regulations shall apply.
2. If the Contractor determines construction of the project will result in a change to the permitted activities or LDA, the Contractor shall detail the changes in a written report to the Engineer. Within five days after receipt of the report, the Engineer, after coordination with Region Planning and Environmental Manager (RPEM), will approve or reject in writing the request for change, or detail a course of action including revision of existing permits or obtaining new permits.
3. If construction activities result in noncompliance of any permit requirement, the project will be suspended and the permitting agency notified, if required. The project will remain suspended until the Engineer receives written approval by the permitting agency.
4. The Contractor is legally required to obtain all permits associated with specific activities within, or off the Right of Way, such as borrow pits, concrete or asphalt plant sites, waste disposal sites, or other facilities. It is

the Contractor's responsibility to obtain these permits. The Contractor shall consult with the Engineer, and contact the Colorado Department of Public Health and Environment (CDPHE) or other appropriate federal, state, or local agency to determine the need for any permit.

5. The Contractor shall conduct the work in a manner that prevents pollution of any adjacent State waters. Erosion control work shall be performed in accordance with Section 208, this subsection, and all other applicable parts of the Contract.
6. Prior to the Environmental Pre-construction Conference the SWMP Administrator, identified in subsection 208.03(c), shall identify and describe all potential pollutant sources, including materials and activities, and evaluate them for the potential to contribute pollutants to stormwater discharges associated with construction activities. The list of potential pollutants shall be continuously updated during construction. At a minimum, each of the following shall be evaluated for the potential for contributing pollutants to stormwater discharges and identified in the SWMP, if found to have such potential:
 - (1) All exposed and stored soils.
 - (2) Vehicle tracking of sediments.
 - (3) Management of contaminated soils.
 - (4) Vehicle and equipment maintenance and fueling.
 - (5) Outdoor storage activities (building materials, fertilizers, chemicals, etc.).
 - (6) Significant dust or particle generating processes.
 - (7) Routine maintenance involving fertilizers, pesticides, detergents, fuels, solvents, oils, etc.
 - (8) On site waste management practices (waste piles, dumpsters, etc.).
 - (9) Dedicated asphalt and concrete batch plants.
 - (10) Concrete truck and equipment washing, including the concrete truck chute and associated fixtures and equipment.
 - (11) Concrete placement and finishing tool cleaning.
 - (12) Non-industrial waste sources that may be significant, such as worker trash and portable toilets.
 - (13) Loading and unloading operations.
 - (14) Other areas or procedures where spills could occur.

The SWMP Administrator shall record the location of potential pollutants on the site map. Descriptions of the potential pollutants shall be added to the SWMP notebook.

At or prior to the Environmental Pre-construction Conference the Contractor shall submit a Spill Response Plan for any petroleum products, chemicals, solvents, or other hazardous materials in use, or in storage, at the work site. See subsection 208.06(c) for Spill Response Plan requirements. Work shall not be started until the plan has been submitted to and approved by the Engineer.

On site above ground bulk storage containers with a cumulative storage shell capacity greater than 1,320 U.S. gallons, or storage containers having a “reasonable expectation of an oil discharge” to State waters, are subject to the Spill Prevention, Control and Countermeasure Plan (SPCC) Rule. Oil of any type and in any form is covered, including, but not limited to: petroleum; fuel oil; sludge; oil refuse; oil mixed with wastes other than dredged spoil. EPA Region 8 is responsible for administering and enforcing the SPCC plan requirements in Colorado. Prior to start of work, the Contractor shall submit a SPCC Form which has been approved by the EPA for the project.

7. The Contractor shall obtain a Construction Dewatering (CDW) permit from CDPHE anytime uncontaminated groundwater, including groundwater that is commingled with stormwater or surface water, is encountered during construction activities and the groundwater or commingled water needs to be discharged to State waters. If contaminated groundwater is encountered, a Remediation permit may be needed from CDPHE in accordance with Section 250.
8. Water from dewatering operations shall not be directly discharged into any State waters, unless allowed by a permit. Water from dewatering shall not be discharged into a ditch unless:
 - (1) Written permission is obtained from the owner of the ditch.
 - (2) It is covered in the approved CDW or Remediation Permit that allows the discharge.
 - (3) A copy of this approval is submitted to the Engineer. A copy of the Permit shall be submitted to the Engineer prior to dewatering operations commencing.

If the site is covered by a Colorado Discharge Permit System Stormwater Construction Permit (CDPS-SCP) and the following conditions are met, a separate CDW permit will not be required for discharge to the ground:

- (1) The source is identified in the Stormwater Management Plan (SWMP) as updated by the SWMP Administrator.
- (2) The SWMP describes and locates the practices implemented at the site to control stormwater pollution from the dewatering of groundwater or stormwater.
- (3) The SWMP describes and locates the practices to be used that will ensure that no groundwater from construction dewatering is discharged from the LOC as surface runoff or to surface waters or storm sewers.

- (4) Groundwater and groundwater combined with stormwater do not contain pollutants in concentrations exceeding the State groundwater standards in Regulations 5 CCR 1002-41 and 42.

If surface waters are diverted around a construction area and no pollutants are introduced during the diversion, a CDW Permit is not required. If the diverted water enters the construction area and contacts pollutant sources (e.g. disturbed soil, concrete washout, etc.), the Contractor shall obtain a CDW permit for the discharge of this water to State waters or to the ground.

Construction Dewatering may be discharged to the ground on projects that are not covered by a CDPS-SCP if the conditions of the CDPHE's low risk guidance document for Discharges of Uncontaminated Groundwater to Land are met. The conditions of this guidance are:

- (1) The source of the discharge is solely uncontaminated groundwater or uncontaminated groundwater combined with stormwater and does not contain pollutants in concentrations that exceed water quality standards for groundwater referenced above.
- (2) Discharges from vaults or similar structures shall not be contaminated. Potential sources of contamination include process materials used, stored, or conveyed in the structures, or introduced surface water runoff from outside environments that may contain oil, grease, and corrosives.
- (3) The groundwater discharge does not leave the project boundary limits where construction is occurring.
- (4) Land application is conducted at a rate and location that does not allow for any runoff into State waters or other drainage conveyance systems, including but not limited to streets, curb and gutter, inlets, borrow ditches, open channels, etc.
- (5) Land application is conducted at a rate that does not allow for any ponding of the groundwater on the surface, unless the ponding is a result of implementing BMPs that are designed to reduce velocity flow. If the BMPs used result in ponding, the land application shall be done in an area with a constructed containment, such as an excavation or berm area with no outfall. The constructed containment shall prevent the discharge of the ponding water offsite as runoff.
- (6) A visible sheen is not evident in the discharge.
- (7) BMPs are implemented to prevent any sediment deposited during land application from being transported by stormwater runoff to surface waters or other conveyances.
- (8) All BMPs used shall be selected, installed, implemented, and maintained according to good Engineering, hydrologic and pollution control practices. The selected BMPs shall provide control for all potential pollutant sources associated with the discharge of uncontaminated groundwater to land. The discharge shall be routed

in such a way that it will not cause erosion to land surface. Energy dissipation devices designed to protect downstream areas from erosion by reducing the velocity of flow (such as hose attachments, sediment and erosion controls) shall be used when necessary to prevent erosion.

Discharged water shall be drained slowly so that it soaks into the ground without running outside the project boundary or causing flooding issues. The discharge shall be routed in such a way that it will not contact petroleum products or waste.

9. At least 15 days prior to commencing dredging or fill operations in a watercourse, the Contractor shall provide written notification to owners or operators of domestic or public water supply intakes or diversion facilities, if these facilities are within 20 miles downstream from the dredging or fill operations. Notification shall also be given to Owners or operators of other intakes or diversions that are located within five miles downstream from the site of the project. Identities of downstream owners and operators can be obtained from Colorado Division of Water Resources, Office of the State Engineer.
10. Temporary fill into wetlands or streams will not be allowed, except as specified in the Contract and permits. If such work is allowed, upon completion of the work all temporary fills shall be removed in their entirety and disposed of in an upland location outside of flood plains unless otherwise specified in the Contract.
11. Construction operations in waters of the United States as defined in 33 CFR Part 328.3, including wetlands, shall be restricted to areas and activities authorized by the U.S. Army Corps of Engineers as shown in the Contract. Foraging waters will be allowed only as authorized by the U.S. Army Corps of Engineers 404 Permit.
12. Wetland areas outside of the permitted limits of disturbance shall not be used for storage, parking, waste disposal, access, borrow material, or any other construction support activity.
13. Pollutant byproducts of highway construction, such as concrete, asphalt, solids, sludges, pollutants removed in the course of treatment of wastewater, excavation or excess fill material, and material from sediment traps shall be handled, stockpiled, and disposed of in a manner that prevents entry into State waters, including wetlands. Removal of concrete waste and washout water from mixer trucks, concrete finishing tools, concrete saw and all concrete material removed in the course of construction operations or cleaning shall be performed in a manner that prevents waste material from entering State waters. A minimum of ten days prior to the start of the construction activity, the Contractor shall submit in writing a Method Statement for Containing Pollutant Byproducts to the Engineer for approval.
14. The use of chemicals such as soil stabilizers, dust palliatives, herbicides, growth inhibitors, fertilizers, deicing salts, etc., shall be in accordance

with the manufacturer's recommended application rates, frequency, and instructions.

15. All materials stored on-site shall be stored in a neat, orderly manner, in their original containers, with the original manufacturer's label. Materials shall not be stored in a location where they may be carried into State waters at any time.
 16. Spill prevention and containment measures conforming to subsection 208.06 shall be used at storage, and equipment fueling and servicing areas to prevent the pollution of any State waters, including wetlands. All spills shall be cleaned up immediately after discovery, or contained until appropriate cleanup methods can be employed. Manufacturer's recommended methods for spill cleanup shall be followed, along with proper disposal methods. When required by the Colorado Water Quality Control Act, Regulation 5 CCR 1002-61, spills shall be reported to the Engineer and CDPHE in writing.
 17. The Contractor shall prevent construction activities from causing grass or brush fires.
 18. The construction activities shall not impair Indian tribal rights, including, but not limited to, water rights, and treaty fishing and hunting rights.
 19. Prior to start of work, the Contractor shall certify in writing to the Engineer that construction equipment has been cleaned prior to initial site arrival. Vehicles and equipment shall be free of soil and debris capable of transporting noxious weed seeds or invasive species onto the site. Additional equipment required for construction shall also be certified prior to being brought onto the project site.
 20. Vehicles which have been certified by the Contractor as having been cleaned prior to arrival on site may be cleaned on site at an approved area where wash water can be properly contained. Vehicles leaving and reentering the project site shall be recertified.
 21. At the end of each day the Contractor shall collect all trash and dispose of it in appropriate containers.
 22. Construction waste that is considered a pollutant or contaminant shall be collected and disposed of in appropriate containers. This material may be stockpiled on the project when it is contained or protected by an appropriate BMP.
- (c) *Stormwater Construction Permit.* A Colorado Discharge Permit System Stormwater Construction Permit (CDPS-SCP) shall be obtained from CDPHE by either the Contractor or CDOT. The Contract will clearly indicate whether the permit is to be obtained by the Contractor or CDOT.
1. *Contractor Obtained Stormwater Construction Permit.* The Contractor shall obtain a Colorado Discharge Permit System Stormwater Construction Permit (CDPS-SCP) for any project work that disturbs at least 1 acre of land. The Contractor shall apply for and obtain the permit

upon award of the Contract. The Contractor shall provide a copy of permit certification or the submitted CDPS-SCP application to the Engineer prior to or at the Pre-construction Conference. No work shall begin until the CDPS-SCP permit has been approved by CDPHE, unless otherwise directed. A copy of the Permit and application to obtain a permit shall be placed in the project SWMP notebook.

If a Utility Company has obtained a permit for the area prior to the Contractor being on site, then the Contractor shall coordinate with the Utility Company to transfer those areas over to the Contractor prior to work commencing. The Contractor shall not commence construction until Application for Transfer of Ownership for All Permits, Certifications and Authorizations has been approved by CDPHE and submitted to the Engineer.

To initiate partial acceptance of the stormwater construction work (including seeding and planting required for erosion control), the Contractor shall request in writing a Stormwater Completion Walkthrough. The Engineer will set up the walkthrough and will include: the Engineer or designated representative, Superintendent or designated representative, Stormwater Management Plan (SWMP) Administrator, Region Water Pollution Control Manager (RWPCM) and Landscape Architect representing the region. Unsatisfactory and incomplete erosion control work will be identified in this walkthrough, and will be summarized by the Engineer in a punch list. The Water Quality Permit Transfer to Maintenance Punch List may be used as a template in creating the Engineer's punch list.

The Engineer will coordinate with CDOT Maintenance on regular inspections of the corrective work. The completed action items associated with the corrective work shall be shown as completed on the Punch List. Upon completion of all items shown, the Contractor shall submit the completed Punch List to the Engineer for review. Upon written approval of the Punch List, the Contractor shall submit the "Application for Transfer of Ownership for All Permits, Certifications and Authorizations" to the CDPHE requesting transfer of ownership of the CDPS-SCP to CDOT Maintenance. When requested by CDOT Maintenance and approved by the Engineer, the Permit may be transferred by the Contractor to the Resident Engineer instead of CDOT Maintenance.

Until the transfer of the permit has been approved by the CDPHE the Contractor shall continue to adhere to all permit requirements. Requirements shall include erosion control inspections, BMP installation, BMP maintenance, BMP repair, including seeded areas, and temporary BMP removal. All documentation shall be submitted to the Engineer and placed in the SWMP notebook.

All costs associated with the Contractor applying for, holding, and transferring the CDPS-SCP permit between parties will not be measured and paid for separately, but shall be included in the work in accordance with subsection 107.02.

2. *CDOT Obtained Stormwater Construction Permit.* CDOT will obtain the Colorado Discharge Permit System Stormwater Construction Permit (CDPS-SCP) from the Colorado Department of Public Health and Environment (CDPHE) prior to the award of contract. The Contractor may be legally required to obtain all other permits associated with specific activities within, or off the Right of Way, such as borrow pits, concrete or asphalt plant sites, waste disposal sites, or other facilities. These permits may include local agency or federal grading or stormwater permits. It is the Contractor's responsibility to obtain these permits. The Contractor shall consult with the Engineer, and contact the Colorado Department of Public Health and Environment (CDPHE) or other appropriate federal, state, or local agency to determine the need for any permit.

The Contractor shall coordinate with CDOT on transferring the respective Permit to the Contractor upon award of the Contract. The Contractor shall submit the "Application For Transfer of Ownership For All Permits, Certifications and Authorizations" for the CDPHE Permit, prior to commencement of construction. Work shall not begin until the CDPS-SCP permit transfer has been approved by CDPHE, unless otherwise directed.

If a Utility Company has obtained a permit for the area prior to the Contractor being on site, then the Contractor shall coordinate with the Utility Company to transfer those areas over to the Contractor prior to work commencing. The Contractor shall not commence construction until Application for Transfer of Ownership for All Permits,

Certifications and Authorizations has been approved by CDPHE and submitted to the Engineer.

To initiate partial acceptance of the stormwater construction work (including seeding and planting required for erosion control), the Contractor shall request in writing a Stormwater Completion Walkthrough. The Engineer will set up the walkthrough and will include: the Engineer or designated representative, Superintendent or designated representative, Stormwater Management Plan (SWMP) Administrator, Region Water Pollution Control Manager (RWPCM) and Landscape Architect representing the region. Unsatisfactory and incomplete erosion control work will be identified in this walkthrough, and will be summarized by the Engineer in a punch list. The Water Quality Permit Transfer to Maintenance Punch List may be used as a template in creating the Engineer's punch list.

The Engineer will coordinate with CDOT Maintenance on regular inspections of the corrective work. The completed action items associated with the corrective work shall be shown as completed on the Punch List. Upon completion of all items shown, the Contractor shall submit the completed Punch List to the Engineer for review. Upon written approval of the Punch List, the Contractor shall submit the "Application for Transfer of Ownership for All Permits, Certifications and Authorizations"

to the CDPHE requesting transfer of ownership of the CDPS-SCP to CDOT Maintenance. When requested by CDOT Maintenance and

approved by the Engineer, the Permit may be transferred by the Contractor to the Resident Engineer instead of CDOT Maintenance.

Until the transfer of the permit has been approved by the CDPHE the Contractor shall continue to adhere to all permit requirements. Requirements shall include erosion control inspections, BMP installation, BMP maintenance, BMP repair, including seeded areas, and temporary BMP removal. All documentation shall be submitted to the Engineer and placed in the SWMP notebook.

All costs associated with the Contractor applying for, holding, and transferring the CDPS-SCP permit between parties will not be measured and paid for separately, but shall be included in the work in accordance with subsection 107.02.

(d) *Measurement and Payment.*

1. All the work listed in (b) above, including but not limited to dewatering, erosion control for dewatering, and disposal of water resulting from dewatering operations, including all costs for CDPHE concurrences and permits, will not be measured and paid for separately, but shall be included in the work.
2. The Contractor shall be liable for any penalty (including monetary fines) applied to the Department caused by the Contractor's noncompliance with any water quality permit or certification. Monetary fines shall be deducted from any money due to the Contractor. If the monetary fine is in excess of all the money due to the Contractor, then the Contractor shall pay to the Department the amount of such excess.
3. The Contractor will not receive additional compensation, or time extensions, for any disruption of work or loss of time caused by any actions brought against the Contractor for failure to comply with good Engineering, hydrologic and pollution control practices.
4. If a spill occurs as a direct result of the Contractor's actions or negligence, the cleanup of such spill shall be performed by the Contractor at the Contractor's expense.
5. Areas exposed to erosion by fire resulting from the Contractor's operations shall be stabilized in accordance with Section 208 by the Contractor and at the Contractor's expense.

CONSTRUCTION DETAILS

DIVISION 200 EARTHWORK

SECTION 201 CLEARING AND GRUBBING

DESCRIPTION

201.01 This work consists of clearing, grubbing, removing, and disposing of vegetation and debris within the limits of the right of way, easement areas, borrow pits, and other areas shown in the Contract or required by the work. Vegetation and objects designated to remain shall be preserved free from injury or defacement.

CONSTRUCTION REQUIREMENTS

201.02 The Engineer will designate all trees, shrubs, plants, and other objects to remain. Every object that is designated to remain and is damaged shall be repaired or replaced as directed, at the Contractor's expense.

Clearing and grubbing shall extend to the toe of fill or the top of cut slopes, unless otherwise designated.

All surface objects, trees, stumps, roots, and other protruding obstructions not designated to remain shall be cleared and grubbed. In areas to be rounded at the tops of backslopes, stumps shall be removed to at least 2 feet below the surface of the final slope line.

Except in areas to be excavated, all holes resulting from the removal of obstructions shall be backfilled with suitable material and compacted in accordance with subsection 203.06.

Burning of perishable material will not be permitted without the written approval of the Engineer. If permitted, perishable material shall be burned under the constant care of the Contractor, at times and in a manner that will not endanger the surrounding vegetation, adjacent property, or objects designated to remain. Burning shall be done in accordance with applicable laws and ordinances.

No material or debris shall be disposed of within the project limits without the written permission of the Engineer. Material or debris that is disposed of within the project limits shall be buried to a depth of at least 2 feet and the surface shall be reshaped to match the adjacent ground line. The Contractor shall make all arrangements to obtain written permission from property owners for disposal locations outside the limits and view of the project. Copies of this written agreement shall be furnished to the Engineer before the disposal area is used.

All cleared merchantable timber shall be removed from the project and shall become the property of the Contractor.

Branches on trees or shrubs shall be removed as directed. Branches of trees extending over the roadbed shall be trimmed to give a clear height of 20 feet above the roadbed surface. All trimming shall be done in accordance with good tree surgery practices.

The Contractor shall clear and grub the areas within the excavation or embankment grading limits and shall include the removal from the ground of brush, roots, sod, grass, residue of agricultural crops, sawdust, and other vegetable matter. See subsection 208.04(e) for disturbed area limits.

METHOD OF MEASUREMENT

201.03 Measurement will be by one of the following methods:

- (a) Area Basis. The work to be paid for will be the number of acres acceptably cleared and grubbed, including scalping, within the limits shown on the plans or staked by the Engineer.
- (b) Lump Sum Basis. When the Contract contains a clearing and grubbing lump sum item, no measurement will be made.

BASIS OF PAYMENT

201.04 The accepted quantities of clearing and grubbing will be paid for at the contract unit prices as follows:

- (a) Area Basis. The quantities will be paid for at the contract unit price bid per acre for each pay item that appears in the bid schedule.
- (b) Lump Sum Basis. When the bid schedule contains a lump sum item, the lump sum price so bid will be paid and shall be full compensation for clearing and grubbing the entire project.

Clearing and grubbing beyond the limits designated under this item will be paid for as Extra Work in accordance with subsection 104.03.

Payment will be made under:

Pay Item	Pay Unit
Clearing	Acre, Lump Sum
Grubbing	Acre, Lump Sum
Clearing and Grubbing	Acre, Lump Sum

- (c) Exclusions. When the bid schedule does not contain an estimated quantity or a lump sum item for clearing and grubbing, the work will not be paid for separately, but shall be included in the work.

SECTION 202 REMOVAL OF STRUCTURES AND OBSTRUCTIONS

DESCRIPTION

202.01 This work consists of the removal and disposal of trees, slope and ditch protection, abandoned utility services, curb, gutter, pipes, sidewalk, structures, bridges or parts of bridges, railroad appurtenances, traffic control devices, impact attenuators, guardrail, fences, foundations, detours, pavements, pavement markings, and all other obstructions that are not designated or permitted to remain. It shall also include salvaging, stockpiling and loading salvable materials, sandblasting, plugging structures, cleaning culverts, and sawing and cutting to facilitate controlled breaking and removal of concrete and asphalt to a neat line. Except in areas to be excavated, the resulting trenches, holes, and pits shall be backfilled. This work also consists of plugging and abandoning water wells as designated in the Contract.

Materials removed and not designated in the Contract to be salvaged or incorporated into the work shall become the property of the Contractor.

CONSTRUCTION REQUIREMENTS

202.02 General. The Contractor shall raze, remove, and dispose of all structures and obstructions which are identified on the project, except utilities, structures and obstructions removed under other contractual agreements, and salvable material designated to remain the property of the Department.

Basements and other cavities left by structure removal shall be filled to the level of the surrounding ground with suitable material and, if within the construction limits, shall be compacted in accordance with subsection 203.06.

Bridges, culverts, and other drainage structures shall not be removed until satisfactory arrangements have been made to accommodate traffic and drainage.

Blasting or other operations used to remove existing structures or obstructions, which may damage new construction, shall be completed prior to placing the new work.

Where portions of structures are to be removed, the portions designated to remain shall be prepared to fit the new construction, and shall be protected from damage. All damage to structures designated to remain in place shall be repaired at the Contractor's expense. Method of repair shall be approved by the Engineer.

Sawing of concrete shall be done to a true line, with a vertical face, unless otherwise specified. The minimum depth of a saw cut in concrete shall be 2 inches or to the depth of the reinforcing steel, whichever occurs first.

Removed concrete and asphalt material may be used to construct embankments in

accordance with subsection 203.07.

Where culverts or sewers are to be left in place and plugged, the ends of concrete or masonry culverts shall be filled with suitable material. The ends of corrugated metal pipe culverts shall be crushed. Culvert and sewer ends are to be sufficiently filled or crushed to prevent future settlement of embankments. Plugging of culverts shall include removal of headwalls and other appurtenances where necessary to accommodate the work.

Procedures for abandoning water wells shall conform to the Revised and Amended Rules and Regulations of the State of Colorado, Division of Water Resources, Board of Examiners of Water Well Construction and Pump Installation Contractors, (Board). The State Engineer who acts for the Board is located at 818 Centennial Bldg., 1313 Sherman St., Denver, CO 80203 (Phone 303-866-3587).

The Contractor shall properly plug and abandon the designated wells and file an abandonment report for each. An abandonment report shall be prepared using Form GWS-9 obtained from the Board at the above address. The report shall describe the well location and how it was plugged. This report shall be submitted to the Board, with a copy given to the Project Engineer, within 60 days after performing the work.

Existing guardrail shall not be removed unless the need for the guardrail has been eliminated or the hazard has been protected or delineated. The duration and manner of protection or delineation shall be submitted in writing for approval by the Engineer.

202.03 Salvable Material. All salvable material designated in the Contract to remain the property of the Department shall be removed without damage, in sections or pieces which may be readily transported, and shall be stockpiled by the Contractor at specified locations within the project limits. The Contractor shall safeguard salvable materials and shall be responsible for the expense of repairing or replacing damaged or missing material until it is incorporated into the work, or is loaded onto Department equipment by the Contractor. **Signs and Traffic Signals.** Removal of signs shall include removal of posts, footings, pedestals, sign panels, and brackets. Concrete adhering to salvable sign posts shall be removed. Removal of sign panel shall include removal of the panel and its attachment hardware from the existing installation and adjusting the spacing of the remaining panels.

The removal of traffic signal items shall include poles, mast arms, signal heads, span wires, footings, all attachment hardware, and other incidental materials. Removal of signal pole or pedestal pole shall include pole, span wire, cable, signal heads, overhead sign support wire, footings, and pedestrian push buttons. Removal of traffic signal controller and cabinet shall include removal of the footing and all auxiliary equipment contained within the cabinet.

202.05 Pavement Markings. Pavement markings shall be removed from the pavement to the maximum extent possible, by methods that do not materially alter or damage the surface or texture of the pavement, to the satisfaction of the Engineer. The proposed method of pavement marking removal shall be designated by the Contractor at the Pre-construction Conference, and approved by the Engineer. Operations that do not produce the desired result, damage the pavement, or may constitute a hazard to the traveling public will not be permitted. Materials deposited on the pavement as a result of removal of pavement markings shall be promptly removed so as not to interfere with traffic or roadway drainage.

Pavement markings, designated to be removed, shall be removed before any change is made in traffic patterns. Temporary marking tape sections longer than one foot shall be removed before placement of the final pavement course. All tape shall be removed on sections where tape conflicts with revised traffic lanes prior to opening of new lanes to traffic.

- (a) **Removal of Temporary Pavement Marking on Final Alignment.** Temporary pavement marking paint on the approved final alignment shall be removed completely from the roadway surface at locations of permanent pavement markings as shown on the plans. The removal location shall be clean, dry and free of laitance, oil, dirt, grease, paint, and other foreign contaminants prior to application of final pavement marking.

The Contractor shall not remove more pavement marking paint than what can be replaced with permanent pavement marking during the same working day or working period. If a storm or other event prevents the Contractor from completing the placement of permanent marking, the Contractor shall halt the removal operation and place raised flexible pavement markers where temporary pavement markings have been removed but the permanent markings have not been placed. Raised flexible pavement markers shall be installed with one marker at 40-foot centers. Raised flexible pavement markers shall remain in place while the pavement is drying prior to the permanent marking application. Permanent marking application shall resume when the pavement is dry and has had no moisture for a minimum of 24 hours.

- (b) **Removal of Temporary Pavement Marking on Transitions.** Removal of pavement marking paint on temporary transitional alignments shall be performed by grinding or water-blasting. The removal shall result in 100 percent removal of the paint and a wide swath of ground pavement surrounding the former location of the temporary paint. The width of the swath shall be as follows; the center of the swath shall be the location of the paint line:

Width of Pavement Marking to be removed	Width of Swath
≤ 8 inches	12 inches
> 8 inches	15 inches

202.06 Detours. The Contractor shall completely remove the detour and dispose of the materials in accordance with the Contract. **Pavements, Sidewalks, Curbs.** All concrete pavement, sidewalks, structures, curbs, gutters, etc., designated for removal, shall be disposed of in accordance with subsection 201.02. Concrete pavement to be broken and left in place shall be broken so the largest fragment does not exceed 1 square yard in surface.

202.08 Portions of Structures. Unless otherwise directed, the substructures of existing structures shall be removed down to the natural stream bottom and those parts outside of the stream shall be removed down 1 foot below natural ground surface. Where such portions of existing structures lie wholly or in part within the limits of a new structure, they shall be removed as necessary to accommodate the construction of the proposed structure.

Reinforcing steel projecting from the structure, designated to remain, shall be cleaned and aligned to the new construction. Required dowels shall be securely grouted with approved grout. When concrete is removed, all exposed reinforcing steel designated to remain in place shall be cleaned by sandblasting to sound steel free of oil, dirt, concrete fragments or laitance, loose rust scale, and other coatings that would destroy or inhibit the bond with the new concrete.

Adequate measures shall be taken by the Contractor to protect the steel from contamination or corrosion. Reinforcing steel, contaminated as a result of the Contractor's failure to provide adequate protection, shall be re-sandblasted at the Contractor's expense with no allowance for contract time extension.

A protective device shall be placed between the sandblasting operations and the traveling public.

202.09 Removal of Asphalt Mat (Planing). The Contractor shall not commence planing operations until the hot mix asphalt (HMA) Mix Design (CDOT Form 43) has been approved and signed.

Prior to beginning planing operations, the Contractor shall submit a planing plan for approval by the Engineer. This plan shall include as a minimum:

- (1) The number and types of planers to be used.
- (2) The width and location of each planing pass.
- (3) The number and types of brooms to be used, and their locations with respect to the planers. The Contractor shall have at least one back up broom on the project at all times in case one of the operating brooms breaks down.

Each planer shall conform to the following:

The planer shall have sufficient power, traction, and stability to maintain an accurate depth of cut. The propulsion and guidance system of the planer shall be maintained in such condition that the planer may be operated to straight and true lines.

Operation with broken or missing teeth will not be allowed. Worn teeth shall be replaced if the planer does not produce a uniform surface.

The planer shall be capable of picking up the removed asphalt in a single operation. A self-loading conveyer shall be an integral part of the planer. Windrows will not be allowed.

All planed areas shall be broomed with a pick up broom, unless otherwise specified, before being opened to traffic. A sufficient number of brooms shall be used immediately after planing to remove all planed material remaining on the roadway.

If the Contractor fails to adequately clean the roadway, work shall cease until the Engineer has approved the Contractor's revised written proposal to adequately clean the roadway.

At the completion of each day's work, vertical edges caused by planing that are greater than 1 inch in height shall be: Longitudinal - tapered to not less than a 3:1 slope, Transverse - tapered to not less than a 50:1 slope.

The roadway shall be left in a safe and usable condition at the end of each work day. All required pavement markings, removed by the planing, shall be restored before the roadway is opened to traffic.

All planing shall be completed parallel to the travel lanes unless otherwise directed by the Engineer.

All planing shall be completed full width before resurfacing commences.

202.10 Clean Culvert.. Culverts designated in the Contract to be cleaned shall be cleaned by removing all sedimentation and debris from within the culvert and all appurtenant structures.

METHOD OF MEASUREMENT

202.11 When the Contract provides payment for removal of obstructions on a lump sum basis, this payment will include all stipulated structures and obstructions encountered within the right of way in accordance with this section. When the Contract provides payment for the removal of specific items on a unit basis, measurement will be by the unit.

Removal of pavement marking will be measured in square feet, completed and accepted. Sandblasting of pavement that is to be covered with pavement marking material will be measured as the same area as measured for the pavement marking for which the sandblasting is required.

Removal of asphalt mat (planing) will be measured by the area in square yards, completed to the required depth, and accepted.

Sandblasting reinforcing steel will be measured by the square yard of deck surface. Multiple layers of reinforcing steel within a common area of the deck exposed and

requiring sandblasting will not be measured separately.

Clean culvert will be measured by the number of culverts acceptably cleaned as designated on the plans, irrespective of the kind or size involved.

Abandon well will be measured by the actual number plugged, abandoned, and the abandonment report submitted.

Removal of temporary pavement marking on transitions will be measured by the actual square feet of the swath that is removed for the required width. Removal of pavement marking for the permanent alignment will be measured as the actual in square feet of pavement marking that is removed.

BASIS OF PAYMENT

202.12 The accepted quantities will be paid for at the contract unit price for each of the pay items listed below that appear in the bid schedule. Payment shall be full compensation for sawing, removing, disposal, excavation and subsequent backfill, and salvage of materials removed, their custody, preservation, storage, and disposal as provided herein.

Payment will be made under:

Pay Item	Pay Unit
Removal of Structures and Obstructions	Lump Sum
Removal of	Each, Linear Foot, Square Yard Cubic Yard
Removal of Asphalt Mat (Planing)	Square Yard
Removal of Pavement Marking	Square Foot
Removal of Pavement Marking (12 Inch)	Square Foot
Removal of Pavement Marking (15 Inch)	Square Foot
Plug	Each
Clean Culvert	Each
Abandon Well	Each
Sandblasting	Square Foot
Sandblasting Reinforcing Steel	Square Yard

When the Contract does not include pay items for removal of structures and obstructions, the removal will not be paid for separately but shall be included in the work.

Payment for abandon well will be full compensation for all labor and materials

required to complete the work, including preparing and submitting the abandonment report.

Temporary raised flexible pavement markers used in accordance with subsection 202.05(a) will not be measured and paid for separately, but shall be included in the work.

SECTION 207 TOPSOIL

DESCRIPTION

207.01 This work consists of salvaging and stockpiling topsoil, and excavating suitable topsoil from stockpiles, contractor sources, available sources, or from the approved natural ground cover to place on designated areas. It shall include the placing of topsoil upon constructed cut and fill slopes after grading operations are completed.

MATERIALS

207.02 Topsoil shall consist of loose friable soil from the zone of major root development free of subsoil, refuse, stumps, woody roots, rocks, brush, noxious weed seed and reproductive plant parts from current state and county weed lists, heavy clay, hard clods, toxic substances, or other material which would be detrimental to its use on the project.

Wetland topsoil material shall consist of the moist, organic soil, including any existing wetland vegetation and seeds, to be excavated from areas as shown on the plans or as directed.

CONSTRUCTION REQUIREMENTS

207.03 Wetland topsoil material shall be excavated from the designated area to a maximum depth of 12 inches, or as otherwise designated, and placed within 24 hours in the specified area. The Contractor shall prepare the relocation site to elevations specified and approved by the Engineer prior to excavating the wetlands. If the Engineer determines that this is not possible, then the Contractor shall stockpile the material in an approved area, to remain undisturbed until the relocation site has been prepared. Storage time within the stockpile shall be as short as possible. Wetland topsoil material shall be placed over the prepared relocation areas to a depth of 12 inches, or as otherwise designated.

Topsoil within the limits of the roadway shall be salvaged prior to beginning hauling, excavating, or fill operations by excavating and stockpiling the material at designated locations in a manner that will facilitate measurement, minimize sediment damage, and not obstruct natural drainage. Topsoil shall be placed directly upon completed cut and fill slopes whenever conditions and the progress of construction will permit.

Topsoil shall be placed at locations and to the thickness provided in the Contract and shall be keyed and tracked to the underlying material without creating a compacted surface by the use of harrows, bulldozers, rollers, or other equipment suitable for the purpose.

Salvaged topsoil exceeding the quantity required under the Contract shall be disposed of at locations acceptable to the Engineer.

METHOD OF MEASUREMENT

207.04 Topsoil salvaged from the roadway and placed in stockpiles shall be measured in the stockpile in cubic yards by the method of average end areas and paid for as Stockpile Topsoil.

Topsoil salvaged from the roadway, taken from stockpiles or from approved pits, hauled and placed directly upon completed cut and fill slopes shall be measured at its source in cubic yards, as described in subsection 203.11, and paid for as Topsoil.

Topsoil generated from the roadway and placed in windrows will be measured at its source in cubic yards, as described in subsection 203.11, and paid for as Stockpile Topsoil. When it is subsequently placed upon the completed cut and fill slopes, the same quantity will be paid for as Topsoil, except that adjustment in quantity shall be made if the total windrowed quantity is not utilized.

Wetland topsoil material excavated from areas within the right-of-way and placed in stockpiles will be measured in the stockpile by the method of average end areas and paid for as Stockpile Wetland Topsoil.

Wetland topsoil material excavated from areas within the right-of-way or from stockpiles, hauled and placed directly on a relocated site will be measured at its source in cubic yards, as described in subsection 203.11, and paid for as Wetland Topsoil.

Topsoil secured from the Contractor's source will be measured in place by measuring random depths of topsoil, and computing the volume by multiplying the area times the average depth

BASIS OF PAYMENT

207.05 The accepted quantities measured as provided above will be paid for at the contract unit price per cubic yard for each of the pay items listed below that appear in the bid schedule.

Payment will be made under:

Pay Item	Pay Unit
Stockpile Topsoil	Cubic Yard
Topsoil	Cubic Yard
Stockpile Wetland Topsoil	Cubic Yard
Wetland Topsoil	Cubic Yard

SECTION 208 EROSION CONTROL

DESCRIPTION

208.01 This work consists of constructing, installing, maintaining, and removing when required, Best Management Practices (BMPs) during the life of the Contract to prevent or minimize erosion, sedimentation, and pollution of any State waters as defined in subsection 107.25, including wetlands.

The Contractor shall coordinate the construction of temporary BMPs with the construction of permanent BMPs to assure economical, effective, and continuous erosion and sediment control throughout the construction period.

When a provision of Section 208 or an order by the Engineer requires that an action be immediate or taken immediately, it shall be understood that the Contractor shall at once begin effecting completion of the action and pursue it to completion in a manner acceptable to the Engineer, and in accordance with the Colorado Discharge Permit System Stormwater Construction Permit (CDPS-SCP) requirements.

MATERIALS

208.02 Erosion control materials are subject to acceptance in accordance with subsection 106.01. Erosion control materials shall be subject to the following approval process:

Material	Approval Process	Notes:
Erosion Bales (Weed Free)	COC	The Contractor shall provide a transit certificate number or a copy of the transit certificate as supplied from the producer.
Silt Fence	COC	
Silt Berm	APL	
Erosion Log (Type 1 and 2)	COC	
Silt Dikes	COC	
Pre-fabricated Concrete Washout Structures (above ground)	APL	
Pre-fabricated Vehicle Tracking Pad	APL	
Aggregate Bag	COC	
Storm Drain Inlet Protection (Type I, II, and III)	APL	
COC = Certificate of Compliance; APL= Approved Product List		

The material for BMPs shall conform to the following:

- (a) *Erosion Bales*: Material for erosion bales shall consist of Certified Weed Free hay or straw. The hay or straw shall be certified under the Colorado Department of Agriculture Weed Free Forage Certification Program and inspected as regulated by the Weed Free Forage Act, Title 35, Article 27.5, CRS. Each certified weed free erosion bale shall be identified by blue and orange twine binding the bales.

The Contractor shall not place certified weed free erosion bales or remove their identifying twine until the Engineer has inspected them.

The Contractor may obtain a current list of Colorado Weed Free Forage Crop Producers who have completed certification by contacting the Colorado Department of Agriculture, Weed Free Forage Program, 305 Interlocken Pkwy, Broomfield, CO 80021, Contact: Weed Free Forage Coordinator at (303) 869-9038. Also available at www.colorado.gov/ag/csd.

Bales shall be approximately 5 cubic feet of material and weigh at least 35 pounds. Stakes shall be wood and shall be 2 inch by 2 inch nominal.

- (b) *Silt Fence*. Silt fence posts shall be wood with a minimum length of 42 inches. Wood posts shall be 1.5 inch by 1.5 inch nominal. Geotextile shall be attached to wood posts with three or more staples per post.

Silt fence geotextile shall conform to the following requirements:

Physical Requirements for Silt Fence Geotextiles

Property	Wire Fence Supported Requirements	Self-Supported Requirements Geotextile Elongation <50%	Test Method
Grab Strength, lbs	90 minimum	124 minimum	ASTM D4632
Permittivity sec-1	0.05	0.05	ASTM D4491
Ultraviolet Stability	Minimum 70% Strength Retained	Minimum 70% Strength Retained	ASTM D4355

Silt Fence (Reinforced). Silt fence posts shall be metal "studded tee" T-post with a minimum length of 66 inches. Metal posts shall be "studded tee" with .095 inch minimum wall thickness. Wire fabric reinforcement for the silt fence geotextile shall be a minimum of 14 gauge with a maximum mesh spacing of 6 inches. Geotextile shall be attached to welded wire fabric with ties or nylon cable ties at 12 inches on center at top, middle and bottom wire. Welded wire fabric shall be attached to the post with a minimum three 12 gauge wire ties per post. Vinyl or rubber safety caps shall be installed on all T-post.

- (c) *Temporary Berms.* Temporary berms shall be constructed of compacted soil.
- (d) *Temporary Slope Drains.* Temporary slope drains shall consist of fiber mats, plastic sheets, stone, concrete or asphalt gutters, half round pipe, metal or plastic pipe, wood flume, flexible rubber, or other materials suitable to carry accumulated water down the slopes. Outlet protection riprap shall conform to section 506. Erosion control geotextile shall be a minimum Class 2, conforming to subsection 712.08.
- (e) *Silt Berm.* Silt berm shall consist of an ultraviolet (UV) stabilized high-density polyethylene, shall be triangular in shape, and shall have the following dimensions :

Width	6 - 11 inches
Height	6 - 10 inches
Weight	0.3 - 1.4 lbs./sq. ft.
Percent Open Area	30 – 50%

Securing spikes shall be 10 to 12 inch x 0.375 inch diameter (minimum).

- (f) *Rock Check Dam.* Rock Check dams shall be constructed of stone. Stone shall meet the requirements of Section 506.
- (g) *Sediment Trap.* In constructing an excavated sediment trap, excavated soil may be used to construct the dam embankment, provided the soil meets the requirements of subsection 203.03. Outlet protection riprap shall be the size specified in the Contract and shall conform to Section 506. Erosion control geotextile shall be a minimum Class 1, conforming to subsection 712.08.
- (h) *Erosion Logs.* Erosion logs shall be one of the following types unless otherwise shown on the plans:
- (1) Erosion Log (Type 1) shall be curled aspen wood excelsior with a consistent width of fibers evenly distributed throughout the log. The casing shall be seamless, photo-degradable tube netting. The curled aspen wood excelsior shall be fungus free, resin free, and free of growth or germination inhibiting substances.
 - (2) Erosion Log (Type 2) shall consist of a blend of 30-40 percent weed free compost and 60-70 percent wood chips. The compost-wood blend material shall pass a 50 mm (2 inch) sieve with a minimum of 70 percent retained on the 9.5 mm (3/8 inch) sieve and comply with subsection 212.02 for the remaining compost physical properties. The compost-wood chip blend may be pneumatically shot into a geotextile cylindrical bag or be pre-manufactured. The geotextile bag shall consist of HDPE or polypropylene mesh (knitted, not extruded) with openings of 1/8 to 3/8 inch

and contain the compost-wood chip material while not limiting water infiltration.

Erosion log (Type 1 and Type 2) shall have minimum dimensions as shown in Table 208-1, based on the specified diameter of the log.

**Table 208-1
Nominal Dimensions of Erosion Logs**

Diameter Type 1 (Inches)	Diameter Type 2 (Inches)	Length (feet)		Weight (minimum) (pounds/foot)	Stake Dimensions (Inches)
		Min.	Max.		
9	8	10	180	1.6	1.5 by 1.5 (nominal) by 18
12	12	10	180	2.5	1.5 by 1.5 (nominal) by 24
20	18	10	100	4.0	2 by 2 (nominal) by 30

Stakes to secure erosion logs shall consist of pinewood or hardwood.

- (i) *Silt Dikes*. Silt dikes shall be pre-manufactured triangular shaped urethane foam covered with a woven geotextile fabric. The fabric aprons shall extend a minimum of two feet beyond each side of the triangle.

Each silt dike shall have the following dimensions:

Dimension	Length
Center height	8 to 10 inches
Base	16 to 21 inches
Section length	3 to 7 feet
Section width including fabric extensions	5.6 feet

Staples shall be 6 gauge and at least 8 inches long.

- (j) *Concrete Washout Structure*. The Contractor shall construct a washout structure that will contain washout from concrete placement and construction equipment cleaning operations. Embankment required for the concrete washout structure may be excavated material, provided that this material meets the requirements of Section 203 for embankment.

A pre-fabricated concrete washout structure shall be used only when specified in the Contract. It shall consist of a watertight container designed to contain liquid and solid waste from concrete washout.

- (k) *Vehicle Tracking Pad*. Aggregate for the vehicle tracking pad shall be crushed natural aggregate with at least two fractured faces that meets the following gradation requirements:

Sieve size	Percent by weight Passing Square Mesh Sieves
75 mm (3 inch)	100
50 mm (2 inch)	0-25
19.0 mm (¾ inch)	0-15

Recycled crushed concrete or asphalt shall not be used for vehicle tracking pads.

Erosion control geotextile shall be Class 2 and conform to the requirements of

Pre-fabricated vehicle tracking pads if specified in the Contract shall have the subsection 712.08. following properties.

Minimum overall dimensions of the modular systems shall be:

Width of pad along edge of roadway	14 feet
Length of pad	30 feet

Weight (min.) (lbs./sq. ft.)	8
Crush strength (min.) (psi)	400

- (l) *Aggregate Bag.* Aggregate bags shall consist of crushed stone or recycled rubber filled fabric with the following properties :

Diameter (inches)	Weight (minimum) (pounds per foot)
6-8	6
10	10
12	15

Rubber used in bags shall be clean, 95 percent free of metal and particulates.

Crushed stone contained in the aggregate bags shall conform to subsection 703.09, Table 703-7 for Class C.

The aggregate bag shall consist of a woven geotextile fabric with the following properties:

Property	Requirement	Test Method
Grab Tensile Strength	90 lbs. min.	ASTM D4632
Trapezoid Tear Strength	25 lbs. min.	ASTM D4533
Mullen Burst	300 psi	ASTM D3786
Ultraviolet Resistance	70%	ASTM D4355

- (m) *Storm Drain Inlet Protection.* Storm drain inlet protection shall consist of aggregate filled fabric with the following dimensions:

Storm Drain Inlet Protection Properties	Protection Types		
	1Type I	Type II	3Type III
Diameter	4 in.	4 in.	N/A
Minimum Section Length	7 ft.	5 ft.	5 ft.
Apron Insert	---	30 in. or sized to grate	30 in or sized to grate
¹ Type I protection shall be used with Inlet Type R. ² Type II protection shall be used with Combination Inlet. Option A or B ³ Type III protection shall be used with Vane Grate Inlet only. Option A or B Note: Options A and B are shown on Standard Plan M-208-1.			

The Storm Drain Inlet Protection (Type I, II and III) shall consist of a woven geotextile fabric with the following properties:

Property	Test Method	Unit	Requirement
Grab tensile strength	ASTM D4632	lbs.	minimum 350X280
Mullen Burst Strength	ASTM D3786	lbs.	600
Trapezoid Tear Strength	ASTM D4533	lbs.	minimum 110X95
Percent Open Area	COE-22125-86	%	28
Water Flow Rate	ASTM D4491	gal./min./sq. ft.	250
Ultraviolet Resistance	ASTM D4355	%	70

Curb roll for Storm Drain Inlet Protection (Type I and II) shall have an approximate weight of 7 to 10 pounds per linear foot of device. The device shall be capable of conforming to the shape of the curb. Aggregate contained in the storm drain inlet device shall consist of gravel or crushed stone conforming to subsection 703.09, Table 703-7 for Class C.

Storm Drain Inlet Protection (Type III) shall have insert containment (option A) or insert without storage capacity (option B).

CONSTRUCTION REQUIREMENTS

208.03 Project Review, Schedule, and Erosion Control Management. Prior to construction, an on-site Environmental Pre-construction Conference shall be held. The conference shall be attended by:

- (1) The Engineer.
- (2) The Superintendent.
- (3) The Contractor's SWMP Administrator.
- (4) Supervisors or Foremen of subcontractors working on the project.
- (5) The Region Water Pollution Control Manager (RWPCM).
- (6) CDOT personnel (e.g., CDOT Landscape Architect) who prepared or reviewed the Stormwater Management Plan (SWMP).

At this conference, the attendees shall discuss the SWMP, CDPS-SCP, sensitive habitats on site, wetlands, other vegetation to be protected, and the enforcement mechanisms for not meeting the requirements of this specification.

Prior to beginning construction the Contractor shall evaluate the project site for storm water draining into or through the site. When such drainage is identified, BMPs (i.e., Control Measures) shall be used if possible to divert stormwater from running on-site and becoming contaminated with sediment or other pollutants. The diversion may be accomplished with a temporary pipe or other conveyance to prevent water contamination or contact with pollutants. Run-on water that cannot be diverted shall be treated as construction runoff and adequate BMPs shall be employed.

The SWMP Administrator shall evaluate all non-stormwater coming onto the site, such as springs, seeps, and landscape irrigation return flow. If such flow is identified, BMPs shall be used to protect off-site water from becoming contaminated with sediment or other pollutants.

The SWMP Administrator shall review existing inlets and culverts to determine if inlet protection is needed due to water flow patterns. Prior to beginning construction, inlets and culverts needing protection shall be protected and the location of the implemented BMP added to the SWMP site map.

Prior to construction, the Contractor shall implement appropriate BMPs for protection of wetlands, sensitive habitat, and existing vegetation from ground disturbance and other pollutant sources, in accordance with the approved project schedule as described in subsection 208.03(b).

When additional BMPs are required and approved by the Engineer, the Contractor shall implement the additional BMPs and the SWMP Administrator shall record and describe them on the SWMP site map. The approved BMPs will be measured and paid for in accordance with subsections 208.11 and 208.12.

(a) *Project Review.* The Contractor may submit modifications to the Contract's BMPs in a written proposal to the Engineer. The written proposal shall include the following information :

- (1) Reasons for changing the BMPs.
- (2) Diagrams showing details and locations of all proposed changes.
- (3) List of appropriate pay items indicating new and revised quantities.
- (4) Schedules for accomplishing all erosion and sediment control work.
- (5) Effects on permits or certifications caused by the proposed changes.

The Engineer will approve or reject the written proposal in writing within 5 working days after the submittal. The Engineer may require additional control measures prior to approving the proposed modifications. Additional modifications and additional BMPs will be paid for at the Contract Unit Price for the specific items involved. If no items exist, they will be paid for as extra work in accordance with subsection 109.04.

(b) *Erosion and Sediment Control Activities.* The erosion and sediment control activities shall be included in the weekly meeting update. The project schedule shall specifically indicate the sequence of clearing and grubbing, earthwork operations, and construction of temporary and permanent erosion control features and stabilization. The project schedule shall include erosion and sediment control work for haul roads, borrow pits, storage and asphalt or concrete batch sites, and all areas within the project limits. If during construction the Contractor proposes changes which would affect the Contract's BMPs, the Contractor shall propose revised BMPs to the Engineer for approval in writing. If necessary, the SWMP Administrator shall update proposed sequencing of major activities in the SWMP. Revisions shall not be implemented until the proposed measures have been approved in writing by the Engineer.

(c) *Erosion Control Management (ECM).* Erosion Control Management for this project shall consist of Erosion Control Inspection and the Administration of the Stormwater Management Plan (SWMP). All ECM staff shall have working knowledge and experience in construction, and shall have successfully completed the Transportation Erosion Control Supervisory Certificate Training (TECS) as provided by the Department. The Superintendent will not be permitted to serve in an ECM role. The Erosion Control Inspector and the Stormwater Administrator may be the same person in projects involving less than 40 acres of disturbed area.

1. Stormwater Management Plan (SWMP) Administration. The SWMP Plan shall be maintained by a SWMP Administrator. The SWMP Administrator shall have completed the TECS certification training provided by the

Department. In the case of a project requiring only one TECS, the SWMP Administrator may also be the Erosion Control Inspector for the project. The name of the SWMP Administrator shall be recorded on SWMP Plan Section 3. B. The SWMP Administrator shall have full responsibility to maintain and update the SWMP Plan and identify to the Superintendent critical action items needed to conform to the CDPS-SCP as follows:

- (1) Complete the SWMP Notebook as described in subsection 208.03 (d).
- (2) Participate in the Environmental Pre-construction Conference.
- (3) Attend weekly meetings.
- (4) Attend all Headquarter and Region water quality control inspections. The Contractor and the Contractor's SWMP Administrator will be notified a minimum of five days in advance of each inspection by the region or headquarter water quality staff.
- (5) Coordinate with the Superintendent to implement necessary actions to reduce anticipated or presently existing water quality or erosion problems resulting from construction activities.
- (6) Coordinate with the Superintendent to ensure that all labor, material, and equipment needed to install, maintain, and remove BMPs are available as needed.
- (7) During construction, update and record the following items on the SWMP site map as changes occur:
 - (i) Limits of Construction (LOC).
 - (ii) Areas of disturbance (AD).
 - (iii) Limits of Disturbance (LDA).
 - (iv) Limits of cut and fill.
 - (v) Areas used for storage of construction materials, equipment, soils, or wastes.
 - (vi) Location of any dedicated asphalt or concrete batch plants.
 - (vii) Location of construction offices and staging areas.
 - (viii) Location of work access routes during construction.
 - (ix) Location of borrow and waste.
 - (x) Location of temporary, interim and permanent stabilization.
 - (xi) Location of outfalls.
 - (xii) Arrows showing direction of surface flow.

- (xiii) Structural and non-structural BMPs.
 - (xiv) LDA and LOC lines as defined in subsection 107.25.
- (8) Amend the SWMP whenever there are: additions, deletions, or changes to BMPs. SWMP revisions shall be recorded immediately. Items shall be dated and initialed by the SWMP Administrator. Specifically, amendments shall include the following:
- (i) A change in design, construction, operation, or maintenance of the site which would require the implementation of new or revised BMPs; or
 - (ii) Changes when the SWMP proves to be ineffective in achieving the general objectives of controlling pollutants in stormwater discharges associated with construction activity.
 - (iii) Changes when BMPs are no longer necessary and are removed.
- (9) Complete vegetative survey transects when required in accordance with CDOT Erosion Control and Stormwater Quality Guide.
- (10) Start a new site map before the current one becomes illegible. All site maps shall remain in the SWMP notebook.
- (11) Document all inspection and maintenance activities. The SWMP and documentation shall be kept on the project site.
- (12) When adding or revising BMPs on the SWMP, add a narrative explaining what, when, where, why, and how the BMP is being used, and add a detail to the SWMP notebook.
- (i) How to install and inspect the BMP.
 - (ii) Where to install the BMP.
 - (iii) When to maintain the BMP.
- (13) If using existing topography, vegetation, etc. as a BMP, label it as such on the SWMP site map; add a narrative as to when, where, why, and how the BMP is being used.
- (14) Indicate BMPs in use or not in use by recording them on Standard Plans M-208-1, M-216-1, and M-615-1 in the SWMP notebook.
- (15) Record on the SWMP, the approved Method Statement for Containing Pollutant Byproducts.
- (16) Update the potential pollutants list in the SWMP notebook and Spill Response Plan throughout construction.

2. Erosion Control Inspection.

Erosion control inspection shall be performed by TECS certified staff assigned as Erosion Control Inspector (ECI) to the project. One ECI is required for every 40 acres of total disturbed area which is currently receiving temporary and interim stabilization measures as defined in subsection 208.04(e). An ECI shall not be responsible for more than 40 acres on the project. Accepted permanent stabilization methods as defined in subsection 208.04(e) will not be included in the 40 acres.

ECI duties shall be as follows:

- (1) Coordinate with the SWMP Administrator on reporting the results of inspections.
- (2) Review the construction site for compliance with the Stormwater Construction Permit.
- (3) Inspect with the Superintendent and the Engineer (or their designated representatives) the stormwater management system at least every seven calendar days. Post-storm event inspections shall be conducted within 24 hours after the end of any precipitation or snow melt event that may cause surface erosion. If no construction activities will occur following a storm event, post-storm event inspections shall be conducted prior to commencing construction activities, but no later than 72 hours following the storm event. The occurrence of delay in inspections shall be documented in the inspection report. Form 1176 shall be used for all 7 day inspections and inspections following storm events. The Contractor shall notify the Erosion Control Inspector when a storm event occurs. Failure to perform inspections on time will result in liquidated damages in accordance with subsection 208.09.

Inspections are not required at sites when construction activities are temporarily halted, when snow cover exists over the entire site and melting conditions do not pose a risk of surface erosion. This exception shall be applicable only during the period where melting conditions do not exist, and applies to the routine 7 day, Headquarters and Region inspections, as well as the post-storm event inspections. The following information shall be documented on Form 1176 for use of this exclusion: dates when snow cover occurred, date when construction activities ceased, and date melting conditions began.

The order of precedence for required inspections shall be as follows:

- (i) Headquarter water quality inspections
- (ii) Region water quality inspections

(iii) Post-storm event inspections

(iv) 7 day inspections

When one of the listed inspections is performed, the inspections listed below it need not be performed on that day if the required CDOT and Contractor personnel participated in the inspection.

For example: A 7 day inspection is not required on the same day a headquarters or Region inspection is conducted. A sheet shall be placed in the inspections area of the SWMP Notebook to refer to the date inspection was performed.

- (4) Follow all other agency Stormwater requirements and inspections unless a waiver or other agreement has been made.
- (5) Immediately report to the Contractor's Superintendent and the SWMP Administrator the following instances of noncompliance:
- (i) Noncompliance which may endanger health or the environment.
 - (ii) Spills or discharges of hazardous substance or oil which may cause pollution of waters of the State.
 - (iii) Discharge of stormwater which may cause an exceedance of a water quality standard.
 - (iv) Upset conditions that occur on site.
- (6) Document spills, leaks, or overflows that result in the discharge of pollutants on the Form 1176. The ECI shall record the time and date, weather conditions, reasons for spill, and how it was remediated.
- (d) *Documentation Available on the Project.* The following Contract documents and references will be made available for reference at the CDOT field office during construction:
1. SWMP Notebook. The Engineer will provide a SWMP Notebook at the Pre-construction Conference, which is and shall remain the property of CDOT. CDOT will initially provide the documentation for the first four items when available. The Contractor shall provide the contents required for items (5) through (18). The notebook shall be stored in the CDOT field office or at another on-site location approved by the Engineer. The SWMP Administrator shall modify and update the notebook as needed to reflect actual site conditions prior to the change or as soon as practicable, but in no case more than 72 hours after the change. The following Contract documents and reports shall be kept, maintained, and updated in the notebook under the appropriate items by the SWMP Administrator:

- (1) SWMP Plan Sheets – Notes, tabulation, sequence of major activities, area of disturbance, existing soil data, existing vegetation percent cover, potential pollutant sources, receiving water, non-stormwater discharges, and environmental impacts.
- (2) Site Map and Plan Title Sheet – Construction site boundaries, ground surface disturbance, limits of cut and fill, flow arrows, structural BMPs, non-structural BMPs, Springs, Streams, Wetlands, and surface water. Also included on the sheets is the protection of trees, shrubs, and cultural resources.
- (3) Specifications – Standard and project special provisions related to stormwater and erosion control.
- (4) Standard Plans M-208-1, M-216-1 and M-615-1.
- (5) BMP Details not in Standard Plan M-208-1 – Non-standard details.
- (6) Weekly meeting sign in sheet.
- (7) Calendar of Inspections – Calendar of inspections marking when all inspections take place.
- (8) Form 1176 – Weekly meeting notes and inspection report
- (9) Region and Headquarter Water Quality Reports and Form 105(s) relating to Water Quality.
- (10) Description of Inspection and Maintenance Methods – Description of inspection and maintenance methods implemented at the site to maintain all BMPs identified in the SWMP and items not addressed in the design.
- (11) Spill Response Plan – Reports of reportable spills submitted to CDPHE.
- (12) List and Evaluation of Potential Pollutants – List of potential pollutants as described in subsection 107.25 and approved Method Statement for Containing Pollutant Byproducts.
- (13) Other Correspondence e.g., agreements with other MS4s, approved deferral request, CDPHE audit documentation, Water Quality Permit Transfer to Maintenance Punch List, and other miscellaneous documentation.
- (14) TECS Certifications of the SWMP Administrator and all ECIs, kept current through the life of the project.
- (15) Environmental Pre-construction Conference – Conference agenda with a certification of understanding of the terms and conditions of

the CDPS-SCP and SWMP. The certification shall be signed by all attendees. A certification shall also be signed by all attendees of meetings held for new subcontractors beginning work on the project that could adversely affect water quality after the Environmental Pre-construction Conference has been held.

- (16) All Project Environmental Permits – All project environmental permits and associated applications and certifications, including, CDPS-SCP, Senate Bill 40, USACE 404, temporary stream crossings, dewatering, biological opinions, and all other permits applicable to the project, including any separate CDPS-SCP obtained by the Contractor for staging area on private property, asphalt or concrete plant, etc.
- (17) Photographs Documenting Existing Vegetation – Project photographs shall be time stamped on paper with a maximum of four colored images per 8 ½ inch by 11 inch sheet and/or a digital copy of all photographs on CD-ROM/Flash Drive in (JPG format), documenting existing vegetation prior to construction commencing. On the bottom of each photograph shall be a description using Station Number or Mile Post where the photograph was taken.
- (18) Permanent Water Quality Plan Sheets – Plan sheets and specifications for permanent water quality structures and riprap.

The Engineer will incorporate the documents and reports available at the time of award. The Contractor shall provide and insert all other documents and reports as they become available during construction. The SWMP Administrator shall finalize the SWMP for CDOT Maintenance use upon completion of the project. SWMP completeness shall be approved by the Engineer. Corrections to the SWMP shall be made at the Contractor's expense.

2. Reference Materials. The following Reference materials shall be used:

- (1) CDOT Erosion Control and Stormwater Quality Guide.
- (2) CDOT Erosion Control and Stormwater Quality Field Guide.

- (e) *Weekly Meetings*: The Engineer, the Superintendent, and the SWMP Administrator shall conduct a weekly meeting with supervisors involved in construction activities that could adversely affect water quality. The meeting shall follow an agenda prepared by the Engineer, or a designated representative, and have a sign in sheet on which the names of all attendees shall be recorded. The SWMP Administrator shall take notes of water quality comments and action items at each weekly meeting, and place the agenda and sign in sheet in the SWMP notebook. At this meeting the following shall be discussed and documented on Form 1176:

- (1) Requirements of the SWMP.
- (2) Problems that may have arisen in implementing the site specific SWMP or maintaining BMPs.
- (3) Unresolved issues from inspections and concerns from last inspection
- (4) BMPS that are to be installed, removed, modified, or maintained.
- (5) Planned activities that will affect stormwater in order to proactively phase BMPs.
- (6) Recalcitrant inspection findings.

All subcontractors who were not in attendance at the Environment Pre-construction Conference shall be briefed on the project by the Engineer, Superintendent, and the SWMP Administrator prior to start of work. The SWMP Administrator shall record the names of these subcontractors as an addendum to the list of attendees, and add it to the SWMP Notebook.

208.04 Best Management Practices for Stormwater.

The SWMP Administrator shall modify the SWMP to clearly describe and locate all BMPs implemented at the site to control potential sediment discharges.

Vehicle tracking control shall be used at all vehicle and equipment exit points from the site to prevent sediment exiting the limits of construction (LOC) of the project site. Access shall be provided only at locations approved by the Engineer. The SWMP Administrator shall record vehicle tracking control pad locations on the SWMP site map.

New inlets and culverts shall be protected during their construction. Appropriate protection of each culvert and inlet shall be installed immediately. When riprap is called for at the outlet of a culvert, it shall be installed within 24 hours of completion of each pipe. The Contractor shall remove sediment, millings, debris, and other pollutants from within the newly constructed drainage system in accordance with the CDPS-SCP, prior to use, at the Contractor's expense. All removed sediment shall be disposed of outside the project limits in accordance with all applicable regulations.

Concrete products wasted on the ground during construction including, but not limited to, excess concrete removed from forms, spills, slop, and all other unused concrete are potential pollutants that shall be contained or protected by an approved BMP at a pre-approved containment area. The concrete shall be picked up and recycled in accordance with 6 CCR 1007-2 (CDPHE Regulations Pertaining to Solid Waste Sites and Facilities) at regular intervals, as directed. The uses of recycled concrete from permitted recycling facilities shall be in accordance with Section 203.

- (a) *Unforeseen Conditions.* The Contractor shall design and implement erosion and sediment BMPs for correcting conditions unforeseen during the design of the project, or for emergency situations, that develop during construction. The Department's Erosion Control and Stormwater Quality Guide shall be used as a reference document for the purpose of designing erosion and sediment

BMPs. Measures and methods proposed by the Contractor shall be reviewed and approved in writing by the Engineer prior to installation.

- (b) *Other Agencies.* If CDPHE, US Army Corps of Engineers (USACE), or the Environmental Protection Agency (EPA) reviews the project site and requires additional measures to prevent and control erosion, sediment, or pollutants, the Contractor shall cease and desist activities resulting in pollutant discharge and immediately implement these measures. If the work may negatively affect another MS4, the Contractor shall cease and desist activities resulting in the discharge and shall implement appropriate measures to protect the neighboring MS4, including installing additional measures. Implementation of these additional measures will be paid for at contract unit prices.
- (c) *Work Outside the Right of Way.* Disturbed areas, including staging areas, which are outside CDOT ROW and outside easements acquired by CDOT for construction, are the responsibility of the Contractor. These areas may be subject to a separate CDPS-SCP or other permits. The Contractor shall acquire these permits and submit copies to the Engineer prior to any disturbance. These permits, shall be acquired and all erosion and sediment control work performed at the Contractor's expense. These areas are subject to inspections by CDOT or any other agency, as agreed upon in writing. *Construction Implementation.* The Contractor shall incorporate BMPs into the project as outlined in the accepted schedule.
- (d) *Stabilization.* Once earthwork has started, the Contractor shall maintain erosion BMPs until permanent stabilization of the area has been completed and accepted. Clearing, grubbing and slope stabilization measures shall be performed regularly to ensure final stabilization. Failure to properly maintain erosion control and stabilization methods, either through improper phasing or sequencing will require the Contractor to repair or replace sections of earthwork at his expense. The Contractor shall schedule and implement the following stabilization measures during the course of the project:
 - 1. *Temporary Stabilization.* At the end of each day, the Contractor shall stabilize disturbed areas by surface roughening, vertical tracking, or a combination thereof. Disturbed areas are locations where actions have been taken to alter the existing vegetation or underlying soil of a site, such as clearing, grading, road bed preparation, soil compaction, and movement and stockpiling of top soils. Other stabilization measures may be implemented, as approved. The maximum area of temporary stabilization shall not exceed 20 acres
 - 2. *Interim Stabilization.* As soon as it is known with reasonable certainty that work will be temporarily halted for 14 days or more, stockpiles and disturbed areas shall be stabilized using one or more of the specified following methods:

- (1) Application of 1.5 tons per acres of mechanically crimped certified weed free hay or straw in combination with an approved organic mulch tackifier.
 - (2) Placement of bonded fiber matrix in accordance with Section 213.
 - (3) Placement of mulching (hydraulic) wood cellulose fiber mulch with tackifier, in accordance with Section 213.
 - (4) Application of spray-on mulch blanket in accordance with Section 213. Magnesium Chloride, Potassium Chloride and Sodium Chloride, or other salt products, shall not be used as a stabilization method.
3. Summer and Winter Stabilization. Summer and winter stabilization is defined as stabilization during months when seeding will not be permitted. As soon as the Contractor knows shutdown is to occur, interim stabilization shall be applied to the disturbed area. Protection of the interim stabilization method is required. Reapplication of interim stabilization may be required as directed.
 4. Permanent Stabilization. Permanent stabilization is defined as the covering of disturbed areas with seeding, mulching with tackifier, soil retention coverings, and such non-erodible methods as riprap, road shouldering, etc., or a combination thereof as required by the Contract. Other permanent stabilization techniques may be proposed by the Contractor, in writing, and shall be used when approved in writing by the Engineer. Permanent stabilization shall begin within 48 hours after topsoil placement, soil conditioning, or combination thereof starts and shall be pursued to completion.
 5. Final Stabilization. Final stabilization is achieved when all ground disturbing activities at the site have been completed, and uniform vegetative cover has been established with an individual plant density of at least 70 percent of pre-disturbance levels, or equivalent permanent physical erosion reduction methods have been employed.
- (e) *Maintenance.* Erosion and sediment control practices and other protective measures identified in the SWMP as BMPs for stormwater pollution prevention shall be maintained in effective operating condition until the CDPS-SCP has been transferred to CDOT. BMPs shall be continuously maintained in accordance with good engineering, hydrologic, and pollution control practices, including removal of collected sediment when silt depth is 50 percent or more of the height of the erosion control device. When possible, the Contractor shall use equipment with an operator rather than labor alone to remove the sediment.

Maintenance of erosion and sediment control devices shall include replacement of such devices upon the end of their useful service life as recommended by the Contractor and approved by the Engineer. Maintenance of rock check dams and vehicle tracking pads shall be limited to removal and

disposal of sediment or addition of aggregate. Damages resulting from failure to maintain BMPs shall be repaired at the Contactors expense.

Complete site assessment shall be performed as part of comprehensive inspection and maintenance procedures to assess the adequacy of BMPs at the site and the necessity of changes to those BMPs to ensure continued effective performance. Where site assessment results in the determination that new or replacement BMPs are necessary, the BMPs shall be installed to ensure continuous effectiveness. When identified, BMPs shall be maintained, added, modified or replaced as soon as possible, immediately in most cases.

Approved new or replaced BMPs will be measured and paid for in accordance with subsections 208.11 and 208.12. Devices damaged due to the Contractor's negligence shall be replaced at the Contractor's expense.

From the time seeding and mulching work begins until project acceptance the Contractor shall maintain all seeded areas. Damage to seeded areas or to mulch materials shall be immediately restored. Damage to seeded areas or to mulch materials due to Contractor negligence shall be immediately restored at the Contractor's expense. Restoration of other damaged areas will be measured and paid for under the appropriate bid item.

Temporary BMPs may be removed upon completion of the project, as determined by the Water Quality Partial Acceptance walk-through. If removed, the area in which these BMPs were constructed shall be returned to a condition similar to that which existed prior to its disturbance. Removed BMPs shall become the property of the Contractor.

If a project delay occurs, the Contractor shall continue erosion and sediment control operations beyond the original contract time.

Sediment removed during maintenance of BMPs and material from street sweeping may be used in or on embankment, provided it meets the requirements of Section 203 and is distributed evenly across the embankment.

Whenever sediment collects on the paved surface, the surface shall be cleaned. Street washing will not be allowed. Storm drain inlet protection shall be in place prior to shoveling, sweeping, or vacuuming. Sweeping shall be completed with a pickup broom or equipment capable of collecting sediment. Sweeping with a kick broom will not be allowed.

Material from pavement saw cutting operations shall be cleaned from the roadway surface during operations using a vacuum. A BMP, such as a berm, shall be placed to contain slurry from joint flushing operations until the residue can be removed from the soil surface. Aggregate bags, erosion logs or other permeable BMPs shall not be used. Residue shall not flow into driving lanes. It shall be removed and disposed of in accordance with subsection 107.25(b)13. Material containment and removal will not be paid for separately, but shall be included in the work.

208.05 Construction of BMPs. BMPs shall be constructed in accordance with Standard Plans M-208-1 and M-216-1 and with the following. *Seeding, Mulching, Sodding, Soil Retention Blanket.* Seeding, mulching, sodding, and soil retention blanket installation shall be performed in accordance with Sections 212, 213, and 216.

- (b) *Erosion Bales.* The bales shall be anchored securely to the ground with wood stakes.
- (c) *Silt Fence.* Silt fence shall be installed in locations specified in the Contract prior to any grubbing or grading activity.
- (d) *Temporary Berms.* Berms shall be constructed to the dimensions shown in the Contract, and sufficiently compacted to prevent erosion or failure. If the berm erodes or fails, it shall be immediately repaired or replaced at the Contractor's expense.
- (e) *Temporary Diversion.* Diversions shall be constructed to the dimensions shown in the Contract and graded to drain to a designated outlet. The berm shall be sufficiently compacted to prevent erosion or failure. If the diversion erodes or fails, it shall be immediately repaired or replaced at the Contractor's expense.
- (f) *Temporary Slope Drains.* Temporary slope drains shall be installed prior to installation of permanent facilities or growth of adequate ground cover on the slopes. All temporary slope drains shall be securely anchored to the slope. The inlets and outlets of temporary slope drains shall be protected to prevent erosion.
- (g) *Silt Berm.* Prior to installation of silt berms, the Contractor shall prepare the surface of the areas in which the berms are to be installed such that they are free of materials greater than 2 inches in diameter and are suitably smooth for the installation of the silt berms, as approved. Silt berms shall be secured with spikes. The Contractor shall install the silt berm in a manner that will prevent water from going around or under the silt berm. Silt berms shall be installed on top of soil retention blanket.
- (h) *Rock Check Dam.* Rock shall be installed at locations shown on the plans. Rock check dams shall conform to the dimensions shown on the plans.
- (i) *Rip rap Outlet Protection.* Geotextile used shall be protected from cutting or tearing. Overlaps between two pieces of geotextile shall be 1 foot minimum. Riprap size shall be as shown on the plans.
- (j) *Storm Drain Inlet Protection.* Prior to installation, the Contractor shall sweep the surface of the area in which the storm drain inlet protection devices are to be installed such that the pavement is free of sediment and debris. The ends of the inlet protection Type 1 and Type 2 shall extend a minimum of 1 foot past each end of the inlet.

The Contractor shall remove all accumulated sediment and debris from the

surface surrounding all storm drain inlet protection devices after each rain event or as directed. The Contractor shall remove accumulated sediment from each Type II and III containment area when it is more than one third full of sediment, or as directed.

The Contractor shall protect storm drain facilities adjacent to locations where pavement cutting operations involving wheel cutting, saw cutting, sand blasting, or abrasive water jet blasting are to take place.

- (k) *Sediment Trap*. Sediment traps shall be installed to collect sediment laden water and to minimize the potential of pollutants leaving the project site. Locations shall be as shown on the plans or as directed.

Sediment traps shall be constructed prior to disturbance of upslope areas and shall be placed in locations where runoff from disturbed areas can be diverted into the trap.

The area under the embankment shall be cleared, grubbed, and stripped of any vegetation and roots.

Fill material for the embankment shall be free of roots or other vegetation, organic material, large stones, and other objectionable material.

Sediment shall be removed from the trap when it has accumulated to one half of the wet storage depth of the trap and shall be disposed of in accordance with subsection 208.04(f).

- (l) *Erosion Logs*. Erosion logs shall be embedded 2 inches into the soil. Stakes shall be embedded to a minimum depth of 12 inches. At the discretion of the Engineer, a shallower depth may be permitted if rock is encountered.

The Contractor shall maintain the erosion logs during construction to prevent sediment from passing over or under the logs.

- (m) *Silt Dikes*. Prior to installation of silt dikes, the Contractor shall prepare the surface of the areas in which the silt dikes are to be installed such that they are free of materials greater than two inches in diameter and are suitably smooth for the installation of the silt dikes, as approved by the Engineer.

- (n) *Concrete Washout Structure*. The concrete washout structure shall meet or exceed the dimensions shown on the plans and be used in accordance with manufacturer's recommendations. Work on this structure shall not begin until written acceptance is provided by the Engineer.

Concrete washout structure shall conform to Standard Plan M-208-1 and shall meet the following requirements:

- (1) The structure shall contain all washout water.

- (2) Stormwater shall not carry wastes from washout and disposal locations.
- (3) The site shall be located a minimum of 50 horizontal feet from State waters and shall meet all requirements for containment and disposal as defined in subsection 107.25.
- (4) The site shall be signed as "Concrete Washout".
- (5) The site shall be accessible to appropriate vehicles.
- (6) Freeboard capacity shall be included in the structure design to reasonably ensure the structure will not overtop during or because of a precipitation event.
- (7) The Contractor shall prevent tracking of washout material out of the washout structure.
- (8) Solvents, flocculents, and acid shall not be added to wash water.
- (9) The structure shall be surrounded on three sides by a compacted berm.
- (10) The structure shall be fenced with orange plastic construction fencing to provide a barrier to construction equipment and to aid in identification of the concrete washout area.
- (11) Concrete waste, liquid and solid, shall not exceed $\frac{2}{3}$ the storage capacity of the washout structure.

Pre-fabricated concrete washout structures shall meet the following requirements:

- (1) Structure shall contain all washout water.
- (2) Structure shall be located 50 horizontal feet away from State waters, and shall be confined so that no potential pollutants will enter State waters and other sensitive areas as defined in the Contract. Locations shall be as approved by the Engineer. The site shall be delineated with orange plastic fence or other means and signed as "Concrete Washout".
- (3) The site shall be accessible to appropriate vehicles.
- (4) Freeboard capacity shall be included in structure design to reasonably ensure the structure will not overtop during or because of a precipitation event.
- (5) Solvents, flocculants, and acid shall not be added to wash water.
- (6) Concrete waste, liquid and solid, shall not exceed $\frac{2}{3}$ the storage capacity of the washout structure.

- (7) Prefabricated structures cannot be moved when they contain liquid, unless otherwise approved.
- (8) The concrete washout structure shall be completed and ready for use prior to concrete placement operations.
- (9) Washout areas shall be checked and maintained as required. On site permanent disposal of concrete washout waste is not allowed.

All liquid and solid wastes, including contaminated sediment and soils generated from concrete washout shall be hauled away from the site and disposed of properly at the Contractor's expense.

- (o) *Vehicle Tracking Pad (VTP)*. Vehicle tracking pads shall be constructed to the minimum dimensions shown in the Contract, unless otherwise directed by the Engineer. Construction of approved vehicle tracking pads shall be completed before any disturbance of the area.

The Contractor shall maintain each vehicle tracking pad during the entire time that it is in use for the project. The vehicle tracking pad shall be removed at the completion of the project unless otherwise directed by the Engineer. Additional aggregate may be required for maintenance and will be paid for under Pay Item, Maintenance Aggregate (Vehicle Tracking Pad).

- (p) *Detention Pond*. Permanent detention ponds shown on the construction plans may be used as temporary BMPs if all the following conditions are met:
 - (1) The pond is designated as a construction BMP in the SWMP.
 - (2) The pond outfall and outlet are designed and implemented for use as a BMP during construction in accordance with good engineering, hydrologic, and pollution control practices. The stormwater discharges from the outfall shall not cause degradation or pollution of State waters, and shall have BMPs, as appropriate.
 - (3) All silt shall be removed and the pond returned to the design grade and contour prior to project acceptance.
- (q) *Aggregate Bag*. Aggregate bags shall be placed on a stable surface, consisting of pavement, grass or gravel. Aggregate bags shall be placed to conform to the surface without gaps. Discharge water shall not cause erosion.
- (r) *Surface roughening*. Surface roughening creates horizontal grooves along the contour of the slope. Roughening may be accomplished by furrowing, scarifying, ripping, or disking the soil surface to create a 2 to 4 inch minimum variation in soil surface. Surface roughening will not be paid for separately, but shall be included in the work.
- (s) *Vertical Tracking*. Vertical tracking involves driving a tracked vehicle up and down the soil surface and creating horizontal grooves and ridges along the

contour of the slope. Sandy soils or soils that are primarily rock need not be tracked. Vertical tracking will not be paid for separately, but shall be included in the work.

208.06 Materials Handling and Spill Prevention. The SWMP Administrator shall clearly describe and record on the SWMP, all practices implemented at the site to minimize impacts from procedures or significant material that could contribute pollutants to runoff. Areas or procedures where potential spills can occur shall have a Spill Response Plan in place as specified in subsections 107.25(b) 6 or 208.06(c). Construction equipment, fuels, lubricants, and other petroleum distillates shall not be stored or stockpiled within 50 horizontal feet of any State waters or more if the Contractor determines necessary. Equipment fueling and servicing shall occur only within approved designated areas.

- (a) Bulk storage structures for petroleum products and other chemicals shall have impervious secondary containment or equivalent adequate protection so as to contain all spills and prevent any spilled material from entering State waters. Secondary containment shall be capable of containing the combined volume of all the storage containers plus at least 10 percent freeboard. For secondary containment that is used and may result in accumulation of stormwater within the containment, a plan shall be implemented to properly manage and dispose of all accumulated stormwater which is deemed to be contaminated (e.g., has an unusual odor or sheen).
- (b) *Lubricant Leaks.* The Contractor shall inspect equipment, vehicles, and repair areas daily to ensure petroleum, oils, and lubricants (POL) are not leaking onto the soil or pavement. Absorbent material or containers approved by the Engineer shall be used to prevent leaking POL from reaching the soil or pavement. The Contractor shall have onsite approved absorbent material or containers of sufficient capacity to contain any POL leak that can reasonably be foreseen. The Contractor shall inform all Spill Response Coordinators in accordance with the Spill Response Plan if unforeseen leakage is encountered. All materials resulting from POL leakage control and cleanup shall become the property of the Contractor and shall be removed from the site. Control, cleanup, and removal of by-products resulting from POL leaks shall be performed at the Contractor's expense.
- (c) *Spill Response Plan.* A spill Response Plan shall be developed and implemented to establish operating procedures for handling potential pollutants and preventing spills.

The Response Plan shall contain the following information:

- (1) Identification and contact information of each Spill Response Coordinator.
- (2) Locations of areas on the project site where equipment fueling and servicing operations are permitted.
- (3) Location of cleanup kits.

- (4) Quantities of chemicals and locations stored on site.
- (5) Label system for chemicals and Safety Data Sheets (SDS) for products.
- (6) Clean up procedures to be implemented in the event of a spill that does not enter State waters or ground water.
- (7) Procedures for spills of any size that enter surface waters or ground water, or have the potential to do so. CDOT's Erosion Control and Stormwater Quality Guide contains spill notification contacts and phone numbers required in the Spill Response Plan.
- (8) A summary of the employee training provided.

Information in items (1) through (8) shall be updated in the SWMP Notebook when they change.

208.07 Stockpile Management. Material stockpiles shall be located 50 horizontal feet away from State waters, and shall be confined so that no potential pollutants will enter State waters and other sensitive areas as defined in the Contract. Locations shall be approved by the Engineer. Erodible stockpiles (including topsoil) shall be contained with acceptable BMPs at the toe (or within 20 feet of the toe) throughout construction. BMPs shall be approved by the Engineer. The SWMP Administrator shall describe, detail, and record the sediment control devices on the SWMP.

208.08 Limits of Disturbance. The Contractor shall limit construction activities to those areas within the limits of disturbance shown on the plans and cross-sections. Construction activities, in addition to the Contract work, shall include the on-site parking of vehicles or equipment, on-site staging, on-site batch plants, haul roads or work access, and all other activities which would disturb existing soil conditions. Staging areas within the LDA shall be as approved by the Engineer. Construction activities beyond the limits of disturbance due to Contractor negligence shall be restored to the original condition by the Contractor at the Contractor's expense. The SWMP Administrator shall tabulate additional disturbances not identified in the CDPS-SCP application and indicate changes to locations and quantities on the SWMP. The Contractor shall report the changes and additional disturbances to the Engineer, Water Quality Control Division of CDPHE, and all other involved agencies.

The Contractor shall pursue stabilization of all disturbances to completion.

208.09 Failure to Perform Erosion Control. Failure to implement the Stormwater Management Plan is a violation of the CDPS-SCP and CDOT specifications. CDOT is obligated to implement enforcement mechanisms in accordance with CDOT's MS4 Permit COS000005 for Stormwater Management and erosion control Best Management Practices. Penalties may be assessed to the Contractor by the appropriate agencies. Penalties will be assessed by the Department as liquidated damages for failure to meet the Permit. All fines assessed to the

Department for the Contractor's failure to implement the SWMP will be deducted from moneys due the Contractor in accordance with subsection 107.25(d) 2.

The Contractor will be subject to liquidated damages for incidents of failure to perform erosion control as required by the Contract. Liquidated damages will be applied for failure to comply with the CDPS-SCP and these specifications, including the following:

- (1) Failure to include erosion control in the project schedule or failure to include erosion control in each schedule update as specified in subsection 208.03(b).
- (2) Failure of the Contractor to perform the inspections required by subsection 208.03(c) 2.
- (3) Failure of the Contractor to implement necessary actions required by the Engineer as required by subsection 208.03(c).
- (4) Failure to amend the SWMP and implement BMPs as required by subsection 208.04.
- (5) Failure to keep documentation and records current.
- (6) Failure to construct or implement erosion control or spill containment measures required by the Contract, or failure to construct or implement them in accordance with the Contractor's approved schedule as required by subsection 208.06(c).
- (7) Failure to limit temporary stabilization to 20 or fewer acres as required by subsection 208.04 (e).
- (8) Failure to replace or perform maintenance on an erosion control feature after notice from the Engineer or from a water quality inspection as required by subsection 208.04(f).
- (9) Failure to remove and dispose of sediment from BMPs as required.
- (10) Failure to install and properly utilize a concrete washout structure for containing washout from concrete placement operations.
- (11) Failure to perform stabilization as required by subsection 208.04(e).
- (12) Failure of the Superintendent or designated representative to attend inspections as required by subsection 208.03(c) and record findings in the appropriate form.
- (13) Failure to prevent discharges not composed entirely of stormwater from leaving the Construction Site.
- (14) Failure to provide the survey of Permanent Water Quality BMPs when required on the project in accordance with 208.10.

The Engineer will immediately notify the Contractor of each incident of failure to perform erosion control in accordance with the CDPS-SCP and these specifications, including items (1) through (14) above by issuing a Form 105. Correction shall be made as soon as possible but no later than 48 hours from the date of notification to correct the failure. The Contractor will be charged liquidated damages in the amount of \$970 for each day after the 48 hour period has expired that one or more of the incidents of failure to perform the requirements for each Form 105 remains uncorrected. Liquidated damages will begin at Midnight of the date the 48 hours has expired.

This deduction will not be considered a penalty, but will be considered liquidated damages based on estimated additional construction engineering costs. The liquidated damages will accumulate, for each cumulative day that one or more of the incidents remain uncorrected. The number of days for which liquidated damages are assessed will be cumulative for the duration of the project; that is: the damages for a particular day will be added to the total number of days for which liquidated damages are accumulated on the project. The liquidated damages will be deducted from any monies due the Contractor.

If all other failures are not corrected within 48 hours after liquidated damages have begun to be assessed, the Engineer will issue a Stop Work Order in accordance with subsection 105.01. Work shall not resume until the Engineer has approved a written corrective action plan submitted by the Contractor that includes measures to prevent future violations and a schedule for implementation.

If the Contractor requires more than 96 hours to perform the corrective work from the date on the Form 105, the Contractor shall submit a request for deferment. The deferment request shall be in writing and shall include the specific failure, temporary measures until final correction is made, the methodology which will be employed to make the correction, and interim milestones to completing the work. The Region Water Pollution Control Manager (RWPCM), Engineer, the SWMP Administrator, and the Contractor shall concur on this deferral and set a proposed date of completion. If approved, the Contractor shall complete the corrective measures by Midnight of the proposed completion date. If corrective work is not corrected by the completion date the Engineer will issue a Stop Work Order. Liquidated Damages will apply retroactively back to the 48 hours after the Form 105 date of notification. Liquidated Damages will be assessed until the corrective work has been completed and accepted.

Deferment of work to correct failures to perform erosion control will not affect the Contractor's other contractual responsibilities, notifications for other non-compliance, nor the final completion date of the project. Liquidated Damages for other non-compliance notifications will continue to apply during the deferment period in addition to liquidated damages associated with the deferment.

Based on the submittal date of the approved deferment Liquidated Damages and a Stop Work Order may not be mandated to the Contractor.

Disagreements regarding the suggested corrective action for a BMP compliance issue between the Project Engineer, SWMP Administrator, and Superintendent, shall be discussed with the Resident Engineer and Region Water Pollution Control Manager. If after the discussions, the Project Engineer and the Contractor are still

in disagreement and the Contractor believes that additional compensation is owed, the Contractor will follow the decision of the Project Engineer, keep track of the costs and negotiate further with the Project Engineer. If after pursuing the issue, the Contractor is unable to reach agreement with the Project Engineer, then the Contractor can follow the dispute process outlined in subsection 105.22.

If the Contractor's corrective action plan and schedule are not submitted and approved within 96 hours of the initial notice, the Engineer will issue a Stop Work Order and have an on-site meeting with the Superintendent, SWMP Administrator, and the Superintendent's supervisor. This meeting will also be attended by the Resident Engineer, the Region Water Pollution Control Manager, and the Region Program Engineer. This meeting will identify and document needed corrective actions and a schedule for completion. If after the meeting, the unacceptable work is not remedied within the schedule as agreed to in the meeting, the Engineer will take action to effect compliance with the CDPS-SCP and these specifications by utilizing CDOT Maintenance personnel or other non-Contractor forces and deduct the cost from any moneys due or to become due to the Contractor pursuant to subsection 105.17. Delays due to these Stop Work Orders shall be considered non-excusable. The Stop Work Order shall be in place until the project is in CDPS-SCP compliance.

If the Contractor remains non-responsive to requirements of the on-site meeting, the Engineer will start default or Contract termination procedures in accordance with subsections 108.09 and 108.10. CDOT will proceed with corrective or disciplinary action in accordance with the Rules for Prequalification, Debarment, Bidding and Work on Transportation, Road, Highway and Bridge Public Projects.

When a failure meets any one of the following conditions, the Engineer will immediately issue a Stop Work Order in accordance with subsection 105.01 irrespective of any other available remedy:

- (1) It may endanger health or the environment.
- (2) It consists of a spill or discharge of hazardous substances or oil which may cause pollution of the waters of the state.
- (3) It consists of a discharge which may cause a violation of a water quality standards.

208.10 Items to Be Completed Prior to Requesting Partial Acceptance of Water Quality Work.

- (a) *Reclamation of Washout Areas.* After concrete operations are complete, washout areas shall be reclaimed in accordance with subsection 208.05(n) at the Contractor's expense.
- (b) *Survey.* When Permanent Water Quality BMPs (Permanent BMP) are required on the project, the Contractor shall survey the BMPs to confirm that they conform to the configuration and grade shown on the Plans. The survey shall conform to Section 625. The results of the survey shall be submitted as Microstation or AutoCAD drawing files and PDF files, showing both designed and final elevations and configurations. Paper versions of the drawings shall be submitted with the stamp and seal of the Contractor's Surveyor.

The Engineer and the CDOT Hydraulics Engineer for the region will perform a walkthrough of the Permanent BMPs to confirm conformance to material requirements, locations, and dimensions of the Permanent BMPs. Permanent BMPs not meeting the Contract requirements will be identified in writing by the Engineer, and shall be repaired or replaced at the Contractor's expense. Correction surveys shall be performed at the Contractor's expense to confirm the locations and dimensions of each Permanent BMP. Final as-built plans of the Permanent BMPs shall be provided to the Engineer and the CDOT Region and Headquarter Permanent Water Quality Control Specialist for their records.

- (c) *Locations of Temporary BMPs.* The Engineer will identify locations where modification, cleaning, or removal of temporary BMPs are required and will provide these in writing to the Contractor. Upon completion of work required, the SWMP Administrator shall modify the SWMP to provide an accurate depiction of BMPS to remain on the project site.

METHOD OF MEASUREMENT

208.11 Erosion Control Management will be measured as the actual number of days of ECM work performed onsite, regardless of the number of ECIs required, including erosion control inspections, documentation, meeting participation, SWMP Administration, and the preparation of the SWMP notebook.

Erosion bales will be measured by the actual number installed and accepted.

Silt fence, silt berms, erosion logs, aggregate bags, silt dikes, temporary berms, rock check dams, temporary diversions, and temporary slope drains, will be measured by the actual number of linear feet that are installed and accepted. Measured length will not include required overlap.

Concrete washout structure will be measured by the actual number of structures that are installed and accepted.

Storm drain inlet protection will be measured by linear foot or actual number of devices that are installed and accepted.

Sediment trap quantities will be measured by the actual number installed and accepted.

Removal of trash that is not generated by construction activities will be measured by the actual number of hours that Contractor workers actively remove trash from the project. Each week the Contractor shall submit to the Engineer a list of workers and the hours spent collecting such trash.

Removal of accumulated sediment from traps, basins, areas adjacent to silt fences and erosion bales, and other clean out excavation of accumulated sediment, and the disposal of such sediment, will be measured by the number of hours that equipment, labor, or both are used for sediment removal.

Vehicle tracking pads will be measured by the actual number constructed and accepted.

Additional aggregate required for maintaining vehicle tracking pads will be measured as the actual number of cubic yards installed and accepted.

BASIS OF PAYMENT

208.12 ECM and BMPs will be paid for at the Contract unit price for each of the items listed below that appear in the bid schedule.

Payment will be made under:

Pay Item	Pay Unit
Aggregate Bag	Linear Foot
concrete Washout Structure	Each
Erosion Bales (Weed Free)	Each
Erosion Control Management	Day
Erosion Log (Type 1) (____ Inch)	Linear Foot
Erosion Log (Type 2) (____ Inch)	Linear Foot
Pre-Fabricated Concrete Washout Structure	Each
Pre-Fabricated Vehicle Tracking Pad	Each
Maintenance Aggregate (Vehicle Tracking Pad)	Cubic Yard
Removal and Disposal of Sediment (Equipment)	Hour
Removal and Disposal of Sediment (Labor)	Hour
Removal of Trash	Hour
Rock Check Dam	Each
Sediment Basin	Each
Sediment Trap	Each
Silt Berm	Linear Foot
Silt Dike	Linear Foot
Silt Fence	Linear Foot
Silt Fence (Reinforced)	Linear Foot
Storm Drain Inlet Protection (Type__)	Linear Foot
Storm Drain Inlet Protection (Type__)	Each
Sweeping (Sediment Removal)	Hour
Temporary Berm	Linear Foot
Temporary Diversion	Linear Foot
Temporary Slope Drain	Linear Foot
Vehicle Tracking Pad	Each

Payment for Erosion Control Management (ECM) will be full compensation for all labor, materials and equipment necessary for the SWMP Administrator and Erosion Control Inspectors to perform all the work described in this specification. This includes assembling items (5) – (18) in subsection 208.03(d)1 and required updates to the SWMP Notebook on site.

The SWMP Administrator and ECI's commute times will not be measured and paid for separately, but shall be included in the work.

Modifications to the SWMP Notebook due to construction errors or survey errors by the Contractor shall be made at the Contractor's expense.

Temporary erosion control will be measured and paid for by the BMPs used. Surface roughening and vertical tracking will not be measured and paid for separately but shall be included in the work. Payment for each BMP item will be full compensation for all work and materials required to furnish, install, maintain, and remove the BMP when directed.

Payment for Removal and Disposal of Sediment (Equipment) will be full compensation for use of the equipment, including the operator. Payment for Removal and Disposal of Sediment (Labor) will be full compensation for use of the labor.

Payment for concrete washout structure, whether constructed or prefabricated, will be full compensation for all work and materials required to install, maintain, and remove the item. Maintenance and relocation, as required, of these structures throughout the duration of the project will not be measured and paid for separately, but shall be included in the work.

Silt berm spikes will not be measured and paid for separately, but shall be included in the work. When required, soil retention blankets will be measured and paid for in accordance with Section 216. Silt dike staples will not be measured and paid for separately, but shall be included in the work.

Spray-on mulch blankets required by the Contract, including those used in both interim and final stabilization, will be measured and paid for in accordance with Section 213.

Payment for storm drain inlet protection will be full compensation for all work, materials, and equipment required to complete the item, including surface preparation, maintenance throughout the project, and removal upon completion of the work. Aggregate will not be measured and paid for separately, but shall be included in the work.

Sweeping, when used as a BMP as shown in the Contract, will be measured by the number of hours that a pickup broom or equipment capable of collecting sediment, authorized by the Engineer, is used to remove sediment from the roadway or other paved surfaces. Each week the Contractor shall submit to the Engineer a statement detailing the type of sweeping equipment used and the number of hours it was

used to pick up sediment. The operator will not be measured and paid for separately, but shall be included in the work.

Stakes, anchors, connections, geotextile, riprap, and tie downs used for temporary slope drains will not be measured and paid for separately, but shall be included in the work.

Payment for vehicle tracking pad will be full compensation for all work, materials and equipment required to construct, maintain, and remove the entrance upon completion of the work. Aggregate and geotextile will not be measured and paid for separately, but shall be included in the work. If additional aggregate for maintenance of vehicle tracking pads is required, it will be measured by the cubic yard in accordance with Section 304 and will be paid for under this Section as Maintenance Aggregate (Vehicle Tracking Pad).

Seeding, sod, mulching, soil retention blanket, and riprap will be measured and paid for in accordance with Sections 212, 213, 216, and 506.

Geotextile (Erosion Control) (Class 2) will be measured and paid for in accordance with Section 420.

All work and materials required to perform the permanent BMP survey and furnish the electronic files shall be included in the original unit price bid for surveying. Surveying will be measured and paid for in accordance with Section 625.

Payment will be made for BMPs replaced as approved by the Engineer. Temporary erosion and sediment BMPs required due to the Contractor's negligence, carelessness, or failure to install permanent controls as a part of the work as scheduled or ordered by the Engineer or for the Contractor's convenience, shall be performed at the Contractor's expense. If the Contractor fails to complete construction within the contract time, payment will not be made for Section 208 pay items for the period of time after expiration of the contract time. These items shall be provided at the Contractor's expense.

SECTION 210 RESET STRUCTURES

DESCRIPTION

210.01 This work consists of removing, relaying, resetting, or adjusting structures and related materials. All designated items shall be carefully removed, and stored, reinstalled, or adjusted, in a manner that will avoid loss or damage.

CONSTRUCTION REQUIREMENTS

210.02 General. Relaid pipe and conduit, and reset structures shall be cleaned of foreign material prior to reinstallation.

Except in areas to be excavated, all holes resulting from the removal of structures shall be neatly backfilled. Methods shall conform to those required in the specifications for the various types of construction involved.

Materials in good condition from removed structures may be re-used. Salvable material, as designated in the Contract, that is not re-used shall remain the property of the Department, and the Contractor shall be held responsible for safekeeping of all materials until receipted by the Department. Materials damaged, stolen, or lost prior to receipt by the Department shall be repaired or replaced, as determined by the Engineer, at no cost to the Department.

Unserviceable material, as determined by the Engineer, shall be replaced with new material of similar dimensions, and the material costs will be paid for in accordance with subsection 109.04(b), except as otherwise provided in this section. All new materials and replacement parts shall conform to the requirements of the Contract for the appropriate items.

210.03 Light Standard. Light standards shall be reset on new concrete foundation pads complete with conduit and wiring in accordance with the Department's Standard Plans at locations indicated in the Contract.

210.04 Fences and Gates. Where fences (except snow fence) are reset the Contractor shall supply and install any new materials required to restore the fence to acceptable condition except for new posts. The Contractor shall supply new posts as needed for the reset fence in accordance with Section 607. Wire in the old fence shall be salvaged and used in the reset fence.

Where snow fences are reset, panels shall be removed from their existing location and reset at the new location.

Gates designated to be reset shall be removed and restored for service at the new locations.

Right of way fence shall be reset approximately 6 inches inside the boundary of the highway right of way shown on the plans. Anchorages, footings, or fence

appurtenances shall not extend beyond the limits of the highway right of way without the written consent of the abutting property owner.

210.05 Guardrail. Where guardrail is reset the Contractor shall supply and install any new materials needed to restore the guardrail to acceptable condition. New materials shall include additional posts, blocks, and hardware needed to complete the intermediate post installations as shown on the Department's Standard Plans. Posts with similar tops shall be installed in groups as directed. Installation of fiat-top posts alternately with other top shapes will not be permitted. Posts may be cut, rotated, or turned upside down to eliminate unacceptable tops. If the posts are cut, the Contractor shall treat the exposed surface with two coats of an approved preservative.

Adjust guardrail shall be the work necessary to adjust the height to the standard 27 inches in accordance with Standard Plan M-606-1, and filling the resulting voids under the posts with a lean concrete mixture consisting of one part cement and ten parts sand.

210.06 Mailbox. Mailboxes complete with supporting structures are to be removed and temporarily reset at points near their original location to be accessible for mail delivery service. Upon completion of surfacing operations, the boxes shall again be reset at the locations designated. A supporting structure may contain one or more mailboxes. New permanent mailbox support posts and mounting brackets shall be furnished and installed in accordance with the Department's Standard Plans.

210.07 Ground Sign. Signs and posts designated to be reset shall be removed, cleaned, and reset at designated locations, including all work necessary to provide the existing posts with break-away devices, where required.

210.08 Sign Structure. Sign structures shall be sandblasted and repainted prior to reinstallation.

210.09 Traffic Signal. Traffic signals designated to be reset shall be removed along with existing poles and electrical equipment. New concrete footings shall be installed along with any new electrical equipment necessary to restore the structure to service at the new location. Equipment and materials shall be cleaned prior to being reset.

210.10 Adjust Structure. Adjusting structures shall apply, but not be limited to, manhole rings and covers, inlet gratings and frames, water valve boxes, water meters, gate posts, and other structures and facilities. Construction operations shall consist of raising, lowering, moving, or removing masonry or concrete; adding brick-work, masonry, or concrete; and resetting grates, frames, or rings and covers to fit the new construction. Structures in the traveled roadway shall be adjusted to a tolerance of $\frac{1}{4}$ to $\frac{1}{2}$ inch below the surface of the roadway. Work on water

services shall be subject to inspection and testing by the owners. Damage to any fire hydrant or any part of the water system by the Contractor shall be repaired at the Contractor's expense.

210.11 Flashing Beacon. Reset flashing beacon shall consist of providing a new concrete foundation or footing, adjustments of post and breakaway device as required, and providing all electrical equipment and materials necessary to restore the installation to service at the new location. The Contractor shall provide necessary connections from the nearest power source or from the source designated on the plans to the new location.

METHOD OF MEASUREMENT

210.12 The quantity to be measured where items are reset or adjusted on an “each” basis shall be the actual number of those items restored for service at new location, completed and accepted.

Concrete foundation pads will be measured and paid for as “Concrete Foundation Pad” in accordance with Section 613.

Concrete footings for ground signs and overhead sign structures, if required, will be measured and paid for in accordance with Section 614.

Steel post extensions, if required, will be measured and paid for as “Steel Sign Post” in accordance with Section 614, of the type shown on the plans.

The quantity to be measured where items are reset or adjusted on a “linear foot” basis shall be the actual number of linear feet of the items completed and accepted, measured end to end, except guardrail and snow fence. Guardrail will be measured as the actual number of linear feet completed and accepted, as shown on the Department's Standard Plans. Snow fence shall be measured end to end of the anchor posts.

The quantity to be measured for “Relay Pipe” shall be the number of linear feet of re-laid pipe including end sections, measured end to end, in place, completed and accepted.

The quantity to be measured for “Reset Mailbox Structure” shall be the number of supporting structures, complete with mailboxes, restored at new locations and accepted. Moving the mailbox structures for temporary mail service during construction, and installing new support post, base, mounting brackets, and hardware will not be measured or paid for separately but shall be included in the work.

Resetting of structures, fences, and related materials shall include all work necessary to remove the items from their existing location to the new location, and shall include all mounting hardware, footings, and all other work necessary to complete the reset item, except for new fence posts. Fence posts required and approved will be measured and paid for in accordance with Section 607.

Resetting of traffic signals, poles, controllers, cabinets, preemption units, coordination and interconnection equipment, and related equipment and materials shall include all work necessary to remove the items from their existing location and reset them at the new location, and shall include all mounting hardware, footings, other electrical equipment and service, and all other materials and work necessary to complete the reset item in service at the new location.

BASIS OF PAYMENT

210.13 The accepted quantities, measured as provided above, will be paid for at the contract price for each of the pay items listed below that appear in the bid schedule.

Payment will be made under:

Pay Item	Pay Unit
Reset	Each, Linear Foot, Square Yard, Lump Sum
Relay Pipe ()	Linear Foot
Adjust	Each, Linear Foot
Modify	Each
Reset Mailbox Structure (Type)	Each
Adjust Guardrail	Linear Foot

Structure excavation and structure backfill required for “Relay Pipe” will be measured and paid for in accordance with Section 206. Any void in the structure excavation prism created by the removal of pipe will be excluded from measurement and payment of structure excavation.

Except as otherwise provided in the Contract, collars and connecting devices will not be measured and paid for separately but shall be included in the work.

SECTION 212
SEEDING, FERTILIZER, SOIL CONDITIONER, AND
SODDING

DESCRIPTION

212.01 This work consists of soil preparation, application of fertilizer, soil conditioners, or both, and furnishing and placing seed and sod. The work shall be in accordance with the Contract and accepted horticultural practices.

MATERIALS

212.02 Seed, Soil Conditioners, Fertilizers, and Sod.

- (a) *Seed.* All seed shall be furnished in bags or containers clearly labeled to show the name and address of the supplier, the seed name, the lot number, net weight, origin, the percent of weed seed content, the guaranteed percentage of purity and germination, pounds of pure live seed (PLS) of each seed species, and the total pounds of PLS in the container. All seeds shall be free from noxious weed seeds in accordance with current state and local lists and as indicated in Section 213. The Contractor shall furnish to the Engineer a signed statement certifying that the seed is from a lot that has been tested by a recognized laboratory for seed testing within thirteen months prior to the date of seeding. The Engineer may obtain seed samples from the seed equipment, furnished bags, or containers to test seed for species identification, purity, and germination. Seed tested and found to be less than 10 percent of the labeled certified PLS and different than the specified species will not be accepted. Seed which has become wet, moldy, or damaged in transit or in storage will not be accepted.

Seed types and amount of PLS required per acre shall be provided in accordance with the Contract.

Seed and seed labels shall conform to all current State and Federal regulations and will be subject to the testing provisions of the Association of Official Seed Analysis. Computations for quantity of seed required on the project shall include the percent of purity and percent of germination.

The formula used for determining the quantity of PLS shall be:

Bulk Pounds of Seed Species • (%Purity • %Germination) = Pounds of PLS

- (b) *Soil Conditioners and Fertilizer.*

1. *Fertilizer:* Fertilizer (plant nutrients) shall conform to the applicable State fertilizer laws. It shall be uniform in composition, dry, and free flowing, and shall be delivered to the site in the original, unopened containers, each bearing the manufacturer's guaranteed analysis. Fertilizer which becomes caked or damaged will not be accepted.

2. Soil Conditioner: Soil conditioner shall consist of compost, biological nutrient, biological culture or humic acid based material.

Humic acid based material (Humate) shall include the following:

- (1) A pH of 3 to 5.
- (2) Maximum 20 percent inert ingredient.
- (3) Minimum 80 percent organic matter with 40 percent minimum humic acid.

Compost shall be weed-free, organic compost derived from a variety of feed stocks including agricultural, biosolids, forestry, food, leaf and yard trimmings, manure, tree wood with no substances toxic to plants. Material shall be aerobically composted in a facility permitted by the Colorado Department of Public Health and Environment (CDPHE) to produce or sell compost in accordance with House Bill (HB) 1181. The Contractor shall submit a copy of this permit to the Engineer for approval and the project records. The compost shall be tested in accordance with the U.S. Composting Council's Test Methods for Examining of Composting and Compost (TMECC) manual.

The compost manufacturer shall be a participating member of in the U.S. Composting Council's Seal of Testing Assurance Program (STA). The Contractor shall provide a participation certificate and test data on a Compost Technical Data Sheet.

Compost shall have the following physical properties:

Compost Parameters	Reported as	Requirement	Test Method
pH	pH units	6.0 – 8.5	TMECC 04.11-A
Soluble Salts (Electrical Conductivity)	dS m ⁻¹ or mmhos cm ⁻¹	Maximum 10dS/m	TMECC 04.10-A
Moisture Content	%, wet weight basis	30 – 60%	TMECC 03.09-A
Organic Matter Content	%, dry weight basis	30 – 65%	TMECC 05.07-A
Particle Size (sieve sizes)	%, dry weight basis for each sieve fraction	Passing 1 inch – 100% ½ inch – 95%	TMECC 02.02-B
Man-made Inert Contamination	%, dry weight basis	< 1%	TMECC 03.08-A

Compost Parameters	Reported as	Requirement	Test Method
Stability (Respirometry)	mg CO ₂ -C per g TS per day mg CO ₂ -C per g OM per day	8 or below	TMECC 05.08-B
Select Pathogens	(PASS/FAIL) Limits: Salmonella <3 MPN/4grams of TS, or Coliform Bacteria <1000 MPN/gram	Pass	TMECC 07.01-B Fecal Coliforms, or 07.02 Salmonella
Trace Metals	(PASS/FAIL) Limits (mg kg ⁻¹ , dw basis): As 41, Cd 39, Cu 1500, Pb 300, Hg 17, Ni 420, Se 100, Zn 2800	Pass	TMECC 04.06
Maturity (Bioassay)			
Percent Emergence	%, (average)	> 80%	TMECC 05.05-A
Relative Seedling Vigor	%, (average)	> 80%	
The Contractor shall provide a CTR in accordance with subsection 106.13 confirming that the material has been tested in accordance with TMECC.			

- (c) *Sod.* Sod shall be nursery grown and 99 percent weed free. Species shall be as shown on the plans. Other sod types may be used only if approved in writing by the Engineer. The one percent allowable weeds shall not include any undesirable perennial or annual grasses or plants defined as noxious by current State statute. Soil thickness of sod cuts shall not be less than $\frac{3}{4}$ inch nor more than 1 inch. Sod shall be cut in uniform strips with minimum dimensions of 18 inches in width and 48 inches in length. The Contractor shall submit a sample of the sod proposed for use, which shall serve as a standard. Any sod furnished, whether in place or not, that is not up to the standard of the sample may be rejected. Sod that was cut more than 24 hours prior to installation shall not be used.

Each load of sod shall be accompanied by a certificate from the grower stating

the type of sod and the date and time of cutting.

CONSTRUCTION REQUIREMENTS

212.03 Seeding Seasons. Seeding in areas that are not irrigated shall be restricted according to the following time table and specifications.

Zone	Spring Seeding	Fall Seeding
Areas other than the Western Slope		
Below 6000'	Spring thaw to June 1	September 15 until consistent ground freeze
6000' to 7000'	Spring thaw to June 1	September 1 until consistent ground freeze
7000' to 8000'	Spring thaw to July 15	August 1 until consistent ground freeze
Above 8000'	Spring thaw to consistent ground freeze	
Western Slope		
Below 6000'	Spring thaw to May 1	August 1 until consistent ground freeze
6000' to 7000'	Spring thaw to June 1	September 1 until consistent ground freeze
Above 7000'	Spring thaw to consistent ground freeze	

- (1) "Spring thaw" shall be defined as the earliest date in a new calendar year in which seed can be buried ½ inch into the surface soil (topsoil) thru normal drill seeding methods.
- (2) "Consistent ground freeze" shall be defined as that time during the fall months in which the surface soil (topsoil), due to freeze conditions, prevents burying the seed ½ inch thru normal drill seeding operations. Seed shall not be sown, drilled, or planted when the surface soil or topsoil is in a frozen or crusted state.

Seeding accomplished outside the time periods listed above will be allowed only when ordered by the Engineer or when the Contractor's request is approved in writing. When requested by the Contractor, the Contractor must agree to perform the following work at no cost to the Department: reseed, remulch, and repair areas which fail to produce species indicated in the Contract.

When seeding is ordered by the Engineer outside the time periods listed above, the cost of additional material will be paid for by the Department. The Contractor will not be responsible for failure of the seeded area to produce species indicated in the Contract due to reasons beyond the control of the Contractor.

The seeding, the soil conditioning, and the fertilizing application rate shall be as specified. The Engineer may establish test sections for adjusting the seeding and

the fertilizing equipment to assure the specified rate. The Engineer may order equipment readjustment at any time.

Seed, soil conditioner and fertilizer shall not be applied during inclement weather including rain and high winds, or when soil is frozen or soil moisture is too high to evenly incorporate seed, soil conditioner or fertilizer.

212.04 Lawn Grass Seeding. Lawn grass seeding shall be accomplished in the seeding seasons described in subsection 212.03.

- (a) *Soil Preparation.* Preparatory to seeding lawn grass, irregularities in the ground surface, except the saucers for trees and shrubs, shall be removed. Measures shall be taken to prevent the formation of low places and pockets where water will stand.

Immediately prior to seeding, the ground surface shall be tilled or hand worked into an even and loose seedbed to a depth of 4 inches, free of clods, sticks, stones, debris, concrete, and asphalt in excess of 2 inches in any dimension, and brought to the desired line and grade.

- (b) *Fertilizing and Soil Conditioning.* The first application of fertilizer, soil conditioner, or both shall be incorporated into the soil prior to seeding, and shall consist of a soil conditioner, commercial fertilizer, or both as designated in the Contract. Fertilizer called for on the plans shall be worked into the top 4 inches of soil at the rate specified in the contract. Biological nutrient, culture or humic acid based material called for on the plans shall be applied in a uniform application onto the soil surface. Organic amendments shall be applied uniformly over the soil surface and incorporated into the top 6 inches of soil.

The second application of fertilizer shall consist of a fertilizer having an available nutrient analysis of 20-10-5 applied at the rate of 100 lbs. per acre. It shall be uniformly broadcast over the seeded area three weeks after germination or emergence. The area shall then be thoroughly soaked with water to a depth of 1 inch.

Fertilizer shall not be applied when the application will damage the new lawn.

- (c) *Seeding.* After the surface is raked and rolled, the seed shall be drilled or broadcast and raked into the top $\frac{1}{4}$ inch of soil. Seeding shall be accomplished by mechanical landscape type drills. Broadcast type seeders or hydraulic seeding will be permitted only on small areas not accessible to drills. Seed shall not be drilled or broadcast during windy weather or when the ground is frozen or untillable. All loose exposed rock larger than 2 inches shall be removed from slopes that are to be seeded by drilling.

Hydraulic seeding equipment shall include a pump capable of being operated at 100 gallons per minute and at 100 pounds per square inch pressure, unless otherwise directed. The equipment shall have a nozzle adaptable to hydraulic

seeding requirements. Storage tanks shall have a means of estimating the volume used or remaining in the tank.

212.05 Sodding.

- (a) *Soil Preparation.* Preparatory to sodding, the ground shall be tilled or hand worked into an even and loose sod bed to a depth of 4 inches, and irregularities in the ground surface shall be removed. Sticks, stones, debris, clods, asphalt, concrete, and other material more than 2 inches in any dimension shall be removed. Any depressions or variances from a smooth grade shall be corrected. Areas to be sodded shall be smooth before any sodding is done.
- (b) *Sodding.* The sod shall be laid by staggering joints with all edges touching. On slopes, the sod shall run approximately parallel to the slope contours. Where the sod abuts a drop inlet, the subgrade shall be adjusted so that the sod shall be 1½ inch below the top of the inlet.

Within one hour after the sod is laid and fertilized it shall be watered. After watering the sod shall be permitted to dry to the point where it is still wet enough for effective rolling. It shall then be rolled in two directions with a lawn roller weighing at least 150 pounds.

- (c) *Fertilizing and Soil Conditioning.* Prior to laying sod, the 4 inches of subsoil underlying the sod shall be treated by tilling in fertilizer, soil conditioner, or both. The rate of application shall be as designated in the Contract. Fertilizer called for on the plans shall be worked into the top 4 inches of soil at the rate specified in the contract. Biological nutrient, culture or humic acid based material called for on the plans shall be applied uniformly onto the soil surface. Organic amendments shall be applied uniformly over the soil surface and incorporated into the top 6 inches of soil.

After laying, the sod shall be fertilized with a fertilizer having an available nutrient analysis of 20-10-5 at the rate of 200 pounds per acre. Fertilizer shall not be applied when the application will damage the sod.

212.06 Native Seeding. Areas that are unirrigated shall be seeded in accordance with subsection 212.03.

- (a) *Soil Preparation.* Slopes flatter than 2:1, shall be tilled into an even and loose seed bed 4 inches deep. Slopes 2:1 or steeper shall be left in a roughened condition. Slopes shall be free of clods, sticks, stones, debris, concrete, and asphalt in excess of 4 inches in any dimension, and brought to the desired line and grade.
- (b) *Fertilizing and Soil Conditioning.* Prior to seeding, fertilizer, soil conditioner, or both shall be applied. The fertilizer and soil conditioner type and rate of application shall be as designated in the Contract. Fertilizer called for on the plans shall be worked into the top 4 inches of soil at the rate specified in the

contract. Biological nutrient, culture or humic acid based material called for on the plans shall be applied in a uniform application onto the soil service. Organic amendments shall be applied uniformly over the soil surface and incorporated into the top 6 inches of soil. No measurable quantity of organic amendment shall be present on the surface after incorporation.

- (c) *Seeding.* Seeding shall be accomplished within 24 hours of tilling or scarifying to make special seed bed preparation unnecessary. The seeding application rate shall be as designated in the Contract. All slopes flatter than 2:1 shall be seeded by mechanical power drawn drills followed by packer wheels or drag chains. Mechanical power drawn drills shall have depth bands set to maintain a planting depth of at least $\frac{1}{4}$ inch and shall be set to space the rows not more than 7 inches apart. Seed that is extremely small shall be sowed from a separate hopper adjusted to the proper rate of application.

If strips greater than 7 inches between the rows have been left unplanted or other areas skipped, the Engineer will require additional seeding at the Contractor's expense.

When requested by the Contractor and approved by the Engineer, seeding may be accomplished by broadcast or hydraulic type seeders at twice the rate specified in the Contract at no additional cost to the project.

All seed sown by broadcast-type seeders shall be "raked in" or covered with soil to a depth of at least $\frac{1}{4}$ inch. Broadcasting seed will be permitted only on small areas not accessible to machine methods.

Hydraulic seeding equipment and accessories shall conform to the equipment and accessories described in subsection 212.04(c).

Seeded areas damaged due to circumstances beyond the Contractor's control shall be repaired and reseeded as ordered. Payment for this corrective work, when ordered, shall be at the contract prices.

Multiple seeding operations shall be anticipated as portions of job are completed to take advantage of growing conditions and to comply with Section 208 and subsection 212.03.

METHOD OF MEASUREMENT

212.07 The quantities of lawn seeding and native seeding will not be measured but shall be the quantities designated in the Contract, except that measurements will be made for revisions requested by the Engineer, or for discrepancies of plus or minus five percent of the total quantity designated in the Contract. The quantity of lawn seeding shall include soil preparation, water, fertilizer, and seed, completed and accepted. The quantity of native seeding shall include soil preparation, fertilizer, soil conditioner, and seed applied, completed, and accepted.

The quantity of sod to be measured will be the actual number of square feet,

including soil preparation, water, fertilizer, and sod, completed and accepted.

When soil conditioner is measured and paid for separately, it will be measured by the actual number of acres to which soil conditioner is applied and will be paid for as Soil Conditioning.

The Contractor shall furnish the Engineer with seed certifications and analysis, fertilizer analysis, and bag weight tickets prior to placing any seed or fertilizer. Any seed or fertilizer placed by the Contractor without the Engineer's approval will not be paid for.

Measurement for acres will be by slope distances.

BASIS OF PAYMENT

212.08 The accepted quantities of lawn seeding, native seeding, soil conditioning, and sod will be paid for at the contract unit price for each of the pay items listed below that appear in the bid schedule.

Payment will be made under:

Pay Item	Pay Unit
Seeding (Lawn)	Acre
Seeding (Native)	Acre
Sod	Square Foot
Soil Conditioning	Acre

Soil preparation, water, seed, fertilizer, and soil conditioner, incorporated into the seeding sodding or soil conditioning will not be paid for separately but shall be included in the work.

Adjusting or readjusting seeding or fertilizing equipment will not be paid for separately but shall be included in the work.

SECTION 213 MULCHING

DESCRIPTION

213.01 This work consists of mulching the seeded areas, furnishing and placing wood chip mulch in the planting beds and plant saucers, furnishing and applying hydromulch with tackifier on roadway ditches and slopes, furnishing and placing tackifier on mulch or soil on roadway ditches or slopes, and furnishing and installing metal landscape border for the separation of planting beds, in accordance with the Contract or as directed. Mulching may be accomplished by the crimping method using straw or hay, by the hydraulic method using wood cellulose fiber mulch, or by other approved methods with approved materials. When a specific mulching method is required, it will be designated in the Contract.

This work includes furnishing and applying spray-on mulch blanket or bonded fiber matrix on top of rock cuts and slopes after seeding or as temporary stabilization as shown on the plans or as directed by the Engineer.

MATERIALS

213.02 Materials shall conform to the following requirements.

(a) *Mulching*. Materials for mulching shall consist of Certified Weed Free field or marsh hay or straw of oats, barley, wheat, rye or triticale certified under the Colorado Department of Agriculture Weed Free Forage Certification Program and inspected as regulated by the Weed Free Forage Act, Title 35, Article 27.5, CRS. Each certified weed free mulch bale shall be identified by one of the following:

- (1) One of the ties binding the bale shall consist of blue and orange twine, or
- (2) The bale shall have a regional Forage Certification Program tag indicating the Regional Forage Certification Program Number.

Mulch shall be inspected for and Regionally Certified as weed free based on the Regionally Designated Noxious Weed and Undesirable Plant List for Colorado, Wyoming, Montana, Nebraska, Utah, Idaho, Kansas and South Dakota.

The Contractor shall not unload certified weed free mulch bales or remove their identifying twine, wire, or tags until the Engineer has inspected and accepted them.

The Contractor shall provide a transit certificate that has been filled out and signed by the grower and by the Department of Agriculture inspector.

The Contractor may obtain a current list of Colorado Weed Free Forage Crop Producers who have completed certification by contacting the Colorado Department of Agriculture, Division of Plant Industry.

Straw or hay in a stage of decomposition (discolored, brittle, rotten, or moldy) or old, dry mulch which breaks in the crimping process will not be accepted.

The type and application rate of mulch material shall be as designated in the Contract.

- (b) *Wood Cellulose Fiber Mulch.* Wood cellulose fiber mulch shall consist of virgin wood fibers manufactured expressly from clean whole wood chips. The chips shall be processed in such a manner as to contain no growth or germination inhibiting factors. Fiber shall not be produced from recycled materials such as sawdust, paper, cardboard, or residue from pulp and paper plants. The wood cellulose fibers of the mulch must maintain uniform suspension in water under agitation. Upon application, the mulch material shall form a blotter like mat covering the ground. This mat shall have the characteristics of moisture absorption and percolation and shall cover and hold seed in contact with the soil. The Contractor shall obtain certifications from suppliers that laboratory and field testing of their product has been accomplished, and that it meets all of the foregoing requirements pertaining to wood cellulose fiber mulch.

The wood cellulose fiber mulch shall conform to the following specifications:

Property	Requirement
Percent moisture content	10.0% ± 3.0%
Percent Organic Matter* (Wood Cellulose Fiber)	99.3% ± 0.2%
Percent Ash Content*	0.7% ± 0.2%
pH	4.9 ± 0.5
Water Holding Capacity*	1200-1600 grams**
*Oven Dried Basis **Per 100 grams of fiber	

The wood cellulose fiber mulch shall be packaged in units containing current labels, with the manufacturer's name, the net weight, and certification that the material meets the foregoing requirements for wood cellulose fiber mulch.

- (c) *Mulch Tackifier.* Material for mulch tackifier shall consist of a free-flowing, noncorrosive powder produced either from the natural plant gum of *Plantago Insularis* (Desert Indianwheat) or pre-gelatinized 100 percent natural corn starch polymer. The powders shall possess the following properties:

Plantago Insularis (Desert Indianwheat):

Property	Requirement	Test Method
pH 1% solution	6.5 - 8.0	
Mucilage content	75% min.	ASTM D7047

Pre-gelatinized 100 percent natural corn starch polymer:

Property	Requirement
Organic Nitrogen as protein	5.5-7%
Ash content	0-2%
Fiber	4-5%
pH 1% solution	6.5 – 8.0
Size	100% thru 850 microns (20 mesh)
Settleable solids	<2%

All fibers shall be colored green or yellow with a biodegradable dye.

The material used for mulch tackifier shall not contain any mineral filler, recycled cellulose fiber, clays, or other substances which may inhibit germination or growth of plants. Water shall conform to subsection 209.02.

- (d) *Wood Chip Mulch.* Wood chip mulch shall consist of fresh, moist pole peelings material having approximate dimensions;

Width: ¼ to ½ inch; Length: 3 to 4 inches

The Contractor shall submit a sample to the Engineer for approval at least 30 days prior to placing on the project.

- (e) *Metal Landscape Border.* The metal landscape border shall consist of a strip of metal such as steel conforming to ASTM A1011 or approved equal.

- (f) *Spray-on Mulch Blanket.* Spray on mulch blanket shall be one of the following, unless otherwise shown on the plans:

- (1) Spray-on Mulch Blanket (Type 1) shall be a hydraulically applied matrix containing organic fibers, water soluble cross-linked tackifier, and reinforcing interlocking fibers. The reinforcing interlocking fibers may be natural or synthetic or a combination thereof. Mulch Blanket (Type 1) shall conform to the following:

Properties	Requirement	Test Method
Organic Fibers	71% Min.	ASTM D2974
Cross linked Tackifiers	10% ± 2% Min.	
Reinforcing Interlocking Fibers	10% ± 1% Min.	
Biodegradability	100%	ASTM D5338
Ground Cover at Application Rate	90% Min.	ASTM D6567
Functional Longevity	12 Months Min.	
Cure Time	< 8 hours	
Application		
Application Rate	3,000 lb./acre	

The organic fiber shall not contain lead paint, printing ink, varnish, petroleum products, seed germination inhibitors, or chlorine bleach. The organic fibers and reinforcing interlocking fibers cannot be produced from sawdust, cardboard, paper, or paper by-products.

- (2) Spray-on Mulch Blanket (Type 2) shall be a hydraulically applied matrix pre-packaged in 50 pound bags containing both a soil and fiber stabilizing compound and thermally processed wood fiber.

The sterilized weed-free wood fiber mulch shall be manufactured through a thermo-mechanical defibrating process containing a specific range of fiber lengths averaging 0.25 inches or longer.

Mulch Blanket (Type 2) shall meet the following requirements:

Property	Requirement	Test Method
Fiber Retention On 28-Mesh Screen	≥ 40%	Tyler Ro-Tap Method
Moisture Content	12% ± 2%	Total Air Dry Weight Basis
Organic Matter	99.2% ± 0.2%	Oven Dry Weight Basis
Ash Content	0.8% ± 0.2%	Oven Dry Weight Basis
pH At 3% Consistency In Water	4.5-7.0 ± 0.5%	
Sterilized Weed-Free	Yes	
Non-Toxic To Plant Or Animal Life	Yes	
Application		
Application rate	3,000 lb./acre	

The soil and fiber stabilizing compound shall be composed of linear anionic copolymers of acrylamide pre-packed within the bag having a minimum content of 1.0 percent. The compound shall conform to the following:

Property	Requirement
Molecular Weight	≥ 12x10 ⁶
Charge Density	> 25%
Non-Toxic To Plant Or Animal Life	Yes

- (g) *Bonded Fiber Matrices (BFM)*. BFM shall consist of hydraulically-applied matrix with a minimum of 70 percent non-toxic thermally processed or refined long strand organic fibers and water soluble tackifier to provide erosion control and shall be designed to be functional for a minimum of 9 months. BFMs form an erosion-resistant blanket that promotes vegetation and

prevents soil erosion. The BFM shall be 100 percent biodegradable. The binder in the BFM shall also be biodegradable. BFMs shall conform to the following requirements:

Property	Requirement	Test Method
Ground Cover (%)	95	ASTM D6567
Bio-degradability (%)	100	ASTM D5338
Functional Longevity (months)	9 month minimum	
Cure Time (hours)	24-48	
Cross-linked Tackifier	10% minimum	
Application		
Application Rate (lbs./Acre)	3000	

The fibers shall not contain lead paint, printing ink, varnish, petroleum products, seed germination inhibitors, or chlorine bleach. Fiber shall not be produced from sawdust, cardboard, paper, or paper by-products.

CONSTRUCTION REQUIREMENTS

213.03

- (a) *Hay or Straw Mulching.* After seeding has been completed or when required for erosion control, hay or straw shall be uniformly applied, with no bare soil showing, at the rate designated in the Contract or as directed. It shall be crimped in with a crimper or other approved equipment. The Engineer may order hand-crimping on areas where mechanical methods cannot be used.

The seeded area shall be mulched and crimped within four hours after seeding. Areas not mulched and crimped within four hours after seeding or prior to precipitation or damaging winds on site shall be reseeded with the specified seed mix at the Contractor's expense, prior to mulching and crimping.

When tackifier is required in the Contract it shall be applied in the following order: (1) mulching, (2) mulch tackifier.

- (b) *Hydraulic Mulching.* Wood cellulose fiber mulch and mulch tackifier shall be added to water to form a homogeneous slurry. The operator shall spray apply the slurry mixture uniformly over the designated seeded area.

Hydraulic mulching shall not be done in the presence of free surface water.

Mixing procedure for the hydraulic mulch and tackifier mixture shall be as follows:

- (1) Fill tank with water approximately $\frac{1}{4}$ full.
- (2) Continue filling while agitating with engine at full rpm.
- (3) Pour tackifier, at a moderate rate, directly into area of greatest turbulence.
- (4) With the recommended amount of tackifier in solution, add wood cellulose fiber mulch. Do not add fertilizer.

Apply the hydromulch and tackifier mixture at the following rate:

Wood Cellulose Fiber Mulch	Tackifier
2000 lbs./Acre	100 lbs./Acre

(c) *Mulch Tackifier.*

Mixing procedure for mulch tackifier shall be as follows:

- (1) Fill tank with desired amount of water and run engine at full R.P.M.
- (2) Add wood cellulose fiber. Agitate until a homogenous, non-lumpy slurry is formed. Do not add fertilizer
- (3) Slowly sift powdered tackifier into slurry and continue to agitate for at least five minutes.

Mulch tackifier shall be sprayed over hay or straw using a nozzle that will disperse the spray into a mist that will uniformly cover the mulch.

Application Rate: Apply this as an overspray at the following rate or as approved by the Engineer.

Powder	Wood Cellulose Fiber	Water
200 lbs./Acre	300 lbs./Acre	2000 gal./Acre

- (d) *General.* Mulch shall be tacked simultaneously or immediately upon completion of mulching and crimping to avoid non-uniform coverage. Areas not properly mulched, or areas damaged due to the Contractor's negligence, shall be repaired and remulched as described above, at the Contractor's expense.

Mulch removed by circumstances beyond the Contractor's control shall be repaired and remulched as ordered. Payment for this ordered corrective work shall be at the contract prices.

The Engineer may order test sections be established for adjusting the mulching equipment to assure conformance with the specified application rate. The Engineer may order equipment readjustment at any time.

- (e) *Wood Chip Mulch.* A 4-inch layer, unless otherwise shown in the plans, of

wood chip mulch shall be uniformly applied to all planting beds as shown on the plans or as directed. Wood chip mulch shall be placed in all tree and shrub saucers in seeded areas. Wood chip mulch shall be capable of matting together to resist scattering by the wind.

- (f) *Metal Landscape Border.* Metal landscape border shall be installed along the lines and at the grades shown on the plans by an approved method that will not damage the border. Ends of metal landscape border shall overlap the next adjacent section a minimum of 6 inches. Metal landscape border shall be anchored with wire tie-downs at intervals of approximately 2 feet. Wire tie-downs shall be 9 gage wire at least 14 inches long. Metal landscape border shall be inserted into the ground by driving against the wire tiedowns; ground may be moistened to ease entrance into the ground. Driving on edge of metal landscape border will not be permitted except when the edge is properly shielded. Metal landscape border may be bent for sharp angles, and overlapped at closure of perimeter.
- (g) *Spray-On Mulch Blanket.* Spray-on mulch blanket installation shall strictly comply with the Manufacturer's mixing recommendations and installation instructions. No chemical additives with the exception of fertilizer, soil pH modifiers, extended-term dyes and bio nutrients will be permitted. The spray-on mulch blanket shall be mixed and applied as follows:

The hydromulching vessel shall be filled with water to at least $\frac{1}{3}$ capacity (high enough to cover agitators) prior to adding any material. Continue to fill vessel with water and slowly add the fibers while agitators are in motion. Run agitators at $\frac{3}{4}$ speed. Continue to mix tank a minimum of 10 minutes prior to application.

Apply spray-on mulch blanket in a uniform application using a minimum 22 degree arc type nozzle. Apply hydro slurry in two direction (from top of slope down and from toe of the slope up, as well as, be applied at a minimum of two layers).

Co-polymer shall not be used use in channels, swales, or other areas where concentrated flows are anticipated and should not be used on saturated soils that have groundwater seeps.

- (h) *Bonded Fiber Matrices (BFM).* Bonded fiber matrices shall strictly comply with the Manufacturer's mixing recommendations and installation instructions. No chemical additives with the exception of fertilizer, soil pH modifiers, extended-term dyes, and bio stimulant materials shall be permitted. BFMs shall be applied in a uniform application using a minimum 22 degree arc type nozzle. BFMs shall be applied in two directions (from top of slope down and from toe of the slope up, as well as, be applied at a minimum of two layers).

Biodegradable BFMs shall not be applied immediately before, during, or immediately after rainfall if the soil is saturated.

BFGs shall not be used in channels, swales, or other areas where concentrated flows are anticipated and shall not be used on saturated soils that have groundwater seeps.

Foot traffic, mechanical traffic or grazing shall not be permitted on treated areas until vegetated. Treated areas damaged due to circumstances beyond the Contractor's control shall be repaired or re-applied as ordered. Payment for corrective work, when ordered, shall be at contract unit prices.

METHOD OF MEASUREMENT

213.04 The quantity of hay and straw mulch, wood chip mulch, wood fiber and, spray-on mulch blanket, bonded fiber matrix, and tackifier will not be measured but shall be the quantity designated in the Contract, except that measurements will be made for revisions requested by the Engineer, or for discrepancies of plus or minus five percent of the total quantity designated in the Contract. Measurement for acres will be by slope distances.

The quantity of mulch tackifier to be measured will be the actual number of pounds of dry tackifier powder used.

Metal landscape border will be measured by the linear foot of completed and accepted metal border. Measured length of metal landscape border will not include required overlap splices.

Spray-on mulch blanket and bonded fiber matrix will be measured by the acre or by the actual pounds of product applied, as shown on the plans. The area will be calculated on the basis of actual or computed slope measurements. The Contractor shall verify, prior to application, weight of spray on mulch blanket and bonded fiber matrix bags for certification of materials and application rate.

BASIS OF PAYMENT

213.05 The accepted quantities will be paid for at the contract unit price for each of the pay items listed below that appear in the bid schedule.

Payment will be made under:

Pay Item	Pay Unit
Mulching ()	Acre
Mulching (Hydraulic)	Acre
Mulching (Weed Free Hay)	Acre
Mulching (Weed Free Straw)	Acre
Mulching (Wood Chip)	Cubic Foot
Mulch Tackifier	Pound
Metal Landscape Border Inch	Linear Foot
Spray-on Mulch Blanket	Acre

Spray-on Mulch Blanket	Pound
Bonded Fiber Matrix	Acre
Bonded fiber Matrix	Pound

Water, wood fiber, mixing and application for mulch tackifier will not be measured and paid for separately but shall be included in the work.

Adjusting or readjusting mulching equipment will not be paid for separately but shall be included in the work.

Payment for spray-on mulch blanket and bonded fiber matrix will be full compensation for all work and materials necessary to complete the item.

SECTION 214 PLANTING

DESCRIPTION

214.01 This work consists of furnishing and planting trees, shrubs, wetland perennials, and other plant material, hereinafter referred to as “plants” and obtaining live brush layer cuttings from onsite willow species designated by the Engineer near the project site and planting them in moist areas as shown on the plans or as directed.

MATERIALS

214.02 General. Plants shall be of the species or variety designated in the Contract, in healthy condition with normal well developed branch and root systems, and shall conform to the requirements of the current American Standard for Nursery Stock. The Contractor shall obtain certificates of inspection of plant materials that are required by Federal, State, or local laws, and submit the certificates to the Engineer.

All plants shall be free from plant diseases and insect pests. All shipments of plants shall comply with all nursery inspection and plant quarantine regulations of the State of origin and destination, and the Federal regulations governing Interstate movement of nursery stock.

The minimum acceptable sizes of all plants, with branches in normal position, shall conform to the measurements specified in the Contract.

Plants hardy in hardiness zones 2, 3, 4, and 5 only will be accepted. Hardiness zones are defined in U.S. Department of Agriculture publications.

All container grown plants shall be those plants that have been growing in a nursery for at least one growing season, or plants that have established themselves in accordance with definitions set forth in the Colorado Nursery Act, Title 35, Article 26, CRS.

Trees and shrubs shall have been root-pruned during their growing period in the nursery in accordance with standard nursery practice.

If plants of acceptable quality and specified variety or size are not available locally, the Contractor may:

- (1) Substitute acceptable plants that are larger than specified at no change in contract price.
- (2) On written approval, substitute smaller plants than those specified in the Contract at the adjusted price stated in the written approval.
- (3) On written approval, substitute plants of a different genus, species, or variety at the adjusted price stated in the written approval.

Before any substitution of plants will be considered, the Contractor shall furnish to the Engineer written statements from three sources verifying that the plants designated on the plans are not available.

At the landscape Pre-construction Conference, the Contractor shall name the nursery stock supplier for all items. The Contractor shall tag all nursery stock for inspection by the Engineer. The Engineer will reject any nursery stock not meeting the Contract at any of the three following times and locations:

- (1) At the named supplier's location. The Engineer will notify the Contractor when nursery stock will be inspected at the supplier's location.
- (2) On the project site at the time of delivery, prior to planting.
- (3) At the time of installation. Final acceptance of all plant material will be made at the time of installation on the project site.

Deciduous plants, broadleaf evergreens, and conifers shall be balled and burlapped, or in containers used in standard nursery practice. Balling and burlapping shall conform to the recommended specifications in the American Standard for Nursery Stock. The ball of the plant shall be natural, not made, and the plant shall be handled by the ball at all times. No balled and burlapped plant shall be accepted if the ball is broken or the trunk is loose in the ball.

Each species shall be identified by means of grower's label affixed to the plant. The grower's label shall include the data necessary to indicate conformance to specifications.

Plants for fall planting shall be furnished balled and burlapped or container-grown unless otherwise designated in the Contract or approved.

- (a) *Brush Layer Cuttings*. Brush layer cuttings taken from designated plants shall be at least 0.5 inch in diameter or larger. Brush layer cuttings shall be 24 to 36 inches long with the bottom end cut off at an angle and the top end with a straight cut. Cuttings shall be taken and installed while dormant in early spring. Cuttings shall not be planted when the ground is frozen. Brush layer cuttings shall be stored no longer than one week. The cuttings shall be stored by submerging them at least $\frac{2}{3}$ of their length in containers of water, free from any harmful oil, chemical, sprays, or other materials. The containers shall be kept in the shade.
- (b) *Wetland Perennial Plants*. Perennial wetland plants shall be supplied in containers as designated in the Contract; no bare root material will be allowed. The original plant stock for the plants shall be from Colorado. Perennial plants shall have been growing at least one growing season in the nursery. Perennial shall not be shipped while in a dormant condition. Perennials shall be a minimum of 6 inches in height when applicable to the species. Water shall be applied to wetland perennial plants until soil is saturated. Wetland perennial plants shall be watered thoroughly every day for a period of one month.

- (c) *Stakes.* Wood stakes shall be 2 inches x 2 inches square, or 2 ½ inch diameter and 6 feet long free from bends. Metal stakes shall be 6 feet long standard T-bar steel fence post or #4 or larger rebar. Wood stakes shall be made of untreated wood guaranteed to last in the ground at least two growing seasons. The bottom of wood stakes shall be pointed.
- (d) *Soil Conditioners and Fertilizer.* Soil conditioner shall consist of composted plant material, 90 percent ¼ inch or less with a carbon to nitrogen ratio of 15:1 to 25:1. A sample of the soil conditioner and certificate of compliance shall be provided to the Engineer to verify the organic matter content, and carbon matter to nitrogen ratio shall be submitted one month prior to planting for approval.

Fertilizer for planting shall be used as specified in the Contract.

CONSTRUCTION REQUIREMENTS

214.03 General. All plants shall be protected from drying out or other injury. Broken and damaged roots shall be pruned before planting.

- (a) *Planting Seasons.* Plants shall be planted in accordance with the Contract.

Areas to be planted shall be brought to the lines and grades designated or approved. The location of plants shown in the Contract is approximate to the degree that unsuitable planting locations shall be avoided. Trees shall be planted at least 30 feet from the edge of the traveled way, except when guardrail or vertical curb exists, this distance may be reduced to 20 feet. Locations and layouts shall be approved before preparatory work for planting is started. Shrubs shall not be planted closer than 6 feet from the edge of pavement.

All layout staking for planting shall be done by the Contractor and shall be approved by the Engineer before planting holes are prepared.

The Contractor shall place all plant material according to the approved planting plans, or as directed.

- (b) *Excavation.* Planting pits shall be circular in outline with vertical or sloped sides. Pits for trees and shrubs shall be at least two times greater in diameter than the earth ball.
- (c) *Planting.* Planting shall be done in accordance with good horticultural practices. Plants of upright growth shall be set plumb and plants of prostrate type shall be set normal to the ground surface. Plants with dry, broken, or crumbling roots will not be accepted for planting.

Planting pits shall be dug 2 to 4 inches shallower than the height of the rootball for trees, and 2 inches shallower for shrubs. In non-irrigated areas, planting pits shall be dug so that the top of the rootball is level with the final grade. The tree rootball shall be set in the center of the planting pit on undisturbed soil. Trees shall be stabilized and then the wire basket, any twine

or wire, and burlap shall be removed before the pit is backfilled. Shrubs shall be planted in the center of the pit. Plastic, metal, fabric, or peat containers shall be removed. Shallow scores $\frac{1}{4}$ to $\frac{1}{2}$ inch deep shall be made along the edges of the rootball.

Areas to be planted with ground cover shall be prepared by placing topsoil and a $\frac{1}{2}$ inch layer of soil conditioner on the ground surface, and roto-tilling to a depth of 6 inches. Ground cover shall be planted by excavating to a depth sufficient to accommodate the root structure of plant materials without crimping or bending roots. After planting, backfill shall be placed around the ground cover and compacted firmly around the roots. The planted areas shall be brought to a smooth and uniform grade, and then top dressed with a 2 inch mulch cover of the type specified on the plans.

- (d) *Backfilling.* When soil conditioner is specified, composted plant material shall be added and thoroughly mixed into the backfill material at the rate of 0.5 cubic foot per tree and 0.1 cubic foot per shrub.

Backfill shall be thoroughly worked and watered-in to eliminate air pockets. Watering shall be done immediately after the plant is placed. Backfilling of the planting pit shall be resumed after this water is absorbed. Roots and crown shall be covered with soil at this time. After the soil has settled, plants must be in the proper position and at the proper depth. Saucers shall be prepared around each plant to the dimensions shown on the planting details. When saucers are required they shall be covered with a 4 inch thick layer of fresh moist wood chip mulch conforming to Section 213. After completion of all planting and before acceptance of the work, the Contractor shall water plants installed under this Contract, as needed to maintain a moist root zone optimum for plant growth. Plants damaged by the Contractor's operations shall be replaced at the Contractor's expense.

Surplus soil remaining after backfilling is completed shall be used for constructing water retention berms, or, if not needed for berms, shall be thinly distributed (wasted) in the vicinity, subject to approval of the Engineer.

- (e) *Pruning.* All deciduous trees and shrubs shall be pruned in accordance with standard horticultural practice, preserving the natural character of the plant. Guidelines for pruning are indicated in the planting details. Pruning cuts shall be made with sharp clean tools.

All clippings shall become the property of the Contractor and be removed from the site.

- (f) *Staking.* All deciduous trees 2 inch caliper and greater shall be staked with two stakes. Stakes shall conform to subsection 214.02(c). Stakes shall be driven 2 feet into the ground with one stake on the side of the prevailing wind (generally the west side) and the other stake on the opposite side. Stakes shall be driven at least 1 foot outside each edge of the planting pit. Trees shall be guyed with 1 to 2 inch wide strips of nylon webbing with metal grommets.

Coniferous trees 4 feet or taller shall be staked as designated in the Contract or as directed.

Stakes shall be spaced equally around the tree.

Trees specified to be guyed with wire shall be secured with No. 12 gage annealed galvanized steel wire free of bends and kinks.

- (g) *Wrapping Materials.* Wrapping material shall be horticulturally approved waterproof wrapping paper. Wrapping shall be applied from the base of the tree upward to the second scaffold branch and secured with arbor tape. Populus sp. are exempt from tree wrap. The Contractor shall submit the manufacturer's certification for the wrapping material requirements. Wrapping shall be done in the fall months prior to freeze, and removed in the spring. Wrapping shall not remain on any trees throughout the summer months. Wrapping shall be removed by the Contractor.

All plant tags shall be removed from plants and all packing or other material used by the Contractor shall be removed from the site.

- (h) *Brush Layer Cuttings.* Using a rock bar or other tool, holes at least 20 inches deep shall be made in the stream bank or other areas. A cutting shall be placed in each hole. If in riprap, the hole shall be backfilled with soil to within 3 inches of the riprap surface. The top 3 inches of the void shall be filled with gravel from the stream bank or streambed and compacted slightly. The remaining exposed length shall be cut off 2 to 3 inches above the ground line. The placement of these cuttings shall be in areas shown on the plans that remain damp or are seasonally inundated, as directed. Brush layer cuttings shall be planted at a density of one cutting per square yard on streambank or other designated areas that have been regraded, riprapped, or disturbed. The strip that is most successful for brush layer cutting establishment is only several yards wide and approximately, plus or minus, 2 feet from the ordinary high water line.

Water shall be applied to the brush layer cuttings planted areas until the soil mass is saturated. Brush layer cuttings shall be watered thoroughly every day for a period of one month.

- (i) *Irrigation.* Plantings that are to be irrigated shall be planted so that the irrigation system is operating and supplying the designated amount of water as planting is occurring. Plants shall be watered within 15 minutes of planting.

214.04 Landscape Establishment. From the time of installation, during construction, and throughout the Landscape Establishment period the Contractor shall maintain all plant material and seeded areas in a healthy and vigorous growing condition, and ensure the successful establishment of vegetation. This includes performing establishment, replacement work, and landscape maintenance work as described below.

The beginning of the Landscape Establishment period depends upon receipt of the written Notice of Substantial Landscape Completion from the Engineer. Substantial Landscape Completion occurs when all plant materials in the Contract have been planted and all work under Sections 212, 213, 214 and 623 has been performed, except for the Section 214 pay item, Landscape Maintenance. If the Notice of Substantial Landscape Completion is issued during the spring planting season, the Landscape Establishment period begins immediately and lasts for a period of 12 months. If the Notice of Substantial Landscape Completion is issued at any other time, the Landscape Establishment period begins at the start of the next spring planting season and lasts for a period of 12 months.

- (a) *Establishment and Replacement.* After all planting on the project is complete, a plant inspection shall be held including the Contractor, Engineer and CDOT Landscape Architect to determine acceptability of plant material. During the inspection, an inventory of rejected material will be made, and corrective and necessary cleanup measures will be determined.

Dead, dying, or rejected material shall be removed each month during the Landscape Establishment period as directed. Plant replacement shall be performed during the spring planting seasons at the beginning and end of the Landscape Establishment Period. Plant replacement stock shall be planted in accordance with the Contract and is subject to all requirements specified for the original material. Plant replacement shall be at the Contractor's expense.

- (b) *Landscape Maintenance.* During the Landscape Establishment period the Contractor shall perform landscape maintenance as described herein. The Contractor shall maintain all landscaped areas in the condition they were in when first installed and accepted.

Prior to the Notice of Substantial Landscape Completion, the Contractor shall submit a detailed maintenance plan which includes a schedule showing the number of hours or days personnel will be present, the type of work to be performed, supervision, equipment and supplies to be used, emergency program and responsible person to contact for emergency work, and inspection schedule. The detailed maintenance plan is subject to review and approval by the Engineer. The Engineer will not issue the Notice of Substantial Completion until the Engineer has received and approved the maintenance plan.

The proposed types, brand names, material safety data sheets, and rates of application of herbicides, pesticides, and fertilizers to be used shall be submitted for approval with the detailed maintenance plan. Herbicides, pesticides, and fertilizers shall meet all local, state, and federal regulations and shall be applied by a licensed applicator.

The Contractor shall perform start-up, watering, programming, operation, and fall winterization of the irrigation system. The Contractor shall do a spring start-up of the irrigation system prior to Final Acceptance and perform all irrigation system warranty work as specified in Section 623.

The Contractor shall keep a project diary documenting all landscape and irrigation maintenance activities including work locations and time spent. The Contractor shall provide copies of the diary to the Engineer upon request.

The Contractor shall restore and reseed eroded areas and areas of poor establishment in accordance with Sections 212 and 213. The Contractor shall maintain staking and guying until the end of the Landscape Establishment period. The Contractor shall remove all guying wire, straps, and stakes at the end of the Landscape Establishment period.

During the landscape establishment period, the Contractor shall water, cultivate, and prune the plants and repair, replace, or readjust guy material, stakes, and posts as required or directed by the Engineer. The Contractor shall reshape plant saucers, repair washouts and gullies, replace lost wood chip mulch, keep all planting sites free from weeds and do other work necessary to maintain the plants in a healthy and vigorous growing condition. This includes seasonal spraying or deep root watering with approved insecticides or fungicides as required.

1. Watering in Irrigated Areas. Trees planted at all locations on the project shall be watered once per month at the rate of 30 gallons per tree for the months November through April until the Landscape Establishment period ends.

Shrubs planted at all locations on the project shall be watered once per month at the rate of 10 gallons per shrub for the months November through April until the Landscape Establishment period ends.

2. Watering in Non-irrigated Areas. Trees planted shall be watered twice per month by the Contractor at the rate of 30 gallons per tree per watering for the months May through October, and once per month at the rate of 30 gallons per tree for the months November through April of the 12 month period following planting.

Shrubs planted in upland areas shall be watered twice per month by the Contractor at the rate of 10 gallons per shrub per watering for the months May through October, and shall be watered once per month at the rate of 10 gallons per shrub for the months November through April of the 12 month period following planting.

The contract performance bond, required by subsection 103.03, shall guarantee replacement work during the plant establishment period.

If all other work is completed on a project, no contract time will be charged during the plant establishment period.

METHOD OF MEASUREMENT

214.05 The quantity of planting to be measured will be the number of plants, of the types and sizes designated in the Contract, that are actually planted and accepted.

The quantity of brush layer cuttings will be measured by the actual number planted, complete in place and accepted.

Landscape Maintenance will not be measured, but will be paid for on a lump sum basis.

BASIS OF PAYMENT

214.06 The accepted quantities of planting, and brush layer cuttings will be paid for at the contract unit price for each of the various items listed below that appear in the bid schedule.

Payment for the total cost of the item will be made at the completion of planting.

Cost of the performance bond shall be included in the cost of the plant items.

Payment will be made under:

Pay Item	Pay Unit
_____ Tree ____ Inch Caliper	Each
_____ Tree ____ Foot	Each
_____ Shrub (____ Gallon Container)	Each
Perennials (____ Quart Container)	Each
Perennials (____ Gallon Container)	Each
Brush Layer Cuttings	Each
Landscape Maintenance	Lump Sum r

Water required for all items of work will not be measured and paid for separately, but shall be included in the work.

Payment shall be full compensation for all work necessary to complete the item.

For each month that landscape maintenance is performed and accepted during the landscape maintenance period as specified in subsection 214.04, payment for landscape maintenance will be made in installments as follows:

- (1) 10 percent of the lump sum amount will be paid for each of the eight growing season months, March through October.
- (2) 5 percent of the lump sum amount will be paid for each of the winter months, November through February.

Landscape maintenance performed during construction will not be measured and paid for separately, but shall be included in the work.

Landscape Establishment, except for landscape maintenance, will not be paid for separately, but shall be included in the work.

SECTION 216 SOIL RETENTION COVERING

DESCRIPTION

216.01 This work consists of furnishing, preparing, applying, placing, and securing soil retention blankets and turf reinforcement mats for erosion control on roadway slopes or channels as designated in the Contract.

MATERIALS

216.02 Soil retention covering shall be either a soil retention blanket or a turf reinforcement mat as specified in the Contract. It shall be one of the products listed on CDOT's Approved Products List and shall conform to the following:

- (a) *Soil Retention Blanket.* Soil retention blanket shall be composed of degradable natural fibers mechanically bound together between two slowly degrading synthetic or natural fiber nettings to form a continuous matrix and shall conform to the requirements of Tables 216-1 and 216-2. The blanket shall be of consistent thickness with the fiber evenly distributed over the entire area of the mat.

When specified, lightweight polypropylene netting shall be 1.5 pounds per 1000 square feet; heavyweight netting shall be 2.9 pounds per 1000 square feet.

When biodegradable blanket is specified, the thread shall be 100 percent biodegradable; polypropylene thread is not allowed.

When photodegradable netting is specified, the thread shall be polyester, biodegradable or photodegradable.

Blankets and nettings shall be non-toxic to vegetation and shall not inhibit germination of native seed mix as specified in the Contract. The materials shall not be toxic or injurious to humans. Class 1 blanket shall be an extended term blanket with a typical 24 month functional longevity. Class 2 blanket shall be a long term blanket with a typical 36 month functional longevity. The class of blanket is defined by the physical and performance characteristics.

1. *Soil Retention Blanket (Straw-Coconut).* Soil Retention Blanket (Straw-Coconut) shall be a machine produced mat consisting of 70 percent certified weed free agricultural straw or Colorado native grass straw and 30 percent coconut fiber. The blanket shall be either biodegradable or photodegradable. Blankets shall be sewn together on a maximum 2 inch centers.

Netting shall be as follows:

When biodegradable netting is specified, the top and bottom netting shall be 100 percent biodegradable organic jute fiber. Netting shall be constructed using a weave unattached at intersections which allows the strands of the net to move independently of each other.

When photodegradable netting is specified, the bottom side shall be lightweight polypropylene. The top side shall be heavyweight or lightweight polypropylene.

2. *Soil Retention Blanket (Excelsior)*. Soil Retention Blanket (Excelsior) shall consist of a machine produced mat of 100 percent curled wood excelsior, 80 percent of which shall be 6 inches or longer in fiber length. It shall be either biodegradable or photodegradable. Blankets shall be sewn together at a maximum of 4 inch centers.

Netting shall be as follows:

When biodegradable netting is specified, the top and bottom netting shall be 100 percent biodegradable organic jute fiber. Netting shall be constructed using a weave unattached at intersections which allows the strands of the net to move independently of each other.

When photodegradable netting is specified, the bottom side shall be lightweight polypropylene. The top side shall be heavyweight or lightweight polypropylene.

3. *Soil Retention Blanket (Coconut)*. Soil Retention Blanket (Coconut) shall be a machine produced mat consisting of 100 percent coconut fiber. It shall be either biodegradable or photodegradable.

Netting shall be as follows:

When biodegradable netting is specified, the top and bottom netting shall be 100 percent biodegradable organic jute fiber. Netting shall be constructed using a weave which is unattached at the intersections, and which allows the strands of the net to move independently of each other.

When photodegradable netting is specified, the bottom and top side shall be heavyweight polypropylene.

**Table 216-1
PHYSICAL REQUIREMENTS
FOR SOIL RETENTION BLANKET –
PHOTODEGRADABLE OR BIODEGRADABLE BLANKETS**

Photo/Bio Degradable Class	Minimum Roll Width	Minimum Thickness ASTM D6525	Acceptable Matrix Fill Material	Min. Mass per Unit Area ASTM D6475	Size of Net Opening	
					Photo-degradable	Bio-degradable
1	6.5 ft.	250 mils	Straw/Coconut	8 oz/sy	Minimum: 0.50"x0.50"	Minimum: 0.50"x0.50"
					Maximum: 0.75"x0.75"	Maximum: 0.5"x1.0"
1	6.5 ft.	250 mils	Excelsior	8 oz/sy	Minimum: 0.50"x0.50"	NONE
					Maximum: 1.0"x2.0"	
2	6.5 ft.	200 mils	Coconut	8oz/sy	Minimum: 0.50" x0.5"	Minimum: 0.50"x0.50"
					Maximum: 0.75"x0.75"	Maximum: 0.5"x1.0"

**Table 216-2
PERFORMANCE REQUIREMENTS
FOR SOIL RETENTION BLANKET –
PHOTODEGRADABLE OR BIODEGRADABLE BLANKETS**

Photo/Bio Degradable Class	Slope Application "C" Factor ¹ ASTM D6459	Minimum Tensile Strength MD ² ASTM D6818
1	< <u>0.10 at 3:1</u>	8.33 lb/in
2	< <u>0.10 at 3:1</u>	10.42 lb/in

Notes:
¹ "C" Factor is calculated as ratio of soil loss from soil retention blanket protected slope (tested at specified or greater gradient, 3H:1V) to ratio of soil loss from unprotected (control) plot in large-scale testing.
² MD is for machine direction testing (along the length of the roll).

Blankets shall be tested for physical properties and have published data from an independent testing facility.

Large scale testing of Slope Erosion Protection ("C" factor) shall be performed by an independent testing facility.

- (b) *Turf Reinforcement Mat.* Turf reinforcement mat (TRM) shall be a rolled mat consisting of UV stabilized, corrosion resistant, non-degradable synthetic fibers, filaments, or nets processed into a permanent three-dimensional matrix of the thickness specified in Tables 216-3 and 216-4. TRMs shall provide sufficient thickness, strength and void space to permit soil filling and retention, and the development of vegetation within the matrix. The class of TRM is defined by the physical and performance characteristics as specified in the following tables.

Table 216-3
PHYSICAL REQUIREMENTS¹
FOR TURF REINFORCEMENT MAT

Product Class	Minimum Roll Width	Minimum Thickness ASTM D6525	Acceptable Matrix Fill Material²	Size of Net Opening²
1	6.5 ft.	250 mils	Excelsior, Straw/Coconut, Coconut, or Polymer fibers	Minimum: 0.50"x0.50"
				Maximum: 0.75"x0.75"
2	6.5 ft.	250 mils	100% UV Stabilized Synthetic or Coconut Fibers	Maximum 0.50"x 0.50"
3	6.5 ft.	250 mils	100% UV Stabilized Synthetic Fibers	Maximum 0.50"x 0.50"
Notes:				
¹ For TRMs containing degradable components, all property values shall be obtained on the non-degradable portion of the matting alone.				
² For TRMs with nets and fill material. Netted TRMs shall be sewn together on a maximum 2 inch centers.				

Table 216-4
PERFORMANCE REQUIREMENTS
FOR TURF REINFORCEMENT MAT

Product Class	Tensile Strength MD ASTM D6818	Minimum UV Stability at 500 Hours ASTM D4355	Minimum Permissible Shear Stress ¹ (Unvegetated) ASTM D6460
1	125 lbs/ft	80%	1.8 lbs/sf
2	150 lbs/ft	80%	2.5 lbs/sf
3	175 lbs/ft	80%	3.1 lbs/sf

Notes:
¹ Permissible shear stress is the minimum shear stress that a product must be able to sustain when placed on a channel un-vegetated without physical damage or excess soil loss. Failure is defined as ½ inch of soil loss during a 30 minute flow event in large scale testing.

TRMs shall be tested for physical properties and have published data from an independent testing facility.

Large scale testing of Permissible Shear Stress shall be performed by an independent testing facility.

- (c) *Staples.* Staples shall be made of ductile steel wire, 0.165 inches in diameter, 8 inches long and have a 1 inch crown. "T" shaped staples will not be permitted.

A sample of the staples and a Certificate of Compliance (COC) including the manufacturer's product data showing that the product meets the Contract requirements shall be submitted for approval at the Environmental Pre-construction Conference. Installation of the blanket will not begin until approval has been received from the Engineer in writing.

- (d) *Earth Anchors.* The mechanical earth anchor shall be composed of a load bearing face plate, a tendon rod or wire rope, and a locking head or percussion anchor. Each element of the anchor shall be composed of corrosion resistant materials. The anchor and wire rope shall have a breaking strength of 9,500 pounds utilizing standard tensile testing and ASTM A1007-07. The anchor shall have a minimum 1,000 pounds ultimate holding strength in normal soil and a manufacturer's recommended minimum driven depth of 3.5 feet.

A sample of the anchors and a Certificate of Compliance (COC) including the manufacturer's product data showing that the product meets the Contract requirements shall be submitted for approval at the Environmental Pre-construction Conference. Installation of the blanket will not begin until approval has been received from the Engineer in writing.

CONSTRUCTION REQUIREMENTS

216.03 The Contractor shall install soil retention coverings in accordance with Standard Plan M-216-1 and the following procedure:

- (1) Prepare soil in accordance with subsection 212.06 (a).
- (2) Apply topsoil or soil conditioning as directed in the Contract to prepare seed bed.
- (3) Place seed in accordance with the Contract.
- (4) Unroll the covering parallel to the primary direction of flow.
- (5) Ensure that the covering maintains direct contact with the soil surface over the entirety of the installation area.
- (6) Do not stretch the material or allow it to bridge over surface inconsistencies.
- (7) Staple the covering to the soil such that each staple is flush with the underlying soil.
- (8) Ensure that staples or earth anchors are installed full depth to resist pull out. No bent over staples will be allowed. Install anchor trenches, seams, and terminal ends as shown on the plans.

The Contractor shall install TRMs using the following procedure:

- (1) Place 3 inches of topsoil or soil amended with soil conditioning.
- (2) Apply half of the specified seed at the broadcast rate and rake it into the soil.
- (3) Install TRM.
- (4) Place 1 inch of topsoil or soil amended with soil conditioning into the matrix to fill the product thickness.
- (5) Apply the remaining half of the specified seed at the broadcast rate and rake it into the soil.
- (6) Install soil retention blanket (Photodegradable or Biodegradable Class 1) over the seeded area and TRM.

When applicable, the covering shall be unrolled with the heavyweight polypropylene netting on top and the lightweight polypropylene netting in contact with the soil.

216.04 Slope Application. Soil retention coverings shall be installed on slopes as follows:

The upslope end shall be buried in a trench 3 feet beyond the crest of the slope if possible. Trench depth shall be a minimum of 6 inches unless required by the manufacture to be deeper. Before backfilling begins, staples shall be placed across the width of the trench. The trench shall then be backfilled to grade with soil amended with soil conditioning or topsoil, compacted by foot tamping, and seeded. Fabric shall be brought back over trench and secured with staples or earth anchors at 1 foot on center.

There shall be an overlap wherever one roll of fabric ends and another begins with the uphill covering placed on top of the downhill covering. Staples shall be installed in the overlap.

There shall be an overlap wherever two widths of covering are applied side by side. Staples shall be installed in the overlap.

Staple checks shall be installed on the slope length at a maximum of every 35 feet. Each staple check shall consist of two rows of staggered staples.

The down slope end shall be buried in a trench 3 feet beyond the toe of slope. Before backfilling begins, staples shall be placed across the width of the trench. The trench shall then be backfilled to grade with soil amended with soil conditioning or topsoil, compacted by foot tamping, and seeded. Fabric shall be brought back over the trench and secured with staples or earth anchors. If a slope runs into State waters or cannot be extended 3 feet beyond the toe of slope, the end of covering shall be secured using a staple check as described above.

Coverings shall be securely fastened to the soil by installing staples or earth anchors at the minimum rate shown on the Standard Plan M-216-1. Staple or earth anchor spacing shall be reduced where required due to soil type or steepness of slope.

216.05 Channel Application. Soil retention coverings shall be installed as follows on a channel application:

Coverings shall be anchored at the beginning and end of the channel across its entire width by burying the end in a trench. Trench depth shall be a minimum of 6 inches, unless a larger depth is specified by the manufacturer's recommendations. Before backfilling begins, staples shall be placed across the width of the trench. The trench shall then be backfilled to grade with soil amended with soil conditioning or topsoil and compacted by foot tamping, and seeded. Fabric shall be brought back over the trench and stapled.

Covering shall be unrolled in the direction of flow and placed in the bottom of the channel first. Seams shall not be placed down the center of the channel bottom or in areas of concentrated flows when placing rolls side by side.

There shall be an overlap wherever one roll of covering ends and another begins with the upstream covering placed on top of the downstream covering. Two rows of staggered staples shall be placed.

There shall be an overlap wherever two widths of covering are applied side by side. Staples shall be placed in the overlap.

The covering shall have a channel check slot every 30 feet along the gradient of the flowline. Check slots shall extend the entire width of the channel. The covering shall be buried in a trench. Before backfilling begins, staples shall be placed across the width of the trench. The trench shall then be backfilled to grade with soil amended with soil conditioning or topsoil, compacted by foot tamping, and seeded. Fabric shall be brought back over the trench and continued down the channel.

Coverings shall be securely fastened to the soil by installing staples at the minimum rate shown on the plans. Staple spacing shall be reduced where needed due to soil type or high flows.

216.06 Maintenance. The Contractor shall maintain the soil retention coverings until all work on the Contract has been completed and accepted. Maintenance shall consist of the repair of areas where damage is due to the Contractor's operations. Maintenance shall be performed at the Contractor's expense. Repair of those areas damaged by causes not attributable to the Contractor's operations shall be repaired by the Contractor and will be paid for at the contract unit price. Areas shall be repaired to reestablish the condition and grade of the soil and seeding prior to application of the covering.

METHOD OF MEASUREMENT

216.07 Soil retention coverings, including staples, complete in place and accepted, will be measured by the square yard of finished surface, excluding overlap, which is installed and accepted. Earth anchors will be measured by the actual number of earth anchors complete in place and accepted.

BASIS OF PAYMENT

216.08 The accepted quantities of soil retention coverings will be paid for at the contract unit price per square yard. The accepted quantities of earth anchors will be paid for at the contract unit price for each installed.

Payment will be made under:

Pay Item	Pay Unit
Soil Retention Blanket () (Photodegradable Class)	Square Yard
Soil Retention Blanket () (Biodegradable Class)	Square Yard
Turf Reinforcement Mat (Class)	Square Yard
Earth Anchors	Each

Preparation of seedbed, fertilizing, and seeding will be measured and paid for in accordance with Section 212.

Placing and preparation of seedbed, fertilizing, and seeding of soil under the TRM layer will be measured and paid for in accordance with Section 212.

Topsoil or amended soil and seed placed on the TRM will be measured and paid for in accordance with Sections 207 and 212.

Staples will not be measured and paid for separately, but shall be included in the work.

SECTION 250 ENVIRONMENTAL, HEALTH AND SAFETY MANAGEMENT

DESCRIPTION

250.01 This work consists of protection of the environment, persons, and property from contaminants that may be encountered on the Project. This includes monitoring the work for encounters with contaminants or suspected soil and groundwater contaminants; the management of solid, special, and hazardous waste; and management of visual emissions associated with hazardous waste, when encountered on the project.

250.02 The Contractor shall furnish all personnel, materials, equipment, laboratory services, and traffic control necessary to perform the contamination monitoring, testing, and site remediation when required. Traffic control shall be in accordance with the requirements of Section 630.

Monitoring equipment used to detect flammable gas, oxygen level, and toxic gas shall be capable of detection to meet the following standards:

Instrument Detection		
Constituent	Threshold Limit	Increments
Flammable Gas	1% LEL	1%
Oxygen	19%	0.1%
Toxic Gas	1 PPM	1 PPM
LEL = lower explosive limit PPM = parts per million		

CONSTRUCTION REQUIREMENTS

250.03 General. Prospective bidders, including subcontractors, are required to review the environmental documents available for this project. These documents are listed in subsection 102.05 as revised for this project.

This project may be in the vicinity of property associated with petroleum products, heavy metal based paint, landfill, buried foundations, abandoned utility lines, industrial area or other sites which can yield hazardous substances or produce dangerous gases. These hazardous substances or gases can migrate within or into the construction area and could create hazardous conditions. The Contractor shall use appropriate methods to reduce and control known landfill, industrial gases, and visible emissions from asbestos encounters and hazardous substances which exist or migrate into the construction area. The Contractor shall follow CDOT's *Asbestos-Contaminated Soil Management Standard Operating Procedure, dated August 22, 2011* for proper handling of asbestos-contaminated soil, and follow all applicable Solid and Hazardous Waste Regulations for proper handling of soils encountered that contain any other substance mentioned above.

Encountering suspected contaminated material, including groundwater, old foundations, building materials, demolition debris, or utility lines that may contain asbestos or be contaminated by asbestos, is possible at some point during the construction of this project. When suspected contaminated material, including groundwater, is encountered or brought to the surface, the procedures under subsection 250.03(d) and 250.05 shall be followed.

Transportation of waste materials on public highways, streets and roadways shall be done in accordance with Title 49, Code of Federal Regulations (CFR). All labeling, manifesting, transportation, etc. of waste materials generated on this project shall be coordinated with the Engineer. All hazardous waste manifests for waste materials generated on this project shall list the Colorado Department of Transportation as the generator of the waste materials except as otherwise noted. If the Contractor contaminates the site, the Contractor shall be listed as the generator on the hazardous waste manifests, permits, and other documents for such material. If the project is not on a State Highway or frontage road, then the appropriate local governmental entity having jurisdiction over the transportation system facility shall be listed as the hazardous waste generator.

If waste materials must be handled in a permitted treatment, storage and disposal (TSD) facility, the facility shall be designated in writing by the Engineer. If the waste materials are the result of the Contractor's actions, the Contractor shall designate the facility.

The hazardous waste transportation phase of the work involves insurance required by law and regulations. If the waste materials are determined to be hazardous, the Contractor must submit proof that the transportation company is covered by the appropriate type and amount of insurance required by laws and regulations governing the transportation of hazardous waste.

The Contractor alone bears the responsibility for determining that the work is accomplished in strict accordance with all applicable federal, state, and local laws, regulations, standards, and codes governing special waste, petroleum, and hazardous substance encounters and releases.

The Contract will list known or suspected areas of contamination. Health and Safety Officer, Monitoring Technician, and Health and Safety Plan shall be required when so stated in the Contract.

- (a) *Health and Safety Officer (HSO)*. The Contractor shall designate a HSO, not the Project Superintendent, who shall have at least two years field experience in chemical related health and safety. The HSO shall be either a certified industrial hygienist (CIH), certified hazardous materials manager (CHMM), professional engineer (PE) licensed in the State of Colorado, certified safety professional (CSP), or registered environmental manager (REM) meeting the criteria set forth in 29 CFR 1926. When asbestos is present or is suspected to be present, the HSO shall have additional training and certification in accordance with the Air Quality Control Commission Regulation No. 8 Part B. The HSO shall meet the minimum training and medical surveillance requirements established by the Occupational Safety and Health

Administration (OSHA) and the Environmental Protection Agency (EPA) for a supervisory Site Safety Official per 29 CFR 1962.65. The Contractor shall furnish documentation to the Engineer, at the Pre-construction Conference, that the above requirements have been met.

The HSO shall be equipped with the following:

- (1) Communication equipment as required in subsection 250.03(d)2.A. and a vehicle.
- (2) Monitoring and detection equipment for flammable gas, oxygen sufficiency, toxic gas, radiological screening, and other hazards. This includes, as required, a combustible gas indicator, flame ionization or photo ionization detector, oxygen meter, radiation monitor with Geiger Mueller detector, and other foreseeable equipment.
- (3) Depth gauging equipment, sampling equipment, and sampling containers.
- (4) Personal protective equipment (levels C and D) when required.

The HSO shall recommend and supervise those actions which will minimize the risk of hazardous substance related injury to the workers, Department personnel, the general public, property, and the environment. Hazardous substance is defined in 29 CFR 1926.32. The HSO shall prepare written procedures for the monitoring of confined space entry and working in or near excavations, including but not limited to trenches and drill holes associated with this project. The HSO shall conduct or supervise all hazardous substance and solid waste related testing, sampling, monitoring, and handling for this project to ensure compliance with applicable statutes and regulations, and other applicable environmental requirements under subsections 107.01 and 107.02.

The HSO shall be available for consultation and assistance with contaminated materials related testing, sampling, and field monitoring as required by the Engineer.

The HSO shall prepare and submit a bound and indexed final site report to the Engineer at the end of the project. This site report shall include a detailed summary of all contaminated materials and contaminated water that were encountered and their final disposition.

During each week the HSO is utilized, the HSO shall prepare a daily diary which shall be submitted to the Contractor and the Engineer. This diary shall be submitted at the end of the week and shall become a part of the Department's records. The diary shall contain a chronological log of activities on the project including: dates and times on site, equipment used and calibrations, field monitoring results, visual observations, conversations, directives both given and received, and disposition of suspected hazardous substances. The Engineer will review this submittal and approve the actual number of hours to be paid.

- (b) *Monitoring Technician (MT)*. The Contractor shall designate a Monitoring Technician to be responsible for monitoring of hazardous substances during

work on the project. The MT shall have a minimum of two years of actual field experience in assessment and remediation of hazardous substances that may be encountered during highway construction projects. The MT shall be experienced in the operation of monitoring devices, identifying substances based upon experience and observation, and field sampling (for testing) of all media that may be found on the site. Completion of the 40 hour hazardous waste and 8 hour supervisory training required by OSHA and U.S. EPA rules and regulations which complies with the accreditation criteria under the provisions of the proposed 29 CFR 1910.121 is required prior to beginning work. The Contractor shall furnish documentation at the Pre-construction Conference that demonstrates these requirements have been met.

The MT shall be equipped with the following:

- (1) Communication equipment as required in subsection 250.03(d)2.A. and a vehicle.
- (2) Monitoring and detection equipment for flammable gas, oxygen sufficiency, toxic gas, radiological screening, and other hazards. This includes, as required, a combustible gas indicator, flame ionization or photo ionization detector, oxygen meter, radiation monitor with Geiger Mueller detector, and other foreseeable equipment.
- (3) Personal protective equipment (levels C and D) when required.

The MT shall be present on site and perform monitoring as required by 250.03(d) when work is being performed in areas of suspected contamination and on a predetermined basis throughout other work on the project.

The MT shall monitor for compliance with regulations, the project Health and Safety Plan and the Materials Management Plan (if they exist for the project), the Contract, and the environmental documents for the project. The MT shall immediately notify the Contractor, the Engineer, and the HSO of any hazardous condition.

During each week the MT is utilized, the MT shall prepare a daily monitoring diary which shall be submitted to the Contractor, HSO and the Engineer. This diary shall be submitted at the end of the week and shall become a part of the Department's records. The diary shall contain a chronological log of activities on the project including: dates and times on site, equipment used and calibrations, field monitoring results, visual observations, conversations, directives both given and received, and disposition of suspected hazardous substances. The Engineer will review this submittal and approve the actual number of hours to be paid.

- (c) *Health and Safety Plan (HASP)*. The HSO shall prepare a written HASP for the project, formatted as shown in Appendix B, Occupational Safety and Health Guidance Manual for Hazardous Waste Site Activities, DHHS (NIOSH) Publication Number 85-115, available from the Superintendent of Documents, U.S. Government Printing Office. The Contractor and the HSO shall review the

environmental documents listed prior to preparation of the HASP.

Four signed copies of the HASP shall be furnished to the Engineer for acceptance. The Engineer shall have seven calendar days to review and accept or reject the proposed HASP. Within five calendar days after acceptance, the HSO shall distribute signed and stamped (or sealed) copies of the accepted HASP to each emergency response agency servicing the project area, the HASP designated emergency hospital, and five copies to the Engineer. Earth or demolition work shall not occur until after the HASP is accepted and the HASP has been distributed. The HASP shall also be available to the Contractor's employees, their representatives, and officials of OSHA, EPA, Colorado Department of Public Health and Environment (CDPHE), local government health department, Federal Highway Administration, and other appropriate agencies and officials as may be designated by the Engineer. The Engineer will distribute the accepted HASP to appropriate Department personnel. The HASP shall be kept current and shall be revised by the HSO as warranted by changes in the field conditions.

All on-site workers (Contractor's, Department's, Utilities', and others) shall be briefed by the HSO on the contents of the HASP and any revisions thereof. The HSO shall conduct briefings (group or individual) to inform new employees, subcontractors, utility companies, and other on-site workers of the HASP contents prior to their entry on site. All personnel involved in excavation or other soil disturbing activities shall receive the required two-hour Asbestos Awareness training by a Certified Asbestos Inspector, when asbestos discoveries are anticipated or discoveries are made. A signature log of all briefing attendees shall be kept and furnished to the Engineer. The Contractor shall provide, as required, eye wash equipment and stations, emergency showers, hand and face washing facilities, and first aid equipment.

The Contractor shall provide, as required, decontamination facilities for personnel and equipment employed in the work. The exact procedure for decontamination and frequency shall be included in the accepted HASP. Decontamination facilities shall meet the criteria set forth in the Code of Federal Regulations (29 CFR and 40 CFR).

- (d) *Precautions and Procedures.* The following minimum precautions and procedures shall be followed during the construction of the project:
1. General construction precautions:
 - A. All monitoring and piezometer wells and test borings shall be established or abandoned by the Contractor as regulated by the State Engineer's Office. Copies of all required permits, notification, and abandonment documents shall be submitted to the Engineer prior to payment approval.
 - B. Hazardous substance related activities shall have a work plan for each work phase which shall be coordinated with the Engineer at least three

- working days prior to commencement of each phase of the work.
- C. The Contractor shall properly handle all investigation derived waste generated by this project. Documentation shall be submitted to the Engineer of all tests performed for Treatment, Storage, and Disposal (TSD) determination; classification of waste; hauling records; TSD acceptance; manifest (if required); etc. in accordance with applicable laws and regulations.
 - D. When the work may involve air emissions, the Contractor shall contact the Colorado Department of Public Health and Environment (CDPHE), Air Pollution Control Division to ascertain if an air pollution emission notice (APEN) or permit is required for this operation. The Contractor shall be responsible for filing the APEN and obtaining said permit, if required. The processing of air pollution permits, if required, in non-attainment areas or where public hearings are required, likely will take more than 90 days.
2. For construction on a known or potentially contaminated site, the following conditions shall apply, in addition to those listed in subsection 250.03(d)1:
 - A. The HSO shall be on site or readily available by radio, telephone or pager at all times during the work. When on site, the HSO shall have an operational portable or mobile cellular telephone available for immediate use in areas where such service is available. When on site in cellular telephone non-service areas, the HSO shall have available, for immediate use, radio access to a site with telephone service. The HSO shall be notified at least 24 hours prior to the start of confined space entry, storage tank removal, drilling, excavation, trenching, or dewatering operations.
 - B. The HSO shall designate the onsite monitoring equipment for flammable gases, oxygen deficient or enriched atmosphere, and toxic gases, such as but not limited to, a flame ionization detector, photoionization detector, combustible gas indicator, and oxygen meter. This designated equipment shall be on site during all construction operations and be utilized during trenching, drilling, excavating, confined space entry, underground storage tank removal, and other appropriate construction operations. The exact equipment to fulfill this requirement shall be specified in the accepted HASP. The HSO shall conduct or supervise the monitoring. The monitoring equipment shall be calibrated as recommended by the manufacturer.
 - C. When drilling, trenching, or excavating in the presence of detectable concentrations of explosive gases, the soil shall be wetted and the operating equipment shall be provided with spark proof exhausts.
 - D. The Contractor, through the HSO, is responsible for ensuring that 29 CFR 1926 is fully complied with during the construction of the project.

- E. Affected excavation operations shall be discontinued and personnel shall be removed from the affected excavation sites where any of the following levels are detected:
 - (1) 20.0 percent or more LEL flammable gas, or 10.0 percent in an underground or confined space,
 - (2) Permissible Exposure Limit (PEL) of any toxic gas,
 - (3) 19.5 percent or less oxygen,
 - (4) 25.0 percent or more oxygen,
 - (5) Greater than 2 mrem/hr. (Beta particle & photon radioactivity),
 - (6) Greater than 15 pCi/L (Gross alpha particle activity), or
 - (7) Other action levels as determined by the HSO.
 - (8) Uncovering of suspect Asbestos Containing Material (ACM), including but not limited to, buried facility components, active or abandoned utility lines, buried foundations and demolition debris, or miscellaneous ACM dispersed in the soil. The Contractor shall follow the procedures outlined in the HASP and 29 CFR 1926 to address these conditions. Work shall resume in these areas when approved by the Engineer.
 - F. Personnel shall be issued and utilize appropriate health and safety equipment as determined by the HSO, who shall provide the Engineer with a written explanation of what personal protective equipment (PPE) shall be worn, when, and by which personnel. Except in emergency cases, the Engineer shall be advised by the HSO of changes in the degree of PPE prior to implementation.
 - G. Personnel shall avoid the area immediately downwind of any excavation unless the excavation is monitored and declared safe.
 - H. The operators of excavating, trenching, or drilling equipment shall wear appropriate PPE as required in the HASP.
 - I. Exhaust blowers shall be present at the location where required in the accepted HASP.
 - J. The Contractor shall accomplish the work with employees who have been trained and equipped as required by the HASP and applicable provisions of 29 CFR 1910 and 29 CFR 1926.
 - K. Fire extinguishers, electrical equipment and wiring shall conform to the applicable requirements of 29 CFR 1926 and 49 CFR.
 - L. Smoking shall not be permitted within 50 feet of any excavation.
3. For construction within 1000 feet of a known or potentially contaminated site, the following conditions, in addition to those listed in subsection 250.03(d)1. shall apply:

- A. The areas under construction shall be checked with a combustible gas indicator before excavation begins to determine if flammable or combustible gas is in the area.
 - B. Excavations, trenches and drill holes shall be monitored by the HSO for flammable gas, toxic gas and oxygen deficiency or enrichment. This shall be carried out continuously unless the presence of flammable, combustible, or toxic gas or oxygen deficiency or enrichment in the area can be ruled out by the HSO. The recommendation to discontinue monitoring must be agreed to by the Engineer and the Contractor. Prior to implementation, this agreement shall be written, and shall contain specific conditions that will require re-evaluation of the area.
 - C. When flammable or toxic gas is found in the area, those precautions and procedures in subsection 250.03(d)2 shall apply.
4. The following procedures shall be followed if the level of contamination as documented in the environmental documents referenced in subsection 102.05 as revised for this project is exceeded, or if previously unidentified contaminated air, soil or water, is encountered during the construction of the project:
- A. Work in the immediate area of the release or discovery of contamination shall cease. The Engineer shall be immediately notified.
 - B. If no HSO is required by the Contract, the Contractor shall designate an HSO as directed, in accordance with subsection 250.03(a).
 - C. The Engineer may direct the HSO to evaluate the material for potential hazardous substance or other contamination or unsafe conditions. This evaluation may include, but is not limited to, on site field monitoring, on site testing, and on or off site laboratory analysis. Removal of storage tanks and surrounding contaminated soils shall be in accordance with applicable laws, regulations and established procedures. If the contaminated material cannot be placed in the embankment or remediated on site, it must be removed to an appropriate TSD facility, as designated in writing by the Engineer. The HSO shall supervise the necessary testing required to make appropriate TSD determinations. Disposal of the unsuitable material shall be considered as remediation work as described in subsection 250.03(d)4.D and 250.03(d)4.E.
 - D. If this site is determined to be contaminated with petroleum products, hazardous substances or other solid waste in excess of that indicated in the above listed site investigation documents, a thorough Site Investigation and Waste Management Plan shall be accomplished under the supervision of the HSO. The Site Investigation and Waste Management Plan shall be submitted to the Engineer for approval and shall determine the extent of

contamination and propose at least three types of remedial action for the contaminated area as required by applicable statutes and regulations. The HSO shall be available to assist the Engineer in explaining this study to the regulatory agencies. When requested by the Engineer, the Contractor shall prepare a Remediation Plan based on the selected remedial method, and shall submit this to the Engineer for approval. The time required for the Engineer's review of the Remediation Plan, including all necessary drawings, calculations, specifications, and other documentation will not exceed four weeks after a complete submittal is received. This work shall not be done unless authorized in writing by the Engineer.

- E. If the site is determined to be contaminated with petroleum products; hazardous chemicals, materials, or wastes; or other solid wastes, and is required to be remediated, the HSO or other qualified individuals will supervise the Remediation Plan implementation as concurred to by the regulatory agencies, as directed. Hazardous Waste generated by remedial activities shall list the Colorado Department of Transportation as the hazardous waste generator on the required paperwork for projects on State Highways and their associated frontage roads. If this project is not on a State Highway or frontage road, then the appropriate local governmental entity having jurisdiction over the transportation system facility shall be listed as the hazardous waste generator. If the waste disturbed or produced was caused by Contractor negligence, the Contractor shall be listed as the hazardous waste generator. Remediation work shall be done only when authorized by the Engineer in writing.

250.04 Heavy Metal Based Paint Management. When the work includes the removal of paint or items covered with paint which may contain lead, chromium or other heavy metals, the requirements of this subsection shall apply in addition to the requirements of subsection 250.03.

The requirements of the HASP shall be in accordance with OSHA Publication Number 3142, Working with Lead in the Construction Industry.

Paint Removal and Waste Disposal work shall be performed in accordance with 29 CFR 1926.62, State and local air quality regulations, the Steel Structures Painting Council (SSPC) Guide for Containing Debris Generated During Paint Removal Operations, the Industrial Lead Paint Removal Handbook (SSPC 91-18), and the references contained therein.

The following minimum precautions and procedures shall be followed unless modified in the approved HASP or its updates:

- (a) The Contractor shall contact the CDPHE, Air Pollution Control Division to ascertain if an air pollution permit is required for the cleaning or demolition work. If an air pollution permit is required, the Contractor shall obtain the permit. The Contractor shall furnish the Engineer with a copy of the permit application and the permit issued prior to starting cleaning or demolition activities. A copy of the Air Pollution Emission Notice [APEN] shall be

provided to the Engineer, if such notice is required under the Colorado Air Quality Control Commission's regulations. The processing of air pollution permits in non-attainment areas, or where public hearings are required, likely will take more than 90 days.

- (b) The Contractor shall contain paint chips, corrosion residues, and spent abrasives, herein referred to as waste materials, resulting from the cleaning or demolition operations. The Contractor shall not deposit or release waste material into the water, air or onto the ground below or adjacent to the structure. The Contractor shall conduct cleaning operations to minimize the waste materials produced. Prior to beginning the work, the Contractor shall submit to the Engineer for acceptance, a detailed methods statement for capturing, testing, and disposing of the removed materials. The Engineer will have seven calendar days to review, and accept or reject this methods statement.
- (c) Abrasives utilized for blast cleaning shall be low-dusting and low waste. Unless approved otherwise, vacuum blasting or wheel blasting shall be used.
- (d) The HSO shall sample and test the waste material for lead, chromium, and other paint associated heavy metals using the Toxicity Characteristic Leaching Procedure (TCLP) Test, Method 1311 of the EPA publication, Test Methods for Evaluating Solid Waste 846. Sample collection methodology and frequency shall be recommended by the HSO and accepted by the Engineer with an adequate number of samples taken to be representative of all waste material collected. If the waste material does not pass the TCLP test, it shall be disposed of in a permitted TSD facility as designated in writing by the Engineer. The waste materials handling decision shall be documented by a report (five copies) submitted to the Engineer. This documentation shall include a description of sample collection methodology, testing performed, test results, and comparison of test results with hazardous waste requirements. The waste material shall not be held at an unpermitted TSD facility site in excess of Resource Conservation and Recovery Act (RCRA) temporary storage time limits.
- (e) When an item coated with paint is removed, all loose paint shall be removed and collected from the item within 24 hours of the time it is removed or placed onto the ground. All loose paint shall be removed and collected from a painted item before it is removed from the site. The Contractor shall contain loose paint until it is removed and collected. Loose paint is defined as that which can be removed by manual scraping methods. Over waterways, the Contractor shall capture all paint debris by the method specified in the methods statement. The paint debris shall be collected on a daily basis and shall be stored in a properly labeled, tightly sealed container and placed in a secured location at the end of each working day.
- (f) All painted steel components which are not designated to be salvaged shall be recycled. Contractor possession of the steel for future use shall be considered a form of recycling. Prior to transport of the components off-site, the Contractor shall obtain a letter from the recipients of the painted steel

components stating that they have been fully informed of the contents of the paint and are capable of handling the paint. If the Contractor is to maintain future possession of the steel, the Contractor shall supply this letter. If there will be more than one recipient of the painted material, one letter shall be obtained from each recipient. The Contractor shall provide a copy of each letter to the Engineer. If the painted steel components will be recycled by melting, the letter from the recipient is not required. The Contractor shall submit a letter stating the destination of the painted steel components and that they will be melted.

(g) When the work consists of the removal of a bridge or components of a bridge coated with paint which has been assumed to contain lead, chromium, other heavy metals, or a combination thereof, the Contractor shall capture paint debris which is dislodged during removal operations. The Contractor may choose any method for dismantling the bridge, subject to the following required construction sequence limitations:

- (1) The concrete deck shall be removed prior to removal of the steel superstructure.
- (2) If the methods statement indicates that girders will be dropped to the ground during dismantling, all debris from the concrete deck removal operation shall be removed from the area below the bridge before any girders are dropped into this area.
- (3) Girders may be cut and dropped only if the span is located entirely over land.

250.05 Material Handling. This work consists of the additional handling of groundwater and soils to be excavated for construction of the project which are suspected or known to be contaminated. This work also includes stockpiling or containerization, analytical sampling and testing, and final disposition of contaminated groundwater and soils requiring special handling.

The Contractor shall maintain vertical trench walls for the work in the specified areas of known or potential contamination, as shown on the plans. Shoring may be necessary to meet this requirement. The Contractor shall confine the removal of contaminated groundwater and soils encountered as a result of the excavation activities in the specified areas to the vertical and horizontal limits of structure excavation specified in the Contract. The Contractor shall be responsible for any contaminated materials generated beyond the limits of excavation. This shall include any sampling, analysis, and disposal required, and the costs thereof. The Contractor shall be listed as the generator of any such material. The limits of excavation shall be determined as 18 inches outside of structures, including sewers, water lines, inlets, manholes, and other underground structures to be constructed, or as directed.

Specific areas of known or potential contamination have been identified in the project plans. There is the potential of encountering contaminated groundwater and soil, which has not been summarized in the plans or specifications, at unknown locations on the site. Suspected contaminated soil and groundwater shall be handled by one of three methods as follows:

- (a) *Materials Handling (Stockpile & Containerization)*. When recommended by the HSO and authorized by the Engineer, material shall be stockpiled or containerized for analysis and characterization for proper handling and, disposal, or both. Sampling and testing of materials shall be as described in the Contract. If analysis indicates that soil samples are designated as uncontaminated, as determined by the criteria shown in the Contract or as determined by the CDPHE, the associated soils will not require any special handling and will become the property of the Contractor and may be used on site, subject to other requirements of the Contract. Health and safety monitoring and strict fugitive dust control shall be conducted during the placement of these soils. If analysis indicates that groundwater samples are designated as uncontaminated, as determined by the criteria shown in the Contract or as determined by the CDPHE, the groundwater shall be handled in accordance with subsection 107.25.

Stockpiled and containerized materials shall be secured in compliance with the following provisions until they are determined to be uncontaminated:

- (1) The Contractor shall not store the material for more than 90 days.
 - (2) The Contractor shall prevent any runoff from infiltrating the ground or running out of the containment area.
 - (3) Soils and groundwater containing different contaminants shall be placed in separate containers or stockpiles.
 - (4) The Contractor shall prevent the dispersion of materials or the dilution or mixing of containers and stockpiles.
 - (5) The ground surface on which the contaminated soils will be placed shall be covered with plastic sheeting which will withstand the placement and removal of stockpiled materials without breaching.
 - (6) The ground surface shall be graded to drain toward the edge of the soil piles and the berm or trench around them shall be covered by plastic sheeting.
 - (7) Proper security shall be provided in accordance with 40 CFR.
- (b) *Solid Waste Disposal*. Soils determined to be contaminated, but not hazardous, as established by criteria in the Contract or as determined by CDPHE or other regulatory agencies having jurisdiction, shall be handled and disposed of as recommended by the HSO and approved by the Engineer. The Contractor shall haul this material to a solid waste disposal facility.
- (c) *Contaminated Groundwater Disposal*. Groundwater determined to be contaminated, but not hazardous, as established by criteria in the Contract or as determined by CDPHE or other regulatory agencies having jurisdiction, shall be handled and disposed of as recommended by the HSO and approved

by the Engineer. The Contractor shall prepare a dewatering plan proposing at least three types of treatment and/or disposal options of contaminated groundwater as required by applicable statutes and regulations. One of the treatment options shall include permitting and onsite treatment prior to discharge or disposal. The dewatering plan shall be submitted to the Engineer for approval four weeks before dewatering activities begin.

- (d) *Hazardous Waste Disposal.* Soils and groundwater that are designated or suspected to be hazardous shall be containerized immediately upon excavation or upon discovery. Hazardous material shall be labeled and transported to a permitted treatment, storage and disposal (TSD) facility or to a hazardous waste disposal facility approved by the Engineer.
- (e) *Additional Requirements.* Stockpiled or containerized material characterized as uncontaminated, contaminated, or hazardous shall be stored and disposed of in a manner consistent with current established federal, state, and local regulations for waste materials.

Materials with contaminants not specifically regulated shall be disposed of by the Contractor as directed, in consultation with CDPHE. All areas where wastes are generated shall be reviewed by the HSO to identify potential contaminant sources that may result in a contaminated waste stream.

Contaminated groundwater and soils, which have been identified as solid waste or hazardous waste, requiring disposal according to federal, state, and local regulations, shall be transported in accordance with 49 CFR by the Contractor to an appropriately permitted treatment facility, landfill, incinerator, or asphalt plant or other facility approved to accept the waste. CDPHE and the landfill or other treatment or disposal facility shall be notified by the HSO of the material to be disposed of and the corresponding analytical test results prior to shipment. Potentially contaminated water collected from the lined trench of a stockpile shall be treated as required by Colorado Wastewater Discharge Permit System (CDPS) permits, 29 CFR and 40 CFR and reimbursed separately in accordance with Contract requirements.

250.06 Sample delivery. This work consists of the collection, containerization and delivery of material samples for analysis to the testing facility designated in the Contract.

Environmental Protection Agency (EPA) protocol and standards shall be followed in the collection, containerization, and transport of samples to be analyzed, including the documentation of the proper chain of custody of all samples. The Contractor shall collect sufficient sample material to perform the required analysis and is responsible for ensuring that appropriate climate control has been provided for sample transport. Sample delivery shall be made within the maximum allowable holding time for each sample type, not to exceed 24 hours, excluding weekends. The time period required for sample collection and delivery to the testing facility will not be considered an excusable delay. The analysis to be completed and turnaround time shall be approved by the Engineer.

The Contractor shall provide the Engineer with a copy of documentation indicating that proper chain of custody requirements have been followed for all samples.

Quality control samples shall be provided by the Contractor in accordance with the quality control requirements of the testing facility designated in the Contract (quality control requirements are available from the Engineer). The Contractor shall prepare, label, and transport these samples to the testing facility in conjunction with the delivery of other samples authorized for analysis by the Engineer, at no additional cost.

The Engineer may request splits of samples, in advance of collection, which shall be provided at no additional cost by the Contractor.

250.07 Asbestos-Containing Material Management. Environmental documents or plans listed in the special provisions include known or suspected locations that could involve encounters with ACM during excavation and other soil disturbing construction activities. Unexpected discoveries of ACM may be made during excavation and soil disturbing construction activities. Asbestos contaminated soil, shall be properly managed or remediated, in accordance with subsection 250.07(a).

All asbestos related activities shall be performed by Colorado certified asbestos professionals, contractors, or consultants. Certifications are issued by the Colorado Department of Public Health and Environment (CDPHE), Indoor Air Quality Unit. A Colorado Certified Asbestos professional shall manage the management and disposal of asbestos contaminated soil and other ACM. The Indoor Air Quality Unit within CDPHE is the only unit that certifies such professionals. The Contractor shall furnish a copy of the license to the Engineer.

- (a) *Regulatory Compliance.* Asbestos contaminated soil management is governed by 6 CCR 1007-2, Section 5, which includes and references regulatory compliance with Asbestos Hazard Emergency Response Act (AHERA) Colorado Regulation 8. Inspection and reporting protocol and demolition standards are governed by AHERA. Demolition and notification standards are governed by National Emission Standards for Hazardous Air Pollutants (NESHAPS). Colorado Regulation 8 governs all asbestos activities, demolition, permitting, and certification of Certified Asbestos Professionals in the State of Colorado. Colorado Regulation 8 is more stringent than AHERA and NESHAPS and supersedes federal regulations. Conflicting regulatory requirements between AHERA and NESHAPS, if not specifically addressed in Colorado Regulation 8, shall be addressed and approved protocol negotiated with CDPHE. The Contractor shall conform to all current regulations, policy directives, or both, issued by the EPA, CDPHE, and the Department.
- (b) *Asbestos Management and Visual Inspections* Asbestos management must be performed by a certified asbestos professional. Final Inspections of the area of asbestos contaminated soil removal shall be performed by an Asbestos Consultant to determine what, if any, controls must be instituted to allow future activity in the excavation area. All final visual inspections shall be conducted only when soil is dry.

- (c) *Permitting and Notification.* The CDPHE requires notification of any soil disturbing activity where asbestos is known, suspected, or discovered. A 24-hour notification to CDPHE is required prior to any soil disturbing activity of an unplanned asbestos discovery. A 10 working day notification to CDPHE is required prior to any soil disturbing activity in an area with known or potential material suspected of containing asbestos in or on the soil or asbestos-contaminated soil. Removal of asbestos-containing material on a facility component, that is located on or in soil that will be disturbed, with asbestos quantities above the following trigger levels must be permitted and abated in accordance with the requirements of Air Quality Control Commission Regulation No. 8 (5 CCR 1001-10, Part B):

- (1) 260 linear feet on pipes,
- (2) 160 square feet on other surfaces, or
- (3) The volume of a 55-gallon drum.

All permit applications shall be submitted to the Colorado Department of Public Health and Environment a minimum of 10 days prior to start of work for approval. The permit application and notification shall be submitted simultaneously. The Contractor shall obtain all required State and local permits and shall be responsible for all associated fees. Permit application, notification, and waiver request forms shall be submitted to:

Colorado Department of Public Health and Environment Permit
 Coordinator/APCD - SS - B1 4300 Cherry Creek Drive South Denver,
 CO 80246-1530 Phone: (303) 692-3100 Fax: (303) 782-0278

Application and waiver forms are available on the CDPHE website:

<https://www.colorado.gov/pacific/cdphe/asbestos-forms>

- (d) *CDOT's Asbestos-Contaminated Soil Management Standard Operating Procedure, dated August 22, 2011.* Asbestos contaminated soil shall be managed in accordance with 6 CCR 1007-2, Section 5, Asbestos Waste Management Regulations. Regulations apply only upon discovery of asbestos materials during excavation and soil disturbing activities on construction projects, or when asbestos encounters are expected during construction. The Contractor shall comply with procedures detailed in the CDPHE's Asbestos-Contaminated Soil Guidance Document and CDOT's approved Asbestos-Contaminated Soil Management Standard Operating Procedure, dated August 22, 2011, including the following minimum requirements:

- (1) Immediate actions and implementation of interim controls to prevent visible emissions, exposure, and asbestos contamination in surrounding areas.
- (2) Soil Characterization.

- (3) Training required for all personnel involved in excavation and other soil disturbing activities, once asbestos is encountered during construction or on projects where asbestos encounters are expected. Asbestos Awareness Training shall be given by a qualified and certified Asbestos Building Inspector with a minimum of six months experience inspecting asbestos contaminated soil.
- (4) Assessment for the presence and extent, within the proposed area of disturbance, of asbestos discoveries, whether expected or unexpected, by a Certified Asbestos Inspector.
- (5) Investigation and sampling required for risk assessment and management. Investigation, if required, shall be conducted by a Certified Asbestos Inspector.
- (6) Risk assessment and determinations for further management or abatement.
 - (i) Risk assessment and determinations must be made by a Certified Asbestos Inspector, and coordinated with the Engineer.
 - (ii) Soil remediation is not necessarily required, depending on the circumstances.
- (7) Submit 24-hour Notification of Unplanned Asbestos Discovery.
- (8) Submit 10-day Notification of Planned Asbestos Management.
- (e) *Risk Assessment and Determinations for Further Management Or Remediation.* Risk assessment and determinations for further management or remediation must be closely coordinated with the Project Engineer and Project Manager of the Statewide Management Plan.

250.08 Methamphetamine Lab Sites. Demolition of former Methamphetamine (meth) labs is enforced by the Governing Authority, which varies from county to county. The Contractor shall demolish all buildings that are identified as former meth labs, as listed in public listings by the Governing Authority. The Contractor shall provide evidence of demolition to the Governing Authority, obtain receipt of such evidence by the Governing Authority, and shall submit these to Engineer immediately following demolition.

Septic tank removal at known meth lab sites shall undergo preliminary assessment by an Industrial Hygienist or Certified Industrial Hygienist to determine proper removal and disposal. Work shall proceed in accordance with the recommendations of the Hygienist.

METHOD OF MEASUREMENT

250.09 Environmental Health and Safety Management will not be measured, but will be paid for on a lump sum basis. This will include all work, materials, and hourly time charges by the HSO and other personnel required to accomplish the following:

- (1) Preparation, submittal and briefing of the initial HASP.
- (2) Preparation and submittal of the Waste Management Plan.
 - (i) Preparation and Submittal of the Dewatering Plan.
 - (ii) Preparation and Submittal of the Remediation Plan.
- (3) Procedures and equipment specified in subsections 250.03 - 250.07.
- (4) PPE (levels C and D) for Contractor's personnel for any contamination identified in the preconstruction investigations.
- (5) Preparation and submittal of the final site report.

The quantity to be measured for Health and Safety Officer will be the total number of hours that the Health and Safety Officer is actually used, as authorized, for the following work:

- (1) Field monitoring necessary to ensure the safety of workers on the site.
- (2) Hours in excess of the items listed under Environmental Health and Safety Management.
- (3) Hours that are necessary due to unforeseen site conditions.
- (4) Hours of additional consultation or field work that is requested by the Engineer.

Equipment specified in subsection 250.03(a), preparation and submittal of the daily HSO diary, travel to and from the project site, and PPE (Levels C and D) required for use by the HSO will not be measured and paid for separately, but shall be included in the hourly cost of the HSO.

The quantity to be measured for Monitoring Technician will be the total number of hours that Monitoring Technician is actually used as authorized. Equipment specified in subsection 250.03(b), supervision of the MT, preparation and submittal of the daily monitoring diary, travel to and from the project site, and PPE required for use by the MT (Levels C & D) will not be measured and paid for separately, but shall be included in the hourly cost of the MT.

Solid stockpiled materials will be measured by the cubic yard computed from cross sections by the average end area or other acceptable method. Disposal of solid waste and solid hazardous waste materials will be measured by the cubic yard in the disposal container.

Materials Sampling and Delivery will be measured by the actual number of samples collected, containerized, and transported to the testing facility indicated in the Contract.

Additional environmental health and safety management work required and authorized by the Engineer, but not included in the items listed above, will be considered extra work to be paid for in accordance with subsection 109.04, unless such work is caused by the Contractor's action.

BASIS OF PAYMENT

250.10 Partial payment for Environmental Health and Safety Management, as determined by the Engineer, will be made as the work progresses. The Contractor shall submit a schedule of environmental related Health and Safety Management work before the first partial payment is made. The schedule shall indicate the environmental related Health and Safety Management time for each work item that requires Contractor environmental related Health and Safety Management effort and the total time for the project.

The accepted quantity for Health and Safety Officer will be the number of hours actually used and approved for payment by the Engineer and will be paid for at the contract unit price.

The accepted quantity for Monitoring Technician will be the number of hours of onsite monitoring as approved by the Engineer and will be paid at the Contract unit price.

Environmental Health and Safety Management, Health and Safety Officer and Monitoring Technician bid items shall include vehicles, phone charges, supplies, printing, postage, office support, and all other miscellaneous costs associated with the work.

Payment for Groundwater Handling (Containerization & Analysis) will be made in accordance with subsection 109.04. Payment for Soil Handling (Stockpile) will be made at the contract unit price for all excavated material required to be stockpiled for analysis. The contract unit price will be full compensation for furnishing all materials, labor, equipment and incidentals necessary to complete this work, and all handling of the material prior to disposal. This includes haul, stockpile, and security. Payment for this work will be in addition to any payment made under other bid items for excavation, embankment, or backfill on the project; or waste disposal of this material.

Payment for Solid Waste Disposal and Solid Hazardous Waste Disposal will be made at the appropriate contract unit price for the disposal of material determined to be either solid waste or solid hazardous waste. The contract unit prices will be full compensation for furnishing all materials, labor, equipment, tools, storage containers for transport, containerization of material for up to 60 days, and incidentals necessary to complete this work. This includes all handling of the material, loading for disposal, unloading for disposal, and borrow material

required for replacement of excavated material disposed of offsite. It does not include stockpiling or containerization required for analysis which is included in the item Materials Handling (Stockpile & Containerization) paid for as described above. Payment for waste disposal fees and transport of hazardous waste will be made as shown below. Payment for this work will be in addition to any payment made under other bid items for excavation, embankment, backfill, or material handling (stockpile & containerization) on the project.

- (1) Solid Waste. Transport costs to the disposal facility and disposal fees will be included in the contract unit price for this work.
- (2) Solid Hazardous Waste. Transport costs, disposal fees, and treatment costs will be paid for by planned force account in accordance with subsection 109.04.
- (3) Liquid Hazardous Waste. Transport costs, disposal fees, and treatment costs will be paid for by planned force account in accordance with subsection 109.04.

The cost of shoring required to limit the removal of contaminated materials to the specified limits shall be included in the contract unit prices for any excavation to be performed. Such shoring ordered by the Engineer in areas other than the specified areas of known or potential contamination, as shown on the plans, will be paid for in accordance with subsection 109.04.

Payment for Materials Sampling and Delivery will be made at the contract unit price for each material sample collected, containerized and transported to the laboratory testing facility as designated in the Contract. The contract unit price will be full compensation for furnishing all materials, labor, equipment, tools and incidentals necessary to complete this work including required sampling kits, containers, sample splits, and quality control samples.

The Contractor shall be responsible for damage caused by Contractor negligence to the environment, persons, or property. Expenditures associated with actions of the Contractor shall be borne by the Contractor at no cost to the project.

Contaminated groundwater containerized, treated, or disposed under the requirements of this specification will be paid for by planned force account in accordance with subsection 109.04.

The accepted quantities will be paid for at the contract unit price for each of the pay items listed below that appear in the bid schedule.

Pay Item	Pay Unit
Environmental Health and Safety Management	Lump Sum
Health and Safety Officer	Hour
Monitoring Technician	Hour
Materials Sampling and Delivery	Each
Materials Handling (Stockpile)	Cubic Yard
Solid Waste Disposal	Cubic Yard

**SECTION 506
RIPRAP**

DESCRIPTION

506.01 This work consists of the construction of riprap in accordance with these specifications and in conformity with the lines and grades shown on the plans or established.

MATERIALS

506.02 Riprap shall consist of hard, dense, durable stone, angular in shape and resistant to weathering. Rounded stone or boulders shall not be used as riprap material. The stone shall have a specific gravity of at least 2.5. Each piece shall have its greatest dimension not greater than three times its least dimension.

Material used for riprap may be approved by the Engineer if, by visual inspection, the rock is determined to be sound and durable. The Engineer may require the Contractor to furnish laboratory results if, in the Engineer's opinion, the material is marginal or unacceptable. At the request of the Engineer, the Contractor shall furnish laboratory test results indicating that the material meets the requirements for abrasion resistance or compressive strength as indicated in Table 506-1.

Table 506-1

Test Description	Test Method	Specification Requirement
Abrasion Resistance by Los Angeles Machine	ASTM C 535	50% Loss, max.
Unconfined Compressive Strength of Drilled Core Specimen	AASHTO T 24	2500 psi, min.

Riprap shall conform to the gradation requirements given in Table 506-2.

Table 506-2

Pay Item		Percent of Material Smaller Than Typical Stone ²	Typical Stone Dimensions ³ (Inches)	Typical Stone Weight ⁴ (Pounds)
	Stone Size d50 ¹ (Inches)			
Riprap	6	70-100	12	85
		50-70	9	35
		35-50	6	10
		2-10	2	0.4
Riprap	9	70-100	15	160
		50-70	12	85
		35-50	9	35
		2-10	3	1.3
Riprap	12	70-100	21	440
		50-70	18	275
		35-50	12	85
		2-10	4	3
Riprap	18	100	30	1280
		50-70	24	650
		35-50	18	275
		2-10	6	10
Riprap	24	100	42	3500
		50-70	33	1700
		35-50	24	650
		2-10	9	35

¹d50 = nominal stone size
²based on typical rock mass
³equivalent spherical diameter
⁴based on a specific gravity = 2.5

Nominal stone size and total thickness of the riprap shall be as shown on the plans.

Control of gradation will be by visual inspection. The Contractor shall provide two samples of rock at least 5 tons each, meeting the gradation specified. One sample shall be provided at the construction site and may be a part of the finished riprap covering. The other sample shall be provided at the quarry.

These samples will be used as a reference for judging the gradation of the riprap supplied. When it is determined necessary, conformance of the gradation will be verified by dumping and checking the gradation of two random truck loads of stone. Mechanical equipment, a sorting site, and labor needed to assist in checking gradation shall be provided at the Contractor's expense.

CONSTRUCTION REQUIREMENTS

506.03 Stones with typical stone dimensions that are equal to d50 and larger shall be placed at the top surface with faces and shapes matched to minimize voids and form as smooth a surface as practical. Dumping and backhoe placement alone is not sufficient to ensure a properly interlocked system. The material may be machine-placed and then arranged as necessary by use of an excavator with a multi-prong grappling device or by hand to interlock and form a substantial bond.

Excavation for toe or cut-off walls shall be made to the neat lines of the wall. Allowance will not be made for work outside the neat lines.

METHOD OF MEASUREMENT

506.04 Riprap of the sizes specified in the Contract will be measured by the ton or by the cubic yard. Cubic yards will be by the method of average end areas based on dimensions shown on the plans or ordered.

BASIS OF PAYMENT

506.05 The accepted quantities of riprap will be paid for at the contract unit price per cubic yard or per ton.

Payment will be made under:

Pay Item	Pay Unit
Riprap (___ inch)	Cubic Yard or Ton

Structure excavation will be measured and paid for in accordance with Section 206.

RIPRAP (GABIONS) AND SLOPE MATTRESS

DESCRIPTION

506.06 This work consists of the construction of riprap in wire mesh gabions and in wire mesh slope mattresses in accordance with these specifications and in conformity with the lines and grades shown on the plans or established.

MATERIALS

506.07 The wire, wire mesh, cages, anchor stakes and riprap shall conform to subsection 712.09.

CONSTRUCTION REQUIREMENTS

506.08 Gabions and Slope Mattresses. Gabions and slope mattresses shall be placed to conform to the plan details. Riprap material shall be placed in close contact in the unit so that maximum fill is obtained. The units may be filled by machine with sufficient hand work to accomplish requirements of this specification.

Where the length of the unit exceeds its horizontal width the gabion is to be equally divided by diaphragms, of the same mesh and gauge as the body, into cells whose length does not exceed the horizontal width. The unit shall be furnished with the necessary diaphragms secured in proper position on the base section in such a manner that no additional tying at this juncture will be necessary.

- (a) *Gabions.* All perimeter edges of gabions are to be securely selvedged or bound so that the joints formed by tying the selvedges have approximately the same strength as the body of the mesh.

The gabion bed shall be excavated to the width, line, and grade as staked by the Engineer. The gabions shall be founded on this bed and laid to the lines and dimensions required.

Excavation for toe or cut-off walls shall be made to the neat lines of the wall.

All gabion units shall be tied together each to its neighbor along all contacting edges in order to form a continuous connecting structure.

- (b) *Slope Mattresses.* Slope mattresses shall be filled with angular or fractured stone. Rounded boulders will not be permitted. Before the mattress units are filled, the longitudinal and lateral edge surfaces of adjoining units shall be tightly connected by means of wire ties placed every 4 inches or by a spiral tie having a complete loop every 4 inches. The lid edges of each unit shall be connected in a similar manner to adjacent units. The slope mattress shall be anchored as shown on the plans.

The Contractor shall determine whether the holes for the soil anchor stakes are to be drilled or whether the stakes may be driven. Care shall be taken to avoid drilling holes to a greater depth than is necessary to place the top of the finished stake slightly above the top of the finished mattress.

The Contractor will be allowed to assemble, partially fill, and tie together mattress-units on the subgrade provided they can be placed on the slope without abrading the zinc coating on the wire mattress or permanently distorting the shape of the mattress in transporting and installing the units on the slope. All prefabrication procedures shall be subject to approval.

METHOD OF MEASUREMENT

506.09 The quantity to be measured under this item will be the number of cubic yards of riprap required to fill the gabions and slope mattresses in accordance with the dimensions shown on the plans, or ordered.

BASIS OF PAYMENT

506.10 The accepted quantity measured as provided above will be paid for at the contract unit price per cubic yard for “Riprap (Gabions)” or “Slope Mattress” as the case may be.

506.10

Payment will be made under:

Pay Item	Pay Unit
Riprap (Gabions)	Cubic Yard
Slope Mattress	Cubic Yard

Structure excavation and structure backfill will be measured and paid for in accordance with Section 206.

SECTION 603 CULVERTS AND SEWERS

DESCRIPTION

603.01 This work consists of the construction of culverts (cross drains), side drains, storm drains, and sanitary sewers hereinafter referred to as “conduit”, where a specific pipe material is required, and nestable semicircular pipe for encasement. Work shall be in accordance with these specifications and in conformity with the lines and grades shown on the plans or established.

MATERIALS

603.02 Materials shall meet the requirements shown on the plans and in the following subsections:

Corrugated Steel Pipe and Pipe Arches	707.02
Corrugated Steel Pipe Nestable	707.02
Corrugated Aluminum Pipe	707.06
Reinforced Concrete Pipe	706.02
Nonreinforced Concrete Pipe	706.01
Pipe Joint Sealing Compounds	705.04
Plastic Pipe	712.13
Vitrified Clay Pipe	706.06
Ductile Iron Pipe	707.01
Gaskets	705.03
Resilient Compression Ring Material	705.05
Reinforced Concrete Pipe (Jacked)	706.02

Plastic end sections shall not be used. When plastic pipe is to be installed with end sections, steel end sections conforming to Standard Plan M-603-10 shall be used.

CONSTRUCTION REQUIREMENTS

603.03 General. Pipe shall be protected during handling against impact shocks and free fall.

When new sanitary sewer facilities interfere with the existing flow of sewage, the Contractor shall provide satisfactory bypass facilities at no expense to the Department.

Sanitary sewers and all appurtenances shall be thoroughly cleaned before final acceptance of this work.

603.04 Excavation. Trenches shall be excavated in accordance with the requirements of Section 206 to a width sufficient to allow for proper jointing of the

conduit and thorough compaction of the bedding and backfill material under and around the conduit.

The completed trench bottom shall be firm for its full length and width. The trench for cross drains shall have a minimum longitudinal camber of 1 percent of the length of the pipe. Camber may be increased to suit height of fill and supporting soil.

When conduits are to be installed in new embankments, the embankment shall first be constructed to the required height of at least 0.3 times the outside diameter or raise of the conduit, and for a distance each side of the conduit location of at least 5 times the diameter or span of the conduit, after which the trench shall be excavated and the conduit installed.

Excavation shall be by open cut from the surface, except when pipe jacking is specified or directed in writing by the Engineer.

When pipe is to be jacked, trenching will not be permitted. Pipe must be jacked without disrupting traffic. Methods of installing pipe other than by jacking may be used only with written approval from the Engineer. Methods that may cause damage to the embankment or roadway area will not be approved. Damage to the pipe or installation area caused by jacking operations shall be repaired or replaced at the Contractor's expense. The area around the outer surface of the pipe shall be thoroughly grouted. The grout mixture shall consist of one part portland cement and three parts of fine aggregate by volume, or it may be determined by prior documented experience with similar materials, equipment, and field conditions. The grout shall be thoroughly mixed with the minimum quantity of water needed to obtain the proper consistency for the existing soil conditions.

603.05 Bedding for Concrete or Clay Conduit. Bedding shall be prepared in accordance with details as shown on the plans. The bed shall consist of a layer of loose structure backfill at least 3 inches in thickness. Recesses shall be made to accommodate the bell of bell-and-spigot pipe. Adjustments to line and grade shall be made by scraping or filling under the body of the conduit. Wedging or blocking the bell will not be permitted.

603.06 Placing Conduit. The conduit laying shall begin at the downstream end of the conduit line. The lower segment of the conduit shall be in contact with the prepared bedding throughout its full length. Bell or groove ends of concrete or clay conduits and outside circumferential laps of metal or plastic conduits shall be placed facing upstream.

Paved or partially lined conduit shall be placed so that the longitudinal center line of the paved segment coincides with the flow line.

Elliptical shaped pipe and circular pipe with elliptical reinforcement shall have the top clearly marked with paint or with imprinted letters and with lifting eye holes in which laying pins can be used. Holes shall be finished smooth with grout or with plugs. Conduits shall be placed with the vertical axis within five degrees of a vertical plane through the longitudinal axis of the conduit.

603.07 Joining Conduit.

Joint systems for siphons, irrigation systems, and storm drains shall be watertight.

- (a) *Concrete or Clay Conduit.* Conduit sections shall be joined in such manner that the ends are fully entered and the inner surfaces are reasonably flush and even.

At locations where rubber gaskets are specified in the Contract for conduits used for storm drains and cross culverts, rubber gaskets conforming to subsection 705.03 shall be used. At locations where the type of joint is not otherwise specified in the Contract for conduit used for storm drains and cross culverts, joints shall be made with joint sealing compound. Primer shall be furnished when recommended by the manufacturer of the joint sealing compound. Primer shall conform to and shall be applied in accordance with the manufacturer's recommendations to both surfaces of the conduit sections being joined, for the full circumference. Sealing compound shall be applied according to the manufacturer's recommendations. When a specific type of sealing compound is desired, it shall be as shown in the Contract.

Rubber gaskets conforming to subsection 705.03 shall be used for concrete pipe sanitary sewer joints.

Resilient pressure ring material conforming to subsection 705.05 shall be used for clay pipe sewer joints.

- (b) *Metal Conduit.* Corrugated metal pipe sections shall be placed and aligned to within $\frac{3}{4}$ inch of the adjacent section and shall be firmly joined with either one-piece or two-piece coupling bands. Pipe with helical corrugations shall be joined with the corrugations matched across the joints and with all corrugations of the pipe completely engaged by the corrugations or dimples of the coupling band.

Where existing corrugated metal pipe culverts are to be extended, damaged ends shall be cut off or repaired in an approved manner. All ends of pipes requiring extensions shall be cleaned within the area necessary for proper installation of connecting bands.

Arch culverts shall be extended with pipe having a compatible arch shape.

When special joint treatment is called for on the plans to prevent infiltration or exfiltration, the joints shall be made using a sealing compound conforming to subsection 705.04, with the connecting band.

- (c) *Plastic Conduit.* Couplings shall be as recommended by the conduit manufacturer. Watertight joint systems for plastic pipe shall conform to subsection 705.02.

603.08 Elongation. Where required by the plans, round metal and plastic conduit shall be preformed to an elliptical shape by elongating the vertical axis 5 percent.

603.09 Backfilling. After the conduit or section of conduit is placed, it shall be inspected before any backfill is placed. Reinforced concrete pipe (RCP) shall be visually inspected in accordance with AASHTO LRFD Bridge Construction

Specifications, Section 27.6. Conduit found to be damaged shall be replaced, and conduit found to be out of alignment or unduly settled shall be taken up and relaid. The trench shall then be backfilled with material in accordance with Section 206.

Sanitary sewer lines, when completed, shall be tested for water-tightness before any backfill is placed. The installation shall not show infiltration or exfiltration in excess of 0.6 gallon per inch of internal pipe diameter per 100 feet of sewer line per hour when tested at 10 psi by hydraulic means. Testing of joints shall be performed by the Contractor in accordance with approved methods. Should any section of the sewer line fail to meet the test requirements, it shall be corrected at the Contractor's expense.

Special care shall be taken when backfilling around conduit to bring the backfill materials up on both sides of the conduit, evenly and simultaneously. Protection of conduits during construction shall be the Contractor's responsibility. Damage to the conduit due to Contractor's operations shall be repaired or replaced at the Contractor's expense.

Trenches in existing streets, except streets which are to be closed or abandoned, shall be resurfaced as soon as practicable with the type and thickness of bases and pavement shown in the Contract or as designated.

After culvert pipe is backfilled and earthwork over the pipe is complete to the top of the subgrade, the pipe deflection shall be measured in the presence of the Engineer. The maximum allowable deflection shall be 5 percent. Deflection is a reduction in the inside diameter of the pipe measured in any direction. Measurement shall be made using a mandrel, laser profile, or other method approved by the Engineer. Measurement shall be made 30 days or more following the pipe installation. Pipe having any deflections in excess of 5 percent at any location within the pipe shall be removed and reinstalled. Pipe that is permanently deformed or damaged in any way shall be replaced. Replaced pipe shall be retested 30 days or more after the installation in accordance with the method described above.

603.10 Deflection Testing of Metal and Plastic Pipe. After a metal or plastic pipe is backfilled and earthwork over the pipe is complete to the top of the subgrade, the pipe deflection shall be measured in the presence of the Engineer. The maximum allowable deflection shall be 5 percent. Deflection is a reduction in the nominal diameter of the pipe measured in any direction. Measurement shall be made using a mandrel, laser profile, or other method approved by the Engineer. Measurement shall be made 30 days or more following the pipe installation. Pipe having any deflections in excess of 5 percent at any location within the pipe shall be removed and reinstalled at the Contractor's expense. Pipe that is permanently deformed or damaged in any way shall be replaced at the Contractor's expense. Replaced pipe shall be retested 30 days or more after the installation in accordance with the method described above.

603.11 Repair of Damaged Culvert. Coating on corrugated steel pipe and pipe arches, and corrugated steel pipe nestable shall be repaired in accordance with the provisions of subsection 707.09. Damaged pipe shall not be repaired. The Engineer

will determine when the pipe is either acceptable or unacceptable in accordance with the provisions of subsection 105.03. Unacceptable pipe shall be removed and replaced.

METHOD OF MEASUREMENT

603.12 Conduit used for culverts and storm drains of the different types and sizes and corrugated steel pipe nestable will not be measured but will be the net length of pipe called for on the plans, except when field changes are ordered or when there are errors on the plans. In case of exceptions, the quantity to be measured shall be the actual net length of conduit measured along the bottom centerline. Extra length of conduit due to joint creep will not be measured and paid for. Corrugated steel pipe nestable used for encasement will be measured as complete circular pipe.

Jacked pipe will be measured by the linear foot complete in place and accepted. Structure excavation, structure backfill, grout materials, and grouting operation for jacked pipe will not be measured and paid for separately but shall be included in the work.

End sections will be measured by the number of units installed.

The size designation of metal pipe arch and metal pipe arch end section shall refer to the diameter of round pipe normally used to fabricate the pipe arch or the pipe portion of the end section.

Relaid pipe will be measured and paid for in accordance with Section 210.

BASIS OF PAYMENT

603.13 The accepted quantities will be paid for at the contract unit price for each of the pay items listed below that appear in the bid schedule. Except as otherwise indicated on the plans or in the special provisions, all joints, elbows, concrete collars, connecting bands and other connecting devices will not be paid for separately but shall be included in the work.

Payment will be made under:

Pay Item	Pay Unit
___ Inch Corrugated Steel Pipe	Linear Foot
___ Inch Corrugated Steel Pipe Nestable	Linear Foot
___ Inch Steel End Section	Each
___ Inch Equiv. Corrugated Steel Pipe Arch	Linear Foot
___ Inch Equiv. Arch Steel End Section	Each
___ Inch Corrugated Aluminum Pipe	Linear Foot
___ Inch Aluminum End Section	Each
___ Inch Equiv. Corrugated Aluminum Pipe Arch	Linear Foot
___ Inch Equiv. Arch Aluminum End Section	Each
___ Inch Reinforced Concrete Pipe	Linear Foot
___ Inch Reinforced Concrete End Section	Each

603.13

___ Inch Nonreinforced Concrete Pipe	Linear Foot
___ Inch x ___ Inch Reinforced Concrete Pipe Elliptical	Linear Foot
___ Inch x ___ Inch Reinforced Concrete End Section Elliptical	Each
___ Inch Vitrified Clay Pipe	Linear Foot
___ Inch Cast Iron Pipe	Linear Foot
___ Inch Plastic Pipe	Linear Foot
___ Inch Reinforced Concrete Pipe (Jacked)	Linear Foot
___ Foot x ___ Foot Concrete Box Culvert (Precast)	Linear Foot

Structure excavation and structure backfill will be measured and paid for in accordance with Section 206 except that any void in the structure excavation prism created by the removal of pipe or box culvert will be excluded from measurement and payment of structure excavation.

Repair of damaged coatings will not be paid for separately but shall be included in the cost of the item.

SECTION 604 MANHOLES, INLETS, AND METER VAULTS

DESCRIPTION

604.01 This work consists of the construction of manholes, inlets, and meter vaults in accordance with these specifications, and in conformity with the lines and grades shown on the plans or established.

MATERIALS

604.02 Concrete for these structures shall meet the requirements of Section 601-Structural Concrete.

Other materials shall meet the requirements specified in the following subsections:

Clay or Shale Brick	704.01
Concrete Brick	704.02
Concrete Masonry Blocks	704.03
Frames, Grates, Covers, and Steps	712.06
Grade Ring	712.05
Reinforcing Steel	709.01
Precast Concrete Units	712.05

CONSTRUCTION REQUIREMENTS

604.03 Excavation. Excavation shall be in accordance with the requirements of Section 206.

604.04 Manholes, Inlets, and Meter Vaults.

- (a) *General.* Concrete construction shall conform to the requirements of Section 601. Masonry shall conform to the requirements for the respective type. When specified, the outside face of structures shall be plastered with a ½ inch thick cement-sand mortar coat. Unless otherwise provided, exposed surfaces of concrete and masonry shall be cured as defined in subsection 601.13.

Pipe sections on the inside of manholes or inlets shall be treated as shown on the plans, or as directed, and shall project outside sufficiently for proper connection with next pipe section. Masonry shall fit neatly and tightly around the pipe.

- (b) *Manholes.* Wherever directed by the Engineer, pipes of the proper type and size shall be built into a manhole where future laterals are to be connected. These pipes shall be sealed at their outer ends and an invert shall be built into each manhole for such lateral connections.

When a manhole is located in the pavement area, it shall not be constructed to final grade until the pavement has been completed.

- (c) *Inlets.* Where inlets are placed in existing curbs or gutters, the Contractor shall carefully remove sections of present curb, gutter, or curb and gutter. All damage to sections to remain in place shall be repaired at the Contractor's expense. The top portion of inlets shall be constructed concurrently with the adjacent curb and gutter to insure proper alignment of grades unless otherwise permitted in writing.
- (d) *Meter Vaults.* Meter vaults shall be of sufficient size to properly accommodate the size of the meter installed including regulatory devices or fittings required for the utility supplied. Provisions for grounding, ventilation, drainage or other safety precautions shall be constructed as required. Meter vaults may be cast-in-place or precast and shall conform to the rules and regulations for the utility service supplied in the vault.
- (e) *Brick Masonry.* All bricks shall be thoroughly wetted, before being laid, either by immersion or in a manner satisfactory to the Engineer.

Special care shall be taken to make the face of the brick work smooth. All joints on the interior surface of the manholes and appurtenances shall be carefully struck.

Brick shall not be laid upon a concrete foundation until the concrete has set.

604.05 Backfilling. Unless otherwise directed, all excavations shall be backfilled immediately after the structures are built. Backfilling shall conform with Section 206 and as shown on the plans.

Resurfacing. Excavations in existing streets, except streets which are to be closed or abandoned, shall be resurfaced as soon as practicable with the type and thickness of bases and pavement shown on the plans or as designated.

Cleaning. The structures and all appurtenances shall be thoroughly cleaned before final acceptance of the work.

When the new facilities interfere with the existing flow of sewage, the Contractor shall provide satisfactory bypass facilities at the Contractor's expense.

METHOD OF MEASUREMENT

604.06 Manholes and inlets will be measured by the complete unit including ring and cover or grating and frame.

Manhole ring and cover used separately will be measured by the unit.

Inlet grating and frame used separately will be measured by the unit.

Manhole and inlet depth, "H," will be measured as shown on the plans. Measured depth and pay depth of manholes and inlets shall conform to the following:

Measured Depth	Pay Depth
0.0 to 5.0 feet	5 feet
5.1 to 10.0 feet	10 feet
10.1 to 15.0 feet	15 feet

(continued thus)

Meter vaults will be measured by the complete unit including ring and cover.

Structure excavation and structure backfill for manholes, inlets, and meter vaults will not be measured and paid for separately but shall be included in the work.

BASIS OF PAYMENT

604.07 The accepted quantities will be paid for at the contract unit price for each of the pay items listed below that appear in the bid schedule. Except as otherwise indicated on the plans or in the special provisions, all connecting devices will not be measured and paid for separately but shall be included in the work.

Payment will be made under:

Pay Item	Pay Unit
Meter Vault	Each
Manhole _____ (_____)	Each
Inlet, Type _____ (_____ Foot)	Each
Manhole Ring and Cover	Each
____ Inlet Grating and Frame	Each

SECTION 607 FENCES

DESCRIPTION

607.01 This work consists of the construction of fence and gates, and removal of temporary plastic fence in accordance with these specifications and in conformity with the lines and grades shown on the plans or established.

MATERIALS

607.02 Materials shall meet the requirements specified in the following subsections:

Woven Wire	710.02
Barbed Wire	710.01
Chain Link Fabric	710.03
Fence Posts	710.07
Snow Fence	710.04
Timber for Wood Sound Barrier	710.06

Reinforcing steel shall conform to Section 602.

Concrete shall conform to Section 601.

Foundation concrete for fence posts, braces, anchors and gates shall be Class B. Concrete with lightweight aggregates conforming to ASTM C 330 will be permitted. Field mixed concrete consisting of a minimum of one part cement to six parts of aggregate by volume may be used in lieu of Class B if approved. Pre-packaged concrete may be used if approved.

Fence (Plastic) shall be orange colored material, at least 4 feet in height.

CONSTRUCTION REQUIREMENTS

607.03 The Contractor shall perform such clearing and grubbing as may be necessary to construct the fence to the required grade and alignment.

Right of Way fence shall be constructed approximately 6 inches inside the boundary of the highway right of way shown on the plans or as staked. Anchorages, footings or fence appurtenances shall not extend beyond the limits of the highway right of way without the written consent of the abutting property owner.

At locations where breaks in a run of fencing are required, at intersections with existing fences, or at ditch, canal, or channel crossings, appropriate adjustments in fence alignment and post spacing shall be made to satisfy the requirements for the type of closure indicated or the conditions encountered.

When the plans require that posts, braces or anchors be embedded in concrete, they shall be securely braced to hold the posts in proper position until such time as the concrete has set sufficiently to hold the posts. Unless otherwise permitted, materials shall not be installed on posts, or stress placed on guys and bracing set in concrete until the concrete has set sufficiently to withstand the stress.

The tops of all posts shall be set to the required grade and alignment. Cutting of the tops or bottoms of treated timber posts will be allowed only with the approval of the Engineer. Posts cut in the field shall have the cut surfaces protected with two coats of an approved wood preservative.

Wire or fencing of the size and type required shall be firmly attached to the posts and braces in the manner indicated. All wire shall be stretched taut and be installed to the required spacing.

Wood sound barrier fence shall be constructed according to the details shown on the plans. All fence boards shall be tightly butted to minimize cracks.

Fence (Plastic) shall be placed as shown on the plans or as directed to define the limits of the work area beyond which no access is allowed to the surrounding wetlands or vegetation to be protected.

METHOD OF MEASUREMENT

607.04 Fence will be measured by the linear foot. Measurement will be along the base of the fence from outside to outside of end posts for each continuous run of fence including length of barbed wire gates, but excluding the length of driveway gates and walk gates.

Driveway gates and walk gates will be measured as complete units of the size and type specified. Gates shall be the same type and height as the adjacent fence unless otherwise designated.

End posts, corner posts and line brace posts required for chain link fence, barbed wire and combination wire fence will be measured by the actual number used.

End posts, corner posts and line brace posts for snow fence or barrier fence will not be measured and paid for separately but shall be included in the work.

Line posts required for reset fence will be measured by the actual number used.

Line posts required for new fence will not be measured separately, but shall be included in the contract unit price for new fence.

End Posts Special, Corner Posts Special, and Line Brace Posts Special required for Fence (Deer) will be measured by the actual number used.

Fence Wood (Sound Barrier) will be measured by the linear foot.

Fence (Plastic) will be measured by the linear foot. Posts will not be measured and paid for separately, but shall be included in the work.

Measurement will be along the base of the fence from outside to outside of end posts for each continuous run of fence, and shall include all wood, hardware, concrete, reinforcing steel, excavation and backfill, and all other incidentals to the erection of the fence.

BASIS OF PAYMENT

607.05 The accepted quantities of fence will be paid for at the contract unit price for each of the pay items listed below that appear in the bid schedule.

Payment will be made under:

Pay Item	Pay Unit
Fence (____) (____ Inch)	Linear Foot
(____ Foot) Gate (____)	Each
Line Post	Each
End Post	Each
Corner and Line Brace Post	Each
End Post (Chain Link)	Each
Corner and Line Brace Post (Chain Link)	Each
End Post Special	Each
Corner and Line Brace Post Special	Each
Deer Gate	Each
Fence Wood (Sound Barrier) (____ Inch)	Linear Foot
Fence (Plastic)	Linear Foot

Payment for Fence (Plastic) shall be full compensation for furnishing, erecting, maintaining, removing, and disposing of all materials required. Fence (Plastic) shall remain the property of the Contractor.

SECTION 705

JOINT, WATERPROOFING, AND BEARING MATERIAL

705.01 Joint Fillers.

- (a) *Joint Sealant with Backer Rod.* The joint sealant material shall be a silicone that is on the Department's Approved Products List. The silicone materials shall be stored and applied in accordance with manufacturer's recommendations, but they shall not be exposed to ambient temperatures in excess of 125 °F or stored in direct sunlight. The backer rod placed prior to joint sealant shall be constructed of closed cell polyethylene strand as approved.
- (b) *Preformed Joint Fillers.* Preformed fillers for joints shall conform to the requirements of AASHTO M 213 and shall be punched to admit the dowels where called for on the plans. The filler for each joint shall be furnished in a single piece for the full depth and thickness required for the joint unless otherwise authorized by the Engineer. When the use of more than one piece is authorized for a joint, the abutting ends shall be fastened securely, and held accurately to shape, by stapling or other positive fastening satisfactory to the Engineer.

705.02 Watertight Joint Systems. Watertight joint systems for plastic pipe shall conform to the requirements of ASTM D 3212.

705.03 Gaskets. Rubber gasketed joints shall conform to the requirements of ASTM C443 and shall be flexible and able to withstand expansion, contraction, and settlement.

All rubber gaskets shall be stored in as cool a place as practicable, preferably at 70 °F or less. Rubber gaskets shall not be exposed to the direct rays of the sun for more than 72 hours.

Rubber gaskets, of the type requiring lubrication, shall be lubricated with the lubricant recommended and supplied by the manufacturer of the pipe.

705.04 Pipe Joint Sealing Compounds. Joint sealing compounds for concrete pipe shall conform to the requirements of AASHTO M 198.

Joint sealants for metal pipe shall conform to the pipe manufacturer's recommendations.

705.05 Compression Ring. Compression ring jointing connections for clay pipe, made of resilient material, shall conform to the requirements of ASTM C425.

705.06 Bearing Materials

Table 705-1
POLYISOPRENE (NATURAL RUBBER) ELASTOMER

Specimen Properties	ASTM Test Procedure	Requirements		
		50 Duro	60 Duro	70 Duro
Physical Properties				
Hardness	D2240	50 ± 5	60 ± 5	70 ± 5
Tensile Strength, MPa Minimum (psi).	D412	15.5 (2250)	15.5 (2250)	15.5 (2250)
Ultimate Elongation, % Minimum	D412	450	400	300
Heat Resistance, 70 Hr./70 °C (158 °F)				
Change in Durometer Hardness, Maximum Points		+10	+10	+10
Change in Tensile Strength, % Maximum	D573	-25	-25	-25
Change in Ultimate Elongation, % Maximum	D573	-25	-25	-25
Compression Set				
% Maximum, 22 Hr./70 °C (158 °F)	D395 Method B	25	25	25
Ozone Resistance, 20% Strain				
25 ppm Ozone in Air by Volume 38 ± 1 °C (100 ± 2 °F)/48 Hr. Mounting Procedure ASTM D518, Procedure A	D1149	No Cracks	No Cracks	No Cracks
Adhesion				
Bond Made during Vulcanization, N per mm (Lb. per Inch)	D429, B	7 (40)	7 (40)	7 (40)
Low Temperature Brittleness:				
Grade 3 at -40 °C (-40 °F) Grade 4 at -48 °C (-55 °F) Grade 5 at -57 °C (-70 °F)	D746 Procedure B	No Failure	No Failure	No Failure
Instantaneous Thermal Stiffening:				
Grade 3 at -40 °C (-40 °F) Grade 4 at -46 °C (-50 °F) Grade 5 at -54 °C (-65 °F)	D1043	1 3	1 3	1 3
Low Temperature Crystallization:				
Grade 3, 14 Days at -26 °C (-15 °F) Grade 4, 21 Days at -37 °C (-35 °F) Grade 5, 28 Days at -37 °C (-35 °F)	D4014 Quad Shear Test as described in Annex A	2 3	2 3	2 3
¹ Stiffness at test temperature shall not exceed 4 times the stiffness measured at 23 °C (73 °F). ² Stiffness at test time and temperature shall not exceed 4 times the stiffness measured at 23 °C (73 °F) with no time delay. The stiffness shall be measured with a quad shear test rig in an enclosed freezer unit. The test specimens shall be taken from a randomly selected bearing. A ± 25° strain cycle shall be used and a complete cycle of strain shall be applied with a period of 100 seconds. The first ¼ cycle of strain shall be discarded and the stiffness shall be determined by the slope of the force deflection curve for the next ½ cycle of loading. ³ ASTM D1043 refers to the “Modulus of Rigidity” while ASTM D4014 refers to the “Shear Modulus Stiffness”. The word “stiffness” is used to describe both terms.				

Table 705-2
CHLOROPRENE (NEOPRENE) ELASTOMER

Specimen Properties	ASTM Test Procedure	Requirements		
		50 Duro	60 Duro	70 Duro
Physical Properties				
Hardness	D 240	50 ± 5	60 ± 5	70 ± 5
Tensile Strength, MPa Minimum (psi).	D412	17.2 (2500)	17.2 (2500)	17.2 (2500)
Ultimate Elongation, % Minimum	D412	400	350	300
Heat Resistance, 70 Hr./ 70 °C (158 °F)				
Change in Durometer Hardness, Maximum Points		+15	+15	+15
Change in Tensile Strength, % Maximum	D573	-15	-15	-15
Change in Ultimate Elongation, % Maximum	D573	-40	-40	-40
Compression Set				
% Maximum, 22 Hr./100 °C (212 °F)	D395 Method B	35	35	35
Ozone Resistance, 20% Strain				
100 ppm Ozone in Air by Volume 38 ± 1 °C (100 ± 2 °F)/ 100 Hr. Mounting Procedure ASTM D518, Procedure A	D1149	No Cracks	No Cracks	No Cracks
Adhesion				
Bond Made during Vulcanization, N per mm (Lb. per Inch)	D429, B	7 (40)	7 (40)	7 (40)
Low Temperature Brittleness:				
Grade 3 at -40 °C (-40 °F) Grade 4 at -48 °C (-55 °F) Grade 5 at -57 °C (-70 °F)	D746 Procedure B	No Failure	No Failure	No Failure
Instantaneous Thermal Stiffening:				
Grade 3 at -40 °C (-40 °F) Grade 4 at -46 °C (-50 °F) Grade 5 at -54 °C (-65 °F)	D1043	1 3	1 3	1 3
Low Temperature Crystallization:				
Grade 3, 14 Days at -26 °C (-15 °F) Grade 4, 21 Days at -37 °C (-35 °F) Grade 5, 28 Days at -37 °C (-35 °F)	D4014 Quad Shear Test as described in Annex A	2 3	2 3	2 3
¹ Stiffness at test temperature shall not exceed 4 times the stiffness measured at 23 °C (73 °F). ² Stiffness at test time and temperature shall not exceed 4 times the stiffness measured at 23 °C (73 °F) with no time delay. The stiffness shall be measured with a quad shear test rig in an enclosed freezer unit. The test specimens shall be taken from a randomly selected bearing. A ± 25° strain cycle shall be used and a complete cycle of strain shall be applied with a period of 100 seconds. The first ¾ cycle of strain shall be discarded and the stiffness shall be determined by the slope of the force deflection curve for the next ½ cycle of loading. ³ ASTM D 1043 refers to the “Modulus of Rigidity” while ASTM D 4014 refers to the “Shear Modulus Stiffness”. The word “stiffness” is used to describe both terms.				

- (a) *Elastomeric Bearing Pads*. Laminates shall be rolled mild steel sheets conforming to AASHTO M 270 Grade 36 unless otherwise specified.

A Durometer hardness of 60 shall be used unless otherwise shown on the plans.

The elastomer portion of the elastomeric compound shall be 100 percent virgin natural polyisoprene (natural rubber) or 100 percent virgin chloroprene (neoprene), and shall be at least 60 percent by volume of the total compound.

- (b) *Sheet Lead*. Sheet lead shall conform to the requirements of ASTM B29 for common desilverized lead.
- (c) *Polytetrafluoroethylene (PTFE) Sheets*. PTFE resin shall be virgin material conforming to the requirements of ASTM D 4894 or D4895. The specific gravity shall be 2.13 to 2.19 and the melting point shall be $623\text{ }^{\circ}\text{F} \pm 2^{\circ}\text{F}$.

Filler material shall be milled glass fibers, carbon, or other approved inert filler materials.

Finished unfilled PTFE sheet shall be made from PTFE resin and shall conform to the following requirements:

Tensile strength (min.) ASTM D4894 or D4895 2800 psi

Elongation (min.) ASTM D4894 or D4895 200 percent

Filled PTFE sheet shall be made from PTFE resin uniformly blended with inert filler material. Finished filled PTFE sheet containing glass fiber or carbon shall conform to the following requirements:

Mechanical	ASTM Method	15% Glass Fiber	25% Carbon
Tensile Strength (min.)	D4894 or D4895	2000 psi	1300 psi
Elongation (min.)	D4894 or D4895	150%	75%
Physical	ASTM Method	15% Glass Fiber	25% Carbon
Specific Gravity (min.)	D4894 or D4895	2.20	2.10
Melting Point	D4894 or D4895	$621\text{ }^{\circ}\text{F} \pm 18\text{ }^{\circ}\text{F}$	$621\text{ }^{\circ}\text{F} \pm 18\text{ }^{\circ}\text{F}$

The maximum coefficient of friction for the PTFE shall be as follows:

Bearing Pressure	500 psi	2000 psi	3000 psi
Unfilled PTFE	0.08	0.06	0.04
Filled PTFE	0.12	0.10	0.08

The average bearing pressure on the PTFE sliding surface due to all loads shall not exceed:

Type II Bearing Device Unfilled and Filled PTFE	2000 psi
Type III Bearing Device Filled PTFE	3500 psi
Unfilled PTFE (Recessed)	3500 psi
Unfilled PTFE (Not Recessed)	2000 psi

The edge load pressure due to all loads and rotations shall not exceed:

Unfilled and filled PTFE (Type II and III Bearing Device) 5000 psi

- (d) *Stainless Steel Sheets.* The stainless steel sheet shall be 16 gage minimum thickness and shall conform to ASTM A240, Type 304.
- (e) *Adhesive Material.* Adhesive material shall be an epoxy resin meeting the requirements of Federal Specification MMM-A-134, FEP film or approved equal.
- (f) *Certification and Testing.* The Contractor shall furnish a manufacturer's certification that the material proposed for use on the project meets the requirements set forth in the tables above. The Department also reserves the right to test random samples of full size bearings proposed for use on the project. The following values shall be met under laboratory testing of full size bearings.
- (1) Compressive strain of any layer of an elastomeric bearing shall not exceed 7 percent at 800 psi average unit pressure, or at the design dead load plus live load pressure when so shown on the plans.
 - (2) The shear resistance of the bearing shall not exceed 30 psi for 50 durometer, 40 psi for 60 durometer, or 50 psi for 70 durometer, polyisoprene compounds, nor 50 psi for 50 durometer, 75 psi for 60 durometer, or 110 psi for 70 durometer, chloroprene compounds. Shear resistance shall be measured at 25 percent strain of the total effective rubber thickness after an extended four-day ambient temperature of -20 °F.
- Components of nominal hardness between values shown may be used and test requirements interpolated. When test specimens are cut from the finished product a 10 percent variation in "physical properties" will be permitted.
- (g) *Tolerances.* Flash tolerance, finish and appearance shall meet the requirements of the latest edition of the Rubber Handbook as published by the Rubber Manufacturers Association, Inc., RMA F3 and T.063 for molded bearings and RMA F2 for extruded bearings.

For both plain and laminated bearings, the permissible variation from the dimensions and configuration required by the plans and these specifications shall be as follows:

(1) Overall Vertical Dimensions:	
Average Total Thickness 1¼ inches or less	-0, +1/8 inch
Average Total Thickness over 1¼ inches	-0, +1/4 inch
(2) Overall Horizontal Dimension:	
36 inches and less	-0, +1/4 inch
Over 36 inches	-0, +1/2 inch
(3) Thickness of Individual Layers of:	
Elastomer (Laminated Bearings Only)	±1/8 inch
(4) Variation from a Plane parallel to the Theoretical Surface (as determined by measurements at the edges of the bearings):	
Top	±1/8 inch
Sides	±1/4 inch
Individual Non-Elastic Laminates	±1/8 inch
(5) Position of Exposed Connection Members:	
	±1/8 inch
(6) Edge Cover of Embedded Laminates or Connection Members:	
	-0, +1/8 inch
(7) Size of Holes, Slots or Inserts:	
	±1/8 inch
(8) Position of Holes, Slots or Inserts:	
	±1/8 inch

705.07 Protective Covering for Bridge Deck Waterproofing Membrane. The protective covering shall be composed of one or more layers of felt thoroughly bonded together and saturated with asphalt. Both exposed sides shall be asphalt-coated. The density shall be 55 pounds per 100 square feet. The surfaces shall be coated with suitable mineral matter to prevent the material from sticking to itself.

The covering may be furnished either in rolls or sheets.

The covering shall be free of visible external defects, such as holes, ragged or untrue edges, breaks, cracks, tears, protuberances, and indentations.

The covering furnished in rolls shall not crack nor be so sticky as to cause material damage upon being unrolled at atmospheric temperatures as low as 50 °F.

The covering shall conform to the following requirements when tested in accordance with Colorado Procedure L-2202:

Property Determined	Specification
Width	Min. 35 ½", Max. 60 ½"
Pliability at 25 °C (77 °F)	At least 4 of 5 strips shall not crack when bent 90° over a rounded corner of 13 mm (½") radius.
Behavior on heating to 80 °C (176 °F)	Max. 1.5 percent volatile loss. No flowing, sagging or blistering.
Weight per square foot	0.5 lbs

Protective covering may be conditionally accepted in the field based on visual inspection for appearance, workmanship, and weight per square foot of a representative specimen.

705.08 Prefabricated, Reinforced Membrane and Primer. The membrane shall be a factory laminated sheet composed of either rubberized asphalt, bituminous mastic, or similar compounds reinforced with synthetic or fiberglass fabric. It shall be uniformly manufactured free from blemishes, discontinuities, and other defects. The membrane shall be supplied in rolls, having a minimum width of 30 inches and shall conform to the following requirements:

Property Determined	Test Procedure	Specification
Thickness		70 mils minimum
Pliability	CP L-2203	No cracks

The primer used to bond membrane to the deck and to seal seams and patches shall be a water resistant adhesive compatible with the membrane. The primer shall be of suitable consistency for application by brush, roller, or spray without further dilution.

705.09 Single Component, Hot Applied, Elastomeric Membrane. The membrane shall be capable of being sprayed or spread to a uniform thickness at the application temperature recommended by the manufacturer. After cooling it shall form a tough resilient membrane, well bonded to the concrete surface and shall conform to the requirement of ASTM D 6690 Type 2, except that blocks for the bond test shall be prepared in accordance with CP-L 4101.

The sealant shall be listed in CDOT's Approved Products List prior to use.

705.10 Waterstop. Neoprene waterstop shall be made of suitable synthetic rubber. Neoprene waterstop shall conform to the applicable requirements designated in the latest edition of the Corp of Engineers Specifications for Rubber Waterstops CRD-C513.

Plastic waterstop shall be made of polyvinyl chloride (PVC) plastic. Plastic waterstop shall conform to the requirements designated in the latest edition of the Corp of Engineers Specifications for Polyvinyl chloride Waterstops CRD-C572.

SECTION 706 CONCRETE AND CLAY PIPE

706.01 Nonreinforced Concrete Pipe. This pipe shall conform to the requirements of AASHTO M 86 for the specified diameters and strength classes.

Pipe shall be obtained from a manufacturer that is a current plant quality certified member of the American Concrete Pipe Association (ACPA), meeting all current ACPA requirements for this certification.

A copy of the ACPA certification shall be submitted to the Engineer prior to delivery of the pipe.

706.02 Reinforced Concrete Pipe. This pipe shall conform to the requirements of AASHTO M 170 for the specified diameters and strength classes. Unless otherwise specified, pipe wall design and use of elliptical reinforcement in circular pipe are optional. Reinforced concrete pipe being jacked shall be Class V and shall be furnished with grouting nipples spaced not more than 8 feet apart. Joints for this pipe shall come equipped with steel rings and rubber gaskets conforming to ASTM C361.

Elliptical pipe conforming to AASHTO M 207 shall be furnished when required on the plans. Arch pipe conforming to AASHTO M 206 shall be furnished when required on the plans.

Precast reinforced concrete end sections shall have at least one line of reinforcement conforming to the requirements of AASHTO M 170 equivalent to the square inches per linear foot for elliptical reinforcement in circular pipe, Class II, Wall B.

Pipe shall be obtained from a manufacturer that is a current plant quality certified member of the American Concrete Pipe Association (ACPA), meeting all current ACPA requirements for this certification.

A copy of the ACPA certification shall be submitted to the Engineer prior to delivery of the pipe.

706.03 Perforated Concrete Pipe. This pipe shall conform to the requirements of AASHTO M 175 for the specified diameters and strength classes. Unless otherwise specified, perforations shall be Type 1.

Pipe shall be obtained from a manufacturer that is a current plant quality certified member of the American Concrete Pipe Association (ACPA), meeting all current ACPA requirements for this certification.

A copy of the ACPA certification shall be submitted to the Engineer prior to delivery of the pipe.

706.04 Drain Tile. This pipe shall conform to the requirements of AASHTO M 178 or M 179 for the specified material, diameters and quality classes.

706.05 Porous Concrete Pipe. This pipe shall conform to the requirements of AASHTO M 176 for the specified diameters.

Pipe shall be obtained from a manufacturer that is a current plant quality certified member of the American Concrete Pipe Association (ACPA), meeting all current ACPA requirements for this certification.

A copy of the ACPA certification shall be submitted to the Engineer prior to delivery of the pipe.

706.06 Vitrified Clay Pipe. This pipe shall conform to the requirements of AASHTO M 65 for the specified diameter and strength class.

706.07 Coated Concrete Pipe. This pipe may be reinforced or nonreinforced in accordance with the requirements shown on the plans for the designated diameters and strength classes, and in addition, shall be coated with asphalt mastic conforming to the requirements of AASHTO M 243.

Asphalt mastic shall be uniformly applied in two coats by spray or brush to the entire designated surface to be coated, to a total thickness of 50 mils. Asphalt mastic may also be applied by trowel in one coat provided the required thickness is obtained. The first coat shall be dry to touch before the second coat is applied. The second coat shall be dry to touch before any handling or backfilling operations.

The finished coat shall cover the surface to be protected evenly, without running, and without any visible holidays, bubbles, or bare spots.

DIVISION 1
GENERAL REQUIREMENTS

PART 1 – GENERAL

1.1 WORK COVERED BY CONTRACT DOCUMENTS

- A. The Contract generally includes approximately 2000 linear feet of 48" internal diameter RCP (or equivalent) and 54" outside diameter HDPE, with a section requiring bore under I70, new effluent box, removal and abandonment of the existing effluent outfall, and a new diffuser outfall in the Colorado River. Not every detail is shown in the Drawings or described in the Specifications. Minor additional work items shall be included in the Contractors Bid Price and it is expressly agreed that this work will be performed with no claim for additional cost.
- B. The CONTRACTOR is responsible for security on the Project until Substantial Completion of the Project.

1.2 DOCUMENTS

- A. Drawings and Specifications
 - 1. Do not scale Drawings.
 - 2. Take all dimensions and measurements from actual equipment to be furnished. All dimensions and measurements must be verified in the field. Actual locations, distances, and elevations will be governed by actual field conditions. CONTRACTOR shall be responsible for all measurements taken in the field.
 - 3. This Project Manual is prepared using the Construction Specification Institute (CSI) basic concepts and techniques and shall be so interpreted. Each section is divided into three parts wherever applicable in accordance with the guidelines established by the CSI format for construction specifications.

1.3 DELIVERY & RECEIPT OF EQUIPMENT AND MATERIALS

- A. CONTRACTOR is responsible for the delivery, receipt, storage, protection and use of equipment and materials in conjunction with this Project. OWNER will not receive or take any responsibility for equipment and materials delivered to the site.

1.4 NOTICE TO OWNERS AND AGENCIES

- A. Give notification sufficiently in advance to enable affected persons to provide for their needs when necessary.
- B. Contact utilities and other concerned agencies at least 48 hours,

exclusive of weekends and holidays, prior to excavating near underground utilities or pole lines, or performing Work which may affect them.

- C. Names of affected agencies and utilities in the area are listed below for CONTRACTOR's convenience.

UTILITIES

Water:	City of Grand Junction
Sanitary Sewer:	City of Grand Junction
Storm Sewer:	City of Grand Junction
Electric:	Excel Energy
Gas:	Excel Energy
Telephone:	Century Link
Roads:	CDOT/City of Grand Junction

AGENCIES

Fire:	EMERGENCY - 911
Police:	EMERGENCY - 911
Ambulance:	EMERGENCY - 911

PART 2 – PRODUCTS (NOT USED)

PART 3 – EXECUTION (NOT USED)

END OF SECTION

PART 1 – GENERAL

1.1 NEED FOR CONTINUOUS OPERATION

- A. The existing wastewater treatment plant is operated by the OWNER. Throughout the construction period, the facility shall not be interrupted. Any interruption of the operation shall be approved and coordinated by the OWNER.
 - 1. Provide temporary facilities and make temporary modifications as required (and as satisfactory to OWNER) to keep the existing facilities in operation throughout the construction period.
 - 2. It is anticipated that flows from the plant will be able to be shut off for a short duration (less than 12 hours) for final connection to the existing system
- B. CONTRACTOR shall assume the responsibility for maintenance of all access roads as required for completion of the Work including, but not limited to snow plowing, grading, and temporary gravel surfacing.
- C. Construction activities shall not encumber or prevent access, by the OWNER, to the existing facilities and to the project site.
- D. The OWNER will maintain the operation of the existing treatment facilities.
- E. Contractor shall not demolish the existing outfall facilities until acceptance of the diffuser has been obtained from the owner. It is not necessary to perform bypass pumping during this time however it may be necessary to divert effluent to either the existing outfall or new diffuser outfall using stop logs or similar.

1.2 ACCESS

- A. CONTRACTOR shall assume complete responsibility for the maintenance of all access roads as required for completion of the Work including, but not limited, to snow plowing, grading, and temporary gravel surfacing.
- B. Construction activities shall not encumber or prevent access, by the OWNER, to the existing wastewater treatment facility.

1.3 COORDINATION

- A. CONTRACTOR shall be responsible for performing the Work necessary to set up any temporary works generally described by this Specification. The OWNER shall be responsible for operating the existing treatment facilities

during the construction period. CONTRACTOR shall provide advance notice to the OWNER of any construction activities that may affect operation of the treatment facility.

1.4 CONNECTION TO EXISTING FACILITIES

- A. Unless otherwise specified or indicated, CONTRACTOR shall make all necessary connections to existing facilities including structures, drain lines and utilities.
 - 1. Obtain permission from OWNER or the owning utility prior to undertaking connections.
 - 2. Provide at least 72 hours advance notification.
 - 3. Protect facilities from deleterious substances and damage.
- B. Plan connections to existing facilities which are in service thoroughly in advance. All required equipment, materials, and labor shall be on hand prior to undertaking the connections.
- C. The CONTRACTOR is ultimately responsible for locating all underground utilities that may be affected prior to excavating.
- D. Utility Service Outages
 - 1. Any work requiring service outages will be required to be coordinated between the CONTRACTOR and OWNER prior to the outage.

1.5 WORK SEQUENCE

- A. CONTRACTOR is to determine his own sequence of activities, except as required in these Specifications.

PART 2 – PRODUCTS (NOT USED)

PART 3 – EXECUTION (NOT USED)

END OF SECTION

1.1 GENERAL

DESCRIPTION OF CONTRACT BREAKDOWN

The work performed under this Agreement shall be paid for on a Unit Price basis and Lump Sum basis for individual line items at the rates for the respective items on the Bid Schedule. The quantities provided on the Bid Schedule are only estimates of the actual quantities of the work to be performed, and are only included for purposes of making the award and establishing a basis for estimating the probable cost of the Work. The actual amounts of work performed and materials furnished for unit price bid items may differ from the estimated quantities. The basis of payment for work and materials bid as a unit price will be the actual amount of approved work done and materials furnished. The CONTRACTOR agrees that he will make no claim for damages, anticipated profits, or otherwise on account of any difference between the amounts of work actually performed and materials actually furnished and the estimated amount for bid items.

Payment shall be made only for those items included in the Bid Schedule. All costs incurred shall comply with the provisions of these Specifications and shall be included in the unit price bid for the associated items in the Bid Schedule. Except as may be otherwise stipulated; no material, labor or equipment will be furnished by the OWNER. The quantity of work which will be considered for payment is the actual number of units completed in accordance with all relative Specifications. This basis of measurement and payment for each proposal item will be described below. The following provides a general listing of contract bid items along with a brief summary of the work and materials included, but not limited to, in the unit price, time and materials, or lump sum price for each bid item. Refer to the Specifications and Drawings for additional information.

1.2 SCOPE OF WORK

The Total Base Bid price shall cover all Work required by the Contract Documents. All costs in connection with the proper and successful completion of the Work, including furnishing all materials, equipment, supplies, and appurtenances; providing all construction plant, equipment, and tools; performing all necessary labor and supervision to fully complete the Work in accordance with the Drawings and these Specifications and Contract Documents, shall be included in the prices Bid.

1.3 BID ITEM DESCRIPTIONS

1) Clearing and Grubbing

No measurement for payment shall be made for any of the work, materials, and equipment required for clearing and grubbing. The lump sum (LS) bid price shall include all of the CONTRACTOR's costs of whatsoever nature including labor, material, and any incidental work and equipment necessary for clearing, grubbing, removing, and disposing of vegetation and debris within limits of the project footprint and temporary easement. The unit price shall include, but not be limited to all costs for materials, labor, and any other miscellaneous items and work shown or reasonably implied on the Drawings and in the Specifications for this work, and elsewhere in the Contract Documents.

<u>Pay Item</u>	<u>Pay Unit</u>
Clearing and Grubbing	LS

2) Remove and Replace Fence

This unit price per linear foot (LF) item shall be measured for payment along the fence and shall be continuous between fence posts. Removal and replacement shall leave space for a new dual gate at the west side of Persigo Wastewater Treatment Plant to facilitate future access. Removal and replacement on the east side of the plant shall be as needed to remove the existing effluent headwall and piping.

<u>Pay Item</u>	<u>Pay Unit</u>
Remove and Replace Fence	LF

3) Erosion/Sediment Control

Payment shall be made as the work progresses. Payment shall be made based on the actual number of erosion control features installed and inspected. All maintenance of BMP's shall be included in the cost of the installed BMP.

Silt fence, erosion logs, temporary berms, and temporary slope drains, will be measured by the actual number of linear feet that are installed and accepted.

Soil lifts will be measured by the actual number of linear feet (LF) (3' Height) that are installed and accepted

Storm drain inlet protection will be measured by the linear foot (LF) of storm drain inlet protection device installed and accepted.

Sediment trap quantities will be measured by the actual number installed and accepted. (EA)

Removal of trash that is not generated by construction activities will not be measured but is considered incidental to the project (See Special Condition 3.3.20).

Concrete washout structure will be measured by the actual number of structures that are installed and accepted. (EA)

Vehicle tracking pads will be measured by the actual number constructed and accepted. (EA)

Erosion Control Management (ECM) will not be measured. The lump sum (LS) bid price shall include all of the CONTRACTOR's costs of whatsoever nature including labor, material, and any incidental work and equipment necessary for the work. The ECS is required to be on the project performing the duties outlined in CDOT subsection 208.03(c).

Temporary Diversion (Coffer Dam) will be measured by the linear foot (LF) at the centerline of the Coffer Dam installed and accepted.

Temporary Stream Crossing (Persigo) will not be measured. The lump sum (LS) bid price shall include all of the CONTRACTOR's costs of whatsoever nature including labor, material, and any incidental work and equipment necessary to construct the temporary crossing of Persigo Wash. The unit price shall include, but not be limited to all costs for materials, excavation, bedding, backfill and compaction, pipe, reinforcement, protective wraps, removal of all materials, restoration, and any other miscellaneous items and work shown or reasonably implied on the Drawings and in the Specifications for this work, and elsewhere in the Contract Documents.

Seeding, Soil Conditioning, and Mulching (Hydraulic) will be measured by the total acreage (AC) installed and accepted.

Landscape Maintenance will not be measured. The lump sum (LS) bid price shall include all of the CONTRACTOR's costs of whatsoever nature including labor, material, and any incidental work and equipment necessary to maintain and restore the site to natural conditions. The unit price shall include, but not be limited to all costs for materials, excavation, bedding, backfill and compaction, additional seed, protective wraps, removal of all materials, restoration, and any other miscellaneous items and work shown or reasonably implied on the Drawings and in the Specifications for this work, and elsewhere in the Contract Documents for a one (1) year duration.

See Section 01563 and Sheets C101, and C503 to C506, and CDOT Section 208 for additional detail.

<u>Pay Item</u>	<u>Pay Unit</u>
Topsoil	CY
Stockpile Topsoil	CY
Silt Fence	LF
Erosion Log Type 1 (20 Inch)	LF
Temporary Berms	LF
Soil Lifts (3' High)	LF
Storm Drain Inlet Protection (Type 1)	LF
Sediment Trap	EA
Pre-fabricated Concrete Washout Structure	EA
Vehicle Tracking Pad	EA
Erosion Control Management (ECM)	LS
Temporary Diversion (Coffer Dam)	LF
Temporary Stream Crossing (Persigo)	LS
Seeding (Native)	AC
Soil Conditioning	AC
Mulching (Hydraulic)	AC
Landscape Maintenance	LS

4) Riprap (D₅₀ = 9 inches)

This unit price per cubic yard (CY) item shall be measured for payment based on the dimensions provided in the plans as installed. The bid price shall include all of the CONTRACTOR's costs of whatsoever nature including labor, material, and any incidental work and equipment necessary to install and compact the riprap. The unit price shall include, but not be limited to all costs for materials, excavation, bedding and soil retention blanket, backfill and compaction, removal of all materials, restoration, and any other miscellaneous items and work shown or reasonably implied on the Drawings and in the Specifications for this work, and elsewhere in the Contract Documents.

<u>Pay Item</u>	<u>Pay Unit</u>
Riprap (D ₅₀ = 9 inches)	CY

5) Fence Double Gate (6' High) (Chain Link, Barbed Wire Top, Top Rail)

This unit price per linear foot (LF) item shall be measured for payment based on the required 30' opening as shown on the plans. The bid price shall include all of the CONTRACTOR's costs of whatsoever nature including labor, material, and any incidental work and equipment necessary to install the fence gate. The unit price shall include, but not be limited to all costs for materials, labor, and any other miscellaneous items and work shown or reasonably implied on the Drawings and in the Specifications for this work, and elsewhere in the Contract Documents.

<u>Pay Item</u>	<u>Pay Unit</u>
Fence Double Gate	LF

6) Furnish and Install 48" (ID) Reinforced Concrete Pipe (Class III) or Equivalent

This unit price per linear foot (LF) item shall be measured for payment along the horizontal plane from beginning station to ending station for each portion of the pipeline as installed. Pipeline length shall be measured on a continuing line through all manholes.

The work includes but is not limited to locating and protection of the existing above and belowground utilities in and along the pipe length; furnishing, transporting, and installing all pipe and materials; caps, and spacers; adjusting location of existing utilities; excavation including exploratory excavation, trench support, dewatering, constructing the specific bedding, backfill including imported backfill if needed, compaction, groundwater barriers; and other miscellaneous items as required to construct the pipeline; trench support; disposal of excess excavated material and damaged materials; pressure testing the newly installed pipelines; and all other appurtenant work, materials and equipment required to construct a complete operable pipeline in accordance with the Drawings and Specifications.

LF pricing will be paid for up to 110% of pipe length as shown on the drawings. Additional pipe will be negotiated as necessary.

<u>Pay Item</u>	<u>Pay Unit</u>
Furnish and Install 48" RCP (ID) or Equivalent	LF

7) Furnish and Install 54" OD HDPE Pipe

This unit price per linear foot (LF) item shall be measured for payment along the horizontal plane from beginning station to ending station for each portion of the pipeline as installed. Pipeline length shall be measured on a continuing line through all manholes.

The work includes but is not limited to locating and protection of the existing above and belowground utilities in and along the pipe length; furnishing, transporting, and installing all pipe and materials; caps, and spacers; adjusting location of existing utilities; excavation including exploratory excavation, trench support, dewatering, constructing the specific bedding, backfill including imported backfill if needed, compaction, groundwater barriers; and other miscellaneous items as required to construct the pipeline; trench support; disposal of excess excavated material and damaged materials; pressure testing the newly installed pipelines; and all other appurtenant work, materials and equipment required to construct a complete operable pipeline in accordance with the Drawings and Specifications.

LF pricing will be paid for up to 110% of pipe length as shown on the drawings. Additional pipe will be negotiated as necessary.

<u>Pay Item</u>	<u>Pay Unit</u>
Furnish and Install 54" OD HDPE	LF

8) Furnish and Install 60" ID Steel Pipe Casing (Trenchless)

This unit price per linear foot (LF) item shall be measured for payment along the horizontal plane from beginning station to ending station of the casing as installed. Casing length shall be measured on a continuing line from end to end.

The work includes but is not limited to locating and protection of the existing above and belowground utilities in and along the pipe length; furnishing, transporting, and installing all pipe and materials through trenchless techniques; casing spacers; excavation including launching and receiving pits, exploratory excavation, trench support, dewatering, backfill including imported backfill if needed, compaction, groundwater barriers; and other miscellaneous items as required to construct the pipeline; trench support; disposal of excess excavated material and damaged materials; and all other appurtenant work, materials and equipment required to construct a complete operable casing in accordance with the Drawings, Specifications, and CDOT requirements.

LF pricing will be paid for up to 110% of pipe length as shown on the drawings. Additional pipe will be negotiated as necessary.

<u>Pay Item</u>	<u>Pay Unit</u>
Furnish and Install 60" Steel ID Pipe Casing	LF

9) Furnish and Install Manhole

This unit price item shall be paid per each (EA - Depth) fitting furnished and installed as listed below. The unit price shall include, but not be limited to all costs for materials, excavation, bedding, backfill and compaction, protective wraps, and any other miscellaneous items and work shown or reasonably implied on the Drawings and in the Specifications for this work, and elsewhere in the Contract Documents.

<u>Pay Item</u>	<u>Pay Unit</u>
A. Manhole Slab Base (10 Foot)	EA
B. Manhole Slab Base (15 Foot)	EA
C. Manhole Slab Base (20 Foot)	EA

10) Effluent Box

The lump sum (LS) bid price shall include all of the CONTRACTOR's costs of whatsoever nature including labor, material, and any incidental work and equipment necessary to construct the new effluent box adjacent to the existing effluent box. The unit price shall include, but not be limited to all costs for materials, excavation, bedding, backfill and compaction, grating, reinforcement, protective wraps, connection to the existing effluent box, and any other miscellaneous items and work shown or reasonably implied on the Drawings and in the Specifications for this work, and elsewhere in the Contract Documents.

<u>Pay Item</u>	<u>Pay Unit</u>
A. Effluent Box	LS

11) Diffuser Structure

The lump sum (LS) bid price shall include all of the CONTRACTOR's costs of whatsoever nature including labor, material, and any incidental work and equipment necessary to construct the new diffuser outfall. The unit price shall include, but not be limited to all costs for materials, excavation, bedding, backfill and compaction, header piping, flanges, ports, diffuser nozzles, concrete anchors, connections, reinforcement, protective wraps, de-watering, and any other miscellaneous items and work shown or reasonably implied on the Drawings and in the Specifications for this work, and elsewhere in the Contract Documents.

<u>Pay Item</u>	<u>Pay Unit</u>
A. Diffuser Structure	LS

12) Remove Existing Effluent Pipe and Headwall

The lump sum (LS) bid price shall include all of the CONTRACTOR's costs of whatsoever nature including labor, material, and any incidental work and equipment necessary to remove 24 LF of existing effluent pipe and headwall in Persigo Wash. The unit price shall include, but not be limited to all costs for materials, demolition, labor, disposal, restoration of the Persigo Channel and ground surface, removal of concrete headwall, and any other miscellaneous items and work shown or reasonably implied on the Drawings and in the Specifications for this work, and elsewhere in the Contract Documents.

<u>Pay Item</u>	<u>Pay Unit</u>
A. Remove 24 LF Existing Effluent Pipe and Headwall	LS

13) Abandon Effluent Pipe

The lump sum (LS) bid price shall include all of the CONTRACTOR's costs of whatsoever nature including labor, material, and any incidental work and equipment necessary to abandon in place the existing effluent pipe using a concrete plug with steel reinforcement and Rx Waterstop. Flow fill is required between the existing Effluent Box and the pipe removal noted in Item 12. It is estimated that 75 CY of flow fill will be required to fill the remaining 48" RCP and manhole structure. The unit price shall include, but not be limited to all costs for materials, demolition, labor, restoration of the surface, and any other miscellaneous items and work shown or reasonably implied on the Drawings and in the Specifications for this work, and elsewhere in the Contract Documents.

<u>Pay Item</u>	<u>Pay Unit</u>
A. Abandon Effluent Pipe	LS

14) Site Selective Demolition

The lump sum (LS) bid price shall include all of the CONTRACTOR's costs of whatsoever nature including labor, material, and any incidental work and equipment necessary to remove and salvage the equipment and associated appurtenances as shown on the Drawings from the existing sampling station. Existing equipment is to be placed within the Chlorination Building directly north of the existing sampling station. Contractor shall remove sampling structure from pad and demolish concrete pad. City will repour concrete pad at new sampling location. The unit price shall include, but not be limited to all costs for materials, demolition, labor, restoration of the surface, and any other miscellaneous

items and work shown or reasonably implied on the Drawings and in the Specifications for this work, and elsewhere in the Contract Documents.

<u>Pay Item</u>	<u>Pay Unit</u>
A. Site Selective Demolition	LS

15) Cleanup and Restoration

This lump sum (LS) price shall include all costs to perform all work necessary to remove, restore, install and replace all above grade improvements including but not limited to curb, gutter, sidewalk, pavement, gravel areas, signs, fences, gates, seeding, bank restoration, and all other items not covered elsewhere in the bid form and any other miscellaneous items and work shown or reasonably implied on the Drawings and in the Specifications for this work, and elsewhere in the Contract Documents.

<u>Pay Item</u>	<u>Pay Unit</u>
Cleanup and Restoration	LS

16) Rock Excavation (Potential Quantity)

The measurement for payment of this item will be the total number of cubic yards (CY) of bedrock required to be removed for construction of the proposed pipeline and/or appurtenances; however, no measurement for payment will be made for rock excavation beyond the maximum prescribed trench width or for depths exceeding 12 inches below the pipe; nor for excavation due to negligence or unauthorized operations by the CONTRACTOR. The unit price bid per cubic yard of rock excavation shall include all of the CONTRACTOR's costs of whatsoever nature required to perform the excavation and to replace the void area with granular bedding and/or any other material specifically approved by the ENGINEER. The price bid shall include: excavation, blasting, removal and disposal of rock unsuitable material; furnishing, placing and compacting the approved backfill material required to fill the void area; and all other related and necessary materials, work, and equipment required to excavate the rock in accordance with the Contract Documents. Large cobbles will not be classified as rock excavation. While it is not anticipated that rock will be encountered a unit cost will be required.

<u>Pay Item</u>	<u>Pay Unit</u>
Rock Excavation	CY

17) Bypass Pumping

The lump sum (LS) bid price shall include all of the CONTRACTOR's costs of

whatsoever nature including labor, material, and any incidental work and equipment necessary to complete a temporary bypass of effluent flows from the Persigo Wastewater Treatment Plant during connection of the new effluent structure. A bypass plan shall be submitted for review and approval 48 hrs prior to bypass pumping. The unit price shall include, but not be limited to all costs for materials including primary and backup pumps and hoses, 24 hour monitoring while the system is pumping, and any other miscellaneous items and work shown or reasonably implied on the Drawings and in the Specifications for this work, and elsewhere in the Contract Documents. See appendix for Bypass Flow requirements.

<u>Pay Item</u>	<u>Pay Unit</u>
Bypass Pumping	LS

18) Mobilization and Demobilization

No measurement for payment shall be made for any of the work, materials, and equipment required for mobilization and demobilization. The lump sum (LS) bid price shall include all of the CONTRACTOR's costs of whatsoever nature including labor, material, and any incidental work and equipment necessary for mobilization and demobilization of personnel, equipment and supplies at the project site. This item includes installation of temporary fencing around project work areas, construction and maintenance of all access roads, and any other fencing/security items as deemed necessary by the CONTRACTOR. This item shall also include the establishment of the CONTRACTOR's field offices, buildings and other necessary facilities not specifically defined as a separate pay item, and all other costs incurred of labor and operations which must be performed prior to beginning the other items under this Contract. This item also includes obtaining permits and CONTRACTOR testing. This item may also include provision of required bonds, insurance and preparation of the project schedule. The removal of the CONTRACTOR's equipment, supplies, excess materials, and cleanup of the site are also included in this item. This item is limited to 5% of the total contract amount.

<u>Pay Item</u>	<u>Pay Unit</u>
Mobilization / Demobilization	LS

19) Minor Contract Revisions

No measurement for payment shall be made for this item. It is intended that this bid item be used as a force account for any work deemed by the OWNER to be outside of the original scope. It is not intended to cover any miscellaneous items and work shown or reasonably implied on the Drawings and in the Specifications for this work, and elsewhere in the Contract Documents. Payment must be justified by CONTRACTOR's work

logs and agreed upon with the OWNER before work commences.

<u>Pay Item</u>	<u>Pay Unit</u>
Minor Contract Revisions	LS

1.4 MEASUREMENT

No quantity measurement will be made for any of the lump sum (LS) bid items. The lump sum quantity for each bid item shall include all of the Work required to be performed by the CONTRACTOR for that individual item in the schedule as described above.

1.5 PAYMENT

Each lump sum bid shall include the cost of labor, materials, equipment, transportation, incidentals, and services, properly completed in place and meeting all other requirements of the Contract Documents.

Each unit cost bid shall include the cost of labor, materials, equipment, transportation, incidentals, and services, properly completed in place and meeting all other requirements of the Contract Documents.

Payment of the bid price shall be full compensation to the CONTRACTOR for furnishing all labor, materials, equipment (except as specifically noted for work by others) and incidentals and performing all work as required and defined under these Contract Documents to complete in full the Work described and shown by the Contract Documents.

Payment shall be requested according to the procedures established by the General Conditions.

OWNER will make payment according to the procedures established by the General Conditions.

1.6 PRODUCTS (NOT USED)

1.7 EXECUTION (NOT USED)

END OF SECTION

PART 1 – GENERAL

1.1 DESCRIPTION

- A. Coordinate operations under the contract in a manner which will facilitate progress of the Work.
- B. Conform to the requirements of public utilities and concerned public agencies in respect to the timing and manner of performance of operations which affect the service of such utilities, agencies, or public safety.
- C. CONTRACTOR is solely responsible for removal or relocation of items which may affect Work.
- D. If tight conditions develop, or if conditions differ materially from those shown on the Drawings, coordinate with the ENGINEER to develop appropriate solutions.
- E. Coordinate activities with OWNER.

1.2 CONFERENCES

- A. Hold conferences for coordination of the Work when necessary.
- B. OWNER may hold coordination conferences to be attended by all involved when CONTRACTOR's operations affects, or is affected by, the Work of others.
 - 1. CONTRACTOR shall participate in such conferences accompanied by Subcontractors as required by OWNER

1.3 PROGRESS MEETINGS

- A. CONTRACTOR shall schedule and hold regular bi-weekly (once every two weeks) progress meetings and at other times as requested by the OWNER or as required by the progress of the Work.
- B. Attendance shall include:
 - 1. CONTRACTOR and Superintendent.
 - 2. OWNER's Representative.
 - 3. ENGINEER
 - 4. Others as may be requested by CONTRACTOR or OWNER.
- C. Minimum agenda shall include:

1. Review of Work progress since last meeting.
2. Identification and discussion of items which may affect Work.
3. Review of any pending change orders.
4. Revision of Construction Schedule as appropriate.

D. CONTRACTOR, unless notified, shall preside at meetings and record minutes. Within three (3) of meeting, CONTRACTOR shall distribute minutes to participants and others as required by the OWNER and ENGINEER.

Minutes shall include:

1. 3 Week Look-Ahead Schedule
2. List of Assignments, Person Responsible, and Due Date
3. Decision Log
4. Submittal Log
5. List of RFI's and their status

PART 2 – PRODUCTS (NOT USED)

PART 3 – EXECUTION (NOT USED)

END OF SECTION

AA	Aluminum Association
AABC	Associated Air Balance Council
AAMA	Architectural Aluminum Manufacturers Association
AC	Alternating Current
ACI	American Concrete Standards
ACGIH	American Conference of Governmental Industrial Hygienists
ADA	Americans with Disabilities Act
AFBMA	Antifriction Bearing Manufacturers Association
AGA	American Gas Association
AGMA	American Gear Manufacturers Association
AHDGA	American Hot Dip Galvanizers Association
AHJ	Authority Having Jurisdiction
AIA	American Institute of Architects
AISC	American Institute of Steel Construction
ISI	American Iron and Steel Institute
ANSI	American National Standards Institute
APA	American Plywood Association
ASME	American Society of Mechanical Engineers
ASTM	American Society of Testing Materials
AWG	American Wire Gauge
AWS	American Welding Society
AWWA	American Water Works Association
BICSI	Building Industry Consulting International Network
CDOT	Colorado Department of Transportation

CDPHE	Colorado Department of Public Health and Environment
CDPS	Colorado Department of Public Safety
CFM	Cubic feet per minute
CRSI	Concrete Reinforcing Steel Institute
CSA	CSA Group
DHI	Door Hardware Institute
DIP	Ductile Iron Pipe
DIPRA	Ductile Iron Pipe Research Association
DWG	Drawing
EFF	Effluent Pipe
EOLL	End of Lamp Life
EMT	Electrical Metallic Tubing
EPA	Environmental Protection Agency
FRP	Fiberglass Reinforced Plastic
FSC	Forest Stewardship Council
GALV.	Galvanized
GND	Ground
GPD	Gallons Per Day
GPH	Gallons Per Hour
GPM	Gallons Per Minute
HDPE	High Density Polyethylene
HGL	Hydraulic Grade Line
HI	Hydraulic Institute Standards
HVAC	Heating, Ventilating, and Air Conditioning

HP	Horsepower
IBC	International Building Code
ICC	International Code Council
IEC	International Electro-technical Commission
IEEE	Institute of Electrical and Electronics Engineers
ISA	International Society of Automation
IMC	International Mechanical Code – or – Intermediate Metal Conduit
INV	Invert
LCP	Local Control Panel
LEED	Leadership in Energy and Environmental Design
LF	Linear Feet
MAX.	Maximum
MCC	Motor Control Center
MCIP	Motor Control Instrument Panel
MH	Manhole
MIN.	Minimum
MSL	Mean Sea Level
MSS	Manufacturers Standardization Society of the Valves and Fittings Industry
NAAMM	National Association of Architectural Metal Manufacturers
NBFU	National Board of Fire Underwriters
NBS	National Bureau of Standards
NEBB	National Environmental Balancing Bureau
NEC	National Electric Code
NEMA	National Electrical Manufacturers Association
NESC	National Electrical Safety Code

NETA	National Electric Testing Association
NFPA	National Fire Protection Association
NIOSH	National Institute for Occupational Safety and Health
NPDES	National Pollutant Discharge Elimination Systems
NPSH	Net Positive Suction Head
NPT	National Pipe Thread
NRTL	Nationally Recognized Testing Laboratory
NTU	Nephelometric Turbidity Units
NWRI	National Water Research Institute
O.C.	On Center
OSHA	Occupational Safety and Health Administration
PEFC	Program for the Endorsement of Forest Certification
P&ID	Piping and Instrumentation Diagram
PLC	Programmable Logic Controller
PVC	Polyvinyl Chloride
PSI(G)	Pounds per Square Inch (Gauge)
RCP	Reinforced Concrete Pipe
RIS	Redwood Inspection Services
RMC	Rigid Metal Conduit
ROW	Right of way
RPM	Revolutions per minute
SAE	Society of Automotive Engineers
SDI	Steel Door Institute and Steel Deck Institute
SMACNA	Sheet Metal and Air Conditioning Contractors National Association

SPIB	Southern Pipe Inspection Bureau
SS	Sanitary Sewer
SSPC	Steel Structures Painting Council
STL	Steel
TABB	Testing, Adjusting, and Balancing Bureau
TEFC	Totally Enclosed Fan Cooled
T-STAT	Thermostat
UL	Underwriters Laboratories
UV	Ultraviolet
VAC	Voltage Alternating Current
VDC	Volts Direct Current
VFD	Variable Frequency Drive
W/	With
WCLIB	West Coast Lumber Inspection Bureau
WOG	Water Oil Gas
WSP	Working Steam Pressure
WWPA	Western Wood Products Association

END OF SECTION

SECTION 01130

DEWATERING

PART 1 - GENERAL

1.1 DESCRIPTION

- A. All pipe tunneling pits, tunneling alignment, and open trench pipeline alignments are anticipated to encounter groundwater.
- B. Dewatering is allowed for the construction of the launching shaft or receiving shaft.
- C. Dewatering is not allowed during construction or operation of trenchless construction or in the vicinity of the trenchless construction alignment.
- D. For non-trenchless construction work elements, the Contractor shall supply and operate pumps of sufficient capacity to handle the flow, be maintained at the site, and be constantly attended operationally on a 24-hour per day basis until the Engineer determines their operation can be safely halted. Dewatering used on other non-trenchless construction work elements must be managed to minimize surface subsidence (i.e. settlement) associated with groundwater lowering.
- E. The Contractor shall be responsible to test the water quality of the groundwater and under no circumstances shall the Contractor be allowed to discharge the groundwater directly into Persigo Wash, Pritchard Wash, or the Colorado River, without pretreatment first to remove groundwater contaminants and meet the permit discharge requirements. See General Conditions.
- F. Direct dewatering via subsurface wells without ground stabilization and watertight shoring installations to limit unregulated inflow of groundwater into excavations is not permitted. Prior to and during excavation the Contractor shall stabilize the ground at all excavations via ground stabilization and/or watertight shoring. Installations shall limit groundwater inflow into the excavation to less than 5 gallons per minute (GPM) from a single source such as the excavation wall or floor, or 10 GPM from all sources for any given 100 linear feet of excavation or confined pit area.

1.2 DEWATERING PLAN

The Contractor shall prepare a Dewatering Plan (DP) for the specific reaches of the project. The DP shall provide in detail the Contractor's proposed methods of dewatering and shall be submitted to the Colorado Department of Public Health and Environment (CDPHE), the City of Grand Junction (City), Mesa County (County) and the Engineer prior to the commencement of work. The Contractor shall acquire the required permits from the CDPHE, National Pollutant Discharge Elimination System (NPDES), the City, and County for his means and methods of dewatering considering all factors including the pretreatment/treatment of contaminated groundwater (see General Conditions). The direct discharge of untreated contaminated groundwater will not be allowed. Should excessive fine soils particles at any time during the dewatering process be observed, the dewatering shall be halted immediately and cannot resume until the unsatisfactory condition is remedied by the Contractor at no additional cost to the City and to the satisfaction of the Engineer.

- B. The Contractor shall coordinate the requirements of the dewatering plan with the requirements for the contaminated soils and contaminated groundwater found under General Conditions).
- C. Direct dewatering via subsurface wells without ground stabilization and watertight shoring installations to limit unregulated inflow of groundwater into the excavations require a detailed plan submitting to the engineer including calculations, methods and shop drawings indicating specific dewatering well points.
- D. The Contractor shall submit in his dewatering plan his methods to limit groundwater infiltration at all excavations via ground stabilization and/or watertight shoring. Ground Stabilization and watertight shoring systems shall limit groundwater infiltration into the excavation to less than 5 gallons per minute (GPM) from a single source such as the excavation wall or floor, or 10 GPM from all sources for any given 100 linear feet of excavation or confined pit area.
- E. Direct or indirect discharge of water from dewatering operations requires a Contractor application for discharge permit. The Contractor shall obtain and complete required documents from the City, County, NPDES, and the CDPHE. The Contractor shall allocate the proper amount of time in his Construction schedule for this process. Additionally, the Contractor must implement the following requirements:
 - 1. Discharge of on-site dewatering directly to the City is not permitted. Treated dewatering water may be discharged via sheet flow to Persigo Wash and monitored by the Contractor, as required, for TSS, VSS, BOD, Ammonia, Heavy Metals, Toxicity, Hydrocarbons, Tetrachloroethylene, and Indicator Bacteria to ensure compliance with the City, County, the CDPHE and NPDES permit effluent requirements.
 - 2. For all dewatering operations, each disposal point must have a flow meter to track the discharges. The Contractor shall submit weekly reports showing total amount of discharge at each point with meter readings and other data necessary to support the quantity reported.
- F. All dewatering operations that detect hazardous waste will require pre-treatment to remove the hazardous waste prior to discharge. Refer to General Conditions.
- G. All dewatering operations require the use of a desilting tank. The desilting tank shall be located in a safe and easily accessible location. The system used for desilting the water shall be a baffled structure and shall provide not less than 5 minutes detention time and have a "flow-through" velocity not exceeding 0.2 feet per second at the anticipated peak flow. The desilting box shall be cleaned as required to maintain the detention time and flow- through limitations specified above. The method of desilting and point of disposal of water shall be subject to the Engineer's approval.
- H. Discharge of water from dewatering operations into the Pesigo Wash is governed by NPDES and the CDPHE. If the Contractor determines it is necessary to discharge storm water or groundwater, it must have a Storm Water Management Program (SWMP) and an NPDES permit issued by the CDPHE prior to the discharge, establish an appropriate monitoring program and subcontract a certified lab to run the required analyses at the Contractor's cost. The Contractor will notify the Engineer once permit coverage has been obtained and the discharge can commence. The Contractor is responsible for ensuring that all dewatering operations also comply with all local ordinances.

- I. The Contractor shall provide and maintain, at all times during construction, ample means and devices with which to promptly remove and properly dispose of all water from any source, including water migrating through the bedding of existing trunk sewers or any other existing utilities, entering the excavations or other parts of the work. Costs for dewatering of all water migrating through existing bedding materials as described above, shall be the Contractor's responsibility. Dewatering shall be accomplished by methods that will ensure a dry excavation and preserve the final lines and grades of the bottoms of excavations and adjacent paved surfaces or structures. For pipeline work the methods may include deep wells, well points, suitable rock or gravel placed below the required bedding for draining and pumping purposes, temporary pipelines, or other approved means. The proposed method shall be submitted to the Engineer for review and approval prior to excavation and installation of dewatering equipment.
- J. The Contractor shall make an independent investigation of the soil conditions to be dewatered. The dewatering plan shall be prepared specifically to accommodate soil materials and groundwater conditions of the site. The Contractor remains solely responsible for the dewatering rate that he assumes and is cautioned that groundwater fluctuates seasonally and during storm events, and at differing reaches of the project. A Geotechnical Report prepared by Huddleston Berry is attached to these specifications. See Appendix B for Geotechnical Boring Logs.
- K. No concrete footings or manhole bases shall be constructed in water, nor shall water be allowed to rise over them until the concrete or mortar has set at least 24 hours. Water shall not be allowed to rise unequally against walls until concrete has attained its 28-day strength. Water shall not be allowed to rise above pipe subgrade during pipe laying operations.
- L. The Contractor shall conduct survey settlement monitoring when existing surface features (I-70.) are located in the area of influence of the dewatering operations, creating a potential for settlement. The monitoring shall consist of elevation surveys of multiple points prior to start of dewatering, at reasonable time intervals during the dewatering operation, and at completion of dewatering. The Contractor shall utilize a land surveyor registered in the State of Colorado at the Contractor's expense. Any damage to new work, existing adjacent above and below ground structures, and pipes, due to settlement caused by dewatering activities or any failure of the dewatering system, shall be repaired to the satisfaction of the Engineer, at the Contractor's expense. The Contractor shall notify the Engineer immediately if settlement is recorded. Refer to Specification 02445 for monitoring details.
- M. Dewatering shall be accomplished in a manner that will prevent loss of fines from the foundation, will maintain stability of all excavated slopes and bottoms of excavations, and will permit construction operations to be performed in the dry. Dewatering of excavations shall be performed to the extent required to permit placement of fill materials with compaction in the dry, and to prevent sloughing of the excavation side slopes. If foundation soils are disturbed or loosened by the upward seepage of water or an uncontrolled flow of water, the affected areas shall be excavated and replaced with pipe bedding material at no cost to the City.
- N. Standby pumping equipment shall be on the job site. The standby equipment shall be of reasonable size and quantity to prevent damage, should pumping equipment fail.
- O. The Contractor shall dispose of the water from the work in a suitable manner without

damage to the staging areas, the project, and adjacent property. Conveyance of the water shall not interfere with traffic flow or the operation of the treatment facilities. No water shall be drained into work built or under construction without prior consent of the Engineer. With a permit issued the City, water may be disposed of in the Persigo Wash at a point acceptable to the Engineer.

- P. Upon completion of the dewatering and control of water operation, all temporary works and dewatering facilities shall be removed in a manner satisfactory to the Engineer.

PART 2 – PRODUCTS

Not Used.

PART 3 – EXECUTION

Not Used.

****END OF SECTION****

PART 1 – GENERAL

1.1 DESCRIPTION

- A. Prepare and submit to OWNER for review, estimated construction progress schedule.
 - 1. Construction progress schedule shall be submitted to OWNER 10 days after Notice to Proceed is given.
 - 2. OWNER will review schedules for requirements related to other Work and usage of site.
- B. Night work may be established by CONTRACTOR as regular procedure with written permission of OWNER. Such permission, however, may be revoked at any time by OWNER if CONTRACTOR fails to maintain adequate equipment and supervision for proper prosecution and control of Work at night.
- C. For special restrictions on float and time extensions reference is made to the Agreement.

1.2 CONSTRUCTION PROGRESS SCHEDULE

- A. Form
 - 1. Prepare schedule in form of horizontal bar chart.
 - a. Provide separate horizontal bar for each trade, activity or operation.
 - b. Horizontal Time Scale: Identify first work day of each week.
 - c. Scale and spacing to allow space for notations and future revisions.
 - 2. Format of Listings: Chronological order of start of each item of Work.
 - 3. Identification of Listings: By major Specification section numbers.
- B. Content of Schedule
 - 1. Show complete sequence of construction by activity.
 - 2. Show dates for beginning and completion of each major element of construction and installation dates for major items of equipment. Elements shall include, but not be limited to:
 - a. Shop Drawing receipt from supplier/manufacturer submitted to ENGINEER, review, and return to supplier/ manufacturer.
 - b. Material and equipment order, manufacturer, delivery, installation, and checkout, including allowance items.
 - c. Performance tests and supervisory services activity.
 - d. Erosion Control Installation including Temporary Diversion (Coffer Dam)

- e. Effluent Pipe installation.
 - f. Backfilling, grading, seeding, sodding, landscaping, fence construction, and paving.
 - g. Connection to existing structure.
 - h. Trenchless Boring Schedule
 - i. Subcontractor's items of Work.
 - j. Final cleanup.
 - k. Allowance for inclement weather.
 - l. Miscellaneous concrete placement.
 - m. Demolition and removal.
 - n. Temporary treatment.
3. Show projected percentage of completion for each item as of first day of each month.

C. Schedule Revisions

- 1. Every 30 days revise construction progress schedule to reflect changes in progress of Work.
- 2. Indicate progress of each activity at date of schedule revision.
- 3. Show changes occurring since previous revised submittal.
 - a. Major changes in scope.
 - b. Activities modified since previous submittal.
 - c. Revised projections of progress and completion.
 - d. Other identifiable changes.
- 4. Every 14 days, provide narrative report defining:
 - a. Problem areas, anticipated delays, and impact on schedule.
 - b. Corrective action recommended and its effect.
- 5. Submit to OWNER after any revision.

1.3 DELAYS AND RECOVERY

- A. If, at any time during Project, CONTRACTOR fails to complete an activity by its latest scheduled completion date, CONTRACTOR shall, within 3 working days, submit to OWNER written statement as to how and when CONTRACTOR will reorganize work force to return to current construction progress schedule.
- B. Whenever it becomes apparent from progress evaluation and updated schedule data that milestone completion dates and/or contract completion dates will not be met, CONTRACTOR shall take some or all of following actions:
 - 1. Increase construction staffing in such quantities and crafts as shall substantially eliminate backlog of work.
 - 2. Increase number of working hours per shift, shifts per work day, work days per week, or amount of construction equipment, or combination of foregoing sufficient to substantially eliminate backlog of Work.

PART 2 – PRODUCTS (NOT USED)

PART 3 – EXECUTION (NOT USED)

END OF SECTION

PART 1 – GENERAL

1.1 DESCRIPTION

- A. Submit Shop Drawings, Samples, Operation and Maintenance Manuals and other submittals as required by individual specification sections.
 - 1. ENGINEER will not accept Shop Drawings or other submittals from anyone but CONTRACTOR or as directed by the CONTRACTOR.
 - 2. In relation to the requirements of the General Conditions on the CONTRACTOR's review, the CONTRACTOR assumes full responsibility and risk for misfits due to errors in CONTRACTOR's submittals. CONTRACTOR is responsible for the dimensions and the design of adequate connections and details.
- B. Resubmit to review a correct submittal if errors are discovered during manufacture or fabrication.
- C. Do not use materials or equipment for which Shop Drawings or samples are required until such submittals, stamped by CONTRACTOR and properly marked by ENGINEER, are at the site and available to workmen.
- D. Do not use Shop Drawings which do not bear ENGINEER's mark "REVIEWED" in the performance of the Work. Review status designations listed on ENGINEER's submittal review stamp are defined as follows:
 - 1. REVIEWED
 - a. Signifies material or equipment represented by the submittal conforms to the design concept, complies with the information given in the Contract Documents and is acceptable for incorporation in the Work. CONTRACTOR is to proceed with fabrication or procurement of the items and with related work. Copies of the submittal are to be transmitted for final distribution.
 - 2. REVIEWED AS NOTED
 - a. Signifies material or equipment represented by the submittal conforms to the design concept, complies with the information given in the Contract Documents and is acceptable for incorporation in the Work in accordance with ENGINEER's notations. CONTRACTOR is to proceed with the Work in accordance with ENGINEER's notations and is to submit a revised submittal responsive to notations marked on

- the returned submittal or written in the letter of transmittal.
3. REVISE AND RESUBMIT
 - a. Signifies material or equipment represented by the submittal does not conform to the design concept or comply with the information given in the Contract Documents and is not acceptable for use in the Work. CONTRACTOR is to submit submittals responsive to the Contract Documents.
 4. INFORMATIONAL SUBMITTAL/NOT SUBJECT TO REVIEW
 - a. Signifies submittals which are for supplementary information only; pamphlets, general information sheets; catalog cuts, standard sheets, bulletins and similar data, all of which are useful to ENGINEER or OWNER in design, operation, or maintenance, but which by their nature do not constitute a basis for determining that items represented thereby conform with the design concept or comply with the information given in the Contract Documents. ENGINEER reviews such submittals for general information but not for substance.

1.2 SHOP DRAWINGS

- A. Include the following information as required to define each item proposed to be furnished.
 1. Fabrication and erection drawings.
 2. General outline drawings of items showing overall dimensions, location of major components, and weights.
 3. Detailed equipment installation drawings showing foundation and mounting details, and clearances required for erection, operation and disassembly for maintenance.
 4. Relation to adjacent or critical features of the Work or materials.
 5. Field dimensions, clearly identified as such.
 6. Applicable standards, such as ASTM or Federal Specification numbers.
 7. Type and model number of equipment.
 8. Drawings, catalogs or parts thereof, manufacturer's specifications and data, instructions, performance characteristics and capacities, and other information specified or necessary:
 - a. For ENGINEER to determine that the materials and equipment conform to the design concept and comply with the intent of the Contract Documents.
 - b. For the proper erection, installation, and maintenance of the materials and equipment which ENGINEER will review for general information but not for substance.
 - c. For ENGINEER to determine what supports, anchorages, structural details, connections and services are required for materials and equipment, and the effect on contiguous or related structures, materials and equipment.

9. Parts, devices, controls and accessories forming a part of equipment.
 10. Complete dimensions, clearances required, design criteria, materials of construction and the like to enable ENGINEER to review the information effectively.
 11. Motors: include name of manufacturer, type and model, operating speed, horsepower, voltage, temperature rating, service factor, full load current, power factor at full load, efficiency at full load, code letter, and design letter, service altitude, and other information as required by Section 01605.
 12. Product data for electrical and control panel components including starters, switches, relays, lights, etc.
 13. Schematic diagrams for electrical items and control panels showing external connections, terminal block numbers, internal wiring diagrams and one-line diagrams. A manufacturer's standard connection diagram or schematic showing more than one scheme of connection will not be accepted unless it is clearly marked to show the intended connections.
 14. Bills of materials and lists of spare parts being provided.
 15. Color cards and similar items.
 16. Descriptive literature for paint and coating systems.
 17. Net weight of completed equipment assemblies.
 18. Manufacturer's name, model number, and descriptive literature for all component parts described by a Specification Section.
- B. Manufacturer's standard drawings, schematics and diagrams:
1. Delete information not applicable to the Work.
 2. Supplement standard information to provide information specifically applicable to the Work.
- C. Manufacturer's warranties: reference Section 01740 - Warranties.
- D. Format.
1. Present in a clear and thorough manner.
 2. Minimum sheet size: 8 1/2"x11".
 3. Clearly mark each copy to identify pertinent products and models.
 4. Individually annotate standard drawings which are furnished, cross out items that do not apply, describe exactly which parts of the drawing apply to the equipment being furnished.
 5. Individually annotate catalog sheets to identify applicable items.
 6. Provide a separate transmittal form for each specific item or class of material or equipment for which a submittal is required. Transmittal of a submittal of various items using a single transmittal form will be permitted only when the items taken together constitute a manufacturer's "package" or are so functionally related that expediency indicates review of the group or package as a whole.

7. Reproduction or copies of portions of Contract Documents:
 - a. Not acceptable as complete fabrication or erection drawings.
 - b. Acceptable when used as a drawing upon which to indicate information on erection or to identify detail drawings.
8. Clearly identify the following:
 - a. Date of submission.
 - b. Project title and number.
 - c. Names of CONTRACTOR, Supplier and Manufacturer.
 - d. Specification section number, specification article number for which items apply, intended use of item in the work, and equipment designation.
 - e. Identify details by reference to sheet, detail, schedule or room numbers shown in the Contract Documents.
 - f. Deviations from Contract Documents. Revisions on resubmittals.
 - g. CONTRACTOR's stamp, initialed or signed, certifying to review of submittal, verification of products, field measurements and field construction criteria, and coordination of the information within the submittal with requirements of the Work and the Contract Documents.

1.3 SAMPLES

- A. Submit three (3) sets of samples in an orderly sequence so that interdependent materials or equipment can be assembled and reviewed together.
- B. Individually and indelibly label or tag samples indicating specified physical characteristics, manufacturer's name, color, texture, and other items that are needed for ordering and identification purposes.
- C. Unless otherwise indicated in the Contract Documents, colors and textures of specified items shall be from the manufacturer's standard colors and standard materials, products, or equipment lines as long as they meet the requirements of the Contract Documents.
- D. Upon receiving acceptance from the ENGINEER, one set will be retained by the ENGINEER, two sets of samples will be stamped and dated by the ENGINEER and returned to the CONTRACTOR who shall retain one set and transmit one set to the job site.

1.4 OPERATION AND MAINTENANCE MANUALS

- A. Submittal Requirements:
 1. Submit when work is 80% complete for all Shop Drawings for

equipment having been reviewed by ENGINEER and marked "NO EXCEPTION TAKEN".

2. Submit all other data by the time Work is 90% complete.
3. Do not start or operate equipment until respective operation and maintenance data has been reviewed, accepted and copies made available at the site.
4. The operation and maintenance manuals shall be in addition to instructions or parts lists packed with or attached to equipment when delivered.

B. Include as a minimum the following information:

1. Equipment function, normal operating characteristics, and limiting conditions. Include complete test data where applicable. Provide charts of valve tag numbers, with location and function of each valve, keyed to flow and control diagrams.
2. Operating instructions for startup, calibration, load change requirements, routine and normal operations, adjustments, regulation and control, shutdown, disassembly, reassembly, realignment, balancing, checking, testing procedures to determine performance efficiency, tabulation of proper settings for pressure controls and valves, and emergency conditions. Include location of controls, special tools or equipment required or related instrumentation needed for operation.
3. Lubrication and routine maintenance instructions, including summer, winter, and any special operating instructions.
4. Guide to "troubleshooting".
5. Parts lists, predicted life for parts subject to wear and recommended list of spare parts to be on hand.
6. Outline, cross section, and assembly drawings; engineering data; color coded wiring diagrams as installed.
7. Copy of accepted or as constructed Shop Drawings.
8. Addresses and telephone numbers where parts may be ordered and where service may be obtained including vendor and distributor.
9. Total weight of assembled equipment and weight of individual components.
10. Safety precautions to be taken when operating or maintaining the equipment or when working near it.
11. Diffuser information required in Section 11001

C. Manufacturer's warranties: reference Section 01740 – Warranties.

D. Format:

1. Present in a clear and thorough manner. Bind manuals for similar equipment together in three ring binders or post binders. Use minimum number of binders, maximum thickness per binder 4 inches.

2. Provide divider tabs for each Division per the specifications.
3. Order of materials shall be the same as the order of specifications in the Project Manual.
4. Minimum sheet size: 8"x11".
5. Clearly mark each copy to identify pertinent products and models.
6. Fold drawings larger than 11"x17" and insert into individual pockets bound into the manuals.
7. Enclose in clear plastic sheets pages subject to frequent usage by operators.
8. Individually annotate standard drawings which are furnished, describe exactly which parts of the drawing apply to the equipment being furnished.
9. Individually annotate catalog sheets to identify applicable items.
10. Include a Table of Contents indicating all provisions included in each manual.
11. Clearly identify the following:
 - a. Date of submission.
 - b. Project title and number.
 - c. Names of CONTRACTOR, Suppliers and Manufacturers, include telephone numbers and addresses.
 - d. Names of subcontractors with telephone numbers and addresses, contracted by CONTRACTOR for servicing and maintenance of portions of the project.
 - e. Specification section number, intended use of item in the Work, an equipment designation.
 - f. Identify details by reference to sheet, detail, schedule, or room numbers shown in the Contract Documents.

1.5 SUBMISSION REQUIREMENTS

- A. Make submittals promptly in accordance with approved schedule, and in such sequence as to cause no delay in the Work or in the work of any other CONTRACTOR.
- B. Do not submit operation and maintenance data with Shop Drawings unless so specified or required by ENGINEER to determine if equipment will comply with the Contract Documents.
- C. Minimum number required:
 1. Shop Drawings.
 - a. The number CONTRACTOR requires (a maximum of four), plus one (1) copies which will be retained by ENGINEER.
 - b. Submit three (3) additional copies for inclusion in Operation and Maintenance manuals where Operation and Maintenance manuals are called for. Where field modifications are made after acceptance, indicate "as constructed" conditions, mark copies "AS CONSTRUCTED",

- and submit prior to Substantial Completion.
2. Operation and Maintenance Manuals
 - a. Number CONTRACTOR requires, plus three (3) copies to ENGINEER, for disbursement to OWNER.

1.6 RESUBMISSION REQUIREMENTS

- A. Make corrections or changes required by ENGINEER and resubmit until accepted.
- B. In writing call ENGINEER's attention to deviations that the submittal may have from the Contract Documents.
- C. In writing call specific attention to revisions other than those called for by ENGINEER on previous submissions.
- D. Shop Drawings.
 1. Include additional drawings that may be required to show essential details of any changes proposed by CONTRACTOR along with required wiring and piping layouts.

PART 2 – PRODUCTS (NOT USED)

PART 3 – EXECUTION (NOT USED)

END OF SECTION

PART 1 – GENERAL

1.1 DESCRIPTION

- A. Substantiate costs when such items as mobilization and Project Closeout expense, and Bond premium, are listed separately in the schedule of values. Mobilization and demobilization have been placed together under one bid item. Mobilization costs are not to exceed 4% of Bid.
- B. Overhead and profit will not be listed as separate items.
- C. All pay items will be supported with acceptable documentation when required by ENGINEER.
- D. An unbalanced schedule of values providing for overpayment of CONTRACTOR on items of Work which would be performed first will not be accepted.
- E. The schedule of values will be revised, if required, and must be acceptable to OWNER prior to processing the first progress payment.

1.2 FORM AND CONTENT

- A. The schedule of values shall separate the costs by Work activity. CONTRACTOR's standard forms and computer listings prepared in conjunction with the construction schedule will be acceptable.
- B. Separate the Work activities identified as a part of the Construction Schedule into the individual cost categories.
 - 1. Identify the dollar amount of each activity allocated to applicable cost categories.
 - 2. Schedule of values may be more definitive than the construction schedule.
- C. Coordinate schedule of values with the construction schedule specified in Section 01310 – Construction Schedule.

1.3 SUBMITTAL

- A. Submit three (3) copies of the schedule of values for acceptance with Construction Progress Schedule.

PART 2 – PRODUCTS (NOT USED)

PART 3 – EXECUTION (NOT USED)

END OF SECTION

PART 1 – GENERAL

1.1 SUBSTANTIAL COMPLETION

- A. Reference the General Conditions.
- B. All work except the following must be complete for Substantial Completion:
 - 1. Seeding.
 - 2. Final cleanup.
 - 3. Extended Manufacturer's Field Services.

1.2 FINAL INSPECTION AND ACCEPTANCE

- A. Reference the General Conditions.
- B. All Work except the following must be complete for Final Acceptance.
 - 1. Not applicable.

PART 2 – PRODUCTS (NOT USED)

PART 3 – EXECUTION (NOT USED)

END OF SECTION

PART 1 – GENERAL

1.1 DESCRIPTION

- A. Execute cleanup, during progress of the Work, and at completion of the Work.
- B. Adequate cleanup will be a condition for recommendation of progress payments.
- C. Store volatile wastes in covered containers and dispose offsite.
- D. Provide on-site covered containers for the collection of waste materials, debris and rubbish.
- E. Neatly store construction materials, such as concrete forms, when not in use.
- F. Broom pavements.

1.2 DISPOSAL

- A. Wastes shall not be buried or burned on the site or disposed of into storm drains, sanitary sewers, streams, or waterways.
- B. Remove waste materials, clearing materials, demolition materials, unsuitable excavated materials, debris, and rubbish from the site at least weekly and dispose of at disposal areas furnished by CONTRACTOR away from the site.

PART 2 – PRODUCTS (NOT USED)

PART 3 – EXECUTION (NOT USED)

END OF SECTION

PART 1 – GENERAL

1.1 DESCRIPTION

- A. This section describes the disposition of warranties submitted on the project.
- B. It is explicitly understood that nothing in any warrantee shall relieve the CONTRACTOR from rights and privileges of the OWNER as set forth in these Contract Documents in relation to products and services as intended or described in these Contract Documents.
- C. It is explicitly understood that all manufacturer's warranties are an attempt to limit their liability under law. As a condition of all warranties submitted by the manufacturer or others on this project it is understood that the requirements of this section supersede all warranties submitted. The ENGINEER will not review warranties as to substance of manufacturer's trying to limit their liability. All such attempts to limit liability that is in violation of these Contract Documents is void and without legal effect.
- D. The submittal of warranties on this project shall not in any way relieve CONTRACTOR of their responsibilities for CONTRACTOR's General Warranty and Guarantee and Correction Period as defined in the General Conditions and related requirements contained in these Contract Documents.

1.2 SUBMITTAL OF WARRANTIES NOT CALLED FOR IN THE CONTRACT DOCUMENTS.

- A. If the time period of the warrantee falls within the correction period specified for the project the warrantee shall be without effect on the project. CONTRACTOR may use said warrantee for their own use if CONTRACTOR elects. The ENGINEER will not review said warranties if submitted.
- B. If CONTRACTOR submits warranties and the time period of the warrantee exceeds the correction period specified for the project these warranties shall be accepted.

1.3 SUBMITTAL OF WARRANTIES CALLED FOR IN THE CONTRACT DOCUMENTS.

- A. Warranties called for in the Contract Documents shall be accepted as follows:
 - 1. ENGINEER will review the warrantee only to verify that the warrantee defines the requirements called for in the Contract

Documents.

2. During the Correction Period of the project the warrantee shall be for the use of the CONTRACTOR as it relates to CONTRACTOR's responsibilities under the correction period.
3. After the expiration of the correction period the rights under the warrantee shall pass to the OWNER for OWNER's use of their facilities.

PART 2 – PRODUCTS (NOT USED)

PART 3 – EXECUTION (NOT USED)

END OF SECTION

PART 1 – GENERAL

1.1 DESCRIPTION

- A. Maintain at the site one record copy of:
 - 1. Documents and samples called for in Section 01340.
 - 2. Field Test Records.
 - 3. Certificates of compliance.
 - 4. Payments.

1.2 MAINTENANCE OF DOCUMENTS AND SAMPLES

- A. Store documents in CONTRACTOR's field office apart from documents used for construction.
 - 1. Provide files and racks for storage of documents.
 - 2. Provide storage space for samples.
- B. File documents and samples in accordance with the Specification's section numbers.
- C. Maintain documents and samples in a clean, dry, legible condition and in good order.

1.3 RECORDING

- A. Label each document "PROJECT RECORD" in neat large printed letters.
- B. Record information concurrently with construction progress.
 - 1. Do not cover Work until required information is recorded.
- C. Marking of Project Records.
 - 1. Legible and with a dark pen or pencil.
 - 2. Ink shall not be water based or subject to easy smearing.
- D. Mark Drawings to record actual construction.
 - 1. Field dimensions, elevations, and details.
 - 2. Changes made by a Modification.
 - 3. Details not on original Drawings.
 - 4. Horizontal and vertical locations of underground utilities and appurtenances, referenced to a minimum of two permanent surface improvements.
 - 5. Depths of various elements of foundation in relation to project datum.
 - 6. Location of internal utilities and appurtenances concealed in the

construction, referenced to visible and accessible features of the structure.

1.4 SUBMISSION

- A. Accompany submittal with transmittal letter in duplicate containing:
1. Date.
 2. Project title and number.
 3. CONTRACTOR's name, address, and telephone number.
 4. Index containing title and number of each Record Document.
 5. Signature of CONTRACTOR or his authorized representative.

PART 2 – PRODUCTS (NOT USED)

PART 3 – EXECUTION (NOT USED)

END OF SECTION

DIVISION 2
SITework

PART 1 – GENERAL

1.1 SECTION INCLUDES

- A. Reference the General Conditions.
- B. Reference the Erosion Control Notes included in the Drawings.
- C. Removal of paving, curbs, gutters, and walks.
- D. Clear site of plant life, grass, and designated trees.
- E. Removal of unwanted structures.
- F. Removal of designated pipes.
- G. Topsoil excavation.

1.2 REGULATORY REQUIREMENTS

- A. Conform to City, County, State, and Federal regulations for disposal of debris.
- B. Coordinate clearing Work with the OWNER.
- C. Conform to the USACOE 404 Permit requirements. See Erosion Control Notes on the Drawings for additional requirements as well as a copy of the permit attached to this document.

PART 2 – PRODUCTS (NOT USED)

PART 3 – EXECUTION

3.1 PREPARATION

- A. OWNER is responsible for identifying trees or other existing features slated for protection. Do not remove any trees without express permission of the OWNER.
- B. Verify that existing features designated for protection are tagged by the OWNER or identified.

3.2 PROTECTION

- A. Locate, identify, and protect utilities that remain from damage.

- B. Coordinate with the OWNER.
- C. Protect trees, plant growth, and features not designated for removal.
- D. Protect bench marks, horizontal control points, survey monuments, property pins, and existing structures from damage or displacement. Any items damaged shall be re-set by a Colorado registered Land Surveyor.

3.3 CLEARING

- A. Clear areas required for access to site and execution of Work.
- B. Remove curbs, gutters, and sidewalks as required.
- C. Remove trees and shrubs indicated. Remove stumps and root system to a depth of 4 feet and horizontally 10 feet from center of stump.

3.4 REMOVAL

- A. Removal debris, rock, and extracted plant life from site.
- B. Remove unwanted materials and structures.

3.5 TOPSOIL EXCAVATION

- A. Excavate topsoil from areas to be further excavated or re-graded.
- B. Stockpile topsoil for replacement at the end of final grading.
- C. See Erosion Control notes for excavation of wetland topsoil.
- D. Remove top 12" of armoring layer (6-12" diameter cobbles) on the Colorado Riverbed and stockpile for replacement when work is completed.

END OF SECTION

PART 1 - GENERAL

1.1 DESCRIPTION

- A. This section covers the demolition, abandonment, salvage and disposal of portions of the existing piping and outlet structure as indicated on the Drawings and Specifications
- B. Plugging of existing opening in effluent box shall be with Cast In Place Concrete per section 03300 and include RX-waterstop at joint.

1.2 SUBMITTALS

- A. Submit shop drawings on all materials specified.

PART 2 - PRODUCTS

2.1 NON-SHRINK BACKFILL/UNSHRINKABLE BACKFILL/FLOW-FILL

- A. Mix Design

<u>Ingredients</u>	<u>lbs./CY</u>
Cement (0.45 sack)	42
Type I-II (ASTM C150)	
Water (39 gallons)	325
Coarse Aggregate (Size no. 57)	1700
Sand (ASTM C-33)	1845

- B. Air Content: 1.5%
- C. Maximum 28 day strength: 60 psi
- D. Minimum 24 hour strength: 10 psi
- E. Slump: 6 inches

PART 3 - EXECUTION

3.1 REMOVAL OF PIPING AND OUTLET STRUCTURE

- A. CONTRACTOR shall remove existing pipes and outlet structure into Persigo Wash as shown on Drawings.
- B. Contractor shall plug existing hole in effluent box with structural concrete.
- C. Remove piping as shown on the Drawings in area of construction and

disposed of offsite at dumping area provided by the CONTRACTOR.

- D. Slope into Persigo Wash shall be restored to match adjacent slopes and mimic historic channel.

3.2 ABANDONMENT

- A. CONTRACTOR shall abandon in place existing buried pipe, manholes and appurtenances that are no longer required due to the new piping where directed by the OWNER. The intent of the project is to remove 24 LF of the existing outfall piping and Abandon the remaining.
 - 1. Fill all inlet and outlet pipes to their crown with concrete, to a minimum distance of 3 feet from the outer wall of the manhole base section.
 - 2. Repair any damage to adjacent structures, properties, and/or pavements.
 - 3. Restore vegetation.

3.3 DISPOSAL

- A. Remove demolition debris from Work site weekly.
- B. All abandoned material shall be disposed of offsite at dumping area provided by the CONTRACTOR.

3.4 REMOVAL OF PIPING

- A. CONTRACTOR shall remove existing pipes and outlet structure as shown on Drawings.
- B. Remove piping as shown on the Drawings in area of construction and disposed of offsite at dumping area provided by the CONTRACTOR.

END OF SECTION

PART 1 - GENERAL

1.1 SECTION INCLUDES

- A. Remove and salvage the equipment and associated appurtenances as shown on the Drawings from the existing sampling station. Equipment to be placed within the Chlorination Building directly north of the existing sampling station. Contractor shall remove sampling structure from pad and demolish concrete pad. City will repour concrete pad at new sampling location.

1.2 SITE CONDITIONS

- A. CONTRACTOR shall be responsible for verifying that each and every utility in the vicinity of the work to be demolished, above and below grade, has been de-activated and is safe for demolition and removal.
- B. All existing work to remain, connected and/or adjacent to the work to be removed, shall be shored, braced, covered, or otherwise protected from damage due to demolition operations or the temporary removal of portions of any structure.

1.3 DISPOSAL OF MATERIALS AND DEBRIS

- A. All demolition materials, debris, waste, or other materials shall be collected, stored, handled, managed, and disposed in accordance with currently accepted practices at an approved, licensed, or permitted facility in accordance with applicable federal, state, and local ordinances, rules, and regulations.

1.4 PERMITS

- A. CONTRACTOR shall obtain, at his expense, any and all permits required by local, state, and federal agencies. Copies of permits shall be maintained at the site and readily produced upon request.
- B. All inspections required by the permits will be required and provisions for safe access to perform inspections shall be made by the CONTRACTOR.

PART 2 - PRODUCTS (NOT USED)

PART 3 - EXECUTION

3.1 TEMPORARY SUPPORT

- A. Provide and install all temporary shoring, bracing and other supports as is necessary to prevent movement, cracking, collapse, etc. of for existing work to remain. Drilled holes, inserts, embedment and other temporary attachments that will remain visible following completion of the work shall not be permitted.

3.2 CONTAINMENT AND SECURITY

- A. Construct temporary working platform(s) below and temporary containment barriers around, all demolition work prior to commencing Work.
- B. Contain all debris, dust, fumes, etc. controlling them within the immediate vicinity of removal, through-out the duration of the demolition operations. Do not allow any materials to free-fall, rotate, swing, or otherwise release uncontrollably unless adequate precautions and protections are in place.
- C. Provide and install physical barriers to prevent access to areas that may be hazardous to workers or the public.

3.3 DEMOLITION

- A. Demolition operations shall not induce excessive vibrations to remaining, adjacent or nearby structures.

3.4 DEBRIS AND WASTE REMOVAL AND DISPOSAL AND CLEANUP

- A. Remove all debris, trash and demolition-related waste from site.
- B. Dispose of waste materials in a proper manner, in conformance with local, state and federal regulations. Submit copies of all receipts, manifests and other documentation from receiving waste site(s).
- C. Clean up spillage and wind-blown debris from public and private areas.

END OF SECTION

PART 1 - GENERAL

1.1 SUMMARY

- A. Section includes:
 - 1. Disposal of unsuitable or excessive excavated materials.
- B. Related sections include but are not necessarily limited to:
 - 1. Division 0 - Bidding Requirements, Contract Forms, and Conditions of the Contract.
 - 2. Division 1 - General Requirements.
 - 3. Section 02300 – Earthwork and Trenching.

1.2 MEASUREMENT AND PAYMENT

- A. No measurement or direct payment will be made for work prescribed and accepted in this Section, but shall be included in bid schedule Items 02316, 02440, 02623, 03300, 11001, 15064, or CDOT sections 706 or 712.13 for which this work is required.

PART 2 - PRODUCTS (NOT APPLICABLE TO THIS SECTION)

PART 3 - EXECUTION

3.1 USE OF MATERIALS

- A. Use all suitable material from required excavation, or as much thereof as may be required, for backfill, embankment, or other required earthwork.

3.2 WASTE MATERIALS

- A. Waste material from required excavation which is not suitable or required for backfilling may not be disposed on-site.

3.3 PROCEDURES

- A. Use soil erosion and sediment control procedures in accordance with CDOT Specification Section 208.

PART 4 - ACCEPTANCE

- 4.1 Acceptance by OWNER will be based on Visual Inspection.

END OF SECTION

PART 1 – GENERAL

1.1 SECTION INCLUDES

- A. This section covers site grading, excavation, subgrade preparation, backfill, compaction, trenching, and finish grading for underground piping, structural fills, embankments, and appurtenances. It also includes disposition of excess materials, provision for imported materials, sheeting, shoring, pumping, and dewatering, and temporary drainage operations.
- B. Classification of Excavated Material:
 - 1. Excavated materials will not be classified. Excavation and trenching includes the removal and subsequent handling of all materials excavated or otherwise removed in performance of the Work, regardless of the type, character, composition or condition thereof.
- C. Caution in Excavation:
 - 1. The CONTRACTOR shall proceed with caution in the excavation and preparation of trench so that the exact location of underground utilities and structures, both known and unknown, may be determined. The CONTRACTOR shall be held responsible for the repair of such structures when broken or otherwise damaged because of carelessness on his/her part.

1.2 GENERAL REQUIREMENTS

- A. With reference to the terms and conditions of the construction standards for excavations set forth in the OSHA Safety and Health Regulations for Construction, Chapter XVII of Title 29, CFR, Part 1926, the CONTRACTOR shall employ a competent person and, when necessary, a registered professional engineer, to act upon all pertinent matters of the Work of this section.
- B. Excavations shall provide adequate working space and clearances for the work to be performed therein and for installation and removal of concrete forms. In no case shall excavation faces be undercut for extended footings.
- C. Subgrade surfaces shall be clean and free of loose material of any kind when concrete is placed thereon.

1.3 QUALITY ASSURANCE

- A. Soil Compaction Tests.

1. ASTM D698 or AASHTO T99 - Standard Method of Test for Moisture Density Relations of Soils Using a 5.5 lb. Rammer and a 12 inch drop.
 - a. Use method A, B, C, or D, as appropriate, based on soil condition and judgment of the testing laboratory.
 - b. Sample tests will be representative of materials to be placed.
 - c. Determine and provide maximum density curve for each type of material encountered or utilized.
 - d. Include Atterberg Limits, gradation and specific gravity.
2. ASTM D4253, D4254 - Test of Relative Density of Cohesionless Soils.
3. Test results will be basis for Field Quality Control.

1.4 SUBMITTALS

- A. Test Certificates. Submit test certificates to enable ENGINEER to determine compliance with the Specifications of each of the following materials from each proposed source or supplier:
 1. Stabilization material.
 2. Granular material.
 3. Imported materials.
- B. Provide with this certificate a density test of a typical sample.
 1. ASTM D698 or AASHTO T99.
 2. ASTM D4253, D 4254.

1.5 JOB CONDITIONS

- A. Limits of Construction.
 1. Confine operations to within the project areas.
- B. Operations.
 1. Do not use mechanical equipment in locations where its operation would cause damage to trees, culverts, or other existing property, utilities or structures above or below ground. Hand-excavate all such locations.
- C. Drainage and Groundwater.
 1. Maintain excavations and trenches free from water during construction.
 2. Remove water encountered in excavations and trenches during construction to the extent necessary to provide a firm subgrade and remove standing water.
 3. Divert surface runoff and use sumps, gravel blankets, well points, drainage line or other means necessary to accomplish the above.
 4. Maintain excavations and trenches free from water until the structure, or pipe to be installed therein is completed, to the extent that no damage from hydrostatic pressure, flotation or other cause will result.

5. A dewatering permit is required prior to discharging groundwater. See CDOT Spec Section 107.25.
 6. Control potential on-site erosion per OWNER requirements. Reference CDOT Specification Section 208 Erosion Control as well as Erosion Control Drawing Notes.
 7. See Section 01130 – Dewatering for additional information.
- D. Sheeting and Shoring
1. Use sheeting and shoring when banks are not cut back on a stable slope and as necessary to protect workmen, the Work and adjacent structures and facilities from caving or sliding, or as specifically required by this document.
 2. The trench shall be adequately supported and the safety of workers provided for as required by the most recent standards adopted by the O.S.H.A. Standards Board.
 3. Sheeting removal.
 - a. Do not remove prior to backfilling.
 - b. Use effective methods to protect construction, other structures, utilities and properties during sheeting removal.
 - c. Fill voids left by sheeting removal with dry sand.
- E. Sequencing.
1. Perform pipeline installation within 100 linear feet of trench excavation.
 2. Perform trench backfill within 100 linear feet of pipe installation.
 3. Perform clean-up within 400 linear feet of trench excavation.
- F. Underground obstructions.
1. Underground obstructions known to ENGINEER are shown on Drawings. However, locations shown may prove inaccurate and other obstructions not known to ENGINEER may be encountered.
 2. Notify each utility owner and request utilities be field located by surface reference at least 48 hours prior to trenching or excavation.
 3. Expose and verify size, location and elevation of underground utilities and other obstructions where conflicts might exist sufficiently in advance to permit changes in the event of conflict.
 - a. Notify OWNER in case of conflict.
 - b. In case of conflict, the proposed Work may be changed by ENGINEER.
 - c. Note all underground utilities and obstructions on Project Record Documents. Included type, size, material, location, and elevation.
 4. Maintain, protect and support by shoring, bracing or other means existing utilities and appurtenances.
 5. Take such protective measures as the utility may direct where alterations or moving of utilities is required.

6. If CONTRACTOR elects to remove underground obstructions, replacement shall be done with new materials. Restoration shall be equal or better than the original conditions.

G. Weather.

1. Do not backfill or construct fills or embankments during freezing weather.
2. Do not place backfill, fill or embankment on frozen surfaces.
3. Do not place frozen materials, snow or ice in backfill, fill or embankments.
4. Do not deposit, tamp, roll or otherwise mechanically compact backfill in water.

1.6 PRODUCT DELIVERY, STORAGE, AND HANDLING

- A. Select transportation schedule and truck routes with approval of OWNER to keep impacts on public to a minimum.
- B. Do not stockpile materials against existing structures or Work.

1.7 MAINTENANCE AND CORRECTION

- A. Scarify surface, reshape, and compact to required density completed or partially completed areas of Work disturbed by subsequent construction operations or by adverse weather.
- B. Maintain and correct backfill, fill and embankment settlement and make necessary repairs to pavement structures, seeding and sodding which may be damaged as a result of settlement for period of one (1) year after Substantial Completion and acceptance of the Work.
- C. CONTRACTOR may perform such maintenance and correction by subcontract.
- D. Submit with application for final payment a copy of any subcontract or authorization as evidence of CONTRACTOR's faithful intention to perform necessary corrections during the one (1) year correction period.

PART 2 – PRODUCTS

2.1 FILL MATERIAL

- A. Structure Backfill, Fill and Embankment. (Select Fill Material)
 1. Existing excavated soil, granular sand, gravel, cobble and boulder material, free from frozen material, organic material, trash, glass, broken concrete, other corrosive or deleterious material and rocks, stones, or boulders larger than 6 inches in any dimension.

- a. Use suitable on-site excavation or stockpiled materials to the greatest extent possible.
 - b. Haul excess and unsuitable material.
 - c. Excavated bedrock shall not be used as structure backfill or trench backfill.
 - d. Structure backfill material shall have a liquid limit less than 35 and a plastic index less than 6 when tested in accordance with AASHTO T-89 and T-91, respectively. Fill and embankment material need not meet liquid limit and plastic index above.
2. Other size restrictions are as follow:
- a. 1-1/2 inches in any dimension for material placed within one foot of structures, pavement subgrade or finished surface in unpaved areas.
 - b. 6 inches in any dimension for the remainder of the excavation provided they are distributed in the finer material.

B. Granular Material.

- 1. Crushed rock or gravel meeting the requirements of ASTM C33 with 100% passing a 3/4 inch sieve and not more than 5% passing No. 4 sieve, or
- 2. Well graded crushed, stone or gravel: ASTM C33, gradation 67.

C. Pea Gravel

- 1. Naturally round aggregate with 100% passing a 3/8 inch sieve and not more than 5% passing No. 4 sieve.

2.2 STABILIZATION MATERIAL

A. Top 6 inches of pipe subgrade.

- 1. Pit-run gravel or crusher-run rock: ASTM D448, size No. 357 (2" to No. 4).

<u>SIZE</u>	<u>PERCENT PASSING</u>
2 1/2"	100
2"	95-100
1"	35-70
1/2"	10-30
#4	0-5

- 2. Or, Granular material above.

B. Subgrade below top 6 inches - Same as top 6 inches except that broken concrete and rock may be included in sizes which permit compaction as specified without discernible voids.

C. Acceptable types of filter fabric and their manufacturers:

- 1. Mirafi 140, by Celanese.
- 2. Supac 4 1/2 NP, by Phillips.

3. Typar 3471, by Dupont.
4. GTF 130D, by Exxon.

2.3 BEDDING MATERIALS

- A. Definition:
1. Materials placed from the subgrade to an elevation 12 inches above the top of pipe; including laterals.
 2. CDOT Class 1 Material
- B. Pea Gravel
1. Naturally round aggregate with 100% passing a 3/8 inch sieve and not more than 5% passing No. 4 sieve.
- C. Granular material
1. Angular crushed rock, free of corrosive properties and conforming to the following gradation limits when tested by means of laboratory sieves.

<u>SIZE</u>	<u>PERCENT PASSING</u>
1"	100
3/4 Inch	90-100
3/8"	20-55
#4	0-10
#8	0-5

- D. Flowable Fill - (Non-shrinkable trench backfill)
1. Non-shrinkable trench backfill shall meet the following requirements:

<u>Ingredients</u>	<u>lbs/C.Y.</u>
Cement (0.45 sacks)	42
Type of Cement, ASTM C150, I or II	
Water (39 gallons)	325
Coarse Aggregate, ASTM C33, 3/4 inch	1700
Sand, ASTM C33	<u>1845</u>
TOTAL WEIGHT PER CUBIC YARD	3912

2. Minimum Slump: 6 inches
 3. Minimum 28 day strength: 40 psi
 4. Maximum 28 day strength: 60 psi
 5. Non-shrinkable trench backfill shall be adequately vibrated to ensure consolidation.
- E. Concrete.
1. Compressive strength: 3000 psi minimum and 4000 psi maximum at 28 days minimum.
 2. Meet requirements of Section 03300 Cast In Place Concrete.

- F. Barrier material.
 - 1. Soil Classification.
 - a. GC - clayey gravels, gravel-sand-clay mixtures.
 - b. SC - clayey sands, sand-clay mixtures.
 - c. CL - inorganic clays of low to medium plasticity, gravelly clays, sandy clays, silty clays, clean clays.
 - d. Material shall not be lumpy or hard but shall be finely divided, suitable, and free from stones.
 - e. Flowable fill. Refer to Article 2.3 D., above.

2.4 TRENCH BACKFILL MATERIAL

- A. Trench backfill material for pipeline shall be either soil excavated from the trench, or imported soil. Existing excavated soil used for trench backfill, shall be free from frozen matter, stumps, roots, brush, other organic material, corrosive material, debris and other items. In addition, suitable material shall meet the following requirements:
 - 1. Upper portion of trench: Material placed within one (1) foot of pavement subgrade or finished surface in unimproved areas to a point eighteen (18) inches above the pipeline, shall be soil free from rocks greater than six (6) inches in nominal diameter.
 - 2. Other portions of trench: From a point eighteen (18) inches above the pipeline to within one (1) foot of the pavement subgrade or finished surface in unimproved areas, maximum size of any rock in the trench backfill shall be twelve (12) inches in any dimension provided these rocks are distributed in the finer material.
 - 3. If imported soil is used for trench backfill, it shall meet the AASHTO/USCS classification of the excavated material at the existing soil stratification.

PART 3 – EXECUTION

3.1 GENERAL

- A. Preparation.
 - 1. Clear and strip surface vegetation, sod and organic topsoil from subgrades for permanent construction, fills or embankments, six (6) inch minimum depth.
 - 2. Clear areas to be occupied by permanent construction or embankments.
 - a. Remove and dispose of stumps, roots over 4 inches in diameter and matted roots to the following depths:
 - 1) 18 inches below footings and parking areas
 - 2) 12 inches below walks
 - 3) 24 inches below roadways
 - b. Fill depressions with Granular Material.

- B. Stockpiling Excavated Materials.
 - 1. Pile suitable material for backfilling in an orderly manner a sufficient distance from banks of excavations and trenches to avoid overloading and to prevent slides or cave-ins.
 - 2. Remove and dispose of excess excavated materials not suitable or not required for backfilling.
 - 3. Do not stockpile excavated material against structures or appurtenances.

- C. Dispose all on-site excavated rock and bedrock material; excess excavated materials and material not suitable for use on the project in the designated area as shown on the drawings. If excavated materials are disposed on private property, written permission shall be obtained from the property owner and a copy given to ENGINEER.

3.2 EXCAVATION

- A. Provide adequate space and clearances for the Work and for installation and removal of concrete forms.

- B. Do not undercut excavated faces for extended footings.

- C. Granular material for footings and grade beams shall be founded on original, undisturbed soil or on structural backfill extended to the undisturbed soil. Granular material for footings and grade beams shall not be founded on existing fill at the site. If existing fill is at subgrade, excavate to original undisturbed soil and bring to proper grade with structural backfill.

- D. Fill material encountered at the site shall be removed. It may be stockpiled for reuse in backfills and embankments if it meets the requirements of the Specifications.

- E. Unauthorized Excavation.
 - 1. Except where otherwise shown, specified or authorized by ENGINEER, replace materials excavated below the bottom of concrete walls, footings slabs on grade and foundations with concrete at the same time and monolithic with the concrete above.

3.3 SUBGRADE

- A. Scarify to a depth of six (6) inches and compact.

- B. Do not work on subgrade while ground is frozen or muddy.

- C. Remove exposed cobbles, stones or boulders greater than six (6) inches in

size that create an irregular surface at subgrade. Backfill resulting voids with Granular Fill compacted to specified density.

- D. Carefully compact near structures and over pipe to avoid damage.
- E. Compact and consolidate subgrades for structures or trench bottoms such that they are free from mud and sufficiently stable to remain firm, dense and intact under the feet of the workmen.
 - 1. Reinforce subgrades with Stabilization Material which are otherwise solid, but become muddy on top due to construction operations.
 - 2. Finish stabilized subgrade to elevations shown on Drawings.
- F. Stabilization:
 - 1. Wherever wet or otherwise unstable material that is incapable of supporting the pipe or structure is encountered in the bottom of the excavation or trench,
 - a. Overexcavate such material to a depth suitable for construction of a stable subgrade.
 - b. Backfill overdepth with Stabilization Material or Granular Material.
 - 2. Use filter fabric where necessary around Stabilization Material, Granular Bedding Material and on the subgrade to stabilize subgrade and prevent fines from migrating into granular materials.
- G. Level and roll subgrade so that surface materials will be compact and bond well with the first layer of the backfill, fill or embankment.
- H. Underlay slabs on grade with a minimum of twelve (12) inches of Granular Material, or greater depth if shown on Drawings, covered by 8 mil polyethylene sheeting.
- I. Place and compact fill to an elevation at least one foot above top of proposed pipe where pipe will pass through backfill or fill prior to beginning trenching.

3.4 BACKFILL, FILL, AND EMBANKMENT

- A. Import material if compaction cannot be obtained with job excavated material or if job excavated material does not meet the Specifications. Material will require careful excavation and sorting.
- B. Use of rocks or stones within the allowable size limit in the remainder of backfills, trenches, fills or embankments is subject to their not interfering with proper compaction.
- C. Place on suitably prepared subgrade.
- D. Spread and compact materials in horizontal lifts not exceeding eight (8)

inches in uncompacted thickness but in thin enough layers to provide adequate compaction throughout the entire lift.

1. Spread and level material deposited in piles or windrows prior to compaction.
 2. Distribute material so as to preclude the formation of lenses of material differing from the surrounding materials.
- E. Fill voids caused by excavation of unsuitable material with Granular Material in areas where structures, foundations, or slabs will be constructed.
- F. Compaction Around Structures.
1. Mechanically compact.
 - a. Use platform type tampers or similar equipment.
 - b. Rolling is permitted provided proper compaction is obtained and adequate measures are taken to prevent damage to structures.
 2. Do not backfill against new concrete walls less than 14 days after removal of forms.
 - a. Do not exceed ten (10) foot heights with backfill in less than 21 days after removal of forms.
- G. Compaction Equipment.
1. Use equipment suited to the soil being compacted.
 2. Sheepfoot Roller: If used, provide with cleaner bars so attached as to prevent the accumulation of material between the tamper feet.
 3. Rollers: designed so that the effective weight can be increased.
- H. Rock and bedrock encountered in the excavation shall be separated from other excavated material and disposed of by CONTRACTOR.
- I. Do not compact by use of water flooding or jetting.

3.5 TRENCHING

- A. Excavate trenches by open cut methods.
1. Provide adequate subgrade clearance for pipe bells and for compaction of bedding material under the bells and pipe.
 2. Do not allow bells or fittings to support or be in contact with the trench subgrade or walls. Provide a minimum of 3 inches bedding material beneath bells and fittings.
 3. Pipelines in fill areas: excavate trenches after fill has been placed and compacted.
- B. Do not use mechanical equipment in locations where its operation would cause damage to trees, culverts, or other property, utilities, or structures above or below ground. In all such locations, hand excavating methods shall be used.

- C. Use mechanical equipment so designed and operated that the rough trench excavation bottom elevation can be controlled with uniform trench widths and vertical sidewalls from an elevation one (1) foot above the top of the installed pipe to the bottom of the trench, and trench alignment sufficiently accurate to permit pipe to be aligned properly with adequate clearance between the pipe and sidewalls of the trench. Do not undercut the trench sidewall to obtain clearance.
- D. Excavation in Rock.
 - 1. Over excavate a minimum of six (6) inches below the bottom of the pipe.
 - 2. Backfill with Granular Material.
- E. Preparation of Trench Bottom.
 - 1. Grade trench bottoms uniformly to provide clearance for each section of pipe.
 - 2. Remove loose materials, water and foreign objects.
 - 3. Provide firm subgrade suitable for application of the bedding material.
 - 4. Wherever unstable material is encountered in the bottom of the trench,
 - a. Over-excavate such material to a depth suitable for construction of a stable subgrade.
 - b. Backfill over-depth with Stabilization Material and compact.
- F. Limiting Trench Widths.
 - 1. Excavate trenches to a width necessary to provide 18 inch minimum working space between pipe and trench wall for proper pipe installation, jointing and bedding.

3.6 PIPE BEDDING

- A. Bedding classes. Place pipe bedding in accordance with the details shown on the Drawings. Provide higher class bedding where maximum trench width or maximum depths are exceeded or unexpected trench conditions are encountered and a higher class is required to avoid overloading the strength of pipe being placed as determined by ENGINEER. CONTRACTOR may elect to use a higher class pipe in lieu of a higher class bedding.
- B. Placement and Compaction.
 - 1. Distribute and level bedding material to provide uniform and continuous support beneath the pipe at all points between bell holes or pipe joints.
 - 2. Deposit bedding material and compact uniformly and simultaneously on each side of the pipe to prevent lateral displacement.

3. Compact Granular bedding material by vibrating, slicing with a shovel or bent tee-bar.
- C. Overdepth Excavation.
 1. Restore overexcavated subgrades to proper elevation with Stabilization Material.
 - D. Ground Water Barriers.
 1. To impede passage of water through bedding material, construct a ground water barrier the full trench width, four feet long, and from the bottom of all Granular Material to the top of all Granular Material.
 2. Locations.
 - a. Approximately 10 feet downstream from each manhole.
 - b. 20 feet outside of structures and slabs and spaced not more than 400 feet apart.
 - c. At the midpoint of piping crossing the embankments. Every 400 feet for piping paralleling the top of the embankments.
 - d. One groundwater barrier is a minimum on all piping using Granular Bedding Material.

3.7 TRENCH BACKFILL

- A. Backfill trench properly after completion of pipe bedding.
- B. Use Granular Material to top of trench for all piping beneath concrete structures and concrete slabs.
- C. Where trench for one (1) pipe passes beneath trench for another pipe, backfill and compact the lower trench to the bottom of the upper trench using Granular Bedding Material trench backfill prior to installation of the pipe in the upper trench.
- D. Deposit backfill material in uniform layers not exceeding eight (8) inches in uncompacted thickness. Increased layer thickness may be acceptable provided it is demonstrated that the specified compacted density will be obtained.
- E. Use methods and equipment appropriate for the backfill material. Do not use equipment or methods that will transmit damaging shocks to the pipe.
 1. Do not perform compaction by jetting or flooding.
- F. Import trench backfill material for trench backfill if compaction can not be obtained with job excavated material.

3.8 SHEETING AND SHORING

- A. If steel sheet piling is required, piling shall be driven to form a tight bulkhead. A driving head shall be used and any piling which is damaged in driving shall be pulled and replaced.
- B. If splicing is required; splicing will be limited to three (3) per pile sheet and jointed with a full penetration butt weld.
- C. Sheeting Removal.
 - 1. Do not remove sheeting prior to backfilling.
 - 2. Use effective methods to protect the construction, other structures, utilities and properties during sheeting removal.
 - 3. Fill voids left by sheeting removal with dry sand.
 - 4. Sheeting which is left in place shall be cut off at an elevation 2 feet below the finish grade of unpaved areas, or the subgrade of paved areas.
- D. Trench boxes may be used as an alternate to steel sheet shoring.
- E. If shoring is removed or trench boxes are used, provide secondary trench boxes to protect all parties entering trenches at all locations other than where shoring or primary trench boxes are located.

3.9 FINISH GRADING

- A. Grade all areas after structures, trenching, backfills, and fills have been completed to slopes, contours or elevations indicated on the Drawings. Compact with uniform levels or slopes between points where elevations are shown.
 - 1. Shape the surface of areas under slabs to line, grade and cross section, with the finish surface not more than 0.00' above or 0.10' below the required subgrade elevation, compacted as specified, and graded to prevent ponding of water.
 - 2. Shape the surface of the areas under pavement surface not more than 1/4" above or 1/2" below the required subgrade elevation. Grade to prevent ponding of water where feasible.
 - 3. Existing contours shall be mimicked to the extent possible which may result in ponded areas.
- B. Finish ditches and grading to ensure proper positive flow and drainage. Conduct final rolling operations to produce a hard, uniform and smooth cross-section. Provide effective drainage with slopes of at least one (1) percent unless otherwise indicated.

3.10 FIELD QUALITY CONTROL

- A. Field Compaction Control.
 - 1. Field tests will be conducted by OWNER to determine compliance of compaction methods with specified density in accordance with:

- a. ASTM D2922 (AASHTO T238) - Tests for Density of Soil and Soil - Aggregate In-Place by Nuclear Methods, or
 - b. ASTM D1556 (AASHTO T191) - Tests for Density of Soil In-Place by the Sand Cone Method, or
 - c. ASTM D2167 (AASHTO T205) - Tests for Density of Soil In-Place by Rubber-Balloon Method.
- B. Compaction shall be to the following minimum densities, reference ASTM D698 or AASHTO T99 unless otherwise indicated:
- 1. Subgrade under pipe, footings, foundations, structures and slabs: 95%
 - 2. Structural backfill: 95%
 - 3. Fills and embankments.
 - a. Under slabs or pavement areas: 95%
 - b. Open areas: 90%
 - 4. Pipe bedding.
 - a. Carefully compacted select soil: 90%
 - b. Compacted Granular Material: 80% (ASTM D4253, D4254)
 - 5. Trench backfill.
 - a. Under footings, foundations, structures, pavement, slabs, and sidewalks (full depth): 95%
 - b. Upper 4 feet: 95%
 - c. Below upper 4 feet: 90%
 - 6. Granular Material: 80% (ASTM D4253, D4254)
 - 7. Seeded areas: 88% top 18 inches
 - 8. All other areas 95%
 - 9. Where granular materials are used in lieu of cohesive soils reduce the above percentages by 15% for select soils to arrive at the relative density and ASTM D4253 and D4254 shall apply.
- C. Moisture Content.
- 1. Compact non-clay materials within 2% (+/-) of the optimum moisture content of the soil, compact clay materials at optimum moisture to 4% above optimum moisture as determined by ATSM D698.
 - 2. Water shall be added to the material, or the material shall be harrowed, disced, bladed, or otherwise worked to insure uniform moisture content, as specified.

3.11 COMPACTION TEST FAILURE

- A. If the required state of compaction is not obtained, it shall be the responsibility of the CONTRACTOR to re-compact the material to the required state of compaction. The OWNER may require that the backfill be removed and re-compact or replaced.

END OF SECTION

SECTION 02315

STEEL CASING PIPE

PART 1 - GENERAL

1.1 REQUIREMENTS

- A. This section specifies minimum design and performance requirements for steel casing pipe installed using trenchless construction tunneling methods.
- B. Furnish all designs, tools, equipment, materials, and supplies and perform all labor required to complete the Work as indicated on the Contract Documents and specified herein.

1.2 REFERENCE SPECIFICATIONS, CODES, AND STANDARDS

- A. Comply with the applicable Specifications:
 - 1. General Conditions
 - 2. Section 02316, Pipe Ramming
 - 3. Section 02440, Pipe Jacking
 - 4. Section 02623, Microtunneling
 - 5. Section 02715, Carrier Pipe Installation into Casing
 - 6. Section 03355, Backfill Grout
 - 7. Section 03360, Contact Grouting
 - 8. Section 15064, HDPE Pipe
- B. Comply with the following industry standards effective at time of bid:
 - 1. ASTM A36 – Standard Specification for Carbon Structural Steel
 - 2. ASTM A53 – Standard Specification for Pipe, Steel, Black and Hot-Dipped, Zinc-Coated, Welded and Seamless.
 - 3. ASTM A139 – Standard Specification for Electric-Fusion (Arc)-Welded Steel Pipe – Grade B
 - 4. ASTM A515 - Standard Specification for Pressure Vessel Plates, Carbon Steel, for Intermediate- and Higher-Temperature Service – Grade 60.
 - 5. ASTM A572, Grade 42 - Standard Specification for High-Strength Low-Alloy Columbium-Vanadium Structural Steel

6. ANSI/AWS D1.1 – Structural Welding Code - Steel

1.3 CONTRACTOR SUBMITTALS

- A. Submittals shall be made in accordance with General Conditions and as specified herein.
- B. Submittals shall be coordinated with all relevant submittals, assembled and submitted as a single, comprehensive submittal.
- C. Where calculations are required to be submitted, they shall be signed and sealed by a Professional Civil Engineer registered in the State of Colorado. Calculations shall clearly identify all parameters used, state all assumptions made in the calculation, and identify all sources of information.
- D. All shop drawings shall be legible with dimensions accurately shown and clearly marked in English units.
- E. Pre-Construction Submittals:
 - 1. Calculations demonstrating that the casing pipe selected by the Contractor has been designed to support the maximum anticipated earth loads, superimposed live loads, jacking forces, buoyancy, and handling loads that may be imposed on the pipe. The Contractor shall determine the additional stresses imposed on the pipe during jacking operations and upgrade the quality and strength of the pipe and pipe joints to the extent necessary to withstand the additional stresses imposed by the jacking operation with a factor of safety of at least 2.5.
 - 2. Submit manufacturer's mill specification sheet listing diameter, thickness, and class of steel used in making the casing, and the mill certification.
 - 3. Submit a certificate of compliance that verifies the pipe complies with the project specifications, including pipe design data, and tolerances.
 - 4. Submit shop drawings of casing showing grout and port location, size are required for casing 60 inch diameter and larger.
 - 5. Submit shop drawings showing lay length and joint detail.
 - 6. Submit manufacturer's pipe shipping, handling, storage and assembly instructions.
 - 7. Submit the pipe manufacturer's recommendations for joint connections, repairs for joint failures and repairs for sidewall failure.
 - 8. Welder qualifications and welding certifications if welded casing pipe is submitted. All welding procedures used to fabricate steel casings shall be prequalified under the provisions of ANSI/AWS D1.1. All welding shall be performed by skilled welders, welding operators and tackers who have had adequate experience in the type of materials to be used. Welders shall be qualified under the provisions of ANSI/AWS D1.1 by an independent local, approved testing agency not more than six (6) months

prior to commencing work on the casing.

9. Qualifications of an independent pipe fitter.

PART 2 - PRODUCTS

- A. Provide casing with a circular shape and flush outside surface with minimum inside diameter as shown on the Contract Drawings. Steel casing pipe shall have a smooth wall and shall conform to A.S.T.M. Designation A139, Grade B structural with a minimum yield strength of 36,000 psi. Casing pipe joints shall be beveled for field butt welding. Steel casing pipe minimum wall thickness of 0.75" and shall be fabricated in accordance with AWWA C-200.
- B. The Contractor may elect to adjust the excavated diameter and / or casing diameter to fit their means and methods. The Contractor shall provide written justification for review and acceptance of the Engineer for the adjustment of the excavated diameter or the casing diameter.
- C. The strength of the pipe and joints must be sufficient to withstand both the installation loads and the in-place, long-term service loads. Contractor shall be responsible to increase plate thickness to accommodate the construction load.
- D. Provide casing that is specifically manufactured for trenchless construction with a smooth outer wall and is manufactured to the following dimensional criteria:
 - 1. Circumference < 0.5%
 - 2. Exterior Roundness < 0.5%
 - 3. End Squareness +/- 0.1 inch
 - 4. Straightness < 0.1 inch
 - 5. Pipe Length +/- 0.2 inch
 - 6. Casing lengths shall be nominal
- E. Joints must be capable of watertight performance for internal operating pressures (including working and transient pressures, and external head pressure resulting from groundwater, slurry pressures, and lubrication. The joint must be capable of efficiently transferring jacking forces from the hydraulic jacking frame, through the pipe wall and joint, to the trenchless face.
- F. All casing segments shall be joined by continuous, full circumference, full penetration butt welds or Permalok™ joint as manufactured by Permalock of St. Louis, MO. If mechanical press-fit joint such as Permalock is used, conform to manufacturer's recommendation.
- G. For 60 in diameter casing or larger, provide 2 in grout connections regularly spaced at a minimum of 5 ft on center alternating at 30 degrees from plumb each side of the vertical centerline.

PART 3 - EXECUTION

- A. Casing pipe installation shall be in accordance with Section 02316, Pipe Ramming, 02440 Pipe Jacking, or 02623, Microtunneling.

****END OF SECTION****

SECTION 02316

PIPE RAMMING

PART 1 GENERAL

1.1 REQUIREMENTS

- A. This section specifies minimum design and performance requirements for the construction of a steel casing pipe, to house a gravity operated effluent pipeline, constructed using pipe ramming.
- B. Furnish all designs, tools, equipment, materials, and supplies and perform all labor required to complete the Work as indicated on the Contract Drawings and specified herein.
- C. Select, furnish, and maintain the pipe ramming and associated equipment in proper and safe working order.

1.2 REFERENCE SPECIFICATIONS, CODES, AND STANDARDS

- A. Comply with the applicable reference Specifications:
 - 1. Section 01130, Dewatering
 - 2. Section 01340, Contractors Shop Drawings
 - 3. Section 01700, Contract Closeout
 - 4. Section 02300, Earthwork and Trenching
 - 5. Section 02315, Steel Casing Pipe
 - 6. Section 02445, Instrumentation and Monitoring
 - 7. Section 02621, Shaft Construction
 - 8. Section 02715, Carrier Pipe Installation into Casing
 - 9. Section 03360, Contact Grout
- B. Comply with the following industry standards effective at time of bid:
 - 1. NFPA 241 – Standard for Safeguarding Construction, Alteration, and Demolition Operations.

1.3 DEFINITIONS

- A. Annular Space (Annulus): The theoretical volume created by the radial distance between the largest outside radius allowed in the tolerance of the jacking pipe and the outside diameter of the pipe ramming leading edge over the length of the installation.
- B. Carrier Pipe: For this project, pipe for conveyance of treated effluent.

- C. Casing: A jacking pipe which supports a bore. The casing is not a carrier pipe. The carrier pipe is constructed within the casing.
- D. Contact Grouting: Grouting outside of the jacking pipe to fill the annular space and voids and to assure that intimate contact for load transfer between the jacking pipe and the native host material has been achieved.
- E. Dewatering: The act of removing groundwater for lowering the groundwater elevation using a system of wells and pumps.
- F. Down Time: Time lost when the pipe ramming equipment is unable to operate; generally associated with equipment failure.
- G. Drive: Designation of the jacking pipe installed from a jacking shaft to a reception shaft.
- H. Entrance/Launch Seal: A mechanical seal, usually comprised of a rubber flange that is mounted to the wall of the jacking shaft. The flange seal is distended by the leading edge as it passes through, creating a seal to prevent lubrication inflow into the shaft during tunneling operations.
- I. Exit Seal: Same as launch seal except for the retrieval of the equipment at the reception shaft. Used in high groundwater and unstable soil to prevent ground loss.
- J. Exit Shaft: See Reception Shaft
- K. Face: the location where excavation is taking place.
- L. Face Pressure: Earth and groundwater pressures applied against the cross sectional area of the pipe ramming leading edge
- M. Factor of Safety: A ratio between the structural capacity of a system divided by expected loads or actual loads.
- N. Grouting: The process of filling voids or modifying/improving ground conditions. Grouting materials may be cementitious, chemical, or other mixtures.
- O. Heave: Measurable upward movement of the ground or structure as the result of the excavation process.
- P. Jacking Force: The total force required to overcome the face pressure component and frictional resistance component along the pipe string to allow the forward movement of the pipe string.
- Q. Jacking Loads: See Jacking Force.
- R. Jacking Pipe: Pipe designed to be installed using pipe jacking techniques.

- S. Jacking/Launch Shaft: Excavation from which trenchless technology equipment is launched for the installation of a pipeline. The jacking/launch shaft may incorporate a thrust wall to spread reaction loads to the ground and an entry ring to control inflows of groundwater and ground at the portal.
- T. Inadvertent Returns: The loss of lubrication from lubrication system. A special form of inadvertent return, where the fluid exceeds the strength and confining pressure of the ground and reaches the surface or waterway, is called a hydrofracture or “frac-out.”
- U. Leading Edge: The first segment of the pipe string as the casing is advanced, usually either a pre-fabricated soil-cutting shoe or a special band welded around the jacking pipe.
- V. Lubrication: The act of injecting a fluid, normally bentonite and/or polymers, used to reduce the skin friction and jacking forces on the jacking pipe during installation. The fluid fills the annular space.
- W. Maximum Allowable Jacking Force: The largest jacking force that can be applied to the jacked pipe, allowing for an appropriate factor of safety.
- X. Maximum Anticipated Jacking Force: The largest anticipated jacking force required to advance jacking pipe along a drive.
- Y. Obstruction: Any buried object that lies completely or partially within the cross-section of the face and prevents continued forward progress along the design path and allowable tolerances after diligent efforts by the Contractor.
- Z. Pipe Jacking: A system of directly installing jacking pipes behind a shield machine by hydraulic jacking from a jacking shaft such that the joined pipe segments form a continuous string in the ground.
- AA. Pipe Ramming: a trenchless construction method which involves driving a casing pipe along a predetermined alignment using a pneumatically-powered ramming device. Spoils are collected inside the casing pipe during the ramming process, creating a soil plug inside the pipe. At intervals during the installation or upon completion of the installation, the spoils are removed from inside the casing pipe using a screw auger.
- BB. Pipe Lubricant: See Lubrication.
- CC. Pipe String: The succession of joined individual jacking pipe segments being used to advance and support the excavation.
- DD. Pre-Treated Ground: Grouted or otherwise stabilized ground used to prevent ground deformation or inflows, or to stabilize existing features.
- EE. Product Pipe: See Carrier Pipe

- FF. Reception/Exit Shaft: Excavation into which the pipe ramming equipment is driven and recovered.
- GG. Settlement: Measurable downward movement of the ground, overlying utility, or other structure as the result of the excavation process or dewatering.
- HH. Spoil: Earth, rock, and other materials excavated during the microtunneling process.
- II. Surface Settlement Points: Survey control points established at the ground surface along the pipe alignment for monitoring surface movement resulting from subsurface excavation.
- JJ. Zone of Influence: Volume of ground that could possibly be impacted by settlement or heave from either the pipe ramming, shaft excavation, pile driving, or other construction activities.

1.4 DESIGN REQUIREMENTS

- A. CONTRACTOR may adjust the excavated diameter to fit their means and methods as long as the selected diameter enables the installation of the carrier pipe in accordance with Section 02715.
- B. Provide the maximum anticipated earth loads, live loads, including HS-20 loads, jacking loads and handling loads that might be imposed on the casing pipe, and ensure that anticipated loads are incorporated into the manufacturer's design of the casing pipe subject to the ENGINEER's review.
- C. As a minimum, provide pneumatic hammer capacity that exceeds the maximum required capacity by at least 20 percent as sized by the manufacturer or CONTRACTOR's engineer.
- D. As a minimum provide air compressor(s) that exceed the maximum operating air capacity as recommended by the manufacturer of the selected hammer as measured in air pressure and cubic feet per minute (cfm).
- E. As a minimum provide electric generator capacity that exceeds the maximum required capacity of the selected air compressor(s) and ancillary equipment by at least 20 percent.

1.5 PERFORMANCE REQUIREMENTS

- A. Ground movement on the surface directly above the pipeline shall not exceed that specified in Sections 02445.
- B. Install the casing pipe within the following line and grade tolerances:
 - 1. Horizontal tolerance: Plus or minus 0.50 feet (6.0 inches) of theoretical centerline of the carrier pipe.

2. Vertical tolerance: Plus or minus 1.0 feet (12.0 inches) of the theoretical centerline of the carrier pipe.

1.6 QUALITY ASSURANCE

- A. Requirements outlined below shall be met at the time of bid and remain in force through completion of the project. Subcontracted work does not qualify as experience.

1. The CONTRACTOR performing the pipe ramming work shall have at least six (6) years of experience in performing pipe ramming and shall have successfully completed:

- a. Three (3) pipe ramming projects installing casing pipe with an outside diameter of 60 inches or greater.
- b. Three (3) pipe ramming projects using the same type of casing pipe material as specified for this project.
- c. Two (2) pipe ramming projects in similar ground conditions as measured by soil type, N value and hydrostatic head, as anticipated on this project, with a drive length of at least 90 feet on each project.

2. Pipe Ramming Project Superintendent shall have:

- a. A minimum of five (5) years of experience in the installation of pipes using pipe ramming.
- b. A minimum of three (3) projects, with each project consisting of at least 250 feet of pipe installed using pipe ramming.
- c. Successfully completed two (2) pipe ramming projects installing casing pipe with an outside diameter of 60 inches or greater.
- d. Successfully completed two (2) pipe ramming projects using the same type of casing pipe material as specified for this project.
- e. Successfully completed two (2) pipe ramming projects in similar ground conditions as measured by soil type, N value, and hydrostatic head, as anticipated on this project.

3. Operator shall have:

- a. A minimum of five (5) years of experience in the installation of pipes using pipe ramming.
- b. A minimum of three (3) projects, with each project consisting of at least 250 feet of pipe installed using pipe ramming.
- c. Successfully completed two (2) pipe ramming projects installing casing pipe with an outside diameter of 60 inches or greater.
- d. Successfully completed two (2) pipe ramming projects installing the same type of casing pipe material as specified for this project.
- e. Successfully completed two (2) pipe ramming projects in similar ground conditions as measured by soil type, N-value, and hydrostatic head, as anticipated on this project.
- f. Operated pipe ramming equipment similar to the one proposed on this project.

4. Pipe ramming engineer shall be a Professional Engineer registered in the State of Colorado. Experience shall include pipe ramming design calculations on five (5) projects within the last five (5) years.
5. Lubrication Specialist shall have:
 - a. A minimum of five (5) years of experience in the design of lubrication mixes based on anticipated ground conditions and modifications based on field conditions.
 - b. A minimum of five (5) projects, with each project consisting of at least 90 feet of pipe installed using pipe ramming.
 - c. Successfully completed two (2) pipe ramming projects installing casing pipe with an outside diameter of 60 inches or greater.
 - d. Successfully completed two (2) pipe ramming projects in similar ground conditions as measured by soil type, N-value, and hydrostatic head, as anticipated on this project.
 - e. Performed lubrication testing as specified herein.
6. Surveyor shall be a Professional Land Surveyor registered in the State of Colorado with experience in underground surveying. Experience shall include:
 - a. Three (3) tunnel projects within the last eight (8) years,
 - b. Transfer of points and line from the surface to below ground,
 - c. Closed loop tunnel survey for line and grade.
7. Experience records shall list the five (5) most recent pipe ramming projects, including all pipe ramming projects completed for the OWNER, and all projects demonstrating the specified experience. The experience record shall include name of project; owner of the project; names of contacts including all contact information; casing pipe material used; casing pipe outside diameter; ground conditions as measured by soil type, N value, and hydrostatic head; longest drive planned and completed; and total footage planned and completed.
8. The ENGINEER will be the sole judge in determining if the prospective pipe ramming contractor, project superintendent, operator and surveyor meet the aforementioned work and project experience requirements.

B. Surveying:

1. Establish control points sufficiently far from the pipe alignment so as not to be affected by ground movement or damaged by any Work on the project.

1.7 CONTRACTOR SUBMITTALS

- A. Submittals shall be made in accordance with the General Conditions and as specified herein.
- B. Pipe ramming submittals shall be coordinated with all relevant submittals, assembled and submitted as a single, comprehensive submittal.

- C. Where calculations are required to be submitted, they shall be signed and sealed by a Professional Civil Engineer registered in the State of Colorado. Calculations shall clearly identify all parameters used, state all assumptions made in the calculation, and identify all sources of information.
- D. All shop drawings shall be legible with dimensions accurately shown and clearly marked in English.
- E. Pre-Construction Submittals:
 - 1. Submit a schedule for all pipe ramming operations. Schedule shall be coordinated with overall schedule for the Contract.
 - 2. Submit qualifications and experience records for the following:
 - a. Pipe ramming contractor performing the Work;
 - b. Pipe ramming project superintendent;
 - c. Operator;
 - d. CONTRACTOR's Engineer; and
 - e. CONTRACTOR's Surveyor.
 - 3. Manufacturer's preprinted data sheets and specifications for the pipe ramming equipment.
 - 4. Layout of jacking and receiving shaft sites showing all major equipment including electrical equipment, pneumatic hammer, pipe storage, pipe lifting crane etc.
 - 5. Shop drawing showing leading edge treatment details.
 - 6. Shop drawing showing trailing edge to ramming equipment connection details.
 - 7. Calculation of Maximum Anticipated Jacking Force. Identify source of equation, source of friction factor, and the factor of safety. Equation and factors shall be from a widely accepted industry source acceptable to the ENGINEER.
 - 8. Calculations of maximum anticipated earth loads, live loads, operational loads and construction loads that might act on the casing pipe, including BNSF E80 loads. Calculations are to verify that casing pipe will withstand the maximum anticipated loads with a minimum factor of safety of 2.0.
 - 9. Method of setting the pipe segments to design line and grade in the jacking shaft.
 - 10. Method of maintaining the line and grade of the casing pipe within design tolerances during pipe ramming.
 - 11. Method of preventing the maximum allowable jacking load to be exerted on the casing pipe.
 - 12. Launch procedure details.

13. Plan and details showing an artificial plug of sand bags or alternative; and a well point located forward of the plug, inside the casing to dewater the incoming soils. Provide details for any other measures taken to prevent ground and groundwater from entering shaft.
14. Description of lubrication system, including capacity, operating parameters and procedures:
 - a. Description of lubrication mixing equipment and procedure for lubricating the pipe during ramming operations, including estimated volume for the anticipated ground conditions.
 - b. Proposed design mix including proportions, water quality, and pH.
 - c. Identify pressure gauge and volumetric gauge locations.
15. Method of spoil removal and measuring the volume of excavated material, if applicable.
16. Provide a sample of the daily progress report and manual jacking log.
17. Shaft ventilation system details including fan size and operating parameters.
18. Electrical system, lighting system, and onsite power generation details.
19. Contingency Plans addressing the following:
 - a. Line and/or grade tolerance is exceeded.
 - b. Launch and reception plan that addresses steps to be taken in case of ground and/or groundwater entering shaft during launch or reception.
 - c. Obstruction removal plan with observational and operational characteristics that indicate an obstruction is encountered.
 - d. Jacking pipe failure plan with inspection, repair, and removal plans. Repair methods shall be acceptable to the pipe manufacturer and the ENGINEER.
 - e. Excessive ground movement plan including means and methods of expeditiously restoring any excessive ground settlement, with special respect to the BNSF right-of-way.
 - f. If lubrication is used, provide inadvertent returns plan with cleanup methods; emergency telephone numbers; sources of equipment and materials needed for containment and clean-up; and corrective actions for reducing operating pressures and modifying lubricant. Lubrication inadvertent return plan shall include operating parameters that are controlled with the intent of preventing an inadvertent return.

- g. Excavated ground volume exceeds tolerances on theoretical volume, if applicable.
 - h. Noticeable hydrocarbon smell is detected in shaft.
- F. Construction Submittals:
1. Notifications:
 - a. All notifications are to be provided in writing and within one work day unless otherwise specified herein.
 - b. Immediately notify the ENGINEER upon encountering an object that impedes the forward movement of the pipe string.
 - c. Immediately notify the ENGINEER upon implementation of any contingency plan.
 2. Provide daily progress reports with the following information for each shift:
 - a. Date.
 - b. Project name.
 - c. Start and finish times for each crew.
 - d. Printed name of operator and signature.
 - e. Number of each pipe segment installed and length of pipe.
 - f. Start and end time for each pipe segment.
 - g. Location of pipe by station at the start and end of shift.
 - h. Observations of settlement and heave.
 3. Provide manual jacking log with a recording points of measurements at every five (5) feet of advance. Record the following measurements and provide unit of measure:
 - a. Name of person taking the measurement.
 - b. Time of measurement.
 - c. Pipe number.
 - d. Location of pipe by station.
 - e. Frequency of hammering.
 - f. Jacking pressure.
 4. Provide contemporaneous log of all line and grade checks. Log shall include:
 - a. Date, time, pipe number, and person making adjustment.
 - b. Measurements immediately before adjustment.
 - c. Measurements immediately after adjustment.
 - d. Survey data if adjustment is performed based upon survey data.
 - e. Daily verification of design slope and person making verification.
 5. Lubrication log sheet including date, shift, lubrication specialist, number of batches mixed, mix properties including pH, density, viscosity and gel strength.

6. Provide all manual and automated records and logs by 9 AM the following work day. Provide hard copy and electronic copy of automated records in formats acceptable to the ENGINEER.
 7. Survey data:
 - a. Survey of line and grade for pipe ramming operations.
 - b. Submit readings to the ENGINEER on the same work day the readings are taken.
 - c. Provide interpretation of survey results to the ENGINEER on the following work day.
 - d. Provide copies of field forms used to establish all lines and grades.
- G. Post-Construction Submittals:
1. Provide as-built survey of the casing pipe. Provide results in both tabular format and AutoCAD format acceptable to the ENGINEER. Scale to be acceptable to the ENGINEER. Survey shall confirm that carrier pipe can be installed within design tolerances.

1.8 PROJECT/SITE CONDITIONS

- A. For geotechnical information refer to "Geological Hazards and Geotechnical Investigation Persigo Wastewater Treatment Plant Outfall Grand Junction, Colorado, Project # 01543-0001 dated October 10, 2017.
- B. Site specific data:
 1. Test Pit TP-1 as reported in the Geological Hazards and Geotechnical Investigation Persigo Wastewater Treatment Plant Outfall was dug in September of 2017 to a depth of 13 feet in the center median of I-70. Material in TP-1 was Gravelly Clay with Cobbles to Clayey Sand with Gravel for the first 5 feet with Sandy Gravel and Cobbles below 5 feet. Cobble sizes of up to 12 inches were observed. The material exhibited characteristics of flowing, non-cohesive, non-plastic soils in accordance with the Tunnelmans Ground Classification. Groundwater was observed at a depth of 9 feet. Surface elevation is approximately 4514 above mean sea level.
 2. Test Pit TP-2 as reported in the Geological Hazards and Geotechnical Investigation Persigo Wastewater Treatment Plant Outfall was dug in September of 2017 to a depth of 10 feet approximately 20 feet north of westbound of I-70 at a location approximately equal to the receiving shaft. Material in TP-2 was Clayey Sand with organics for the first 2 feet where it transitioned to Clayey Sand with gravel to a depth of 7 feet. Below that elevation was observed to be Sandy Gravel and Cobbles. Cobble sizes of up to 12 inches were observed. The material exhibited characteristics of flowing, non-cohesive, non-plastic soils in accordance with the Tunnelmans Ground Classification.

Groundwater was observed at a depth of 8 feet. Surface elevation is approximately 4514 above mean sea level.

- C. For baseline purposes, the anticipated ground conditions along the trenchless alignment indicated on the Contract Drawings are baselined as the following.
1. Soils at the proposed horizon of the trenchless alignment will consist of flowing to running ground, non-cohesive sandy gravel and cobbles (GP)
 2. Full face of non-cohesive materials that will fast ravel and flow when not adequately supported at the face.
 3. Granular materials will be encountered during the launching, receiving and tunnel excavation. Direct communication with the Colorado River and nearby tributaries will exhibit flowing behavior when not adequately supported or dewatered.
 4. The relative percentage of non-cohesive materials such as sand, gravel and cobbles will be more than 95% within the tunnel zone.
 5. Cobbles, as defined ASTM D2487 – USCS, are the coarsest material to be encountered during excavation along the alignment shown on the Contract Drawings. Nested cobbles are expected along the tunnel alignment.
 6. Non-cohesive materials will cause excessive abrasion and wear to the tooling used for excavation.
 7. Approximately 5% or less fines are to be encountered along the within the tunnel zone.
 8. The upper five (5.0) feet of ground cover shall be assumed to be artificial fill material. Asphalt and aggregate are anticipated under the Interstate 70. A maximum of 30% of the bank volume of the excavated fill material will contain cobble-sized material.
 9. As stated in the Geotechnical Exploration Report, groundwater level varies along this alignment. The groundwater is influenced by the water surface in the Colorado River and may be higher or lower during construction.
 10. For design purposes, groundwater levels will be at Elevation 4510 feet prior to be dewatering to allow for potential raised elevations.
- D. Engineered fill of unknown character, material, and engineering properties, may be present beneath the I-70 embankment to an

unknown depth. For design purposes, soils at launch and reception shaft and within the proposed trenchless horizon, will be native. The optional intermediate shaft will contain approximately 5 to 8 feet of artificial fill.

PART 2 PRODUCTS

2.1 MATERIALS

A. Casing Pipe

1. Provide casing pipe in accordance with Section 02315
2. Provide casing pipe that is specifically manufactured for pipe ramming.

B. Lubrication, if used, shall consist of:

1. High yield sodium bentonite.
2. Potable water.
3. Test all water for pH and treat with soda ash, or approved equal, to adjust the pH of the water as required in the accepted mix design(s).
4. Bentonite, polymers, and additives, other than soda ash, shall be NSF/ANSI Standard 060 compliant.

C. Hydraulic fluids shall be fire resistant, in accordance with NFPA 241.

2.2 EQUIPMENT

- A. Provide ramming equipment capable of jacking the casing pipe through the anticipated ground conditions and any ground pre-treatment.
- B. Provide pneumatically operated driving hammer of adequate capacity to ensure uniform advancement without over-stressing of the pipe.
- C. Provide for control to ensure that the Maximum Allowable Jacking Force will not be exceeded at all times.
- D. Provide a lubrication system that is used at all times if lubrication is used in the jacking force calculations.
- E. Ramming equipment shall be a mono-bloc design with rear cushion and Teflon slide seals, no bolts or threaded connections.
- F. Hammer to steel casing engagement connection shall be solid segmented ram cones (collets) and tapered locking ram cones. No steel casing reducing adaptor shall be used.

PART 3 EXECUTION

3.1 GENERAL

- A. Perform all work in accordance with accepted submittals.
- B. Perform work in conformance with CDOT requirements.
- C. Do not commence any pipe ramming operation until all submittals, including submittals for all related work specified elsewhere, are reviewed and accepted by the ENGINEER.
- D. Maintain a copy of the Contract Documents on site at a location acceptable to the Engineer and accessible to the operator.
- E. Provide the ENGINEER and OWNER with access to the shaft and operations control instrumentation at all times during pipe ramming operations.
- F. Treat and dispose of all water in accordance with the requirements specified in Section 01130.
- G. No excavation deeper than four (4.0) feet shall be permitted within 100 feet of the pipe ramming alignment during pipe ramming operations, except the installation of instrumentation as specified in Section 02445.
- H. Locate all utilities in accordance with Section 02624 before commencing pipe ramming.
- I. Protect in-place or relocate existing utility. Remove and replace in-kind any damaged utility.
- J. Use sand bags or equivalent inside of the casing to create an artificial plug against inflow of ground.
- K. Install well point in front of artificial plug to dewater the incoming soils.

3.2 WORK AREA PREPARATION AND MAINTENANCE

- A. Organize pipe ramming equipment in such a manner as to enable proper operation at all times, to minimize impacts to property owners.
- B. Provide a suitable containment basins made of plastic lining and sand bags for any equipment operating with fuel, hydraulic, or lubrication oils.
- C. Maintain and keep all equipment in proper working order. All oil, hydraulic, or fuel leaks shall be repaired immediately upon discovery. Any leaking equipment shall not be used until repaired. Any fluid shall be contained and cleaned up upon discovery. Provide written notification within 4 hours of discovery.

- D. Contain all lubricant spills upon discovery and clean up and dispose of spills properly. Provide written notification within 4 hours of discovery.
- E. Provide temporary drainage facilities during construction.

3.3 INSTALLATION

A. Alignment Establishment:

1. Perform surveying as specified herein.
2. Contractor's surveyor shall check line and grade shown on the Contract Drawings before commencing pipe ramming operations and immediately report any errors or discrepancies to the ENGINEER.
3. Use the line and grade shown on the Contract Drawings to furnish and maintain reference control lines and grades for the sewer pipeline construction.

B. Obstructions during pipe ramming:

1. Remove, clear, or otherwise make it possible for the pipe to progress past or through an object in accordance with the submitted contingency plan.
2. The proposal of alternative methods for removing, clearing, or otherwise making it possible for the pipe to progress past an object that does not allow for the direct observation and measurement of the object shall not be considered for additional payment.
3. If it is not possible to advance the pipe past the obstruction, pipe shall be abandoned and a new alignment started, subject to acceptance by the ENGINEER. End of abandoned pipe shall be plugged with a minimum 12 inches thick masonry plug, brick and mortar plug or end seal. Pipe abandonment and replacement shall in no way result in extra cost to the City.

C. All excavated material from tunnel construction shall be disposed of in accordance with Section 02300.

D. Perform contact grouting in accordance with Section 03360 along the full length of the casing pipe, if needed.

3.4 SITE RESTORATION

- A. Remove all equipment, materials, muck, waste, and debris from the site and restore the site to its original condition upon completion of the installation. Restoration shall be completed by the Contractor as specified within Section 02300. Restore disturbed areas in accordance with Section 01700.

END OF SECTION

SECTION 02356

STEEL SHEET PILING

PART 1 - GENERAL

1.1 PROJECT REQUIREMENTS

- A. This section specifies the requirements for excavating, sheeting, and shoring required to construct jacking and receiving shafts for trenchless construction.
- B. Contractor shall assume sole responsibility for designing and sizing the shaft excavations to accommodate the construction method, all permanent structures, and conform to right-of-way limitations.
- C. Relocate, support, or bypass all utilities required in the performance of the Work.

1.2 REFERENCE SPECIFICATIONS, CODES, AND STANDARDS

- A. Comply with the following reference Specifications
 - 1. General Conditions
 - 2. Section 01130, Dewatering
 - 3. Section 02316, Pipe Ramming
 - 4. Section 02440, Pipe Jacking
 - 5. Section 02445, Instrumentation and Monitoring
 - 6. Section 02623, Microtunneling
 - 7. Section 03610, Ground Pre-Treatment
- A. Comply with the following industry standards effective at time of bid:
 - 1. ASTM A6 – Rolled Steel Plates, Shapes, Sheet Piling, and Bars for Structural Use
 - 2. ASTM A36 - Specification for Carbon Structural Steel
 - 3. ASTM A307 – Carbon Steel Bolts and Studs, 60,000 psi Tensile Strength
 - 4. ASTM A328 - Specification for Steel Sheet Piling
 - 5. ASTM A572 - Specification for High-Strength Low-Alloy Columbium-Vanadium Structural Steel
 - 6. ASTM A588 – High Strength Low Alloy Structural Steel with 50 ksi (345

MPa) Minimum Yield Point to 4 in. (100 mm) Thick

7. ASTM A688 – Steel Forgings, Carbon and Alloy, for General Industry Use
8. ASTM A690 – High-Strength Low-Alloy Steel H-Piles and Sheet Piling for USE in Marine Environments
9. ASTM A992 - Specification for Structural Steel Shapes
10. AWS D1.1/D1.1M - Structural Welding Code - Steel

1.3 SUBMITTALS

- A. Submittals shall be made in accordance with General Conditions, Section 02623, Section 02316, Section 02440, and as specified herein.
- B. Shaft submittals shall be coordinated with all relevant submittals, assembled and submitted as a single, comprehensive submittal.
- C. Working Drawings - Show pile layout details, pile load arrangement, driving sequence, and pile interlock and splice details. Include manufacturer's details and recommendations.
- D. Types, dimensions, and properties of piling to be furnished. Do not order delivery before receipt of written approval.
- E. Description of driving equipment for each pile type including hammer type with model number and manufacturer, rated driving energy, stroke, weight of ram, driving cap weights, and description of cushion.
- F. Driving record of each pile, including pile type, location, number, batter, pile length before cutoff, location of splice, existing ground elevation, final tip elevation, starting and finishing driving times, number of blows per each foot of penetration including number of blows per inch for the last six inches, actual rate of hammer operation in blows per minute, and deviation from plumb and from indicated location, and cause and extent of interruption of pile driving.
- G. Where calculations are required to be submitted, they shall be signed and sealed by a Professional Civil Engineer registered in the State of Colorado. Calculations shall clearly identify all parameters used, state all assumptions made in the calculation, and identify all sources of information.
- H. Detail Drawings
 1. Drawings of all fabricated accessories.
 2. Installation layout drawings for acceptance.
 3. All shop drawings shall be legible with dimensions accurately shown and

clearly marked in English.

4. Qualifications of Contractor's Design Engineer.

5. Product Data:

a. Materials specified in Part 2.

b. Material Safety Data Sheets.

c. Manufacturer's mixing and handling requirements, personal safety equipment, first aid measures, and methods for proper storage and disposal of waste materials, including containers.

I. Certificates

1. Notarized copies of chemical and physical test results, and test reports indicating material has met specified minimum interlock strength of interlocked joint.

2. Notarized statement from coater that surface preparation and protective coating has been applied so that coating will survive driving of piles.

J. Testing

1. Test Procedures to be performed to prove validity of design and compliance of installation.

K. Work Plans.

1. Contingency Plans.

2. Field Inspection Plans.

L. Pre-Construction submittals:

1. Calculations.

2. Shop drawings.

a. Existing Site Plan: for each shaft location indicating utilities, structures, protective barricades and vegetation that are to be protected in place.

b. Site Plan: for each shaft indicating the location, excavation dimensions, site grading, and site development details for the excavation and work areas, and the proposed limits of disturbance. Include details of types, amounts, and positioning of materials and equipment required at each location. Show overhead utilities and other overhead conflicts.

c. Methods, procedures, and sequence for preloading and installing

- bracing.
 - d. Foundation details for all permanent structures.
 - e. Sequence for removing shoring in conjunction with backfill placement.
- M. Daily Construction Logs: include the following as applicable:
- 1. Shoring element number, location, length, plumbness, and bearing material.
 - 2. Concrete, grout, and steel properties.
 - 3. Dates for excavation completed and concrete placed.
 - 4. Diameter of top and bottom of shaft.
 - 5. Elevations of top of ground, top of shoring elements, and bottom of shoring elements.
 - 6. Results of all tests and observations.
 - 7. Shaft field inspection data on the same date as taken and interpretation by noon the following work day.
- N. Contractor's CDOT Submittal:
- 1. Refer to CDOT's Utility/Special Use Permit.

1.4 DESIGN REQUIREMENTS

- A. Design shafts to conform to right-of-way limitations as shown on the Contract Documents.
- B. Design temporary shoring system to provide a minimum factor of safety of 2.0 and 1.5 against bottom heave. Design shaft sides and bottom sufficient to support Contractor's construction equipment and means and methods.
- C. Coordinate the shaft design and construction with the requirements of Sections 02316, 02440, 02621, 02623, 02715 and 03610, the selected means and methods for performing the Work, and the permanent structures shown on the Contract Documents. These include, and are not limited to, designing and constructing jacking shafts for the maximum allowable jacking forces and loads induced by ground pre-treatment.
- D. Design excavation support systems compatible with the subsurface ground conditions identified in the Geotechnical Report prepared by Huddleston Berry included as part of these specifications by reference in Appendix B.
- E. Construct the shaft in-the-wet without dewatering. Removing water from the enclosed shaft volume shall not be performed until the shaft attains design strength.

- F. Upon completion of shaft excavation and removal of the water contained within the shaft, install sump pump(s) to remove all incidental, construction, and storm water.
- G. Steel sheet pile retaining wall designed and sealed by a civil or structural engineer registered in State of Colorado.
- H. Steel Sheet Pile Retaining Wall - Independently checked by a civil or structural engineer licensed in the State of Colorado.
- I. Capable of supporting both construction and long term loads at stress levels indicated in the contract drawings and the contactors site layout.
- J. Design, Calculations and Drawings - Signed and sealed by a civil or structural engineer registered in State of Colorado.
- K. Do not begin construction of Shaft without acceptance of design by Engineer or its designee.

1.5 PRODUCT DELIVERY, STORAGE AND HANDLING

- A. General requirements for delivery - ASTM A6.
- B. Store and handle materials to prevent damage and as recommended by manufacturer.

PART 2 – PRODUCTS AND EQUIPMENT

2.1 MATERIALS

- A. Steel Sheet Piling - ASTM A328, ASTM A572, or ASTM A690 as determined by Contractor's design analysis. Material for steel piles - Do not use material made by acid Bessemer process.
- B. Provide matching corners, tees, wyes and crosses as appropriate for selected accepted steel sheet piling.
- C. Wales, Plate Washers and Tie Rods - ASTM A36, ASTM A572, or ASTM A588 as determined by steel strength selected for sheet piling.
- D. Bolts and Nuts - ASTM A307 or ASTM A588, galvanized, as required, for strength indicated in calculations.
- E. Turnbuckles - ASTM A668, Class as determined by design.
- F. Coal-Tar Epoxy - Paint piles with two coats (16 mil dry film thickness) of Carboline Carbomastic 16 HFP, Valspare 64J3, or approved equivalent coal-tar epoxy. Surface

preparation and applications, and touch-up to damaged areas before driving - In accordance with coating manufacturer's instructions.

2.2 PILES

- A. Steel Sheet Piling - Standard interlocking sheet pile Sections with positive continuous interlocks in both longitudinal and transverse directions, continuous throughout entire length of piece when in place. Piling - new material produced by a single source.
- B. Size, Type Configuration and Weight - As determined by Contractor's design. Indicate properties of shapes selected including:
 - 1. Type/shape
 - 2. Web thickness in inches.
 - 3. Section modulus per linear foot of wall (inch³).
 - 4. Weight per linear foot of pile (in pounds).
 - 5. Weight per square foot of wall.
- C. Piling - Standard size handling holes located approximately four inches below top of pile.
- D. Welded Connections - Conform to AWS D1.1.
- E. Provide additional length beyond indicated length for trimming tops of sheet piling.
- F. Steel Sheet Piles and Interlocks - No excessive kinks, camber or twist that could prevent pile from reasonably free sliding during installation.

2.3 DRIVING EQUIPMENT

- A. Vibratory Pile Driving Equipment – Vibratory Driving Equipment shall be provided with sufficient energy to drive piles at penetration rate not less than required to provide indicated penetration and thrust capacity.
- B. Drop Hammers will not be permitted.
- C. Driving Equipment That Damages the Piling - Do not use. Use driving heads or driving blocks which hold the pipe in position directly under hammer during driving.
- D. Piles - Drive to position and line indicated or as directed, based on required penetrations as determined by Contractor's accepted design. Piles materially out of

line will be rejected. Remove rejected piles which interfere with work at no additional cost to the City.

- E. Log driving information. Submit copies of log to Quality Control Manager for inclusion in their report.

PART 3 – EXECUTION

3.1 GENERAL

- A. Perform all work in accordance with accepted submittals.
- B. Provide the Engineer and the City with access to the shaft.
- C. Maintain a copy of the Contract Documents at a location acceptable to the Engineer and accessible to the shaft construction contractor and the Engineer.
- D. The Contractor, prior to beginning any shaft excavation five (5) feet deep or more, shall submit to the Engineer and shall be in receipt of written acceptance by the Engineer of the Contractor's detailed work plan, calculations, shop drawings and product data for all shoring, bracing, sloping of sides of, excavation, or other provisions for worker protection against the hazard of caving ground during shaft excavation, tunneling and other work. The Contractor's attention is directed to the provisions for Shoring and Bracing Drawings in the Colorado Labor Code.
- E. Dewater in accordance with the requirements specified in Section 01130, Dewatering.

3.2 SHAFT CONSTRUCTION: GENERAL

- A. Protect existing structures, utilities, vegetation, and facilities before commencing shaft excavation.
- B. Construct instrumentation as shown on the Contract Documents and as specified in Section 02445 before shaft excavation.
- C. If settlement or deflections of supports or shaft bottom indicate the support system requires modification, the Contractor's engineer shall redesign and resubmit revised shop drawings and design calculations at the discretion of the Engineer.
- D. If the contractor creates increases the surcharge loading near or around the shaft the Contractor's Engineer shall redesign and resubmit revised shop drawings and design calculations to accommodate the
- E. Provide ground pre-treatment in accordance with the requirements established in Section 03610 and the Contract Documents.
- F. Construct jacking shafts with the shoring flush with the existing ground surface or extending not more than 4 feet above the existing ground surface.

- G. The lagging, spiling or casing shall extend at least one foot above ground level and shall be provided the full depth of the shaft or at least five feet into stiff soil if possible.
- H. All wells, pits, shafts, caissons, etc., shall be barricaded using approved Type 7 barrier at a 20:1 taper around the area or otherwise directed by the Engineer.
- I. All wells, pits, shafts, caissons, etc., shall be and securely covered when the Contractor is not onsite.

3.3 INSTALLATION

- A. Before placing any steel sheet piles, mark layout. Contact subsurface utilities and request they mark their adjacent facilities. Where utilities are within two feet of steel sheet piles, expose existing utility by hand excavation. Protect existing utilities during the pile installation.
- B. If possible, place piles without interruption from first blow until average final set in or with a vibratory hammer which will force pile to penetrate by its own weight and weight of engines bearing on top. Vibrate the piles into place; do not drive.
- C. Cut piles in plane as indicated. Fill space around piles with dry sand or crushed stone. Cutoff portions of piles - remain property of Contractor. Transport portions from Worksite except if of a type and length which could be used for other piles on Worksite, cut off portions may be incorporated as a part of other piles.
- D. Provide electrical continuity between metal elements of structure, including top channel by welding two reinforcing bars across each joint. Weld in accordance with AWS D1.1.
- E. Weld on channel cap in accordance with AWS D1.1, and fill space around pile with dry loose sand within one hour after pile has been driven.
- F. Splice steel piles with full penetration butt welds over entire cross Section. Align adjacent sections so axes of piles are straight. Limit number of splices in length of pile to two. Splices in top ten feet of pile - not permitted. Locations of pile lugs, when used. Welding by qualified welding operators only.
- G. Noise and Vibration Limits - In accordance with Section 02445, Instrumentation and Monitoring and the General Conditions.

3.4 DETERMINATION OF SHAFT SIZE AND LOCATION

- A. Shaft locations are approximated on the Contract Drawings. The Contractor is responsible for determining the dimensions required for construction.

- B. Piles - Of length required to develop specified capacity, obtain specified penetration, and to extend to depth and provide capacity indicated on Contractor's reviewed and accepted Drawings.
- C. Furnish piling of sufficient length to obtain penetration and capacity required.

3.5 EXCAVATION

- A. Locate all utilities in accordance with General Conditions before commencing excavation.
- B. All earthwork shall be in accordance with Section 2300, Earthwork and Trenching.
- C. Fill and compact with backfill in accordance with Section 2300, Earthwork and Trenching.
- D. Dispose of contaminated ground in accordance with General Conditions.

3.6 SHAFT CONSTRUCTION: INTERNAL BRACING SUPPORT SYSTEM

- A. Construct the internal bracing support system using walers, struts, and/or shores as required by the design accepted in the Contractor's submittals.
- B. Construct and maintain all bracing support members in intimate contact with other support members and with the ground.
- C. Preload bracing members by jacking struts to 50 percent of the design load if necessary to control shoring movement.
- D. Preload bracing members in accordance with methods, procedures, and sequence as described on the shop drawings.
- E. Use procedures that produce uniform loading of bracing members without eccentricities or over-stressing and distortion of members or system.

3.7 STEEL SHEET PILING SHAFT CONSTRUCTION METHODS

- A. The following are selected methods that meet the design and performance requirements specified herein. Choose one of the following methods or another method that meets the requirements specified herein.
- B. Interlocking Steel Sheet Piles
 1. Design and construct the shaft bottom as an integral part of the entire shaft.
 2. Remove all steel subsurface ground support materials, except for those lying directly below the installed jacked pipe.
 3. Piles shall be guided and held in position by temporary gates with each

pile properly interlocked with its neighbor.

4. Where shaft extends into obstructions, extend sheet piles to depth required by predrilling into subsurface material.

C. Jet Grouting for Ground Pre-Treatment

1. See Section 03610, Ground Pre-Treatment for Jet Grouting procedures.

3.8 REMOVAL OF SUPPORT SYSTEM/SITE RESTORATION

- A. After all equipment and excavated materials for the tunneling operations have been removed from the jacking shaft, the Contractor shall prepare the bottom of the shaft in the same manner as a pipe foundation, the Contractor shall remove all loose and disturbed materials below pipe grade to undisturbed ground and re-compact the material in accordance with CDOT Sections 200. The installation of the sanitary sewer manholes near the ends of the tunneled portion shall be in accordance with the plans and specifications.
- B. The contractor shall remove all support of excavation materials from the shaft /pit area once tunneling and installation is complete. The contractor shall remove all materials with the exception of the approved backfill materials. The removal of the ground support system shall be performed in a manner that avoids ground settlement and damage to adjacent facilities. The Engineer may instruct additional remediation due to the settlement at no additional cost to the City if settlement occurs during or after installation/removal of the ground support system. The shafts shall be backfilled in accordance with the CDOT Sections 200. The Engineer may elect to leave the shoring and sheet piles in place if the contractor cannot remove the support without creating settlement within acceptable limits.
- C. Site restoration shall be completed at all shaft locations restoring site to its original pre construction condition in its entirety.

3.9 GROUNDWATER INFLOW REQUIREMENTS

- A. Construct the shaft using water-tight construction methods that limit water inflow to less than 10 gallons per minute from all sources before and during tunneling operations except as specifically specified otherwise. The construction of the shaft and sheet pile shall be constructed in the wet conditions. Refer to Section 02621. Limit groundwater inflow before trenchless construction commences.
- B. Do not use dewatering method during shaft construction. Sump pumping is allowed as an exception to collect surface-water run-off from construction activities or precipitation. The contractor shall not construct dewatering wells or pumping to draw down the groundwater level during the construction of the shaft or trenchless construction. The total sump pumping discharge for sump pumping shall not exceed 10 gallons per minute.

3.10 QUALITY CONTROL, TESTS, AND INSPECTIONS

- A. Provide quality control, testing, and inspection as required in the accepted submittals.
- B. Qualification of Construction Supervisor will be reviewed by Engineer or its designee for acceptance. Supervisor's experience - Work similar to that specified having been in responsible charge of that Work.
- C. Field Quality Control - Inspect piles for deformation, misalignment, tears, splits, and other damage immediately before and periodically during driving operations. Furnish adequate lighting for inspection of piles.
- D. Comply with requirements of Federal, State, and local authorities having jurisdiction.

3.11 QUALITY ASSURANCE

- A. Engineer: Excavation support systems shall be designed by a Civil or Structural engineer registered in the State of Colorado who has a minimum of five (5) years' experience in shaft designs including shafts of similar size and in similar ground conditions as measured by ground type, N values, and depth of groundwater.
- B. Surveyor: Surveying shall be performed by a Colorado licensed surveyor who has surveyed a minimum of five (5) shafts in the last five (5) years.
- C. Initial Survey: Prior to beginning demolition or excavation, perform a survey in accordance with the General Conditions that identifies and locates facilities within 50 feet of the shaft excavation.
- D. Work Plan: Loads, materials and equipment to be used, the method and sequence and timing of installation, and site restoration plan.
- E. Contingency Plan: Describe the steps and actions needed to stabilize the excavation and excavation support systems if the excavation becomes unstable or the monitoring data indicate movements exceed the allowable limits. Include a list of contingency materials and equipment to be kept available on site for installation.
- F. Field Inspection Plan: Field verification of ~~the~~ shaft design that at a minimum, measures and records settlement, bottom heave, groundwater elevation, and shaft member deflections daily in accordance with Section 02445.

3.12 REMOVAL OF SUPPORT SYSTEM / SITE RESTORATION

- A. After all equipment and excavated materials for the trenchless construction operations have been removed from the jacking shaft, the Contractor shall prepare the bottom of the shaft in the same manner as a pipe foundation, the Contractor shall remove all loose and disturbed materials below pipe grade to undisturbed ground and re-compact the material in accordance with CDOT Sections 200. The installation of the sewer manholes near the ends of the trenchless portion shall be in accordance with the plans and specifications.
- B. The contractor shall remove all support of excavation materials from the shaft /pit

area once trenchless construction and installation is complete. The contractor shall remove all materials with the exception of the approved backfill materials. The removal of the ground support system shall be performed in a manner that avoids ground settlement and damage to adjacent facilities. The Engineer may instruct additional remediation due to the settlement at no additional cost to the City if settlement occurs during or after installation/removal of the ground support system. The shafts shall be backfilled in accordance with the CDOT Sections 200.

- C. Site restoration shall be completed at all shaft locations restoring site to its original pre construction condition in its entirety.

3.13 PROJECT/SITE CONDITIONS

- A. See Section 02316, Pipe Ramming, 02440 Pipe Jacking, or 02623, Microtunneling for subsurface ground information.

****END OF SECTION****

PART 1 - GENERAL

1.1 SECTION INCLUDES

- A. Removal of existing sampling station and concrete slab as shown on the Drawings.
- B. Isolate, de-energize and disconnect all utilities as specified herein and shown on the Drawings.
- C. Demolish, remove and dispose of a portion of the existing effluent structure wall as shown on the Drawings.

1.2 SITE CONDITIONS

- A. CONTRACTOR shall be responsible for verifying that each and every utility in the vicinity of the work to be demolished, above and below grade, has been de-activated and is safe for demolition and removal.
- B. All existing work to remain, connected and/or adjacent to the work to be removed shall be shored, braced, covered, or otherwise protected from damage due to demolition operations or the temporary removal of portions of any structure.

1.3 1.3 DISPOSAL OF MATERIALS AND DEBRIS

- A. All demolition materials, debris, waste, or other materials shall be collected, stored, handled, managed, and disposed in accordance with currently accepted practices at an approved, licensed, or permitted facility in accordance with applicable federal, state, and local ordinances, rules, and regulations.

1.4 PERMITS

- A. CONTRACTOR shall obtain, at his expense, any and all permits required by local, state, and federal agencies. Copies of permits shall be maintained at the site and readily produced upon request.
- B. All inspections required by the permits will be required and provisions for safe access to perform inspections shall be made by the CONTRACTOR.

PART 2 - PRODUCTS (NOT USED)

PART 3 - EXECUTION

3.1 TEMPORARY SUPPORT

- A. Provide and install all temporary shoring, bracing and other supports as is necessary to prevent movement, cracking, collapse, etc. of for existing work to remain. Drilled holes, inserts, embedments and other temporary attachments that will remain visible following completion of the work shall not be permitted.

3.2 CONTAINMENT AND SECURITY

- A. Construct temporary working platform(s) below, and temporary containment barriers around, all demolition work prior to commencing Work.
- B. Contain all debris, dust, fumes, etc. controlling them within the immediate vicinity of removal, through-out the duration of the demolition operations. Do not allow any materials to free-fall, rotate, swing, or otherwise release uncontrollably unless adequate precautions and protections are in place.
- C. Provide and install physical barriers to prevent access to areas that may be hazardous to workers or the public.

3.3 DEMOLITION

- A. Unless specifically excepted by the ENGINEER, boundaries of all areas to be demolished shall be sawcut along straight lines parallel to, or perpendicular to, existing walls, edges of slabs, or other work to remain.
- B. Demolition operations shall not induce excessive, i.e. damaging, vibrations to remaining, adjacent or nearby structures.

3.4 DEBRIS AND WASTE REMOVAL AND DISPOSAL AND CLEANUP

- A. Remove all debris, trash and demolition-related waste from site.
- B. Dispose of waste materials in a proper manner, in conformance with local, state and federal regulations. Submit copies of all receipts, manifests and other documentation from receiving waste site(s).
- C. Clean up spillage and wind-blown debris from public and private areas.

END OF SECTION

Section 02440 Pipe Jacking

PART 1 GENERAL

1.1 Summary

- 1.1.1 This section covers Pipe Jacking for installation of the 60 inch Steel Pipe. Excavation may also be conducted by other tunnelling methods specified in the Contract Documents and is to be determined by the Contractor.
- 1.1.2 The Contractor shall furnish all materials and equipment necessary for installation of the Steel Pipe as shown on the Contract Drawings and is responsible for selecting their means and methods for completing the installation of the Steel Pipe in compliance with the specifications.
- 1.1.3 Open-shield pipe jacking shall include fabrication, transportation, testing, installation, and launch of the open-shield pipe jacking equipment; installation and use of all other pipe-jacking and excavation equipment; the excavation, handling, removal, and disposal of all materials encountered in the tunnel excavation; installation of Steel Pipe where shown in the drawings or specified in the contract documents; collecting, treating, and conveying all tunnel construction water according to local and regional protocols; provision of all temporary drainage, tunnel ventilation, lighting, wiring, and all other utilities; tunnel safety; environmental protections and all appurtenant work necessary to complete the work in accordance with the Contract Documents.
- 1.1.4 The excavated diameter of the tunnel shall be determined by the Contractor based on its selected construction means, methods and equipment, subject to the limitations as shown on the Contract Drawings or stated elsewhere in the Specifications. Excavate the tunnel to the selected size; to the line and grade to allow the Steel Pipe pipes to be placed using pipe jacking methods to the line indicated on the Drawings; and to within the tolerances specified herein.

1.2 Related Sections

- 1.2.1 Section 01130 – Dewatering
- 1.2.2 Section 02315 – Steel Casing Pipe
- 1.2.3 Section 02356 – Steel Sheet Piling
- 1.2.4 Section 02445 – Instrumentation and Monitoring
- 1.2.5 Section 02621 – Shaft Construction
- 1.2.6 Section 03360 – Contact Grouting

1.3 Reference Specifications, Codes, and Standards

- 1.3.1 ASTM D422 - Standard Test Method for Particle-Size Analysis of Soils
- 1.3.2 ASTM D4318 - Standard Test Methods for Liquid Limit, Plastic Limit, and Plasticity Index of Soils
- 1.3.3 OSHA - Occupational Health and Safety Act (OSHA) Regulations for Construction Projects; Tunnels, Shafts, Caissons, and Cofferdams, S. 243-331.

1.4 Definitions

- 1.4.1 **Open-Shield Pipe Jacking:** For the purposes of this specification, open-shield pipe jacking is defined as a technique for installing pipe by jacking it into place from a jacking shaft to a receiving shaft, using hydraulic jacks. Soil excavation is performed within a shield in front of the lead pipe segment using hand-mining, mechanical methods such as a digger-boom, or with mechanized equipment such as a tunnel boring machine (TBM). The open shield allows access to the excavation face from inside the bore. The shield is steerable using hydraulic jacks to orient an articulated section of the shield, and guidance can be provided using a laser or theodolite system. Pipe jacking with an Earth Pressure Balance capable TBM operating in open-mode is considered a form of open-shield pipe jacking.
- 1.4.2 **Jacking Pipe:** The pipe jacked behind the shield. The jacking pipe shall be specifically designed to be installed by pipe jacking to meet the final design requirements.
- 1.4.3 **Intermediate Jacking Station (IJS):** A fabricated steel cylinder fitted with hydraulic jacks spaced around the circumference, which is incorporated into the pipeline between two specially fabricated pipe sections. The function of an intermediate jacking station is to distribute the jacking load along the pipe string during pipe installation. The hydraulic jacks are removed at the completion of a drive and the gap between adjacent pipe sections is fully closed by pushing the pipes together with the main shaft jacks or another IJS. The steel cylinder remains as an extended sleeve or coupling. The steel cylinder must be protected from corrosion, consistent with corrosion protection used for the jacking pipe and joints.
- 1.4.4 **Launch/Retrieval Seal or Entry/Exit Seal:** A mechanical seal usually comprised of one or more rubber flanges attached to a steel housing that is mounted to the wall of the jacking/receiving shaft. The shield or jacking pipe distends the flange seal as it passes through, creating a seal to reduce water, lubrication, and soil inflows into the shaft during pipe jacking operations.
- 1.4.5 **Lubrication/Grout Port:** A port located within the shield or in a jacking pipe segment, fitted with a one-way valve, for injection of lubrication material or grout into the annular space between the pipe and the ground. Lubrication ports within the pipe are typically threaded to accept lubrication/grout fittings. Pipe plugs are inserted after grouting is completed. A lubrication station consists of an array of lubrication ports at shield or pipe positions.
- 1.4.6 **Obstruction:** See 3.4 for definition of obstructions.

1.5 Submittals

1.5.1 Procedures: Refer to Section 01330, Contractor Submittal Procedures

1.5.2 Qualifications:

1.5.2.1 Submit documentation that the requirements of 1.6 Quality Control have been met.

1.5.3 Informational Submittals:

1.5.3.1 Pipe Jacking Equipment: Submit the following describing the pipe jacking equipment and construction methods:

1.5.3.1.1 A detailed description of the methods and equipment to be used in completing each pipe jacking drive.

1.5.3.1.2 The excavation diameter based upon the outermost dimensions of the gauge cutters or shield. Also, provide the radial overcut which shall be determined as the difference between the maximum excavation diameter and the outer diameter of the jacking pipe, divided by two.

1.5.3.1.3 Manufacturer's literature describing the pipe jacking system including the TBM or shield and all ancillary equipment. Provide descriptions of at least two projects on which this system has been successfully used including names, current addresses, and telephone numbers of The City's representatives for these projects as well as lengths, diameters, soil conditions, and pipe materials used. If a used or refurbished TBM or shield is proposed, list previous usage, modifications made and dates of modifications, and detailed description of the extent and dates of refurbishment. Include the following information concerning the TBM or shield:

- (a) Dimensions.
- (b) Torque, Thrust, rotation speed range, and all specifications for mechanical equipment used.
- (c) Cutter types, configuration, and gauge cutter setting for overcut.
- (d) Articulation and steering capability.
- (e) Cutterhead jets/ports information, locations, and sizes.
- (f) Face accessibility and plate or flood door provisions.
- (g) Tail seal details.

- (h) List of spare parts and their lead time in case of damage.
 - (i) Material Safety Data Sheets (MSDS) for all consumables used including but not limited to tail seal grease.
- 1.5.3.1.4 A description of the alignment control (guidance) system. Provide manufacturer's literature and Drawings, showing setup and support provisions, and other details for the laser or theodolite system. Submit a description of surveying methods to set guidance system positions and a description of procedures to check and reset or realign guidance system during construction. Submit a description of methods to ensure that thrust block, launch seal, and jacking frame are installed on proper line and grade. Confirm that these systems can achieve the required line and grade within the specified tolerances. Submit the template for reporting daily tunnel advance, Horizontal & Vertical deviations from tunnel designed alignment after each "push".
- 1.5.3.1.5 Ventilation and air quality monitoring system, including monitors for shield or TBM deactivation and alarm activation. Include provisions to check and control dust in vicinity of all personnel working underground.
- 1.5.3.1.6 Submit results of line and grade survey to ensure that the thrust block, jacking frame, and launch and retrieval seals are installed properly, prior to launch.
- 1.5.3.1.7 Capacity, number, and arrangement of main jacks. Provide details of thrust ring, thrust block, jacking frame, jacking controls, pressure gages, and jack calibration data (pressure vs. force relationship for each stage of the jacks).
- 1.5.3.1.8 Details of pipe lubrication injection system and pipe lubricants to be used during pipe jacking, including manufacturer's literature and MSDS sheets. Include a description of proposed lubrication procedures during jacking, including estimated volumes of lubricant that will be pumped. Confirm that sufficient volume of lubricant will be pumped at all times to completely fill the annular space outside the jacking pipe.
- 1.5.3.1.9 Details of spoil removal and handling systems, transport, and disposal equipment and procedures including spoil disposal sites. Provide written documentation from the disposal site(s) indicating that they will accept the spoil and are in compliance with applicable regulations.
- 1.5.3.1.10 Drawings and design details for intermediate jacking stations, indicating number required, shell materials, proposed spacing, criteria for installing, and method of operation.

- 1.5.3.2 For used and refurbished TBM or shield only, the Contractor shall submit the following:
- 1.5.3.2.1 Certification in writing that the TBM or shield has been refurbished and reconditioned to meet the requirements of this Section. This shall include but not be limited to motors, jacks, hydraulics, mechanical components, bearings other than the main bearing, seals, electrical, electronic and other major components of the TBM or shield and back-up equipment. The certification shall include a statement on expected remaining main bearings and bearing seal life hours and adequacy to complete the work without bearing and seal replacement.
 - 1.5.3.2.2 Qualifications of machine rebuilder demonstrating that the TBM or shield rebuilder has rebuilt TBMs or shields of similar type, size and complexity, used in successfully completed, similar size projects.
- 1.5.3.3 Shaft Layout Drawings: The Contractor shall submit shaft layout drawings detailing dimensions and locations of all equipment, including overall work area boundaries, crane, front-end loader, forklift, spoil stockpiles, spoil hauling equipment, jacking frame, pumps, generator, lubrication plant, pipe storage area, tool trailer or containers, sound baffles, fences, site offices, first aid cabins, parking areas, and staging area. Shaft layout drawings will be required for jacking and receiving shaft locations and shall be to scale, or show correct dimensions. The Contractor's layout drawings shall show that all equipment and operations shall be completely contained within the allowable work areas shown on the Drawings.
- 1.5.3.4 Schedule: Provide a schedule for all pipe jacking work, identifying all major construction activities as independent items. The schedule shall include, at a minimum, the following activities: obtain licenses, utility locates and permits, site preparation, mobilization, installation of instrumentation, shaft excavation and support, working slab construction, thrust block construction, jacking equipment setup, entry/exit seal installation for launch/retrieval of shield, pipe jacking, retrieval of the shield, shaft backfill, site restoration, cleanup, and demobilization. The schedule shall also include the work hours and workdays for each activity, and a written description of the construction activities. The schedule will be reviewed by the Contract Administrator and shall be updated and resubmitted by the Contractor every two (2) weeks or more frequently if requested by the Contract Administrator.
- 1.5.3.5 Calculations: Calculations shall be submitted in a neat, legible format. Assumptions used in calculations shall be consistent with information provided in the Geotechnical Report. All calculations shall be prepared by a professional engineer licensed in Colorado, who shall stamp and sign calculations.

- 1.5.3.5.1 Design calculations demonstrating that the proposed jacking pipe is capable of supporting the maximum stresses to be imposed during jacking. The calculations shall take into account ground and hydrostatic loads, jacking forces, external loads such as live loads due to traffic, and any other loads that may be reasonably anticipated during jacking. All loads shall be shown and described. Include assumed maximum drive length. Additionally, provide an estimate of the maximum jacking force expected to complete each drive, accounting for both face pressures and frictional resistance along the pipe string.
- 1.5.3.5.2 Calculations demonstrating that the ground support system and soils and installed reaction piles, if used, behind the thrust block, or other thrust reaction element, can transfer the maximum planned jacking forces exerted by the main jacks to the ground during pipe installation with an acceptable factor of safety of at least 1.5, without excessive stresses, deflection, or displacement.
- 1.5.3.6 Jacking Pipe: Detailed drawings of the jacking pipe indicating the location and spacing of lubrication/grout fittings, joint details, joint cushioning materials, gaskets, and intermediate jacking station pipe details. Indicate the ultimate and allowable jacking capacity, the required fabrication tolerances to prevent damage to the pipe during installation, and provide a certification from manufacturer indicating that the pipe meets these tolerances and is designed to meet all anticipated loading conditions with an adequate factor of safety for designed operation period of tunnel/project.
- 1.5.3.7 Ground Stabilisation: Submit plan for controlling the loss of ground into the shafts at all times, including the periods during launch and retrieval of the pipe jacking shield, i.e., when exiting the launch shaft and entering the reception shaft. Provide details and dimensioned drawings on the entry and exit shaft seals and the mounting procedures.
- 1.5.3.8 Safety Plan: A Safety Plan for the pipe jacking operations including air monitoring equipment and procedures and provisions for lighting, ventilation, and electrical system safeguards. Provide name of site safety representative responsible for implementing safety program.
- 1.5.3.9 Contingency Plans: The following list includes problem scenarios that may be encountered during the pipe jacking operations. The Contractor shall submit contingency plans for dealing with each problem scenario while satisfying the specifications. These plans shall include the observations, communications with client/designer and measurements required to clearly identify the cause of the problems and remedial work.
 - 1.5.3.9.1 TBM or shield unable to advance:

- (a) Possible obstructions (including boulders, old foundations, well casings, metallic debris, or reinforced concrete).
- (b) Insufficient jacking capacity.
- (c) TBM or shield malfunction.
- (d) Spoil Removal Problems: Spoils becoming clogged on conveyor/auger system.
- (e) Noticeable hydrocarbon smell is detected in the TBM, shield, tunnel, or shaft.
- (f) Laser distorted by heat, humidity, or physical disturbance. Resetting and survey verification of the laser and associated fixtures is required prior to commencing jacking of the next pipe segment.

1.5.3.9.2 Jacking Forces:

- (a) Jacking forces increase dramatically or suddenly.
- (b) Jacking forces reach design capacity of pipe, jacking frame, or thrust wall (treat these scenarios as separate incidents).

1.5.3.9.3 Face instability when advancing the tunnel.

- (a) Running or flowing ground is encountered resulting in excess lost ground.
- (b) Groundwater inflows develop resulting in lost ground or in a manner that otherwise hinders progress.

1.5.3.9.4 Settlement and Subsidence:

- (a) Survey measurements indicate deformations exceed allowable limits as indicated in Section 02445, Instrumentation and Monitoring.
- (b) Excavated volumes significantly exceed pipe volume installed.
- (c) Voids are encountered or created by over excavation that may not be detectable by survey measurements.

1.5.3.9.5 Steering difficulties result in line and grade tolerances being exceeded.

- 1.5.3.9.6 Pipe has been damaged or has been found to be out of compliance with specifications:
 - (a) Before installation.
 - (b) During, or after installation.
- 1.5.3.9.7 Thrust block or frame or other thrust reaction element deforms excessively under jacking loads, or provides insufficient capacity to advance pipe.
- 1.5.3.9.8 Severe storms or flooding predicted; shaft flooding possible.
- 1.5.3.9.9 Pre-construction survey of existing conditions, including videotape and still photographs documenting conditions of existing gutters, sidewalks, driveways, and other structures or improvements.

1.5.4 Record Submittals:

- 1.5.4.1 Daily Records: The following daily records shall be submitted to the onsite Engineer for review, by noon on the next working day following the shift for which the data or records were taken:
 - 1.5.4.1.1 Jacking Records: The Contractor shall provide complete written jacking records to the Contract Administrator. These records shall include for each pipe, at a minimum: date, time, name of operator, tunnel drive identification, installed pipe number and corresponding tunnel length, time required and height of spoil per car to jack each pipe, time required to set subsequent pipe, spoil volumes (muck cars per pipe joint), soil conditions including occurrences of unstable soils and estimated groundwater inflow rates if any, jacking forces, steering jack positions, line and grade offsets, any movement of the guidance system, shield roll, intermediate jacking station use and jacking forces, volume and location of lubricant pumped, problems encountered with the pipe jacking shield or other components or equipment, and durations and reasons for delays. Manually recorded observations should be made at intervals of not less than four times per pipe, whenever conditions change, and as directed by the Contract Administrator. At least seven (7) days prior to the launch of the shield, the Contractor shall submit template of the jacking logs and daily/shift reports or records to be used.
 - 1.5.4.1.2 Survey Measurements: Survey measurements of pipe alignment and settlement points shall be submitted to the Contract Administrator within 24 hours of the measurements. Measurements shall be made in accordance with provisions and schedules in Section 02445, Instrumentation and Monitoring, or more frequently if directed by the Contract Administrator.

1.6 Quality Control

- 1.6.1 All open-shield pipes jacking work shall be performed by an experienced contractor who meets the qualification requirements of this specification. Failure to meet the qualification requirements is failure to fulfil the Contract and the Contractor will be required to obtain a subcontractor that meets the qualification requirements.
- 1.6.2 All open-shield pipe jacking work shall be performed by an experienced contractor who has at least six (6) years of experience in performing open-shield pipe jacking work and has completed at least three (3) similar projects involving at least 250 LF of open-shield pipe jacking on each project. At least one of the projects shall have an individual drive equal to or greater in length than the longest drive on this project. The contractor shall submit a description of referenced projects including owner's name and contact information, project superintendent, and machine operators. The contractor shall have experience with pipe jacking for pipes greater than 60 inch in diameter.
- 1.6.3 The project superintendent shall have at least five (5) years of experience supervising open-shield pipe jacking construction. The Contractor shall submit a description of referenced projects including owner's name and contact information, project superintendent, and machine operators.
- 1.6.4 The open-shield pipe jacking operator(s) shall have technical training in the operation of the proposed open-shield pipe jacking equipment and shall have completed, as a primary operator, at least three (3) similar open-shield pipe jacking projects involving at least 250 LF of open-shield pipe jacking on each project and shall have experience pipe jacking pipe greater than 60 inch in diameter. At least one of the projects shall have an individual drive equal to or greater in length than the longest drive on this project. The Contractor shall submit a description of referenced projects including owner's name and contact information, project superintendent, and machine operators.
- 1.6.5 The site safety representative and personnel responsible for air quality monitoring shall be experienced in tunnel construction and shall have current certification by OSHA or applicable safety regulator.
- 1.6.6 The surveyor responsible for line-and-grade control shall be a licensed Surveyor registered in the Colorado who has prior experience in similar projects.
- 1.6.7 The Contractor shall provide written notice to the Contract Administrator at least 72 hours in advance of the planned launch of the pipe jacking shield. All work by the Contractor shall be done in the presence of the Contract Administrator unless the Contract Administrator grants prior written approval to perform such work in Contract Administrator's absence. The Contractor shall immediately notify the Contract Administrator, in writing, when any problems are encountered with equipment or materials, or if the Contractor believes the conditions encountered are materially and significantly different from those represented within the Contract Documents.

- 1.6.8 The Contractor shall allow free access to Contract Administrator at all times and shall furnish necessary assistance and cooperation to aid the Contract Administrator in observations, measurements, data collection, and sample collection, including, but not limited to the following:
- 1.6.9 The Contract Administrator shall have full access to the pipe jacking shield and jacking system hydraulic pressure gauges, and all other instrumentation prior to, during, and following all pipe jacking operations. Additionally, the Contractor shall allow the Contract Administrator reasonable access to the pipe jacking shield for inspection of the excavation face.
- 1.6.10 The Contract Administrator shall have full access to spoils removed from the tunnel excavation prior to, during, and following all pipe jacking operations. The Contract Administrator shall be allowed to collect soil samples from tunnel face, the muck buckets or spoil piles a minimum of once per installed pipe section, or every ten (10) feet, whichever is more often, and at any time when changes in soil conditions or obstructions are apparent or suspected.
- 1.6.11 The Contract Administrator shall have full access to the bentonite lubrication plant prior to, during, and following all jacking operations. This shall include, but not be limited to, full access to visually inspect storage and mixing tanks, lubricant pressures and pumping rates, amount and type of lubricants on site and sampling and testing to determine lubricant properties.
- 1.6.12 The Contract Administrator to have access to all data logs generated by equipment, daily logs to be submitted for each shift, no later than the next working day.

1.7 Performance Requirements

- 1.7.1 Pipe Jacking Equipment:
 - 1.7.1.1 The open-faced pipe jacking shield shall be designed to support all ground loads which may be imposed upon it as well as any surcharge loads and loads imposed by the thrust jacks, steering mechanisms, and other appurtenances. The shield or TBM shall be continuous around its full perimeter and shall have suitable breast tables, sand shelves, breast jacks, closable flood doors, or other such provisions to support the excavation face and prevent loss of ground. Non-rotary type shields shall have a hood that covers the crown and projects not less than 24 inch nor more than 36 inch beyond the shield edge. The shield or TBM shall be capable of fully supporting the excavation face, including periods of shutdown or running/flowing ground conditions.
 - 1.7.1.2 The pipe jacking shield or TBM and excavation equipment selected for the project shall be compatible with the geologic conditions described in the Geotechnical Report, Geotechnical Report, and the geologic conditions anticipated by the Contractor. The pipe jacking shield or TBM, including the weight, dimensions, steering capabilities, and other characteristics, shall be suitable for, and capable of, efficiently advancing through the geologic conditions described in the Geotechnical Report and the geologic

conditions anticipated by the Contractor. The pipe jacking shield shall be capable of excavating or handling boulders or other hard objects as detailed in section 3.4, Obstructions.

- 1.7.1.3 The pipe jacking shield shall have an articulation joint between two segments of the shield, with a watertight joint. The shield shall be steerable in both the vertical and horizontal directions to allow the operator to maintain line and grade within the specified tolerances listed in this Section. The shield shall include laser or theodolite guidance checking capability on a continuous basis, and monitored continuously by the operator. The guidance system shall be designed to function at the maximum required drive length without loss of accuracy or reliability of function. If a rotary-type cutterhead is used, the cutterhead shall have a reversible drive system so that it can rotate in either direction or other suitable provisions to minimize rotation or roll of the shield and/or pipe during installation.
- 1.7.1.4 Prevent material from moving into the tunnel through the joint between the tail skin and the pipe.
- 1.7.1.5 Maximum allowable radial overcut values shall be selected to minimize potential settlements of the ground and subsurface facilities.
- 1.7.1.6 The jacking system shall be capable of continuously monitoring and logging the jacking pressure, the rate of advancement, and the distance jacked. The jacking system shall develop a uniform distribution of jacking forces on the end of the pipe.
- 1.7.1.7 A lubrication injection system shall be provided to inject pipe lubricant around the shield and jacking pipe to decrease frictional resistance. Lubrication ports shall also be used for contact grouting upon completion of the drive.
- 1.7.1.8 The spoil conveyance system shall be designed for the full range of ground conditions described in the Geotechnical Report and anticipated by the Contractor. The system shall allow determination of muck volumes per pipe jacked in terms of height per muck car or conveyor belt weights, if a conveyor belt system is used.
- 1.7.2 Methods and equipment used shall control surface settlement and heave above the pipeline to prevent damage to existing utilities, facilities, and improvements. Ground movements (settlement/heave) shall be limited to values that shall not cause damage to adjacent utilities and facilities. In no case shall settlements exceed the applicable values listed in Section 02445, Instrumentation and Monitoring.
- 1.7.3 The thrust block face or other thrust resisting element shall be constructed perpendicular to the proposed pipe alignment. The thrust block or other thrust resisting element shall be designed to withstand the maximum jacking forces developed by the main jacks, without excessive stresses, deflection, or displacement.

- 1.7.4 Pipe design for jacking loads and acceptable fabrication tolerances is the responsibility of the Contractor. Pipe shall be designed with a minimum factor of safety against the anticipated jacking load as defined in 02315 – Steel Casing Pipe.
- 1.7.5 The Contractor shall determine required spacing of intermediate jacking stations, based on geotechnical conditions described in the Geotechnical Report, estimated jacking forces, and jacking load capacity of the pipe and jacking frame proposed by the Contractor. An IJS shall be installed and used if anticipated or actual jacking forces exceed 70% of the allowable design capacity of the jacking pipe, jacking frame, thrust block, or thrust capacity of the main jacks, whichever is the lowest. The Contractor is responsible for all IJS that may be required, and pipe specials.

PART 2 NOT USED

PART 3 EXECUTION

3.1 General

- 3.1.1 Pipe jacking shall not begin until the following tasks have been completed:
 - 3.1.1.1 All required submittals have been provided, reviewed, and accepted.
 - 3.1.1.2 All notices, permits, licenses are obtained and/or given.
 - 3.1.1.3 Required traffic management plan to accommodate site and deliveries have been setup.
 - 3.1.1.4 Receiving shaft excavations and support systems have been completed for the planned drive in accordance with accepted submittals and the requirements of this Section and Section 02621, Shaft Construction.
 - 3.1.1.5 The Contractor has pre-grouted the soils at all entry and exit locations for the planned drive and behind thrust blocks or elements where necessary and as approved by the Contract Administrator to stabilise weak, running or flowing soils. The Contractor has confirmed that the ground has been improved to the extent that ground will remain stable without movement of soil or water while the entry/exit location shoring is removed and while the machine is being launched or received into a shaft or during jacking operations. The progressive steps identified below shall be used to confirm suitable ground improvements for all shaft types and entry/exit locations:
 - 3.1.1.5.1 After the Contractor believes that he has improved the ground sufficiently outside a given shaft seal, the Contractor shall demonstrate the suitability of the improvements by cutting a 2 inch diameter hole in the shoring wall near the centre of the bore. If no obvious soil and less than 3 gpm of water enters the shaft, the Contractor may progress to the next demonstration step. If any soil or greater than 3 gpm of water enters the shaft,

the Contractor shall seal the demonstration hole and further improve the ground before repeating the demonstration step.

- 3.1.1.5.2 After successful completion of the first demonstration step, the Contractor shall demonstrate the suitability of the ground improvements by cutting a 12 inch diameter hole in the shoring wall at the location of previous demonstration hole. If no soil and less than 3 gpm of water enters, the Contractor may progress to the next demonstration step. If any soil or greater than 3 gpm of water enters the shaft, the Contractor shall seal the demonstration hole and further improve the ground before repeating the demonstration step.
- 3.1.1.5.3 After successful completion of the first two demonstration steps, and if the Contractor believes the ground improvements are sufficient, the Contractor may proceed with remainder of the shaft wall penetration procedures.
- 3.1.1.6 The location, orientation and grade of the jacking frame or guide rails and entry/exit seals for the planned drive have been surveyed to ensure they are on the proper line and grade and to verify that they are properly supported. Special care shall be taken when setting the guide rails and jacking frame/elements to ensure stability and correctness of the alignment and grade. Guide rails or jacking frame/elements shall be securely attached to the shaft supports or concrete working slab, with supplementary braces, piles, concrete, or grout if necessary, to prevent movement or shifting during the work. Guidance system shall be calibrated and verified to start operation with required accuracy.
- 3.1.1.7 A start-up inspection of all mechanical and hydraulic systems associated with the pipe jacking operations has been completed. The system shall be tested to ensure that the pipe jacking shield and supporting equipment is functioning properly. The Contract Administrator shall be notified at least 72 hours prior to the start-up inspection and a site inspector representing The Contract Administrator shall be present during the start-up inspection. Key shield performance data shall be measured and recorded by the Contractor during this inspection, including cutterhead rotational torque (if a rotating cutterhead is used, including zero load torque), correct functioning of main and steering jacks, laser, and other components. The records of the start-up inspection shall be submitted to the Contract Administrator within 24 hours of the completed inspection.
- 3.1.1.8 Site safety representative has prepared a code of safe practices and an emergency plan in accordance with OSHA and other applicable requirements. Provide the Contract Administrator with a copy of each prior to starting pipe jacking. Hold safety meetings and provide safety instruction for new employees as required by OSHA. Conduct a pre-construction safety conference in accordance with OSHA requirements. Arrange this conference and inform the Contract Administrator of the time and place of the conference at least seven (7) days in advance.

- 3.1.1.9 All specified geotechnical and environmental instrumentation and monitoring required for the planned drive has been installed, approved, and baselined.
- 3.1.1.10 Pre-construction survey and documentation of existing conditions, i.e., driveways, sidewalks, curb and gutter, structures, etc. has been completed and transmitted to the Contract Administrator.
- 3.1.2 The Contractor shall furnish all necessary equipment, power, water, and utilities for pipe jacking, pipe lubricant mixing and pumping, spoil removal and disposal, grouting, and other associated work required for the Contractor's methods of construction.
- 3.1.3 Conduct all operations such that trucks and other vehicles do not interfere with traffic or create a mud, dust, or noise nuisance in the streets and to adjacent properties. Promptly clean up, remove, and dispose of mud or spoil spillage.
- 3.1.4 All work shall be done so as not to disturb roadways, adjacent structures, landscaped areas, or existing utilities. Any damage shall be immediately repaired to original or better condition and to the satisfaction of The Contract Administrator, at no additional cost to The City.
- 3.1.5 Whenever there is a condition that is likely to endanger the stability of the excavation or adjacent structures, the Contractor shall operate with a full crew 24 hours a day, including weekends and holidays, without interruption, until those conditions no longer jeopardize the stability of the work.

3.2 Pipe Jacking

- 3.2.1 Pipe jacking shall be completed in accordance with the accepted submittals, and all applicable permit conditions.
- 3.2.2 Provide a suitable jacking frame and thrust block or elements to carry out the work. Provide intermediate jacking stations (IJS) as required to complete the pipe jacking drives indicated on the Plans.
- 3.2.3 Transport the jacking pipe from storage to jacking shaft without damage. Transport methods shall be acceptable to pipe manufacturer. QA/QC inspection shall be performed by the Contractor and The City and observations to be recorded as soon as pipes are delivered on site and before lowering them down into the shaft. Damaged jacking pipe shall not be used in the work. When lowered, immediately set the pipe to be jacked on properly braced and supported guide rails or jacking frame. Unacceptable pipe as determined during this inspection or through any other inspection shall be removed from the site, properly disposed of, and replaced with acceptable pipe meeting specified requirements at no additional cost to The City. A repair procedure may be acceptable at the sole discretion of the Contract Administrator as indicated in Paragraph 3.2.5 below.
- 3.2.4 The axial forces from the thrust jacks shall be distributed to the jacking pipe uniformly through a properly designed thrust ring and cushion material to prevent damage to the ends of the pipe. The Contractor or pipe manufacturer shall install pipe

cushion materials between each jacking pipe joint. The cushion materials or compression rings shall be made of plywood or other materials recommended by the pipe manufacturer and reviewed by the Contract Administrator. The compression rings shall not protrude beyond the inner or outer diameter of the pipe. The compression rings shall be of sufficient thickness and stiffness to distribute the jacking load between successive pipe sections, and minimize eccentric loading.

- 3.2.5 Jacking pipe sections shall be jacked into position following the design line and grade without damaging the pipe. In the event a section of pipe is damaged during the jacking operation, the Contractor, with approval from the Contract Administrator, shall make temporary repairs to the pipe and shall jack the pipe through to the next shaft for removal. Other methods of repairing the damaged pipe may be proposed in a submittal for review by the Contract Administrator, who shall have sole discretion in determining acceptability of the submittal and acceptance of any repairs.
- 3.2.6 The pipe jacking shield shall be operated to restrict the excavation of the materials to a volume equal to the shield and pipe jacked, to prevent loss of ground and settlement or possible damage to overlying structures. The Contractor shall monitor, measure, and report excavated spoil volume. If excavated spoil volume with proper bulking factors exceeds the theoretical volume of the shield and pipe being installed (by 10%), the Contractor shall notify the Contract Administrator and promptly modify excavation and face support procedures to prevent further over excavation.
- 3.2.7 Pipe jacking operations shall control surface settlement and heave above the pipeline to prevent damage to existing utilities, facilities, and improvements. The Contractor shall repair any damage resulting from construction activities, at no additional cost to The City and without extension of schedule for completion. The Contractor shall pressure grout any voids caused by or encountered during the shaft construction or pipe jacking including the annular space created by the radial overcut of the shield (as specified in Section 03360, Contact Grouting). The Contractor shall modify equipment and procedures as required to avoid recurrence of excessive settlements or damage.
- 3.2.8 Provide a lubrication system, and inject pipe lubricants through injection ports at the rear of the pipe jacking shield and ports in the jacking pipe as necessary, to minimize pipe friction. Injection ports shall be installed by the manufacturer in the pipe at intervals not to exceed 10 LF along the pipe string. Pipe lubricants shall be injected continuously as the pipe is advanced. The volume injected shall not be less than that required to fill the annular void space outside the pipe. Inject greater volumes as required to minimize jacking forces.
- 3.2.9 Unless ground improvement/modification has been conducted in order to prevent settlement, excavate continuously 7 days per week and 24 hours per day when excavating tunnel within 10m in plan from any adjacent structures. The Contractor shall insure sufficient muck storage capacity is available on site prior to commencing tunnelling in proximity to a structure during muck hauling restrictions.
- 3.2.10 Completely contain, transport, and properly dispose of all excavated materials away from the construction site. Use only the disposal sites identified in approved submittals for spoil disposal.

- 3.2.11 Contact Grouting: Within 24 hours after pipe jacking is complete or sooner depending on ground conditions, fill the annular space created by the overcut of the shield with contact grout in accordance with Section 02455, Contact Grouting.
- 3.2.12 Probing and Exploratory Drilling
 - 3.2.12.1 Probe holes ahead of the excavation face with a minimum diameter of 3 inch shall use rotary drilling techniques and are intended to confirm the geological conditions to be encountered by the excavation and to detect groundwater, sand lenses, zones of wet silt and other potentially unstable soils. The probe holes shall be located as determined by the Contractor or as approved by The City, but at a minimum, probing shall be continuous in at least two holes spaced in face. Probe holes shall be logged by a qualified geologist or geotechnical engineer engaged by the Contractor.
 - 3.2.12.2 Where a probe hole indicates water inflow, apply further investigation by drilling an additional probe hole approximately 24 inch below the water bearing probe hole. Repeat this procedure until the water bearing strata has been dewatered sufficiently to maintain stability and safely proceed with the work.
 - 3.2.12.3 Overlap probe holes in longitudinal direction by at least 10 feet.
 - 3.2.12.4 The City shall be notified in advance of all probe and exploratory drilling.
 - 3.2.12.5 Interpret cores and discharge of probe holes with regard to soil behaviour during excavation ahead of the tunnel heading.

3.3 Control of Line and Grade

- 3.3.1 The City will establish the benchmarks on the ground surface as indicated on the Plans. The Contractor shall verify these benchmarks by survey prior to the start of construction, and shall confirm positions or report any errors or discrepancies in writing to the Contract Administrator.
- 3.3.2 After confirming that all established benchmarks provided for the Contractor's use are accurate, use these benchmarks to furnish and maintain all reference lines and grades for pipe jacking. The Contractor shall use these lines and grades to establish the exact location of the jacking pipe using a laser or theodolite guidance system. Submit to the Contract Administrator copies of field notes used to establish all lines and grades and allow the Contract Administrator to check guidance system setup prior to beginning each pipe jacking drive. Provide access for the Contract Administrator to perform survey checks of the guidance system and the line and grade of the jacking pipe on a daily basis during pipe jacking operations. The Contractor shall be fully responsible for the accuracy of the work and the correction of it, as required.
- 3.3.3 The jacking pipe shall be installed in accordance with the following tolerances:
 - 3.3.3.1 Variations from Design Line (Horizontal): 3 inch maximum.

3.3.3.2 Variations from Design Grade (Vertical): 6 inch maximum.

- 3.3.4 The shield or TBM shall be steered to maintain line and grade within the tolerances specified. This shall be achieved by continuously monitoring and adjusting line, grade, roll, and steering attitude during the operation. If the installation deviates from line or grade, make the necessary corrections, and return to the design alignment and grade at a rate of not more than 1 inch per 25 feet.
- 3.3.5 The guidance system shall be mounted independently from the thrust block and jacking frame to maintain alignment if there is movement of equipment during jacking. Stop pipe jacking operations and reset guidance system if its alignment shifts or is moved off design alignment and grade for any reason. Check guidance system setup and position of all intermediate lasers and mounting brackets at least once per shift. Guidance system should only be reset by experienced, competent surveying personnel in accordance with acceptable procedures.
- 3.3.6 Monitor line and grade continuously during pipe jacking operations. Record deviation with respect to design line and grade at least twice per pipe joint at approximately equally spaced intervals and submit records to Contract Administrator as requested.
- 3.3.7 If the pipe installation does not meet the specified tolerance, the Contractor shall correct the installation including any necessary redesign of the pipeline or structures and acquisition of necessary easements. All corrective work shall be performed by the Contractor at no additional cost to The City and without schedule extension, and is subject to the written approval of the Contract Administrator.

3.4 Obstructions

- 3.4.1 If the pipe jacking operations should encounter an object or condition that prevents the forward progress of the shield, the Contractor shall notify the Contract Administrator immediately. The Contractor shall correct the condition, and remove, clear, or otherwise make it possible for the pipe jacking shield and jacked pipe to advance past any objects or obstructions that impede forward progress of the shield. Upon written notification by the Contract Administrator, the Contractor shall immediately proceed with removal of the object by approved methods, as submitted by the Contractor in approved submittals.
- 3.4.2 The Contractor will receive compensation for removal of non-boulder obstructions, defined as metallic debris, reinforced concrete, whole trees, and other hard objects larger than 30% of the outer diameter of the shield, which cannot be broken up by the cutting tools or manually removed through open portions of the face of the shield with diligent effort, that are partially or wholly within the cross-sectional area of the bore. The Contractor must demonstrate that the non-boulder obstruction stopped or significantly impeded forward progress of the tunnel excavation for the object to qualify as an obstruction. Payment will be negotiated with the Contractor by The City on a case-by-case basis. However, any removal process that does not allow direct inspection of the nature and position of the obstruction will not be considered for payment.

- 3.4.3 The Contractor will receive no additional compensation for splitting, excavating, removing, clearing, or otherwise making it possible for the shield to advance past objects consisting of metallic debris, wood, unreinforced concrete, and other non-metallic objects or debris with maximum lateral dimensions less than 30% of the maximum outer diameter of the shield.
- 3.4.4 Boulder obstructions are defined as a boulder encountered at the heading of the tunnel, with a diameter greater than 30% of the excavated tunnel diameter, that stops or significantly inhibits forward progress of the tunnelling shield. For payment of boulder obstructions encountered during pipe jacking, refer to specification 01025, Measurement and Payment.

3.5 Safety

- 3.5.1 The Contractor is responsible for safety on the job site. Methods of construction shall be such as to ensure the safety of the work, Contractor's and other employees on site, and the public. Perform all work in accordance with all current applicable regulations and safety requirements of Federal, State, and local agencies. In the event of conflict, comply with the more stringent requirements.
- 3.5.2 When personnel are underground, furnish and operate a temporary ventilation system, and air and dust monitoring systems including continuous monitoring of hazardous, toxic, flammable, or explosive gases conforming to the requirements of OSHA. Operate and maintain a ventilation system that provides a sufficient supply of fresh air and maintains an atmosphere free of hazardous, toxic, or flammable gasses in all underground work areas.
- 3.5.3 All work shall conform to the requirements of OSHA. Gas testing shall be performed by a certified gas tester in accordance with OSHA requirements.
- 3.5.4 No gasoline-powered equipment shall be permitted in jacking and receiving shafts or tunnel at any time. Diesel, electrical, hydraulic, and air powered equipment is acceptable, subject to applicable local, State, and Federal regulations.

3.6 CLEANUP AND RESTORATION

- 3.6.1 After completion of pipe jacking, all construction debris, spoils, oil, grease, and other materials shall be removed from the jacking pipe, jacking and receiving shafts, and all Contractor work areas. Cleaning shall be incidental to the construction. No separate payment shall be made for cleanup.
- 3.6.2 Restoration shall follow construction as the work progresses, and shall be completed as soon as possible. Restore and repair any damage resulting from surface settlement caused by shaft excavation, or pipe jacking. Any property damaged or destroyed, shall be restored to a condition equal to or better than existing prior to construction. Restoration shall be completed no later than thirty (30) days after the pipe jacking is complete. This provision for restoration shall include all property affected by the construction operations. Restoration shall be incidental to the construction. No separate payment shall be made for restoration.

END OF SECTION

SECTION 02445

INSTRUMENTATION AND MONITORING

PART 1 - GENERAL

1.1 REQUIREMENTS

- A. This section specifies the requirements for installing geotechnical instrumentation, consisting of: inclinometers, settlement monitoring points, crack gauges, utility monitoring points, deformation monitoring points, and piezometers, to monitor ground and structural movements and groundwater fluctuations over the project duration. Additionally, the Contractor shall install other instrumentation as necessary to control operations, monitor ground conditions, and ground response to achieve specified project requirements and to prevent damage to existing structures and facilities.
- B. The work includes furnishing, maintaining, monitoring, and removing all instrumentation associated with the work specified herein and shown on the Contract Documents.
- C. All works under this section are considered part and incidental to shaft excavation and trenchless construction which is included and to be paid for under their specific bid items. No separate payment shall be made for Instrumentation and Monitoring.

1.2 REFERENCE SPECIFICATIONS, CODES AND STANDARDS

- A. Comply with the applicable reference Specifications:
 - 1. General Conditions
 - 2. Section 01130, Dewatering
 - 3. Section 02316, Pipe Ramming
 - 4. Section 02440, Pipe Jacking
 - 5. Section 02621, Shaft Construction
 - 6. Section 02623, Microtunneling
- B. Comply with the following industry standards effective at time of bid:
 - 1. ASTM C150 – Type II Portland cement
 - 2. ASTM C778 – Standard Specification for Standard Sand
 - 3. ASTM D5784 - Standard Guide for Use of Hollow-Stem Augers for

Geoenvironmental Exploration and the Installation of Subsurface Water-Quality Monitoring Devices

4. ASTM D6230 – Standard Test Method for Monitoring Ground Movement Using Probe-Type Inclinometers
5. NSF/ANSI Standard 060, Drinking Water Treatment Chemicals – Health Effects

1.3 DEFINITIONS

- A. For additional definitions refer to Section 02623.
- B. **Baseline Reading:** Value of instrumentation readings taken prior to construction to provide a consistent, repeatable (within a maximum deviation of 20% from their numerical average), established baseline against which all subsequent readings are compared.
- C. **Displacement Monitoring Point (DMP):** A control point consisting of an optical target, firmly attached or established on vertical and/or horizontal exterior surface(s) of a structure, used to monitor horizontal and vertical deformations and inclinations of structures.
- D. **Inclinometers:** Instrument used to monitor lateral movements of excavations and embankments.
- E. **Monuments:** A locking steel enclosure case installed to provide protection for instrumentation from vandalism, traffic, and/or debris.
- F. **Piezometer:** A control point where an instrument is installed below the groundwater table at sufficient depth to detect variations in the groundwater level at specified locations.
- G. **Response Value:** Predetermined trigger value of ground, structure or utility deformation at which when attained the Contractor provides written notice and meets with the Engineer within one work day (24 hours) to discuss operational changes that are being made so as to not attain the Shutdown Value. Operational changes shall include a discussion at what conditions the Contractor will replace the operator.
- H. **Settlement Monitoring Points (SMPs):** Vertical displacement monitoring points constructed into the ground to monitor the vertical changes in elevation over the project duration.
- I. **Shutdown Value:** Predetermined trigger value of ground deformation at which when attained Contractor stops Work until submittal and Engineer's acceptance of a written plan detailing corrective actions and restoration. Operations shall not resume until operational changes are implemented.

- J. Threshold Value: Predetermined trigger value at which when attained Contractor provides written notice of condition and meets with the Engineer.

1.4 PERFORMANCE REQUIREMENTS

1.5 QUALITY ASSURANCE

A. Qualifications:

1. Geotechnical Instrumentation Specialist: Individual shall be a professional engineer registered in the State of Colorado with experience in the installation and maintenance of geotechnical instrumentation similar to that specified herein on at least two prior projects similar in scope and size to this project. Instrumentation specialist shall prepare and stamp instrumentation shop drawings and supervise and direct instrument installation, instrument readings, and interpretations. This person is to be physically present at the project site to directly supervise the installation of these instruments. Substitutions for the Geotechnical Instrumentation Specialist during the Contract period shall not be made without prior acceptance by the Engineer. Substitute personnel shall have the same qualifications specified herein for the positions to be held.
2. Surveyor: Individual shall be a land surveyor licensed in the State of Colorado for at least five years.
3. Technicians: Individuals shall be qualified with a minimum of two (2) years of experience in the installation of geotechnical instrumentation similar to those specified herein.
4. Drillers: Personnel employed for drilling instrumentation boreholes shall have at least four (4) years of direct field experience in drilling boreholes.
5. The Contractor's instrumentation data collection personnel shall have acceptable direct field experience and/or acceptable on-the-job training and supervision in collecting data from the types of instrumentation specified herein.
6. Products used in the work of this Section shall be produced by manufacturers regularly engaged in the manufacturing, installing and servicing of similar items with a history of successful production acceptable to the Engineer as specified herein.

B. Product Data: Includes manufacturer's product description, installation requirements, shop drawings, operation, maintenance procedures, and samples where applicable, as well as description of methods and materials for installing and protecting the instruments, including post installation acceptance tests.

1. Pre-construction and post-construction photographs shall be high-resolution,

- demonstrate the vertical nature of the feature, and include a scale.
2. Take photographs from the public right-of-way or on properties where access permission has been granted.
 3. Post-construction photos shall be of the same orientation and lighting as the corresponding pre-construction photographs.
- C. Settlement Surveying and Monitoring Plan: The plan shall identify the location of all instruments; survey control points; surface monitoring points; and survey schedules, procedures, and reporting formats.
- D. Drill logs: Boreholes are to be logged under the supervision of a geologist or engineer with a minimum of three (3) years of experience. Logs shall be on an accepted format and include the depth, angle and orientation of hole, station and offset from the trenchless installation, trenchless installation description, geologic log, and notes of any inflows of water or other material, if encountered.
- E. Installation:
1. Provide notice to the Engineer not less than five (5) work days before inclinometer installation and not less than one (1) work day for all other instrument installations. Label all instruments with the same identifying instrument number as shown on the Contract Documents or in a manner acceptable to the Engineer.
 2. Installation Tolerances: Position all instruments within 12 inches of the horizontal location as specified herein. Position instrumentation to within 6 inches of the bottom elevation or deeper as specified herein. Position settlement monitoring points and instrument casings to the more restrictive of two degrees of vertical for the entire depth of each instrument or as required by the manufacturer.
 3. When actual field conditions prevent installation of instruments at the location and elevations specified herein, obtain prior acceptance from the Engineer for new instrument location and elevation.
 4. Shop Drawings: Show installed locations, the instrument identification number, the instrument type, the installation date and time, established elevations, initial elevations, offset and stationing, initial coordinates and boring log, and the anchor to tip elevation and instrument length, when applicable. Shop drawings include as-built shop drawings showing each instrument including installation records, depths, lengths, elevations, and dimensions of all key elements.
 5. Perform a baseline reading for each instrument which shall include at least two readings from each instrument before commencing underground construction. The two readings are to be completed on two different work days each requiring a separate set-up. The readings are to provide

statistically valid reproducible results allowing for temperature adjustments to both atmosphere and facility. If results are not valid, perform additional daily readings or re-install instrument until readings are reproducible. Baseline Readings of all monitoring devices shall be conducted by or with the supervision of the Contractor's Geotechnical Instrumentation Specialist in strict accordance with manufacturer's recommendations or as approved in the Geotechnical and Structural Monitoring Plan. The Contractor shall repeat baseline readings if the submitted baseline readings are taken or interpreted in a manner not to the satisfaction of the Engineer.

- F. Inclinometers shall be functional to a depth of at least 20 feet below the top of working pad of the shaft shaft sidewall.
- G. Surveys for monitoring geotechnical instrumentation shall be referenced to the same control points and benchmarks established for setting out the work. Control points shall be tied to benchmarks and other monuments outside of the zone of influence of the underground excavations.

1.6 SUBMITTALS

- A. Submittals shall be made in accordance with General Conditions and as specified herein.
- B. Submittals shall be coordinated with all relevant submittals, assembled and submitted as a single, comprehensive submittal.
- C. Where calculations are required to be submitted, they shall be signed and sealed by a Professional Civil Engineer registered in the State of Colorado. Calculations shall clearly identify all parameters used, state all assumptions made in the calculation, and identify all sources of information.
- D. All shop drawings shall be legible with dimensions accurately shown and clearly marked in English units.
- E. Provide written notification to the Engineer within one work day in the event of damage or malfunctioning of any instrument, or when an instrument trigger level is attained.
- F. Preconstruction submittals:
 - 1. Name and qualifications for the following:
 - a. Geotechnical Instrumentation Specialist.
 - b. Technicians.
 - c. Surveyors.
 - d. Drillers.
 - 2. Sample drilling logs for instrumentation drilling.
 - 3. Description of water source for drilling and installation of inclinometers and

- piezometers.
4. Inclinometer calibration records dated no more than 6 months prior to the date the instrument will first be used for this project.
 5. Schedule for installation of survey control points as specified herein or at least two (2) weeks prior to installation.
 6. Site specific shop drawings indicating the layout and designation of all control points and monitoring points as specified herein and as shown on the Contract Documents
 7. Description of the survey control point installation procedure.
 8. Description of the proposed methods for monitoring each instrument type as specified herein.
 9. All instrument manufacturer's product data at least two (2) weeks prior to installation.
 10. All permits required for instrument installation.
 11. Contingency plan in the event ground movement reaches the prescribed Trigger Values as specified herein.
 12. All instrument baseline readings. Submit results within two (2) work days following readings and not less than three (3) work days preceding the commencement of excavation.
 13. A survey grid establishment for monitoring ground surface movement (settlement or heave) during construction must be submitted to and approved by CDOT as per CDOT encroachment permit requirements
 14. Sample data presentation formats for each monitoring device.
- G. Construction submittals
1. Drilling logs for instrumentation installations within five (5) work days of drilling.
 2. Shop drawings and as-builts within a minimum of five (5) work days following installation of each instrument.
- H. Submit reduced data and updated data plots of reading results by noon of the following day after observation readings are made. Data is to be submitted in an electronic format that can be manipulated as acceptable to the Engineer.
- I. The monitoring records shall be presented in both data table format and cumulative time history trend plots. The records shall be submitted in an electronic format

acceptable to the Engineer. The monitoring record in both data table and graphs form shall clearly report the following:

1. Locations and identification of the monitoring devices.
 2. Data and time readings and personnel who conducted the monitoring.
 3. Conditions under which the readings are taken including progress of construction activities, weather conditions, and note any potential factors that may have affected the readings.
 4. Instrument readings, both absolute and differential values from the corresponding baseline readings, and the trigger levels specified herein. All plots shall be differentiated using a combination of varying line types, data point symbols, or colored lines.
- J. Notify and meet with the Engineer as specified herein when the trigger value is reached for any geotechnical instrument.
- K. Post-Construction submittals:
1. Signed and sealed cumulative records and interpretations within 4 weeks following instrument removal including an as-built survey-grid showing all instruments as required by CDOT encroachment permit.
 2. Record of legal destruction of instruments within 4 weeks of instrument removal.

1.7 PROJECT/SITE CONDITIONS

- A. Secure applicable permits and secure permission from property owners for access for the installation of monitoring systems.
- B. See project geotechnical report titled Geotechnical Investigation, Persigo Outfall Project, prepared by Huddleston Berry, dated October 10, 2017 for subsurface ground information.

PART 2 - PRODUCTS

2.1 MATERIALS

- A. Sand: Compatible with manufacturer's written recommendations and ASTM C778.
- B. Cement: Shall be Type II Portland cement and water in accordance with ASTM C150 and compatible with instrument manufacturer's written recommendations.
- C. Water: Potable.
- D. Bentonite Chips: Shall be Enviroplug Medium manufactured by Wyo-Ben, Inc., Billings, MT, or Holeplug, as manufactured by Baroid Division, Petroleum Services, Inc., Houston, TX, or acceptable equivalent.

2.2 EQUIPMENT AND ANCILLARY CONSTRUCTION MATERIALS

- A. Provide as shown on the Contract Documents, specified herein, and acceptable to the Engineer.
- B. Utility Monitoring Points (UMPs): Provide sensor with accuracy of at least ± 0.01 foot.
- C. Inclinometers:
 - 1. An inclinometer system consists of: casing installed in a borehole; inclinometer probe, cable, and casing pulley assembly; data collection/readout unit and data processing software. The inclinometer casing is a special purpose, grooved pipe typically installed in boreholes. The inclinometer probe is lowered into the casing attached to the special cable and drawn upwards from the bottom in two passes to measure lateral movement.
 - 2. Inclinometer Casing: Inclinometer casing shall be approximately 2.75-inch standard flush coupled type Model No. 51101100 manufactured by Slope Indicator Company, Seattle, WA; Model No. 6000 manufactured by Geokon, Inc., Lebanon, NH; or approved equal. Each casing shall be furnished with a bottom cap with grout port connection, top cap, and a protective housing with locking cap that are compatible with the casing furnished. Couplings and accessories necessary for the installation and operation shall be provided as recommended by the manufacturer.
 - 3. Inclinometer Probe and Assembly: One inclinometer probe and assembly shall be furnished including a sensor (probe) on a minimum 30-foot-long cable, a pulley assembly, cable reel, and a case. Equipment shall be Model No. 50302500 (sensor), and associated pulley assembly and case manufactured by Slope Indicator Company, Seattle, WA; Model No. 6000 Inclinometer System manufactured by Geokon, Inc., Lebanon, NH; or approved equal. Furnish a carrying case. An identical backup

probe shall be available onsite or be obtainable within 24 hours.

4. **Inclinometer Readout Unit:** One inclinometer readout unit shall be furnished. The readout unit shall be Model No. 50310900 manufactured by Slope Indicator Company, Seattle, WA; Model No. GK-603 manufactured by Geokon, Inc., Lebanon, NH; or approved equal. Readout unit provided shall be compatible with inclinometer probe and shall be calibrated by manufacturer prior to shipment.
 5. **Inclinometer Software:** Computer software required to reduce, analyze, and plot the inclinometer data using a personal computer (PC) running Windows shall be furnished. DigiPro software program by Slope Indicator Company, Seattle, WA; INCIBM/INCTAN software by Geokon, Inc., Lebanon, NH; or equal shall be furnished.
 6. **Grout:** Neat cement grout shall be provided for installing inclinometer casing within drill hole. Grout mix shall be in accordance with manufacturer's requirements.
- D. **Settlement Monitoring Points (SMPs):** Provide sensor with accuracy of at least ± 0.01 foot.
- E. **Piezometer:**
1. Piezometers consist of hydraulic pressure sensors capable of providing automatic, continuous measurement of groundwater levels with an electronic data logger.
 2. Piezometer: shall be Model 4500AL with sensor accuracy of at least ± 0.1 foot as manufactured by Geokon, Inc., Lebanon, NH; or approved equal.
 3. Datalogger: shall be Model 8002 LC-2 Piezometers shall provide fully automatic, continuous recording and reporting capabilities using the data loggers, and shall be suitable for installation in a borehole or in an observation well. Data logger shall be compatible with piezometer instrumentation.
 4. Readout Unit: shall be Model Geokon Model GK-404 or approved equal. The readout unit shall be from the same manufacturer as piezometer.
 5. Piezometer: shall be installed with borehole sealed with alternating layers of sand, bentonite chips and neat cement grout as shown on Contract Documents.
 6. Borehole shall be drilled either without drilling mud or with a material that degrades rapidly with time such as Revert manufactured by Johnson Screens, Inc., Houston, Texas. Bentonite shall not be used in drilling mud.

PART 3 - EXECUTION

3.1 GENERAL

- A. Perform all Work in accordance with accepted submittals, and manufacturer's recommendations.
- B. The Contractor shall obtain and comply with all applicable permits required for installation of instruments.
- C. Provide the Engineer and the City with access to the instrument locations.
- D. Installation of the instrumentation by the Contractor does not preclude the City, through an independent Contractor, from installing instrumentation in, on, near, or adjacent to the construction work.
- E. Maintain a copy of the Contract Documents in a location acceptable to the Engineer and accessible to the geotechnical instrumentation specialist and the Engineer.
- F. Treat and dispose of all water in accordance with the requirements specified in Section 01130.
- G. Dispose of contaminated ground in accordance with General Conditions.
- H. Ensure each instrument is functional for its intended purpose and installed in manner that protects the general public from injury.
- I. Install all instruments a minimum of ten (10) work days prior to start of excavation unless specifically stated otherwise.
- J. Perform baseline readings as specified herein.
- K. Markings for each instrument identifying instrumentation name, location, and numbering shall be refreshed weekly or more frequently if necessary to ensure legible visibility of its location and unique identifier marking at all times during project duration.
- L. Locate all utilities in accordance with General Conditions before commencing drilling. Avoid drilling into or damaging conduits and other underground facilities or utilities.
- M. Obtain permits as required for instrumentation installation.
- N. Drill, grout and dispose of resultant spoils.
- O. Prepare bore log of as-built instrument.
- P. Prepare ground and surfaces for instrument installation and testing.
- Q. Monitor instrumentation; provide data to Engineer in a timely manner as specified

herein.

- R. Perform visual observation of the ground surface during construction operations and note observations and changes.

3.2 SURVEY

- A. Adhere to General Conditions and to the following requirements concerning survey oversight:
 - 1. Perform initial survey and record the horizontal coordinates and elevations within an accuracy of 0.005 feet (1/16 inch) for each survey point location and all subsequent surveys. Reference survey points so that they are accurately re-established if lost or destroyed.
 - 2. Perform interim surveys and commence readings at the commencement of shaft and tunnel excavation at the frequency specified herein.
 - 3. Continue to monitor ground movements until one week after completion of construction or until the movement ceases, whichever is longer. Then perform a final survey, with two readings similar to the initial survey, of all control points and instruments. Submit final readings as specified herein.

3.3 DRILLING, GROUTING, PREPARATION, ACCESS AND PROTECTION

- A. Drill holes of appropriate size and depth in concrete and asphalt and cased holes in fills and ground for installation of instruments on private buildings. A written agreement prior to drilling holes for installation of instruments must be obtained from owners.
- B. Clean holes to remove debris. Holes which the Engineer considers unsatisfactory because of misalignment or other irregularities shall be re-drilled as directed by the Engineer.
- C. Withdraw the casing or auger without rotation so as to prevent ground collapse into the excavated hole.
- D. Provide access and temporary facilities, such as power and sufficient general area lighting necessary for installing instruments.
- E. Mix grout using equipment capable of thoroughly mixing grout material so that grout is of uniform consistency with no unsuspected solids. Place grout using a tremie method, where applicable, with side discharge ports on tremie pipe.
- F. Protect instrumentation from damage during construction and from public, and maintain instruments and components. Repair or replace damaged instruments and components to the satisfaction of the Engineer. Notify Engineer of any damage or instrument malfunctioning as specified herein.

3.4 UTILITY MONITORING POINTS (UMPS)).

- A. Provide one (1) UMP for each utility crossed by the trenchless methods.
- B. Remove pavement over utility by coring or cutting. Minimize area of pavement removal.
- C. Excavate to top of utility using vacuum truck, hand auger, or other suitable method. Do not damage utility during excavation.
- D. Construct temporary casing, trench box, or similar protective equipment as required to provide safe support and access for installation of point.
- E. Construct bar and pipe riser to protect the UMPs. Maintain centralized alignment throughout installation. Do not allow the bar to contact the inside of the riser pipe.

3.5 INCLINOMETERS

- A. Provide inclinometers, at least one adjacent to each shaft as shown on the Contract Drawings.
- B. Inclinometer installation and monitoring shall be in accordance with ASTM D6230.
- C. Inclinometer installations shall be completed at least ten (10) work days in advance of starting adjacent excavations.
- D. Provide a traffic-rated 6-inch ID steel monument at each installation location.

- E. Drilling operations shall be conducted using appropriate methods that are consistent with anticipated geologic conditions per project geotechnical report titled Geotechnical Investigation, prepared by Huddleston Berry, dated October 10, 2017

3.6 SETTLEMENT MONITORING POINTS (SMPS)

- A. SMPs shall be located as shown on the Contract Documents.
- B. Grout the casing housing so it is in intimate contact with the ground.
- C. Furnish, install, monitor and remove following construction up to 6 additional surface monitoring points at locations to be determined in the field by the Engineer.

3.7 PIEZOMETERS

- A. Provide piezometers as shown on the Contract Documents.
- B. Each piezometer shall be installed with readout cables extending to 2 feet above ground and housed with data logger in a casing flush with the ground and protected for the duration of the Project.
- C. Provide a traffic-rated 12-inch ID steel monument at each installation location.

3.8 MONITORING

A. Frequency: As a minimum, follow the following schedule to determine frequency and duration of the monitoring:

Instrument Type	Monitoring Frequency	
Inclinometers	Daily	
Settlement Monitoring Point (SMP)	Daily	
Piezometer	Continuous	

Note: The Contractor shall continue monitoring of instruments till one (1) week after construction or if movement continues, whichever is longer.

- B. The Contractor shall perform additional monitoring as necessary to control construction and to ensure the safety of the work.
- C. Interpretation: Data or interpretation shall not be published or disclosed to other parties without advance written permission of the City. Provide instrument readings and interpretations of monitoring data to the Engineer within the times specified herein.

3.9 TRIGGER VALUES

A. Instrument Trigger Values:

Instrument	Threshold Value	Response Value	Shutdown Value
Settlement Monitoring Point	0.5 inch	0.8 inch	1 inch
Inclinometer	0.25 inch	0.5	1 inch

- B. When a given Instrument Trigger Value is reached, the Contractor shall provide verbal notice within one hour upon occurrence, confirming written notice within 1 work day, and respond in accordance with the following:
 - 1. Threshold Value: Meet with the Engineer within 24 hours of providing notice to discuss means and method to determine what changes, if any, shall be made to better control ground movement. Instrument readings shall be made on a daily basis until five consecutive work days of readings remain unchanged; at which point the readings will revert to the reading frequency specified herein.
 - 2. Response Value: Meet with the Engineer within 24 hours to discuss means and methods to determine what changes shall be made to better control ground movement. Actively control ground movement in accordance with the accepted plan to prevent reaching the Shutdown Value. Instrument readings shall be made on a daily basis until five consecutive work days of readings remain unchanged; at which point the readings will revert to the reading frequency specified herein.
 - 3. Shutdown Value: Stop all work immediately. Meet with the Engineer within 1 day to develop a plan of action before any work resumes.
- C. All measured deflection values are relative to the baseline value identified at the start of construction. Baselines shall not be reset after each bore and shall remain the same for the duration of this Contract.
- D. The required responses specified herein shall apply to any visualization of ground or structure movement between monitoring points including sinkholes, ratholes, and other visual forms of movement.
- E. Action Plan Workshop: At least fifteen (15) work days before start of construction, Contractor shall schedule an action plan workshop to inform and train assigned project staff of requirements and actions to be taken when monitored parameters are reaching trigger levels, as defined herein. The workshop shall be attended by the Engineer and the Contractor shall inform the Engineer of the workshop schedule at least ten (10) work days prior to the workshop.

3.10 REMOVAL AND SITE RESTORATION

- A. Obtain written approval from Engineer that instrumentation is no longer required.
- B. Remove the instrument prior to substantial completion of the work, unless otherwise indicated.
- C. Remove and/or abandon the instrumentation in accordance with the permit.
- D. Backfill surface excavations with unshrinkable fill, when within apron, roadways or sidewalks, and with selected fill when outside of such areas up to the underside of surface restoration. Steel casings, if any shall be removed to a minimum depth of five (5) feet below ground surface.
- E. Surfaces affected by installation of instruments shall be restored to their original

condition prior to completion of work.

****END OF SECTION****

PART 1 - GENERAL

1.1 SUMMARY

- A. Section includes:
 - 1. Aggregate base or surfacing for roadways.
- B. Related sections include but are not limited to:
 - 1. Division 0- Bidding Requirements, Contract Forms, and Conditions of the Contract.
 - 2. Division 1- General Requirements.
 - 3. Division 2 - Site Work.

1.2 MEASUREMENT AND PAYMENT

- A. Aggregate Base Course
 - 1. No measurement or direct payment will be made for aggregate base course for roads, the cost of this work shall be included in Item 15074.

1.3 QUALITY ASSURANCE

- A. Referenced Standards
 - 1. American Association for Testing and Materials (ASTM).
 - a. C535, Standard Test Methods for Resistance to Degradation of Large-Size Coarse Aggregate by Abrasion and Impact in the Los Angeles Machine.
 - b. D698, Standard Test Methods for Laboratory Compaction Characteristics of Soil Using Standard Effort.
 - c. D1557, Standard Test Methods for Laboratory Compaction Characteristics of Soil Using Modified Effort.
 - d. D2922, Standard Test Methods for Density of Soil and Soil-Aggregate-In- Place By Nuclear Methods (Shallow Depth).
 - e. D3017, Standard Test Methods for Moisture Content of Soil and Soil-Aggregate-In-Place Nuclear Methods (Shallow Depth).

PART 2 - PRODUCT

2.1 MATERIALS

- A. Aggregate Surfacing
 - 1. Crushed Gravel or Crushed Rock.

- a. Angular, hard, dense, durable particles, free from vegetable matter, lumps or balls of clay, and other deleterious substances, crushed and graded uniformly to meet the grading requirements, by weight, as determined by laboratory sieves, shown in Table 1.

Table 1

Sieve Size	Percent by Weight Passing Sieve Size
1 1/8-inch square mesh sieve	100
No. 4-mesh sieve	38 to 65
No. 8-mesh sieve	25 to 60
No. 30 mesh sieve	10 to 40
No. 200-mesh sieve	5 to 15

- b. Material passing the No. 40-mesh sieve shall have a liquid limit of not more than 30 and a plasticity index of 4 to 9. The lower plasticity index limit may be waived if the fractured faces are 100% or more as determined in Section d. below or the minus No. 8 fraction has a dry unconfined compressive strength greater than 200 psi.
- c. Fractured Faces - Not less than 65% by weight of the particles retained on the No. 4 sieve shall have at least one manufactured face.
- d. The Los Angeles Abrasion loss shall not exceed 50% when tested in accordance to ASTM C535 at 500 revolutions.

B. Aggregate Base

1. Crushed Gravel or Crushed Rock

- a. Angular, hard, dense, durable particles, free from vegetable matter, lumps or balls of clay, and other deleterious substances, crushed and graded uniformly to meet the grading requirements, by weight, as determined by laboratory sieves, shown in Table 2.

Table 2

Sieve Size	Percent by Weight Passing Sieve Size
1 1/8-inch square mesh sieve	100
No. 4-mesh sieve	38 to 65
No. 8-mesh sieve	25 to 60
No. 30 mesh sieve	10 to 40
No. 200-mesh sieve	3 to 12

- b. Material passing the No. 40-mesh sieve shall have a liquid limit of not more than 25 and a plasticity index of not more than 6.
- c. Fractured Faces - Not less than 65 % by weight of the particles retained on the No. 4 sieve shall have at least one manufactured face.
- d. The Los Angeles Abrasion loss shall not exceed 50% when tested in accordance to ASTM C535 at 500 revolutions.

PART 3 - EXECUTION

3.1 CONSTRUCTION REQUIREMENTS

A General

- 1. General: Prepare the surface that the aggregate course is to be placed upon according to ASTM D698 and Section 02934.

B. Mixing and Spreading.

- 1. Provide an aggregate and water mixture suitable for compaction. Spread the mixture on the prepared surface in a uniform layer. Do not place the mixture in a layer exceeding four (4) inches in compacted thickness. When more than one layer is necessary, shape and compact each layer before the succeeding layer is placed. Route hauling equipment uniformly over the full width of the surface to minimize rutting or uneven compaction. Shape the final layer to line, grade, and typical section.
- 2. Prior to spreading, uniformly mix the aggregate and bring it to within 2% of optimum moisture content.

C. Compacting.

- 1. Compact each layer full width. Roll from the sides to the center, parallel to the centerline of the road. Compact each layer of aggregate to not less than 95% of maximum density. Along curbs, headers, walls, and all places not accessible to the roller, compact the material with approved tampers or compactors.
- 2. Use ASTM D1557, Method D to determine the maximum density. Use ASTM D2922, and ASTM D3017, or other approved test procedures to determine the in-place density and moisture content.

D. Finishing

- 1. During finishing operations remove all material larger than 6 inches within the top 3 inches of the finished grades. Remove unsuitable material from the roadway finished grades and replace with suitable

material. Finish the roadway subgrade and ditches to match existing elevations.

- E. Surface Tolerance.
 - 1. Use a 10 ft straightedge to measure the final surface at designated sites. A defective area is an area with surface deviations in excess of 0.50 inch. Correct all defective areas by loosening the material, adding or removing material, reshaping, and compacting.
 - 2. Tolerances for Finished Grades:

Table 3

Staking Phase	Horizontal (ft.)	Vertical (ft.)
Typical Sections, Slope Stakes, and Slope Stake References	+/- 0.2	+/- 0.1
Roadway Subgrade Finish Stakes	+/- 0.2	+/- 0.03

- F. Maintenance.
 - 1. Maintain the aggregate course to the correct line, grade, and typical section by blading, watering, rolling or any combination thereof until placement of the next course. Should irregularities develop in any surface during or after compaction, loosen the surface and correct defects. Recompact the disturbed area.

PART 4 - ACCEPTANCE

4.1 ACCEPTANCE

- A. Untreated aggregate course gradation, construction, and other aggregate quality properties will be accepted under measured and tested conformance.
- B. The point of acceptance sampling for testing shall be from the windrow of the roadbed after processing. Gradation, liquid limit, plastic index and density tests shall be performed on each 1,000 tons placed.

END OF SECTION

SECTION 02621

SHAFT CONSTRUCTION

PART 1 - GENERAL

1.1 REQUIREMENTS

- A. This Section includes design and construction parameters for the Contractor-designed watertight temporary support of excavation for shaft construction.
- B. Shoring refers to providing all components of the excavation support system, including, but not limited to piling, bracing, struts, wales, or any other support. Use other methods of support only when approved by the Engineer. Shoring shall be designed, provided, maintained, and where applicable, removed by the Contractor, in accordance with this Section and the Contract Documents.
- C. As required by OSHA and in addition thereto, whenever work under the contract involves the excavation of five (5) feet or more in depth, including temporary construction pits, shaft and manhole excavations, the Contractor shall submit to the Engineer a detailed plan showing the design of shoring, bracing, sloping, or other provisions to be made for worker protection from the hazard of caving ground during the excavation of such trench or trenches. If such plans vary from the shoring system standards established by OSHA, the plans shall be prepared and signed by a registered civil or structural engineer employed by the Contractor.
- D. Shoring system plans for pits or other large excavations in excess of five (5) feet or more in depth shall be prepared and signed by a civil or structural engineer, registered in Colorado and employed by the Contractor. All costs therefore shall be included in the bid price named in the contract for completion of the work as set forth in the contract documents.
- E. Nothing in this Section shall be deemed to allow the use of a shoring, sloping or other protective system less effective than that required by the Construction Safety Orders or Tunnel Safety Orders. Nothing in this Section shall be construed to impose tort liability on the City, Design Consultant, or any of their officers, agents, representatives, or employees.
- F. Horizontal strutting below the barrel of a pipe and the use of pipe as support are not acceptable.
- G. The Contractor shall assume sole responsibility for developing the dimensions of the shaft / pit to accommodate for the construction method, planned construction operations, carrier pipe installation and/or fusing, right of way and easement limitations, and surface and underground drainage inflow.
- H. The Contractor may elect to submit an alternate support of excavation system than described in the technical specifications. The Contractor shall submit the alternate

design and include the watertight support of excavation design that is subject to the review of the Engineer. The Contractor shall provide specifications and standards to accompany the alternate support of excavation method.

- I. The sheeting, shoring, and bracing system shall be designed and constructed to meet all of the following minimum performance requirements:
 1. Protect personnel that enter excavations.
 2. Assure worker safety and optimal conditions for pipe installation.
 3. Protect adjacent existing utilities, pipelines, pavements, and structures.
 4. Installation of support system shall not cause settlement or heave of the ground surface nor produce construction vibrations that could damage adjacent utilities or structures.
 5. Prevent lateral movement of excavation walls and associated loss of adjacent ground support and adjacent ground lateral shifting/settlement.
 6. Prevent heaving of the excavation bottom.
 7. When removal is permitted, allow for the removal of support system in a manner that does not damage the pipeline, cause settlement or heave of the ground surface, nor produce construction vibrations that cause damage to adjacent utilities or structures.

1.2 REFERENCE SPECIFICATIONS, CODES, AND STANDARDS

- A. Comply with the following reference Specifications
 1. General Conditions
 2. Section 01130, Dewatering
 3. Section 2356, Steel Sheet Piling
 4. Section 02316, Pipe Ramming
 5. Section 02440, Pipe Jacking
 6. Section 02445, Instrumentation and Monitoring
 7. Section 02623, Microtunneling
 8. Section 03610, Ground Pre-Treatment

9. Section 02356, Steel Sheet Pile Shafts
 10. Section 3200, Concrete Reinforcement
 11. Section 3300, Cast-in-Place Concrete
 12. Section 3610, Ground Pre-Treatment
- B. Comply with the following industry standards effective at time of bid:
1. 29 CFR Part 1926 Occupational Safety and Health Administration (OSHA) Regulations and Standards for Underground Construction.

QUALITY CONTROL

- A. Comply with General Conditions.
- B. Designs and Calculations - Prepared, stamped, sealed and signed by a Civil or Structural Engineer who is registered in the State of Colorado.
- C. Design excavation support in accordance with the criteria indicated and specified.
- D. Welding operations - In accordance with AWS D1.1 and Basic Welding Requirements.
- E. Do not perform welding before welding procedures and welder operator qualifications are approved by the Engineer.
- F. Reference Standards
 1. American Petroleum Institute (API)
 - a. API SPEC 13A Drilling Fluid Materials
 2. American Welding Society (AWS)
 - a. AWS D1.1 Structural Welding Code – Steel

1.3 QUALITY ASSURANCE

- A. Work of this Section shall be performed by an individual or firm of established reputation (or, if newly organized, whose personnel have previously established a reputation in the same field) for at least five (5) years, which is regularly engaged in, and which maintains a regular force of workmen skilled in design, installation and maintenance of shoring.
- B. All welding shall be done by skilled welders, welding operators, and tackers who have had adequate experience in the type of materials to be used. Welders shall be qualified under the provisions of ANSI/AWS D1.1 by an independent local

approved testing agency not more than six (6) months prior to commencing work; unless having been continuously employed in similar welding jobs since last certification. Machines and electrodes similar to those used in the work shall be used in qualification tests. The Contractor shall furnish all material and bear the expense of qualifying welders.

1.4 CONTRACTOR SUBMITTALS

- A. Refer to Section 02356 – Steel Sheet Pile Shafts
- B. Submittals shall be made in accordance with General Conditions, Section 02316, Section 02440, Section 02623, and as specified herein.
- C. Shaft submittals shall be coordinated with all relevant submittals, assembled and submitted as a single, comprehensive submittal.
- D. Shop Drawings
 - 1. Submit plans for shoring to the Engineer for review at least ten (10) working days prior to commencement of work. No excavations shall be started until the Engineer has reviewed the Contractor's shoring design. The shoring and bracing system plans shall be in accordance with the Contract Documents and to permit the Engineer to review the overall completeness and effectiveness of the proposed system. Review of the shoring and bracing plans by the Engineer in no way relieves the Contractor of complete responsibility for providing effective and safe shoring and bracing of the construction area and/or pipeline under construction.
 - 2. Include:
 - a. Design assumptions, analyses, calculations, and information on Contractor's proposed method of installation and removal of shoring as specified. The design and calculations shall be performed by, sealed and signed by a professional engineer registered in the State of Colorado and experienced in the design of earth retaining structures.
 - b. The maximum design load to be carried by the various members of the support system.
 - c. Loads on support system for various stages of excavation, bracing removal and concrete placement.
 - d. Expected equipment loads including the crane, pipe storage, and temporary dead and live loads.
 - e. Maximum design load carried by various members of support system, and preload values.
 - f. Detailed excavation support drawings, showing all pertinent dimensions, spacing, and relationships among the components of the shoring, as well as construction sequence and scheduling.
 - g. Details, arrangement and method of assembly and disassembly of proposed system and sequence of construction.

- h. The method of preload bracing and bracing during excavation.
 - i. The full excavation depth and the planned depth(s) below the main excavation to which the support system will be installed.
 - j. Detailed sequence of construction and bracing removal and backfilling.
 - k. Methods of resolving difficulties arising from misalignment of sheet piles exposed during excavation, and criteria for implementing procedures.
 - l. Detailed drawings and descriptions of the method to be used by the Contractor to monitor shoring and adjacent ground/structure movements.
 - m. Description of layout and use of interior sump pumps.
 - n. Calculations demonstrating that shoring design can accommodate for hydrostatic pressures without external dewatering wells permitted to draw down the groundwater level behind the shoring.
 - o. Contingency plan for joint leakage with excessive inflow.
 - p. Contingency plan encountering obstructions while installing excavation support systems.
 - q. Quality Control Submittals
3. Submit proof of experience and qualifications required in this Section.
- E. Certified test results and welder certifications in accordance with AWS.
- F. Certificates of Compliance for materials specified in Products.
- G. Manufacturer's product data.
- H. Where calculations are required to be submitted, they shall be signed and sealed by a Professional Civil Engineer registered in the State of Colorado. Calculations shall clearly identify all parameters used, state all assumptions made in the calculation, and identify all sources of information.
- I. Permits
- 1. Contractor shall have up to date OSHA construction activity permit for Trench and Excavation construction.
- J. Meetings
- 1. Contractor shall coordinate and attend the OSHA preconstruction Tunnel Safety Order for Tunneling and shaft construction.

1.5 SAFETY

- A. It is the Contractor's responsibility to determine if a tunneling permit for the Project is required and secure one if necessary. The Underground Classification Notice shall be conspicuously posted at the jobsite. Perform Work in conformance with the underground classifications.
- B. Train all non-Contractor project staff in entry operations prior to entry.

1.6 PROJECT CONDITIONS

- A. For geotechnical information refer to "Geological Hazards and Geotechnical Investigation Persigo Wastewater Treatment Plant Outfall Grand Junction, Colorado, Project # 01543-0001 dated October 10, 2017.
- B. Site specific data:
 - 1. Test Pit TP-1 as reported in the Geological Hazards and Geotechnical Investigation Persigo Wastewater Treatment Plant Outfall was dug in September of 2017 to a depth of 13 feet in the center median of I-70. Material in TP-1 was Gravelly Clay with Cobbles to Clayey Sand with Gravel for the first 5 feet with Sandy Gravel and Cobbles below 5 feet. Cobble sizes of up to 12 inches were observed. The material exhibited characteristics of flowing, non-cohesive, non-plastic soils in accordance with the Tunnelmans Ground Classification. Groundwater was observed at a depth of 9 feet. Surface elevation is approximately 4514 above mean sea level.
 - 2. Test Pit TP-2 as reported in the Geological Hazards and Geotechnical Investigation Persigo Wastewater Treatment Plant Outfall was dug in September of 2017 to a depth of 10 feet approximately 20 feet north of westbound of I-70 at a location approximately equal to the receiving shaft. Material in TP-2 was Clayey Sand with organics for the first 2 feet where it transitioned to Clayey Sand with gravel to a depth of 7 feet. Below that elevation was observed to be Sandy Gravel and Cobbles. Cobble sizes of up to 12 inches were observed. The material exhibited characteristics of flowing, non-cohesive, non-plastic soils in accordance with the Tunnelmans Ground Classification. Groundwater was observed at a depth of 8 feet. Surface elevation is approximately 4514 above mean sea level.
- C. For baseline purposes, the anticipated ground conditions along the trenchless alignment indicated on the Contract Drawings are baselined as the following.
 - 1. Soils at the proposed horizon of the trenchless alignment will consist of flowing to running ground, non-cohesive sandy gravel and cobbles (GP)
 - 2. Full face of non-cohesive materials that will fast ravel and flow when not adequately supported at the face.
 - 3. Granular materials will be encountered during the launching, receiving and tunnel excavation. Direct communication with the Colorado River and nearby tributaries will exhibit flowing behavior when not adequately supported or dewatered.
 - 4. The relative percentage of non-cohesive materials such a sand, gravel and cobbles will be more than 95% within the tunnel zone.

5. Cobbles, as defined ASTM D2487 – USCS, are the coarsest material to be encountered during excavation along the alignment shown on the Contract Drawings. Nested cobbles are expected along the tunnel alignment.
 6. Non-cohesive materials will cause excessive abrasion and wear to the tooling used for excavation.
 7. Approximately 5% or less fines are to be encountered along the within the tunnel zone.
 8. The upper five (5.0) feet of ground cover shall be assumed to be artificial fill material. Asphalt and aggregate are anticipated under the Interstate 70. A maximum of 30% of the bank volume of the excavated fill material will contain cobble-sized material.
 9. As stated in the Geotechnical Exploration Report, groundwater level varies along this alignment. The groundwater is influenced by the water surface in the Colorado River and may be higher or lower during construction.
 10. For design purposes, groundwater levels will be at Elevation 4510 feet prior to be dewatering to allow for potential raised elevations.
- D. Engineered fill of unknown character, material, and engineering properties, may be present beneath the I-70 embankment to an unknown depth. For design purposes, soils at launch and reception shaft and within the proposed trenchless horizon, will be native. The optional intermediate shaft will contain approximately 5 to 8 feet of artificial fill.
- E. Existing Utilities
1. Contract Drawings do not show all utilities. Contractor shall notify 811 and field-check locations of utilities prior to commencing work. The Contractor shall protect any overhead wires and any sewer, water, gas, electric or other pipelines or conduits uncovered during work from damage caused by the work of this contract.
 2. Where utilities are anticipated or encountered unexpectedly, excavate by hand or other excavation methods acceptable to the utility owner.
 3. If existing utilities identified interfere with Contractor’s proposed method of support, any required modification or relocation shall be performed at no additional cost to the City.
 4. If existing utility facilities interfere with proposed method of excavation support, modify or relocate supports to avoid interference.

1.7 DESIGN CRITERIA

- A. The Contractor shall design a watertight shaft which accommodates for the design groundwater table without the use of any external dewatering.
- B. A concrete invert plug shall be designed to accommodate uplift forces with an appropriate factor of safety. The Contractor may elect to use a construct a tremie plug, which shall be placed underwater whereby the water head inside the shaft and the

- groundwater head outside the shaft are in equilibrium or temporarily remove water from the shaft using sump pumping methods from within the excavation. The contractor shall not cause settlement exceeding the limitations set forth in the Contract Documents.
- C. The Contractor shall plan and design the launching and receiving shafts to require ground pre-treatment. The zone of soil improvement shall extend the full length of the trenchless construction equipment as a minimum.
 - D. The Contractor shall include in the bid price repair or mitigation of leaking or non-watertight joints during installation. Additional localized target grouting, sealants or repairs will be made at no additional expense to the owner.
 - E. The Contractor shall design the watertight shaft to resist uplift forces.
 - F. The Contractor shall design the shaft to accommodate mechanical seals for the launch and retrieval of the trenchless application selected.
 - G. The Contractor shall design and execute ground pre-treatment techniques for inflows in excess of 20 gallons per minute for the entire shaft construction volume for inflows through the shaft wall or upwelling in the invert.
 - H. The Contractor shall not plan on removing the support of excavation located directly under the steel casing. The Contractor shall plan on removing all support of excavation materials including walers, struts, sheet piles and accommodate of the adhesion of the clay properties, swelling potential and groundwater levels. The Contractor may elect to leave the support in place while removing the top 5 feet of the support of excavation materials at the discretion of the Engineer.
 - I. Design and construct the support of excavation system in accordance with all applicable codes, and in accordance with the specific requirements described herein.
 - J. At all times furnish, install, and maintain sufficient shoring and bracing in shafts / pits to insure safety of the workmen and to protect and facilitate the work. System shall be designed and constructed in accordance with the Contract Documents. The Contractor shall:
 - 1. Design each member or support element to support the maximum lateral earth pressures, hydrostatic pressures, lateral loads from traffic, construction equipment, and spoils loads that can occur during construction with appropriate safety factors.
 - 2. Take into account all surcharge loadings. Surcharge loadings can be due to such items as material or soil stockpiles, sloping ground adjacent to shoring, and adjacent building foundations. Contractor shall include the equipment surcharge loads in the design calculations. Contractor shall assure that his assumed conditions and loadings are not exceeded in the field during construction.
 - 3. Design the support system to prevent raveling, running, and flowing of excavation walls and associated loss of adjacent ground and adjacent ground surface settlement or existing trench material at utility crossings. Design the support system to retain non-cohesive granular soils subject to raveling, flowing, and/or running upon vibration from construction equipment

including compaction of backfill.

4. Prevent heave and/or piping (boiling) of the excavation bottom.
5. Design excavation support systems in accordance with all OSHA, requirements.
6. The design of shoring shall conform to accepted engineering practice in this field. The Engineer's approval of the Contractor's plans and methods of construction does not relieve the Contractor of his responsibility for the adequacy of this support.
7. The Contractor shall be solely responsible for, and bear the sole burden of cost for, any and all damages resulting from improper shoring or failure to shore and the resultant impacts on pavement, utilities, buildings and or structures.
8. The safety of workmen, the protection of adjacent structures, property and utilities, and the installation of adequate supports for all excavations shall be the sole responsibility of the Contractor.
9. The design, planning, installation, and removal, if required, of all shoring shall be accomplished in such a manner as to maintain stability of the required excavation and to prevent movement of soil and rock that may cause damage to adjacent shoring systems, structures and utilities, damage or delay the work, or endanger life and health.

PART 2 - PRODUCTS

2.1 MATERIALS

- A. Materials need not be new but shall be in serviceable condition as approved by the Engineer and shall be consistent with Contractor shop drawings and associated submittals with regard to types, sizes, lengths and other characteristics.
- B. Structural Steel for Secant Piles, Struts, Walers and Corner Bracing:
 1. HP shapes: ASTM A 572, Gr. 50.
 2. Channels, angles and plates: ASTM A 36.
 3. Wide flange: ASTM A 992.
 4. Hollow Steel Section: ASTM A500
- C. Concrete materials for Secant Piles:
 1. Portland Cement: ASTM C 150, Type I or II
 2. Fly Ash/Slag

- a. Fly Ash Admixture: ASTM C 618, Class C or F
- b. Ground Granulated Blast Furnace Slag: ASTM C 33, uniformly graded, 3/4 in maximum aggregate size.
3. Normal Weight Aggregate: ASTM C 33, uniformly graded, 3/4 in maximum aggregate size.
4. Water; Potable, complying with ASTM C 94 requirements.
- D. Water; Potable, complying with ASTM C 94 requirements.
- E. Admixtures: Certified by manufacturer to contain not more than 0.1 percent water soluble chloride ions by mass of cementitious material and to be compatible with other admixtures and cementitious materials. Do not use admixtures containing calcium chloride.
 1. Water-Reducing Admixture: ASTM C 494, Type A.
 2. Water Reducing and Retarding Admixture: ASTM C 494, Type D.
 3. High-Range, Water-Reducing Admixture: ASTM C 494, Type G.
 4. Plasticizing and Retarding Admixture: ASTM C 1017, Type II
- F. Concrete Mix: Prepare design mixes according to ACI 211.1 for each type and strength of concrete determined by either laboratory trial mix or field test data bases. Use a qualified testing agency for preparing and reporting proposed mix designs for laboratory trial mix basis. Proportion mixes according to ACI 211.1 to provide normal-weight concrete with the following properties.
 1. Structural concrete compressive strength (28 days): 4000 psi minimum
 2. Minimum Slump: Capable of maintaining a slump of 5 in plus or minus 1 in.
 3. Do not air-entrain concrete for secant piles.
 4. Limit water soluble, chloride-ion content in hardened concrete to 0.15/0.3 percent by weight of cement.
 5. Concrete-mix design adjustments may be considered if characteristics of materials, project conditions, weather, test results, or other circumstances warrant.
 6. Submission of proposed changes to concrete mix proportions is required.
 7. Concrete Mixing: Measure, batch, mix, and deliver concrete according to ASTM C 94, and furnish batch ticket information. Do not add water to concrete mix after mixing, unless a procedure following ACI 301 is submitted to, and approved by, the Engineer. Maintain concrete temperature less than 90 degree Fahrenheit.
- G. Bentonite shall conform to API SPEC 13A. Bentonite shall have the capability of mixing with water to form a stable and homogeneous suspension.

PART 3 - EXECUTION

3.1 EXAMINATION

Each soil and rock deposit shall be classified by a competent person. A ‘Competent Person’ is one who is capable of identifying existing and predictable hazards in the surroundings, or working conditions which are unsanitary, hazardous, or dangerous to employees, and who has authorization to take prompt corrective measures to eliminate them.”

- A. Verify Surface Conditions and utility locations. Protect utilities and improvements, as called for in the Contract Documents, or required by the Utility Company(s).
- B. Verify field measurements indicated on Drawings.
- C. Verify layout of work before beginning installation.

The Contractor shall conduct gas testing in accordance with OSHA standards. The Contractor shall follow all OSHA Tunnel Safety Orders stated herein.

3.2 EXCAVATION

- A. Protect or repair utilities damaged by operations of this Section. Protect adjacent structures and property from damage and disfiguration.
- B. Provide necessary groundwater control and drainage in accordance with the Contract Documents. Contractor shall expect that no dewatering will be permitted and placement of support will occur in soil under “wet” conditions and to prevent flowing, raveling, or running of soil, prior to shoring placement.
- C. The methods of constructing the temporary shoring are at the option of the Contractor and subject to review by the Engineer. Excavations shall be made to the lines, grade, and dimensions shown on the Contractor’s Shop Drawings. If the excavation is found to be deviating from the true lines and grade, the Contractor shall immediately make the necessary changes in operation to bring the operation back to the correct position. Any excess deviation beyond that specified herein shall be remedied by the Contractor at their own expense.
- D. All materials encountered shall be regarded as unclassified and shall be excavated, regardless of the nature thereof, and all excavated material must be removed and disposed of as described in the Contract Documents.
- E. Complete excavation in such manner as to provide adequate support at all times to adjacent conduits, structures, or roads and so as to offer no hazard to truck or automobile operations. Bracing and shoring shall be substantial and safe, and all work shall be done in full conformity and subject to the inspection of all affected parties. If and when required and to the degree necessary, the Contractor shall provide additional support as may be necessary at no additional cost.
- F. Take every precaution to prevent the entry of water, mud and foreign matter into the excavation at all times. It is the intention of these Specifications that all construction work described herein shall be carried out under wet conditions. The Contractor shall promptly and continuously control water inflow and dispose of all water from any source that may accumulate in the excavation via sump pumping only. This shall include all necessary pumping, bailing, draining and sedimentation prior to discharge.

- G. Any and all excess excavation or over-excavation performed by the Contractor for any purpose or reason, except as may be ordered in writing by the City, shall be at the expense of the Contractor. Any damage done to the work by the Contractor's operations shall be repaired by and at the expense of the Contractor and in a manner approved by the Engineer.
- H. Excavate only as much as can safely stand unsupported prior to installing shoring, but in no case more than two (2) feet shall be left unsupported at any time. Install support immediately after excavation.

3.3 REMOVAL OF SUPPORT SYSTEM/SITE RESTORATION

- A. After all equipment and excavated materials for the trenchless construction operations have been removed from the jacking shaft, the Contractor shall prepare the bottom of the shaft in the same manner as a pipe foundation, the Contractor shall remove all loose and disturbed materials below pipe grade to undisturbed ground and re-compact the material in accordance with Section 2300, Earthwork and Trenching. The installation of the sewer manholes near the ends of the trenchless portion shall be in accordance with the plans and specifications.
- B. The Contractor shall remove all support of excavation materials from the shaft /pit area once trenchless construction and installation is complete. The Contractor shall remove all materials with the exception of the approved backfill materials. The removal of the ground support system shall be performed in a manner that avoids ground settlement and damage to adjacent facilities. The Engineer may instruct additional remediation due to the settlement at no additional cost to the City if settlement occurs during or after installation/removal of the ground support system. The shafts shall be backfilled in accordance with the specification 02200.2.1. The Engineer may elect to leave the shoring and sheet piles in place if the Contractor cannot remove the support without creating settlement within acceptable limits.
- C. Site restoration shall be completed at all shaft locations restoring site to its original pre construction condition in its entirety.

3.4 SITE RESTORATION

- A. All surface improvements damaged or removed as a result of the Contractor's operations shall be reconstructed to the same dimensions, except for pavement thickness, and with the same type materials used in the original Work. Pavement resurfacing shall be one (1.0) inch greater in thickness than the existing unless otherwise shown on the Contract Documents.
- B. Restoration shall follow construction as the Work progresses and be completed no later than 30 days after the carrier pipe is installed. Any testing or further inspection necessary for final completion and inspection of the pipe shall not be cause for any delay of restoration Work required under this Contract. This

provision for restoration shall include all property that was affected by the construction operations. Such final restoration that cannot be performed within the 30-day period due to adverse weather conditions may upon written request, including a proposed procedure and time schedule, be performed as accepted by the Engineer. Any delayed restoration will be contingent upon providing suitable safe temporary facilities without inconvenience or nuisance in the interim.

- C. Clean and remove from the sewer system, obstructions, dirt, trash, debris, and other materials that will obstruct gravity flow.

****END OF SECTION****

SECTION 02623

MICROTUNNELING

PART 1 - GENERAL

1.1 REQUIREMENTS

- A. This section specifies minimum design and performance requirements for the construction of a gravity operated sewage effluent pipeline constructed using microtunneling, at the location indicated on the Contract Drawings.
- B. Furnish all designs, tools, equipment, materials, and supplies and perform all labor required to complete the Work as indicated on the Contract Documents and specified herein.
- C. Select, furnish, and maintain the microtunneling equipment in proper and safe working order.
- D. As part of the microtunneling work, the Contractor shall conduct all necessary ground improvement operations and protection and/or relocation of utilities and existing infrastructure as required to meet groundwater inflow and settlement criteria.
- E. All personnel assigned to work on the project where contaminated ground or groundwater is anticipated to be encountered shall be Hazardous Waste and Emergency Response Standard (HAZWOPER) certified in compliance with Division of Occupational Safety and Health (OSHA) regulations. Certifications shall be valid throughout the duration of the project

1.2 REFERENCE SPECIFICATIONS, CODES, AND STANDARDS

- A. Comply with the applicable reference Specifications:
 - 1. General Conditions
 - 2. Section 02315, Steel Casing
 - 3. Section 02445, Instrumentation and Monitoring
 - 4. Section 02621, Shaft Construction
 - 5. Section 02715, Carrier Pipe Installation into Casing
 - 6. Section 03360, Contact Grouting
 - 7. Section 03610, Ground Pre-Treatment
- B. Comply with the following industry standards effective at time of bid:
 - 1. NSF/ANSI Standard 060 – Drinking Water Treatment Chemicals – Health Effects.

2. NFPA 241 – Standard for Safeguarding Construction, Alteration, and Demolition Operations, current edition.
3. NFPA 70 – National Electric Code, current edition.
4. SSPWC “Green Book”, Standard Specifications for Public Works Construction
5. OSHA - U.S. Department of Labor, Occupation Safety and Health Administration, Construction Standards and Interpretations, 29 CFR Part 1926, Subpart S: Underground Construction; and Subpart P: Excavations.
6. ASTM D2487 - Standard Practice for Classification of Soils for Engineering Purposes (Unified Soil Classification System, “USCS”), current edition.

1.1 DEFINITIONS

- A. Adapter Ring: A prefabricated ring that is mounted on the first casing of the pipe string. The purpose is to transfer the effective jacking load between the microtunnel boring machine (MTBM) and the casing.
- B. Annular Space (Annulus): The theoretical volume created by the radial distance between the largest outside radius allowed in the tolerance of the jacking pipe and the extent of the native material excavated by the MTBM shield. Also see overcut.
- C. Backstop: see thrust block.
- D. Break In: The entry point through the shaft sidewall where the MTBM exits the launching shaft/pit and enters into the native material.
- E. Break Out: The exit point through the shaft sidewall where the MTBM exits the native material and enters the receiving shaft/pit.
- F. Carrier Pipe: A pipe placed inside the steel casing for conveyance of effluent sewage.
- G. Casing: A jacking pipe made of steel, which supports a bore external earth and groundwater. The casing is not a carrier pipe. The carrier pipe is constructed within the casing.
- H. Contact Grouting: Injecting grouting outside of the casing/jacking pipe immediately and continuously after the finish of tunnel excavation to fill the annular space and voids with cementations material to create intimate contact for load transfer between the jacking pipe and the native host material.
- I. Controls: Part of the microtunneling system that allows synchronized excavation, removal of excavated material, and jacking of pipe to balance forward movement with excavation so that ground settlement and heave are managed and minimized.
- J. Cutter head: Any rotating tool or system of tools on a common support that excavates materials at the face of a bore.
- K. Drive: Designation of the jacking pipe installed from a jacking shaft to a reception shaft.

- L. Entrance/Launch Seal: A mechanical seal usually comprised of a rubber flange that is mounted to the wall of the jacking shaft. The flange seal is distended by the MTBM as it passes through, creating a seal to prevent slurry, lubrication, soil, and grout inflow into the shaft during tunneling operations.
- M. Exit Seal: Same as launch seal except for the retrieval of the machine at the reception shaft. Used to prevent fluid infiltration into shafts and to prevent ground loss.
- N. Exit Shaft: See Reception Shaft.
- O. Emergency Recovery Shaft: A vertical or sub-vertical excavation required to access the face/cutter head of the MTBM for the purpose of the locating, accessing, repairing the MTBM or for the removal of an obstruction or several obstructions. The use and location is determined by construction necessity and will typically not permit civil structures.
- P. Face: The location where excavation is taking place.
- Q. Face Pressure: Earth and groundwater pressures applied against the cross sectional area of the microtunnel face.
- R. Factor of Safety: A ratio between the structural capacity of a system divided by expected loads or actual loads.
- S. Frac-out: See Inadvertent Returns.
- T. Guidance System: The surveying system that locates the true or actual position of the MTBM. The system locates the MTBM to determine any variation from the designed alignment.
- U. Ground Improvement: Modification or alteration of the strength, behavior, and/or permeability of native or fill materials that are in-situ to improve excavation. The primary use for ground improvement is to facilitate the launch and reception of the MTBM for the launching and receiving shafts. It can also be used to strengthen native ground in the influence zone of the thrust block.
- V. Grouting: The process of filling voids or modifying/improving ground conditions. Grouting materials may be cementitious, chemical, or other mixtures. In microtunneling, grouting may be used for filling the annulus around the jacking pipe, voids outside the jacking pipe or shaft or for improving ground conditions.
- W. Guidance System: System that locates the actual position of the MTBM relative to the design location.
- X. Heave: Measurable upward movement of the ground or structure excavation as the result of the process.
- Y. Inadvertent Returns: The loss of drilling fluid, including slurry and lubrication, from the slurry or lubrication system. A specific form of inadvertent return, where the fluid

exceeds the strength and confining pressure of the ground and reaches the surface or waterway, is called a “hydrofracture” or “frac-out.”

- Z. Jacking Force: The total force required to overcome the face pressure component and frictional resistance component along the pipe string to allow the forward movement of the MTBM and trailing pipe string.
- AA. Jacking Frame: A structural component that houses the hydraulic cylinders used to propel the microtunneling machine and pipeline in the ground. The jacking frame cradles the MTBM and jacking pipes and serves to distribute the thrust load to the pipeline and the reaction load to the shaft wall or thrust block.
- BB. Jacking Loads: See Jacking Force.
- CC. Jacking Pipe: Pipe specifically designed to be installed using pipe jacking techniques. The pipe is engineered to be thrust or jacked through the ground lead by the MTBM. The jacking pipe can serve as the casing or the carrier pipe.
- DD. Jacking/Launch/Entry Shaft: Excavation from which trenchless technology equipment is launched for the installation of a pipeline. The jacking/launch shaft incorporates a thrust wall to spread reaction loads to the ground and an entry ring seal to control inflows of groundwater and ground at the portal.
- EE. Laser: A device commonly incorporated into the guidance system used to track alignment and grade during the tunneling or jacking operation.
- FF. Limits of Excavation: The volume within which excavation takes place.
- GG. Lubrication (Lubricant): The act of injecting a fluid, normally water mixed bentonite and/or polymers, along with other additives, used to reduce the skin friction and jacking forces on the jacking pipe during installation. The fluid fills the annular space and is used to modify the soil properties for ease of excavation.
- HH. Maximum Allowable Jacking Force: The largest jacking force that can be applied to the jacked pipe, allowing for an appropriate factor of safety.
- II. Maximum Anticipated Jacking Force: The largest anticipated jacking force required to advance jacking pipe and MTBM along a drive.
- JJ. Microtunneling: A continuous trenchless installation of the casing pipe by jacking the pipe behind a remotely controlled, steerable, guided, full-face pressure controlled, articulated, microtunnel boring machine (MTBM).
- KK. Microtunnel Boring Machine (MTBM): The microtunneling boring machine refers to the remote controlled, steerable, microtunnel shield jacked through the earth, which excavates the ground in advance of the jacking pipe being installed. Routine entry of personnel entry is not required for operation of the MTBM.
- LL. Obstacle: A foreseen object that has been located near or within the planned

- excavation path or influence of the MTBM and is to be avoided or removed during excavation.
- MM. Obstruction: Any buried object that lies completely or partially within the cross-section of the microtunnel and prevents continued forward progress along the design path and allowable tolerances after diligent efforts by the Contractor. Any object including the shoring / support system and/or the ground improvement shall not be considered an obstruction.
- NN. Overcut: The radial distance between the excavated perimeter of the outermost gauge cutter and the outside radius of the MTBM shield. Also see annular space.
- OO. Penetration Rate: Instantaneous excavation distance per time while the MTBM is operating, typically measured in inches/min or mm/min.
- PP. Pipe Jacking: A system of directly installing jacking pipes behind a shield machine or Tunnel Boring Machine by hydraulic jacking from a jacking shaft such that the joined pipe segments form a continuous string in the ground.
- QQ. Pipe Lubricant: See Lubrication.
- RR. Pipe String: The succession of joined individual jacking pipe segments being used to advance and support the excavation.
- SS. Pitch: The upward or downward angle of the MTBM measured from a theoretical horizontal plane passing through the longitudinal axis of the MTBM. In some MTBMs the pitch may be set to where the design grade is zero in place of the horizontal plane.
- TT. Pre-Treated Ground: Grouted or otherwise stabilized ground used to prevent ground deformation or inflows, or to stabilize existing features.
- UU. Product Pipe: See Carrier Pipe.
- VV. Reception/Exit Shaft: Excavation into which the microtunneling equipment is driven and recovered.
- WW. Roll: The angle of rotation about the theoretical longitudinal centerline of the MTBM measured from the 12 o'clock position.
- XX. Settlement: Measurable downward movement of the ground, overlying utility or other structure as the result of the excavation process or dewatering.
- YY. Shaft Penetration (Penetration): The penetration upon the exiting shaft begins with the MTBM engaged in the wall seal and ends when the machine is buried in the ground and the first casing segment is engaged in the wall seal. The penetration upon entering the shaft begins when the machine breaks through the improved ground prior to engaging the wall seal and ends when the steel casing is fully engaged in the wall seal.
- ZZ. Slurry: A bentonite-water or polymer-water based engineered fluid that is used to

balance the in-situ hydrostatic pressure, transport the excavated solids to the surface via slurry lines, alter the soil behavior, and / or improve efficiency within the slurry system. Engineering properties normally include density, gel strength, liquid limit, pH, sand content, stability, and viscosity. Properties are normally modified by altering proportions of bentonite and adding or altering various polymers, water and additives.

- AAA. Slurry Chamber: A chamber, which is partially filled with slurry is used to combine the excavated soil in the chamber and is pumped to the surface via slurry line(s). The chamber is located behind the MTBM cutter head.
- BBB. Slurry Line(s): A series of hoses or pipes used to transport slurry and slurry containing spoils from the face to the surface. The spoils are separated from the slurry and returned to the cutter head / face of the MTBM.
- CCC. Slurry Pressure Balance Machine: A microtunneling system which uses a pressurized fluid to balance the ground water pressure at the face of the tunnel and to transport the excavated material to the surface.
- DDD. Slurry Separation: A process where excavated material is separated from the circulated slurry. Mechanical separation is typical, although gravity separation in pits or tanks is possible with coarse-grained soils.
- EEE. Slurry Specialist: A professional possessing a specialized education, training and experience with microtunnel slurries meeting the qualified experienced specified herein to design slurry mixes for the variable ground conditions anticipated on this project.
- FFF. Spoil(s): Earth, rock, and other materials excavated during the microtunneling process. Spoils may also be referred to as muck.
- GGG. Sump Pump: A pump used in a remove the incidental groundwater during the construction process. Typically placed in lowest elevation of a shallow excavation and backfilled with gravel to remove groundwater for shaft leakage or seal leakage, remove rainwater and prevent flooding of the tunneling and auxiliary equipment.
- HHH. Thrust Block: An engineered structure located between the jacking frame and the shaft wall which distributes the jacking force developed by the hydraulic jacking frame over a large surface area to the ground behind the shaft back wall. Also known as a thrust reaction structure or backstop.
- III. Thrust Reaction Structure: See thrust block.
- JJJ. Thrust Ring: A fabricated ring that is mounted on the face of the jacking frame. It is intended to transfer the jacking force from the jacking frame to the thrust-bearing area of the jacking pipe segment being jacked.
- KKK. Tooling (Tools): Ground engaging elements of the cutter head designed to excavate and penetrate the ground.

LLL. Zone of Influence: Volume of ground that could possibly be impacted by settlement or heave from either the tunnel mining, shaft excavation, pile driving, or other construction activities.

MMM. Water Jetting: Cleansing mechanism in the cutter head of the MTBM, which utilizes high pressure water to remove cohesive soils in front of the cutter head. To be effective the hydraulic pressure must overcome the in-situ groundwater pressures.

1.2 QUALITY ASSURANCE

A. Requirements outlined below shall be met at the time of bid and remain in force through completion of the project. Subcontracted work does not qualify as experience.

1. The Contractor performing the microtunneling work shall have at least six (6) years of experience in performing slurry microtunneling work and shall have successfully completed:
 - a. Three (3) microtunneling projects installing jacking pipe with an outside diameter (OD) of 60 inches or greater.
 - b. Three (3) microtunneling projects using the same type of jacking pipe material as specified for this project.
 - c. Two (2) microtunneling projects in similar ground conditions as measured by soil type, blowcount (N) value and hydrostatic head, as anticipated on this project, with a drive length of at least 240 feet on each project using an MTBM meeting the requirements of this project.
2. Microtunneling Project Superintendent shall have:
 - a. A minimum of five (5) years of experience in the installation of pipelines using slurry microtunneling methods.
 - b. A minimum of three (3) projects, with each project consisting of at least 250 feet of pipe installed using slurry microtunneling methods.
 - c. Successfully completed two (2) slurry microtunneling projects installing jacking pipe with an OD of 60 inches or larger.
 - d. Successfully completed two (2) slurry microtunneling projects using the same type of jacking pipe material as specified for this project.
 - e. Successfully completed two (2) slurry microtunneling projects in similar ground conditions as measured by soil type, N value, and hydrostatic head, as anticipated on this project.
3. MTBM Operator shall have:
 - a. A minimum of five (5) years of experience in the installation of pipelines

- using slurry microtunneling methods.
- b. A minimum of three (3) projects, with each project consisting of at least 250 feet of pipe installed using slurry microtunneling methods.
 - c. Successfully completed two (2) slurry microtunneling projects installing jacking pipe with an OD of 60 inches or greater.
 - d. Successfully completed two (2) slurry microtunneling projects installing the same type of jacking pipe material as specified for this project.
 - e. Successfully completed two (2) slurry microtunneling projects in similar ground conditions as measured by soil type, N-value, and hydrostatic head, as anticipated on this project using an MTBM meeting the requirements of this project.
4. Calculations for work associated with microtunneling shall be made by a Professional Engineer registered in the State of Colorado. Experience shall include microtunneling design calculations on five (5) microtunneling projects within the last five (5) years.
5. Slurry and lubrication plant specialist shall have:
- a. A minimum of five (5) years of experience in the design of slurry and lubrication mixes based upon anticipated ground conditions and modifications based upon field conditions.
 - b. A minimum of five (5) projects, with each project consisting of at least 250 feet of pipe installed using slurry microtunneling methods.
 - c. Successfully completed two (2) slurry microtunneling projects installing jacking pipe with an OD of 60 inches or greater.
 - d. Successfully completed two (2) slurry microtunneling projects in similar ground conditions as measured by soil type, N-value, and hydrostatic head, as anticipated on this project.
 - e. Performed slurry testing on both feed and return slurry as specified herein.
 - f. Performed lubrication testing as specified herein.
6. Surveyor shall be a Professional Land Surveyor registered in the State of Colorado with experience in underground surveying. Experience shall include:
- a. Three (3) tunnel projects within the last eight (8) years.
 - b. Transfer of points and line from the surface to below ground.
 - c. Closed loop tunnel survey for line and grade.

- d. The use of geodetic surveying if the guidance system requires such.
 7. Experience records shall list the five (5) most recent microtunneling projects, including all microtunneling projects completed for the City, and all projects demonstrating the specified experience. The experience record shall include name of project; owner of the project; names of contacts including all contact information; jacking pipe material used; jacking pipe outside diameter; ground conditions as measured by soil type, N value, and hydrostatic head; longest drive planned and completed; and total footage planned and completed.
 8. The Engineer will be the sole judge in determining if the prospective microtunneling contractor, project superintendent, MTBM operator, microtunnel design calculation professional engineer, slurry and lubrication plant specialist, and surveyor meet the aforementioned work and project experience requirements.
 9. The Contractor's proposed superintendent, the MTBM operator, and the slurry and lubrication plan specialist shall not be permitted to be replaced with personnel with lesser qualifications and without the written approval of the Engineer.
- B. Any jacking pipe that has a special manufacturing property, e.g. pipe stiffness or Maximum Allowable Jacking Force, shall have a different colored stripe; red, blue, or green marking for each non-standard property on the inside and outside, such that the pipe can be readily identified on the surface or when placed in the ground. Standard properties shall be for the most prevalent pipe ordered as measured by pipe inside diameter (ID).
- C. Pipe Lay Schedule shall include:
1. Each pipe on every drive is to be marked with consecutive numbers inside and outside as it is placed for jacking beginning with number 1. All numbers are to be underlined.
 2. Markings shall be acceptable to the Engineer.

1.3 CONTRACTOR SUBMITTALS

- A. Submittals shall be made in accordance with the General Conditions and as specified herein.
- B. Tunneling and related activities, including excavation of shafts, shall not commence until all submittals related to tunneling work have been reviewed and accepted.
- C. Microtunneling submittals specified herein shall be coordinated with all relevant submittals, assembled and submitted as a single, comprehensive submittal. Relevant submittals required for this comprehensive submittal include the required information in Section 02200, Section 02315, Section 02350, Section 02356, Section 02445,

Section 02621, Section 02715, Section 03355, Section 03360, and Section 03610. Contractor shall organize the microtunnel comprehensive submittal package with a table of contents and section dividers.

- D. Where calculations are required to be submitted, they shall be signed and sealed by a Professional Civil Engineer registered in the State of Colorado that satisfies the specified qualification requirement. Calculations shall clearly identify all parameters used, state all assumptions made in the calculation, and identify all sources of information.
- E. All shop drawings shall be legible with dimensions accurately shown and clearly marked in English.
- F. Pre-Construction Submittals:
 - 1. Submit complete information on Contractor's health and safety plan for personnel conducting microtunneling operations. The plan shall include provisions for lighting, ventilation, electrical safe-guards, and rescue.
 - 2. Submit a schedule for all microtunneling operations and associated works including proposed pipe jacking/tunneling cycle, work shifts, scheduled shutdown times and durations for maintenance etc. Schedule shall be coordinated with overall schedule for the Contract, and submittals must be in accordance with any City or CDOT requirements.
 - 3. The following information must be submitted to and approved by the City and CDOT:
 - a. Detailed pipe calculations, confirming ability of product pipe to withstand installation loads and long term operational loads, including water.
 - b. Proposed composition of drilling fluid (based on soil analysis) viscosity and density.
 - c. Drilling fluid pumping capacity, pressures, and flow rates proposed.
 - d. Type of tracking method/system for the drilling application.
 - e. Any other requirements of CDOT to secure an encroachment permit.
 - 4. Submit qualifications and experience records for the following:
 - a. Microtunneling contractor performing the work
 - b. Microtunneling project superintendent.
 - c. MTBM operator.
 - d. Slurry and lubrication plant specialist.
 - e. Contractor's microtunneling engineer.
 - f. Contractor's surveyor.
 - 5. MTBM data sheets and specifications, or a letter from the MTBM manufacturer, demonstrating that the selected machine is capable of progressing through the anticipated ground conditions, including, but not limited to: soil types, soil strength as measured by "N" values, and hydrostatic head.

6. Shop drawings of MTBM, including configuration of cutter head, overcut tolerances, and shield dimensions. Provide details of casing pipe to MTBM interface.
7. Layout and dimensions of jacking and receiving shaft sites showing all major equipment including jacking frame, control console, slurry separation system, spoil removal system, electrical equipment, pipe storage, pipe lifting crane, fencing, construction traffic lanes, etc.
8. Means and routes of MTBM transport to site; method for MTBM assembly on site; dismantling/removal from shafts/site; means and routes of MTBM transport away from site.
9. Calculations confirming planned face operating pressure accounting for operating tolerance, factor of safety, anticipated groundwater level and geotechnical conditions. Include determination of maximum face pressure to prevent frac-outs and heave, and minimum face pressure to prevent over-excavation. Provide the proposed operating face pressures in psi for each drive at every 50 feet in stationing. Corrections related to line losses shall be provided. Include a detailed description of where the MTBM operator will monitor and compare the actual face pressures against the proposed operating face pressures. Detail where the actual face pressures versus proposed face pressures will be recorded in both electronic and manual jacking logs.
10. Grade and alignment control system details including operating parameters and monitoring requirements:
 - a. Provide written confirmation from manufacturer that proposed guidance system can achieve the required line and grade tolerances for the given drive lengths.
 - b. Provide method to protect guidance system from physical disturbances.
 - c. Provide method to mitigate guidance system distortion by heat and/or humidity.
11. Description of main jacking system with details, including jacking capacity, maximum instantaneous jacking speed, and operational requirements.
12. Calculations which clearly state the relationship between hydraulic jacking pressure and jacking force for the main jacks. Provide the method of control to prevent the Maximum Allowable Jacking Force from being exceeded.
13. Calculation of Maximum Anticipated Jacking Force. Identify source of equation, source of friction factor and the factor of safety. Equation and factors shall be from a widely accepted industry source acceptable to the Engineer.
14. MTBM Operating Work Plan:
 - a. Complete launch procedure commencing with any modification to the designed shaft shoring system and ending with the later of the first pipe casing segment jacked into the ground or the MTBM face at least five (5)

- feet beyond the treated entry zone.
 - b. Complete retrieval procedure commencing with any modification to the designed shaft shoring system and ending with first jacking pipe penetrating into the receiving shaft.
 - c. Method statement for providing and utilizing mechanical entry and exit seals. Provide method for confirming stable ground conditions upon cutting the shaft excavation support at entry and exit openings.
 - d. Detailed method of face support and control of excavation at transitions between the treated entry zone and native ground.
 - e. Method statement for preventing the inflow of fluids and soil when removing the mechanical seals.
15. Details of slurry system and spoil separation systems and methods, including proposed slurry formulations by soil type:
- a. Spoil separation plant capacity calculation for slurry volume and solids tonnage.
 - b. Identify pressure gauge and volumetric gauge locations.
 - c. Submit additives to be used for slurry.
 - d. Information regarding slurry mixture, including type, time, volume or weight, of additives used; and how quality control measurements will be taken of mud weights, specific gravity and viscosity. Submit sample log.
 - e. Operational and slurry formulation requirements.
 - f. Operational method(s) of spoil removal.
 - g. General description of spoil disposal including, but not limited to, location, quantity and approval for disposal from the property owner.
16. Pipe lubrication system details including capacity, operating parameters and procedures:
- a. Description of lubrication mixing equipment and procedure for lubricating the pipe during jacking operations, including estimated volume for the anticipated ground conditions.
 - b. Proposed design mix including proportions, water quality, and pH.
 - c. Identify pressure gauge and volumetric gauge locations.
 - d. Identify where lubrication is injected during tunneling.
 - e. Submit sample lubrication log sheet acceptable to the Engineer.
17. Jacking Pipe:
- a. Calculation of Maximum Allowable Jacking Force. Include the hydraulic pressure that is required to develop the Maximum Allowable Jacking Force. Clearly state the factor of safety.
 - b. For 36-inch OD pipe and larger, provide the lubrication and grout port(s) sizing and location.
 - c. Manufacturer's requirements for pipe handling.
 - d. Manufacturer written recommendations for repairs of joint failures and jacking pipe sidewall failure based upon structural failure and non-structural requirements.
18. Shaft design calculations and maximum jacking capacity of the thrust block and shaft wall in compliance with Section 02621.

19. Procedure to accurately and reliably measure the volume of excavated material per pipe segment. Include a determination of the theoretical volume of excavated material per pipe segment and allowable tolerances on this volume. Clearly state any bulking factor used. The actual excavated volume shall be determined after each pipe is installed and prior to commencing the advance for the next pipe and shall be compared with the theoretical volume. Excavated volumes shall also be calculated for partially installed pipes at the end of a shift or during periods of downtime, and at any other times required by the Engineer. A Contingency Plan shall describe measures to be taken by the Contractor in the event that the actual excavated volume exceeds the theoretical volume with tolerances.
20. Provide a sample of operator's daily jacking report and manual jacking log acceptable to the Engineer, in accordance with the requirements specified herein.
21. Provide a sample of the automated record, in English, with information available for recording, variations in data acquisition frequency, and available formats for the Engineer to select automated recording fields.
22. Shaft and pipe ventilation system details including fan size and operating parameters.
23. Electrical system, lighting system, and onsite power generation details.
24. Water sources, handling and disposal.
25. Provide Contingency Plans addressing, at a minimum, the following:
 - a. Excessive ground movement is observed. Provide a plan that includes means and methods of expeditiously restoring any excessive ground movement. Plan must be coordinated with the requirements of Section 02445. Address the means and methods of expeditiously restoring any excessive ground movement or other situation that may impact the operation of major roadways, in particular I-70.
 - b. Spoils do not separate with the equipment on site. Provide a spoil separation plan with testing requirements and operating parameters that are observed and monitored that indicate the spoil separation plant is not performing as intended. Include changes to the separation plant and/or slurry additives.
 - c. Obstruction removal plan with observational and operational characteristics that indicate the MTBM is not advancing because of an obstruction. The removal plan shall include the confirmation of the obstruction including shaft sinking, groundwater control, tunneling, and water-tight tunnel initial support methods. The removal plan shall take into account overlaying structures, topography, and logistical access along the entire microtunnel alignment.
 - d. Guidance problems are noted. Provide a guidance plan with guidance system operational parameters observed, measured, and recorded to

- determine if the guidance system has moved or if heat/humidity distortion is affecting the guidance. Include plan for remediation.
- e. MTBM is off line or grade. Provide a line and grade control plan with operational parameters observed, measured, and recorded to determine if the MTBM is off line and/or grade. Include a plan for remediation.
 - f. Jacking forces exceed design capacity of the pipe, jacking frame, or thrust block. Provide a jacking plan with operational parameters observed, measured, and recorded to determine if the jacking force is increasing at a rate that would exceed the Maximum Allowable Jacking Force or the jacking force is increasing at a rate causing reasonable concern for completing the drive. Include a plan for remediation.
 - g. Inadvertent returns observed. Provide an inadvertent return plan with cleanup methods; emergency telephone numbers; sources of equipment and materials needed for containment and clean-up; and corrective actions for reducing operating pressures and modifying the slurry and/or lubricant. Slurry and lubrication inadvertent return plan shall include operating parameters that are controlled with the intent of preventing an inadvertent return.
 - h. Failure of jacking pipe. Provide a jacking pipe failure plan with inspection, repair, and removal plans. Repair methods shall be acceptable to the pipe manufacturer and the Engineer.
 - i. Provide an operational plan to prevent sudden ground loss if the MTBM suddenly encounters flowing non-cohesive soils that exhibit flowing conditions and negligible stand-up time. Provide an operational plan with operational parameters observed, measured, and recorded to determine that non-cohesive soils are encountered. The plan shall include slurry modification, and other operational modifications deemed important and acceptable to the Engineer.
 - j. Excavated volumes exceed tolerance of theoretical volume. Provide a plan to proactively determine when excavated ground volume exceeds tolerances on theoretical volume. Provide a remediation plan.
 - k. Noticeable hydrocarbon smell is detected in the MTBM, tunnel or shaft.
 - l. Thrust block deforms excessively under jacking loads, shows signs of structural damage, or provides insufficient capacity to advance pipe.

G. Construction Submittals:

1. Notifications:
 - a. All notifications are to be provided in writing and within one working day unless otherwise specified herein.
 - b. Immediately notify the Engineer when the MTBM is off line or grade by 50 percent of the maximum allowed. Include written description of the operational changes being made to avoid attaining the maximum allowed.
 - c. Immediately notify the Engineer when the MTBM is off line or grade by 80 percent of the maximum allowed. Include written description of the operational changes being made to avoid attaining the maximum allowed.
 - d. Immediately stop tunneling and notify the Engineer when the MTBM is off line or grade by 100 percent of the maximum allowed. Include written description of the operational changes being made and acceptable to the

- Engineer before the resumption of tunneling.
- e. Immediately notify the Engineer in writing upon encountering an object that impedes the forward movement of the MTBM.
 - f. Immediately notify the Engineer upon implementation of any contingency plan.
2. Records of the start-up inspection shall be submitted to the Engineer within 24-hours of the completed inspection and prior to tunneling. The requirements of the start-up inspection are included herein.
 3. A site acceptance certification shall be submitted to the Engineer within 24-hours of the completed inspection and prior to tunneling. The requirements of the site acceptance certification are included herein.
 4. Records of the survey and verification of correct alignment for the jacking frame and guide rails shall be submitted to the Engineering within 24-hours of the completed survey and prior to tunneling. The requirements of this survey are included herein.
 5. The Contractor shall maintain a daily microtunneling shift log for the entire drive. A copy of the shift logs shall be submitted to the Engineer at the end of each shift. The jacking shift log shall be based primarily on data recorded by the MTBM control system and annotated by hand notes by the MTBM operator, as appropriate. A hard copy of the jacking shift log, updated at the end of each shift, shall be kept at the MTBM control console and shall be available to the Engineer for review at any time. Manual jacking reports shall include three recording points of measurements for each pipe segment. Provide information for the first recording point within one foot of the start, second recording point near the midpoint, and third recording point within one foot of the end. For pipe segments longer than 10 feet, add one recording point at the midpoint between the first and second recording points and add one recording point at the midpoint between the second and third recording points for a total of five recording points. As a minimum, the jacking shift log shall contain the following information, with the units of measure, for each pipe section jacked:
 - a. Project name.
 - b. Tunnel drive identification.
 - c. Start and finish times for each crew.
 - d. Start and end time for each pipe segment.
 - e. Location of pipe by station at the start and end of shift.
 - f. Number of each pipe segment installed and length of pipe.
 - g. Printed name of operator and signature.
 - h. Time of measurement.
 - i. Station of cutter head face at the time of measurement.
 - j. Position of the MTBM in relation to design line and grade.
 - k. Position of steering jacks.
 - l. Maximum jacking force exerted by the main jacks.
 - m. Advance rate.
 - n. Inclination and roll of the cutter head.
 - o. Movement of the guidance system.

- p. Torque on cutter head.
 - q. Cutter head rotation-per-minute (RPM).
 - r. Slurry flow rates and pressures, face pressures, cutting chamber pressures, bypass valve position, use of any high-pressure nozzles.
 - s. Difference between theoretical face pressure calculated in the approved comprehensive microtunneling submittal.
 - t. Information regarding slurry mixture, including type, time, volume or weight, of additives used; measurements of mud weights, specific gravity and viscosity.
 - u. Location of significant loses of slurry, if any; the amount of slurry or water added to the slurry separation unit; volume of spoil and slurry removed from the jacking shaft site
 - v. Volume of excavated material versus theoretical volume for each pipe segment.
 - w. Setting and resetting of MTBM's pitch.
 - x. Setting, resetting system and verification of the laser's slope or guidance system.
 - y. Resetting or adjusting the laser and the affect to line and grade.
 - z. Observations of settlement and heave.
 - aa. Any problems encountered since last recording point.
 - bb. Information regarding pipe lubricant, including volume placed and locations of injection, lubricant mix design and pumping pressures.
 - cc. Any unusual conditions or events encountered with the MTBM operation; reasons and durations for shutdowns and delays.
 - dd. Tunnel construction water control operations; pumping and discharge records.
6. The automated data recording system shall record the same operating parameters as specified for manual recording, unless otherwise specified by the Engineer. Electronically recorded data shall be referenced to time and cutter head location and shall be recorded at time intervals of one (1) minute or less. Electronic records shall be in a database file with clear labeling for each metric recorded along with the corresponding unit of measure.
7. Provide contemporaneous log of all manual line and grade checks including MTBM instrument and guidance system resets and adjustments. Submit readings to the Engineer on the same work day the readings are taken. Log shall be independent of the jacking reports and include:
- a. Date, time, pipe number, and person making adjustment.
 - b. Measurements immediately before adjustment.
 - c. Measurements immediately after adjustment.
 - d. Survey data if adjustment is performed based upon survey data.
 - e. Daily verification of design slope and person making verification.
 - f. Date, time, pipe number, and person resetting line and grade control.
 - g. Provide interpretation of survey results to the Engineer.
 - h. Provide contemporaneous written log of all laser set-ups and adjustments.
 - i. Provide copies of field forms used to establish all lines and grades.
8. A slurry log sheet shall be recorded by the Contractor. The slurry log shall

include one recording point of measurements for each pipe segment. If one hour passes where no forward progress is made with the MTBM, an additional recording point of measurements is to be made before tunneling resumes. The slurry log must include: date, shift, operator, number of batches mixed, additives used and quantities, mix properties including pH, specific gravity, viscosity and mud weight.

9. A lubrication log sheet shall be recorded by the Contractor. The lubrication log must include: date, shift, operator, number of batches mixed, composition, mix properties including pH, density, viscosity and gel strength. Also include pipe number, injected quantity and injection pressure per pipe.
10. Provide water jetting reports and include by pipe number and time the maximum pressure and total water volume.
11. Provide all manual and automated records and logs by 9 AM the following work day. Provide hard copy and electronic copy of automated records in formats acceptable to the Engineer.

H. Post-Construction Submittals:

1. Provide as-built survey of the casing pipe starting with the first survey point taken within six inches of the downstream shaft pipe string end, continuing with one point taken within three inches of the upstream side of at each joint, and ending with a point taken within six inches of the upstream shaft pipe string end. Provide results in both tabular format and AutoCAD format acceptable to the Engineer. Scale to be acceptable to the Engineer. Survey shall confirm that carrier pipe can be installed within design tolerances.

1.4 PROJECT CONDITIONS

- A. For geotechnical information refer to “Geological Hazards and Geotechnical Investigation Persigo Wastewater Treatment Plant Outfall Grand Junction, Colorado, Project # 01543-0001 dated October 10, 2017.
- B. Site specific data:
 1. Test Pit TP-1 as reported in the Geological Hazards and Geotechnical Investigation Persigo Wastewater Treatment Plant Outfall was dug in September of 2017 to a depth of 13 feet in the center median of I-70. Material in TP-1 was Gravelly Clay with Cobbles to Clayey Sand with Gravel for the first 5 feet with Sandy Gravel and Cobbles below 5 feet. Cobble sizes of up to 12 inches were observed. The material exhibited characteristics of flowing, non-cohesive, non-plastic soils in accordance with the Tunnelmans Ground Classification. Groundwater was observed at a depth of 9 feet. Surface elevation is approximately 4514 above mean sea level.
 2. Test Pit TP-2 as reported in the Geological Hazards and Geotechnical Investigation Persigo Wastewater Treatment Plant Outfall was dug in September of 2017 to a depth of 10 feet approximately 20 feet north of westbound of I-70 at a location approximately equal to the receiving shaft. Material in TP-2 was Clayey Sand with organics for the first 2 feet where it

transitioned to Clayey Sand with gravel to a depth of 7 feet. Below that elevation was observed to be Sandy Gravel and Cobbles. Cobble sizes of up to 12 inches were observed. The material exhibited characteristics of flowing, non-cohesive, non-plastic soils in accordance with the Tunnelmans Ground Classification. Groundwater was observed at a depth of 8 feet. Surface elevation is approximately 4514 above mean sea level.

- C. For baseline purposes, the anticipated ground conditions along the trenchless alignment indicated on the Contract Drawings are baselined as the following.
 - 1. Soils at the proposed horizon of the trenchless alignment will consist of flowing to running ground, non-cohesive sandy gravel and cobbles (GP)
 - 2. Full face of non-cohesive materials that will fast ravel and flow when not adequately supported at the face.
 - 3. Granular materials will be encountered during the launching, receiving and tunnel excavation. Direct communication with the Colorado River and nearby tributaries will exhibit flowing behavior when not adequately supported or dewatered.
 - 4. The relative percentage of non-cohesive materials such a sand, gravel and cobbles will be more than 95% within the tunnel zone.
 - 5. Cobbles, as defined ASTM D2487 – USCS, are the coarsest material to be encountered during excavation along the alignment shown on the Contract Drawings. Nested cobbles are expected along the tunnel alignment.
 - 6. Non-cohesive materials will cause excessive abrasion and wear to the tooling used for excavation.
 - 7. Approximately 5% or less fines are to be encountered along the within the tunnel zone.
 - 8. The upper five (5.0) feet of ground cover shall be assumed to be artificial fill material. Asphalt and aggregate are anticipated under the Interstate 70. A maximum of 30% of the bank volume of the excavated fill material will contain cobble-sized material.
 - 9. As stated in the Geotechnical Exploration Report, groundwater level varies along this alignment. The groundwater is influenced by the water surface in the Colorado River and may be higher or lower during construction.
 - 10. For design purposes, groundwater levels will be at Elevation 4510 feet prior to be dewatering to allow for potential raised elevations.
- D. Engineered fill of unknown character, material, and engineering properties, may be present beneath the I-70 embankment to an unknown depth. For design purposes, soils at launch and reception shaft and within the proposed trenchless horizon, will be native. The optional intermediate shaft will contain approximately 5 to 8 feet of artificial fill.
- E. Utility information is shown on the Contract Drawings.

- F. The Contractor shall comply with all restriction set as conditions under which the easements and permits are granted to perform this project.
- G. The Contractor shall inspect all work sites to become familiar with the work conditions and with all necessary details as to the orderly execution of this project. The omission of any details, which may not appear herein, shall not relieve the Contractor of his full responsibility for compliant execution of the project.
- H. Access to Site and Equipment:
 - 1. The Contractor shall allow access to the Engineer and/or Owner and shall provide necessary assistance and cooperation to aid the Engineer and/or Owner in documenting observations, measurements, and sample collection prior to, during and following all pipe jacking operations. Access shall include but not limited to:
 - a. The Engineer and/or Owner shall have full access to the MTBM and jacking system during all site activities to prior to tunneling to make measurements and during tunneling to visually observe jacking forces and steering corrections.
 - b. The Engineer and/or Owner shall have full access to the operator control container prior to, during, and following all microtunneling operations. This shall include providing visual access to real-time operator control screens, gauges, and indicators.
 - c. The Engineer and/or Owner shall have full access to the jacking and reception shafts and installed pipe string to visually inspect installed pipes, shaft seals, and line and grade.
 - d. The Engineer and/or Owner shall have full access to the slurry separation plant to collect samples a minimum of once per installed pipe section or every 10 feet from the shaker screens. This shall include access to shaker screens, hydrocyclones, conveyor belts, centrifuge equipment and slurry and spoil holding tanks.
 - e. The Engineer and/or Owner shall have full access to the bentonite lubrication plant to visually inspect storage and mixing tank levels, lubrication pressures and pumping rates, amount and type of additives, and collection of samples to determine lubrication properties.

2.2 SAFETY

- C. The CONTRACTOR shall train all non-Contractor project staff in entry operations prior to entry.

PART 2 - PRODUCTS

2.1 MTBM AND ANCILLARY EQUIPMENT

- A. The Contractor shall be fully responsible for the design, testing, supply, installation and removal of the microtunneling machine(s) and ancillary equipment.
- B. The MTBM Remote Control System shall meet the following minimum requirements:
 - 1. Allow for routine operation of the system without the need for personnel to enter the tunnel.

2. Display available to the operator, showing the position of the MTBM in relation to a design reference together with other information such as time and date, MTBM roll, pitch, complete guidance system to indicate MTBM position relative to the reference point, steering jack position, valve positions, high-pressure nozzle use, thrust force, cutter head torque, rate of advance, rotation rate, pressure of the slurry and earth pressure balance at the face, slurry flow rates in both the slurry supply and return lines, bypass valve position, and installed length. All data shall be electronically recorded continuously by the control system. Additional information must also be available for completing the required submittals specified herein.
 3. Integrate the system of excavation and removal of spoil and its simultaneous replacement by pipe. As each pipe segment is jacked forward, the control system must synchronize all of the operational functions of the system.
- C. The MTBM and ancillary equipment shall meet the following minimum requirements:
1. The MTBM shall be equipped with a cutter head and accessories capable of cutting, excavating and removing the soils and ground conditions described in section 1.5 of this specification as well as any pre-treated ground. Careful consideration must be made for impacts to the microtunneling operation if the Contractor chooses to leave grouting equipment in the ground. If the Contractor chooses to leave grouting equipment in the ground, the MTBM must be designed to excavate through the equipment without impacts to the microtunneling operation. Provide robust and suitable tools on the cutter head in order to avoid the need for replacement during the drive.
 2. Contractor may adjust the excavated diameter to fit their means and methods, up to a maximum annular space/overcut of 0.50-inch radially, as long as the selected diameter enables the installation of the carrier pipe in accordance with Section 02715, meets the requirements herein, conforms with CDOT requirements, and does not increase the risk of settlement-induced damage.
 3. The MTBM shall be slurry based, pressurized, closed-face, shielded and capable, at all times, of maintaining face stability through continuously monitoring and adjusting face support pressure to balance the soil and groundwater pressures at the face using bentonite slurry. The MTBM shall use an automated slurry system that balances the groundwater pressures with the capability to make the adjustment required to maintain face stability for the particular ground condition encountered and shall monitor and continuously balance the groundwater pressure to prevent loss of slurry or uncontrolled groundwater inflow. Provide pressure adjustment to an accuracy of better than +/- one (1) foot of equivalent hydrostatic head.
 4. A slurry type MTBM shall include a slurry bypass unit in the system to allow the direction of flow to be changed and isolated, as necessary.
 5. The control system shall coordinate rate of excavation and machine advance rate to avoid over-excavation.
 6. The MTBM shall be capable of controlling rotation or roll by means of bi-directional drive on the cutter head or by the use of fins or grippers. The MTBM shall be mechanically articulated to enable steering of the shield in all directions. Provide steering joint designed to expel accumulated material when articulated in a closed direction or protect steering joint from accumulating material.
 7. The MTBM shall be equipped with a roll indicator and laser target system to

permit continuous monitoring, control and setting of line and grade. Line and grade shall be controlled by a guidance system that relates the actual position of the MTBM to a design reference established by a laser beam transmitted from the jacking shaft along the centerline of the pipe to a target mounted on the MTBM, or equivalent system. The steering information shall be monitored and transmitted to the operation console. As a minimum, this information shall include location of the laser beam or other guidance system on the target and location of the cutter head. Provides a reference laser, or other submitted device that indicates visually in the jacking shaft that the directional control laser has not been accidentally moved.

8. The MTBM shall have protected motors and operating controls against the anticipated water inflows. Parts and components shall be water resistant.
 9. The MTBM shall be equipped with a fire warning system.
 10. Hydraulic fluids used in the MTBM shall be fire resistant, in accordance with NFPA 241, and shall be certified by the manufacturer as being fire resistant.
 11. The MTBM shall be equipped for monitoring hazardous gases, with alarms and automatic shut-off.
 12. A means for injecting pipe lubricant at the lead edge of the first pipe section shall be incorporated in the MTBM.
 13. The interface between the tail skin of the MTBM and the lead pipe shall be contained by watertight gaskets and/or seals to prevent materials or water from entering the MTBM or the pipe.
- D. Entrance Seal and Exit Seal:
1. Full perimeter entry and exit seals are required at each eye to contain slurry, annulus lubricant, grout and to minimize the risk of ground running, flowing or raveling into the shaft. The design of the seal must address all possible failure modes including leakage paths between grouted soil and shoring, between mechanical seal and shoring, and between casing and shoring. Shaft eye seals shall prevent inflow of groundwater, annulus lubricant, slurry, and grout.
- E. MTBM Spoil Transport and Separation
1. The MTBM shall include an automated spoil transport system that shall match the excavation rate to the rate of spoil removal thereby maintaining settlement or heave within tolerances specified.
 2. The slurry spoil separation process shall suit the size of the tunnel being constructed, the soil type being excavated, and the available space for erecting the separation plant. The system may employ mechanical shakers, screens, de-silting cones, hydrocyclones, and centrifuges. Slurry separation using only sedimentation tanks will not be permitted. The separation process shall be designed to provide adequate and efficient separation of excavated solids from the slurry such that clean slurry can be returned to the cutting face for re-use and the solids can be removed and disposed of in an efficient manner. Provide a slurry separation plant capable of processing:
 - a. A minimum of 25 percent more slurry than that anticipated by the Contractor's MTBM selection and instantaneous advance rates.
 - b. A minimum of 10 percent more solids than the fastest possible instantaneous advance rate based upon fastest possible hydraulic jack extension rate.
 3. Monitor the composition of the slurry to maintain the slurry weight, gel strength, and viscosity limits defined by the operating parameters.

4. Contain separated spoils for removal from site.
- F. The Contractor shall maintain an inventory recommended by the MTBM and backup systems' manufacturer(s) to ensure continued availability of MTBM and all essential systems. At a minimum, the following inventory of spare parts shall be maintained and be available on site within a maximum of 12 hours:
 1. Power and control cables.
 2. Slurry lines.
 3. Drive motors (excluding MTBM internal motors)
 4. Hydraulic cylinders, hoses, controls, and seals.
 5. Bearings and seals for all motors and pumps.
- G. Use a power generator which is suitably insulated for noise in residential or commercial areas. All construction generated noise and vibration shall not exceed levels contained in Federal, State, and local regulations, standards, codes and ordinances.
- H. Enclose lighting fixtures in watertight enclosures with suitable guards. Provide separate circuits for lighting and other equipment.
- I. Electrical systems shall conform to requirements of National Electrical Code – NFPA70.

2.2 JACKING SYSTEM AND THRUST REACTION STRUCTURE

- A. A main pipe jacking system consisting of hydraulic jacks and a suitable jacking frame shall be provided. The hydraulic cylinder extension rate of the jacking system shall be synchronized with the excavation rate of the MTBM. Provide a jacking system capacity that exceeds the maximum anticipated jacking force by at least 20 percent.
- B. The jacking system shall develop a uniform distribution of jacking forces on the end of the pipes by the use of thrust rings and cushioning material specified herein; and shall have pressure control devices to ensure that the load capacity of the pipes will not be exceeded at all times.
- C. The jacking frame shall be reacted by a thrust reaction structure. The thrust reaction structure shall have a design capacity equal to the maximum anticipated jacking load with a minimum factor of safety of three (3.0).
- D. The thrust reaction structure shall be designed and installed such that it will not overstress any shaft elements and that it will not load any previously installed pipes from the same jacking shaft. Deformations or deflections that could cause misalignment of the jacking frame or damage to existing adjacent utilities shall not be permitted.
- E. Provide pipe clamps, or other means, to hold the jacked pipe in place during the retraction of hydraulic jacking rams and insertion of subsequent pipe segments.

2.3 JACKING PIPE

- A. Refer to requirements of Section 02315 for casing pipe.

2.4 SLURRY AND PIPE LUBRICANT

- A. The Contractor is required to use products with a proven history of performance for microtunneling in the anticipated ground and groundwater conditions, as specified herein. The Contractor shall submit microtunneling slurry and pipe lubricant data sheets to the Engineer for review and approval.
- B. High yield sodium bentonite designed for microtunneling shall be used.
- C. The Contractor shall develop a lubrication mix design based upon the anticipated ground and groundwater conditions.
- D. The Contractor shall develop the slurry mix design to ensure a stable face, allow

control of face pressures, minimize over-excavation, and maintain a filter cake on the exposed ground. The Contractor should anticipate the use of bentonite slurry to achieve these requirements and should address the effects of mining through grouted soil on the slurry and brackish groundwater, and any necessary supplementary additives required to deal with these effects.

- E. Bentonite, polymers, or other additives used for slurry and pipe lubricant shall be non-toxic and shall not adversely affect groundwater quality. Bentonite, polymers, and additives, other than soda ash, shall be NSF/ANSI Standard 060 compliant. Bentonite shall have the capability of mixing with water to form a stable and homogenous suspension.
- F. If the Contractor elects to use products capable of being used in brackish water, then NSF approval is not required and these salt water additives shall not be mixed with NSF approved additives.
- G. Water used for making the slurry and pipe lubricant shall be potable.
- H. Test all water for pH and treat with accepted materials, to adjust the pH of the water as required in the accepted mix design(s).

2.5 CONTACT GROUT

- A. Contact grout shall be as specified in Section 03360.
- B. Contact grout shall be of the Contactor's design and shall be subject to the review and approval of the Engineer.
- C. The Contractor is required to use products with a proven history of performance and shall submit the contact grout mix design as well as any manufacturer data sheets to the Engineer for review and approval.

2.6 CARRIER PIPE PLACEMENT AND BACKFILL GROUT

- A. The carrier pipe shall be as specified in Section 02716. Equipment for placement of carrier pipe is specified in Section 02715.
- B. The annular space between the carrier pipe and casing pipe shall be backfilled with grout as specified in Section 03360.

PART 3 - EXECUTION

3.1 MICROTUNNELING OPERATIONS

- A. General Requirements
 - 1. Perform all work in accordance with accepted submittals.
 - 2. .
 - 3. The Contractor shall not begin any microtunneling operation until all required preconstruction surveys and construction line control points and reference lines have been completed and all applicable submittals have been reviewed and approved, where necessary, by the Engineer.
 - 4. Maintain a copy of the Contract Documents in the MTBM control container or other location acceptable to the Engineer and accessible to the MTBM operator.
 - 5. Dewatering shall not be permitted during microtunneling along the vicinity of the microtunneling alignment or in the vicinity of the launching or receiving shafts during microtunnel operations.
 - 6. Locate all utilities in accordance with the General Conditions before commencing microtunneling excavation. Protect in-place or relocate existing utilities as required. Remove and replace in-kind any damaged utility.
 - 7. No excavation deeper than four (4.0) feet shall be permitted within 100 feet of

- the microtunnel alignment during microtunneling operations, except:
- a. Potholing to locate utilities or other subsurface features;
 - b. Installing instrumentation as specified in Section 02445.
 - c. If a construction need arises for an emergency recovery shaft.
8. Alignment Survey and Checks
- a. The Contractor shall check the baseline and benchmarks at the beginning of the work and submit immediately any changes, errors, or discrepancies.
 - b. Establish control points sufficiently far from the tunnel operation so as not to be affected by ground movement or any other work on the project.
 - c. Check the primary survey control for the tunneling system against an above ground undisturbed benchmark at least once every shift.
 - d. Provide a cumulative line and grade record during construction and locate previous survey points within 2.0 feet of the location previously surveyed.
9. Shaft Related Elements
- e. The microtunneling operation shall not commence until both the jacking shaft and the receiving shaft have been completed, all contingency measures are put in place, and the receiving shaft and exit seal are ready to receive the MTBM.
 - f. Pre-treat ground as specified in Section 03610 and as specified herein. The Contractor shall pre-grout or otherwise improve the soils around tunnel entry and exit openings to stabilize the soils. The ground around these openings shall be improved to the extent that no entry of soil or water into the shaft shall occur while the openings are being created, when the MTBM is being launched or received, or when the MTBM is in use. The Contractor shall submit the method and procedure for sealing and removal of the shaft wall elements at the openings in accordance with submittal requirements set forth in this Specification.
 - g. The thrust block(s) shall be normal to the pipe alignment and shall be designed to support the maximum obtainable jacking loads developed by the proposed main jacking system. Special care shall be taken when setting the jacking frame to ensure correctness of the alignment, grade and stability.
 - h. Pipe jacking operations shall not commence until the concrete thrust block, tremie seal, pre-treated ground zones, where indicated in the Contract Documents along the respective drive, are in place, and pre-treated ground and concrete have attained the minimum required strength as stated in the accepted submittals.
10. Conduct all microtunneling operations in accordance with OSHA safety regulations and Contractor's own project-specific safety plan.
11. The Contractor shall have on site all safety equipment required for personnel.
12. The Contractor shall provide, install, maintain, and operate drainage facilities at the shaft bottom and in the tunnel to collect and dispose of water that enters the excavated tunnel. Provide a sump and pump at the bottom of the shaft, if necessary. The Contractor shall be responsible for obtaining any additional permits required for treatment and disposal of fluids from the shaft and tunneling operation.
- B. Work Area Preparation and Maintenance
1. Organize microtunneling surface equipment for each drive in such a manner as to enable proper operation at all times, to minimize impacts to property owners,

- and to maintain traffic control patterns and pedestrian access as specified.
 2. Provide suitable containment basins made of plastic lining and sand bags for any equipment operating with fuel, hydraulic, or lubrication oils.
 3. Maintain and keep all equipment in working order. All oil, hydraulic, or fuel leaks shall be repaired immediately upon discovery. Any leaking equipment shall not be used until repaired. Any fluid shall be contained and cleaned up upon discovery. Provide written notification within four (4) hours of discovery.
 4. Contain all lubricant and slurry spills upon discovery and clean up and dispose of spills properly. Provide written notification within four (4) hours of discovery.
 5. Protect guidance system from accidental movements, i.e. bumping by personnel or equipment.
 6. Provide temporary drainage facilities during construction.
- C. MTBM and Equipment Start-Up Inspection and Testing
1. A start-up inspection of all mechanical and hydraulic systems and power supply shall be conducted in the presence of the Engineer. All systems shall be tested on the ground surface to ensure the proper functioning of the MTBM and ancillary equipment. The Engineer shall be notified at least 72-hours prior to the start-up inspection. Key system and equipment performance data shall be measured and recorded by the Contractor during this inspection, including cutter head rotational torque, functioning of main and steering jacks, guidance systems.
 2. A site acceptance certification is required from the manufacturer or Contractor Representative (familiar with inspection of microtunnel equipment) that the MTBM has gone through a no-load performance test on the project site and that all electrical, mechanical, and hydraulic systems are functioning properly and that all components of the MTBM have been properly connected. If the MTBM manufacturer no longer provides support of subject equipment, an independent, licensed Professional Engineer who has documented extensive experience in the MTBM industry may conduct the site inspection and provide the site acceptance certification. Documentation of the independent engineer's experience shall be provided.
 3. The equipment manufacturer of the selected slurry separation equipment or Contractor Representative (a licensed Professional Engineer familiar with inspection of microtunnel equipment) shall provide a site acceptance certification that it is appropriate for this application and the anticipated ground conditions.
 4. The location, orientation and grade of the jacking frame or guide rails and entry/exit seals shall be surveyed to ensure they meet the designed line and grade. The jacking frame or guide rails shall be inspected to make sure that they are securely attached to the shaft base slab, with supplementary grout if necessary.
- D. Control of Line and Grade
1. The Contractor shall conduct preconstruction surveys to verify benchmarks and furnish and maintain reference lines for line and grade of the microtunneling alignment.
 2. The MTBM guidance system shall be mounted on objects that are free from any movements at all times during the pipe jacking operation. In particular, the guidance system shall be independent from the jacking frame and the thrust

reaction structure where there is movement during jacking.

3. The Contractor shall verify the guidance system setup for accuracy at least three (3) times per shift, once at the beginning, once at the middle, and once at the end of the shift, or as directed by the Engineer. The Engineer may check the guidance system setup prior to each shift, and prior to beginning of each microtunneling drive.
4. Maintain the following line and grade tolerances at all times:
Line..... ±6 inch
Elevation..... ±6 inch
Horizontal Corrections.....1 inch/25 feet
Vertical Corrections.....1 inch/25 feet
5. No Sags or “bellies” will be allowed in microtunnel. Positive grade shall be maintained from upstream to downstream tunnel segment.
6. The MTBM shall be steered to maintain line and grade within the above tolerances. Any deviations in line and grade of the casing pipe must allow for the carrier pipe to be shifted within the casing pipe to compensate for such deviations to maintain the line and grade indicated on the Contract Drawings. This shall be achieved by continuously monitoring and adjusting line, grade, machine inclination, roll, and steering attitude during operation. Make immediate correction to alignment before allowable tolerances are exceeded

E. Control of Ground

1. The Contractor shall conduct microtunneling operations and all other related construction activities with care to control ground movements at all times and at all locations. Refer to Section 02445 for limits of ground settlement and structural movement and corresponding action plans.
2. The Contractor shall control and maintain face support pressure by using bentonite slurry at all times for all microtunneling drives so that the slurry cake can be formed and earth and hydrostatic pressures will be balanced at all times at the excavation face.
3. Add bentonite, polymers or other additives as necessary to the slurry to maintain the viscosity and gel-strength required to minimize soil erosion or slurry loss at the face when mining through all ground conditions and pre-treated ground.
4. The MTBM shall be operated such that the rate of excavation shall be compatible with the rate of advance. Continuously control and adjust the rate of advance and monitor the volume of material excavated to avoid over-excavation, loss of ground, or surface heave.
5. During shutdown periods, support the face of excavation by positive means; no support shall rely solely on hydraulic pressure. Whenever the jacking operation is suspended or shut down, the Contractor shall maintain qualified personnel on site to observe conditions that may threaten the stability of the heading. Such personnel shall be equipped with an approved contingency plan and the necessary equipment to take appropriate action to prevent or limit damage should conditions occur which threaten the stability of the heading.
6. Inspect MTBM and all pertinent equipment between reaches for wear and damage. Repair/refurbish as necessary between reaches.
7. The Contractor shall be responsible for any damage due to ground movement in excess of the allowable, resulting from any construction activities associated

with the microtunneling operations.

F. Pipe Jacking

1. Control and regulate hydraulic pressure to maintain optimum jacking loads to be compatible with pipe jacking advance rate, and to limit operational jacking loads within the jacking capacity of the pipe and the thrust reaction structure.
2. The Contractor shall continuously inject pressurized lubricant around the leading edge to completely fill and maintain the annular space and lower friction along the pipe surface during jacking. Volumes of lubricant pumped shall be recorded and shall be at least equal to the volume of annular space. Lubrication pressure shall be continuously maintained during active operation periods and during shutdown periods. The maximum lubrication injection pressure shall not exceed the overburden pressure (including hydrostatic pressure) to cause hydrofracturing of the ground. All records relating to the use of pressurized lubricant shall be submitted to the Engineer.
3. Maintain a watertight seal around the tunnel entry and exit openings to counterbalance groundwater pressure, lubricating pressure, grouting pressure, and keep soil from entering the shafts.
4. The Contractor shall notify the Engineer immediately in the event that a section of pipe is damaged during jacking, or a joint failure occurs, as evidenced by inspection, visible groundwater inflow or other observations. The damaged subject shall be repaired in accordance with agreed procedures and the repair or replacement shall be done at the Contractor's expense and shall be to the satisfaction of the Engineer.
5. The Contractor shall provide and use pipe clamps, or other means, to hold the jacked pipe in place at the MTBM entry during the retraction of hydraulic jacking rams and insertion of subsequent pipe sections.

3.2 SLURRY SPOIL SEPARATION AND DISPOSAL

- A. The slurry transport and separation system shall be operated and maintained to avoid schedule delay by providing adequate separation of the spoil from the slurry so that clean slurry can be returned to the cutting face for re-use. Maintenance of all related equipment shall be made in accordance with manufacturer's recommendations or as directed by the Engineer.
- B. If excavated solids cannot be adequately separated from the slurry in order to re-use the slurry, the Contractor shall carry out off-site transportation and disposal of slurry and solids as specified herein and supply additional fresh slurry at no additional cost to the City.
- C. Any slurry spills shall be contained, removed and disposed off-site in accordance with the approved plan. Slurry spills within any open excavations shall be prevented from entering the shaft sump to avoid being pumped and discharged into the disposal system.

3.3 REMOVAL OF OBSTRUCTIONS

- A. The Contractor shall have prepared plans for removal of any obstructions and in accordance with applicable permit requirements.
- B. The Contractor shall endeavor to remove or advance past obstructions using reasonable means subject to the following procedures and criteria:
 1. The Contractor shall notify the Engineer immediately upon encountering an obstruction that stops the forward progress of the MTBM. The Contractor shall

provide the Engineer with details of the nature of the obstruction, and allow the Engineer access to examine all observations made by the Contractor relating to the obstruction.

2. The Contractor shall proceed with removal of the obstruction in accordance with the Contractor's previously approved submittals. In the event of encountering an obstruction under the I-70 right-of-way, the Contractor shall obtain approval from CDOT and the Engineer before execution of removal operations.
3. The Contractor shall perform necessary checks to verify the MTBM is not in any way damaged due to the obstruction before resumption of operation upon completion of the obstruction removal.

3.4 CONTACT GROUTING

- A. Contact grout shall be as specified in Section 03360.
- B. Contact grout is required at the locations of shaft/tunnel interfaces after the completion of tunnel excavation. Inject contact grout, as necessary, to remove shaft seals without the inflow of fluids or loss of soil.
- C. If using an MTBM OD of 54 inches or larger, immediately and continuously after the completion of the drive, the Contractor shall perform contact grouting to fill the annular space along the entire pipe. Grouting must commence within 24 hours of completion of the microtunnel excavation jacking to prevent any surface settlement due to movement of the soil material into the void space around the microtunnel casing. The grout shall be injected under sufficient pressure to replace any lubricant. The grouting system shall be sufficiently sized to handle voids outside the limits of the annular space created by caving or collapsing of earth cover over the tunnel excavation.
- D. The Contractor shall furnish and operate suitable equipment for grouting operations. Grouting pressure shall be controlled so as not to damage the already installed pipe and joints, adjacent utilities, and other properties. The grouting pressure shall also not exceed the overburden pressure (including hydrostatic pressure) to cause hydrofracturing of the ground. The maximum grout pressure for each drive shall be submitted to the Engineer for review and approval.
- E. After completion of the contact grouting, the grout ports shall be plugged and the interior of the pipe finished to a smooth, even surface and watertight condition.

3.5 INSTRUMENTATION AND MONITORING

- A. Conduct and maintain a geotechnical and structural instrumentation and monitoring program throughout the microtunneling operations. Refer to Section 02445 for instrumentation and monitoring requirements.

3.6 DAILY LOGS AND RECORDS

- A. The contractor shall record and submit logs and records as required in this Specification.

3.7 FIELD PIPE TESTING

- A. The Contractor shall conduct field pipe quality tests after the microtunneling operations are complete.
- B. Groundwater leakage shall be 1 gpm or less into the casing for cumulative inflow.

3.8 SAFETY AND AIR QUALITY

- A. The Contractor shall assume full responsibility for construction safety on all the work

- sites at all times. Methods of construction shall be such as to ensure the safety of all operations, construction and other employees on site, and the public. All job sites shall be maintained to be free from any hazardous and potentially hazardous conditions.
- B. The Contractor shall comply with all current Federal, State, and local laws, regulations, and codes that are pursuant to the execution of this project.
 - C. No gasoline-powered equipment shall be permitted in jacking and receiving shafts. Diesel, electrical, hydraulic, and air powered equipment is acceptable, subject to applicable Federal, State, and local regulations.
 - D. Air Quality:
 - 1. The Contractor shall conduct excavation operations by employing methods and equipment that will positively control dust, fumes, vapors, gases, mists, and other airborne impurities in accordance with applicable regulations.
 - 2. The Contractor shall furnish and operate a temporary ventilation system in accordance with applicable requirements when personnel are in the shafts or the tunnel. Provide test instruments conforming to OSHA regulations and test the underground atmosphere in accordance with OSHA regulations as frequently as necessary to ensure that the required air quality and quantity is maintained. Test results shall be recorded in the Contractor's daily log and posted at points of entry into the microtunnel. In the event that unsafe operating levels are encountered the Contractor shall inform the Engineer immediately.
 - 3. The Contractor shall maintain a logbook of all test results including date, time, location, test personnel and all other relevant information.

3.9 CLEANUP

- A. After completion of microtunneling and pipe installation, all construction debris, slurry, oil, grease, and any other waste materials shall be removed from the pipe, shafts, and work areas.
- B. All surface improvements damaged or removed as a result of the Contractor's operations shall be reconstructed to the same dimensions, except for pavement thickness, and with the same type materials used in the original Work. Pavement resurfacing shall be one (1.0) inch greater in thickness than the existing unless otherwise shown on the Contract Documents.
- C. Restoration shall follow construction as the Work progresses and be completed no later than 30 days after the carrier pipe is installed. Any testing or further inspection necessary for final completion and inspection of the pipe shall not be cause for any delay of restoration Work required under this Contract. This provision for restoration shall include all property that was affected by the construction operations. Such final restoration that cannot be performed within the 30-day period due to adverse weather conditions may upon written request, including a proposed procedure and time schedule, be performed as accepted by the Engineer. Any delayed restoration will be contingent upon providing suitable safe temporary facilities without inconvenience or nuisance in the interim.

****END OF SECTION****

SECTION 02715

CARRIER PIPE INSTALLATION INTO CASING

PART 1 – GENERAL

1.1 REQUIREMENTS

- A. This section specifies minimum design and performance requirements for the installation and grouting of carrier pipe within casing constructed previously using trenchless construction tunneling methods.
- B. Furnish all designs, tools, equipment, materials, and supplies and perform all labor required to complete the Work as indicated on the Contract Drawings and as specified herein.

1.2 REFERENCE CODES, AND STANDARDS

- A. Comply with the following industry standards effective at time of bid:
 - 1. Standard Specifications for Public Works Construction (SSPWC), Section 306-3.

1.3 DEFINITIONS

- A. For additional definitions refer to Section 02623.
- B. Grouting: Injection of cellular grout within the annular space between the carrier pipe(s) and the casing pipe.
- C. Carrier Pipe Support: Pre-manufactured means to allow alignment of the carrier pipe within the casing and to prevent the movement of the carrier pipe during backfill grouting.
- D. Casing Spacers: Pre-manufactured, engineered, carrier pipe supports attached to the carrier pipe, advanced with the carrier pipe and used to set the carrier pipe to design line and grade within a casing. Spacers shall include legs that support the weight of the carrier pipe and risers that prevent buoyancy. Casing spacers slide along near the casing invert and maintain their integrity.
- E. Cellular Grout: A lightweight cementitious material that contains stable air or gas cells uniformly distributed throughout the mixture in amounts greater than 20 percent and is suitable for complete backfilling of the void space between carrier pipe and casing pipe.

1.4 DESIGN REQUIREMENTS

- A. Carrier pipe configuration within casing shall be as shown on the Contract Documents.
- B. Casing spacers shall be used for carrier pipe supports. The use of saddles, blocking, skids and centralizers shall not be permitted.

- C. Casing spacers shall be used in even numbers and with constant spacing such that no support is located directly under the bottom point of the carrier pipe.
- D. Casings spacers shall be located symmetrically around the vertical axis of the carrier pipe.
- E. Carrier pipe supports shall be designed to withstand the total weight of the carrier pipe plus the weight of water within the completely filled carrier pipe with a factor of safety of at least 2.0.
- F. Calculate the maximum anticipated construction loads, buoyancy, backfill grouting pressure and stresses due to the heat of hydration that might be imposed on the carrier pipe, and ensure that anticipated loads are incorporated into the manufacturer's design of the carrier pipe subject to the Engineer's review.
- G. Limit the heat generated by the hydration of the cellular grout to avoid damage and deflection of the pipe.
- H. Cellular grout batching, mixing and pumping equipment shall be compatible and of sufficient size and capacity to place cellular grout to distances and volumes proposed.
- I. The maximum height of each lift of cellular grout shall no exceed 80 percent of the maximum elevation recommended by the carrier pipe manufacturer, measured at the deep end of the pipe.

1.5 PERFORMANCE REQUIREMENTS

- A. Carrier pipe shall be installed within the following tolerances:
 - 1. Line tolerance: plus or minus one (± 1.0) inch of design line.
 - 2. Grade tolerance: 3/4-inch for each 100 feet of pipeline, or a total grade tolerance of 0.05 feet between manholes.
- B. No high or low points shall occur along the installed carrier pipe other than as shown on the Contract Documents.
- C. Carrier pipe shall be free draining along the pipe invert without depressions that hold water with depth greater than 3/4-inch.
- D. The carrier pipe shall be capable of meeting the design flow.

- E. Carrier pipe supports shall prevent the movement of the carrier pipe during backfilling.
- F. The casing shall be free of standing water and groundwater inflows prior to backfill grouting.
- G. The annular space between the carrier and casing pipe shall be completely filled with cellular grout during backfilling.

1.6 QUALITY ASSURANCE

- A. Requirements outlined below shall be met at the time of bid and remain in force through completion of the project. Subcontracted work does not qualify as experience.
 - 1. The Contractor installing the carrier pipe shall have at least 5 (5) years of carrier pipe installation and backfill grouting experience and shall have successfully completed:
 - a. Three (3) projects involving installation and backfill grouting of carrier pipes inside casings.
 - b. Three (3) projects involving installation and backfill grouting of carrier pipes inside casings with the same carrier pipe material as specified for this project.
 - c. At least three (3) projects involving installation and backfill grouting of at least 250 feet of carrier pipe installed within a casing.
 - 2. Project Superintendent shall have:
 - a. A minimum of five (5) years of experience in the installation and backfill grouting of carrier pipes inside casings.
 - b. A minimum of three (3) trenchless construction projects, with at least one project being at least 250 feet long.
 - c. Successfully completed two (2) projects involving the installation and backfill grouting of carrier pipes within a casing.
 - 3. Operator shall have:
 - a. A minimum of three (3) years of experience in the installation and backfill grouting of carrier pipes inside casings.

- b. A minimum of three (3) trenchless construction projects, with each project consisting of at least 250 feet of carrier pipe installation and backfill grouting inside casings.
 - c. Successfully completed two (2) projects involving installation and backfill grouting of carrier pipes inside casings with the same carrier pipe material as specified for this project.
 - d. Operated equipment similar to the one proposed for this project.
4. Surveyor shall be a Professional Land Surveyor registered in the State of Colorado with experience in underground surveying. Experience shall include:
 - a. Three (3) tunnel projects within the last five (5) years,
 - b. Transfer of points and line from the surface to below ground,
 - c. Closed loop tunnel survey for line and grade.
5. Experience records shall list the three (3) most recent carrier pipe installation projects, including all such projects completed for the City, and all projects demonstrating the specified experience. Each experience record shall include name of project; owner of the project; names of contacts including all contact information; carrier pipe material used; carrier pipe diameter; casing pipe internal diameter and longest laying length.
6. The Engineer will be the sole judge in determining if the prospective contractor, project superintendent and operator meet the aforementioned work and project experience requirements.

1.7 CONTRACTORSUBMITTALS

- A. Submittals shall be made in accordance with Section 4.19 of the General Provisions, Section 15 of the Special Provisions and as specified herein.
- B. Carrier pipe installation submittals shall be coordinated with all relevant submittals, assembled and submitted as a single, comprehensive submittal.
- C. Where calculations are required to be submitted, they shall be signed and sealed by a Professional Civil Engineer registered in the State of Colorado. Calculations shall clearly identify all parameters used, state all assumptions made in the calculation, and identify all sources of information.
- D. All shop drawings shall be legible with dimensions accurately shown and clearly

marked in English.

E. Pre-Construction Submittals:

1. Detailed carrier pipe-laying schedule, include backfill grouting. Schedule shall be coordinated with overall schedule for the Project.
2. Qualifications and experience records for the following:
 - a. Contractor performing the Work;
 - b. Project superintendent;
 - c. Operator;
 - d. Contractor's surveyor.
3. Work plan describing proposed procedures, materials and equipment to transport carrier pipe from the surface into its final position.
4. Manufacturer's preprinted specifications and operating instructions for proposed pipe carrier system or jacking equipment.
5. Work plan describing proposed procedures and equipment for placement of cellular grout including the number of lifts, pumping pressures and pumping rates.
6. Manufacturer's preprinted specifications and operating instructions for grouting equipment, including pumps, foam generators and ancillary equipment.
7. Written confirmation from the carrier pipe manufacturer that the pipe wall and joint configuration to be supplied are appropriate for and consistent with the Contractor's proposed means and methods.
8. Written handling instructions from the carrier pipe manufacturer.
9. Design calculations for carrier pipe supports. Clearly state their respective spacing assumed in the calculations. If carrier pipe support design calculations are signed and sealed by a Professional Engineer who is a staff member of the manufacturer, professional engineering registration in the State of Colorado is not required.
10. Shop drawing showing carrier pipe and pipe joint detail.
11. Shop drawings showing details of all carrier pipe supports proposed for use.

12. Shop drawing showing injection pipe and return vent locations.
13. Shop drawing showing end seal and bulkhead details.
14. Description of testing procedures for the cellular grout in accordance to Section 03360.
15. Calculations of maximum anticipated construction loads, buoyancy and backfill grout injection pressure that might be imposed on the carrier pipe. Indicate maximum allowable grout injection pressure.
16. Description of method for monitoring grout mix temperature and pumping pressure.
17. Calculation of estimated total cellular volume, volume of cellular grout for each lift, and not to exceed the maximum allowable lift height.
18. Calculation of heat generated by hydration of cellular grout and design calculations for heat control for each grout mix proposed for use. Include carrier pipe manufacturer's written recommendations for the maximum allowable heat of hydration.
19. Description of method for monitoring and controlling the heat of hydration of the cellular grout.
20. Layout shop drawing of job site showing all major equipment above ground and in the shaft, include carrier pipe staging areas and pump arrangements.
21. As-built survey of casing pipe in both tabular format and AutoCAD format acceptable to the Engineer. Scale to be acceptable to the Engineer. Survey shall confirm that carrier pipe can be installed within design tolerances.
22. Design profile of carrier pipe placement showing carrier pipe supports.
23. Description of the means and methods of maintaining alignment of the carrier pipe within design tolerances during carrier pipe installation and preventing the movement of the carrier pipe during backfill grouting.
24. Method of direct communication between the grout injection point and the pump operator during backfill grouting.
25. Electrical system, lighting system, and onsite power generation details.
26. Shaft and pipe ventilation system details including fan size and operating

parameters.

27. Potable water sources, handling and disposal.

F. Construction Submittals:

1. Daily installation logs with the following information:

- a. Date.
- b. Project name.
- c. Start and finish times for each shift.
- d. Location of pipe by station.
- e. Printed name of operator and signature.
- f. Number of carrier pipe segments installed.
- g. Carrier pipe support ID and location.
- h. Any unusual conditions or events.

2. Daily grouting logs with the following information:

- a. Date.
- b. Project name.
- c. Start and finish times for each shift.
- d. Location of grout injection.
- e. Time of grout injection.
- f. Volumes of grout placed.
- g. Stationing of grout placement.
- h. Injection pressures.
- i. As-cast unit weight results.
- j. Designation of cylinder samples prepared during shift.

3. Graphical or digital printout records of batch scale readings, accurate to one (1.0) pound, of the dry mix ingredients before delivery to mixer.
 4. Provide all logs by 9 AM the following work day.
- G. Post-Construction Submittals:
1. As-built survey of installed carrier pipe in both tabular format and AutoCAD format acceptable to the Engineer. Scale to be acceptable to the Engineer.

1.8 SAFETY

- A. Train all non-contractor project staff in shaft and tunnel entry operations prior to entry.

PART 2 – PRODUCTS

2.1 MATERIALS

- A. Provide carrier pipe in accordance with Section 02715 with minimum diameter and wall thickness as shown on the Contract Documents.
- B. Provide cellular grout in accordance with Section 03360.

2.2 EQUIPMENT

- A. Provide a means of direct communication between the injection point and the pump operator during backfilling.
- B. Provide equipment capable of satisfactorily mixing, agitating, and forcing cellular grout into injection ports at a uniform flow rate under the required constant pressure.
- C. Configure backfill grouting equipment so that flushing can be accomplished with grout intake valves closed, with water supply valve open, and with grout pump running at full speed.
- D. Provide a timer-controlled foam generator to repetitively discharge a preselected quantity or to discharge continuously at a fixed rate. Foam generating equipment shall be tested and calibrated for dilution percentage, density, and volume output.
- E. Provide high side vent pipe in the tunnel crown to allow entrapped air to escape during backfill grouting.

- F. Provide chiller pipes within cooling water as required by the Contractor's design to limit the heat of hydration.
- G. Provide variable speed water pumps, pipe plugs, valves, and sump pumps necessary to continuously flow cooling water through the carrier pipe until the heat of hydration has subsided to a level deemed safe by the pipe manufacturer.

2.3 ENDSEALS AND BULKHEADS

- A. End Seals shall be specifically manufactured for the installation.
- B. Bulkheads shall be field-fitted of brick and mortar.
- C. Materials shall be compatible with the injection of cellular grout.

PART 3 – EXECUTION

3.1 GENERAL

- A. Carrier pipe installation and backfill grouting shall be performed in accordance with accepted submittals.

3.2 INSTALLATION OF CARRIER PIPE

- A. Carrier pipe installation shall not commence until backfill grouting of the annulus of the casing has been completed and casing has been cleaned following backfill grouting.
- B. Perform as-built survey of the casing and demonstrate the ability to install carrier pipe within design tolerances prior to commencing carrier pipe installation.
- C. Mount carrier pipe to carrier pipe supports/centralizers to allow for proper alignment of the carrier pipe within design tolerances and to provide the required clearance between the casing and carrier pipes as specified herein.

3.3 BACKFILL GROUTING BETWEEN CARRIER PIPE AND CASING

- A. Prior to grouting, where pre-assembled carrier pipe is used, pipe string shall have passed an initial pressure and leakage test.
- B. The carrier pipe support shall prevent pipe flotation during grouting. All anti-buoyancy measures shall be in place prior to the commencement of grouting.

- C. Construct bulkheads between the carrier and casing pipes at each end of the carrier pipe and at each end of each reach of pipe to be backfilled in the same step to retain grout during backfilling.
- D. Ends of the casing pipe shall be sealed with an end seal or bulkhead prior to grouting.
- E. Carrier pipe shall be completely full of flowing water at all times during and following grouting operations until cellular grout is fully cured. Continuously flow water from the low to high point of the carrier pipe at a flow rate necessary to prevent damage to the carrier pipe.
- F. Place cellular grout in lifts to minimize flotation and heat generation.
- G. Volume of cellular grout injected shall be measured, recorded and compared with the anticipated volume per foot of pipe backfilled.
- H. Monitor flow rate and temperature gain in cooling water in the carrier pipe during grouting and limit the heat of hydration as to not exceed the maximum allowable temperature in accordance with carrier pipe manufacturer's recommendations. Place cooling water temperature probes at ends of carrier pipe.
- I. Monitor as-cast unit weight of cellular grout at the point of placement.
- J. Grout placement shall be continued until at least one (1.0) cubic yard of cellular grout overflows to ensure complete filling of carrier pipe annulus.
- K. Perform final acceptance testing of the completed pipe string upon completion of backfill grouting.

****END OF SECTION****

PART 1 – GENERAL

1.1 SECTION INCLUDES

- A. This section covers ground preparation for all areas disturbed by construction activities.
- B. This section addresses work within the limits of disturbance as shown on the Drawings. However, if disturbance does occur outside of this designated area, this section will also pertain to those areas, which have been disturbed.
- C. See Sections 02300 and CDOT Standard Specifications 207 and 212 for additional detail.

1.2 INITIAL INSPECTION

- A. The CONTRACTOR will inspect existing site conditions and note irregularities affecting work of this section. Verify that grading operations have been satisfactorily completed and that topsoil of adequate quantity and quality has been replaced in all areas as specified. Verify that the area to be revegetated is protected from concentrated runoff and sediment from adjacent areas. Note any previous treatments to the area such as temporary seeding or mulching and discuss how these treatments will affect permanent revegetation with the ENGINEER. Report all irregularities affecting work of this section to the ENGINEER before beginning work. Beginning work of this section implies acceptance of existing conditions.

1.3 CLEANING

- A. Perform cleaning daily during installation of the work, and upon completion the work. Remove and haul from the site all excess materials, debris, and equipment. Repair damage resulting from ground preparation operations.

PART 2 – PRODUCTS

2.1 FERTILIZER

- A. Fertilizer to comply with Section 212 of 2011 Edition Standard Specifications for Road and Bridge Construction by Colorado Department of Transportation.

2.2 TOPSOIL

- A. Topsoil to comply with Section 207 of 2011 Edition Standard Specifications for Road and Bridge Construction by Colorado Department of Transportation.

PART 3 – EXECUTION

3.1 GENERAL SOIL PREPARATION

- A. Verify that the area has been prepared as per Section 02220.
- B. Till and fertilize areas to be disturbed.
 - 1. Thoroughly till the ground to a depth of 4 inches after areas have been cleared and brought to grade.
 - a. Work the soil only when moisture conditions are suitable.
 - 2. Mix fertilizer into top 2 to 3 inches of soil by harrowing or tilling.
 - 3. Remove rocks and other objects over 2 inches in diameter.
 - 4. Correct irregularities in the ground surface resulting from soil preparation operations and slope to drain.
- C. Apply topsoil to a depth of four (4) inches in accordance with Section 207 of 2011 Edition Standard Specifications for Road and Bridge Construction by Colorado Department of Transportation.
- D. Inspection: Examine the substrate in which the work is to be performed. Do not proceed until unsatisfactory conditions have been corrected.
- E. Grades: Grades have been established under work of another Section to within 1 inch, plus or minus, of required finished grades. Verify that grades are within 1 inch, plus or minus, of required finished grades. Notify the ENGINEER prior to commencing soil preparation work if existing grades are not satisfactory, or assume responsibility for conditions as they exist.
- F. Weed and Debris Removal: All ground areas to be planted shall be cleaned of all weeds and debris prior to any soil preparation or grading work. Weeds and debris shall be disposed of off the site.
- G. Contaminated Soil: Do not perform any soil preparation work in areas where soil is contaminated with cement, plaster, paint or other construction debris. Bring such areas to the attention of the ENGINEER and do not proceed until the contaminated soil is removed and replaced.
- H. Moisture Content: Soil shall not be worked when moisture content is so

great that excessive compaction will not occur, nor when it is so dry that dust will form in the air or that clod will not break readily. Water shall be applied, if necessary, to bring soil to an optimum moisture content for tilling and planting.

- I. Ripping & Scarification: Rip, scarify, or otherwise loosen all areas to a depth of 6 inches, removing all obstructions encountered in excavating, such as loose rock, construction debris, etc. Thoroughly till all areas which are to be seeded that previously supported vehicular traffic to a depth of 12". Till all remaining areas to a depth of 6". Channel bottom areas are to be ripped to a depth of at least 2 feet on approximately 2- to 4-foot centers. Work the soil only when moisture conditions are suitable. Remove rocks and other objects 3" or greater in any dimension.
- J. Soil Conditioning: After soil preparation has been completed and high and low spots graded, add soil amendments as indicated above and rototill, making repeated passes with the cultivator to the depth specified until the amendments have been thoroughly mixed.

END OF SECTION

PART 1 – GENERAL

1.1 DESCRIPTION

- A. This section covers soil preparation, fertilizing, seeding, and mulching of areas disturbed by construction.
- B. Planting of seed shall be performed only when weather, soil conditions, and planting seasons are suitable as determined by professional horticulturists in accordance with local practice. Planting seasons shall be understood to comprise that period of time in the spring and fall, respectively, favoring the healthy growth of grass in the locality in which the seeding is to be done in accordance with accepted horticultural practice.
- C. All land where construction activities have obliterated or injured the existing vegetative ground cover shall be restored.

1.2 QUALITY ASSURANCE

- A. Source Quality Control: Manufacturer's test for purity and germination of seed, dated within six months of seeding.
- B. All seeding work shall be performed by a landscape contractor who is experienced and qualified in the work required and in utilizing equipment required to perform this work

1.3 SUBMITTALS

- A. Certificates: Manufacturer's certification that materials meet specification requirements.
- B. Test Reports: Results of seed purity and germination tests.

1.4 PRODUCT DELIVERY, STORAGE AND HANDLING

- A. Do not deliver precast concrete sections until the concrete has attained at least 80 percent of its specified strength.

PART 2 – PRODUCTS

2.1 SEED

- A. Seed mix and application rates shall be as follows:

COMMON NAME	BOTANICAL NAME	LBS. PLS PER ACRE
Indian Ricegrass	<i>Achnatherum</i> <i>[Oryzopsis]</i> <i>hymenoides</i>	3.7
Sand Dropseed*	<i>Sporobolus cryptandrus</i>	0.1
4-Wing Saltbush	<i>Atriplex canescens</i>	2.7
Shadscale	<i>Atriplex confertifolia</i>	2
And At Least Two of the Following		
Salina Wildrye	<i>Leymus salinus</i>	1
Alkali Sacaton*	<i>Sporobolus airoides</i>	1
Western Wheatgrass	<i>Pascopyrum</i> <i>[Agropyron] smithii</i>	1.5
And at Least One of the Following		
Bottlebrush squirreltail	<i>Elymus elymoides,</i> <i>Sitanion hystrix</i>	2
Galleta	<i>Pleuraphis jamesii</i>	1
Purple Three-Awn	<i>Aristida purpurea</i>	1
TOTAL		Min – 11.5 Max - 13.0

- B. Seeding of the borrow site will be as directed by the OWNER. Seeding shall be a local native field seed mix as directed by the OWNER.

2.2 MULCH

- A. Straw only. 1.5 tons per acre. Apply to 3:1 slopes and flatter.

2.3 SOIL RETENTION COVER

- A. Install ST-2 or EX-2 grade erosion control blanket on all slopes meeting 3:1 or greater and moderate flow ditches as determined by the ENGINEER. Install within 24 hours of seeding.

PART 3 – EXECUTION

3.1 SOIL PREPARATION

- A. Verify soil preparation has been completed in accordance with Section 02934 – Soil Preparation.

3.2 SEEDING

- A. Apply by broadcasting or drilling at the rate specified herein.
 - 1. Rework previously prepared areas that have become compacted or damaged by rains or traffic.
 - 2. Do not drill or sow during windy weather or when ground is frozen or unfillable.
 - 3. Drill seed 0.25 inch to 0.5 inch into the soil. In small areas not accessible to a drill, hand broadcast or hydroseed at double the rate and rake 0.25 inch to 0.5 inch into the soil per CDOT subsection 212.
- B. Cover seed to depth between $\frac{1}{4}$ to $\frac{1}{2}$ inch by raking or harrowing.
- C. Firm seeded areas with roller weighing maximum of 100 lbs per foot of width.

3.3 MULCHING

- A. Apply a minimum of 2 tons of certified weed free hay or 2 1/2 tons of certified weed free straw per acre and in accordance with CDOT Section 213, and mechanically crimp it into the soil in combination with an organic mulch tackifier.
- B. Prior to winter shutdown or the summer seeding window closure per CDOT Section 212: Uncompleted slopes shall be mulched with 2 tons of mulching (weed free) per acre, mechanically crimped into the topsoil in combination with an organic mulch tackifier per CDOT subsections 208 and 213.
- C. Apply "Soil Retention Cover" on slopes of 3:1 and steeper as per the "Standard Specifications" referenced above.

3.4 HYDRAULIC SEEDING AND MULCHING

- A. Due to high failure rates, hydroseeding will not be allowed for permanent stabilization.

3.5 SOIL CONDITIONING AND FERTILIZER REQUIREMENTS

- A. Minimum requirements for all disturbances to receive seeding (native). [Elevation: (4,520) feet:

Soil conditioner paid for as Item 212- Soil Conditioning (Acre)			
Biological nutrient organic based fertilizer (lbs/acre)*	Humate (lbs/acre)	Compost (cys/acre)	Spray on Amendment (lbs/acre)
		All areas <2:1	>2:1 slopes only
300	200	65	3500

*Biological nutrient shall not exceed 8-8-8 (N-P-K).

Humate based material shall be in accordance to Standard Special Provision 212 and compost shall be in accordance to CDOT Standard Special Provision 212.

3.6 RESEEDING AND REPAIR

- A. Reseed and mulch areas where there is not a satisfactory stand of grass at the end of one (1) year after seeding. Reseed and mulch a second time if a satisfactory stand of grass is not obtained one (1) year after the first reseeding and mulching.
- B. All seeded areas shall be reviewed during the fourteen (14) day inspections by the SWMP Administrator and or Erosion Control Inspector for bare soils caused by surface or wind erosion. Bare areas caused by surface or gully erosion, blown away mulch, etc. shall be re-graded, seeded, and have the designated mulching applied as necessary, at no additional cost to the project.
- C. Minimum satisfactory stand: 4 plants per square foot.

3.7 PRIOR TO FINAL ACCEPTANCE

- A. Partial Acceptance shall be in accordance with CDOT subsection 107.25 (d), 208.10 and 214.04 at the Partial Acceptance of the project, it shall be determined by the SWMP Administrator and the ENGINEER which temporary BMPs/Control Measures shall remain until 70% revegetation is established or which shall be removed.

END OF SECTION

DIVISION 3
CONCRETE

PART 1 – GENERAL

1.1 DESCRIPTION

- A. This Section covers furnishing, erecting and removing of forms for cast-in-place concrete.

1.2 QUALITY ASSURANCE

- A. Reference Standards.
1. American Concrete Institute Standards (ACI).
 - a. 301 Specifications for Structural Concrete for Buildings, Chapter 4, Formwork.
 - b. 347 Recommended Practice for Concrete Formwork (Chapters 1 through 5).
 - c. As modified herein.
- B. Design Criteria.
1. Design formwork for the loads, lateral pressure and allowable stresses outlined in Chapter 1 of ACI 347.
- C. Maximum Allowable Tolerances.
1. Variation from plumb.
 - a. Lines and surfaces of columns, piers and walls.
 - 1) In any 10 feet of length 1/4 inch
 - 2) Entire length 1 inch.
 - b. Exposed corner columns, control-joint grooves, and other conspicuous lines.
 - 1) In any 20 feet of length 1/4 inch.
 - 2) Entire length 1/2 inch.
 2. Variation from level or specified grade.
 - a. Slab soffits, beam soffits and ceilings.
 - 1) In any 10 feet of length 1/4 inch.
 - 2) In any bay or in any 20 feet of length 3/8 inch.
 - 3) Entire length 3/4 inch.
 3. Variation of the linear building lines from established position in plan and related position of columns, walls and partitions.
 - a. In any bay 1/2 inch.
 - b. In any bay or in any 20 feet of length 1/2 inch.
 - c. Entire length 1 inch.
 4. Refer to ACI 301, Table 4.3.1 for additional requirements.
 5. Forms for exposed surfaces shall produce finished surfaces that are free from offsets, ridges, waves and concave or convex areas. The maximum deviation from a true plane shall not exceed 1/8 inch in 6 feet.

PART 2 – PRODUCTS

2.1 FORM MATERIALS

- A. General: for concrete and cementitious coating finishes where "Smooth Form Finish", is specified, use prefabricated plywood panel forms, job-built plywood forms, forms lined with plywood or fiberboard, or steel forms. Where "Rough Form Finish" is specified, unlined wooden forms may be used. Earth shall not be used as a sideform.
- B. Steel Forms:
 - 1. Symons "Steel-Ply", Simplex "Industrial Steel Frame Forms", Universal "Uniform" or equal.
- C. Plywood forms:
 - 1. Product Standard PSI, - waterproof, resin-bonded exterior type Douglas fir.
- D. Fiberboard forms:
 - 1. Federal Spec. LL-B-810 - Type II tempered, waterproof, screenback, concrete form hardboard.
- E. Lumber:
 - 1. Straight, uniform width and thickness, free from knots, offsets, holes, dents, and other surface defects.
- F. Chamfer strips:
 - 1. Clear white pine, surface against concrete planed.
- G. Form ties:
 - 1. Removable end, permanently embedded body type.
 - 2. Sufficient strength and rigidity to support and maintain the form in proper position and alignment without the use of auxiliary spreaders.
 - 3. Breakback Cones:
 - a. 1" breakback cone ties with waterstops are required on below grade basins and pump rooms.
 - 4. Permanently embedded type without threaded ends shall be so constructed so that removable ends are readily broken off (one inch back from concrete surface) without damage to the concrete.
 - 5. Form ties in exposed surfaces shall be uniformly spaced and aligned in horizontal and vertical rows.
- H. Joints.
 - 1. Keyed joints in slabs on grade may be formed using 24 gage galvanized screed key joints of indicated slab depth and steel stake supports at 24 inch maximum centers.

- I. Wedge inserts.
 - 1. Malleable iron, with galvanized askew-head bolts, nuts and washers; Hohmann and Barnard "type HW"; Richmond Screw Anchor, "Peerless"; Weston Co., "WC 50", or equal.
- J. Polyethylene film:
 - 1. Product standard PS17; 8 mil.
- K. Form coating.
 - 1. Non-staining chemical release agent that will not damage the concrete surface.
 - 2. For all exposed surfaces not in contact with earth backfill use Protex Industries "Pro-Cote", Symons Corp., "Magic Kote", L & M "Debond" or equal.

2.2 ACCESSORIES

- A. Formliners
 - 1. General
 - a. Formliners shall mimic the wall sections of the headworks building. Split face formliner block shall be constructed to a height of 7' – 4" (Reference Drawing A301) and ground face formliner shall be constructed above the split face formliner to the top of the SBR basin walls.
 - 2. Materials
 - a. ABS Plastic, up to 15 reuses
 - 3. Split face formliner
 - a. Manufacturer
 - 1) Fitzgerald Formliners, Pattern 16971
 - 2) Or Equal
 - 4. Ground face formliner
 - a. Manufacturer
 - 1) Fitzgerald Formliners, Pattern 16949
 - 2) Or Equal

PART 3 – EXECUTION

3.1 ERECTION

- A. General.
 - 1. Erect forms substantial and sufficiently tight to prevent leakage of mortar and braced or tied to maintain the desired position, shape and alignment before, during and after concrete placement.
 - 2. Use adequate walers, stiffeners and braces to insure proper alignment.

3. Provide temporary openings at the bottom of column and wall forms and at other locations where necessary to facilitate cleaning and inspection.
4. Temporary openings in wall or column forms used to limit the free fall of concrete to a maximum of 4 feet shall be located to facilitate placing and compaction of the concrete. Such openings in walls shall not exceed 10 feet laterally to avoid moving concrete laterally more than 5 feet.
5. If tremies of proper lengths are used for depositing concrete in walls or columns, temporary openings for concrete placement will not be required.
6. Whenever the top of a wall will be exposed to weathering, do not extend the forms on one side above the top of the wall; bring to true line and grade.
7. At other locations, bring forms to a true line and grade, or provide a wooden guide strip at the proper location on the forms so that the top surface can be finished with a screed or template for concrete which is to have a specified elevation, slope or contour.
8. At horizontal construction joints in walls, do not extend the forms on one side more than 2 feet above the joint. When slab dowels project beyond face of forms, cut or drill forms to allow dowels to pass. Do not bend dowels to accommodate forming unless noted on drawings.
9. Flat segmental forms not more than 24 inches wide may be used for forming curved surfaces 25 feet in diameter or larger.
10. Where concrete is placed against rock, remove all loose pieces of rock and clean the exposed surface with a high pressure hose.

B. Embedded items.

1. Anchor bolts, castings, steel shapes, conduits, sleeves, masonry anchorage and other materials that are to be embedded in the concrete shall be accurately positioned in the forms and securely anchored.
2. In walls or slabs with reinforcement in both faces, install conduits between the two faces of reinforcing steel.
3. In slabs and wall which have only a single face of reinforcing steel, place conduits near the center of the slab.
4. Unless installed in pipe sleeves, provide anchor bolts with sufficient threads to permit a nut to be installed on the concrete side of the form or template.
5. Install a second nut on the other side of the form or template and adjust the two nuts so the bolt will be held rigidly in proper position.
6. Assure embedments are clean when installed.
7. After concrete placement, clean surfaces not in contact with concrete or concrete mortar and other foreign substances.

- C. Preparation of form surfaces.
1. Remove mortar, grout, and other foreign material from form surfaces.
 2. Coat form surfaces with form coating material before either the reinforcing steel or concrete is placed.
 3. Do not allow form coating to:
 - a. Stand in puddles in the forms.
 - b. Come in contact with the reinforcing steel or waterstops.
 - c. Come in contact with adjacent hardened concrete against which fresh concrete is to be placed.
- D. Edges and corners.
1. Place chamfer strips in forms to bevel all exposed edges and projecting corners. Chamfer the top edges of walls and slabs not indicated on the Drawings to be beveled.
 2. Form chamfered edges for all vertical and horizontal corners of equipment bases.
 3. Chamfer strips shall be 3/4 inch unless indicated otherwise on the Drawings.
- E. Removal.
1. Do not remove or disturb forms until the concrete has attained sufficient strength to safely support all dead and construction loads.
 2. For beams, slabs and similar sections determine strength from job cured cylinder breaks. Cylinders to be job cured in same manner as the formed concrete.
 3. Retain shoring in place and reinforce as necessary to carry any construction equipment, materials or other loads in excess of cured strength.
 4. Use care in form removal to avoid surface gouging, corner, or edge breakage, and other damage to concrete.
 5. Do not commence form removal earlier than the following schedule:
 - a. Walls not yet supporting loads: 24 hours
 - b. Vertical sides of beams and girders: 24 hours
 - c. Bottom forms and shoring for slabs under 10 feet clear span between supports: 7 days
 - d. Bottom forms and shoring for slabs between 10 to 20 feet clear span: 14 days
 - e. Bottom forms and shoring for slabs 20 feet clear span: 21 days
 - f. Refer to ACI 347, Chapter 2, paragraph 2.7.2.3. for additional requirements.
 6. In cold weather below 15 F, defer the removal of formwork or replace the formwork with insulation blankets to avoid thermal shock and consequent cracking of surface.

END OF SECTION

PART 1 – GENERAL

1.1 DESCRIPTION

- A. This Section covers furnishing and installing steel bars, dowel bar splicers, and welded wire fabric for concrete reinforcement.

1.2 QUALITY ASSURANCE

- A. Reference Standards:
1. American Concrete Institute Standards (ACI).
 - a. 301 Specifications for Structural Concrete for Buildings.
 - b. 315 Manual of Standard Practice for Detailing Reinforced Concrete Structures.
 - c. 318 Building Code Requirements of Reinforced Concrete.
 2. As modified herein or on the Drawings.
- B. Allowable tolerances.
1. Fabrication tolerances.
 - a. Sheared length: ± 1 inch.
 - b. Depth of truss: +0, -1/4 inch for concrete thickness 24 inches or less and +0, -1/2 inch for concrete thickness over 24 inches.
 - c. Overall dimensions of stirrups, ties and spirals: +0, -1/4 inch for concrete thickness 24 inches or less and +0, -1/2 inch for concrete thickness over 24 inches.
 - d. All other bends: ± 1 inch.

1.3 SUBMITTALS

- A. Shop Drawings.
1. Show sizes, quantity and dimensions for fabrication and placing of reinforcing bars and bar supports.
 2. Indicate bar schedules, stirrup spacing, and diagram of bent bars.
 3. Indicate concrete cover dimensions to concrete surface.
- B. Certificates.
1. Mill test certificates identifying chemical and physical analysis of each load of reinforcing steel delivered.
- C. Submit the following additional information for threaded dowels and threaded receivers.
1. Sizes, quantities, dimensions and locations.
 2. Type of rust inhibitive.
 3. Ultimate load test data for each size of bar.

4. Mill test certificate identifying chemical and physical analysis of the rebar material.

1.4 PRODUCT DELIVERY, STORAGE AND HANDLING

- A. Deliver to site in bundles marked with metal tags indicating bar size and length.
- B. Carefully handle and store on supports which will keep the steel from coming in contact with the ground.

1.5 ALTERNATIVES

- A. The use of straight or bent threaded dowel substitutes and their corresponding threaded receivers (structural anchor embeds), as shown are required as shown on Drawings, and may be provided at CONTRACTOR's option except in the following locations.
 1. Bottom vertical dowels in the exterior walls and the partition walls.
 2. Beams.
 3. Other locations designated by ENGINEER during construction.

PART 2 – PRODUCTS

2.1 REINFORCEMENT BARS

- A. Bars: ASTM A615, Grade 60 for #5 and larger bars, and grade 40 or grade 60 for #4 and smaller bars.
 1. Bend test: Meet 180 bend at 60 F minimum temperature without cracking when bent around pin diameter indicated.
 - a. Number 3, 4 and 5 bars around pin diameter equal to 4 times nominal bar diameter.
 - b. Number 6 through 11 bars around pin diameter equal to 5 times nominal bar diameter.
- B. Tie wire: Annealed steel, Fed. Spec. QQ-W-461, 16 gage minimum.
- C. Bar Supports:
 1. Conform to "Bar Support Specifications", CRSI Manual of Standard of Practice.
 2. Where concrete surface will be exposed to weather, the portions of the supports or accessories within ½ inch of the concrete surface shall be noncorrosive or protected against corrosion (plastic covered).
- D. Fabrication: in accordance with CRSI Manual of Standard Practice except for the allowable tolerances specified herein in 1.2B.

2.2 WELDED WIRE FABRIC

- A. Welded wire fabric: ASTM A 185 or A497.

2.3 THREADED DOWELS (ALTERNATIVE)

- A. Grade, same as under 2.1.A.
- B. Conformance: ACI 318.
- C. Develop a minimum of 125 percent of the specified yield strength of the reinforcing rebar shown on Drawings.
- D. Spacing: same as on Drawings.
- E. Manufacturers:
 - 1. Richmond Screw Anchor Co., Inc.
 - 2. Dayton Superior Corp.
 - 3. Erico Rebar Splicing.
 - 4. Lenton Formsaver
 - 5. No Substitutions allowed.

PART 3 – EXECUTION

3.1 PREPARATION

- A. Remove all mud, oil, loose rust or mill scale and other foreign materials that may reduce bond.

3.2 INSTALLATION

- A. Bar placement.
 - 1. Conform to CRSI-WCRSI "Placing Reinforcing Steel."
- B. Bar supports.
 - 1. Provide minimum number of supports as required by ACI 315.
 - 2. Do not use pebbles, pieces of broken stone, common or face brick, metal pipe or wood blocks to support reinforcement.
 - 3. Support at 4'-0 max centers unless otherwise shown.
 - 4. Use only plastic bar supports in basins and below grade structures.
- C. Placement tolerances.
 - 1. Clear distance to formed surface: see Drawings.
 - 2. Spacing between bars: -1/4 inch.
 - 3. Top bars in slabs and beams: see Drawings.
 - 4. Crosswise of members: spaced evenly within 2 inches.
 - 5. Lengthwise of members: \pm 2 inches.

6. Maximum bar movement to avoid interference with other reinforcing steel, conduits or embedded items: one bar diameter.
 - a. If bars are moved more than one bar diameter, or enough to exceed the above tolerances, the resulting arrangement of bars may be rejected by ENGINEER.

- D. Concrete cover.
 1. As indicated or scheduled on Drawings.

- E. Reinforcing adjustment.
 1. Move only as stated under 3.2 C 6.
 2. Do not heat, bend or cut bars without ENGINEER's approval.

- F. Splices.
 1. Do not splice bars except at locations shown on Drawings without ENGINEER's approval.
 2. Minimum lap distance shall be as shown on Drawings. If not shown, splices shall be as specified in ACI 318.
 3. Tie splices securely to prevent displacement during placement of concrete.

- G. Welded wire fabric.
 1. Install in longest practicable length.
 2. Lap adjoining pieces one full mesh plus 2 inches minimum.
 3. Do not make laps midway between simply supported members or directly over support members of continuous structures.
 4. Offset laps in adjacent widths to prevent continuous laps.
 5. Extend fabric through contraction joints and construction joints unless otherwise indicated on the Drawings.

- H. Threaded dowels, (Alternative).
 1. Receiver anchor embed: plug during concrete pouring.
 2. Threaded portion of the dowel: dip into rust inhibitive sealant, accepted by ENGINEER, before inserting into the receiver embed. The rest of the dowel in rebar should be clean, dry and clear of foreign material.

- I. Reinforcing Steel Ties
 1. Tie 50% of reinforced intersections at a minimum.

End of Section

PART 1 – GENERAL

1.1 DESCRIPTION

- A. This Section covers cast-in-place concrete, including furnishing materials, transporting, placing, finishing, curing and other appurtenant items of construction.
- B. Inform ENGINEER at least 48 hours in advance of time and places at which CONTRACTOR intends to place concrete, exclusive of weekends and holidays.

1.2 QUALITY ASSURANCE

- A. Reference standards
 - 1. Except as noted or modified in this Section all concrete materials, transporting, placing, finishing and curing shall conform to the requirements of the following standard specifications:
 - a. American Concrete Institute Standards (ACI).
 - 1) 301 Specifications for Structural Concrete for Buildings.
 - 2) 304 Recommended Practice for Measuring, Mixing, Transporting, and Placing Concrete.
 - 3) Committee 304 Placing Concrete by Pumping Methods.
 - 4) 305 Recommended Practice for Hot Weather Concreting.
 - 5) 306 Recommended Practice for Cold Weather Concreting.
 - 6) 309 Recommended Practice for Consolidation of Concrete.
 - 7) 318 Building Code Requirements for Reinforced Concrete.
- B. CONTRACTOR shall keep at least one copy of above listed ACI publications, latest edition, in project field office at all times.

1.3 SUBMITTALS

- A. Test results.
 - 1. Perform and submit test reports for following products in accordance with above general reference standards and specific standards of these specifications.
- B. Proposed mix design.

1. Prior to commencing concrete work submit and obtain ENGINEER's approval of certified test reports describing proposed concrete mix design, including:
 - a. Fine aggregates - source, type, gradation, deleterious substances and bulk specific gravity on basis of weight of saturated surface - dry aggregate. ASTM C128.
 - b. Coarse aggregate - source, type, gradation, deleterious substances and bulk specific gravity on basis of weight of saturated surface -dry aggregate, ASTM C127.
 - c. Ratio of fine to total aggregates.
 - d. Weight (surface dry) of each aggregate per cubic yard.
 - e. Total water content in gallons per cubic yard and proposed source.
 - f. Slump Range on which design is based.
 - g. Brand, type, and quantity of cement.
 - h. Brand, type, descriptive data, and quantity of admixtures.
 - i. Air content range.
 - j. Two sets of trial mix test cylinders, two cylinders per set, shall be made for each proposed mix or provide field experience basis for evaluation per ACI 301. Test one set of two cylinders at age 7 days and other set at 28 days.

- C. Cylinder Compression Test Reports
 1. Submit 2 copies of certified test reports to ENGINEER for 1.3 B.1.j. and 2 copies of each of test results required under 3.9A.

- D. Ready-Mix Delivery Tickets
 1. Submit delivery tickets for each load at time of delivery indicating following:
 - a. Quantity delivered.
 - b. Quantity of each material in batch.
 - c. Outdoor temperature in shade.
 - d. Time at which water was added.
 - e. Elapsed time between when water was added and concrete load was in place.
 - f. Amounts of initial and supplemental water added. Initial w/c ratio.
 - g. Name of individual authorizing supplemental water.
 - h. Numerical sequence of delivery by indicating cumulative yardage delivered on each ticket.
 - i. Mix temperature.

- E. Concrete Construction Jointing Plan
 1. Provide Construction Jointing Plan showing proposed location of wall, footing and slab locations prior to submitting reinforcing shop drawings.

1.4 PRODUCT DELIVERY, STORAGE, AND HANDLING

- A. Cement
 - 1. Store in weather tight enclosures and protect against dampness, contamination and warehouse set.
 - 2. Do not use cement that has become caked or lumpy.
- B. Aggregates
 - 1. Stockpile to prevent excessive segregation, or contamination with other materials or other sizes of aggregates.
 - 2. Use only one supply source for each aggregates stock pipe.
 - 3. The bottom 6 inches of all aggregate piles in contact with ground shall not be used.
- C. Admixtures
 - 1. Store to prevent contamination, evaporation, or damage.
 - 2. Protect liquid admixtures from freezing or harmful temperature ranges.
 - 3. Agitate emulsions prior to use.
- D. Rubber and Plastic Materials
 - 1. Store in cool place away from direct sunlight.
- E. Mixing and transporting ready-mixed concrete
 - 1. Maximum elapsed time from time water is added to mix until concrete is in place shall not exceed 1 ½ hours when concrete is transported in revolving drum truck bodies.

1.5 JOB CONDITIONS

- A. Environmental Requirements
 - 1. Do not place concrete during rain, sleet or snow unless adequate protection is provided and ENGINEER's approval is obtained.
 - 2. Do not allow rain-water to increase mixing water or damage surface finish.
- B. Cold Weather Concreting
 - 1. Conform to ACI 306, "Recommended Practice for Cold Weather Concreting."
 - 2. Temperature of concrete when placed shall not be less than following:

Air Temp.	Minimum Concrete Temp. (°F).	
	Sections with least dimension Under 12"	12" and Over
30 to 45	60	50
0 to 30	65	55
Below 0	70	60

3. When placed, heated concrete shall not be warmer than 80 F.
 4. Prior to placing concrete, all ice, snow, surface and subsurface frost shall be removed, and temperature of surfaces to be in contact with new concrete shall be raised to temperature specified for placing.
 5. Protect concrete from freezing during specified curing period.
 6. Heated enclosures shall be strong and windproof to insure adequate protection of corners, edges and thin sections.
 7. Do not permit heating units to locally heat or dry concrete.
 8. Do not use combustion heaters during first 24 hours unless concrete is protected from exposure to exhaust gases which contain carbon dioxide.
 9. Refer to ACI 306 for further requirements.
- C. Hot Weather Concreting - Conform to ACI 305, "Recommended Practice for Hot Weather Concreting".
1. Take precautions when ambient air temperature is 80 degrees F or above.
 2. Temperature of concrete when placed shall not exceed 85 degrees F.
 3. Cool forms and reinforcing to a maximum of 90 degrees F by spraying with water prior to placing concrete.
 4. Do not use cement which has reached a temperature of 170 degrees F or more.
 5. Prevent plastic shrinkage cracking due to rapid evaporation of moisture.
 6. Do not place concrete when evaporation rate (actual or anticipated) equals or exceeds 0.20 pounds per square foot per hour, as determined by Figure 2.1.4 of ACI 305.
 7. Set-retarding and water-reducing admixtures may be used with ENGINEER's approval when ambient air temperature is 90 degree F. or above to offset accelerating effects of high temperatures.
 8. Refer to ACI 305 for further requirements.
- D. Construction Joints
1. Divide wall pours into sections by construction joints (including contraction and expansion joints).
 2. If all construction joints are not shown on Drawings, limit all concrete pours as follows:
 - a. Limit wall pours to a maximum length of 60 feet.
 - b. Do not end wall pours at a corner.
 - c. Vertical wall construction joints shall be at least one-half the wall height in each direction from any corner.
 - d. Pour slab and beam arrangements monolithic.
 - e. Request for change in location of construction joints shown or called for, or the addition of such joints, shall be made by CONTRACTOR to ENGINEER before detailed

reinforcing drawings have been prepared by the steel fabricators.

3. Contraction and expansion joints as shown, detailed or called for on the Drawings.
- E. CONTRACTOR is solely responsible for the proper size and location of anchors, chases, recesses, openings, and embedded items required for the Work.

PART 2 – PRODUCTS

2.1 CONCRETE MATERIALS

- A. Cement: ASTM 150, Type II.
- B. Aggregates
 1. Fine aggregate - ASTM C33.
 2. Course aggregate - ASTM C33 except that air-cooled blast furnace slag will not be allowed.
 - a. Nominal maximum size of coarse aggregate shall not be larger than:
 - 1) 1/5 narrowest dimension between sides of forms, nor
 - 2) 3/4 inch minimum clear spacing between reinforcing bars, bundles or bars, minimum cover on form work for columns, beams, girders and walls.
 3. Aggregate for exposed aggregate surfacing.
 - a. 3/8" to 1/2" washed river gravel, free of silt, clay, organic material and salt.
- C. Water
 1. Clean, fresh and free from injurious amounts of oils, acids, alkalis, salts, organic materials, or other substances that may be deleterious to concrete reinforcement.
- D. Admixtures
 1. Use only as specified or approved in writing by ENGINEER.
 2. Do not use admixtures which cause accelerated setting of cement.
 3. Calcium chloride is not permitted.
 4. Air-entraining Agent: ASTM C260.
 5. Water-Reducing & Retarding: ASTM C494, Type D.
 6. Water Reducing: ASTM C494, Type A.
 7. Fly Ash: ASTM C618, Class F, with less than 5 percent ignition loss. Use less than 15 percent of cement quantity based upon 1.5 pounds of fly ash for each pound of cement reduction.

2.2 CONCRETE PRODUCTION

- A. Ready-Mixed Concrete
 - 1. Mixed and delivered, ASTM C94.

- B. Batching and Mixing Equipment
 - 1. "Recommended Practice for Measuring, Mixing, Transporting and Placing Concrete", ACI 304.

- C. Concrete Classes
 - 1. Class A.
 - a. 4500 psi structural concrete mix.
 - b. To be used in all areas of the project (headworks process building, water retaining basins, and UV structure.) except as described for Class B.
 - c. Class A can be substituted for Class B if simplicity of pour dictates.
 - 2. Lean Concrete
 - a. Non-structural concrete mix
 - b. To be used for structure backfill

- D. Proportioning
 - 1. Proportion ingredients for Class A and Lean Concrete to produce a well-graded mix of high density and maximum workability consistent with approved mix designs as follows:

	<u>Class A</u>	<u>Lean</u>
a. Minimum 28- day Compressive Strength (psi):	4500	n.a.
b. Avg. 28-day strength if Production Plant does not have 30 consecutive strength tests for concrete proportions:	5200	n.a.
c. Minimum cement content:		
Cement bag/cubic yard:	7	0.5
Pounds/cubic yard:	615-660	50
d. Maximum water/cement ratio:		
-air entrained:	0.45	n.a.
e. Fine to total aggregate ratio:		
-3/4 inch coarse:	0.35-0.36	0.52
-larger than 3/4 inch:	0.35-0.36	-
 - 2. Entrained Air
 - a. Minimum for all structural concrete exposed to elements including all watertight structures containing water, $6\frac{1}{2}\pm 1\frac{1}{2}$ percent.
 - 3. Slump
 - a. Keep as low as possible consistent with proper handling and thorough compaction.

- b. Shall not exceed 5 inches for Class A and B and 2 inches for concrete fillet of Class C mix.
 - c. A tolerance of 1 inch above maximum will be allowed provided average for all batches or most recent 10 batches, whichever is fewer, does not exceed the maximum.
4. Mixing - Minimum time
- a. Central mixed concrete, 1 minute for mixer capacities of one cubic yard or less, plus 15 seconds for each cubic yard or fraction thereof of additional capacity.
 - b. Truck mixed concrete, 100 revolutions after introduction of all ingredients. Maximum 300 revolutions.
 - c. Do not place concrete until Resident has had the opportunity to check the load for air entrainment and slump requirements. He may exercise this right for any load he so chooses.
5. Temperature: Maximum of 85 degrees F.

2.3 CONCRETE ACCESSORY MATERIALS

- A. Curing Materials
- 1. Sheet material: ASTM C171.
 - 2. Liquid membrane: ASTM C309.
- B. Expansion Joint Filler. Shall comply with the following unless otherwise shown on Drawings.
- 1. Bituminous type: ASTM D994. (Preformed mastic)
 - 2. Cork type: ASTM D1752, Type 2 or 3.
 - 3. Fiber type: ASTM D1751.
 - 4. Sponge rubber type: ASTM D1752, Type I.
- C. Bond Break Material
- 1. Felt: ASTM D2475.
 - 2. Plastic: polyethylene sheet, Product Standard 17, 8 mil, use only where shown on Drawings.
- D. Joint Sealers
- 1. Shall comply with the following unless otherwise shown on Drawings:
 - a. Hot-poured elastic type: ASTM D1190.
 - b. Cold - application type: ASTM D1850.
 - c. Hydrostatic pressure resistant sealant: Sikaflex 427, or 405/406, or equal.
- E. Vapor Barrier Material.
- 1. Polyethylene sheet: 8 mil. thickness.
- F. Curing and Sealing Compounds.

1. Liquid membrane-forming: ASTM C309.
 2. Use Protex "Triple Seal," Castle Chemical Corp., "Klearseal," or equal.
- G. Water stops
1. Shall comply with the following unless otherwise shown on Drawings:
 - a. Material:
 - 1) Polyvinyl chloride, (PVC); Corps of Engineers, CRD-C-572.
 - 2) Waterstop Rx, 3/4" x 3/4" Butyl Rubber and Bentonite waterstop as manufactured by America Colloid Company, with Primer.
 - b. Type.
 - 1) Construction joints: dumbbell.
 - 2) Expansion joints: ribbed with center bulb.
 - c. Size.
 - 1) Six (6) inches wide, minimum.
 - 2) 3/8 inch thick, minimum.

PART 3 – EXECUTION

3.1 INSPECTION

- A. General.
1. Assure that excavations and form work are completed.
 2. Check that fill under slabs are of the type, depth and degree of compaction specified.
 3. Assure that dirt, mud, encrusted concrete, debris and excess water has been removed.
 4. Check that reinforcement is properly positioned and secured in place.
 5. Verify that expansion joint material, anchors, waterstops and other embedded items are secured in proper position. Waterstop Rx that has been wetted shall be removed and replaced with dry. Prime all concrete at waterstop Rx locations. Provide cut nails as necessary for secure installation.
 6. Verify that all required tests for pipes under slabs have been completed.
 7. Keyways are to be continuous and formed. No free hand keyways permitted.

3.2 PREPARATION

- A. General.
1. Remove any hardened concrete and foreign material from inner surface of conveying equipment.

2. Prepare slab subgrades in accordance with ACI 301, Chapter 11.
 3. Moisten subgrade prior to placement, but do not cause water to pond, nor muddy or soft spots to appear.
 4. Provide vapor barrier material under all floor slabs on grade. Lap edges and ends 4 inches and seal with 2 inch pressure-sensitive tape. Seal edges with pressure-sensitive tape at vertical surfaces.
 5. Designate limits of each placement and obtain ENGINEER's approval of entire installation prior to proceeding.
- B. Concrete placed against gravel or crushed stone.
1. Cover with 8 mil polyethylene film all surfaces that do not contain at least 25 percent material passing a No. 4 sieve to protect concrete from loss of water.
 2. Lap joints at least 4 inches.
- C. Concrete placed against rock.
1. Remove all loose pieces of rock.
 2. Clean exposed rock surface with high pressure water hosing followed by high air pressure hosing.
- D. Concrete placed against hardened or existing concrete.
1. Prior to placing fresh concrete against surface of hardened concrete, complete the following:
 - a. Roughen, air clean, and thoroughly wet hardened surface to sound concrete.
 - b. Remove all laitance, foreign substances (including curing compound), wash with clean water, and thoroughly wet hardened surface before placing fresh concrete.
 - c. If hardened concrete is in roughened condition, clean all loose material by high pressure water hosing in combination with stiff brooming.
 2. Omit coarse aggregate from mix when placing first batch or batches of fresh concrete against hardened horizontal concrete surfaces.
 - a. Cover hardened concrete with a mortar puddle to a depth of at least 2 inches at every point before continuing with normal mix of concrete.

3.3 PLACEMENT BASE SLABS/WALLS

- A. Placing sequence - To reduce the effect of shrinkage cracks, concrete for bottom and walls shall be placed as follows:
1. Slabs
 - a. Place outer thickened slab sections
 - b. Place inner sections alternately, first on one side and then on other side of previously poured sections.

- c. Schedule pours so that two adjacent sides of each section are free, except at closure.
 2. Walls.
 - a. Divide walls into sections by construction joints or expansion joints shown on Drawings or as noted in Joint Submittal.
 - b. Place section near center of each wall first.
 - c. Place sections alternately, first on one side and then on other side of previously place section.
 - d. Schedule pours so that one end of each section is free, except at closures.
 3. Do not place two abutting sections within 48 hours, unless otherwise authorized by ENGINEER.
 4. Changes in construction joint locations from that shown on Drawings must have ENGINEER's written approval.
- B. Conveying.
 1. Convey concrete from mixer to final position as rapidly as practicable without segregation or loss of material.
 2. Use only metal or metal lined chutes with maximum length of 20 feet, having a maximum slope of 1 vertical to 2 horizontal, and a minimum slope of 1 vertical to 3 horizontal.
 3. Provide a hopper at the end of long belt conveyors and chutes not meeting the requirements in 2 above.
 4. Conveying by pumping methods shall conform to ACI 304, Chapter 9.
 - a. Maximum loss of slump, 2 inches.
 - b. Do not pump concrete having a slump of less than 2 inches.
 - c. Do not use aluminum or aluminum alloy pipe to convey concrete.
- C. Depositing.
 1. Deposit concrete in a continuous operation until section is completed.
 2. Regulate rate of placement so concrete remains plastic and flows into position.
 3. In walls place concrete in approximately horizontal layers 18 inches maximum depth for liquid containing structures and 24 inches for all other structures.
 4. Each layer of concrete shall be plastic when covered with following layer.
 5. Provide vertical joints as necessary to comply with these requirements.
 6. Maximum height of concrete free fall, 4 feet.
 7. Use a tremie for placing concrete in drilled piers and walls to prevent free fall of more than 4 feet. Do not allow concrete to

fall on reinforcement or other objects that would cause segregation.

8. Tremies shall have varying lengths to limit free fall of concrete to 4 feet at all times.
9. Place and compact concrete in wall or column forms before any reinforcing steel is placed in the system to be supported by such wall or column.
10. Do not exceed 6 feet of vertical height for any portion of wall or column placed monolithically with floor or roof slabs.
11. Concrete in walls or columns shall settle at least 2 hours before concrete is placed in structural systems to be supported by such walls or piers.
12. Allow concrete to thoroughly settle before top is finished.
 - a. Remove all laitance, debris, and surplus water from surfaces at tops of forms by screeding, scraping, or other effective means.
13. Overfill forms wherever top of a wall will be exposed and screed off excess concrete after settlement has occurred. Forms may be extended above top of wall by 2 feet provided work conforms to the requirements of the preceding paragraph 12.
14. No concrete shall be placed in water except with the written permission of the ENGINEER.

D. Consolidation.

1. During and immediately after placement, thoroughly vibrate and work around all reinforcements, embedments, and corners of forms, as recommended by ACI 309.
2. Use mechanical vibrators that will maintain at least 9000 cycles per minute when immersed in concrete.
3. Minimum horsepower per vibrator shall be 1 1/2.
4. Number and type of vibrators shall be acceptable to ENGINEER.
5. Do not use vibrators to transport concrete laterally in forms.
6. Vertically insert vibrators at points approximately 18 inches apart and to a depth to penetrate 6 inches into the preceding layer.
7. Vibrate each location for a length of time to obtain adequate consolidation (generally 5 to 15 seconds).

3.4 JOINTS

A. Watertight joints.

1. Provide waterstops at locations shown on Drawings.
2. Provide waterstops in wall and slabs that form a part of an interior room or dry pit which will be in contact with earth or liquid.

B. Expansion and contraction joints.

1. At all locations shown on Drawings and at all construction joints for water containing basins.

2. Do not extend reinforcement continuously through joint unless specifically shown on Drawings.
 3. Form joint with felt, ASTM D2475, extending full depth, where "break bond" or "isolation" joint is indicated.
 4. Use sponge rubber type filler where in contact with liquid.
 5. Provide expansion joints where walks abut structures.
- C. Construction joints.
1. Where shown on Drawings.
 2. Obtain ENGINEER's approval for location of construction joints not shown on Drawings.
 3. Locate joints as follows:
 - a. Columns and walls.
 - 1) At underside of beams, girders, haunches, drop panels.
 - 2) Column bases will not be required to be monolithic with floor beneath.
 - b. Beams and girders.
 - 1) Construction joints will not be allowed.
 - c. Suspended slabs.
 - 1) At or near center of span in flat slab or T-beam construction or centered over wall.
 - 2) No joint will be permitted between a slab and a concrete beam or girder unless specifically shown on Drawings.
 - d. Construction joints in walls and slabs shall be perpendicular to planes of their surfaces.
 4. If all construction joints are not shown on Drawings, limit all concrete pours as follows:
 - a. Limit wall pours to a maximum length of 60 feet.
 - b. Do not end wall pours at a corner.
 - c. Vertical wall construction joint shall be at least one-half the wall height in each direction from any corner.
 - d. Request for change in location of construction joints shown, or the addition of such joints, shall be made by CONTRACTOR to ENGINEER before detailed reinforcing drawings have been prepared by the steel fabricators.

3.5 EMBEDDED ITEMS

- A. Refer to Section 03100-Concrete Formwork.
- B. Waterstops.
1. Place in construction and expansion joints as indicated on Drawings.
 2. Waterstops shall be continuous in each joint.
 - a. Splice as recommended by manufacturer.
 - b. Splices shall be watertight.

- c. Thoroughly clean water stops of foreign material before splicing or placing concrete.
 - d. Splices shall be neat with the ends of the joined materials in true alignment.
3. Install with an approximately equal width of material embedded in concrete on each side of the joint.
 4. Provide suitable guards to protect exposed projecting edges and ends of partially embedded water stops for mechanical damage when concrete placement has been discontinued.
 5. Carefully place and vibrate concrete around water stops to ensure the following: maximum concrete imperviousness and density, the complete filling of the forms in the vicinity of the waterstop, and complete contact between the concrete and all surfaces of the waterstop.
 6. Make adequate provision to support and completely protect the waterstops in proper position during the progress of the Work and take particular care for their protection during form removal. Water stops shall be wired to reinforcing when possible to maintain alignment.
 7. Replace or repair punctured or otherwise damaged waterstops.
 8. Waterstops are to be in center of keyway unless detailed otherwise.

3.6 FINISHING EXPOSED SURFACES

- A. Finishing unformed surfaces.
 1. Slabs, floors, stairs, pavements, sidewalks, driveways, curb and gutters, and similar structures.
 - a. Provide surface conforming to proper elevation and contour with all aggregates completely embedded in mortar by screening.
 - 1) Screened surfaces shall be free of surface irregularities.
 - 2) Maximum variation from level in any 10 feet section, $\pm 1/4$ inch.
 - b. Provide an initial float finish as soon as concrete has stiffened sufficiently for proper working.
 - 1) Remove any piece of coarse aggregate which is disturbed by float or which causes a surface irregularity and replace with mortar.
 - 2) Produce a surface of uniform texture and appearance with initial floating, without unnecessary working of surface.
 - c. Provide a second floating at time of initial set.
 - 1) Produce a finish of uniform texture and color with second floating.

- 2) Float finish produced by second floating shall be completed finish unless additional finishing is specifically required and specified.
- 3) Perform floating with hand floats or suitable mechanical compactor-floats.
- d. Follow second floating with a broomed treatment to surface to provide a uniform abrasive texture of constant color, in areas where concrete is to remain exposed.
 - 1) Broom at right angles to normal traffic direction.
 - 2) Broom exterior concrete stairs, sidewalks, driveways, curb and gutters, pavements and exterior decks and slabs.

B. Troweling.

- 1. Steel trowel finish following surfaces:
 - a. Exposed interior floor surfaces after construction is completed.
 - b. Surfaces to be covered with resilient floor covering or thinset terrazzo.
 - c. Exposed portion of top of equipment bases.
 - d. Top of interior curbs.
 - e. Other surfaces that may be designated on Drawings.
 - f. Steel trowel finish will not be required for slabs normally submerged.
 - g. Headworks Slabs
 - h. Chemical storage areas and basins
- 2. Perform steel troweling after second floating when surface has hardened sufficiently to prevent excess of fines being drawn to surface.
 - a. Produce a dense, smooth, uniform surface free from blemishes and trowel marks.
 - b. Power or hand steel trowel surface to smooth finish with a tolerance of $\pm 1/4$ inch in 10 feet.
 - c. Hand trowel areas inaccessible to power trowel.

C. Finishing surfaces for bonding.

- 1. Float finish all surfaces to be covered with concrete topping.
- 2. Remove by brushing or air blasting at time of initial set, all laitance, surface mortar, and unsound material.
- 3. Surfaces shall be rough, clean, and sound.

- D. Edging.
 - 1. Edge exposed edges of floated or troweled surfaces with a tool having 1/4 inch corner radius, unless these edges are specified to be beveled.

3.7 CURING

- A. General.
 - 1. Keep concrete continuously moist for at least 7 days after placement by use of:
 - a. Ponding or continuous sprinkling.
 - 1) Begin as quickly as possible after initial set.
 - 2) Provide complete coverage with minimum of runoff by regulating rate of water application.
 - 3) Interrupt application of water to wall for grout cleaning only over areas being cleaned.
 - 4) Do not permit wall areas to become dry which are not being grout cleaned.
 - b. Wet burlap, wet absorptive mats, wet sand, polyethylene sheeting, or membrane curing compound.
- B. Membrane curing compound.
 - 1. May be used in lieu of water curing on concrete which will not be covered later with topping, mortars, additional concrete, paint, or adhesive attached flooring.
 - 2. Spray apply at coverage recommended by manufacturer.
 - 3. Cover unformed surfaces with curing compound within 30 minutes after final finishing.
 - 4. Apply curing compound immediately to formed surfaces if forms are removed before end of specified curing period.
 - 5. Protect compound against abrasion during curing period.
- C. Film Curing.
 - 1. Film curing with polyethylene sheeting may be used in lieu of water curing on concrete which will be covered later with mortar or additional concrete, or will otherwise be covered or hidden from view.
 - 2. Begin as quickly as possible after initial set of concrete.
 - 3. Cover surfaces completely with polyethylene sheeting.
 - 4. Overlap edges for proper sealing and anchorage.
 - 5. Seal joints between sheets.
 - 6. Promptly repair all tears, holes and other damage.
 - 7. Anchor continuously all edges and anchor surface as necessary to prevent billowing.

3.8 FINISHING FORMED SURFACES

- A. Repair of defective concrete.

1. Repair, to satisfaction of ENGINEER, within 24 hours after removal of forms, all defects in concrete surfaces.
 2. Replace, to satisfaction of ENGINEER, within 48 hours after adjacent forms have been removed, all defective concrete.
 3. Cut out and remove to sound concrete, with edges square cut to avoid feathering, all honeycombed or otherwise defective concrete.
 4. Repair work shall conform to Chapter 9, ACI 301.
 5. Perform in a manner that will not interfere with thorough curing of surrounding concrete.
 6. Adequately cure all repair work.
- B. Finishing.
1. Rough form finish - All concrete surfaces not exposed to view and in contact with earth from 1 foot below finish grade. Finish is accomplished by the following:
 - a. Remove all fins and other surface projections when damp proofing is specified.
 - b. Provide a flush surface and use a power grinder, if necessary, to remove fins and projections.
 - c. Fill all tie holes with patching mortar.
 - d. Tar contraction cracks, construction joints and tie holes below finish grade on the side exposed to earth if inside is a dry room.
 2. Smooth form finish - Use smooth form on all surfaces except rough form areas described above. Finish to be accomplished by the following:
 - a. Use form facing to produce a smooth, hard, uniform surface.
 - b. Keep number of seams to a minimum.
 - c. Remove all fins and projections.
 - d. Clean, wet, and fill all tie holes with patching mortar.
 - e. Repair and patch all defects including honeycombs.
 3. Smooth form finish can be substituted for rough form.
 4. Basin floors.
 - a. Accurately finish to a uniformly slope.
 - b. Conform to ACI Committee 117 tolerance $F_f \leq 25$ (approximate variation from level in any 10 foot section, $\pm 1/4"$).
 5. Floor sealer.
 - a. Provide two coats of clear floor sealer in addition to any membrane curing compound to all floors subject to foot traffic and which are not required to be covered with any type of final floor covering.
 - b. Apply first coat at end of curing period and before any traffic is permitted.
 - c. Apply second coat after floor has been cleaned in preparation for final inspection.

- d. Apply in strict accordance with manufacturer's recommendations.

3.9 QUALITY CONTROL

A. Concrete tests.

- 1. Shall be in accordance with requirements of ACI 301, Chapter 16 - Testing, except as noted or modified in this Section.

- a. Strength test.

- 1) Mold and cure three cylinders from each sample.
- 2) Test one at 7-days for information and two at 28-days for acceptance.

- b. Minimum samples.

- 1) Collect the following minimum samples for each 28-day strength concrete used in the Work for each days placing:

<u>Quantity</u>	<u>Number of Samples</u>
50 cubic yards or less	2
50 to 100 cubic yards	4
100 cubic yards or more	4 plus 1 sample for each additional 50 cubic yards

- c. Sample marking.

- 1) Mark or tag each sample of compression test cylinders with date and time of day cylinders were made.
- 2) Identify location in Work where concrete represented by cylinders was placed.
- 3) Identify delivery truck or batch number, air content, and slump.

- d. Slump test.

- 1) Conduct test for each strength test sample and whenever consistency of concrete appears to vary.

- e. Air content.

- 1) Conduct test from one of first three batches mixed each day and for each strength test sample.

B. Acceptance of concrete.

- 1. Strength level of concrete will be considered satisfactory so long as average of all sets of three consecutive strength test results equals or exceeds specified 28-day strength and no individual strength test result falls below specified strength by more than 500 psi.

C. Failure of test cylinder results.

1. Upon failure of test cylinder results, ENGINEER may require CONTRACTOR, at his expense, to obtain and test at least three 2-inch diameter cored samples from area in question.
 - a. Conform to ASTM C42.
 2. Concrete will be considered adequate if average of three cores is at least 85% of, and if no single core is less than 75% of specified 28-day strength.
 3. Upon failure of core test results, ENGINEER may require CONTRACTOR, at his expense, to perform load tests as specified in ACI 318, Chapter 20.
 4. Fill all core holes as specified for repairing defective concrete.
- D. Effluent Box Leakage Tests
1. Visible leaks shall be repaired by chemical grout or epoxy infection.
 2. CONTRACTOR shall submit products and procedures to the ENGINEER for acceptance prior to performing repair work.

END OF SECTION

SECTION 03360

CONTACT GROUTING

PART 1 - GENERAL

1.1 REQUIREMENT

- A. This section specifies minimum requirements for contact grouting of the annular space of casing pipe installed by microtunneling, pipe jacking, or pipe ramming in accordance with the reference specification sections.

1.2 REFERENCE SPECIFICATIONS, CODES, AND STANDARDS

- A. Comply with the applicable reference Specifications:
1. General Conditions
 2. Section 02316, Pipe Ramming
 3. Section 02440, Pipe Jacking
 4. Section 02445, Instrumentation and Monitoring
 5. Section 02623, Microtunneling
 6. Section 03610, Ground Pre-treatment
- B. Comply with the following industry standards effective at time of bid:
1. ASTM C31 - Standard Practice for Making and curing Concrete Test Specimens in the Field
 2. ASTM C39 - Standard Test Method for Compressive Strength of Cylindrical Concrete Specimens
 3. ASTM C109 - Standard Test Method for Compressive Strength of Hydraulic Cement Mortars (Using 2-inch Cube Specimens)
 4. ASTM C144 - Standard Specification for Aggregate for Masonry Mortar
 5. ASTM C150 - Standard Specification for Portland Cement
 6. ASTM C937 - Standard Specification for Grout Fluidifier for Preplaced-Aggregate Concrete
 7. NSF/ANSI Standard 060 - Drinking Water Treatment Chemicals – Health Effects

1.4 DEFINITIONS

- A. For definitions refer to Specification Sections 02623 and 03610.

1.5 DESIGN REQUIREMENTS

- A. If using a microtunnel boring machine (MTBM) outside diameter (OD) of 54 inches or larger, immediately and continuously after the completion of the drive, the Contractor shall perform contact grouting to fill the annular space along the entire pipe. Place contact grout where voids are anticipated or created.
- B. Grout mix (water-cement) ratios shall be expressed in cubic feet of water per cubic foot of cement (94 pound bag). The water-cement ratio by volume shall be varied as needed to fill the voids outside the jacking pipe. The range of water-cement ratios shall be between 1:1 and 0.75:1 by volume or as approved by the Engineer.
- C. Grout shall consist of Portland cement, not more than 2 percent bentonite by weight of cement, fluidizer as necessary, and water in the proportions specified herein or acceptable to the Engineer. Sand may be added to the grout mix in instances of very high grout takes as approved by the Engineer, but in no case shall the grout contain more than three parts sand to one part cement by weight. The addition of sand shall require additional fluidifier to be added to the grout mix.
- D. Provide grout with a minimum unconfined compressive strength (UCS) of 100 pounds per square inch (psi) in 24 hours, 500 psi in 7 days, and 1,000 psi in 28 days.
- E. Dispose of grout not injected after 90 minutes of mixing.

1.6 QUALITY ASSURANCE

- A. Calculations for work associated with contact grouting shall be made by a Professional Engineer registered in the State of Colorado. Experience of the engineer shall include three (3) projects within the last five (5) years performing similar grout pressure or hydrofracture calculations.
- B. Work Plan includes:
 - 1. Contact grouting methods and details of equipment, grouting procedures and sequences, monitoring and recording equipment, methods of controlling grout pressure, and provisions to protect pipe lining or shaft supports.
 - 2. Schedule for all grouting operations and associated works by reach. Schedule shall be coordinated with overall schedule for the Contract.
 - 3. Procedure for disposing of unused grout and flushing lines.
- C. Grout Strength Tests:
 - 1. Prepare and test samples for 24-hour, 7-day, and 28-day compressive strength tests according to ASTM C39 for cylinders or ASTM C109 for cubes, except as otherwise specified herein.
 - 2. Take grout for the cylinders or cubes from the nozzle of the grout injection line. Provide at least one set of four (4) samples for each 100 cubic feet of grout injected, but not less than one set for each batch in accordance with ASTM C31.
- D. Grouting Logs: Grouting locations, pressures, volumes, and grout mix pumped, time of

pumping, mixer person and person at grout port. Note any problems or unusual observations on logs.

1.7 CONTRACTORSUBMITTALS

- A. Submittals shall be made in accordance with General Conditions and as specified herein.
- B. Submittals shall be coordinated with all relevant submittals, assembled and submitted as a single, comprehensive submittal. See the comprehensive submittal requirement in Section 02623.
- C. Where calculations are required to be submitted, they shall be signed and sealed by a Professional Civil Engineer registered in the State of Colorado. Calculations shall clearly identify all parameters used, state all assumptions made in the calculation, and identify all sources of information.
- D. All shop drawings shall be legible with dimensions accurately shown and clearly marked in English.
- E. Qualifying Submittals:
 - 1. Qualifications of Contractor's Engineer.
 - 2. Work Plan.
 - 3. Product Data:
 - a. Materials specified in Part 2.
 - b. Material Safety Data Sheets.
 - 4. Certificate, dated with six months of use, from an independent laboratory that the calibration gauge is accurate to 1 psi.
- F. Pre-Construction Submittals:
 - 1. Details of grout mix proportions, admixtures, including manufacturer's literature, and laboratory test data verifying the strength and set time of the proposed grout mix.
 - 2. Calculations confirming planned injection pressures and maximum injection pressures at regular increments not to exceed 40 feet longitudinally. Detail these pressures and show how they will not exceed the overburden pressure (including hydrostatic pressure) to cause hydrofracturing of the ground. Pressure and the amount of grout shall be controlled by the Contractor to avoid pipe damage and displacement of the pipe and soil beyond specified tolerances.
 - 3. Grout/lubrication one-way valves assemblies.
 - 4. Grout/lubrication piping diagram and shop drawing at point of injection.
 - 5. Results of Grout Strength Tests for proposed mixes.
- G. Construction Submittals:

1. Daily Grouting Logs one work day after injection.
2. Cumulative Test reports for each break within one work day after break.

1.8 PROJECT/SITE CONDITIONS

- A. For subsurface ground information see Section 02623.

PART 2 - PRODUCTS

2.1 MATERIALS

- A. Cement: Cement shall be Type II or Type V Portland cement conforming to ASTM C150. Type II cement shall meet Table 4 false set requirements of ASTM C150.
- B. Bentonite: Bentonite shall be a commercially processed powdered bentonite, Wyoming type; NSF/ANSI Standard 060 compliant.
- C. Water: Potable.
- D. Sand: Conform to ASTM C144 except:
1. Fineness modulus: Between 1.50 and 2.00 and
 2. Grading Requirements:

Sieve Sizes	Percentage passing by Weight
No. 8	100
No. 16	95-100
No. 30	60-85
No. 50	20-50
No. 100	10-30
No. 200	0-5

- E. Fluidizer: Fluidizers, or fluidifiers, shall hold the solid constituents of the grout in colloidal suspension, be compatible with the cement and water used in the grouting work, and comply with the requirements of ASTM C937.
- F. Admixtures: Shall be accepted by the Engineer. If commercially available and acceptable to the product manufacturer all polymers, and additives, other than soda ash, shall be NSF/ANSI Standard 060 compliant.

2.2 EQUIPMENT

- A. Equipment for mixing and injecting grout shall be adequate to satisfactorily mix and agitate the grout and pump it into the annular space at a constant pressure at variable delivery volumes.
- B. Provide a pressure gauge at the grout pump and a pressure gauge at the grout port. Periodically check the accuracy of the gauges with an accurately calibrated pressure gauge. Provide a minimum of two spare pressure gauges available on site at all times.

- C. Provide a flow meter to determine the volume of grout injected. Calibrate the meter in cubic feet to the nearest one-tenth of a cubic foot.
- D. Provide grouting hoses with an inside diameter of not less than 1 ½ inches or not more than 2 inches and capable of withstanding twice the maximum water and grout pressures to be used.
- E. Provide injection system with a grout recirculation hose.
- F. Provide one-way grout injection or lubrication valves.
- G. Maintain the grouting equipment in satisfactory operating condition throughout the course of the work to ensure continuous and efficient performance during grouting operations.

PART 3 - EXECUTION

3.1 GENERAL REQUIREMENTS

- A. Perform all work in accordance with accepted submittals.
- B. Control the grout pressure so as to avoid damaging the jacking pipe, to avoid movement and damage to the surrounding ground or structures, and to avoid hydrofracture of the grout.
- C. Perform all grouting operations in the presence of the Engineer and provide the City with access to the grouting operations. Notify the Engineer at least one work day in advance of starting contact grouting operations.
- D. Maintain a copy of the Contract Documents at a location acceptable to the Engineer and accessible to the grout operator and the Engineer.
- E. Contractor shall take care to prevent the spill or escape of grout to the ground surface, into any water body, or into another underground facility. The Contractor shall closely monitor grouting operations to detect any spills or escape of grout to the surface, into any water body, or into another underground facility. Any such spill shall be immediately contained and cleaned-up.
- F. During grouting work, provide for adequate disposal of all waste and wastewater. Remove and properly dispose of all waste grout resulting from grouting operations. The contents of grout lines shall only be discharged into an appropriate container located on the surface.

3.2 MIXING AND INJECTION OF GROUT

- A. Provide materials free of lumps when added to the mixer.
- B. Agitate the grout mix continuously.
- C. Grout shall flow unimpeded and shall completely fill all of the annular space and voids.

- D. Make a hookup to every grout port.
- E. Dispose of unused grout and flushed grout in accordance with established procedures.
- F. Re-circulate grout mixes when any new mix is batched or after adding water, fluidizer, or sand to the mix. Re-circulate the mix for at least 2 minutes prior to pumping grout into the grout ports.
- G. Progress with grouting sequentially in a constant up-gradient direction.
- H. Grouting in any single port shall be considered completed when less than 1.0 cubic foot of grout, of the accepted mix and consistency, is pumped in 5 minutes under the submitted maximum injection pressure or the grout flows through the next grout port, or shaft at the same rate as the rate of pumping.

3.3 CLEANUP

- A. After completion of the contact grouting, the grout ports shall be plugged and the interior of the pipe finished to a smooth, even surface and watertight condition.
- B. Grind any material from inside casing that may impinge on carrier pipe insertion.
- C. Clean grout and any deleterious material from inside the jacking pipe.
- D. Remove and properly dispose of all waste materials.

END OF SECTION

PART 1 - GENERAL

1.1 DESCRIPTION

- A. This Section covers sand-cement grout, nonshrink-nonmetallic grout, grout epoxy, bonding agent epoxy, and where each is to be used. Grout for trenchless work is found in Section 03360.
- B. Grouting is required for the following, but is not necessarily limited to the items listed.
1. Pump, motor, and equipment baseplates, pedestals, or bedplates
 2. Column baseplates
 3. Motor control center bases
 4. Other miscellaneous baseplates
 5. Grouted cells in concrete masonry walls if not specified otherwise under masonry sections of these Specifications
 6. Stop gate keyouts
 7. Slide gate frames
 8. Anchor bolts
 9. Reinforcing bars in existing hardened concrete
 10. Watertight structures where walls join tank bottoms or hardened concrete floors
 11. Openings in cast-in-place or precast concrete sections where cast-in-place walls are constructed around openings
 12. Open or closed channel fillets
 13. Fillets required for equipment installed
 14. Structural floors when called for on Drawings
 15. Grout inside joints of 48" RCP
 16. Other grout uses as shown or called for on Drawings

1.2 SUBMITTALS

- A. Submit complete Shop Drawings on premixed grout products in accordance with Section 01340.

PART 2 - PRODUCTS

2.1 MATERIALS

- A. Grout, Sand-Cement: 2 inches or more in thickness
1. Portland cement: ASTM C150, Type IIA
 2. Fine aggregate: ASTM C33, clean, well-graded natural sand
 3. Coarse aggregate: ASTM C33, 90 percent passing ½ inch sieve, 90 percent retained on a No. 3 sieve

4. Ratio of fine and coarse aggregate: 50 percent of each by volume.
 5. Water: clean and free from deleterious substances
- B. Grout, Sand-Cement: less than 2 inches in thickness
1. Portland cement: ASTM C150, Type IIA
 2. Fine aggregate: ASTM C33, clean, well-graded natural sand
 3. Water: clean and free from deleterious substances
- C. Grout, Nonshrink-Nonmetallic: Compounds must conform to CRD-C-621
1. Furnish products factory premixed and requiring only the addition of water
 2. Master Builders, "Masterflow 713 Grout"
 3. Sika Corp., Sikagrout 212
 4. L&M Construction Chemicals "Crystex"
 5. Sonneborn-Contech, "Sonogrout"
 6. Water: clean and free from deleterious substances.
- D. Epoxy Grout
1. Manufacturers
 2. Sika Chemical Corporation, Sikadur 32, HiMod
 3. The Euclid Chemical Company, designed specifically for this purpose
 4. L&M Construction Chemicals "Epogrout"
- E. Adhesive Anchor
1. Hilti RE 500-SD
 2. Simpson ET-HP
 3. Sika AnchorFix-3001
- F. Epoxy Bonding Agent
1. Manufacturer
 2. Sika Chemical Corporation, Sikadur 32; Hi-Mod
 3. The Euclid Chemical Company, designed specifically for this purpose
 4. L&M Construction Chemicals "Epobond"

PART 3 - EXECUTION

3.1 PREPARATION

- A. Grout, Sand-Cement: 2 inches or more in thickness
1. Mix: One part Portland cement, 2½ parts of aggregate (50 percent fine and 50 percent coarse) by volume, with sufficient water for placement and hydration.
 2. Mix grout in a mechanical mixer.
 3. Use as little water as possible for steep grout fillets.

4. Saturate concrete to receive grout with clean water for 24 hours prior to grouting.
- B. Grout, Sand-Cement: less than 2 inches in thickness
1. Mix: One part Portland cement, 2½ parts of fine aggregate by volume, with sufficient water for placement and hydration.
 2. Mix grout in a mechanical mixer.
 3. Use no more water than is necessary to produce a flowable grout.
 4. Saturate concrete to receive grout with clean water for 24 hours prior to grouting.
- C. Grout, Nonshrink-Nonmetallic
1. Mix and place in strict accordance with directions and instructions of manufacturer.
 2. Fill spaces and cavities below top of baseplates, bedplates, column baseplates, and other areas requiring grouting.
 3. Leave no voids.
 4. Provide forms where structural components of baseplates or bedplates will not confine grout.
- D. Grout, Epoxy and Bonding Agent, Epoxy.
1. Mix and place in strict accordance with recommendations and instructions of manufacturer.

3.2 LOCATIONS OF USE

- A. Where type of grout is not designed on Drawings, the following schedule will apply.
- B. Grout, Sand-Cement as listed in 2.1.A or 2.1.B
1. Openings in cast-in-place or precast concrete sections when short cast-in-place walls or curbs are constructed around openings.
 2. Open or closed channel fillets.
 3. Similar fillets before, after or within certain equipment pieces.
 4. Motor control center bases if not poured prior to motor control centers being in final position.
 5. Bottom structural floors of water containing structures.
 6. Other grout locations called for on Drawings and where nonshrink-nonmetallic or epoxy grout is not necessary.
- C. Grout, Nonshrink-Nonmetallic
1. Pump, motor, and equipment baseplates, pedestals or bedplates.
 2. Stop plate keyouts.
 3. Sluice gate and slide gate frames.
 4. Anchor bolts.
 5. Patching of spalled concrete, floors and walls.
 6. Pipe penetrations

7. Stop plate keyouts.
 8. Column baseplates.
 9. Other items or areas requiring nonshrink, nonmetallic grout.
- D. Grout, Epoxy
1. Use when setting reinforcing rods into existing hardened concrete.
 2. Bonding Agent, Epoxy
 3. Use when pouring fresh concrete against existing hardened concrete.

3.3 FINISHING AND CURING

- A. Edge Finishing
1. Finish smooth edges exposed to view after grout has reached initial set.
 2. Cut edges flush at baseplate, bedplate, or piece of equipment, except where shown to be finished on a slope.
- B. Curing
1. Protect against rapid loss of moisture by covering with rags kept wet or polyethylene sheets.
 2. Wet cure for at least 7 days after edge finishing is completed.
 3. Coat with manufacturer recommended curing agent.
- C. Follow manufacturer's recommendations where applicable.

END OF SECTION

SECTION 03610

GROUND PRE-TREATMENT

PART 1 - GENERAL

1.1 REQUIREMENTS

- A. The Work specified in this Section consists of all operations necessary or incidental to providing ground pre-treatment for:
 - 1. Shaft construction as specified in Section 02621.
 - 2. The launch and reception of the trenchless construction equipment.
 - 3. Any other location the Contractor uses ground improvement.
- B. The Contractor shall select one or a combination of the following methods to meet the design and performance criteria for ground pre-treatment specified in these specifications:
 - 1. Cement Permeation Grouting
 - 2. Solution Permeation Grouting
 - 3. Grouting and other soil-cement mixing methods
- C. Ground pre-treatment is deemed specialty work. The Contractor performing ground pre-treatment shall have experience as specified herein.
- D. The Work specified in this Section consists of the requirement to mitigate adverse behaviors including raveling, running and flowing ground and where groundwater is anticipated.

1.2 REFERENCE SPECIFICATIONS, CODES, AND STANDARDS

- A. Comply with the applicable reference Specifications:
 - 1. General Conditions
 - 2. Section 02316, Pipe Ramming
 - 3. Section 02440, Pipe Jacking
 - 4. Section 02445, Instrumentation and Monitoring
 - 5. Section 02621, Shaft Construction
 - 6. Section 02623, Microtunneling
- B. Comply with the following industry standards effective at time of bid:

1. ASTM C39, Test Method for Compressive Strength of Cylindrical Concrete Specimens.
2. ASTM C150, Specification for Portland Cement.
3. ASTM C618, Specification for Fly Ash and Raw or Calcined Natural Pozzolan for Use as a Mineral Admixture for Portland Cement Concrete.
4. ASTM D4219, Unconfined Compressive Strength Index of Chemically Grouted Soils.
5. ASTM E329, Standard Specification for Agencies Engaged in Construction Inspection, Testing, or Special Inspection
6. NSF/ANSI Standard 060, Drinking Water Treatment Chemicals – Health Effects

1.3 DEFINITIONS

- A. For additional definitions refer to Section 02316, 02440, and 02623.
- B. Additives (admixtures): Any natural or chemical product added to the grout mix in order to reduce bleed water, modify viscosity and cohesion, and enhance the properties of rheology to permeate in situ.
- C. Chemical Grout: Chemical grouts are injected into voids as a solution. Chemical grouts react after a predetermined time to form a solid, semisolid, or gel.
- D. Grout Header: The manifold located at the point of injection, consisting of valves, gauges, pipes and hoses required to regulate the rate of flow, pressure and volume, of grout being injected into each hole.
- E. Grout Mix: Grout materials consisting of either a cement slurry or an ultrafine cement slurry to which additives such as fly ash, blast furnace slag, viscosity modifying agents, and superplasticizers may be incorporated, resulting in a stable grout; and chemical grout consisting of urethane, acrylic, or sodium silica grout mortar.
- F. Permeation Grouting: Permeation grouting consists of filling the voids in a matrix material with grout slurry, displacing any water present in the void space. To prevent unwanted fracturing of the matrix, the grout is injected at a pressure less than the ground overburden pressure.
- G. Water-Cement Ratio (Cement Slurries): The volumetric proportion in the grout mix of the water and loose cement plus any additive to be included. As weight batching shall generally be used, water-cement ratios shall be reported both as volume ratios and weight ratios.

1.4 DESIGN REQUIREMENTS

- A. The work required herein relies substantially on the Contractor's responsible means and methods for performing ground pre-treatment.

1.5 PERFORMANCE REQUIREMENTS

- A. Provide complete coverage at shafts and tunnels to satisfy the following requirements:
 - 1. Stabilize ground at the entrance and exit seals and to the extent that no ground enters the shaft during launch and reception, groundwater inflows as specified in Section 02621, and ground settlement directly above the tunnel does not exceed that specified in Section 02445.

1.6 QUALITY ASSURANCE

- A. Requirements outlined below shall be met at the time of bid and remain in force through completion of the project. Subcontracted work does not qualify as experience.
 - 1. Grouting Contractor shall demonstrate the following relevant experience: Three (3) projects completed successfully within the last five (5) years similar in scope and purpose to the Work specified herein.
 - 2. Grouting Superintendent. The Contractor's field staff to include minimum one ground improvement superintendent for each shift during which grouting operations are taking place. The Grouting Superintendent shall have a minimum of five (5) years combined field experience in a similar position.
 - a. Grouting Superintendent shall be present on site full time during grouting
 - 3. Grouting Engineer: The Contractor's full-time field staff to include minimum one ground improvement engineer with at least seven (7) years of related experience in the design and field application of grouting technology similar to that required for this project.
 - a. The Grouting Engineer shall have a valid license as a Civil Engineer in the State of Colorado.
 - b. If performing grouting on more than one shift per day, the Grouting Engineer must be on-site for at least one of the grouting shifts and be on-call for other daily grouting shifts.
- B. Ground Pre-Treatment Program and Procedures: Provide work plan including:
 - 1. Means and methods for performing ground pre-treatment at each area requiring pre-treatment. Identify staging areas, patterns, orientations, sequences, and depths. Identify types of grout pipes and packers for cement

- and solution permeation grouting. Identify depth and width of grout columns for grouting operations.
2. Description of planned mix proportions.
 3. Calculations including computations of grout quantities with respect to porosity, strength of the grouted mass, target volumes, reduction in permeability, and refusal criteria. The shaft designer must approve the design and construction of the added loads during the ground pre-treatment operations.
 4. Description of and specifications for proposed drilling, grout mixing, and grout injection equipment including layout and sizes of grout lines.
 5. Manufacturer cut sheets for valves and gages to be used including documentation that gages have been calibrated for the project.
 6. Certification of calibration of pressure gauges and flow meters.
 7. Proposed time schedule, work hours, and crew size for performing ground pre-treatment.
 8. Traffic control plans if needed, including sequencing and duration of detours and lane closures, as specified elsewhere in these specifications.
- C. Survey Control: Provide qualified survey personnel in accordance with the General Conditions.
- D. Quality Control Plan including:
1. Method for assuring that each grout location has been fully grouted and that the strength and permeability requirements have been achieved. Confirmatory methods shall include evidence of past satisfactory use under similar circumstances.
 2. Method for assuring that ground improvement does not damage other subsurface features and installed geotechnical instrumentation.
 3. Testing performed by an independent testing agency, which can certify compliance with the requirements of ASTM E329, or as accepted by the Engineer. The laboratory shall be able to demonstrate a minimum of five (5) years of experience performing the laboratory tests required herein.
 4. Sample Grouting Daily Shift Report: Date, start and finish times, shift and foreman's name, hole location, hole length, measured water inflow, mix type (including ratios of cement, water, and additives), gel time, grout flow rates, grout pressures, grout quantities injected, refusal criteria and acceptance, and observations for each injection point.

5. Method for assuring that ground improvement and ground improvement equipment does not adversely affect the trenchless construction operation.
6. Contingency plans for:
 - a. Abandoned holes.
 - b. Holes out of vertical tolerance.
 - c. Adjacent columns fail to structurally connect and perform as specified herein.

1.7 CONTRACTORSUBMITTALS

- A. Submittals shall be made in accordance with the General Conditions and as specified herein.
- B. Submittals shall be coordinated with all relevant submittals, assembled and submitted as a single, comprehensive submittal. See the comprehensive submittal requirement in Section 02623.
- C. Where calculations are required to be submitted, they shall be signed and sealed by a Professional Civil Engineer registered in the State of Colorado. Calculations shall clearly identify all parameters used, state all assumptions made in the calculation, and identify all sources of information.
- D. All shop drawings shall be legible with dimensions accurately shown and clearly marked in English.
- E. Qualifying submittals:
 1. Qualifications of Grouting Contractor, Grouting Superintendent, and Grouting Engineer.
 2. Product Data
 - a. Materials specified in Part 2.
 - b. Material Safety Data Sheets.
 - c. Manufacturer's mixing and handling requirements, personal safety equipment, first aid measures, and methods for proper storage and disposal of waste materials, including containers.
 3. Certifications
 - a. Certified laboratory test results at least 30 days before starting ground improvement operations documenting that the proposed grout mix meets specified requirements of three sets of three grouted laboratory samples.

- b. Products described herein including Certificates of Compliance from the manufacturer.
 - c. Manufacturer's certificate of origin for sodium silicate.
 - d. Personnel trained in handling, mixing, injection, and disposal of materials.
 4. Quality Control Plan.
- F. At least 30 days before beginning grouting work submit the proposed Ground Pre- Treatment Program and Procedures.
- G. Prior to commencement of grouting works, submit the following:
 1. Final working shop drawings showing hole layout and extent of grouting envelope.
 2. Description of proposed stage grouting sequence, table of target injection volumes, injection pressures, grout materials, mix proportions, and procedure for altering mix proportions based on observed grout take.
 3. Provide site specific details, including number and layout of grout holes, orientation of holes, types or depth of grout, graphical grout-take logs, injection pressures, water pressure injection tests, and other relevant data depending on the application and the grout type.
- H. Construction submittals:
 1. Within 24 hours of any ground pre-treatment, provide location (station) and details of such application, including number and layout of grout holes, orientation of holes, types or depth of grout, graphical grout-take logs, injection pressures, water pressure injection tests, and other relevant data depending on the application and the grout type.
 2. Daily grouting shift reports.
 3. Written notifications:
 - a. 10 work days advance notice of performing ground improvement at any site.
 - b. Immediately of leakage during ground improvement operations.
 4. Laboratory test results:
 - a. Results within one work day following test

- b. Cumulative reports within 5 work days following last test.

1.9 DELIVERY, STORAGE AND HANDLING

- A. Transport and store materials as prescribed by the manufacturers of these materials, as detailed in the data provided by the manufacturers. Protect material from mechanical damage and damage caused by environmental exposure. Do not use materials beyond expiration date.
- B. Deliver sodium silicate in sealed containers or a certified tank truck, and accompanied by the supplier's certificate of origin. Deliver reactant materials in sealed containers accompanied by the supplier's certificate of origin.
- C. Store chemicals in metal tanks, suitably protected from accidental discharge.
- D. Materials to be handled by trained personnel.

1.10 PROJECT/SITE CONDITIONS

- A. For Subsurface Ground Information see Section 02621 and Section 02623.

PART 2 - PRODUCTS

2.1 MATERIALS

- A. Cement Grout
 - 1. Cement – ASTM C150, Type II or III, or microfine cement.
 - 2. Bentonite – High yield sodium bentonite; NSF/ANSI Standard 060 compliant.
 - 3. Pozzolan – ASTM C618, Type F.
 - 4. Water – Potable.
 - 5. Admixtures – Shall be accepted by the ENGINEER. If commercially available and acceptable to the product manufacturer all polymers, and additives, other than soda ash, shall be NSF/ANSI Standard 060 compliant.
- B. Chemical Grout
 - 1. Design mix comprising a liquid base, reactant, water, accelerator, and other accepted admixtures as required.
 - 2. Liquid Base: Sodium silicate with a specific gravity between 1.4 and 1.5, and a silicate-to-soda ratio between 3.20 and 3.35. Colloidal silicate may be used as an alternative to sodium silicate as long as performance criteria can be met.

3. Reactant: Organic base type which, when properly mixed with other grout components, provides a permanent, irreversible gel with controllable gel times. The resulting gels shall exhibit less than 15 percent syneresis in 30 days when mixed with appropriate amounts of sodium silicate, water and accelerator, and not exhibit objectionable odors such as ammonia. Sodium bicarbonate, sodium aluminates and other reactants that produce a temporary grout are prohibited.
4. Water: Potable.
5. Accelerator: Technical grade, water-soluble calcium chloride or other metal salt, containing a minimum amount of insoluble materials.

2.2 EQUIPMENT AND ANCILLARY CONSTRUCTION MATERIALS

- A. Equipment and materials shall be as per the grout manufacturer's written recommendations and acceptable to the Engineer.
 1. Equipment and materials shall be sized to exceed the project requirements by at least 20% as measured by maximum proportioning quantities, maximum injection quantities, maximum pressure, and anticipated ground conditions.
 2. Materials left in the ground shall not damage or otherwise impede other construction as specified elsewhere.
 3. Keep spare parts and materials available onsite at all times.
- B. Cement and Solution Permeation Grouting Equipment
 1. Grout pipes - Sleeve-port type with centralizers as required to protect sleeves. After being placed in borehole encase the sleeve-port grout pipes in a continuous brittle mortar sheath. Use an internal double packer to inject grout at a specific sleeve port.
 2. Single Hole Packers
 - a. Packers shall be flow through type.
 - b. Pneumatic inflatable packers shall be used; leather packers will not be permitted.
 3. Double Packers
 - a. Pneumatic inflatable packers shall be used; leather packers will not be permitted.
 - b. The packer system shall be tested at the maximum injection rate of 40 gal/min.

- c. The packer depths shall be verified to the nearest 0.1 foot throughout testing.
 4. Valves and Gauges
 - a. Valve pressure ratings shall be at least 150% of maximum pump pressures.
 - b. Provide one gauge at grout pump, one gauge on manifold hookup at collar of hole being grouted, and one accurately calibrated master gauge.
 - c. Gages shall have accuracy better than +/- 0.5 psi.
 - d. Gages shall be calibrated before mobilization to the site.
 5. Drilling equipment - Capable of installing the sleeve port grout pipe given the site conditions and grouting requirements such as lost point drilling system with retractable casing; capable of installing drill casing to the accepted depths or horizontal penetration accurately in accordance with the reviewed and accepted Shop Drawings. Rotary drive and/or percussion drilling methods utilizing air, foam, or water flushing may be employed. Maintain grouting equipment in good operating condition at all times.
- C. Cement Permeation Grouting Equipment:
 1. General:
 - a. Provide stop valve at collar of hole for use in maintaining pressure until grout has set.
 2. System:
 - a. Provide for continuous circulation of grout in the system and to permit accurate pressure control at the grout hole connection.
 - b. Equip with means for periodic flushing system with water. Accomplish with grout intake valves closed, with water supply valve open, and with grout pump running at full speed.
 3. Mixer: High speed colloidal-type of equal or greater capacity than pumping equipment.
 4. Agitator tanks: Mechanical type with twice the capacity of the mixer.
 5. Meters:
 - a. At mixer for measuring amount of mixing water added to grout dry ingredients with accuracy to 0.25 gpm.

- b. Totalizing-type at collar of hole with accuracy to nearest liter.
- 6. Pump:
 - a. Capable of developing pressure at the grout hole connection in a continuous, uniform manner, up to the maximum pressure required.
 - b. Equipped with bypass valve to prevent sudden or excessive pressure from developing at the grout hole connection.
- D. Solution Permeation Grouting Equipment
 - 1. General: Continuous mixing type.
 - 2. Meters: Equipment plant with automatic, real-time display, positive displacement meters that measure and record the volume of each component pumped. Locate meters at the injection point and in each material line ahead of mixer. Meter accuracy shall be within 0.25 gpm and independent of fluid viscosity.

PART 3 - EXECUTION

3.1 GENERAL

- A. Perform all work in accordance with accepted submittals.
- B. The Contractor shall comply with all applicable permits.
- C. Do not commence any grouting operation until all submittals, including submittals for all related work specified elsewhere, are reviewed and accepted by the Engineer.
- D. Maintain a copy of the Contract Documents at a location acceptable to the Engineer and accessible to the grout operator and the Engineer.
- E. Provide the Engineer and the City with access to the grouting operations at all times during grouting operations.
- F. Survey pre-treatment locations in accordance with the General Conditions.
- G. Complete Daily grout shift report.
- H. Protect all existing adjacent facilities in accordance with the General Conditions.

3.3 CEMENT PERMEATION GROUTING PROCEDURES:

- A. Cement grout which is not injected into the hole within 1 hour after mixing or 30 minutes if the mix contains fluidizer with expanding agent shall be removed from the mixer, sump, and supply line and shall be wasted.

- B. If the water pressure testing indicates a relatively tight hole, grouting shall be started with a thin grout mixture. For an open hole condition, the water-cement ratio shall be reduced accordingly and, with the grout pump operating as nearly as practicable at constant speed at all times, the ratio shall be reduced further, if necessary, until the required pressure has been reached. If the pressure tends to rise too high, near the maximum specified pressure, the water-cement ratio shall be changed as directed.
- C. The water-cement ratio by volume will be varied to meet the characteristics of each hole as revealed by the pressure washing and testing operations and will normally range between 3.0:1.0 and 0.6:1.0.
- D. If it is found impossible to reach the required pressure after pumping a reasonable volume of grout at the minimum workable water-cement ratio, a sanded grout mix shall be used, the pumping speed shall be reduced, or pumping stopped temporarily and intermittent grouting shall be performed, allowing sufficient time between grout injections for the grout to stiffen.
- E. If excessive grout takes are still observed, grouting in the hole shall be discontinued, if so directed. In such event, the hole shall be cleaned, the grout allowed to set, and additional drilling and grouting be done in this hole or in the adjacent area, as directed, until the desired resistance is built up.
- F. Under no conditions shall the pressure or rate of pumping be increased suddenly, because either may produce a water-hammer effect which may promote stoppage. After the grouting of any hole is completed, the pressure shall be maintained by means of a stopcock or other suitable device until the grout has set to the extent that it will be retained in the hole.

3.4 SOLUTION PERMEATION GROUTING PROCEDURES:

- A. Mixing of chemical grout shall be performed by the continuous mixing method, with the proper amounts of sodium silicate base material, water, reactant and admixtures automatically proportioned and continuously supplied at proper flow rates and pressures. The batch system of mixing grout will not be permitted. Pass the base material and the water-accelerator- catalyst solution through parallel separate hoses to a baffling chamber near the top of the hole.
- B. Using double packers, inject chemical grout into the design zones through ports in the sleeve pipes. Temporary high injection pressures not exceeding one minute in duration will be permitted to crack open sleeve-ports. Continue to inject grout until the specified refusal criteria have been met.
- C. Do not exceed a rate of ten gallons per minute into any port.

3.5 REPAIR/RESTORATION FOR CEMENT AND SOLUTION PERMEATION GROUTING

- A. Abandon grout holes as provided in the accepted submittals.

- B. Ensure grout pipes left in place do not impede all tunneling operations. If so, remove grout pipes to the extent necessary to not affect operations.
- C. Remove grout pipe installed on private property to a depth of 10 ft. unless otherwise specified in the Contractor's agreement with the property owner.

3.6 FIELD QUALITY CONTROL

- A. Provide at the site the necessary quality control testing devices required to conduct material acceptance tests, proportioning tests, and grout quality tests for proper quality control of the Work.
- B. Before the start shaft excavation operation, Contractor shall demonstrate to the Engineer, through the accepted quality control plan, that the specified grout zone has been thoroughly impregnated and stabilized with grout.
- C. Permeation Grout shall have a gel time of five to 40 minutes, and not more than 40 minutes with 90 percent of the grout having gel times of ten to 30 minutes. Changes in gel time shall be accepted by the Engineer prior to implementation. Samples obtained for gel time checks: at least one every half hour of pumping or for every 500 gallons of grout, whichever is more frequent.
- D. Gel samples shall be properly containerized, labeled and stored until completion of the work.
- E. General: Check plant meter accuracy at least twice daily.
- F. Solution Permeation Grouting Proof tests: Prepare 1 chemically grouted soil sample with actual grout from the field from the in-situ samples taken prior to commencement of the work for each 500 gallons of grout pumped and test in accordance with ASTM D4219.

3.7 ADJUSTING

- A. Closely monitor the rate of grout take during grout injection. Ascertain the cause of sudden drops in grout injection pressures following initial start-up pressure adjustments. Continuously monitor adjacent paved and unpaved areas, adjacent gravity sewers, storm drains and other utilities for grout leakage. In the event that grout leaks are observed, temporarily terminate injection and plug leaks before resuming grouting.
- B. If excessive grout take is experienced that is not attributable to leakage, change injection pressure, pumping rates, gel or setting times, or grout composition, subject to the acceptance of the Engineer, to reduce grout use to acceptable levels.

3.8 CLEAN UP

- A. Segregate chemical or cement grout contaminated groundwater, including the products of syneresis degrading of gelled grouts.

- B. The Contractor shall provide waste containment sized appropriately to collect all waste generated. Containment, handling, and disposal of all waste shall be in accordance with the General Conditions.
- C. Site restoration shall be completed in accordance with the Contract Documents.

END OF SECTION

DIVISION 4
MASONRY

DIVISION 5
METALS

PART 1 – GENERAL

1.1 SCOPE

- A. This Section covers cast-in-place anchor bolts, epoxy grouted anchor bolts, threaded rod anchors, adhesive anchors, and expansion anchors to be installed in hardened concrete and masonry.
- B. Adhesive for the adhesive anchors is specified herein. Epoxy grouting of anchor bolts and threaded rod anchors is covered in the grout section.

1.2 GENERAL

- A. Unless otherwise specified or indicated on the Drawings, all anchor bolts shall be cast-in-place bolts, shall have a diameter of at least 3/4 inch, and shall be straight-headed, straight with embedded nut with or without a plate, or L-shaped. Epoxy grouted anchor bolts, threaded rod anchors which are epoxy grouted, and adhesive anchors indicated or accepted instead of cast-in-place anchor bolts for equipment or structural framing shall be at least 3/4 inch in diameter. All cast-in-place anchors in grout-filled masonry shall be at least 1/2 inch but not more than 3/4 inch in diameter. All expansion anchors shall be at least 1/2 inch in diameter.
- B. Anchor bolts and threaded rod anchors for buried service and in splash zones shall be hot-dip galvanized. Anchor bolts, threaded rod anchors, adhesive anchors, and expansion anchors for immersed service shall be stainless steel. Expansion anchors and adhesive anchors for buried service and in splash zones shall be stainless steel. All other anchor bolts, threaded rod anchors, adhesive anchors, and expansion anchors shall be carbon steel unless otherwise specified or indicated on the Drawings.

PART 2 – PRODUCTS

2.1 MATERIALS

- A. Anchor Bolts and Nuts
 - 1. Carbon Steel ASTM A307
 - 2. Stainless Steel Bolts, ASTM F593, Alloy Group 1 or 2; nuts, ASTM F594, Alloy Group 1 or 2.
 - 3. Galvanized Steel Carbon steel bolts and nuts; hot-dip galvanized, ASTM A153 and A385.
- B. Threaded Rod Anchors and Nuts
 - 1. Carbon Steel ASTM A307 or A36.
 - 2. Stainless Steel Bolts, ASTM F593, Alloy Group 1 or 2; nuts, ASTM F594, Alloy Group 1 or 2.
 - 3. Galvanized Steel Carbon steel bolts and nuts; hot-dip galvanized, ASTM A153 and A385.

- C. Adhesive Anchors (for concrete)
 - 1. System:
 - Hilti "HIT HY150 System", ITW Ramset /Redhead "C6 epoxy adhesive", or Rawlplug "R-KEM" metnacrylate resin system.
 - a. Threaded Rod Anchors and Nuts: Hilti HSE 2421 High Strength Epoxy.
 - b. Adhesive: Two-component liquid, moisture-insensitive epoxy adhesive with viscosity appropriate for the location and application.
- D. Flat Washers: ANSI B18.22.1; of the same material as anchor bolts and nuts.
- E. Expansion Anchors for Concrete:
 - Hilti "Kwik-Bolt 3", ITW Ramset/Red Head "Trubolt Wedge Anchor", or Rawlplug "Rawloct".
- F. Reinforcing Bars: ASTM A615, Grade 60, deformed.

PART 3 – EXECUTION

3.1 ANCHORS

- A. Anchor bolts shall be cast in place and, when acceptable to the ENGINEER or indicated on the Drawings, may be epoxy grouted anchor bolts, threaded rod anchors, or adhesive anchors. Anchor bolts, threaded rod anchors, and adhesive anchors which are to be epoxy grouted shall be clean and free of coatings that would weaken the bond with the epoxy.
- B. Two nuts, a jam nut, and a washer shall be furnished for anchor bolts, threaded rod anchors, and adhesive anchors indicated on the Drawings to have locknuts; two nuts and a washer shall be furnished for all other anchor bolts, threaded rod anchors, and adhesive anchors.
- C. Anti-seize thread lubricant shall be liberally applied to projecting, threaded portions of stainless steel anchor bolts, threaded rod anchors, and adhesive anchors immediately before final installation and tightening of the nuts.
- D. Anchor Bolts. Anchor bolts shall be delivered in time to permit setting before the structural concrete is placed. Anchor bolts which are cast in place in concrete shall be provided with sufficient threads to permit a nut to be installed on the concrete side of the concrete form or the supporting template. Installation of anchor bolts is covered in the cast-in-place concrete section.
- E. Threaded Rod Anchors. When acceptable to the ENGINEER, threaded rod anchors may be used in locations where cast-in-place anchor bolts are

specified. Adhesive for threaded rod anchors shall be as specified in the grout section. The embedment depth for threaded rod anchors shall be at least fifteen (15) rod diameters.

- F. Adhesive Anchors. When adhesive anchors are indicated on the Drawings, only an acceptable adhesive anchor system shall be used. Alternative anchoring systems may be used only when acceptable to the ENGINEER. An acceptable adhesive anchor system may be used as an alternative in locations where epoxy grouted anchor bolts and threaded rod anchors are specified or indicated. The embedment depth for adhesive anchors shall be at least fifteen (15) rod diameters.
1. Adhesive for adhesive anchors shall be statically mixed in the field during application. All proportioning and mixing of the components shall be in accordance with the manufacturer's recommendations.
 2. When acceptable to the ENGINEER, adhesive anchors shall be anchored in holes drilled into hardened concrete or grout filled masonry. Diameter of holes shall be 1/16 inch larger than the outside diameter of the rod. Holes shall be prepared for of the anchors by removing all dust and debris using procedures recommended by the adhesive manufacturer.
 3. Adhesive anchors and holes shall be clean, dry, and free of grease and other foreign matter at the time of installation. The adhesive shall be placed, the rods shall be set and positioned, and the adhesive shall be finished, all in accordance with the recommendations of the material manufacturer. Care shall be taken to ensure that all spaces and cavities are filled with adhesive, without voids, and remain filled with adhesive until completion of the curing period. Adhesive shall be cured in accordance with the recommendations of the adhesive manufacturer.

3.2 EXPANSION ANCHORS.

- A. When expansion anchors are indicated on the Drawings, only an acceptable expansion anchor shall be used. Alternative anchoring systems may be used only when acceptable to the ENGINEER. Expansion anchors shall be installed in conformity with the manufacturer's recommendations for maximum holding power, but in no case shall the depth of the hole be less than six bolt diameters. The minimum distance between the center of any expansion anchor and an edge or exterior corner of concrete shall be at least six (6) times the diameter of the bolt. Unless otherwise indicated on the Drawings, the minimum distance between the centers of expansion anchors shall be at least twelve (12) times the diameter of the bolt.
- B. Nuts and washers for expansion anchors shall be as specified for anchor bolts. Anti-seize thread lubricant shall be liberally applied to threaded stainless steel components of expansion anchors immediately before installation.

END OF SECTION

DIVISION 6
WOOD AND PLASTIC

DIVISION 7
THERMAL AND MOISTURE
PROTECTION

DIVISION 8
DOORS AND WINDOWS

DIVISION 9
FINISHES

**DIVISION 10
SPECIALTIES**

DIVISION 11
EQUIPMENT

PART 1 - GENERAL

1.1 DESCRIPTION

A. General

1. The work of this Section consists of material specifications and installation of the Diffuser Structure within the Colorado River in accordance with the project Drawings.

B. Related sections include but are not limited to:

1. Section 02300 - Earthwork and Trenching
2. Division 3 – Concrete

1.2 SUBMITTALS

The following documents must be submitted in their entirety within one (1) complete package; submittal packages not including all of these items will be deemed incomplete and rejected without review:

- A. Product literature that includes information on the performance and operation of the valve, materials of construction, dimensions and weights, elastomer characteristics, and pressure ratings.
- B. Diffuser Dimensional Drawing – the drawing shall be a scaled version of the actual nozzle, generic Drawings with listed dimensions or will not be accepted.
- C. Hydraulic curves for each inlet nozzle showing headloss, jet velocity, and effective open area all versus flow rate. The hydraulic curves must accurately reflect the variable orifice characteristics inherent to duckbill valves. The backpressure rating of diffuser shall be indicated.
- D. Verification of Independent Laboratory Testing for Manufacturing Consistency - the nozzle manufacturer shall provide summary documentation of a report conducted by an Independent laboratory for hydraulic testing where multiple nozzles (at least four) of the same size and construction (stiffness) were tested to validate the submitted headloss characteristics and to prove the repeatability and consistency of the manufacturing process to produce the same hydraulic characteristics.
- E. Verification of Finite Element Analysis (FEA) - the nozzle manufacturer shall provide summary documentation of Finite Element Analysis modeling on representative duckbill nozzle sizes to determine deflection, stress and strain characteristics under various load conditions. Modeling must have been done for flowing conditions (positive differential pressure) and

reverse differential pressure.

- F. Report of independent testing that studied the flow distribution characteristics of duckbill valves installed on multiport manifolds. The manufacturer must have been in the business of manufacturing duckbill valves at the time the report was published.
- G. Report of independent testing that studied the initial dilution characteristics of duckbill valves. The manufacturer must have been in the business of manufacturing duckbill valves at the time the report was published.

1.3 QUALITY ASSURANCE

- A. Supplier shall have at least 15 years experience in the manufacture of "duckbill" style elastomeric valves, and at least ten (10) years experience with diffuser applications, and shall provide references and a list of installations upon request.
- B. The duckbill valve manufacture must have a registered Professional ENGINEER on staff whom, at the ENGINEER and/or OWNER's discretion, may be interviewed to discuss the submittals and technical knowledge of the hydraulic characteristics of variable orifice duckbill valves as they apply to the critical hydraulic operation and initial dilution characteristics of the outfall diffuser.

PART 2 - PRODUCTS

2.1 "Duckbill" ELASTOMERIC DIFFUSER VALVES

- A. The Flanged Diffuser Check Valves are to be all rubber and the flow operated check type fabricated integrally with a wire-reinforced riser. The port area shall contour down to a duckbill, which shall allow passage of flow in one direction while preventing reverse flow. The flange, riser, and Duckbill Diffusers shall be one-piece rubber construction with nylon reinforcement.
- B. The integral riser shall consist of an elastomer inner tube, a fabric reinforced body section with a helical wire reinforcement embedded in the body. The riser shall be covered with a synthetic rubber cover stock for protection against abrasion and gouging.
- C. The linear bill slit dimension to nominal valve size ratio shall be greater than 2.0.
- D. The flange drilling shall conform to ANSI B16.1 Class 125/ANSI B16.5, Class 150 standards. The Series 35W-RIS shall be furnished with stainless steel 316

back-up rings for installation.

- E. The Diffuser Check Valves shall be a variable orifice providing a non-linear jet velocity vs. flow characteristic, which maximizes jet velocity at low flow rates compared to fixed orifice nozzles, and a linear headloss vs. flow characteristic.
- F. Manufacturer shall have conducted an independent hydraulic test where multiple valves (at least four) of the same size and construction (stiffness) were tested to validate the submitted headloss characteristics and to prove the repeatability of the manufacturing process to produce the same hydraulic characteristics.
- G. Manufacturer shall have conducted independent hydraulic testing to study the flow distribution characteristics of duckbill valves installed on multiport manifolds.
- H. Manufacturer to have conducted Finite Element Analysis (FEA) on various duckbill valves to determine deflection, stress, and strain characteristics under various load conditions. Modeling must have been done for flowing conditions (positive differential pressure) and reverse differential pressure.
- I. The inlet ports/nozzles shall discharge an elliptically shaped jet. The nozzle must have been modeled by an independent laboratory using Laser Induced Fluorescence (LIF).
- J. Manufacturer must have conducted in-house backpressure testing on twelve (12) inch duckbill valves).
- K. Company name, plant location, valve size and serial number shall be bonded to outside of the check valve. Valves shall be manufactured in the USA.

2.2 FUNCTION

- A. When line pressure inside the valve exceeds the backpressure outside the valve, the differential pressure forces the bill of the valve open, allowing flow to discharge. This restriction causes an increase in the jet velocity of the discharge, while the shape of the opening creates a flattened elliptically-shaped jet to increase dispersion. When backpressure exceeds the line pressure, the bill of the valve is forced closed preventing backflow.

2.3 MANUFACTURER

- A. All valves shall be twelve (12) inch Series 35W-RIS, HYDRAULIC CODE NUMBER 2584 as manufactured by the Red Valve Co., Inc. of Carnegie,

PA 15106.

- B. The pre-approved manufacturer of these duckbill nozzles is Tideflex Technologies / Red Valve Company, 600 N. Bell Ave., Carnegie, PA 15106 (412)-279-0044. Alternate manufacturer's must be pre-approved by the ENGINEER, the CONTRACTOR shall submit to the ENGINEER at least twenty (20) days prior to the bid date a reference submittal package as defined within the section entitled Submittals (Section 1.2) showing that the alternate manufacturer can comply with the scope, performance and general intentions of this Specification.

PART 3 - EXECUTION

3.1 INSTALLATION

- A. Valve shall be installed in accordance with manufacturer's written Installation and Operation Manual and approved submittals.

3.2 MANUFACTURER'S CUSTOMER SERVICE

- A. Manufacturer's authorized representative shall be available for customer service during installation and start-up, and to train personnel in the operation, maintenance and troubleshooting of the valve.
- B. Manufacturer shall also make customer service available directly from the factory in addition to authorized representatives for assistance during installation and start-up, and to train personnel in the operation, maintenance and troubleshooting of the valve.

3.3 ACCEPTANCE

- A. Acceptance by the OWNER for the diffuser and fittings will be based on a Certificate of Compliance.
- B. Acceptance of the diffuser by the OWNER will be based on Measured or Tested Conformance for mixing zone requirements.

END OF SECTION

DIVISION 12
FURNISHINGS

DIVISION 13
SPECIAL CONSTRUCTION

DIVISION 14
CONVEYING SYSTEMS

DIVISION 15
MECHANICAL

PART 1 – GENERAL

- 1.1 DESCRIPTION: The work in this section consists of providing High Density Polyethylene (HDPE) pipe and fittings.
- 1.2 RELATED WORK SPECIFIED ELSEWHERE: Earthwork and Trenching – Section 02300.
- 1.3 QUALITY ASSURANCE: References, American National Standards Institute (ANSI), American Society for Testing and Materials (ASTM), Federal Specifications (FS), International Standards Organization (ISO), and manufacturer's printed recommendations.
- 1.4 SUBMITTALS: Material list naming each product to be used identified by manufacturer and type number, in accordance with Section 01340.
- 1.5 PRODUCT HANDLING: Handle pipe and fittings to insure delivery in a sound undamaged condition.
- 1.6 JOB CONDITIONS: Do not lay pipe when trenches or weather conditions are not suitable for such work.

PART 2 – MATERIALS

2.1 PIPE:

- A. Pipe shall be manufactured from a resin which meets ASTM D 3350 with a minimum cell classification of 445574C. HDPE resin shall be PE4710 as characterized by ASTM D3035. Pipe shall be manufactured to the dimensions of ASTM F 714. Pipe shall be have a minimum pressure ratings of:

DR 21 101 psi

The pipe shall contain no recycled compounds except that generated in the manufacturer's own plant from resin of the same specification from the same raw material. All HDPE pipe diameters on the drawings shall be "minimum finished outside diameter" and shall have a dimension ratio of 21.

2.2 FITTINGS:

- A. Butt Fusion Fittings - Fittings shall be made from HDPE pipe resin meeting ASTM D 3350 with a minimum cell classification of 445574C.

Molded butt fusion fittings shall have a manufacturing standard of ASTM D 3261. Fabricated fittings must have the same pressure rating as the pipe; a DR less than the pipe shall be used. Fabricated fittings are to be manufactured using a Data Logger to record temperature, fusion pressure, and a graphic representation of the fusion cycle shall be part of the Quality Control records.

- B. Electrofusion Fittings - Fittings shall be made from resin or pipe meeting ASTM D 3350 with a minimum cell classification of 445574C. Electrofusion Fittings shall meet the manufacturing standard of ASTM F 1055. Fittings shall have the same pressure rating as the pipe or higher unless otherwise specified on the plans.
- C. Flanged and Mechanical Joint Adapters - Flanged and Mechanical Joint Adapters shall be made from materials containing resin that meets ASTM D 3350 with a minimum cell classification of 445574C.

PART 3 – EXECUTION

3.1 GENERAL:

- A. Pipe and Fittings: Size as indicated on the plans. Install as shown in accordance with manufacturer's recommendations.

3.2 EARTHWORK AND TRENCHING: Section 02300.

3.3 HAULING, UNLOADING and DISTRIBUTING PIPE: During loading, transportation and unloading, every precaution shall be taken to prevent injury to the pipe. No pipe shall be dropped from cars or trucks, or allowed to roll down slides without proper retaining ropes. During transportation each pipe shall rest on suitable pads, strips, skids or blocks securely wedged or tied in place. Any pipe damaged shall be replaced.

3.4 FUSION:

- A. Sections of polyethylene pipe should be joined into continuous lengths on the jobsite above ground. The joining method shall be the butt fusion method and shall be performed in strict accordance with the pipe supplier's recommendations. The butt fusion equipment used in the joining procedures should be capable of meeting all conditions recommended by the pipe supplier. The butt fusion joining will produce a joint with weld strength equal to or greater than the tensile strength of the pipe itself. All field welds shall be made with fusion equipment equipped with a Data Logger. Temperature, fusion pressure and a graphic representation of the fusion cycle shall be part of the Quality Control records.

- B. Mechanical joining will be used where the butt fusion method cannot be used. Mechanical joining will be accomplished by either using a HDPE flange adapter with a ductile iron back-up ring.
 - C. Hot gas fusion, threading, solvents, and epoxies will not be used to join HDPE pipe.
- 3.5 INSPECTION: Inspect the pipe for defects before installation and fusion. Defective, damaged or unsound pipe will be rejected.
- 3.6 TESTING: Pressure testing shall be conducted in accordance with the ASTM F 2164, Field Leak Testing of Polyethylene Pressure Piping Systems Using Hydrostatic Pressure. The HDPE pipe shall be filled with water, raised to test pressure and allowed to stabilize. The test pressure shall be 1.5 times the operating pressure at the lowest point in the system. The pipe shall pass if the final pressure is within 5% of the test pressure for 1 hour. For safety reasons, hydrostatic testing only will be used.

PART 4 – MEASUREMENT AND PAYMENT

- 4.1 HDPE PIPE, FITTINGS AND ACCESSORIES: Payment will be included under the bid item to which the work relates.

END OF SECTION

PERMIT INFORMATION



DEPARTMENT OF THE ARMY
U.S. ARMY CORPS OF ENGINEERS, SACRAMENTO DISTRICT
1325 J STREET
SACRAMENTO CA 95814-2922

January 23, 2018

Regulatory Division (SPK-2016-00171)

City of Grand Junction Department of Public Works
Attn: Mr. Lee Cooper
250 North 5th Street
Grand Junction, Colorado 81501

Dear Mr. Cooper:

We are responding to your request for a Department of the Army permit for the Persigo Wastewater Treatment Plant (WWTP) Outfall Structure project. This project involves activities, including discharges of dredged or fill material, in waters of the United States to replace the current single source effluent discharge point with an across river effluent diffuser, requiring construction of a cofferdam. The project site is located on the right bank of the Colorado River, in and through Persigo Wash, extending to approximately the center of the Colorado River channel, in the SE ¼ of Section 36, Township 1 North, Range 2 West, Ute Meridian, near Latitude 39.110513°, Longitude -108.659410°, in the City of Grand Junction, Mesa County, Colorado.

Based on the information you provided, the proposed activity will permanently affect 0.07 acre and temporarily affect 1.19 acre of the Colorado River and adjacent wetlands. These impacts are authorized by Nationwide Permit (NWP) 39 Commercial and Institutional Developments. Your work must comply with the general terms and conditions listed on the enclosed NWP information sheets and the following special conditions:

- 1. To ensure your project complies with the Federal Endangered Species Act, you must implement all of the measures identified in the enclosed Fish and Wildlife Service letter of concurrence (ES/CO: COE-Water Quality, TAILS 06E24100-2016-I-0271) including those ascribed to the Corps therein. Please note, the Service finds the impacts to be insignificant to the federally listed species since the construction is proposed to be completed in winter months. If you are unable to implement any of these measures, you must immediately notify this office and the Fish and Wildlife Office so we may consult as appropriate, prior to initiating the work, in accordance with Federal law.**
- 2. You are responsible for all work authorized herein and ensuring that all contractors and workers are made aware and adhere to the terms and conditions of this permit authorization. You shall ensure that a copy of the permit authorization and associated drawings are available for quick reference at the project site until all construction activities are completed.**

3. Your use of the permitted activity must not interfere with the public's right to free navigation on all navigable waters of the United States.

This verification is valid until March 18, 2022, when the existing NWP's are scheduled to be modified, reissued, or revoked. Furthermore, if you commence or are under contract to commence this activity before the date the NWP is modified, reissued, or revoked, you will have 12 months from the date of the modification, reissuance or revocation to complete the activity under the present terms and conditions. Failure to comply with the general and regional conditions of this NWP, or the project-specific special conditions of this authorization, may result in the suspension or revocation of your authorization.

Please refer to identification number SPK-2016-00171 in any correspondence concerning this project. If you have any questions, please contact Travis Morse at the Grand Junction Regulatory Field Office, 400 Rood Avenue, Room 224, Grand Junction, Colorado 81501, by email at w.travis.morse@usace.army.mil, or by telephone at 970-243-1199 x1014.

We would appreciate your feedback on this permit action including your interaction with our staff. At your earliest convenience, please tell us how we are doing by completing the Corps' Regulatory Program national customer service survey found on our website at www.spk.usace.army.mil/Missions/Regulatory.aspx.

Sincerely,



Travis Morse
Senior Project Manager
Colorado West Regulatory Branch

Enclosure

1. NWP 39 Summary
2. Fish and Wildlife Service letter of concurrence
3. Compliance Certification

cc:

Mr. Collin Haggerty, Stantec Consulting LTD, colin.haggerty@stantec.com

Ms. Dana Brosig, Mesa County Planning and Economic Development,
dana.brosig@mesacounty.us

Ms. Erin Scott, Colorado Department of Public Health and Environment, erin.scott@state.co.us

Ms. Kris Monday, U.S. Fish and Wildlife Service, kris_monday@fws.gov

Mr. Rob McCaskey, U.S. Coast Guard, rob.e.mccaskey@uscg.mil

COMPLIANCE CERTIFICATION

Permit File Name: Persigo WWTP Outfall Structure

Action ID: SPK-2016-00171

Nationwide Permit Number: 39

Permittee: City of Grand Junction Department of Public Works
Attn: Mr. Lee Cooper
250 North 5th Street
Grand Junction, Colorado 81501

County: Mesa

Date of Verification: January 23, 2018

Within 30 days after completion of the activity authorized by this permit, sign this certification and return it to the following address:

U.S. Army Corps of Engineers
Sacramento District
Colorado West Regulatory Branch
400 Rood Avenue, Room 134
Grand Junction, Colorado 81501
(970) 243-1199
Fax (970) 241-2358
DLL-CESPK-RD-Compliance@usace.army.mil

Please note that your permitted activity is subject to a compliance inspection by a U.S. Army Corps of Engineers representative. If you fail to comply with the terms and conditions of the permit your authorization may be suspended, modified, or revoked. If you have any questions about this certification, please contact the U.S. Army Corps of Engineers.

I hereby certify that the work authorized by the above-referenced permit, including all the required mitigation, was completed in accordance with the terms and conditions of the permit verification.

Permittee Signature

Date

APPENDIX C

CDPHE Construction Dewatering Permit (Application Only)



For Agency Use Only:
Permit Number Assigned
COG07 - _____
COG315 - _____
COG316 - _____

**Application for COLORADO DISCHARGE PERMIT SYSTEM (CDPS)
 General Permits:**

- Construction Dewatering (COG070000)
- Remediation Activities Discharging To Surface Water (COG315000), or
- Remediation Activities Discharging To Groundwater (COG316000)

Please print or type. Original signatures are required. Photo, faxed, pdf or email copies will not be accepted.

This combined permit application is designed to streamline the application process for the three types of discharge permits listed in Part A below, and includes an *Application Guidance Document* to help applicants complete the application and select the right permit coverage for their activity. Please note that **one** application is intended to cover **one** project and **one** type of permit. Where multiple projects or types of permits are required, please submit an appropriate number of permit applications.

The application must be submitted to the Water Quality Control Division at least 30 days (for Construction Dewatering) or 45 days (for Remediation) prior to the anticipated date of discharge, and must be considered complete by the division before the review and approval process begins. The division will notify the applicant if additional information is needed to complete the application. If more space is required to answer any question, please attach additional sheets to the application form. Applications must be submitted by mail or hand delivered to:

**Colorado Department of Public Health and Environment
 Water Quality Control Division, WQCD-P-B2
 4300 Cherry Creek Drive South
 Denver, Colorado 80246-1530**

IMPORTANT: Please read the *Application Guidance Document (Guidance)* for this permit application prior to completing this application. The *Guidance* provides specific and important instructions required for completing this application correctly.

A. PERMIT INFORMATION

Reason for Application: NEW CERT
 RENEW CERT EXISTING CERT # _____

Applicant is: Property Owner Contractor/Operator

Application is for the following discharge permit (select ONE). See Guidance.

- Construction Dewatering (COG070000)
- Remediation Activities Discharging to Surface Water (COG315000)
- Remediation Activities Discharging to Groundwater (COG316000)

Note: This application is designed for processing each of the three permit types listed above. The division may request additional characterization of the proposed discharge to ensure that the appropriate permit coverage is requested and the appropriate permit certification is issued. The division may deny or change the requested type of discharge permit after review of the submitted application and will notify the applicant of the changes. Coverage under the "Subterranean Dewatering or Well Development" General Permit COG6030000 is not available using this application form.



B. CONTACT INFORMATION

1. Permittee Information

Organization Formal Name: _____

Permittee Name: the person **authorized to sign and certify** the permit application. This person receives all permit correspondences and is **responsible** for ensuring compliance with the permit.

Responsible Position (Title): _____

Currently Held By (Person): _____

Telephone No: _____

Email address: _____

Mailing Address: _____

City: _____ State: _____ Zip: _____

This form must be signed by the permittee to be considered complete. **Per Regulation 61, in all cases**, it shall be signed as follows:

- a) In the case of corporations, by a responsible corporate officer. For the purposes of this section, the responsible corporate officer is responsible for the overall operation of the facility from which the discharge described in the application originates.
- b) In the case of a partnership, by a general partner.
- c) In the case of a sole proprietorship, by the proprietor.
- d) In the case of a municipal, state, or other public facility, by either a principal executive officer or ranking elected official.

2. DMR Cognizant Official (i.e. authorized agent) the person or position authorized to sign and certify reports required by permits including Discharge Monitoring Reports [DMR's], Annual Reports, Compliance Schedule submittals, and other information requested by the division. The division will transmit pre-printed DMR's to this person. If more than one, please add additional pages.

Same as 1) Permittee

Responsible Position (Title): _____

Currently Held By (Person): _____

Telephone No: _____

Email address: _____

Organization: _____

Mailing Address: _____

City: _____ State: _____ Zip: _____

Per Regulation 61: All reports required by permits, and other information requested by the Division shall be signed by the permittee or by a duly authorized representative of that person. A person is a duly authorized representative only if:

- a) The authorization is made in writing by the permittee
- b) The authorization specifies either an individual or a **position having responsibility for the overall operation of the regulated facility or activity** such as the position of plant manager, operator of a well or a well field, superintendent, position of equivalent responsibility, or an individual or position having overall responsibility for environmental matters for the company. (A duly authorized representative may thus be either a named individual or any individual occupying a named position)
- c) Submitted in writing to the Division



B. CONTACT INFORMATION (cont.)

3. Site/Local Contact (contact for questions relating to the facility & discharge authorized by this permit.)

Same as 1) Permittee

Responsible Position (Title): _____

Currently Held By (Person): _____

Telephone No: _____

Email address: _____

Organization: _____

Mailing Address: _____

City: _____ State: _____ Zip: _____

4. Operator in Responsible Charge Required for Groundwater Remediation COG315000 or COG316000

Same as 1) Permittee

Same as 3) Site/ Local Contact

**Note: Where the division determines that coverage under the construction dewatering permit is appropriate, an ORC is not required.*

Operator Number _____ Legal Name: _____

Telephone No: _____ Email address: _____

Company: _____

5. Billing Contact

Same as 1) Permittee

Responsible Position (Title): _____

Currently Held By (Person): _____

Telephone No: _____

Email address: _____

Organization: _____

Mailing Address: _____

City: _____ State: _____ Zip: _____

6. Other Contact Types (check below) Add pages if necessary:

Responsible Position (Title): _____

Currently Held By (Person): _____

Telephone No: _____

Email address: _____

Organization: _____

Mailing Address: _____

City: _____ State: _____ Zip: _____

Environmental Contact

Facility Inspection Contact

Consultant

Compliance Contact

Property Owner

Other _____



C. PERMITTED FACILITY INFORMATION

Facility or Project Name _____

Street Address (or cross streets) _____

City _____ Colorado, Zip Code _____

County _____

Type of Facility Ownership

- City Government Corporation Private Municipal or Water District
- State Government Mixed Ownership _____

Facility or Project Latitude/Longitude – List the latitude and longitude of the excavation resulting in the discharge(s). If the exact excavation location(s) are not known, list the latitude and longitude of the center point of the construction project. If using the center point, be sure to specify that it is the center point of construction activity.

Latitude _____. _____ Longitude _____. _____
 Provide coordinates in decimal degrees to 6 decimal places (e.g., 39.703345°, -104.933567°)

Horizontal Collection Method: GPS Unspecified Interpolation Map - Map Scale Number _____
 Reference Point: Project/Facility Entrance Project/Facility Center/Centroid

Horizontal Reference Datum: _____

Standard Industrial Classification (SIC) Code(s) for this FACILITY (include up to 4, in order of importance)

1 _____ 2 _____ 3 _____ 4 _____

Receiving Water _____

D. PROJECT DESCRIPTION

D.1. Description of Activity:

- a) Provide a brief overview of the project and dewatering activity (e.g., highway, bridge and tunnel construction, storm drain expansion, etc.).

- b) Is the dewatering and discharge in-stream? (The dewatering operation is considered in-stream where the dewatering activity is conducted within approximately the ordinary high water mark of the stream and/or on the bank of the stream and the discharge is back to the same water body.)
 Yes * No

**If yes, you must provide a description of how your project meets this definition in the box below. If no description is provided, the work will not be considered in-stream. Please note that in-stream work activities may also require a separate Clean Water Act Section 404 Permit and Colorado 401 Certification.*



- c) Will the project involve a temporary stream diversion (e.g. diversion channel, pump-around, piped diversion, coffer dam) to reroute water around the construction area?
 Yes * No

**By checking yes, the applicant understands that temporary water diversions are not covered under the permit certification and may require coverage under a Clean Water Act Section 404 Permit. Only dewatering discharge outfalls associated with construction-related activities may be covered under the permit certification.*

- d) Will dewatering be conducted in areas that involve work on (e.g. replacing, repairing, making connections to, etc...) existing sanitary sewer lines, conveyances, or vessels, or in proximity to septic disposal systems?
 Yes No

If yes, is there the potential that sewage or septage could be in the effluent to be discharged?

- Yes No *

**If no, you must provide a description of the control measures that will be implemented to prevent sewage or septage from entering the discharge (use the box below). The division may add effluent limits for E. coli and/or Total Coliform if the applicant does not demonstrate that adequate measures will be in place.*

D.2 Description of Discharge:

- a) Is the discharge to a ditch or storm sewer system? Yes* No

**If yes, the applicant must contact the owner of the ditch or storm sewer system prior to discharging to address any local ordinances and to determine if additional requirements will be imposed by the owner.*

- b) Is the discharge to an impoundment? Yes* No

- c) Discharge Frequency and Duration:

- Estimated discharge start date: _____
- Estimated discharge duration: Years _____ Months _____ Days _____
- Upon completion of construction phase dewatering, will there be long-term subterranean dewatering at the site (e.g. foundation, footer, toe drains, etc...)? Yes* No

**If yes, note that construction phase dewatering and long-term subterranean dewatering cannot be covered under the same permit certification.*

- d) Provide a brief description of the Best Management Practices (BMPs) to be used in the box below.

D.3 Discharge Outfalls (Limit 20 outfalls):

- Total number of **defined** outfalls requested: _____
- Total number of **undefined** outfalls requested: _____ (construction dewatering only)
- Complete Table 2a (for discharges to surface water) and/or 2b (for discharges to land with percolation to groundwater) to identify your defined and undefined outfall locations. Attach additional pages as necessary.



Table 2a - Requested Outfalls for Discharges to Surface Water (Discharges that may reach surface water through direct discharge or through a conveyance such as a ditch or a storm sewer system)				
OUTFALL NUMBER ¹	NAME OF RECEIVING STREAM(S) (e.g., Cherry Creek, Boulder Creek, Arkansas River)	ESTIMATED MAXIMUM FLOW RATE ² (gpm)	DESCRIPTION OF DISCHARGE LOCATION ³ (e.g., Discharge enters storm sewer located at the corner of Speer and 8 th Ave. with flow to Cherry Creek)	LATITUDE/LONGITUDE OF EACH DISCHARGE OUTFALL
Defined Discharges to Surface Water				
001-A				
002-A				
003-A				
004-A				
Undefined Discharges to Surface Water (Available for construction dewatering only) (Provide <i>estimated lat/long</i> only for undefined outfalls)				
001-AU				
002-AU				
003-AU				
004-AU				

1 Identify up to 20 defined or undefined outfalls (undefined for construction dewatering only). Use additional pages as necessary.

2 For construction dewatering the maximum flow limit will be equal to twice the estimated maximum flow rate provided in the permit application. For groundwater remediation the 30-day average flow limit will be based on the design capacity of the treatment as provided in the permit application.

3 The discharge location is the point where effluent sampling will occur. This location must be at a point after treatment and before the effluent joins or is diluted by any other waste stream, body of water, or substance. If the discharge is to a ditch or storm sewer system, include the name of the ultimate receiving waters where the ditch or storm sewer discharges.



Table 2b - Requested Outfalls for Discharges to Land with the Potential to Percolate to Groundwater (These discharges do not have the potential to reach surface water either directly or through a conveyance.) ⁴			
OUTFALL NUMBER ¹	ESTIMATED MAXIMUM FLOW RATE ² (gpm)	DESCRIPTION OF DISCHARGE LOCATION ³ (e.g., Discharge to a field south of project site and East of I-25)	LATITUDE/LONGITUDE OF EACH DISCHARGE OUTFALL
Defined Discharges to Land with Potential Percolation to Groundwater			
G001-A			
G002-A			
G003-A			
G004-A			
Undefined Discharges to Land with Potential Percolation to Groundwater (Available for construction dewatering only) (Provide <i>estimated lat/long</i> only for undefined outfalls)			
G001-AU			
G002-AU			
G003-AU			
G004-AU			

1 Identify up to 20 defined or undefined outfalls (undefined for construction dewatering only). Use additional pages as necessary.

2 For construction dewatering the maximum flow limit will be equal to twice the estimated maximum rate flow rate provided in the permit application. For groundwater remediation the 30-day average flow limit will be based on the design capacity of the treatment as provided in the permit application.

3 The discharge location is the point where effluent sampling will occur. This location must be at a point after treatment and before the effluent joins or is diluted by any other waste stream, body of water, or substance.

4 For discharges of uncontaminated groundwater to land, please review and consider the applicability of the division's *Low Risk Discharge Guidance: Discharges of Uncontaminated Groundwater to Land* before submitting a permit application to the division. This policy is available for download at <https://www.colorado.gov/pacific/cdphe/clean-water-construction-compliance-assistance-and-guidance>.



E. ADDITIONAL INFORMATION

E.1 Nearby Sources of Potential Groundwater Contamination:

- a) Has the proposed dewatering area been reviewed for possible groundwater contamination, such as plumes from leaking underground storage tanks (LUSTs), hazardous waste sites, or additional sources other than what is normally encountered at excavation and construction sites? *Applicants are expected to exercise due diligence in evaluating their project sites prior to applying for a discharge permit.*

Yes No

- b) Is an open LUST located within **one-half mile** of the site?

Yes* No

**If yes, BTEX analytical data for a source water sample representative of the proposed discharge at the site must be included with the permit application. Failure to include this data may result in delays in processing the permit application until such data is submitted to the Division. See Guidance.*

- c) Is a Superfund site or National Priorities List (NPL) site located within **one mile** of the site?

Yes* No

**If yes, analytical data for all parameters shown in Table 1 of this application (or an alternate list of constituents approved by the division) for a source water sample representative of the proposed discharge must be included with the permit application. Failure to include this data may result in delays in processing the permit application until such data is submitted to the Division. See Guidance.*

- d) Is any other (non-LUST, non-Superfund, non-NPL site) known source of contamination, such as a Voluntary Cleanup (VCUP), Environmental Covenant, open RCRA Corrective Action site, or brownfields site located within **one-half mile** of the site?

Yes* No

**If yes, analytical data for all parameters shown in Table 1 of this application (or an alternate list of constituents approved by the division) for a source water sample representative of the proposed discharge must be included with the permit application. Failure to include this data may result in delays in processing the permit application until such data is submitted to the Division. See Guidance.*

- e) If known sources of contamination are located near the site, provide an overview of the source and nature of contamination including:

- The nature of the contamination of the groundwater, alluvial water, stormwater, and/or surface water (the source water) for which treatment and/or remedial activities will occur,
- The primary industrial activities which resulted in the source water contamination,
- The source of the contamination (pipes, leaking underground storage tank, up gradient sources, etc.) or state "unknown."



- f) For contaminated discharges (remediation), provide a narrative description of the type(s) of treatment proposed for use at each identified outfall.

E.2 Chemical Additions

List any chemical additives or other materials to be used in the water or to treat water prior to discharge. Include the Material Safety Data Sheet (MSDS) for each chemical with the application.

CHEMICAL NAME	MANUFACTURER	PURPOSE	DOSAGE

E.3 Site Maps and Schematics

- Are required maps and schematics attached? Yes No-Application cannot be processed without required maps

- ✓ **Location Map(s) for Outfalls** - Application must include a location map(s) that shows the location of the project/facility, the limits of the construction activity, the approximate location of the requested discharge point(s)/outfalls, and the location of potential receiving water(s). If known, the map should also include the approximate location(s) where dewatering is to occur and the location of proposed BMP(s) to be used. A north arrow must be shown. **Maps must be on paper that can be folded to 8 ½ x 11 inches.**

E.4 Associated Permits

Does the applicant have a Stormwater Permit for Construction Activities? YES NO PENDING
 If Yes, Stormwater Construction Permit Number: COR-_____

Does the applicant have a Clean Water Act Section 404 Permit? YES NO PENDING



E.5 Water Rights

The State Engineers Office (SEO) has indicated that any discharge that does not return water directly to surface waters (i.e. land application, rapid infiltration basins, etc.) has the potential for material injury to a water right. As a result, the SEO needs to determine that material injury to a water right will not occur from such activities. To make this judgment, the SEO requests that a copy of all documentation demonstrating that the requirements of Colorado water law have been met, be submitted to their office for review. The submittal should be made as soon as possible to the following address:

Colorado Division of Water Resources • 1313 Sherman Street, Room 818 • Denver, Colorado 80203

Should there be any questions on the issue of water rights; the SEO can be contacted at (303) 866-3581. It is important to understand that any CDPS permit issued by the division does not constitute a water right. Issuance of a CDPS permit does not negate the need to also have the necessary water rights in place. It is also important to understand that even if the activity has an existing CDPS permit, there is no guarantee that the proper water rights are in place.

F. REQUIRED CERTIFICATION SIGNATURE [Reg 61.4(1)(h)]

"I certify under penalty of law that this document and all attachments were prepared under my direction or supervision in accordance with a system designed to assure that qualified personnel properly gather and evaluate the information submitted. Based on my inquiry of the person or persons who manage the system, or those persons directly responsible for gathering the information, the information submitted is to the best of my knowledge and belief, true, accurate and complete. I am aware that there are significant penalties for submitting false information, including the possibility of fine and imprisonment for knowing violations."

Signature (Legally Responsible Party (Page 2 item 1) _____

Date _____

Name (printed) _____ Title _____

This form must be signed by the permittee to be considered complete. **Per Regulation 61, in all cases**, it shall be signed as follows:

- a) In the case of corporations, by a responsible corporate officer. For the purposes of this section, the responsible corporate officer is responsible for the overall operation of the facility from which the discharge described in the application originates.
- b) In the case of a partnership, by a general partner.
- c) In the case of a sole proprietorship, by the proprietor.
- d) In the case of a municipal, state, or other public facility, by either a principal executive officer or ranking elected official.



ATTACHMENT 1

Please Submit the Laboratory Data Package for any Required Analysis with the Permit Application
(See Important Table Notes)

Required Water Quality Data			
<u>Metals</u>	<u>PQL (ug/l) ¹</u>	<u>Metals</u>	<u>PQL (ug/l) ¹</u>
Aluminum-Trec	15	Lead-PD	0.5
Antimony-Trec	2	Manganese-PD	2
Arsenic-Trec	1	Manganese-Diss	2
Arsenic-PD	1	Molybdenum-Trec	0.5
Barium-Trec	1	Nickel-Trec	1
Beryllium-Trec	2	Nickel-PD	1
Cadmium-Trec	0.5	Selenium-Trec	1
Cadmium-PD	0.5	Selenium-PD	1
Chromium III-Trec	20	Silver-Trec	0.5
Chromium III-PD	20	Silver-PD	0.5
Chromium VI-Diss	20	Thallium-Trec	0.5
Chromium-Trec	20	Thallium-PD	0.5
Copper-Trec	2	Uranium-PD	1
Copper-PD	2	Uranium-Trec	1
Iron-Trec	20	Zinc-Trec	10
Iron-Diss	20	Zinc-PD	10
Lead-Trec	0.5		
<u>Volatiles</u>	<u>PQL (ug/l) ¹</u>	<u>Volatiles</u>	<u>PQL (ug/l) ¹</u>
acrolein	15	ethylbenzene	75
benzene	3	methyl bromide	5
bromoform	3	methyl chloride	4.5
carbon tetrachloride	3	1,1,2-tetrachloroethane	2
chlorobenzene	60	tetrachloroethylene	2.3
chlorodibromomethane	3	toluene	60
2-chloroethylvinyl ether	0.65 *	1,2-trans-dichloroethylene	0.5 *
chloroform	3	1,1,1-trichloroethane	5
1,2-dichlorethane	3	1,1,2-trichloroethane	2.0
1,1-dichlorethylene	5	trichloroethylene	2.3
1,2-dichloropropane	2	vinyl chloride	3
1,3-dichlorpropylene	2 *	1,4-Dioxane	0.15 *
<u>Semi-Volatile Organic Compounds</u>	<u>PQL (ug/l) ¹</u>	<u>Semi-Volatile Organic Compounds</u>	<u>PQL (ug/l) ¹</u>
acenaphthene	20	1,2-diphenylhydrazine (as azobenzene)	5 *
acenaphthylene	30	fluorene	20
anthracene	20	fluoranthene	25
benzidine	170	hexachlorobenzene	16
benzo(a)anthracene	12	hexachlorobutadiene	9
benzo(a)pyrene	20	hexachlorocyclopentadiene	50
benzo(b)fluoranthene	35	hexachloroethane	16
benzo(ghi)perylene	20	indeno(1,2,3-cd)pyrene	20
benzo(k)fluoranthene	25	isophorone	25
bis(2-chloroethyl)ether (or Dichloroethyl ether)	15	naphthalene	20
bis(2-chloroisopropyl)ether (or 2,2-dichloroisopropyl ether)	60	nitrobenzene	19
bis(2-ethylhexyl)phthalate	25	N-nitrosodimethylamine	30

<u>Semi-Volatile Organic Compounds</u>	<u>PQL (ug/l) ¹</u>	<u>Semi-Volatile Organic Compounds</u>	<u>PQL (ug/l) ¹</u>
Butyl benzyl phthalate	25	N-nitrosodi-n-propylamine	30
2-chloronaphthalene	20	N-nitrosodiphenylamine	19
chrysene	18	pyrene	10
dibenzo(a,h)anthracene	20	1,2,4-trichlorobenzene	20
1,2-dichlorobenzene	2.5	2-chlorophenol	35
1,3-dichlorobenzene	2.5	2,4-dichlorophenol	30
1,4-dichlorobenzene	3.5	2,4,-dimethylphenol	30
3,3-dichlorobenzidine	18	4,6-dinitro-o-cresol	17
diethyl phthalate	20	2,4-dinitrophenol	100
dimethyl phthalate	20	4-nitrophenol	25
di-n-butyl phthalate	25	pentachlorophenol	36
2,4-dinitrotoluene	17	phenol	15
2,6-dinitrotoluene	20	2,4,6-trichlorophenol	25
xylene	10 *	1,4-Dioxane	0.15 *

¹ PQLs are as listed in the division's *Practical Quantitation Limits Policy* (CW 6) unless noted otherwise.

* This is a recommended PQL based on EPA approved methods. The division's *Practical Quantitation Limits Policy* (CW 6) does not provide a 40 CFR 136 based PQL for this parameter.

Trec = Total Recoverable

PD = Potentially Dissolved

Diss = Dissolved

PQL = Practical Quantitation Limit

Important table notes:

- 1) Please refer to the permit application Guidance to determine whether analytical data is required with the permit application, and if so, what specific type of data is required.
- 2) Parameter names match the names as they appear in the general permit or, as italicized, as they appear in the division's *Practical Quantitation Limits Policy* (CW-6).
- 3) The division may require analytical data for additional parameters where the project site is located in close proximity to potential sources of contamination for parameters not included in this Attachment 1, including but not limited to pesticide, PCB, radionuclide contamination.
- 4) Applicants applying under the General Permit for Remediation Activities Discharging to Groundwater (COG316000) are encouraged to contact the division prior to sample collection to ensure that the correct metal speciation is included in the sample analysis.
- 5) For the permit application, all sampling should be performed according to specified methods in 40 CFR 136, methods approved by EPA pursuant to 40 CFR 136, or methods approved by the division, in the absence of a method specified in or approved pursuant to 40 CFR 136. In addition, the PQLs listed in Attachment 1 should be met unless otherwise approved by the division.

APPENDIX D

USGS Colorado River Flows – Daily Average River Flows



USGS Home
 Contact USGS
 Search USGS

National Water Information System: Web Interface

USGS Water Resources

Data Category: Geographic Area:

Click to hide News Bulletins

[Please see news on new formats](#)

- [Full News](#)

USGS Surface-Water Daily Statistics for the Nation

The statistics generated from this site are based on approved daily-mean data and may not match those published by the USGS in official publications. The user is responsible for assessment and use of statistics from this site. For more details on why the statistics may not match, [click here](#).

USGS 09163500 COLORADO RIVER NEAR COLORADO-UTAH STATE LINE

Available data for this site

Mesa County, Colorado Hydrologic Unit Code 14010005 Latitude 39°07'58", Longitude 109°01'35" NAD27 Drainage area 17,849 square miles Gage datum 4,325 feet above NGVD29	Output formats <input type="button" value="HTML table of all data"/> <input type="button" value="Tab-separated data"/> <input type="button" value="Reselect output format"/>
---	--

00060, Discharge, cubic feet per second,											
Day of month	Mean of daily mean values for each day for 8 - 9 years of record in, ft3/s (Calculation Period 2007-10-01 -> 2017-01-01)										
	Period-of-record for statistical calculation restricted by user										
	Jan	Feb	Mar	Apr	May	Jun	Jul	Aug	Sep	Oct	Nov
1	2,820	2,920	3,000	3,520	6,340	18,200	12,200	4,820	4,040	4,230	4,230
2	2,740	2,790	2,990	3,650	6,370	18,500	11,800	4,800	3,990	4,280	4,080
3	2,710	2,730	3,030	3,740	6,350	19,100	11,200	4,810	3,900	4,160	3,860
4	2,740	2,720	3,010	3,870	6,240	19,800	10,900	4,850	3,860	4,080	3,850
5	2,810	2,750	3,040	3,770	6,530	20,400	10,400	4,950	3,790	4,140	3,720
6	2,890	2,810	3,000	3,610	7,300	22,000	10,000	4,810	3,780	4,240	3,700
7	2,910	2,840	3,010	3,570	8,990	23,300	9,890	4,680	3,800	4,300	3,630
8	2,950	2,860	3,100	3,540	10,100	23,600	9,570	4,520	3,840	4,300	3,600
9	2,980	2,820	3,120	3,690	10,700	23,200	9,520	4,370	4,010	4,240	3,550
10	2,920	2,840	3,060	3,990	11,100	22,300	9,530	4,190	4,410	4,280	3,540
11	2,880	2,880	3,030	4,250	11,100	21,900	9,200	4,020	4,270	4,340	3,530
12	2,820	2,870	3,080	4,460	11,300	21,300	8,890	3,900	4,240	4,240	3,470
13	2,780	2,870	3,110	4,680	11,200	20,800	8,600	3,780	4,190	4,160	3,380
14	2,810	2,910	3,180	4,790	11,300	19,800	8,260	3,780	4,230	4,160	3,370
15	2,870	2,920	3,190	4,680	11,700	19,000	7,850	3,800	4,330	4,200	3,360
16	2,940	2,930	3,240	4,770	12,600	18,000	7,540	3,770	4,280	4,120	3,370
17	2,970	2,960	3,270	4,990	13,500	17,500	7,210	3,750	4,280	4,040	3,360
18	2,930	2,970	3,380	5,050	14,000	17,600	6,910	3,610	4,230	3,980	3,330
19	2,980	2,960	3,430	5,270	14,300	17,200	6,870	3,490	4,130	3,960	3,280
20	2,970	3,040	3,460	5,750	14,500	16,800	6,840	3,520	4,090	4,010	3,280
21	2,960	3,050	3,380	5,970	14,400	16,700	6,530	3,640	4,070	3,990	3,330
22	2,960	2,980	3,340	6,460	14,400	16,200	6,360	3,570	4,080	4,090	3,410
23	2,950	2,900	3,430	6,910	14,800	15,700	6,140	3,610	4,530	4,230	3,420
24	2,930	2,940	3,470	6,910	15,200	15,500	5,740	3,750	4,460	4,220	3,350
25	2,950	2,930	3,500	6,910	16,300	15,200	5,350	3,800	4,320	4,240	3,320
26	2,920	2,930	3,450	7,070	16,400	15,000	5,200	3,830	4,210	4,380	3,200
27	2,890	2,950	3,390	7,120	15,900	14,600	5,150	3,870	4,150	4,410	3,160
28	2,870	2,970	3,350	6,700	16,200	14,000	4,990	3,990	4,190	4,320	3,230
29	2,850	3,310	3,390	6,330	16,800	13,200	4,960	4,040	4,280	4,280	3,260
30	2,800		3,450	6,220	17,800	12,500	5,060	4,000	4,180	4,290	3,280
31	2,890		3,460		18,400		4,880	3,980		4,260	

APPENDIX E

Persigo WWTP Historical Effluent Flows (October – January)

Persigo Effluent Flows (MGD)

2014	October	November	December	January
30 Day Average	8.66	7.91	7.74	7.45
30 Day Maximum	9.80	8.78	8.4	7.82
30 Day Minimum	8.26	7.40	6.45	6.67

2015	October	November	December	January
30 Day Average	8.91	8.43	7.97	7.72
30 Day Maximum	10.07	9.73	8.57	8.15
30 Day Minimum	7.98	7.62	6.91	7.24

2016	October	November	December	January
30 Day Average	9.33	8.60	8.39	7.87
30 Day Maximum	10.09	9.51	9.18	8.84
30 Day Minimum	8.57	7.34	7.75	7.05

2017	October	November	December	January
30 Day Average	8.98	8.28	8.02	8.47
30 Day Maximum	9.67	8.96	8.87	9.72
30 Day Minimum	8.32	7.60	5.35	7.72

2018	October	November	December	January
30 Day Average	---	---	---	7.80
30 Day Maximum	---	---	---	8.13
30 Day Minimum	---	---	---	7.44

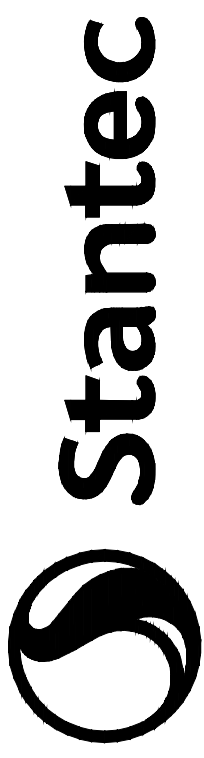

CITY OF GRAND JUNCTION / MESA COUNTY
PERSIGO WASH WASTEWATER TREATMENT PLANT

PERSIGO WASTEWATER TREATMENTS
DIFFUSER OUTFALL IMPROVEMENTS
FINAL CONSTRUCTION DRAWINGS

JANUARY 2018

Project Number: 205305055



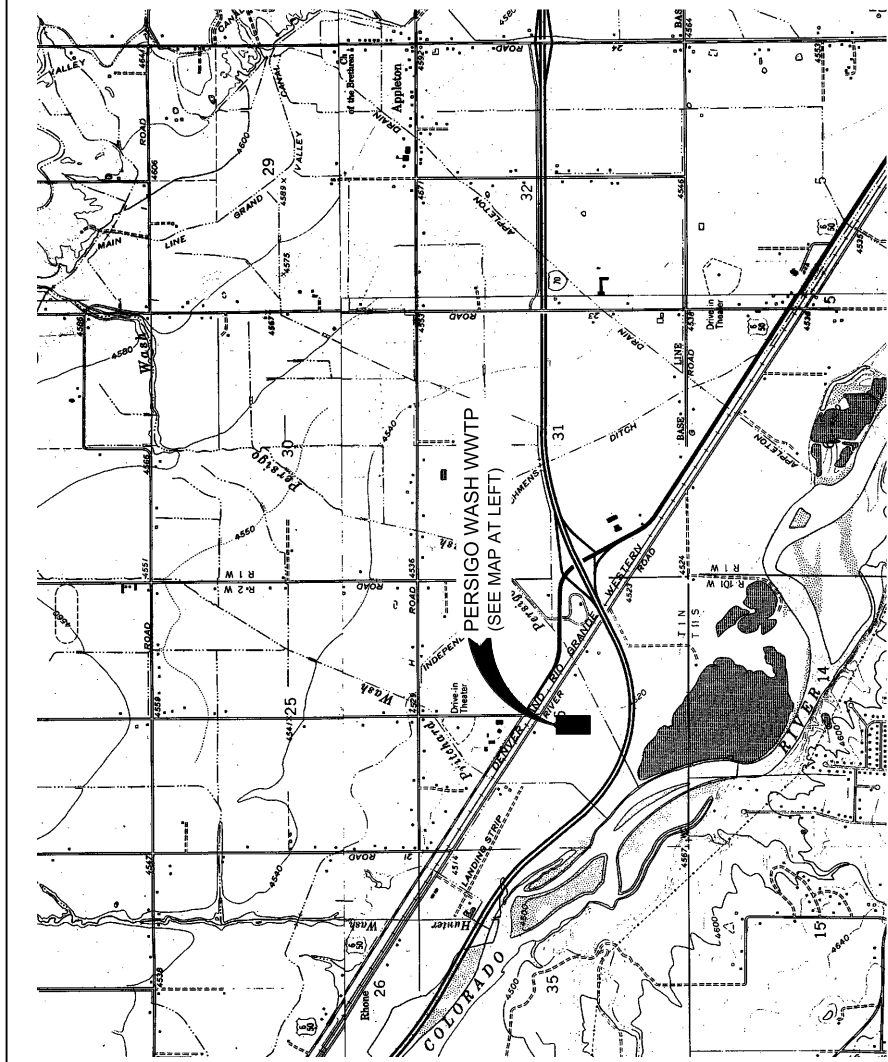

PROJECT LOCATION MAP
 N.T.S.

DRAWING INDEX

REVISION/ISSUE	SHEET NUMBER	DRAWING NUMBER	DRAWING TITLE
GENERAL			
	1	G001	COVER SHEET
	2	G002	PROJECT LOCATION MAP, GENERAL NOTES, AND LIST OF DRAWINGS
	3	G003	DRAWING ABBREVIATIONS LEGENDS AND SYMBOLS
	4	G100	PROJECT EASEMENT PLAN
CIVIL			
	5	C100	OVERALL SITE PLAN AND PROJECT CONTROL MAP
	6	C101	EROSION CONTROL PLAN
	7	C102	EROSION CONTROL NOTES SHEET 1 OF 3
	8	C103	EROSION CONTROL NOTES SHEET 2 OF 3
	9	C104	EROSION CONTROL NOTES SHEET 3 OF 3
	10	C200	OUTFALL PIPELINE PLAN AND PROFILE STA. 10+00.00 TO 20+83.66
	11	C301	OUTFALL PIPELINE PLAN AND PROFILE STA. 20+83.66 TO 30+00.00
	12	C300	PIPELINE SECTIONS
	13	C500	DIFFUSER DETAILS
	14	C501	PIPE AND MANHOLE DETAILS
	15	C502	DETAILS
	16	C503	EROSION CONTROL DETAILS
STRUCTURAL			
	17	S100	EXISTING EFFLUENT BOX STRUCTURAL PLAN, SECTIONS AND DETAILS

- GENERAL NOTES:**
- THE CONTRACTOR SHALL NOTIFY THE CITY OF GRAND JUNCTION AT LEAST 48 HOURS PRIOR TO THE START OF CONSTRUCTION.
 - THE CONTRACTOR SHALL BE RESPONSIBLE FOR LOCATING AND VERIFYING ALL EXISTING UTILITIES THAT WILL BE AFFECTED PRIOR TO THE START OF CONSTRUCTION. ANY DISCREPANCIES SHALL BE IMMEDIATELY BROUGHT TO THE ATTENTION OF THE ENGINEER.
 - ELEVATIONS, DIMENSIONS FOR THE EXISTING PIPING SHOWN ON THE DRAWINGS ARE APPROXIMATE ONLY AND SHOULD BE VERIFIED IN THE FIELD BY THE CONTRACTOR.
 - THE CONTRACTOR SHALL OBTAIN, AT HIS EXPENSE, ALL PERMITS WHICH ARE NECESSARY TO PERFORM THE PROPOSED WORK.
 - EXISTING WASTEWATER TREATMENT SYSTEM SHALL REMAIN ACTIVE FOR THE DURATION OF THE PROJECT. COORDINATE WITH THE OWNER IF INTERFERENCE OR INTERRUPTION WITH THE EXISTING WASTEWATER TREATMENT SYSTEM IS NEEDED FOR CONSTRUCTION.
 - SITE ACCESS ON THE PLANT SIDE SHALL BE FROM THE MAIN ENTRANCE VIA THE MAIN ACCESS ROAD. ACCESS SOUTH OF I-70 SHALL BE AS SHOWN ON DWG. G100.
 - EFFORTS TO SHOW EXISTING PIPING IN THEIR APPROPRIATE LOCATION HAVE BEEN MADE AND ARE SHOWN HEREIN. CONTRACTOR SHALL VERIFY THE LOCATION OF ALL UNDERGROUND UTILITIES.

CONTACT INFORMATION:
 DESIGN ENGINEER
 COLIN HAGGERTY, P.E.
 STANTEC
 2000 S. COLORADO BLVD. SUITE 2-300
 DENVER CO, 80222
 (303) 285-4594

OWNER:
 LEE COPPER, P.E.
 GRAND JUNCTION
 250 N. 5TH STREET
 GRAND JUNCTION CO, 81501
 (970) 256-4155

URS FISH & WILDLIFE SERVICE:
 BARB OSKUNDSON, BIOLOGIST
 445 WEST GUNNISON AVE., SUITE 240
 GRAND JUNCTION CO, 81501
 (970) 628-7189

CDOT:
 JOEL BERSCHAUER
 UTILITY AND SPECIAL USE PERMIT COORDINATOR
 222 SOUTH 6TH STREET ROOM 100
 GRAND JUNCTION CO, 81501
 (970) 683-6288

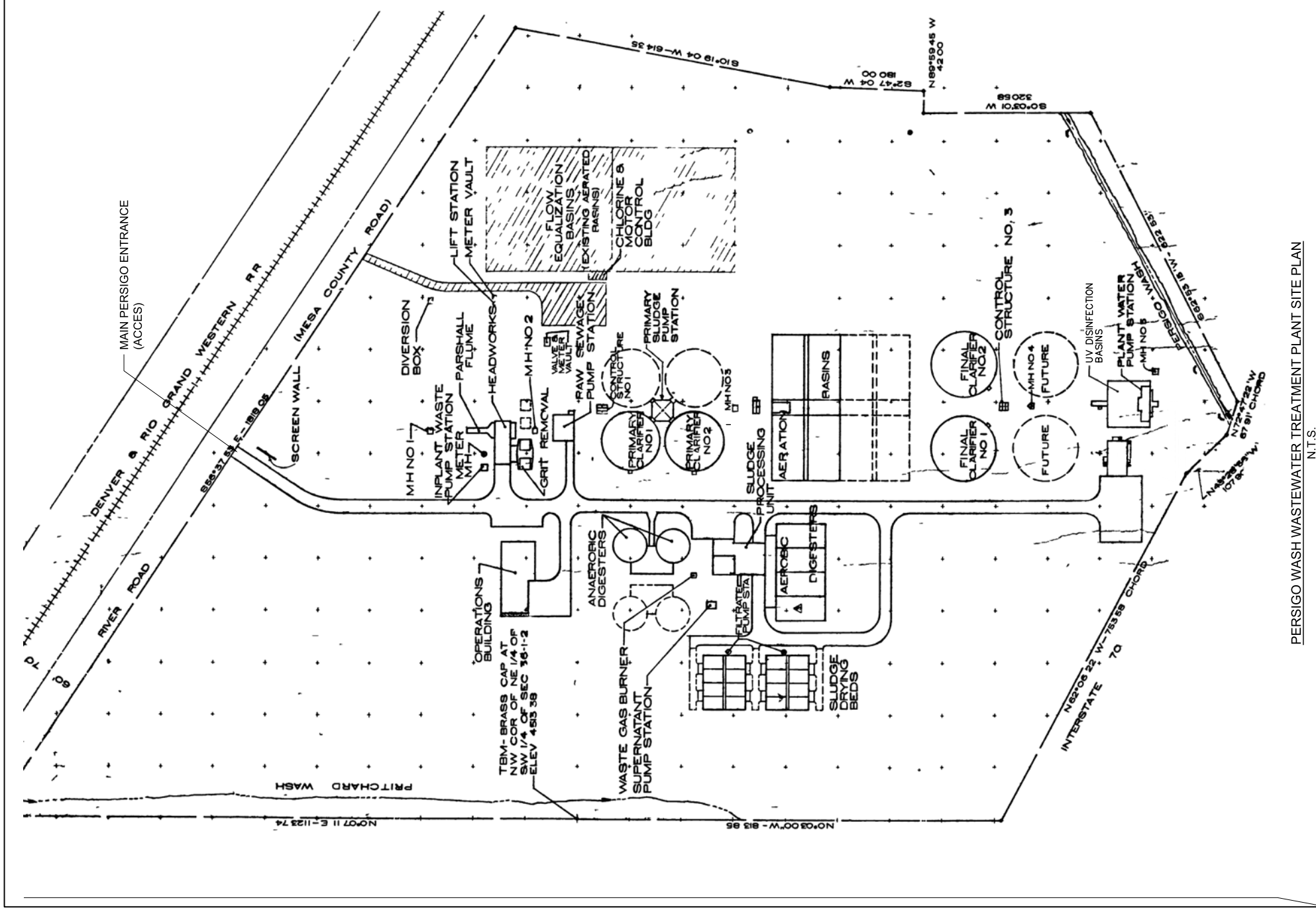
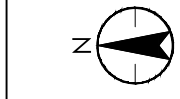

PERSIGO WASH WASTEWATER TREATMENT PLANT SITE PLAN
 N.T.S.



Revision	By	App'd	Y/M/D
	SH	CH	18.01.03
	SH	CH	17.05.03
	SH	CH	16.08.31
	SH	CH	16.08.31
	SH	CH	16.08.31

Item	Pay Item	Description	Qty Unit	Initial Cont.	Interim Cont.	Permanent Stabilization	Total Quantity
53P	208-00104	Sweeping (Sediment Removal)	LS				
53P	208-00107	Removal of Trash	LS				
53P	208-00207	Erosion Control Management (ECM)	LS	1			
53P	208-00300	Temporary Berm	LF				
53P	208-00301	Temporary Diversion (Coffer Dam)	LF	500			
53P	208-00520	Temporary Stream Crossing	LS	1			
53P	212-00006	Seeding (Native)	Acres	4.1			
53P	212-00007	Seeding (Temporary)	Acres				
53P	212-00013	Soil Conditioning	Acres	4.1			
53P	213-00002	Hydraulic Mulching	Acres	4.1			
53P	213-00061	Mulch Tackifier	LB				
53P	213-00150	Bonded Fiber Matrix	Acres				
53P	213-00151	Bonded Fiber Matrix	LB				
53P	214-00000	Landscaping Maintenance	LS	1			
53P	216-00001	Turf Reinforcement Mat (Class 1)	SY				
53P	217-00000	Herbicide Treatment	SY				
53P	607-11525	Fence (Plastic)	LF				
53P	700-70380	Erosion Control	FA				

*It is anticipated that additional BMP/Control Measures and BMP/Control Measure quantities not shown on the SWMP Site Maps shall be required on the project for unforeseen conditions and replacement of items that are beyond their useful service life, see CDDJ subsection 208.03 and 208.04. Quantities for all BMP/Control Measures shown above are estimates and have been increased for unforeseen conditions and normal BMP/Control Measure maintenance. The contractor shall verify and be responsible for all dimensions, DO NOT scale the drawing. Any errors or omissions shall be reported to Stantec without delay. The copyright to all designs and drawings are the property of Stantec. Reproduction is prohibited.

(April 2014)

Table 1. Federally-Listed, Proposed or Candidate Species Potentially Occurring Within Mesa County, CO

Species and Status	Habitat	Area of Influence/Project Site Suitable Habitat	Species Documented
<i>Daboquila placida</i> * (Threatened)	PLANTS Sparsely vegetated, steep slopes in shrublands, brown, gray, or red clay on Atwell Gulch and Shire Members, Wasatch Formation. Soils often have large cracks because of the high shrink-swell potential of the clays; desert shrubland with four-wing saltbush, alkali-sage, greasewood, ironwood, and shrublands squirreltail and Indian ricegrass, including upward into scattered junipers, 4,700-6,300 ft.	No	No
<i>Colorado hoodless cactus</i> * (Threatened)	Rocky hills, mesa slopes, and alluvial benches in soil desert shrub communities, often with well-developed interlocking cracks occur in desert shrublands with the desert juniper, black sagebrush, Indian ricegrass growing upward into big sagebrush and sagebrush/physion-juniper, 4,500-6,000 ft.	No	No

* These species were considered but dropped from further detailed analysis because they were not detected during surveys conducted for this project and are not known to occur within the project vicinity and/or would not be affected by project development.

Table 1. Federally-Listed, Proposed or Candidate Species Potentially Occurring Within Mesa County, CO

Species and Status	Habitat	Area of Influence/Project Site Suitable Habitat	Species Documented
Gambusia sage-grouse* (Threatened)	BIRDS Broad, continuous big sagebrush habitat on flat or gently sloping terrain south of the Colorado River.	No	No
Mexican spotted owl* (Threatened)	Old growth forests and extensive rocky canyon habitat with cliffs.	No	No
Yellow-billed Cuckoo (Threatened)	Old growth riparian woodlands (cottonwood galleries) with dense understorey.	Yes	Yes

Permit-560



12. TABULATION OF STORWATER QUANTITIES

- A. BMP/Control Measure sediment removal and disposal shall be paid for as: 208 Removal and Disposal of Sediment (Equipment) and 208 Removal and Disposal of Sediment (Labor). All other BMP/Control Measure maintenance shall be included in the cost of the BMP/Control Measure.
- B. It is estimated that 40 hours of labor may be required for miscellaneous erosion control work as directed by the Engineer. Work shall be paid for as 203 Labor.
- C. Establishment of seeded areas shall be paid for as: 212 Seeding (Native) This shall include mowing, weed control, reseeding/mulch/tackifier.

Spec	Pay Item	Description	Qty Unit	Initial Cont.	Interim Cont.	Permanent Stabilization	Total Quantity
53P	203-00230	Laborer	Hour	40			
53P	207-00205	Topsoil	CY	2500			
53P	207-00210	Stockpile topsoil	CY	2500			
53P	208-00004	5ft Berm	LF				
53P	208-00013	Erosion Log Type 1 (20 inch)	LF				
53P	208-00020	5ft fence	LF	100			
53P	208-00033	Sediment trap	Each				
53P	208-00046	Pre-labeled Concrete Washout Structure	Each	2			
53P	208-00051	Storm Drain Inlet Protection (Type I)	LF	20			
53P	208-00070	Vehicle Tracking Pad	Each	2			
53P	208-00103	Removal and Disposal of Sediment (Labor)	Hour				
53P	208-00105	Removal and Disposal of Sediment (Equipment)	Hour				

13. BIOLOGIC IMPACTS

- A. ENVIRONMENTAL IMPACTS
 - 1. Wetland impacts
 - 2. Stream impacts
 - 3. Threatened and Endangered Species: Federally listed, candidate and proposed species potentially occurring in within the proposed action area in Mesa County, Colorado (Table 1) were reviewed (USFWS 2015). A Biological Assessment accompanies this PCN for submittal to U.S. Fish and Wildlife Service.

Table 1. Federally-Listed, Proposed or Candidate Species Potentially Occurring Within Mesa County, CO

Species and Status	Habitat	Area of Influence/Project Site Suitable Habitat	Species Documented
Gambusia sage-grouse* (Threatened)	BIRDS Broad, continuous big sagebrush habitat on flat or gently sloping terrain south of the Colorado River.	No	No
Mexican spotted owl* (Threatened)	Old growth forests and extensive rocky canyon habitat with cliffs.	No	No
Yellow-billed Cuckoo (Threatened)	Old growth riparian woodlands (cottonwood galleries) with dense understorey.	Yes	Yes
Colorado pikeminnow (Endangered)	Colorado River, downstream from Rifle, Colorado.	Yes	Yes
Razorback sucker (Endangered)	Colorado River, downstream from Rifle, Colorado.	Yes	Yes
Bonytail (Endangered)	Lower Colorado River, primarily Grand Valley and to the west.	Yes	Yes
Humpback chub (Endangered)	Lower Colorado River, primarily Grand Valley and to the west.	Yes	Yes
Greenback cutthroat trout* (Threatened)	Cold water streams, Grand Mesa area including Cuckee Creek on the north side of Battlement Mesa.	No	No

- 1. M-Standards have been included along with Standard BMP narratives. If a Non-Standard BMP will be used or the standard narrative does not apply, the SWMP Administrator shall write a Non-Standard BMP narrative, place an "X" in the column and complete a Non-Standard BMP Specification and Narrative for the SWMP notebook.
- 2. The SWMP Administrator shall place an "X" in the column in the SWMP notebook when the BMP/Control Measure has been installed.
- 3. Place an "X" in the column in the SWMP notebook when the SWMP Administrator has approved the BMP/Control Measure during construction. These BMP/Control Measures are not commonly used in the SWMP notebook.
- 4. Place an "X" in the column in the SWMP notebook when the SWMP Administrator has approved the BMP/Control Measure prior to or during construction and placed on SWMP Note.

STRUCTURAL BMP/Control Measures that may be potentially used on the project for erosion and sediment control; practices may include, but are not limited to:

APPLICATION BMP/CONTROL MEASURE	NARRATIVE	M-STANDARD/NON-STANDARD	IN USE ON SITE	BMP/CONTROL MEASURE TO BE LOCATED BY SWMP ADMINISTRATOR	RE-CONSTRUCTION	FIRST/INITIAL CONSTRUCTION ACTIVITIES	INTERIM CONSTRUCTION ACTIVITIES	PERMANENT STABILIZATION
PROTECTION OF EXISTING WETLANDS	Fence (plastic) shall be placed in combination with erosion logs to prevent encroachment of construction traffic and sediment into state waters prior to start of construction activities. Fence (plastic) shall be placed adjacent to the wetlands; erosion logs shall be placed between the plastic fence and disturbance area. Logs shall be placed to direct flows away from or filter water running into wetlands from disturbance area.					X	X	
PROTECTION OF EXISTING TREES/ANDSCAPING	Fence (plastic) shall be used in areas indicated in the plans to prevent encroachment of construction traffic and sediment for the protection of mature trees and/or existing landscaping prior to start of construction activities.					X	X	
STOCKPILE PROTECTION	Placed within specified distance, in accordance with CDDJ subsection 208.05, from top of sediment around stockpiles. Aggregate bags are easily moved and replaced for access during the work day. Place prior to start of stock pile. Increase control as stock pile increases in size.	M-209					X	
EROSION LOGS	Erosion logs shall be used to capture sediment and protect and delineate undisturbed areas. *Can be used in stockpile layout for salvage.	M-208				X	X	
PERMEABLE CONTROL	Placed prior to construction commencing to address potential run-on water from off site, and to divert around disturbed area. *Can be used to stockpile layout for salvage.	M-205				X	X	
SEEDING CONTROL	Placed on the contour of a slope to contain and slow down construction runoff. Place prior to start of construction disturbance.	M-206				X	X	
CONCRETE WASHOUT	Construction control, used for waste management of concrete and concrete equipment cleaning. Place prior to start of concrete activities.	M-208				X	X	
VEHICLE TRACKING PAD	Source control, placed to prevent tracking of sediment from disturbed area to offsite surfaces. Place prior to start of construction disturbance.	M-208				X	X	
SWEEPING	Source control, used to remove sediment tracked onto paved surfaces and to prevent sediment from entering storm water system. Sweep only on or at the end of the construction site to remove. Sweeping shall not be permitted.					X	X	
DEWATERING	Should be done in such a manner to prevent potential pollutants from entering state water.					X	X	
TEMPORARY STREAM CROSSING	Constructed over stream of drainage to prevent discharge of pollutants from construction equipment into water.					X	X	
CLEAN WATER DIVERSION	Placed to divert clean surface or ground water around disturbance area to prevent it from mixing with construction runoff.					X	X	

NON-STRUCTURAL BMP/Control Measures that may be potentially used on the project for erosion and sediment control; practices may include, but are not limited to:
Erosion control devices are used to limit the amount of soil loss on site.
Sediment control devices are used to capture sediment on the project site.
Construction controls are BMP/Control Measures related to construction access and staging.
BMP/Control Measure locations are indicated on the SWMP site map.

APPLICATION BMP/CONTROL MEASURE	NARRATIVE	M-STANDARD	IN USE ON SITE	BMP/CONTROL MEASURE TO BE LOCATED BY SWMP ADMINISTRATOR	RE-CONSTRUCTION	FIRST/INITIAL CONSTRUCTION ACTIVITIES	INTERIM CONSTRUCTION ACTIVITIES	PERMANENT STABILIZATION
VEGETATIVE BUFFER STRIP	Filter sediment laden runoff from disturbance area. Area to be identified on SWMP prior to construction starting.					X	X	X
LANDFORM	Existing landforms may be used as a BMP/Control Measure if they prevent sediment from entering or leaving the disturbance area. If a landform directs flow of water to a concentrated outlet point, the outlet point shall be protected to prevent erosion. Area to be identified on SWMP prior to construction starting.					X	X	X
SURFACE ROUGHENING / GRADING	Prior to embankment work commencing, existing topsoil shall be exposed to a depth of 4 inches, and placed in stockpiles or windrows. Upon completion of slope work/finishing grading (less 4 inches), topsoil shall be evenly distributed over embankment to a depth of 4 inches.					X	X	X
SOIL RETENTION BLANKET (SRB)	Temporary stabilization of disturbance and to minimize wind and erosion.					X	X	X
MULCH/MULCH TACKIFIER	Temporary stabilization used for over wintering of disturbance or used to control erosion for areas scheduled for future construction.					X	X	X
SPRAY-ON MULCH BLANKET	Not to be used in areas of concentrated flows, i.e. ditch lines. To be used in combination with surface roughening for temporary stabilization of disturbed soils, when work is temporarily halted and as approved by the Engineer. May be used as surface cover for temporary, topsoil stockpiles.					X	X	X
SOIL RETENTION BLANKET (SRB)	Temporary or Final Stabilization placed as a surface cover for erosion control and/or seeding establishment. To be installed as temporary surface cover when work is temporarily halted and as approved by the Engineer.					X	X	X
TURF REINFORCEMENT MAT (TRM)	Final Stabilization of disturbance and to reduce runoff and control erosion on disturbed areas.	M-216				X	X	X
OTHER	Final Stabilization of disturbance and to reduce runoff and control erosion on disturbed areas. Placed in permanent or on slope for erosion control, channel flow and seeding establishment.	M-216				X	X	X

Table 1. Federally-Listed, Proposed or Candidate Species Potentially Occurring Within Mesa County, CO			
Species and Status	Habitat	Area of Influence/Project Site	
		Suitable Habitat	Species Documented
FISH			
Colorado pikeminnow (<i>Ptychocheilus icetae</i>) Endangered	Colorado River, downstream from Rifle, Colorado.	Yes	Yes
Razorback sucker (<i>Xylocheilus texanus</i>) Endangered	Colorado River, downstream from Rifle, Colorado.	Yes	Yes
Bonytail (<i>Cilia elongata</i>) Endangered	Lower Colorado River, primarily Grand Valley and to the west.	Yes	Yes
Humpback dhab (<i>Gila cypha</i>) Endangered	Lower Colorado River, primarily Grand Valley and to the west.	Yes	Yes
Greenback cutthroat trout* (<i>Oncorhynchus clarkii stansburii</i>) Threatened	Cold water streams, Grand Mesa area including Cache Creek on the north side of Battlement Mesa.	No	No
PLANTS			
DeBeque phacelia* (<i>Phacelia nitratica</i>) Threatened	Sparsely vegetated, steep slopes in chocolate-brown, gray, or red clay on Atwell Gulch and Shire Members, Wasatch Formation. Soils often have large cracks because of the high shrink-swell potential of the clays; desert shrubland with four-wing silibush, shadscale, greasewood, brown wing silibush, bottlebrush squirreltail and Indian snakeroot, bottlebrush squirreltail and Indian ricegrass, grading upward into scattered junipers; 4,700-6,200 ft.	No	No
Colorado hookless cactus* (<i>Sclerocactus glaucus</i>) Threatened	Rocky hills, mesa slopes, and alluvial benches in salt desert shrub communities; often with well-formed microbialite crusts; can occur in dense cheatgrass; with shadscale, galleta grass, black sagebrush, Indian ricegrass grading upward into big sagebrush and sagebrush/pinyon-juniper; 4,500-6,000 ft.	No	No

* These species were considered but dropped from further detailed analysis because they were not detected during surveys conducted for this project and are not known to occur within the project vicinity and/or would not be affected by project development.

4. If YES to any of the above items, are any permits required or additional actions needed (A04, etc.)
 404 permit has been approved. 3PK-2016-20171

14. NOTES

A) Wetland Top Soil Handling Techniques
 The top 12 inches of wetland topsoil containing plant root stock and seed will be stripped from the impacted wetlands and redistributed upon completion of the pipeline installation (CNAP 1998). Wetland topsoil will be handled with care by avoiding compaction of undisturbed or stockpiled soils to protect the rhizomes, seed, and propagule sources. If wetland topsoil will need to be temporarily stored, it will be stockpiled in linear rows no greater than 3 feet high and 3 feet wide and not allowed to dry out (NRCS 2008). Covering the stockpiles may be necessary to keep the soil moist and prevent noxious weed infestations.

It is expected that salvaged topsoil will yield a valuable seed source and root stock and should establish quickly. Seeding of wetland species should only be used as a supplemental revegetation technique to the salvaged wetland top soil plant source.

B) Re-Fueling
 A lined re-fueling station will be established a minimum of 100 feet from the water's edge of the Colorado River and Persigo Wash. Adequate spill response equipment will be present at the refueling station. Gas will be transported in ANSI approved containers. Funnels will be used to re-fill tanks and wind blocks created in re-fueling under windy conditions.

C) Site Re-establishment

- Prior to delivery to the site, equipment will be cleaned of soils remaining from previous construction sites which may be contaminated with noxious weeds.
- Equipment and material handling will be done on established sites to reduce the area and extent of soil compaction.
- Top soil, where present, will be segregated from deeper soils and replaced as top soil on the final grade, a process known as five topsoil handling. Wetland topsoil will be stored separately from upland top soil. (See the below wetland soil handling techniques)
- If stored longer than one growing season, upland topsoil stockpiles should be seeded with non-invasive sterile hybrid grasses for stabilization.
- Soil disturbance by heavy equipment in wetland areas will be minimized by using mats and other appropriate measures.
- No temporary fills will be stored in wetland areas. Native material removed during trench excavation from wetland areas will be stored in an upland location, detailed in the erosion control plan. However, if it is deemed necessary to place temporary fill material into wetland areas during the construction process, a horizontal marker will be used to delineate the existing ground elevation in order to ensure all temporary fill material is removed and the wetland is returned to its original grade.
- Cut-off collars will be placed on all wetland and stream crossings to prevent back washing (seed vector) and to ensure that soil moisture conditions are not impacted after construction so that native plants can re-establish from the existing seed bank.
- All exposed soils and fill material below the ordinary high water mark will be permanently stabilized at the earliest practicable date.
- After construction wetland soils will be spread 6 inches to 12 inches deep in areas where wetlands were disturbed during construction.
- After construction, disturbed areas (with the exception of wetland areas) will be immediately reseeded with the seed mix provided in the BA.

- Flows in the Colorado River and Persigo Wash will not be impeded and low flows will be maintained during project construction. A soil coffer dam would be installed in the Colorado River to direct flows away from the construction area. To maintain low flows through Persigo Wash while the temporary access road is in use, a 54" CMP will be installed into the wash and the road crossing constructed above.
- All efforts to minimize restriction and acceleration of water from the installation and removal of the coffer dam into the Colorado River and the 54" CMP into Persigo Wash will be made.
- The pre-construction course, conditions, capacity, and location of the Colorado River or Persigo Wash will not be altered by the project.
- Side slopes of Persigo Wash will be graded to match the existing slopes upon removal of the 54" CMP.



Revision	By	Appd.	Y/M/D
	SHH	CRH	16.08.31
	SHH	CRH	17.05.03
	SHH	CRH	18.01.03
	SHH	CRH	17.05.03
	SHH	CRH	16.08.31
	SHH	CRH	16.08.31

Revision	By	Appd.	Y/M/D
	SHH	CRH	16.08.31
	SHH	CRH	17.05.03
	SHH	CRH	18.01.03
	SHH	CRH	17.05.03
	SHH	CRH	16.08.31
	SHH	CRH	16.08.31

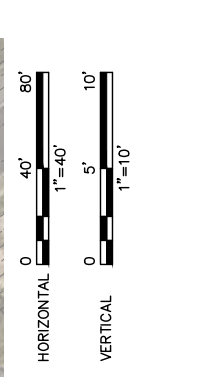

- NOTES:
- HGL BASED ON 100 YR. TAILWATER OF 4517 IN THE COLORADO RIVER. ELEVATION OF HGL DOES NOT REFLECT ELEVATION OF RIVER DURING CONSTRUCTION.
 - HGL SHOWN ONLY REFLECTS ELEVATION USED FOR DESIGN OF OUTFALL.
 - ALL WORK MUST REMAIN OUTSIDE CDDOT ROW AT ALL TIMES WITH THE EXCEPTION OF TRENCHLESS CONSTRUCTION.
 - ALL MANHOLES SHALL HAVE LOCKING LIDS. LIDS SHALL BE NEENAH R-1574 OR APPROVER EQUAL.

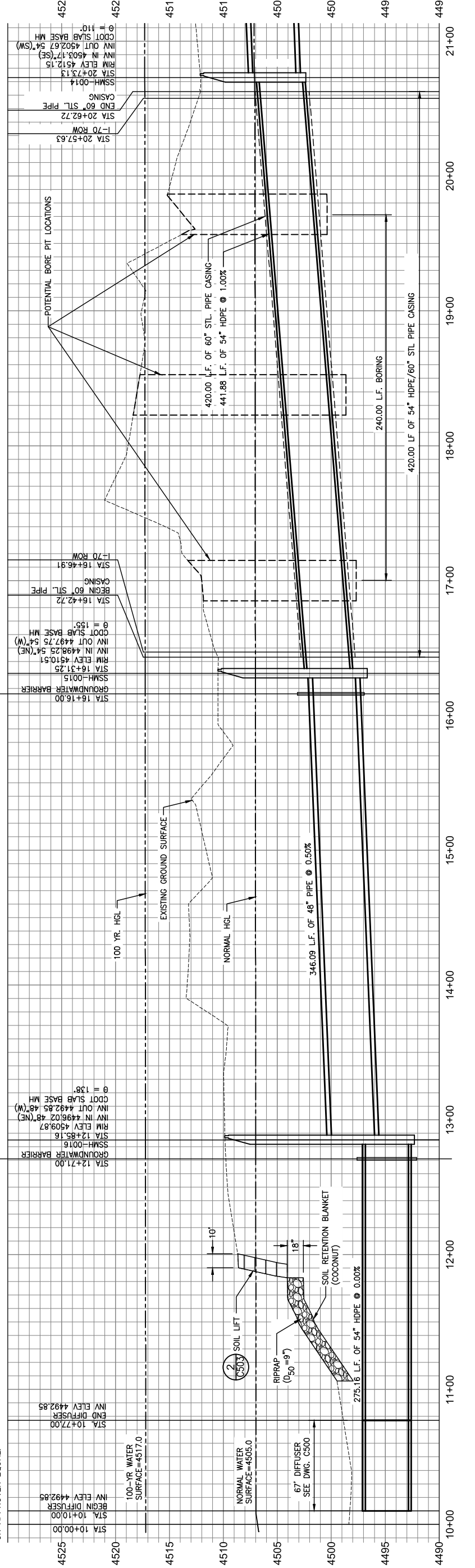

Client/Project: CITY OF GRAND JUNCTION / MESA COUNTY
 Permit-Seq: PERISGO WASTEWATER TREATMENT PLANT
 DIFFUSER OUTFALL IMPROVEMENTS
 OUTFALL PIPELINE PLAN AND PROFILE
 STA. 10+00.00 TO 20+83.66

Project Number: 2053030555
 File Name: 0055-C201.dwg
 S.L.H.: D.S., C.P.H., 18.01.02
 D.W.: C.H.G., D.B.G., YAMALDD
 Drawing No. C200
 Revision Sheet

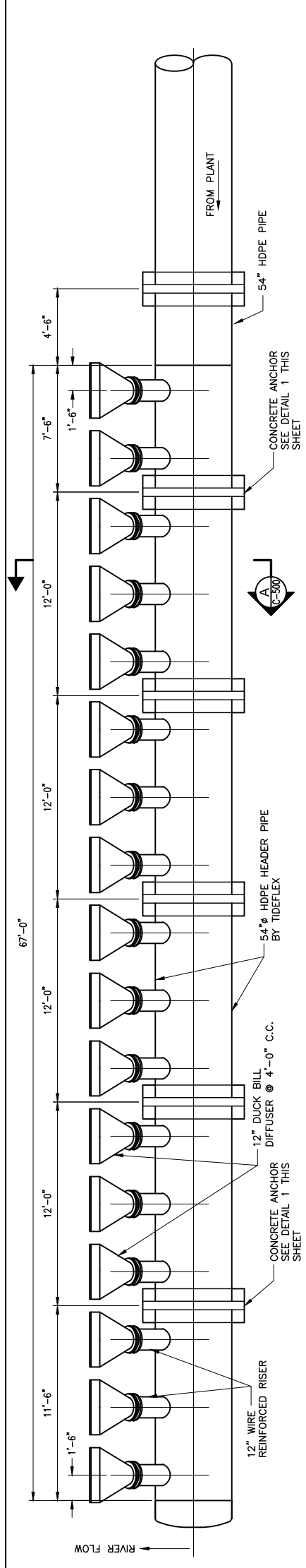

PLAN VIEW
 1/4" = 1'-0"

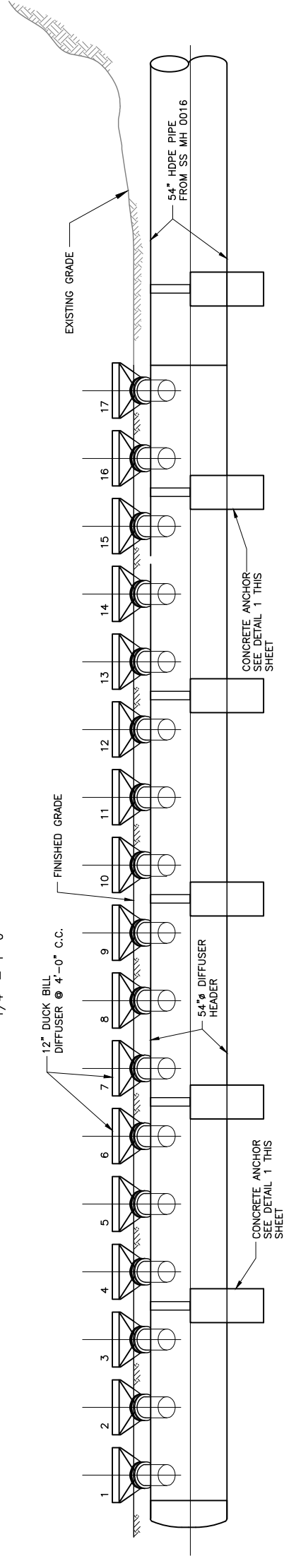

ELEVATION VIEW
 1/4" = 1'-0"

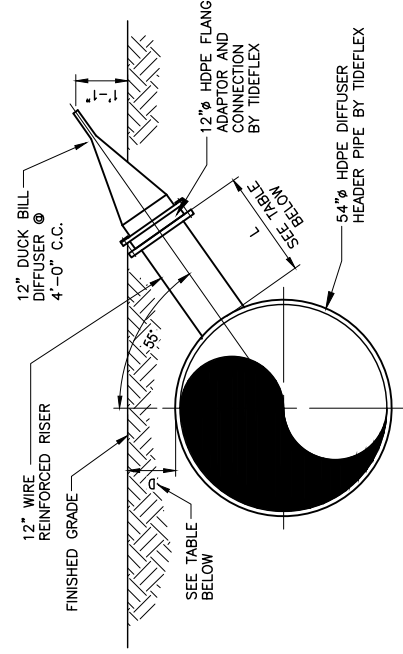

A SECTION
 1/2" = 1'-0"

Diffuser ID	Diffuser Depth "D" (ft)	Diffuser Extension "L" (ft)
1	0.5	1.64
2	0.5	1.64
3	0.5	1.64
4	0.5	1.64
5	0.5	1.64
6	0.5	1.64
7	0.5	1.64
8	0.5	1.64
9	0.5	1.64
10	0.5	1.64
11	0.5	1.64
12	0.5	1.64
13	0.6	1.78
14	0.7	1.92
15	0.8	2.06
16	0.9	2.20
17	1	2.35

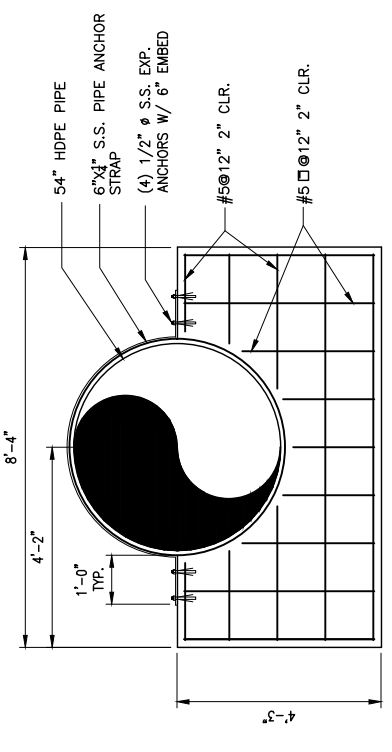

FRONT VIEW

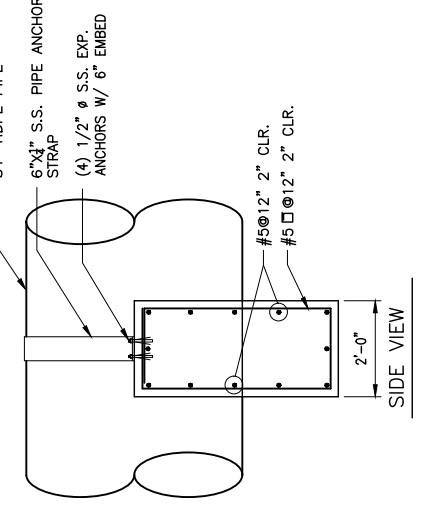

SIDE VIEW

1 DETAIL
 CONCRETE ANCHOR BLOCK
 N.T.S.

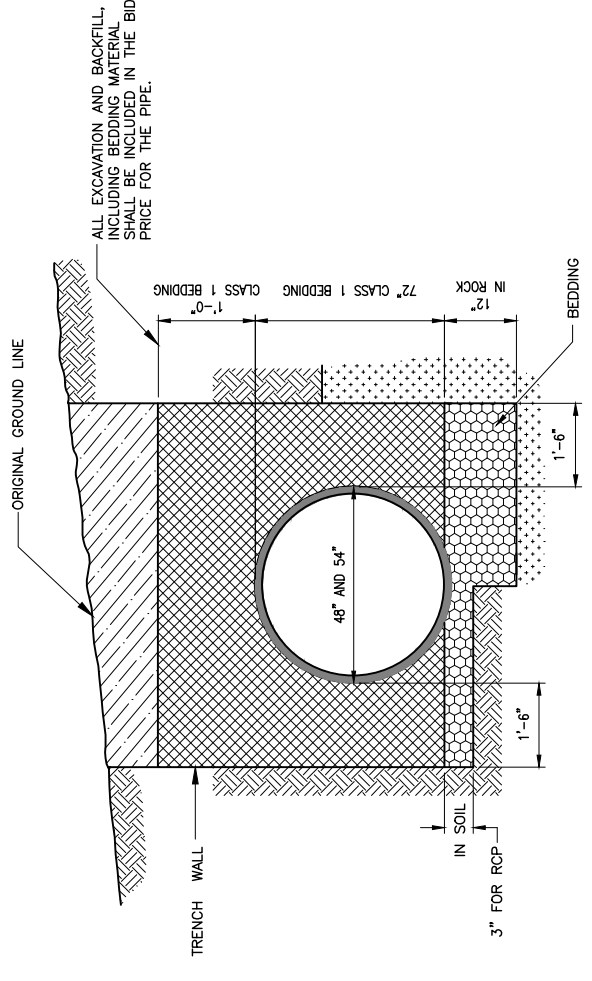

2 DETAIL
 PIPE IN TRENCH
 N.T.S.

• THE BEDDING MATERIAL FOR RIGID PIPE IN SOIL SHALL BE 3 IN. OF LOOSE STRUCTURE BACKFILL (CLASS 1). BEDDING IS NOT REQUIRED FOR FLEXIBLE PIPE IN SOIL. BEDDING MATERIAL FOR RIGID OR FLEXIBLE PIPE IN ROCK SHALL BE 12 IN. OF LOOSE STRUCTURE BACKFILL, CLASS 1.

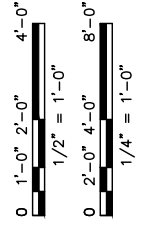

Revision	By	Appd.	Issued
	SLH	YY/MK/DD	
	CRH	16/08/31	A DESIGN REVIEW APPLICATION
	SLH	17/05/03	B FINAL CONSTRUCTION DRAWINGS
	CRH	18/01/03	C FINAL SET DRAWINGS

Client/Project: CITY OF GRAND JUNCTION / MESA COUNTY
 Permit-Seed
 PERSIGO WASTEWATER TREATMENT PLANT
 DIFFUSER OUTFALL IMPROVEMENTS
 EXISTING EFFLUENT BOX STRUCTURAL
 PLAN, SECTIONS AND DETAILS



Project Number: 205305055
 File Name: 090553100.dwg

S.L.H.	D.S.	C.R.H.	B.O.D.D.
Drawn	Checked	Design	Final Review

Drawing No. S100
 Revision Sheet
 C 17 of 17

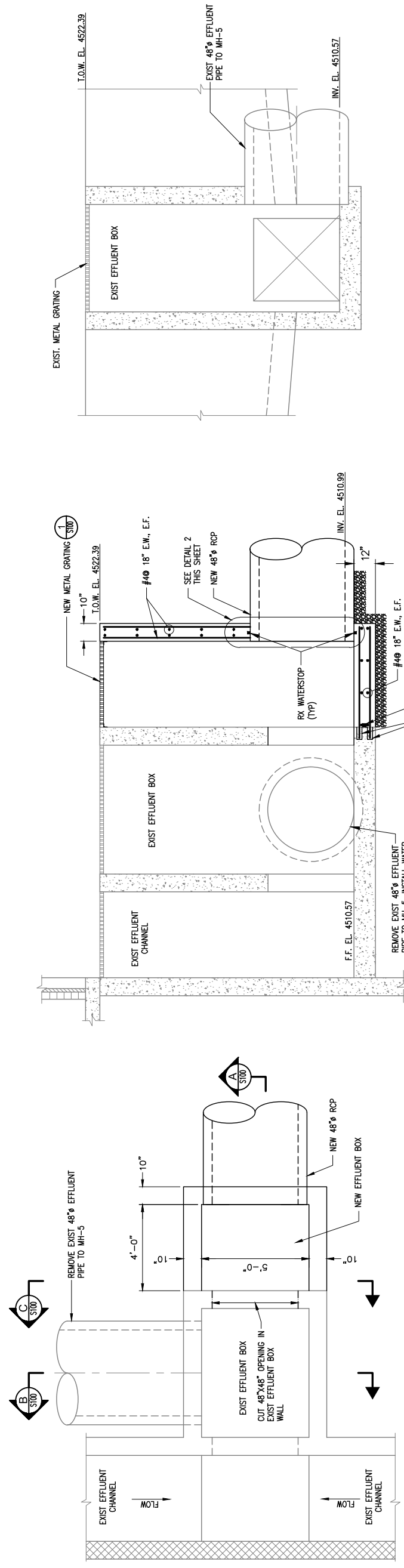

EFFLUENT BOX PLAN
 3/8" = 1'-0"

A SECTION
 3/8" = 1'-0"

B SECTION
 3/8" = 1'-0"

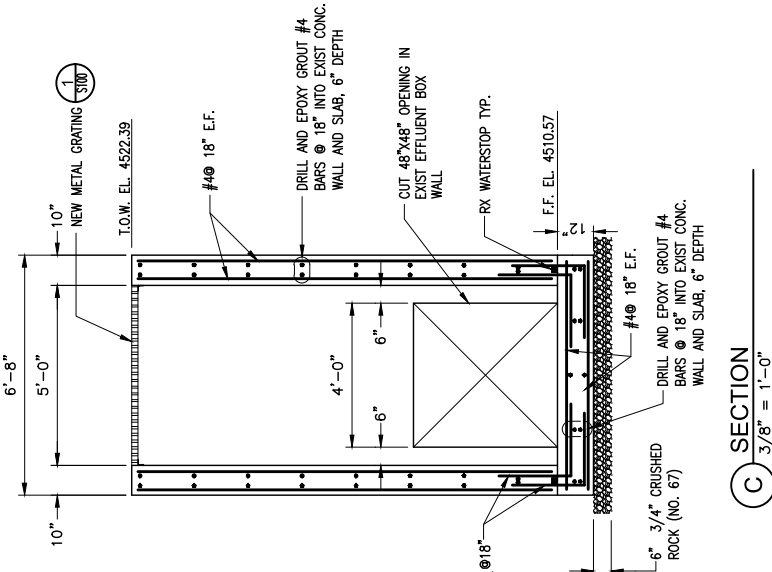

C SECTION
 3/8" = 1'-0"

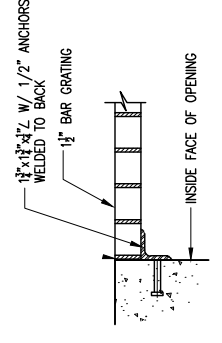

1 DETAIL
 N.T.S.

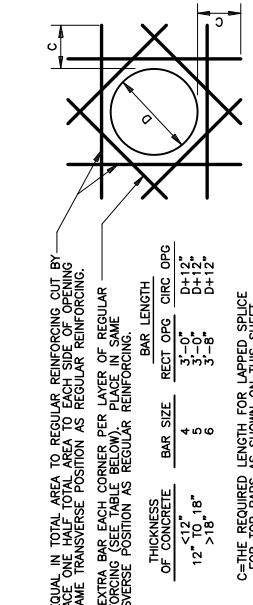

2 DETAIL
 N.T.S.

CONCRETE COVER FOR REINFORCEMENT		MINIMUM COVER
LOCATION		
UNFORMED SURFACES ADJACENT TO EXCAVATION		3"
FORMED OR TOP SURFACES EXPOSED TO WEATHER OR SUBJECT TO SUBMERGENCE IN CONTACT WITH EARTH, INCLUDING STIRRUPS, TIES OR SPIRALS		2"
OTHER LOCATIONS		
BARS IN BEAMS OR GIRDERS, INCLUDING STIRRUPS AND COLUMN SPIRALS OR TIES		1 1/2"
SLABS, WALLS AND JOISTS		1 1/2"
#6 AND LARGER		3/4"
#5 AND SMALLER		

TOLERANCES FOR CONCRETE COVER AND THE FABRICATION AND PLACING OF REINFORCEMENT SHALL CONFORM TO SECTION 6.0 OF ACI 117.

GENERAL NOTE:
 1. DETAILS ON THIS SHEET APPLY TO ALL DRAWINGS UNLESS OTHERWISE NOTED
 2. MAINTAIN 3" MINIMUM COVER TO ALL WATERSTOPS.