



Purchasing Division

Invitation for Bid

IFB-4558-18-DH
Grand Junction Horizon Drive Crosswalks

Responses Due:

September 12, 2018 prior to 3:30pm

Accepting Electronic Responses Only

Responses Only Submitted Through the Rocky Mountain E-Purchasing System (RMEPS)

<https://www.rockymountainbidsystem.com/default.asp>

(Purchasing Representative does not have access or control of the vendor side of RMEPS. If website or other problems arise during response submission, vendor **MUST** contact RMEPS to resolve issue prior to the response deadline. 800-835-4603)

Purchasing Representative:

Duane Hoff, Senior Buyer

duaneh@gjcity.org

(970)244-1545

This document has been developed specifically to solicit competitive responses for this solicitation, and may not be the same as previous City of Grand Junction solicitations. All vendors are urged to thoroughly review this solicitation prior to responding. Submittal by **FAX, EMAIL or HARD COPY IS NOT ACCEPTABLE** for this solicitation.

Invitation for Bids

Table of Contents

Section 1	Instruction to Bidders
Section 2	General Contract Conditions
Section 3	Statement of Work
Section 4	Contractor's Bid Form
	Price Proposal/Bid Schedule Form
	CDOT Form #606 – Anti-Collusion Affidavit
	CDOT Form #1413 – Bidders List
	Project Special Provisions
	Standard Special Provisions
Appendix A	Project Submittals
Appendix B	CDOT Disadvantage Business Enterprise (DBE) Program Plan <ul style="list-style-type: none">• CDOT Forms: 1414, 1415, 1416
Appendix C	Special Notice to Contractors
Appendix D	CDOT Form #17 – Contractor DBE Payment Certification
	CDOT Form #205 B – Sublet Permit Application
	CDOT Form #605 – Contractors Performance Capability Statement
	CDOT Form #621 – Assignment of Antitrust Claims

1. Instructions to Bidders

- 1.1. Purpose:** The City of Grand Junction is soliciting competitive bids from qualified and interested companies for all labor, equipment, and materials required for the **Grand Junction Horizon Drive Crosswalks Project**. All dimensions and scope of work should be verified by Contractors prior to submission of bids.

Note: This project shall be constructed in accordance with the current Davis Bacon Wage Rate Determination (Refer to Appendix B).

IFB Questions:

Duane Hoff, Senior Buyer
970-244-1545
duaneh@gjcity.org

- 1.2. Mandatory Pre-Bid Meeting:** **Prospective bidders are required to attend the mandatory pre-bid meeting on August 31, 2018 at 10:30am.** Meeting location will be at City Hall in the City Council Auditorium, located at 250 N. 5th Street, Grand Junction, CO. This meeting also allows the Owner to know who is planning on submitting a bid for the project. The purpose of this visit will be to inspect and to clarify the contents of this Invitation for Bids (IFB).
- 1.3. The Owner:** The Owner is the City of Grand Junction, Colorado and is referred to throughout this Solicitation. The term Owner means the Owner or his authorized representative.
- 1.4. Submission:** **Each bid shall be submitted in electronic format only, and only through the Rocky Mountain E-Purchasing website (<https://www.rockymountainbidssystem.com/default.asp>).** *This site offers both “free” and “paying” registration options that allow for full access of the Owner’s documents and for electronic submission of proposals. (Note: “free” registration may take up to 24 hours to process. Please Plan accordingly.)* Please view our “**Electronic Vendor Registration Guide**” at <http://www.gjcity.org/business-and-economic-development/bids/> for details. (Purchasing Representative does not have access or control of the vendor side of RMEPS. If website or other problems arise during response submission, vendor **MUST** contact RMEPS to resolve issue prior to the response deadline. **800-835-4603**)
- 1.5. Modification and Withdrawal of Bids Before Opening.** Bids may be modified or withdrawn by an appropriate document stating such, duly executed and submitted to the place where Bids are to be submitted at any time prior to Bid Opening.
- 1.6. Printed Form for Price Bid:** All Price Bids must be made upon the Price Bid Schedule attached, and should give the amounts both in words and in figures, and must be signed and acknowledged by the bidder.

The Offeror shall specify a unit price in figures for each pay item for which a quantity is given and shall provide the products (in numbers) of the respective unit prices and quantities in the Extended Amount column. The total Bid price shall be equal to the sum

of all extended amount prices. When an item in the Price Bid Schedule provides a choice to be made by the Offeror, Offeror's choice shall be indicated in accordance with the specifications for that particular item and thereafter no further choice shall be permitted.

Where the unit of a pay item is lump sum, the lump sum amount shall be shown in the "extended amount" column and included in the summation of the total Bid.

All blank spaces in the Price Bid Schedule must be properly filled out.

Bids by corporations must be executed in the corporate name by the president or vice president or other corporate office accompanied by evidence of authority to sign. The corporate address and state of incorporation shall be shown below the signature.

Bids by partnerships must be executed in the partnership name and signed by a partner whose title must appear under the signature and the official address of the partnership must be shown below the signature.

All names must be typed or printed below the signature.

The Offeror's Bid shall contain an acknowledgement of receipt of all Addenda, the numbers of which shall be filled in on the Contractor's Bid Form.

The contact information to which communications regarding the Bid are to be directed must be shown.

- 1.7. **Exclusions:** No oral, telephonic, emailed, or facsimile bid will be considered
- 1.8. **Contract Documents:** The complete IFB and bidder's response compose the Contract Documents. Copies of bid documents can be obtained from the City Purchasing website, <http://www.gjcity.org/business-and-economic-development/bids/> .
- 1.9. **Additional Documents:** The July 2010 edition of the "City Standard Contract Documents for Capital Improvements Construction", Plans, Specifications and other Bid Documents are available for review or download on the Public Works & Planning/Engineering page at www.gjcity.org. Electronic copies may be obtained on a CD format at the Department of Public Works and Planning at City Hall.
- 1.10. **Definitions and Terms:** See Article I, Section 3 of the General Contract Conditions in the *Standard Contract Documents for Capital Improvements Construction*.
- 1.11. **Examination of Specifications:** Bidders shall thoroughly examine and be familiar with the project Statement of Work. The failure or omission of any Offeror to receive or examine any form, addendum, or other document shall in no way relieve any Offeror from any obligation with respect to his bid. The submission of a bid shall be taken as evidence of compliance with this section. Prior to submitting a bid, each Offeror shall, at a minimum:
 - a. Examine the *Contract Documents* thoroughly;

- b. Visit the site to familiarize themselves with local conditions that may in any manner affect cost, progress, or performance of the Work;
- c. Become familiar with federal, state, and local laws, ordinances, rules, and regulations that may in any manner affect cost, progress or performance of the Work;
- d. Study and carefully correlate Bidder's observations with the *Contract Documents*, and;
- e. Notify the Engineer of all conflicts, errors, ambiguities or discrepancies in or among the *Contract Documents*

On request, the Owner will provide each Offeror access to the site to conduct such investigations and tests as each Bidder deems necessary for submission of a Bid. It shall be the Offeror's responsibility to make or obtain any additional examinations, investigations, explorations, tests and studies and obtain any additional information and data which pertain to the physical conditions (including without limitation, surface, subsurface and underground utilities) at or contiguous to the site or otherwise which may affect cost, progress or performance of the work and which the Offeror deems necessary to determine its Bid for performing the work in accordance with the time, price and other terms and conditions of the Contract Documents. Location of any excavation or boring made by Offeror shall be subject to prior approval of Owner and applicable agencies. Offeror shall fill all holes, restore all pavements to match the existing structural section and shall clean up and restore the site to its former condition upon completion of such exploration. The Owner reserves the right to require the Offeror to execute an access agreement with the Owner prior to accessing the site.

The lands upon which the Work is to be performed, rights of way, and access thereto, and other lands designated for use by Contractor in performing the Work, are identified on the Drawings.

Information and data reflected in the *Contract Documents* with respect to underground utilities at or contiguous to the site are based upon information and data furnished to the Owner and the Engineer by the owners of such underground utilities or others, and the Owner does not assume responsibility for the accuracy or completeness thereof, unless it is expressly provided otherwise in the *Contract Documents*.

By submission of a Bid, the Offeror shall be conclusively presumed to represent that the Offeror has complied with every requirement of these Instructions to Bidders, that the *Contract Documents* are not ambiguous and are sufficient in scope and detail to indicate and convey understanding of all terms and conditions for performance of the Work.

- 1.12. Questions Regarding Statement of Work:** Any information relative to interpretation of Scope of Work or specifications shall be requested of the Purchasing Representative, in writing, in ample time prior to the response time.

- 1.13. Addenda & Interpretations:** If it becomes necessary to revise any part of this solicitation, a written addendum will be posted electronically on the City's website at <http://www.gjcity.org/business-and-economic-development/bids/>. The Owner is not bound by any oral representations, clarifications, or changes made in the written specifications by Owner, unless such clarification or change is provided in written addendum form from the City Purchasing Representative.
- 1.14. Taxes:** The Owner is exempt from State retail and Federal tax. The bid price must be net, exclusive of taxes.
- 1.15. Sales and Use Taxes:** The Contractor and all Subcontractors are required to obtain exemption certificates from the Colorado Department of Revenue for sales and use taxes in accordance with the provisions of the General Contract Conditions. Bids shall reflect this method of accounting for sales and use taxes on materials, fixtures and equipment.
- 1.16. Offers Binding 60 Days:** Unless additional time is required by the Owner, or otherwise specified, all formal offers submitted shall be binding for sixty (60) calendar days following opening date, unless the Bidder, upon request of the Purchasing Representative, agrees to an extension.
- 1.17. Collusion Clause:** Each bidder by submitting a bid certifies that it is not party to any collusive action or any action that may be in violation of the Sherman Antitrust Act. Any and all bids shall be rejected if there is evidence or reason for believing that collusion exists among bidders. The Owner may, or may not, accept future bids for the same services or commodities from participants in such collusion.
- 1.18. Disqualification of Bidders:** A Bid will not be accepted from, nor shall a Contract be awarded to, any person, firm, or corporation that is in arrears to the Owner, upon debt or contract, or that has defaulted, as surety or otherwise, upon any obligation to the Owner, or that is deemed irresponsible or unreliable.

Bidders may be required to submit satisfactory evidence that they are responsible, have a practical knowledge of the project bid upon and that they have the necessary financial and other resources to complete the proposed Work.

Either of the following reasons, without limitation, shall be considered sufficient to disqualify a Bidder and Bid:

- a. More than one Bid is submitted for the same Work from an individual, firm, or corporation under the same or different name; and
 - b. Evidence of collusion among Bidders. Any participant in such collusion shall not receive recognition as a Bidder for any future work of the Owner until such participant has been reinstated as a qualified bidder.
- 1.19. Public Disclosure Record:** If the bidder has knowledge of their employee(s) or sub-contractors having an immediate family relationship with a City/County employee or elected official, the bidder must provide the Purchasing Representative with the name(s) of these individuals. These individuals are required to file an acceptable "Public

Disclosure Record”, a statement of financial interest, before conducting business with the City/County.

2. General Contract Conditions for Construction Projects

- 2.1. The Contract:** This Invitation for Bid, submitted documents, and any negotiations, when properly accepted by the City/County, shall constitute a contract equally binding between the City/County and Contractor. The contract represents the entire and integrated agreement between the parties hereto and supersedes all prior negotiations, representations, or agreements, either written or oral. The contract may be amended or modified with Change Orders, Field Orders, or Addendums.
- 2.2. The Work:** The term Work includes all labor necessary to produce the construction required by the Contract Documents, and all materials and equipment incorporated or to be incorporated in such construction.
- 2.3. Execution, Correlation, Intent, and Interpretations:** The Contract Documents shall be signed in not less than triplicate by the Owner (City/County) and Contractor. City/County will provide the contract. By executing the contract, the Contractor represents that he/she has visited the site, familiarized himself with the local conditions under which the Work is to be performed, and correlated his observations with the requirements of the Contract Documents. The Contract Documents are complementary, and what is required by any one, shall be as binding as if required by all. The intention of the documents is to include all labor, materials, equipment and other items necessary for the proper execution and completion of the scope of work as defined in the technical specifications and drawings contained herein. All drawings, specifications and copies furnished by the City/County are, and shall remain, City/County property. They are not to be used on any other project, and with the exception of one contract set for each party to the contract, are to be returned to the owner on request at the completion of the work.
- 2.4. The Owner:** The Owner is the City of Grand Junction, Colorado and is referred to throughout the Contract Documents. The term Owner means the Owner or his authorized representative. The Owner shall, at all times, have access to the work wherever it is in preparation and progress. The Contractor shall provide facilities for such access. The Owner will make periodic visits to the site to familiarize himself generally with the progress and quality of work and to determine, in general, if the work is proceeding in accordance with the contract documents. Based on such observations and the Contractor’s Application for Payment, the Owner will determine the amounts owing to the Contractor and will issue Certificates for Payment in such amounts, as provided in the contract. The Owner will have authority to reject work which does not conform to the Contract documents. Whenever, in his reasonable opinion, he considers it necessary or advisable to insure the proper implementation of the intent of the Contract Documents, he will have authority to require the Contractor to stop the work or any portion, or to require special inspection or testing of the work, whether or not such work can be then be fabricated, installed, or completed. The Owner will not be responsible for the acts or omissions of the Contractor, and sub-Contractor, or any of their agents or employees, or any other persons performing any of the work.

- 2.5. Contractor:** The Contractor is the person or organization identified as such in the Agreement and is referred to throughout the Contract Documents. The term Contractor means the Contractor or his authorized representative. The Contractor shall carefully study and compare the General Contract Conditions of the Contract, Specification and Drawings, Scope of Work, Addenda and Modifications and shall at once report to the Owner any error, inconsistency or omission he may discover. Contractor shall not be liable to the Owner for any damage resulting from such errors, inconsistencies or omissions. The Contractor shall not commence work without clarifying Drawings, Specifications, or Interpretations.
- 2.6. Sub-Contractors:** A sub-contractor is a person or organization who has a direct contract with the Contractor to perform any of the work at the site. The term sub-contractor is referred to throughout the contract documents and means a sub-contractor or his authorized representative.
- 2.7. Award of Sub-Contractors & Other Contracts for Portions of the Work:** Contractor shall submit with their bid response to the Owner, in writing for acceptance, a list of the names of the sub-contractors or other persons or organizations proposed for such portions of the work as may be designated in the proposal requirements, or, if none is so designated, the names of the sub-contractors proposed for the principal portions of the work. Prior to the award of the contract, the Owner shall notify the successful Contractor in writing if, after due investigation, has reasonable objection to any person or organization on such list. If, prior to the award of the contract, the Owner has a reasonable and substantial objection to any person or organization on such list, and refuses in writing to accept such person or organization, the successful Contractor may, prior to the award, withdraw their proposal without forfeiture of proposal security. If the successful Contractor submits an acceptable substitute with an increase in the proposed price to cover the difference in cost occasioned by the substitution, the Owner may, at their discretion, accept the increased proposal or may disqualify the Contractor. If, after the award, the Owner refuses to accept any person or organization on such list, the Contractor shall submit an acceptable substitute and the contract sum shall be increased or decreased by the difference in cost occasioned by such substitution and an appropriate Change Order shall be issued. However, no increase in the contract sum shall be allowed for any such substitution unless the Contractor has acted promptly and responsively in submitting a name with respect thereto prior to the award.
- 2.8. Quantities of Work and Unit Price:** Materials or quantities stated as unit price items in the Bid are supplied only to give an indication of the general scope of the Work, and are as such, estimates only. The Owner does not expressly or by implication agree that the actual amount of Work or material will correspond therewith, and reserves the right after award to increase or decrease the quantity of any unit item of the Work without a change in the unit price except as set forth in Article VIII, Section 70 of the *General Contract Conditions*. The City also reserves the right to make changes in the Work (including the right to delete any bid item in its entirety or add additional bid items) as set forth in Article VIII, Sections 69 through 71 of the *General Contract Conditions*.
- 2.9. Substitutions:** The materials, products and equipment described in the *Solicitation Documents* shall be regarded as establishing a standard of required performance, function, dimension, appearance, or quality to be met by any proposed substitution. No

substitution will be considered prior to receipt of Bids unless the Offeror submits a written request for approval to the City Purchasing Division at least ten (10) days prior to the date for receipt of Bids. Such requests for approval shall include the name of the material or equipment for which substitution is sought and a complete description of the proposed substitution including drawings, performance and test data, and other information necessary for evaluation, including samples if requested. The Offeror shall set forth changes in other materials, equipment, or other portions of the Work including changes of the work of other contracts, which incorporation of the proposed substitution would require to be included. The Owner's decision of approval or disapproval of a proposed substitution shall be final. If the Owner approves a proposed substitution before receipt of Bids, such approval will be set forth in an Addendum. Offerors shall not rely upon approvals made in any other manner.

- 2.10. Supervision and Construction Procedures:** The Contractor shall supervise and direct the work, using his best skill and attention. He shall be solely responsible for all construction means, methods, techniques, sequences and procedures and for coordinating all portions of the work under the contract.
- 2.11. Warranty:** The Contractor warrants to the Owner that all materials and equipment furnished under this contract will be new unless otherwise specified, and that all work will be of good quality, free from faults and defects and in conformance with the Contract Documents. All work not so conforming to these standards may be considered defective. If required by Owner, the Contractor shall furnish satisfactory evidence as to the kind and quality of materials and equipment. If within ten (10) days after written notice to the Contractor requesting such repairs or replacement, the Contractor should neglect to make or undertake with due diligence to the same, the City may make such repairs or replacements. All indirect and direct costs of such correction or removal or replacement shall be at the Contractor's expense. The Contractor will also bear the expenses of making good all work of others destroyed or damaged by the correction, removal or replacement of his defective work.
- 2.12. Permits, Fees, & Notices:** The Contractor shall secure and pay for all permits, governmental fees and licenses necessary for the proper execution and completion of the work. The Contractor shall give all notices and comply with all laws, ordinances, rules, regulations and orders of any public authority bearing on the performance of the work. If the Contractor observes that any of the Contract Documents are at variance in any respect, he shall promptly notify the Owner in writing, and any necessary changes shall be adjusted by approximate modification. If the Contractor performs any work knowing it to be contrary to such laws, ordinances, rules and regulations, and without such notice to the Owner, he shall assume full responsibility and shall bear all costs attributable.
- 2.13. Responsibility for Those Performing the Work:** The Contractor shall be responsible to the Owner for the acts and omissions of all his employees and all sub-contractors, their agents and employees, and all other persons performing any of the work under a contract with the Contractor.

- 2.14. Use of the Site:** The Contractor shall confine operations at the site to areas permitted by law, ordinances, permits and the Contract Documents, and shall not unreasonably encumber the site with any materials or equipment.
- 2.15. Cleanup:** The Contractor at all times shall keep the premises free from accumulation of waste materials or rubbish caused by his operations. At the completion of work he shall remove all his waste materials and rubbish from and about the project, as well as all his tools, construction equipment, machinery and surplus materials.
- 2.16. Insurance:** The Contractor shall secure and maintain such insurance policies as will provide the coverage and contain other provisions specified in the General Contract Conditions, or as modified in the Special Contract Conditions.

The Contractor shall file a copy of the policies or Certificates of Insurance acceptable to the City with the Engineer within ten (10) Calendar Days after issuance of the Notice of Award. These Certificates of Insurance shall contain a provision that coverage afforded under the policies shall not be canceled unless at least thirty (30) Calendar Days prior written notice has been given to the City.

- 2.17. Indemnification:** The Contractor shall defend, indemnify and save harmless the Owner, and all its officers, employees, insurers, and self-insurance pool, from and against all liability, suits, actions, or other claims of any character, name and description brought for or on account of any injuries or damages received or sustained by any person, persons, or property on account of any negligent act or fault of the Contractor, or of any Contractor's agent, employee, sub-contractor or supplier in the execution of, or performance under, any contract which may result from proposal award. Contractor shall pay any judgment with cost which may be obtained against the Owner growing out of such injury or damages.
- 2.18. Miscellaneous Conditions:** **Material Availability:** Contractors must accept responsibility for verification of material availability, production schedules, and other pertinent data prior to submission of bid. It is the responsibility of the bidder to notify the Owner immediately if materials specified are discontinued, replaced, or not available for an extended period of time. **OSHA Standards:** All bidders agree and warrant that services performed in response to this invitation shall conform to the standards declared by the US Department of Labor under the Occupational Safety and Health Act of 1970 (OSHA). In the event the services do not conform to OSHA standards, the Owner may require the services to be redone at no additional expense to the Owner.
- 2.19. Time:** Time is of the essence with respect to the time of completion of the Project and any other milestones or deadline which are part of the Contract. It will be necessary for each Bidder to satisfy the City of its ability to complete the Work within the Contract Time set forth in the Contract Documents. The Contract Time is the period of time allotted in the Contract Documents for completion of the work. The date of commencement of the work is the date established in a Notice to Proceed. If there is no Notice to Proceed, it shall be the date of the Contract or such other date as may be established therein, or as established as entered on the Bid Form. The Date of Substantial Completion of the work or designated portions thereof is the date certified by the Owner when construction is sufficiently complete, in accordance with the Contract Documents.

- 2.20. Progress & Completion:** The Contractor shall begin work on the date of commencement as defined in the Contract, and shall carry the work forward expeditiously with adequate forces and shall complete it within the contract time.
- 2.21. Payment & Completion:** The Contract Sum is stated in the Contract and is the total amount payable by the Owner to the Contractor for the performance of the work under the Contract Documents. Upon receipt of written notice that the work is ready for final inspection and acceptance and upon receipt of application for payment, the Owner's Project Manager will promptly make such inspection and, when he finds the work acceptable under the Contract Documents and the Contract fully performed, the Owner shall make payment in the manner provided in the Contract Documents.
- 2.22. Bid Bond:** Each Bid shall as a guaranty of good faith on the part of the Bidder be accompanied by a Bid Guaranty consisting of: a certified or cashier's check drawn on an approved national bank or trust company in the state of Colorado, and made payable without condition to the City; or a **Bid Bond** written by an approved corporate surety in favor of the City. The amount of the Bid Guaranty shall not be less than 5% of the total Bid amount. Once a Bid is accepted and a Contract is awarded, the apparent successful bidder has ten calendar days to enter into a contract in the form prescribed and to furnish the bonds with a legally responsible and approved surety. Failure to do so will result in forfeiture of the Bid Guaranty to the City as Liquidated Damages.

Each bidder shall guaranty its total bid price for a period of sixty (60) Calendar Days from the date of the bid opening.

- 2.23. Performance & Payment Bonds:** Contractor shall furnish a Performance and a Payment Bond, each in an amount at least equal to that specified for the contract amount as security for the faithful performance and payment of all Contractor's obligations under the Contract Documents. These bonds shall remain in effect for the duration of the Warranty Period (as specified in the Special Conditions). Contractor shall also furnish other bonds that may be required by the Special Conditions. All bonds shall be in the forms prescribed by the Contract Documents and be executed by such sureties as (1) are licensed to conduct business in the State of Colorado and (2) are named in the current list of "Companies Holding Certificates of Authority as Acceptable Sureties on Federal Bonds and as Acceptable Reinsuring Companies" as published in Circular 570 (amended) by the Audit Staff, Bureau of Accounts, U.S. Treasury Department. All bonds signed by an agent must be accompanied by a certified copy of the Authority Act. If the surety on any bond furnished by the Contractor is declared bankrupt, or becomes insolvent, or its rights to do business in Colorado are terminated, or it ceases to meet the requirements of clauses (1) and (2) of this section, Contractor shall within five (5) days thereafter substitute another bond and surety, both of which shall be acceptable to the City.
- 2.24. Retention:** The Owner will deduct money from the partial payments in amounts considered necessary to protect the interest of the Owner and will retain this money until after completion of the entire contract. The amount to be retained from partial payments will be five (5) percent of the value of the completed work, and not greater than five (5) percent of the amount of the Contract. When the retainage has reached five (5) percent of the

amount of the Contract no further retainage will be made and this amount will be retained until such time as final payment is made.

- 2.25. Liquidated Damages for Failure to Enter Into Contract:** Should the Successful Bidder fail or refuse to enter into the Contract within ten Calendar Days from the issuance of the Notice of Award, the City shall be entitled to collect the amount of such Bidder's Bid Guaranty as Liquidated Damages, not as a penalty but in consideration of the mutual release by the City and the Successful Bidder of all claims arising from the City's issuance of the Notice of Award and the Successful Bidder's failure to enter into the Contract and the costs to award the Contract to any other Bidder, to readvertise, or otherwise dispose of the Work as the City may determine best serves its interest.
- 2.26. Liquidated Damages for Failure to Meet Project Completion Schedule:** If the Contractor does not achieve Final Completion by the required date, whether by neglect, refusal or any other reason, the parties agree and stipulate that the Contractor shall pay liquidated damages to the City for each such day that final completion is late. As provided elsewhere, this provision does not apply for delays caused by the City. The date for Final Completion may be extended in writing by the Owner.

The Contractor agrees that as a part of the consideration for the City's awarding of this Contract liquidated damages in the daily amount of **\$350.00** is reasonable and necessary to pay for the actual damages resulting from such delay. The parties agree that the real costs and injury to the City for such delay include hard to quantify items such as: additional engineering, inspection and oversight by the City and its agents; additional contract administration; inability to apply the efforts of those employees to the other work of the City; perceived inefficiency of the City; citizens having to deal with the construction and the Work, rather than having the benefit of a completed Work, on time; inconvenience to the public; loss of reputation and community standing for the City during times when such things are very important and very difficult to maintain.

The Contractor must complete the Work and achieve final completion included under the Bid Schedule in the number of consecutive calendar days after the City gives is written Notice to Proceed. When the Contractor considers the entire Work ready for its intended use, Contractor shall certify in writing that the Work is substantially complete. In addition to the Work being substantially complete, Final Completion date is the date by which the Contractor shall have fully completed all clean-up, and all items that were identified by the City in the inspection for final completion. Unless otherwise stated in the Special Conditions, for purposes of this liquidated damages clause, the Work shall not be finished and the Contract time shall continue to accrue until the City gives its written Final Acceptance.

If the Contractor shall fail to pay said liquidated damages promptly upon demand thereof after having failed to achieve Final Completion on time, the City shall first look to any retainage or other funds from which to pay said liquidated damages; if retainage or other liquid funds are not available to pay said liquidated damages amounts, the Surety on the Contractor's Performance Bond and Payment Bond shall pay such liquidated damages. In addition, the City may withhold all, or any part of, such liquidated damages from any payment otherwise due the Contractor.

Liquidated damages as provided do not include any sums to reimburse the City for extra costs which the City may become obligated to pay on other contracts which were delayed or extended because of the Contractor's failure to complete the Work within the Contract Time. Should the City incur additional costs because of delays or extensions to other contracts resulting from the Contractor's failure of timely performance, the Contractor agrees to pay these costs that the City incurs because of the Contractor's delay, and these payments are separate from and in addition to any liquidated damages.

The Contractor agrees that the City may use its own forces or hire other parties to obtain Substantial or Final Completion of the work if the time of completion has elapsed and the Contractor is not diligently pursuing completion. In addition to the Liquidated Damages provided for, the Contractor agrees to reimburse the City for all expenses thus incurred.

- 2.27. Contingency/Force Account:** Contingency/Force Account work will be authorized by the Owner's Project Manager and is defined as minor expenses to cover miscellaneous or unforeseen expenses related to the project. The expenses are not included in the Drawings, Specifications, or Scope of Work and are necessary to accomplish the scope of this contract. Contingency/Force Account Authorization will be directed by the Owner through an approved form. Contingency/Force Account funds are the property of the Owner and any Contingency/Force Account funds, not required for project completion, shall remain the property of the Owner. Contractor is not entitled to any Contingency/Force Account funds, that are not authorized by Owner or Owner's Project Manager.
- 2.28. Protection of Persons & Property:** The Contractor shall comply with all applicable laws, ordinances, rules, regulations and orders of any public authority having jurisdiction for the safety of persons or property or to protect them from damage, injury or loss. Contractor shall erect and maintain, as required by existing safeguards for safety and protection, and all reasonable precautions, including posting danger signs or other warnings against hazards promulgating safety regulations and notifying owners and users of adjacent utilities. When or where any direct or indirect damage or injury is done to public or private property by or on account of any act, omission, neglect, or misconduct by the Contractor in the execution of the work, or in consequence of the non-execution thereof by the Contractor, he shall restore, at his own expense, such property to a condition similar or equal to that existing before such damage or injury was done, by repairing, rebuilding, or otherwise restoring as may be directed, or it shall make good such damage or injury in an acceptable manner.
- 2.29. Changes in the Work:** The Owner, without invalidating the contract, may order changes in the work within the general scope of the contract consisting of additions, deletions or other revisions, the contract sum and the contract time being adjusted accordingly. All such changes in the work shall be authorized by Change Order and shall be executed under the applicable conditions of the contract documents. A Change Order is a written order to the Contractor signed by the Owner issued after the execution of the contract, authorizing a change in the work or an adjustment in the contract sum or the contract time. The contract sum and the contract time may be changed only by Change Order.
- 2.30. Claims for Additional Cost or Time:** If the Contractor wishes to make a claim for an increase in the contract sum or an extension in the contract time, he shall give the Owner

written notice thereof within a reasonable time after the occurrence of the event giving rise to such claim. This notice shall be given by the Contractor before proceeding to execute the work, except in an emergency endangering life or property in which case the Contractor shall precede in accordance with the regulations on safety. No such claim shall be valid unless so made. Any change in the contract sum or contract time resulting from such claim shall be authorized by Change Order.

- 2.31. Minor Changes in the Work:** The Owner shall have authority to order minor changes in the work not involving an adjustment in the contract sum or an extension of the contract time and not inconsistent with the intent of the contract documents.
- 2.32. Field Orders:** The Owner may issue written Field Orders which interpret the Contract Documents in accordance with the specifications, or which order minor changes in the work in accordance with the agreement, without change in the contract sum or time. The Contractor shall carry out such Field Orders promptly.
- 2.33. Uncovering & Correction of Work:** The Contractor shall promptly correct all work rejected by the Owner as defective or as failing to conform to the contract documents whether observed before or after substantial completion and whether or not fabricated installed or completed. The Contractor shall bear all costs of correcting such rejected work, including the cost of the Owner's additional services thereby made necessary. If within one (1) year after the date of completion or within such longer period of time as may be prescribed by law or by the terms of any applicable special guarantee required by the contract documents, any of the work found to be defective or not in accordance with the contract documents, the Contractor shall correct it promptly after receipt of a written notice from the Owner to do so unless the Owner has previously given the Contractor a written acceptance of such condition. The Owner shall give such notice promptly after discover of condition. All such defective or non-conforming work under the above paragraphs shall be removed from the site where necessary and the work shall be corrected to comply with the contract documents without cost to the Owner. The Contractor shall bear the cost of making good all work of separate Contractors destroyed or damaged by such removal or correction. If the Owner prefers to accept defective or non-conforming work, he may do so instead of requiring its removal and correction, in which case a Change Order will be issued to reflect an appropriate reduction in the payment or contract sum, or, if the amount is determined after final payment, it shall be paid by the Contractor.
- 2.30. Amendment:** No oral statement of any person shall modify or otherwise change, or affect the terms, conditions or specifications stated in the resulting contract. All amendments to the contract shall be made in writing by the Owner.
- 2.31. Assignment:** The Contractor shall not sell, assign, transfer or convey any contract resulting from this IFB, in whole or in part, without the prior written approval from the Owner.
- 2.32. Compliance with Laws:** Bids must comply with all Federal, State, County and local laws governing or covering this type of service and the fulfillment of all ADA (Americans with Disabilities Act) requirements.

- 2.33. Confidentiality:** All information disclosed by the Owner to the Contractor for the purpose of the work to be done or information that comes to the attention of the Contractor during the course of performing such work is to be kept strictly confidential.
- 2.34. Conflict of Interest:** No public official and/or City/County employee shall have interest in any contract resulting from this IFB.
- 2.35. Contract Termination:** This contract shall remain in effect until any of the following occurs: (1) contract expires; (2) completion of services; (3) acceptance of services or, (4) for convenience terminated by either party with a written *Notice of Cancellation* stating therein the reasons for such cancellation and the effective date of cancellation.
- 2.36. Employment Discrimination:** During the performance of any services per agreement with the Owner, the Contractor, by submitting a Bid, agrees to the following conditions:
- 2.36.1.** The Contractor shall not discriminate against any employee or applicant for employment because of race, religion, color, sex, age, handicap, or national origin except when such condition is a legitimate occupational qualification reasonably necessary for the normal operations of the Contractor. The Contractor agrees to post in conspicuous places, visible to employees and applicants for employment, notices setting forth the provisions of this nondiscrimination clause.
- 2.36.2.** The Contractor, in all solicitations or advertisements for employees placed by or on behalf of the Contractor, shall state that such Contractor is an Equal Opportunity Employer.
- 2.36.3.** Notices, advertisements, and solicitations placed in accordance with federal law, rule, or regulation shall be deemed sufficient for the purpose of meeting the requirements of this section.
- 2.37. Affirmative Action:** In executing a Contract with the City, the Contractor agrees to comply with Affirmative Action and Equal Employment Opportunity regulations presented in the General Contract Conditions.
- 2.38. Immigration Reform and Control Act of 1986 and Immigration Compliance:** The Offeror certifies that it does not and will not during the performance of the contract employ illegal alien workers or otherwise violate the provisions of the Federal Immigration Reform and Control Act of 1986 and/or the immigration compliance requirements of State of Colorado C.R.S. § 8-17.5-101, *et.seq.* (House Bill 06-1343).
- 2.39. Ethics:** The Contractor shall not accept or offer gifts or anything of value nor enter into any business arrangement with any employee, official, or agent of the Owner.
- 2.40. Failure to Deliver:** In the event of failure of the Contractor to deliver services in accordance with the contract terms and conditions, the Owner, after due oral or written notice, may procure the services from other sources and hold the Contractor responsible for any costs resulting in additional purchase and administrative services. This remedy shall be in addition to any other remedies that the Owner may have.

- 2.41. Failure to Enforce:** Failure by the Owner at any time to enforce the provisions of the contract shall not be construed as a waiver of any such provisions. Such failure to enforce shall not affect the validity of the contract or any part thereof or the right of the Owner to enforce any provision at any time in accordance with its terms.
- 2.42. Force Majeure:** The Contractor shall not be held responsible for failure to perform the duties and responsibilities imposed by the contract due to legal strikes, fires, riots, rebellions, and acts of God beyond the control of the Contractor, unless otherwise specified in the contract.
- 2.43. Independent Contractor:** The Contractor shall be legally considered an Independent Contractor and neither the Contractor nor its employees shall, under any circumstances, be considered servants or agents of the Owner. The Owner shall be at no time legally responsible for any negligence or other wrongdoing by the Contractor, its servants, or agents. The Owner shall not withhold from the contract payments to the Contractor any federal or state unemployment taxes, federal or state income taxes, Social Security Tax or any other amounts for benefits to the Contractor. Further, the Owner shall not provide to the Contractor any insurance coverage or other benefits, including Workers' Compensation, normally provided by the Owner for its employees.
- 2.44. Nonconforming Terms and Conditions:** A bid that includes terms and conditions that do not conform to the terms and conditions of this Invitation for Bid is subject to rejection as non-responsive. The Owner reserves the right to permit the Contractor to withdraw nonconforming terms and conditions from its bid prior to a determination by the Owner of non-responsiveness based on the submission of nonconforming terms and conditions.

Items for non-responsiveness may include, but not be limited to:

- a. Submission of the Bid on forms other than those supplied by the City;
- b. Alteration, interlineation, erasure, or partial detachment of any part of the forms which are supplied herein;
- c. Inclusion of unauthorized additions conditional or alternate Bids or irregularities of any kind which may tend to make the Bid incomplete, indefinite, or ambiguous as to its meaning;
- d. Failure to acknowledge receipt of any or all issued Addenda;
- e. Failure to provide a unit price or a lump sum price, as appropriate, for each pay item listed except in the case of authorized alternative pay items;
- f. Failure to list the names of Subcontractors used in the Bid preparation as may be required in the Solicitation Documents;
- g. Submission of a Bid that, in the opinion of the Owner, is unbalanced so that each item does not reasonably carry its own proportion of cost or which contains inadequate or unreasonable prices for any item;

- h. Tying of the Bid with any other bid or contract; and
- i. Failure to calculate Bid prices as described herein.

2.45. Evaluation of Bids and Offers: The Owner reserves the right to:

- reject any and all Bids,
- waive any and all informalities,
- negotiate final terms with the Successful Bidder, and
- disregard any and all nonconforming, nonresponsive or conditional Bids.

Discrepancies between words and figures will be resolved in favor of words. Discrepancies between Unit Prices and Extended Prices will be resolved in favor of the Unit Prices. Discrepancies between the indicated sum of any column of figures and the correct sum thereof will be resolved in favor of the correct sum. The corrected extensions and totals will be shown in the tabulation of Bids.

The Owner may consider the qualifications and experience of Subcontractors and other persons and organizations (including those who are to furnish the principal items of material or equipment) proposed for those portions of the work as to which the identity of Subcontractors and other persons and organizations must be submitted. Operating costs, maintenance considerations performance data, and guarantees of materials and equipment may also be considered by the Owner.

The Owner will conduct such investigations as deemed necessary to assist in the evaluation of any Bid and to establish the responsibility, qualifications and financial ability of the Offeror, proposed Subcontractors and other persons and organizations to do the Work in accordance with the *Contract Documents* to the City's satisfaction within the Contract Time.

The Offeror shall furnish the Owner all information and data requested by the Owner to determine the ability of the Offeror to perform the Work. The Owner reserves the right to reject the Bid if the evidence submitted by, or investigation of such Offeror fails to satisfy the Owner that such Offeror is properly qualified to carry out the obligations of the Contract and to complete the Work contemplated therein.

By submitting a Bid, each Offeror authorizes the Owner to perform such investigation of the Offeror as the Owner deems necessary to establish the responsibility, qualifications and financial ability of the Offeror and, by its signature thereon, authorizes the Owner to obtain reference information concerning the Offeror and releases the party providing such information and the Owner from any and all liability to the Offeror as a result of such reference information so provided.

The Owner reserves the right to reject the Bid of any Offeror who does not pass any evaluation to the Owner's satisfaction.

If the Contract is to be awarded, it will be awarded to the Offeror who, by evaluation, the Owner determines will best meet the Owner's interests.

The Owner reserves the right to accept or reject the Work contained in any of the Price Bid Schedules or alternates, either in whole or in part.

2.46. Award of Contract: Unless otherwise indicated, a single award will be made for all the bid items in an individual bid schedule. In the event that the Work is contained in more than one Bid Schedule, the City may award Schedules individually or in combination. In the case of two Bid Schedules which are alternative to each other, only one of such alternative Schedules will be awarded. Within forty-five (45) Calendar Days of Bid Opening, the City will issue a Notice of Award to the Successful Bidder which will be accompanied by four (4) unsigned copies of the Contract and the Performance and Payment Bond forms. Within ten (10) Calendar Days thereafter, the Successful Bidder shall sign and deliver four (4) copies of the Contract, Performance Bond, Payment Bond and Certificates of Insurance to the City. Within ten (10) Calendar Days thereafter, the City will deliver two (2) fully executed counterparts of the Contract to the Contractor. No contract shall exist between the Successful Bidder and the City and the Successful Bidder shall have no rights at law or in equity until the Contract has been duly executed by the City.

The Successful Bidder's failure to sign and submit a Contract and other documents set forth in this Paragraph within the prescribed time shall be just cause of annulment of the award, and forfeiture of the Bid Guaranty. The award of Contract may then be made to the next qualified Bidder in the same manner as previously prescribed.

2.47. Ownership: All plans, prints, designs, concepts, etc., shall become the property of the Owner.

2.48. Oral Statements: No oral statement of any person shall modify or otherwise affect the terms, conditions, or specifications stated in this document and/or resulting agreement. All modifications to this request and any agreement must be made in writing by the Owner.

2.49. Patents/Copyrights: The Contractor agrees to protect the Owner from any claims involving infringements of patents and/or copyrights. In no event shall the Owner be liable to the Contractor for any/all suits arising on the grounds of patent(s)/copyright(s) infringement. Patent/copyright infringement shall null and void any agreement resulting from response to this IFB.

2.50. Remedies: The Contractor and Owner agree that both parties have all rights, duties, and remedies available as stated in the Uniform Commercial Code.

2.51. Venue: Any agreement as a result of responding to this IFB shall be deemed to have been made in, and shall be construed and interpreted in accordance with, the laws of the City of Grand Junction, Mesa County, Colorado.

2.52. Expenses: Expenses incurred in preparation, submission and presentation of this IFB are the responsibility of the company and cannot be charged to the Owner.

- 2.53. Sovereign Immunity:** The Owner specifically reserves its right to sovereign immunity pursuant to Colorado State Law as a defense to any action arising in conjunction to this agreement.
- 2.54. Non-Appropriation of Funds:** The contractual obligation of the Owner under this contract is contingent upon the availability of appropriated funds from this fiscal year budget as approved by the City Council or Board of County Commissioners from this fiscal year only. State of Colorado Statutes prohibit obligation of public funds beyond the fiscal year for which the budget was approved. Anticipated expenditures/obligations beyond the end of the current Owner's fiscal year budget shall be subject to budget approval. Any contract will be subject to and must contain a governmental non-appropriation of funds clause.
- 2.55. Cooperative Purchasing:** Purchases as a result of this solicitation are primarily for the City/County. Other governmental entities may be extended the opportunity to utilize the resultant contract award with the agreement of the successful provider and the participating agencies. All participating entities will be required to abide by the specifications, terms, conditions and pricings established in this Bid. The quantities furnished in this bid document are for only the City/County. It does not include quantities for any other jurisdiction. The City or County will be responsible only for the award for its jurisdiction. Other participating entities will place their own awards on their respective Purchase Orders through their purchasing office or use their purchasing card for purchase/payment as authorized or agreed upon between the provider and the individual entity. The City/County accepts no liability for payment of orders placed by other participating jurisdictions that choose to piggy-back on our solicitation. Orders placed by participating jurisdictions under the terms of this solicitation will indicate their specific delivery and invoicing instructions.
- 2.56. Keep Jobs in Colorado Act:** Contractor shall be responsible for ensuring compliance with Article 17 of Title 8, Colorado Revised Statutes requiring 80% Colorado labor to be employed on public works. Contractor shall, upon reasonable notice provided by the Owner, permit the Owner to inspect documentation of identification and residency required by C.R.S. §8-17-101(2)(a). If Contractor claims it is entitled to a waiver pursuant to C.R.S. §8-17-101(1), Contractor shall state that there is insufficient Colorado labor to perform the work such that compliance with Article 17 would create an undue burden that would substantially prevent a project from proceeding to completion, and shall include evidence demonstrating the insufficiency and undue burden in its response.

Unless expressly granted a waiver by the Owner pursuant to C.R.S. §8-17-101(1), Contractor shall be responsible for ensuring compliance with Article 17 of Title 8, Colorado Revised Statutes requiring 80% Colorado labor to be employed on public works. Contractor shall, upon reasonable notice provided by the Owner, permit the Owner to inspect documentation of identification and residency required by C.R.S. §8-17-101(2)(a).

2.56.1. "Public project" is defined as:

- (a) any construction, alteration, repair, demolition, or improvement of any land, building, structure, facility, road, highway, bridge, or other public

improvement suitable for and intended for use in the promotion of the public health, welfare, or safety and any maintenance programs for the upkeep of such projects

- (b) for which appropriate or expenditure of moneys may be reasonably expected to be \$500,000.00 or more in the aggregate for any fiscal year
- (c) except any project that receives federal moneys.

3. Statement of Work

3.1. GENERAL: The City of Grand Junction is soliciting competitive bids from qualified and interested companies for all labor, equipment, and materials required for the **Grand Junction Horizon Drive Crosswalk Project**. All dimensions and scope of work should be verified by Contractors prior to submission of bids.

3.2. PROJECT DESCRIPTION: The Project generally consists of the installation of approximately 420 SY of Concrete Pavement, 141 Tons Aggregate Base Course, 3 street and 6 pedestrian lights, 3 rectangular rapid flashing beacon systems, striping and signage.

3.3. SPECIAL CONDITIONS & PROVISIONS:

3.3.1 Mandatory Pre-Bid Meetings: Prospective bidders are required to attend the mandatory pre-bid meeting on August 31, 2018 at 10:30am. Meeting location will be in the City Council Auditorium, located at City Hall, 250 N. 5th Street, Grand Junction, CO. This meeting also allows the Owner to know who is planning on submitting a bid for the project. The purpose of this visit will be to inspect and to clarify the contents of this Invitation for Bids (IFB).

3.3.2 QUESTIONS REGARDING SOLICIATION PROCESS/SCOPE OF WORK:

Duane Hoff Jr., Senior Buyer
City of Grand Junction
duaneh@gjcity.org

3.3.2 Project Manager: The Project Manager for the Project is Jerod Timothy, Project Manager, who can be reached at (970)244-1565. During Construction, all notices, letters, submittals, and other communications directed to the City shall be addressed and mailed or delivered to:

City of Grand Junction
Department of Public Works and Planning
Attn: Jerod Timothy, Project Manager
250 North Fifth Street
Grand Junction, CO 81501

3.3.3 Affirmative Action: The Contractor is not required to submit a written Affirmative Action Program for the Project.

3.3.4 Pricing: Pricing shall be all inclusive to include but not be limited to: all labor,

equipment, supplies, materials, freight (F.O.B. Destination – Freight Pre-paid and Allowed to each site), travel, mobilization costs, fuel, set-up and take down costs, and full-time inspection costs, and all other costs related to the successful completion of the project.

The Owner shall not pay nor be liable for any other additional costs including but not limited to: taxes, shipping charges, insurance, interest, penalties, termination payments, attorney fees, liquidated damages, etc.

3.3.5 Freight/Shipping: All freight/shipping shall be F.O.B. Destination – Freight Pre-Paid and Allowed to the project site(s), Grand Junction, CO.

Contractor must meet all federal, state, and local rules, regulations, and requirements for providing such services.

3.3.6 Contract: A binding contract shall consist of: (1) the IFB and any amendments thereto, (2) the bidder's response (bid) to the IFB, (3) clarification of the bid, if any, and (4) the City's Purchasing Department's acceptance of the bid by "Notice of Award" or by "Purchase Order". All Exhibits and Attachments included in the IFB shall be incorporated into the contract by reference.

A. The contract expresses the complete agreement of the parties and, performance shall be governed solely by the specifications and requirements contained therein.

B. Any change to the contract, whether by modification and/or supplementation, must be accomplished by a formal contract amendment signed and approved by and between the duly authorized representative of the bidder and the City Purchasing Division or by a modified Purchase Order prior to the effective date of such modification. The bidder expressly and explicitly understands and agrees that no other method and/or no other document, including acts and oral communications by or from any person, shall be used or construed as an amendment or modification to the contract.

3.3.7 Time of Completion: The scheduled time of Completion for the Project is **82 Calendar Days** from the starting date specified in the Notice to Proceed.

Completion is achieved when site cleanup and all punch list items (resulting from the final inspection) have been completed. Completion shall have the meaning set forth in Article I, Section 3 (Definitions and Terms) of the General Contract Conditions.

3.3.8 Working Days and Hours: No work shall be done on Saturdays, Sundays or City Holidays without the written consent of the City. No work, other than preparation and clean-up, shall be done outside the hours between 8:00 a.m. and 4:30 p.m. without the written consent of the City. Requests for such work shall be made a minimum of forty-eight (48) hours prior to the day or days for which the request is being made. Emergency work may be done without prior consent provided the Contractor notifies the Project Engineer or Project Inspector prior to beginning the work.

3.3.9 Licenses and Permits: Contractor is responsible for obtaining all necessary licenses and permits required for Construction, at Contractors expense. See Section 2.12. Contractor shall supply to Owner all copies of finalized permits.

3.3.10 Permits: The following permits are required for the Project and will be obtained by the City at no cost to the Contractor:
None

The following permits are required for the Project and shall be obtained and paid for by the Contractor, with the costs included in the total bid price for the Project:
None

3.3.11 City Furnished Materials: The City will furnish the following materials for the Project:

- AutoCAD drawings for survey stake-out.

3.3.12 Project Newsletters: A newsletter for the Project will be prepared and distributed by the City. It will include general information about the Project including interruptions in utility services, street closures, parking restrictions, project schedule, and the names and telephone numbers of the contacts for the City and Contractor. The newsletter will be mailed approximately one week before the Contractor commences work.

3.3.13 Project Sign: Project signs, if any, will be furnished and installed by the City.

3.3.14 Authorized Representatives of the City: Those authorized to represent the City shall include Purchasing Agent, Engineers, and Inspectors employed by the City, only.

3.3.15 Stockpiling Materials and Equipment: When approved by the Project Engineer, the Contractor may stockpile and store materials and equipment within public right-of-way. The Contractor shall be responsible for obtaining written permission to use private property for storage of materials and equipment. Copies of the above-mentioned agreements shall be submitted to the Project Engineer prior to use of the property.

3.3.16 Clean-Up: The Contractor shall clear the construction site of all trash and on-site waste daily, including scrap from construction materials. The costs for all clean-up work shall be considered incidental and will not be paid for separately.

3.3.17 Quality Control Testing: Supplier shall perform quality control testing on concrete. The City will perform all other necessary QA/QC.

3.3.18 Uranium Mill Tailings: It is anticipated that radioactive mill tailings will be encountered on this Project.

3.3.19 Fugitive Petroleum or Other Contamination: It is anticipated that soil contamination from fugitive petroleum or other contaminants will not be encountered with the Project.

3.3.20 Excess Material: All excess materials shall be disposed in accordance with General Contract Condition Section 50.

3.3.21 Construction Equipment Storage: The Contractor will not be allowed to store construction equipment and/or construction materials within the City roadway right-of-way.

3.3.22 Asphalt and Concrete Removal: During removal operations the Contractor shall saw cut at the interface at full depth of concrete or asphalt (6" minimum) as to not damage new asphalt overlay. Any damage to the existing asphalt shall be patched back by the contractor at no cost to the City. All patch work shall be at a minimum of 2' wide and 10' in length (4" Thick).

3.3.23 Schedule of Submittals: The Contractor at a minimum shall deliver these submittals at the pre-construction:

- Construction schedule submitted at or prior to the pre-construction meeting and updated as necessary to reflect actual conditions
- Hourly rate table for labor and equipment to be used on this project.
- Provide Traffic Control Plan for all phases of work
- Concrete Mix Designs
- Aggregate Base Course (Class 6)
- Conduit
- RFFB, Ped and Street Light Appurtenances

3.3.24 Existing Utilities and Structures: The location of existing utilities and structures shown on the Plans are approximate. It is the responsibility of the Contractor to locate and protect all structures and utilities in accordance with General Contract Condition Section 37. The Contractor shall coordinate with the utility companies any necessary relocation of utilities and schedule his work accordingly. See Project Special Provisions.

3.3.25 Incidental Items: Any item of work not specifically identified or paid for directly, but which is necessary for the satisfactory completion of any paid items of work, will be considered as incidental to those items, and will be included in the cost of those items.

3.3.26 Street and Pedestrian Lights and RRFB's: Contractor shall immediately order the street and pedestrian lights and RRFB's once a fully executed Contract is signed between the City and the Contractor. The Sternberg Pedestrian Lights are estimated to take 12-14 weeks for delivery from when the order is placed and the RRFB's 4 - 6 weeks.

3.3.27 Schedule: The Contractor shall reach substantial completion on or before Friday, November 2, 2018. Substantial completion shall include all concrete flatwork, signage and striping.

3.4. SCOPE OF WORK: See Specifications and Construction Plans.

3.5. Attachments:

Appendix A: Project Submittal Form

Appendix B: Construction Drawings

3.6. Contractor Bid Documents: For Contractor's convenience, the following is a list of forms/items to be submitted with the Contractor's bid response. However, should a form/item not be listed in this section, but required in the solicitation documents, it is the Contractor's responsibility to ensure all forms/items are submitted.

- **Contractor's Bid Form**

- **Price Bid Schedule**

3.7. IFB TENTATIVE TIME SCHEDULE:

Invitation for Bids available	August 24, 2018
Mandatory Pre-Bid Meeting	August 31, 2018
Inquiry deadline, no questions after this date	September 4, 2018
Addendum Posted	September 6, 2018
Submittal deadline for proposals (Bid Opening)	September 12, 2018
City Council Approval	October 3, 2018
Notice of Award & Contract execution	TBD
Bonding & Insurance Cert due	TBD
Preconstruction meeting	October 10, 2018
Work begins	October 15, 2018
Final Completion	82 Calendar Days from Notice to Proceed

4. Contractor's Bid Form

Bid Date: _____

Project: IFB-4558-18-DH "Grand Junction Horizon Crosswalks"

Bidding Company: _____

Name of Authorized Agent: _____

Email _____

Telephone _____ **Address** _____

City _____ **State** _____ **Zip** _____

The undersigned Bidder, in compliance with the Invitation for Bids, having examined the Instruction to Bidders, General Contract Conditions, Statement of Work, Specifications, and any and all Addenda thereto, having investigated the location of, and conditions affecting the proposed work, hereby proposes to furnish all labor, materials and supplies, and to perform all work for the Project in accordance with Contract Documents, within the time set forth and at the prices stated below. These prices are to cover all expenses incurred in performing the work required under the Contract Documents, of which this Contractor's Bid Form is a part.

The undersigned Contractor does hereby declare and stipulate that this offer is made in good faith without collusion or connection to any person(s) providing an offer for the same work, and that it is made in pursuance of, and subject to, all terms and conditions of the Instructions to Bidders, the Specifications, and all other Solicitation Documents, all of which have been examined by the undersigned.

The Contractor also agrees that if awarded the Contract, to provide insurance certificates within ten (10) working days of the date of Notification of Award. Submittal of this offer will be taken by the Owner as a binding covenant that the Contractor will be prepared to complete the project in its entirety.

The Owner reserves the right to make the award on the basis of the offer deemed most favorable, to waive any formalities or technicalities and to reject any or all offers. It is further agreed that this offer may not be withdrawn for a period of sixty (60) calendar days after closing time. Submission of clarifications and revised offers automatically establish a new thirty day (30) period.

Prices in the bid proposal have not knowingly been disclosed with another provider and will not be prior to award.

- Prices in this bid proposal have been arrived at independently, without consultation, communication or agreement for the purpose of restricting competition.
- No attempt has been made nor will be to induce any other person or firm to submit a bid proposal for the purpose of restricting competition.
- The individual signing this bid proposal certifies they are a legal agent of the offeror, authorized to represent the offeror and is legally responsible for the offer with regard to supporting documentation and prices provided.
- Direct purchases by the City of Grand Junction are tax exempt from Colorado Sales or Use Tax. Tax exempt No. 98-903544. The undersigned certifies that no Federal, State, County or Municipal tax will be added to the above quoted prices.
- City of Grand Junction payment terms shall be Net 30 days.
- Prompt payment discount of _____ percent of the net dollar will be offered to the Owner if the invoice is paid within _____ days after the receipt of the invoice.

RECEIPT OF ADDENDA: the undersigned Contractor acknowledges receipt of Addenda to the Solicitation, Specifications, and other Contract Documents.

State number of Addenda received: _____.

It is the responsibility of the Bidder to ensure all Addenda have been received and acknowledged.
By signing below, the Undersigned agree to comply with all terms and conditions contained herein.

Company: _____

Authorized Signature: _____

Title: _____

Bid Schedule: Grand Junction Horizon Drive Crosswalks

Contractor: _____

Item No.	CDOT, City Ref.	Description	Quantity	Units	Unit Price	Total Price
1	201-00000	Clearing and Grubbing	1.	LS	\$ _____	\$ _____
2	202-00220	Removal of Asphalt Mat	253.	SY	\$ _____	\$ _____
3	202-00200	Removal of Sidewalk	81.	SY	\$ _____	\$ _____
4	202-00203	Removal of Curb and Gutter	64.	LF	\$ _____	\$ _____
5	202-00026	Removal of Slope and Ditch Paving	36.	SY	\$ _____	\$ _____
6	202-00195	Removal of Median Cover	56.	SY	\$ _____	\$ _____
7	202-05004	Sawing Concrete (4 Inch)	24.	LF	\$ _____	\$ _____
8	202-05008	Sawing Concrete (8 Inch)	56.	LF	\$ _____	\$ _____
9	203-01597	Potholing	24.	HR	\$ _____	\$ _____
10	207-00205	Topsoil	2.	CY	\$ _____	\$ _____
11	208-00045	Concrete Washout Structure	1.	EA	\$ _____	\$ _____
12	208-00054	Storm Drain Inlet Protection (Type II)	6.	EA	\$ _____	\$ _____
13	208-00103	Removal and Disposal of Sediment (Labor)	10.	HOUR	\$ _____	\$ _____
14	208-00207	Erosion Control Management	15.	DAY	\$ _____	\$ _____
15	212-00050	Sod	71.	SF	\$ _____	\$ _____
16	213-00065	Inorganic Mulch (3/4" Washed Rock)	1.	CY	\$ _____	\$ _____
17	213-00065	Inorganic Mulch (River Cobble)	1.	CY	\$ _____	\$ _____
18	213-00065	Inorganic Mulch (1 1/2" Tan Granite)	1.	CY	\$ _____	\$ _____
19	304-06000	Aggregate Base Course (Class 6)	141.	TON	\$ _____	\$ _____
20	412-00600	Concrete Pavement (6 Inch)	50.	SY	\$ _____	\$ _____
21	601-03050	Concrete Class D (Wall)	12.	CY	\$ _____	\$ _____
22	602-00000	Reinforcing Steel	600.	LB	\$ _____	\$ _____
23	608-00000	Concrete Sidewalk	71.	SY	\$ _____	\$ _____
24	608-00010	Concrete Curb Ramp Type 3B	133.	SY	\$ _____	\$ _____
25	608-00010	Concrete Curb Ramp Type 1B	4.	SY	\$ _____	\$ _____
26	608-00015	Detectable Warnings	144.	SF	\$ _____	\$ _____
27	609-20010	Curb Type 2 (Section B)	18.	LF	\$ _____	\$ _____
28	609-21010	Curb and Gutter Type 2 (Section I-B)	274.	LF	\$ _____	\$ _____
29	610-00024	Median Cover Material (Concrete) (Davis Color No. 5084 (3 LB) Spanish	650.	SF	\$ _____	\$ _____
30	610-00100	Median Edging (Concrete) (Davis Color No. 5084 (3 LB) Spanish Gold)	226.	LF	\$ _____	\$ _____
31	613-01200	2 Inch Electrical Conduit (Plastic)	261.	LF	\$ _____	\$ _____
32	613-07001	Type One Pull Box	22.	EA	\$ _____	\$ _____
33	613-10000	Wiring	1.	LS	\$ _____	\$ _____
34	613-30005	Light Standard and Luminaire (Pedestrian)	6.	EA	\$ _____	\$ _____
35	613-34303	Light Standard Metal (30 Foot) (Special) (2 Arm)	3.	EA	\$ _____	\$ _____
36	613-40010	Light Standard Foundation	9.	EA	\$ _____	\$ _____
37	613-50106	Lighting Control Center	1.	EA	\$ _____	\$ _____
38	614-80003	Rectangular Rapid Flashing Beacon System	3.	EA	\$ _____	\$ _____
39	614-00011	Sign Panel (Class I)	234.	SF	\$ _____	\$ _____
40	614-00200	Steel Sign Post (U-2)	6.	EA	\$ _____	\$ _____
41	620-00020	Sanitary Facility	Lump	SUM	---	\$ _____
42	625-00000	Construction Surveying	Lump	SUM	---	\$ _____
43	626-00000	Mobilization	Lump	SUM	---	\$ _____
44	626-01103	Public Information Services (Tier III)	Lump	SUM	---	\$ _____
45	627-30410	Preformed Thermoplastic Pavement Marking (Xwalk-Stop Line)	708.	SF	\$ _____	\$ _____

Bid Schedule: Grand Junction Horizon Drive Crosswalks

Contractor: _____

Item No.	CDOT, City Ref.	Description	Quantity	Units	Unit Price	Total Price
46	630-00000	Flagging	100.	HR	\$ _____	\$ _____
47	630-00007	Traffic Control Inspection	20.	DAYS	\$ _____	\$ _____
48	630-00012	Traffic Control Management	20.	DAYS	\$ _____	\$ _____
49	630-80341	Construction Traffic Sign (Panel Size A)	16.	EA	\$ _____	\$ _____
50	630-80342	Construction Traffic Sign (Panel Size B)	26.	EA	\$ _____	\$ _____
51	630-80344	Construction Sign Panel (Special)	21.	SF	\$ _____	\$ _____
52	630-80358	Advance Warning Flashing or Sequencing Arrow Panel (Type C)	2.	EA	\$ _____	\$ _____
53	630-80359	Portable Message Sign Panel	20.	DAYS	\$ _____	\$ _____
54	630-80360	Drum Channelizing Device	40.	EA	\$ _____	\$ _____
55	630-80363	Drum Channelizing Device (With Light) (Flashing)	60.	EA	\$ _____	\$ _____
MCR		Minor Contract Revisions	---	---	---	\$ 10,000.00

Bid Amount: \$ _____

Bid Amount: _____

dollars

The undersigned Bidder proposes to subcontract the following portion of Work:

<u>Name & address of Sub-Contractor</u>	<u>Description of work to be performed</u>	<u>% of Contract</u>
_____	_____	_____
_____	_____	_____
_____	_____	_____
_____	_____	_____

The undersigned Bidder acknowledges the right of the City to reject any and all Bids submitted and to waive informalities and irregularities therein in the City's sole discretion.

By submission of the Bid, each Bidder certifies, and in the case of a joint Bid each party thereto certifies as to his own organization, that this Bid has been arrived at independently, without collusion, consultation, communication, or agreement as to any matter relating to this Bid with any other Bidder or with any competitor.

**COLORADO DEPARTMENT OF TRANSPORTATION
ANTI-COLLUSION AFFIDAVIT**

PROJECT NO.

LOCATION

I hereby attest that I am the person responsible within my firm for the final decision as to the price(s) and amount of this bid or, if not, that I have written authorization, enclosed herewith, from that person to make the statements set out below on his or her behalf and on behalf of my firm.

I further attest that:

1. The price(s) and amount of this bid have been arrived at independently, without consultation, communication or agreement for the purpose or with the effect of restricting competition with any other firm or person who is a bidder or potential prime bidder.
- 2A. Neither the price(s) nor the amount of this bid have been disclosed to any other firm or person who is a bidder or potential prime bidder on this project, and will not be so disclosed prior to bid opening.
- 2B. Neither the prices nor the amount of the bid of any other firm or person who is a bidder or potential prime bidder on this project have been disclosed to me or my firm.
- 3A. No attempt has been made to solicit, cause or induce any firm or person who is a bidder or potential prime bidder to refrain from bidding on this project, or to submit a bid higher than the bid of this firm, or any intentionally high or non-competitive bid or other form of complementary bid.
- 3B. No agreement has been promised or solicited for any other firm or person who is a bidder or potential prime bidder on this project to submit an intentionally high, noncompetitive or other form of complementary bid on this project.
4. The bid of my firm is made in good faith and not pursuant to any consultation, communication, agreement or discussion with, or inducement or solicitation by or from any firm or person to submit any intentionally high, noncompetitive or other form of complementary bid.
5. My firm has not offered or entered into a subcontract or agreement regarding the purchase or sale of materials or services from any firm or person, or offered, promised or paid cash or anything of value to any firm or person, whether in connection with this or any other project, in consideration for an agreement or promise by any firm or person to refrain from bidding or to submit any intentionally high, noncompetitive or other form of complementary bid or agreeing or promising to do so on this project.
6. My firm has not accepted or been promised any subcontract or agreement regarding the sale of materials or services to any firm or person, and has not been promised or paid cash or anything of value by any firm or person, whether in connection with this or any other project, in consideration for my firm's submitting any intentionally high, noncompetitive or other form of complementary bid, or agreeing or promising to do so, on this project.
7. I have made a diligent inquiry of all members, officers, employees, and agents of my firm with responsibilities relating to the preparation, approval or submission of my firm's bid on this project and have been advised by each of them that he or she has not participated in any communication, consultation, discussion, agreement, collusion, or other conduct inconsistent with any of the statements and representations made in this affidavit.
8. I understand and my firm understands that any misstatement in this affidavit is and shall be treated as a fraudulent concealment from the Colorado Department of Transportation, of the true facts relating to submission of bids for this contract.

I DECLARE UNDER PENALTY OF PERJURY IN THE SECOND DEGREE, AND ANY OTHER APPLICABLE STATE OR FEDERAL LAWS, THAT THE STATEMENTS MADE ON THIS DOCUMENT ARE TRUE AND COMPLETE TO THE BEST OF MY KNOWLEDGE.

Contractor's firm or company name	By	Date
	Title	
2nd contractor's firm or company name. (If joint venture.)	By	Date
	Title	

Sworn to before me this _____ day of, _____ 20____

Notary Public

My commission expires

NOTE: This document must be signed in ink.

PROJECT SPECIAL PROVISIONS

COLORADO
DEPARTMENT OF TRANSPORTATION
SPECIAL PROVISIONS
Grand Junction Horizon Drive Crosswalks Project

The 2017 Standard Specifications for Road and Bridge Construction controls construction of this project. The following special provisions supplement or modify the Standard Specifications and take precedence over the Standard Specifications and plans.

PROJECT SPECIAL PROVISIONS

	<u>Page</u>
Index Pages	(August 1, 2018) 1
Notice to Bidders	(August 1, 2018) 2-3
Commencement and Completion of Work	(August 1, 2018) 4
Disadvantaged Business Enterprise (DBE) Contract Goal	(August 1, 2018) 5
On the Job Training Contract Goal	(August 1, 2018) 6
Revision of Section 202 – Removal of Asphalt Mat	(August 1, 2018) 7
Revision of Section 213 – Mulching	(August 1, 2018) 8
Revision of Section 304 – Aggregate Base Course	(August 1, 2018) 10-11
Revision of Section 608 – Detectable Warnings	
Revision of Section 614 – Rectangular Rapid Flashing Beacon Assembly	(August 1, 2018) 12-15
Force Account Items	(August 1, 2018) 16

NOTICE TO BIDDERS

The proposal guaranty shall be a certified check, cashier's check, or bid bond in the amount of 5 percent of the Contractor's total bid.

Pursuant to subsections 102.04 and 102.05, it is recommended that bidders on this project review the work site and plan details with an authorized City representative. Prospective bidders shall contact one of the following listed authorized City representatives at least 12 hours in advance of the time they wish to go over the project.

City Public Works Director -

Trent Prall
Office Phone: 970-256-4047
Email: trentonp@gjcity.org

Project Manager -

Jerod Timothy
Office Phone: 970-244-1565
Cell Phone: 970-216-7482
Email: jerodt@gjcity.org

City Buyer -

Duane Hoff
Office Phone: 970-244-1545
Email: duaneh@gjcity.org

The above referenced individuals are the only representatives of the City with authority to provide any information, clarification, or interpretation regarding the plans, specifications, and any other contract documents or requirements.

A mandatory pre bid conference will be held on Thursday, August 16, 2018 beginning at 10:30 am in the City Hall Auditorium at City Hall. Bids will be accepted only from pre-qualified bidders who attend the mandatory pre-bid conference.

Questions received from bidders along with City's responses will be posted on Rocky Mountain Bid Net and the City of Grand Junction's website in the Bids section and will be listed as Addenda. Below is the link to the website: <http://www.gjcity.org/bids.aspx>

If the bidder has a question or requests clarification that involves the bidder's innovative or proprietary means and methods, phasing, scheduling, or other aspects of construction of the project, the Project Engineer will address the question or clarification. The Project Engineer will keep the bidder's innovation confidential and will not share this information with other bidders.

The Project Engineer will determine whether questions are innovative or proprietary in nature. If the Project Engineer determines that a question does not warrant confidentiality, the bidder may withdraw the question. If the bidder withdraws the question, the Project Engineer will not answer the question and the question will not be documented in an Addendum on the City's web site. If the bidder does not withdraw the question, the question will be answered, and both the question and the City's answer will be posted on the web site within an Addendum. If the Project Engineer agrees that a question warrants confidentiality, the Project Engineer will answer the question, and keep both question and answer confidential. The City will keep a record of both question and answer in their confidential file.

Federal Aid Project No.: SHO M555-033
Project Code: 22497

July 31, 2018

All comments and questions shall be directed to the Project Engineer and the City Buyer listed above prior to 5:00 P.M. on Wednesday, August 22, 2018. Final questions and answers will be posted no later than Tuesday morning of bid opening week.

Questions and answers shall be used for reference only and shall not be considered part of the Contract.

COMMENCEMENT AND COMPLETION OF WORK

The Contractor shall complete all work within 33 calendar days in accordance with the "Notice to Proceed."

Completion is achieved when site clean-up and all punch list items (resulting from the final inspection) have been completed. Final Completion shall be the date upon which the Work, in the City's opinion and based upon its inspection, is acceptable and fully performed in accordance with the Contract Documents, and all other requirements or conditions to the City's advertisement of the Project for final payment have been fulfilled. Final Completion shall be evidenced by the City's issuance of a Letter of Final Acceptance.

The anticipated schedule for the Project is as follows:

Invitation for Bids available	August 10, 2018
Mandatory Pre-Bid Meeting	August 16, 2018
Inquiry deadline, no questions after this date	August 22, 2018
Addendum Posted	August 24, 2018
Submittal deadline for proposals (Bid Opening)	August 29, 2018
City Council Approval	September 19, 2018
Notice of Award & Contract execution	TBD
Bonding & Insurance Cert due	TBD
Preconstruction meeting	September 24, 2018
Work begins	October 8, 2018
Substantial Completion	November 2, 2018
Final Completion	82 Calendar Days from Notice to Proceed

Section 108 of the Standard Specifications is hereby revised for this project as follows:

Subsection 108.03 shall include the following:

Salient features for this project are:

- (1) Clearing and Grubbing
- (2) Preliminary BMP's installation
- (3) Concrete work
- (4) Pedestrian/Street light installation
- (5) Inorganic mulch installation
- (6) Striping and Signage

Disadvantaged Business Enterprise (DBE) Contract Goal

This is a federally-assisted construction project. As described in the CDOT DBE Standard Special Provision, the Bidder shall make good faith efforts to meet the following contract goal:

6 Percent DBE participation.

ON THE JOB TRAINING CONTRACT GOAL

The Department has determined that On the Job Training shall be provided to trainees with the goal of developing full journey workers in the types of trade or classification involved. The contract goal for On the Job Trainees working in an approved training plan in this Contract has been established as follows:

Minimum number of total On the Job Training required 0 hours

REVISION OF SECTION 202
REMOVAL OF ASPHALT MAT

Section 202 of the Standard Specifications is hereby revised for this project as follows:

Subsection 202.01 shall include the following:

This work includes removal and disposal of existing asphalt mat within the project limits as shown on the plans or at locations directed by the Engineer.

In subsection 202.02 shall include the following:

The existing asphalt mat shall be saw cut neat at full depth (+/-8" Thick) and removed in a manner as to not damage new asphalt overlay. Any damage to the existing asphalt shall be patched back at the expense of the contractor. The removed mat shall become the property of the Contractor and shall be disposed of outside the project site.

REVISION OF SECTION 213
MULCHING

Section 213 of the Standard Specifications is hereby revised for this project as follows:

Subsection 213.02 shall include the following:

Inorganic Mulch for landscape mulch shall be 1-1/2 inch tan granite rock, River Cobble or washed rock as is naturally available in the region. Rock mulch shall be free of trash, sticks or roots. Submit sample to the Project Engineer for approval at least 10 days prior to placing on project.

Subsection 213.03 shall include the following:

(g) *Inorganic Mulch (Decorative)*. A 4-inch thick layer of aggregate shall be uniformly applied to all landscape beds as shown on the plans or as directed.

Subsection 213.04 shall include the following:

The quantity of inorganic mulch will not be measured but shall be the quantity designated in the contract, except that measurements will be made for revisions requested by the Engineer, or for discrepancies of plus or minus five percent of the total quantity designated in the Contract.

Subsection 213.05 shall include the following:

Payment will be made under:

Pay Item	Pay Unit
Inorganic Mulch (3/4" Washed Rock)	Cubic Yard
Inorganic Mulch (River Cobble)	Cubic Yard
Inorganic Mulch (1 1/2" Tan Granite)	Cubic Yard

REVISION OF SECTION 304
AGGREGATE BASE COURSE

Section 304 of the Standard Specifications is hereby revised for this project as follows:

Subsection 304.02 shall include the following:

Materials for the base course shall be Aggregate Base Course (Class 6) as shown in subsection 703.03.

The aggregate base course (Class 6) must meet the gradation requirements and have a resistance value of at least 78 respectively when tested by the Hveem Stabilometer method.

Subsection 304.08 shall include the following:

The accepted quantities of aggregate base course, of the class specified, will be paid for at the contract price bid per ton as shown in the bid schedule.

The contract unit price for aggregate base course, of the class specified, shall include hauling and disposal of any unsuitable structure excavated material.

1
REVISION OF SECTION 608
DETECTABLE WARNINGS

Section 608 of the Standard Specifications is hereby revised for this project as follows:

Subsection 608.01 shall include the following:

This work includes the installation of detectable warnings on concrete curb ramps as shown on the plans.

Subsection 608.02 shall include the following:

Detectable warnings on curb ramps shall be truncated domes of the dimensions shown on the plans. Domes shall be prefabricated by the manufacturer as a pattern on embeddable surface plates, concrete pavers, or masonry pavers.

Plates and pavers shall meet all Americans with Disabilities Act (ADA) requirements for truncated domes, and when installed, shall be capable of producing the pattern of domes shown on the plans.

Pavers shall meet the requirements of ASTM C 902 or ASTM C 936.

Plates used shall be one of the products approved for use as detectable warnings listed on CDOT's Approved Products List.

The domes and their underlying surface shall have a discernible contrast of color from the adjacent surface. The contrasting colors shall not be black and white.

The paver contrast shall be achieved by adding pigment during the fabrication of the paver. Prior to the start of work, the Contractor shall submit appropriate documentation from the manufacturer verifying that the contrast has been met, along with a sample paver, to the Engineer for approval.

When plates are used, prior to the start of work, the Contractor shall submit appropriate documentation from the manufacturer verifying that the contrast has been met, along with a sample plate, to the Engineer for approval.

Bedding and joint sand for pavers shall be free of deleterious or foreign matter. The sand shall be natural or manufactured from crushed rock. Limestone screenings or stone dust shall not be used. Sand for bedding material shall conform to ASTM C 33. Sand that is to be placed between joints shall conform to ASTM C 144.

Subsection 608.03 shall include the following:

(g) *Detectable Warnings for curbs ramps.*

1. Pavers. Pre-fabricated pavers for detectable warnings shall be brought to the site in steel banded, plastic banded or plastic wrapped cubes capable of being transported by a fork lift or clamp lift. Pavers shall be carefully removed and stacked in a manner which results in the least amount of damage. All pavers that are damaged during transport or delivery will be rejected and shall be replaced at the Contractor's expense. Minor cracks or chipping due to transport and handling that do not interfere with the structural integrity of the paver or the overall pattern of truncated domes will not be deemed as grounds for rejection.

2
REVISION OF SECTION 608
DETECTABLE WARNINGS

The Contractor shall spread the bedding sand evenly in the area shown on the plans and shall screed the sand to an appropriate embedment depth as shown on the plans or as directed by the Engineer. Sufficient sand shall be placed to stay ahead of laid pavers

Pavers shall be placed in a running bond pattern. Pavers shall be installed such that the base of the truncated dome is at the same elevation as the adjoining surface, allowing for a smooth transition between the curb ramp and the detectable warning.

When cut pavers are required to fill gaps between the pavers and the edge of concrete, the Contractor shall bevel portions of the truncated domes at a 45-degree angle to create a smooth transition between the partial dome and the curb ramp surface. Unless otherwise directed by the Engineer, pavers shall be cut and installed in such a manner that the domes on the cut sections will not significantly impact the overall pattern of the truncated domes.

The Contractor shall use a plate vibrator to embed the pavers into the sand. The size and type of plate vibrator shall be in accordance with manufacturer's recommendations, or as directed by the Engineer. All pavers that are damaged during embedment shall be replaced at the Contractor's expense.

Joint spacing between paver units shall be in accordance with the manufacturer's recommendations, or as approved by the Engineer. Joints shall be filled completely with joint sand. Excess sand shall be removed by sweeping.

2. Plates. Prior to installation of the plates, concrete conforming to subsection 608.02 shall be installed and consolidated as a base for the plates. The concrete shall be placed to a thickness that will allow the base surface of the plates to be at the same elevation as the adjacent concrete. The plates shall be embedded into the plastic concrete in accordance with the manufacturer's specifications.

Subsection 608.05 shall include the following:

Detectable warnings on curb ramps, including sand, pavers, plates, and all other work and materials necessary for fabrication, transport, and installation will not be measured and paid for separately, but shall be included in the work.

1
REVISION OF SECTION 614
RECTANGULAR RAPID FLASHING BEACON ASSEMBLY

Section 614 of the Standard Specifications is hereby revised for this project as follows:

Subsection 614.01 shall include the following:

This work includes the installation of rectangular rapid flashing beacon system as shown on the plans.

Subsection 614.02 shall include the following:

**Purchase Specification
for a
AC-Powered Cabinet-Based Rectangular Rapid Flashing
Beacon (RRFB)**

1.0 Overview

Each RRFB shall be cabinet-based and use AC power. The industry-standard cabinet will house the AC/DC power supply, circuit breaker, charge controller, flash controller, on-board user interface, and wireless communications. Each RRFB shall include from one to four lightbars. The RRFB shall conform to all provisions of the MUTCD, Interim Approval IA-11 including flash pattern. The RRFB shall be pre-wired to the maximum extent possible. The manufacturer shall also offer solar versions of the RRFB that are fully compatible.

2.0 Mechanical Specifications

The cabinet shall be constructed from aluminum. No other external control cabinet shall be required.

The cabinet dimensions shall not exceed 20" (50.8cm) in height, 11" (28cm) in width, and 7" (17.8cm) in depth.

The overall weight of the cabinet assembly (including AC/DC power supply, circuit breaker, and EMS control board but not including lightbars, pushbuttons, or talking pushbutton system) shall not exceed 25 lbs. (11.4 kg).

The cabinet shall have a tamper-proof lockable latch.

The cabinet shall be vented to provide cooling of the interior and electronics. The vents shall be screened to prevent ingress by insects and debris.

The lightbars shall be current-driven LED strings without active electronics. The LEDs shall be driven by pulse-width modulated fixed current.

The lightbar housing shall be constructed from aluminum and shall have the approximate dimensions: 24" L x 1.5" D x 4.5" H (61.0 cm L x 3.8 cm D x 11.4 cm H).

Each lightbar shall conform to all provisions of the MUTCD and FHWA requirements.

Each of the two modules in a lightbar shall have 8 LEDs and shall be purpose-built by the manufacturer of the RRFB including the optics. The optics shall be premium, UV-resistant polycarbonate.

Each end of a lightbar shall include a side-emitting pedestrian confirmation light composed of a single LED. Users shall have the option of using both confirmation lights for median applications, or covering one confirmation light with an included sticker for side-of-road applications.

The lightbar shall be mounted to the post or pole using a separate bracket assembly to facilitate mounting two lightbars back-to-back (bi-directional) and to allow the lightbar(s) to rotate horizontally for aiming.

The lightbar bracket shall be constructed from galvanized or stainless steel and shall have both banding and bolting mounting options and shall be able to be mounted to all specified pole types.

The lightbar assembly shall open for access to the wiring connections for the LED modules. LED modules shall be rated to NEMA 3R.

Lightbar wiring harnesses shall be included.

Fasteners shall be stainless steel.

3.0 Mounting

Mounting adapter hardware for the RRFB cabinet shall be available for 4" – 4.5" round poles or square posts. Mounting shall offer strapping as standard with an option for Z-bar and U-bolts.

Mounting shall not require specialized tools.

4.0 Configuration

The RRFB cabinet shall house an auto-scrolling LED on-board user interface that provides on-site configuration adjustment, system status and fault notification.

The user interface shall provide a display of four (4) alphanumeric characters and three (3) control buttons to navigate and change settings, and activate functions.

When editing the configuration, the user interface will flash the display indicating it is ready to accept editing, and will flash the display rapidly 3 times to indicate the setting change has been accepted.

The flash duration shall be adjustable in-the-field from 5 to 60 seconds in one second increments, 60 to 1,200 seconds in 60-second steps, and 3,600 seconds. Default flash duration shall be 20 seconds.

The system shall provide configurable nighttime intensity settings.

The system shall be capable of enabling or disabling ambient brightness auto-adjustment. This feature allows the system to provide optimal output brightness in relation to ambient light levels.

The User Interface shall provide viewing and/or programming access for the following:

- Activation Duration
- Flash Pattern
- Radio Channel (Choice of 1 to 14)
- Radio Status
- Night Intensity Setting
- Adjustment for Ambient Daytime Brightness
- Self-Test / BIST (Built-In Self-Test)
- Number of circular beacons attached
- LED Beacon Error (Open or Shorted)
- Battery Status – General description and actual battery voltage
- Day or Night Status
- Solar Panel Voltage

- Automatic Light Control. If this safety feature is enabled, it allows the Circular Beacon System to temporarily reduce the intensity of the beacons to maintain energy equilibrium.
- Daily activations averaged over 90 days
- Pushbutton detection
- Firmware Version number

Activation duration, Night intensity setting and adjustment for ambient daytime brightness shall be automatically broadcast to all RRFBs in the system when changed in one RRFB.

5.0 AC/DC Power Supply

The RRFB shall include an AC/DC power supply that accepts conventional AC power input and outputs 15 volts DC. It shall be rated for at least 50 watts. AC wiring input shall terminate on a DIN-rail circuit breaker rated for 4 amps

6.0 Operational Specifications

The RRFB shall meet the minimum photometric specifications of the Society of Automotive Engineers (SAE) standard J595 Class I dated January 2005. A photometric report by a certified third-party testing laboratory shall be provided to demonstrate compliance with J595.

The color of the yellow lightbar indications shall meet the specifications of SAE standard J578 (Color Specification) dated December 2006.

The system shall use a dedicated light sensor to detect night and day states and apply any optionally-enabled intensity adjustments.

The system shall operate normally within the temperature range of -40 to +161°F (-40 to +72°C)

7.0 Radio System

The radio system shall operate at 2.4GHz

Upon detection of a pushbutton press, an RRFB will broadcast an activation to all other nearby RRFBs sharing the same channel.

The RRFB shall have the capability to activate other RRFBs by wireless communications within 500 feet (152 meters).

The RRFB shall have a minimum of 14 unique channels that can be configured on-site to avoid inadvertent activation of nearby systems.

The antenna shall be a low-profile “button” shape that cannot be bent or broken by vandals

8.0 Activations

The system shall be capable of activation by pushbutton and passive microwave detection.

The pedestrian push buttons that shall have an LED indicator with audible tone with Piezo control and shall be ADA compliant and MUTCD-2009 4E compliant for momentary operation. The RRFB shall be capable of operating with either 1 or 2 pushbuttons.

The RRFB shall be available with:

- Polara XAVCU2 talking pushbutton control system and the XAV2E audible pushbutton
- Campbell Guardian Talking Pushbutton
- MS Sedco Smartwalk

Custom voice chips shall be available for the XAV2E talking pushbutton.

All RRFBs in the system shall initiate activation simultaneously within 150ms of activation.

If an additional activation occurs while the system is activated, the flash duration shall reset. For example, with the flash duration set to 20 seconds, if an additional activation occurs after the RRFB has been activated for 15 seconds the RRFB will continue for an additional 20 seconds, or 35 seconds in total.

If the RRFB has ceased operation, any subsequent activation shall activate the RRFB without delay regardless of how recently the RRFB ceased operation.

Pushbutton wiring harnesses shall be included.

9.0 Environmental Testing

The RRFB cabinet and lightbars shall be rated to a minimum of NEMA 3R.

10.0 Packaging

Packaging shall consist of only recyclable corrugated cardboard and soft plastic bags.

11.0 Qualifications

The RRFB shall be FCC certified to comply with all 47 CFR FCC Part 15 Subpart B Emission requirements.

The RRFB shall be manufactured in the USA and shall be Buy American compliant.

Manufacturer shall provide a 5-Year Limited Warranty.

The Manufacturer shall be ISO 9001 certified.

Subsection 614.13 shall include the following:

Rectangular Rapid Flashing Beacon Systems will be measured by the number of systems installed and shall include three 15' aluminum pedestal poles (pole, base collar, cap and anchor bolts), four SC315-AC controller enclosure (NON APS Buttons), four RRFB light bar's, four RRFB light bar wiring harnesses, four PED button stations (NON APS), four PED button wiring harnesses, and two Remote Push Button Activation Station Assemblies. Each system shall also include mounting brackets required for the installation of signs and RRFB's to existing street light poles and any other appurtenances necessary for the completion of work.

Subsection 614.14 shall include the following:

Pay Item	Pay Unit
Rectangular Rapid Flashing Beacon System	EA

FORCE ACCOUNT ITEMS

DESCRIPTION

This special provision contains the Department's estimate for force account items included in the Contract. The estimated amounts marked with an asterisk will be added to the total bid to determine the amount of the performance and payment bonds. Force Account work shall be performed as directed by the Engineer.

BASIS OF PAYMENT

Payment will be made in accordance with subsection 109.04. Payment will constitute full compensation for all work necessary to complete the item.

Force account work valued at \$5,000 or less, that must be performed by a licensed journeyman in order to comply with federal, state, or local codes, may be paid for after receipt of an itemized statement endorsed by the Contractor.

<u>Force Account Item</u>	<u>Estimated Quantity</u>	<u>Amount</u>
F/A Minor Contract Revisions	F.A.	\$8,000.00
F/A Sprinklers	F.A.	\$1,000.00
F/A Partnering	F.A.	\$1,000.00

F/A Minor Contract Revisions – This work consists of minor work authorized and approved by the Engineer, which is not included in the Contract plans or specifications and is necessary to accomplish the scope of work of this Contract. This F/A item shall be included in the bonds.

F/A Sprinklers – This force account will be used to reimburse the Contractor labor and supplies used to repair and relocate private irrigation systems.

STANDARD SPECIAL PROVISIONS

DISADVANTAGED BUSINESS ENTERPRISE (DBE)
REQUIREMENTS (LOCAL AGENCY)

SSP Index SHO- M555-033
Project Code 22497

COLORADO
DEPARTMENT OF TRANSPORTATION
SPECIAL PROVISIONS
Grand Junction Horizon Drive Crosswalks
STANDARD SPECIAL PROVISIONS

Name	Date	No. of Pages
Revision of Section 103 – Consideration of Proposals	(July 3, 2017)	1
Revision of Section 106 – Supplier List	(July 3, 2017)	1
Revision of Section 107 – Laws to be Observed	(October 12, 2017)	1
Revision of Sections 107 and 208 – Water Quality Control under One Acre of Disturbance	(November 2, 2017)	4
Revision of Section 108 – Liquidated Damages	(July 20, 2017)	1
Revision of Section 108 - Payment Schedule (Single Fiscal Year)	(July 3, 2017)	1
Revision of Section 108 – Subletting of Contract	(October 12, 2017)	1
Revision of Section 109 – Prompt Payment (Local Agency)	(July 3, 2017)	2
Revision of Section 250 – Environmental, Health and Safety Management	(July 3, 2017)	3
Revision of Section 614 – Accessible Pedestrian Signal	(July 3, 2017)	3
Revision of Section 625 – Construction Surveying	(July 3, 2017)	1
Revision of Section 703 - Classification for Aggregate Base Course	(October 12, 2017)	1
Affirmative Action Requirements – Equal Employment Opportunity	(July 3, 2017)	10
Disadvantaged Business Enterprise (DBE) Requirements (Local Agency)	(July 3, 2017)	9
Minimum Wages, Colorado, U.S. Department of Labor General Decision Number CO180024	(January 5, 2018)	7
Highway Construction for Larimer, Mesa, and Weld counties. Partnering Program	(July 3, 2017)	1
Required Contract Provisions – Federal-Aid Construction Contracts	(July 3, 2017)	14
Special Construction Requirements, Fire Protection Plan	(July 3, 2017)	2

July 3, 2017

REVISION OF SECTION 103
CONSIDERATION OF PROPOSALS

Section 103 of the Standard Specifications is hereby revised for this project as follows:

Delete subsection 103.01 and replace with the following:

103.01 Consideration of Proposals. After the proposals (bids) are opened and read, they will be evaluated and the Contract awarded or rejected in accordance with the "Rules" referenced in subsection 102.01

The low responsible bidder shall submit a completed CONTRACTORS PERFORMANCE CAPABILITY STATEMENT, Form 605, and a completed ASSIGNMENT OF ANTITRUST CLAIMS, Form 621 to the Award Officer prior to 4:30 P.M. on the fifth calendar day after the bid opening.

In order to be eligible for contracting with CDOT, the apparent low responsible bidder shall register with the B2GNow software system on or before the fifth calendar day after the bid opening and shall update the registration on an annual basis.

Failure to submit the Forms 605 and 621 and to register with the B2G Now software system may result in the denial of award to the apparent low responsible bidder and forfeiture of the proposal guaranty.

July 3, 2017

REVISION OF SECTION 106
SUPPLIER LIST

Section 106 of the Standard Specifications is hereby revised for this project as follows:

In subsection 106.01 delete the fourth and 5th paragraphs and replace with the following:

All companies that will provide \$10,000 or more in supplies or materials on any CDOT project must be registered in the B2GNow software system and shall update the registration on an annual basis.

Prior to beginning any work on the project, the Contractor shall submit to the Engineer a completed Form 1425, Supplier List documenting all companies providing \$10,000 or more of supplies or materials directly to the Contractor for the project. This list shall not include companies also responsible for the installation of the supplies or materials. During the performance of the project, the Contractor shall submit an updated Form 1425 if one or more of these companies change.

The Contractor shall require each subcontractor to submit a Form 1425 listing all companies providing \$10,000 or more of supplies or materials to the subcontractor. The Contractor shall submit the subcontractor's Form 1425 with Form 205.

Failure to comply with the requirements of this subsection shall be grounds for withholding of progress payments.

October 12, 2017

REVISION OF SECTION 107
LAWS TO BE OBSERVED

Section 107 of the Standard Specifications is hereby revised for this project as follows:

Subsection 107.01 shall include the following after the first paragraph:

Failure to comply with all contractual obligations may lead to the suspension, debarment or both of the Contractor as stipulated in the "Rules".

November 2, 2017

5
REVISION OF SECTIONS 107 AND 208
WATER QUALITY CONTROL
UNDER ONE ACRE OF DISTURBANCE

Sections 107 and 208 of the Standard Specifications are hereby revised for this project as follows:

In subsection 107.25(b) 6 delete the second paragraph and replace it with the following:

The Contractor shall record the location of potential pollutants on the plans. Descriptions of the potential pollutants shall be submitted for approval.

Delete subsection 107.25 (c) and replace with the following:

A Colorado Discharge Permit System Stormwater Construction Permit (CDPS-SCP) is not required for this project.

The Engineer will coordinate with CDOT Maintenance and the Region Water Pollution Control Manager prior to initiating partial or final acceptance of the stormwater construction work, including soil conditioning and seeding for permanent stabilization. Unsatisfactory and incomplete erosion control work will be identified in this walkthrough, and will be summarized by the Engineer in a punch list.

In subsection 208.01 delete the third paragraph and replace with the following:

When a provision of Section 208 or an order by the Engineer requires that an action be immediate or taken immediately, it shall be understood that the Contractor shall at once begin effecting completion of the action and pursue it to completion, as approved.

In subsection 208.03, delete the first and second paragraphs.

Delete subsection 208.03 (b) and replace with the following:

(b) *Erosion and Sediment Control Activities.* The erosion and sediment control activities shall be included in the weekly meeting update. The project schedule shall specifically indicate the sequence of clearing and grubbing, earthwork operations, and construction of temporary and permanent erosion control features and stabilization. The project schedule shall include erosion and sediment control work for haul roads, borrow pits, storage and asphalt or concrete batch sites, and all areas within the project limits. If during construction the Contractor proposes changes which would affect the Contract's BMPs, the Contractor shall propose revised BMPs to the Engineer for approval in writing.

In subsection 208.03, delete (c), (d) and (e) and replace with the following:

(c) *SWMP Administrator.* The Contractor shall assign to the project an individual to serve in the capacity of SWMP Administrator. These duties may be assumed by the Superintendent. The SWMP Administrator shall have working knowledge and experience in construction and have satisfactorily completed the Transportation Erosion Control Supervisor Certification (TECS) training provided by the Department. Proof that this requirement has been met shall be submitted to the Engineer prior to start of work. The SWMP Administrator shall:

- (1) Ensure the Method Statement for Containing Pollutant Byproducts is implemented.
- (2) Review the construction site for compliance with CDOT specifications and the SWMP.
- (3) Follow all stormwater requirements and inspections for other applicable State and local agencies unless a waiver or other agreement has been made.
- (4) Immediately report to the Contractor and Engineer the following instances of noncompliance:
 - (i) Noncompliance which may endanger health or the environment.
 - (ii) Spills or discharge of hazardous substance or oil which may cause pollution of waters of the State.
 - (iii) Discharge of stormwater which may cause an exceedance of a water quality standard.

(iv) Discharge of pollutants that have occurred on site.

November 2, 2017

2

REVISION OF SECTIONS 107 AND 208
WATER QUALITY CONTROL
UNDER ONE ACRE OF DISTURBANCE

- (d) *Documentation Available on the Project.* The SWMP Administrator shall provide the following Contract documents and references. They shall be made available for reference in one location on the project during construction. The documents shall be kept in a single notebook:
- (1) SWMP Plan Sheets – Notes, tabulation, sequence of major activities, area of disturbance, existing soil data, existing vegetation percent cover, potential pollutant sources, receiving water, non-stormwater discharges, and environmental impacts.
 - (2) SWMP Site Maps (if included in the original Contract) - Construction site boundaries ground surface disturbance, limits of cut and fill, flow arrows, structural BMPs, non-structural BMPs, springs, streams, wetlands, and surface water. Also included on the map are the protection of trees, shrubs, and cultural resources.
 - (3) BMP Details not in Standard Plans M-208-1, M-216-1 and M-615-1.
 - (4) Spill Response Plan – Reports of reportable spills submitted to CDPHE.
 - (5) List and Evaluation of Potential Pollutants – List of potential pollutants as described in subsection 107.25 and approved Method Statement for Containing Pollutant Byproducts.
 - (6) All Project Environmental Permits-All Project environmental permits and associated applications and certifications, including, Senate Bill 40, USACE 404, dewatering and all other permits applicable to the project, including any separate CDPS-SCP obtained by the Contractor for staging area on private property, asphalt or concrete plant, etc.
 - (7) Form 105 and all other correspondence related to water quality which are issued by the Engineer for Contractor's lack of compliance.

The Contractor shall incorporate the documents and reports and have Items 1-7 available for the first working day of the project. None of these documents are required to be updated during the course of the project.

- (e) *Weekly Meetings.* The Contractor shall conduct weekly meetings with the Engineer to discuss the following:
- (1) Requirements of the SWMP.
 - (2) Problems that may have arisen in implementing the site specific SWMP or maintaining BMPs.
 - (3) Unresolved issues from inspections and concerns from last inspection
 - (4) BMPS that are to be installed, removed, modified, or maintained.
 - (5) Planned activities that will affect stormwater in order to proactively phase BMPs.
 - (6) Recalcitrant inspection findings.

Delete the third paragraph in subsection 208.04 and replace with the following:

New inlets and culverts shall be protected during their construction. Appropriate protection of each culvert and inlet shall be installed immediately after installation of the culvert or inlet. When riprap is called for at the outlet of

a culvert, it shall be installed within 24 hours of completion of each pipe. The Contractor shall remove sediment, millings, debris, and other pollutants from within the newly constructed drainage system prior to use, at the Contractor's expense. All removed sediment shall be disposed of in accordance with all applicable regulations.

3
REVISION OF SECTIONS 107 AND 208
WATER QUALITY CONTROL
UNDER ONE ACRE OF DISTURBANCE

Delete the first paragraph in subsection 208.04 (f) and replace with the following:

- (f) *Maintenance*. Erosion and sediment control practices and other protective measures identified in the SWMP as BMPs for stormwater pollution prevention shall be maintained in effective operating condition until final acceptance of the project. BMPs shall be continuously maintained in accordance with good engineering, hydrologic and pollution control practices, including removal of collected sediment when silt depth is 50 percent or more of the height of the erosion control device. When possible, the Contractor shall use equipment with an operator rather than labor alone to remove the sediment.

In subsection 208.06, first paragraph, delete the first sentence.

In subsection 208.07, second paragraph, delete the second sentence.

In subsection 208.08, delete the first paragraph and replace with the following:

208.08 Limits of Disturbance. The Contractor shall limit construction activities to those areas within the limits of disturbance shown on the plans and cross-sections. Construction activities, in addition to the Contract work, shall include the on-site parking of vehicles or equipment, on-site staging, on-site batch plants, haul roads or work access, and all other action which would disturb existing conditions. Off road staging areas must be pre-approved by the Engineer, unless otherwise designated in the Contract. Construction activities beyond the limits of disturbance due to Contractor negligence shall be restored to the original condition by the Contractor at the Contractor's expense.

In subsection 208.09, delete the first and second paragraph and replace with the following:

208.09 Failure to Perform Erosion Control. Failure to implement the Stormwater Management Plan is a violation of the Colorado Water Quality Control Act. Penalties may be assessed to the Contractor by the appropriate agencies. Penalties will be assessed by the Department as liquidated damages for failure to meet the contract documents. All fines assessed to the Department for the Contractor's failure to implement the SWMP will be deducted from monies due the Contractor.

The Contractor will be subject to liquidated damages for incidents of failure to perform erosion control as required by the Contract. Liquidated damages will be applied for failure to comply with these specifications, including the following:

- (1) Failure of the Contractor to implement necessary actions required by the Engineer as required by subsection 208.03(b) and (c)
- (2) Failure to construct or implement erosion control or spill containment measures required by the Contract, or failure to construct or implement them in accordance with the Contractor's schedule.
- (3) Failure to stabilize disturbed areas as required by subsections 208.04(e) and 208.08.
- (4) Failure to replace or perform maintenance on an erosion control feature after notice from the Engineer to replace or perform maintenance as required by subsection 208.04(f).
- (5) Failure to remove and dispose of sediment from BMPs as required.
- (6) Failure to install and properly utilize a concrete washout structure for containing washout from concrete placement operations.
- (7) Failure to perform permanent stabilization as required by subsection 208.04 (e).

- (8) Failure to prevent discharges not composed entirely of stormwater from leaving the construction site.
- (9) Failure to provide the survey of Permanent Water Quality BMPs when required on the project in accordance with subsection 208.10.

REVISION OF SECTIONS 107 AND 208
WATER QUALITY CONTROL
UNDER ONE ACRE OF DISTURBANCE

In subsection 208.09, delete the 10th paragraph, and replace with the following:

If the Contractor's corrective action plan and schedule are not submitted and approved within 96 hours of the initial notice, the Engineer will issue a Stop Work Order and have an on-site meeting with the Superintendent, SWMP Administrator, and the Superintendent's supervisor. This meeting will also be attended by the Resident Engineer, the Region Water Pollution Control Manager, and the Region Program Engineer. This meeting will identify and document needed corrective actions and a schedule for completion. If after the meeting, the unacceptable work is not remedied within the schedule as agreed to in the meeting, the Engineer will take action to effect compliance with the Contract and these specifications by utilizing CDOT Maintenance personnel or other non-Contractor forces and deduct the cost from any monies due or to become due to the Contractor pursuant to subsection 105.17. Delays due to these Stop Work Orders shall be considered non-excusable. The Stop Work Order shall be in place until the project is in compliance.

In subsection 208.10, delete (c) and replace with the following:

(c) *Locations of Temporary BMPs*. The Engineer will identify locations where modification, cleaning or removal of temporary BMPs are required, and will provide these in writing to the Contractor.

In subsection 208.11, delete the first paragraph.

In subsection 208.12, delete the third, fourth and fifth paragraphs and replace with the following:

SWMP Administrator duties on projects having less than one acre of total disturbed area will not be measured and paid for separately but shall be included in the work. The Erosion Control Management Pay Item will not apply to this project.

July 20, 2017

REVISION OF SECTION 108
LIQUIDATED DAMAGES

Section 108 of the Standard Specifications is hereby revised for this project as follows:

In subsection 108.09 delete the schedule of liquidated damages and replace with the following:

Original Contract Amount (\$)		Liquidated Damages per Calendar Day (\$)
From More Than	To And Including	
0	500,000	900
500,000	1,000,000	1,500
1,000,000	2,000,000	2,200
2,000,000	5,000,000	4,100
5,000,000	15,000,000	5,500
15,000,000	-----	9,900

July 3, 2017

REVISION OF SECTION 108
PAYMENT SCHEDULE (SINGLE FISCAL YEAR)

Section 108 of the Standard Specifications is hereby revised for this project as follows:

Delete subsection 108.04, and replace with the following:

108.04 Payment Schedule. The Contractor shall prepare a payment schedule which shall show the dollar amount of work the Contractor expects to be complete within a single State Fiscal Year (July 1 to June 30). The schedule shall cover the period from the commencement of work to the expected completion date as shown on the Contractor's progress schedule. The payment schedule may be prepared using standard spreadsheet software such as MS Excel and submitted in electronic format.

The Contractor shall submit the payment schedule at the preconstruction conference.

The amounts shown shall include planned force account work and expected incentive payments.

If the Contractor fails to submit the payment schedule by the required date, the Engineer will withhold further progress payments until such time as the Contractor has submitted it.

October 12, 2017

REVISION OF SECTION 108
SUBLETTING OF CONTRACT

Section 108 of the Standard Specifications is hereby revised for this project as follows:

Subsection 108.01 shall include the following:

Failure to comply with all contractual obligations may lead to the suspension, debarment, or both of the subcontractor, and if necessary, the Contractor as stipulated in the "Rules".

All firms to which the Contractor will be subletting a portion of the Contract must be registered in the B2GNow Software System and shall update the registration on an annual basis. If the firm is not registered, approval of the Form 205 may be withheld.

14
REVISION OF SECTION 109
PROMPT PAYMENT
(LOCAL AGENCY)

Section 109 of the Standard Specifications is hereby revised for this project as follows:

Delete subsection 109.06(e) and replace with the following:

- (e) *Prompt Payment.* The Contractor shall pay subcontractors and suppliers for all work which has been satisfactorily completed within seven calendar days after receiving payment for that work from the Local Public Agency (LPA). For the purpose of this section only, work shall be considered satisfactorily complete when the LPA has made payment for the work. The Contractor shall include in all subcontracts a provision that this requirement for prompt payment to subcontractors and suppliers must be included in all subcontracts at every tier. The Contractor shall ensure that all subcontractors and suppliers at every tier are promptly paid. If the Contractor or its subcontractors fail to comply with this provision, the Engineer will not authorize further progress payment for work performed directly by the Contractor or the noncompliant subcontractor until the required payments have been made. The Engineer will continue to authorize progress payments for work performed by compliant subcontractors.

Delete subsection 109.06(f)5 and replace with the following:

5. In determining whether satisfactory completion has been achieved, the Contractor may require the subcontractor to provide documentation such as certifications and releases, showing that all laborers, lower-tiered subcontractors, suppliers of material and equipment, and others involved in the subcontractor's work have been paid in full. The Contractor may also require any documentation from the subcontractor that is required by the subcontract or by the Contract between the Contractor and the LPA or by law such as affidavits of wages paid, material acceptance certifications and releases from applicable governmental agencies to the extent that they relate to the subcontractor's work.

Delete subsection 109.06(f)8 and replace with the following:

8. If additional quantities of a particular item of work are required at a later date after final measurement has been made, the Contractor shall perform this work in accordance with Contract requirements and at unit bid prices.
For this subsection only, satisfactory completion of all work described on CDOT Form No. 205 is when all tasks called for in the subcontract as amended by changes directed by the Engineer have been accomplished and documented as required by the LPA.
The requirements stated above do not apply to retainage withheld by the LPA from monies earned by the Contractor. The LPA will continue to process the release of that retainage based upon the completion date of the project as defined in the Commencement and Completion of Work special provision.

Delete subsection 109.06(f)9 and replace with the following:

9. If during the prosecution of the project a portion of the work is partially accepted in accordance with subsection 105.21(a), the Contractor shall release all subcontractors' retainage on the portion of the partially accepted work performed by subcontractors. Prior to the LPA releasing the Contractor's retainage on work that has been partially accepted in accordance with subsection 105.21(a), the Contractor shall submit to the Engineer a certified statement for each subcontractor that has participated in the partially accepted work. The statement shall certify that the subcontractor has been paid in full for its portion of the partially accepted work including release of the subcontractor's retainage. The statement shall include the signature of a legally responsible official for the Contractor, and the signature of a legally responsible official for the subcontractor.

Delete subsection 109.06(g) and replace with the following:

Good Cause Exception. If the Contractor has "good cause" to delay or withhold a subcontractor's progress payment, the Contractor shall notify the LPA and the subcontractor in writing within seven calendar days after

receiving payment from the LPA. The notification shall specify the amount being withheld and provide adequate justification for withholding the payment. The notice shall also clearly state what conditions the July 3, 2017

15

REVISION OF SECTION 109
PROMPT PAYMENT
(LOCAL AGENCY)

- (g) subcontractor must meet to receive payment. "Good cause" shall include but not be limited to the failure of the subcontractor to make timely submission of required paperwork.

Delete subsection 109.06(h) and replace with the following:

- (h) *Monthly Reporting.* On a monthly basis, the Contractor shall submit the Form 1418, Monthly Payment Report, to the Engineer along with the project schedule updates, in accordance with subsections 108.03(g). Failure to submit a complete and accurate Form 1418 shall be grounds for CDOT to withhold subsequent payments or retainage from the Contractor.

16
REVISION OF SECTION 250
ENVIRONMENTAL, HEALTH AND SAFETY MANAGEMENT

Section 250 of the Standard Specifications is hereby revised for this project as follows:

In subsection 250.03 delete the second paragraph and replace with the following:

This project may be in the vicinity of property associated with petroleum products, heavy metal based paint, landfill, buried foundations, abandoned utility lines, industrial area or other sites which can yield hazardous substances or produce dangerous gases. These hazardous substances or gases can migrate within or into the construction area and could create hazardous conditions. The Contractor shall use appropriate methods to reduce and control known landfill, industrial gases, and visible emissions from asbestos encounters and hazardous substances which exist or migrate into the construction area. The Contractor shall follow CDOT's *Regulated Asbestos-Contaminated Soil Management Standard Operating Procedure, dated October 18, 2016* for proper handling of asbestos-contaminated soil, and follow all applicable Solid and Hazardous Waste Regulations for proper handling of soils encountered that contain any other substance mentioned above.

In subsection 250.03(a) delete the second paragraph and replace with the following:

When regulated asbestos contaminated soil (RACS) is present or is suspected to be present on or near a project, the HSO shall have knowledge of RACS regulations. The HSO shall meet the minimum training and medical surveillance requirements established by the Occupational Safety and Health Administration (OSHA) and the Environmental Protection Agency (EPA) for a supervisory Site Safety Official per 29 CFR 1962.65. The Contractor shall furnish documentation to the Engineer, at the preconstruction conference, that the above requirements have been met. Certification as an Asbestos Building Inspector in accordance with subsection 250.03 (b) is recommended.

In subsection 250.03(b) delete the first and second paragraphs and replace with the following:

The Contractor shall designate a monitoring technician to be responsible for monitoring of hazardous substances during work on the project. The MT shall have a minimum of two years of actual field experience in assessment and remediation of hazardous substances that may be encountered during highway construction projects. When asbestos is present or is suspected to be present on or near a project, the MT shall have additional 40 hours experience in RACS project management and certification as an Asbestos Building Inspector in accordance with the Colorado Air Quality Control Commission Regulation No. 8 Part B. The MT shall be experienced in the operation of monitoring devices, identifying substances based upon experience and observation, and field sampling (for testing) of all media that may be found on the site. Completion of the 40 hour hazardous waste and 8 hour supervisory training required by OSHA and U.S. EPA rules and regulations which complies with the accreditation criteria under the provisions of the proposed 29 CFR 1910.121 is required prior to beginning work. The Contractor shall furnish documentation at the Preconstruction Conference that demonstrates these requirements have been met.

The MT shall be equipped with the following:

- (1) Communication equipment as required in subsection 250.03(d) 2.A. and a vehicle.
- (2) Monitoring and detection equipment for flammable gas, oxygen sufficiency, toxic gas, radiological screening and other hazards. This includes, as required, a combustible gas indicator, flame ionization or photo ionization detector, oxygen meter, radiation monitor with Geiger Mueller detector and other foreseeable equipment.
- (3) Depth gauging equipment, sampling equipment and sampling containers.
- (4) Personal protective equipment (levels C and D) when required.

Delete subsection 250.07 and replace with the following:

250.07 Regulated Asbestos Contaminated Soils (RACS) Management. Environmental documents or plans listed in the special provisions should include known or suspected locations that could involve encounters with

RACS during excavation and other soil disturbing construction activities. Unexpected discoveries of RACS may occur during excavation and soil disturbing construction activities. RACS shall be properly managed or remediated, in accordance with subsection 250.07(a).

July 3, 2017

2

REVISION OF SECTION 250
ENVIRONMENTAL, HEALTH AND SAFETY MANAGEMENT

All asbestos related activities shall be performed by CDPHE certified asbestos professionals, contractors, or consultants. Certifications are issued by the CDPHE, Indoor Air Quality Unit. A Colorado Certified Asbestos Building Inspector shall manage the assessment and disposal of RACS and other ACM. The Indoor Air Quality Unit within CDPHE is the only unit that certifies such professionals. The Contactor shall furnish a copy of the certification to the Engineer.

- (a) *Regulatory Compliance.* RACS management is governed by 6 CCR 1007-2, Section 5.5, which includes and references regulatory compliance with Colorado Air Quality Control Commission *Regulation* No. 8 Part B-Asbestos. Colorado Regulation No. 8 governs all asbestos activities, demolition, permitting, and certification of Certified Asbestos Professionals in the State of Colorado. The Contractor shall conform to all current regulations, policy directives, or both, issued by the CDPHE, and the Department.
- (b) *Asbestos Management and Visual Inspections* Asbestos management shall be performed by a CDPHE certified asbestos building inspector. All inspections of the area of asbestos contaminated soil removal shall be performed by a CDPHE certified Asbestos Building Inspector to determine what, if any, controls must be instituted to allow future activity in the excavation area.
- (c) *Permitting and Notification.* The CDPHE requires notification of any soil disturbing activity where asbestos is known, suspected, or discovered. A 24-hour notification to CDPHE is required after any soil disturbing activity of an unplanned asbestos discovery. A 10 working day notification to CDPHE is required prior to any soil disturbing activity in an area with known or potential RACS. Removal of asbestos-containing material on a facility component, that is located on or in soil that will be disturbed, with asbestos quantities above the following trigger levels shall be permitted and abated in accordance with the requirements of Colorado Air Quality Control Commission Regulation No. 8 (5 CCR 1001-10, Part B):
 - (1) 260 linear feet on pipes,
 - (2) 160 square feet on other surfaces, or
 - (3) The volume of a 55-gallon drum.

All permit applications shall be submitted to the Colorado Department of Public Health and Environment a minimum of 10 days prior to start of work for approval. The permit application and notification shall be submitted simultaneously. A CDPHE certified General Abatement Contractor shall obtain all required State and local permits and shall be responsible for all associated fees. Permit application, notification, and waiver request forms shall be submitted to:

Colorado Department of Public Health and Environment Permit Coordinator/APCD - SS - B1 4300
Cherry Creek Drive South Denver, CO 80246-1530 Phone: (303) 692-3100 Fax: (303) 782-0278

Application and waiver forms are available on the CDPHE website: asbestos@state.co.us

- (d) *CDOT's Regulated Asbestos-Contaminated Soil Management Standard Operating Procedure, dated October 18, 2016.* Asbestos contaminated soil shall be managed in accordance with 6 CCR 1007-2, Part 1, Section 5.5, Management of RACS. . Regulations apply only upon unexpected discovery of asbestos materials during excavation and soil disturbing activities on construction projects, or when asbestos encounters are expected during construction. The Contractor shall comply with procedures detailed in the *CDPHE's Management of Regulated Asbestos Contaminated Soil Regulation* and CDOT's CDPHE approved *Regulated Asbestos-Contaminated Soil Management Standard Operating Procedure, dated October 18, 2016*, including the following minimum requirements:

- (1) Immediate actions and implementation of interim controls to prevent visible emissions, exposure, and asbestos contamination in surrounding areas.
- (2) Soil Characterization.
- (3) Training required for all personnel involved in excavation and other soil disturbing activities, once asbestos is encountered during construction or on projects where asbestos encounters are expected.

July 3, 2017

3
REVISION OF SECTION 250
ENVIRONMENTAL, HEALTH AND SAFETY MANAGEMENT

Asbestos Awareness Training shall be given by a qualified and certified Asbestos Building Inspector with a minimum of six months experience inspecting asbestos contaminated soil.

- (4) Assessment for the presence and extent, within the proposed area of disturbance, of asbestos discoveries, whether expected or unexpected, by a CDPHE Certified Asbestos Building Inspector.
 - (5) Investigation and sampling required for risk assessment and management. Investigation, if required, shall be conducted by a CDPHE Certified Asbestos Building Inspector.
 - (6) Risk assessment and determinations for further management or abatement.
 - (i) Risk assessment and determinations must be made by a CDPHE Certified Asbestos Building Inspector, and coordinated with the Engineer.
 - (ii) Soil remediation is not necessarily required, depending on the circumstances.
 - (7) Submit CDPHE 24-hour Notification form for unexpected RACS discovery included in Attachment 1 of the CDOT Regulated Asbestos-Contaminated Soil Management Standard Operating Procedure
 - (8) Submit CDPHE 10-day Notification form for planned RACS management included in Attachment 1 of the CDOT Regulated Asbestos-Contaminated Soil Management Standard Operating Procedure.
- (e) Risk Assessment and Determinations for Further Management Or Remediation. Risk assessment and determinations for further management or remediation must be closely coordinated with the Project Engineer and Project Manager of the Statewide Management Plan.*

20
REVISION OF SECTION 614
ACCESSIBLE PEDESTRIAN SIGNAL

Section 614 of the Standard Specifications is hereby revised for this project to include the following:

DESCRIPTION

This work consists of the construction of an accessible pedestrian signal at locations as shown on the plans.

MATERIALS

The Accessible Pedestrian Signal (APS) shall be an audible-tactile pedestrian signal system and shall consist of all electronic control equipment, mounting hardware, push buttons, and signs designed to provide both a pushbutton with a raised, vibrating tactile arrow on the button as well as a variety of audible indications for differing pedestrian signal functions.

The APS shall meet the following requirements:

- (1) 2009 Manual of Uniform Traffic Control Devices (MUTCD), Chapter 4E – Pedestrian Control Features.
- (2) NEMA TS 2 Section 2.1 requirements for Temperature and Humidity, Transient Voltage Protection and Mechanical Shock and Vibration.
- (3) IEC 61000-4-4; 4-5 Transient Suppression requirements.
- (4) FCC Title 47, Part 15, Class A, Electronic Noise requirements.

The APS pushbutton enclosure shall meet the NEMA 250 – Type 4X enclosure requirement.

Upon installation the APS shall meet the following functional requirements:

(a) *APS functional requirements.* The APS shall have the following functional features:

- (1) The APS shall be programmable and adjustable. Programming and adjustments shall be made using a laptop computer or vendor supplied programmer. No additional hardware or equipment shall be required. The APS shall be fully compatible with the three latest versions of the Windows operating platform. The programmable features shall be:
 - (i) Push-button locator tone.
 - (ii) Walk and Wait audible message.
 - (iii) Audible push-button informational message.
 - (iv) Audible crossing beacon.
 - (v) Vibrating tactile arrow.
 - (vi) Independent minimum and maximum volume limits for the Locator Tone, Walk and Audible Beacons features.
- (2) All audible features shall emanate from the pedestrian pushbutton housing. The APS shall utilize digital audio technology, having a minimum 12-bit sample at a 16k Hz sample rate. Total harmonic distortion shall be less than 3 percent at 75 decibels. The APS shall provide independent ambient sound adjustment for the Locator Tone feature. The APS shall allow for Locator Tone volume to be set below the ambient noise level. The system shall have, at a minimum, three programmable locator tones. All sound levels shall adjust automatically utilizing an internally mounted, interval ambient sensing microphone, in accordance with the MUTCD.
- (3) The APS shall monitor the Walk condition for conflict operation. As a standalone unit, the APS shall disable the Walk functionality should a conflict be detected.

Appendix A

Project Submittals

PROJECT SUBMITTAL FORM

PROJECT: **Grand Junction Horizon Drive Crosswalk Project**

CONTRACTOR: _____

PROJECT MANAGER: Jerod Timothy

Description	Date Received	Resubmittal Requested	Resubmittal Received	Date Accepted
-------------	---------------	-----------------------	----------------------	---------------

STREET CONSTRUCTION

Aggregate Base Course gradation, Proctor curve (Class 6)				
Aggregate Base Course gradation, (Class 6)				
Concrete Mix Design (CDOT Class D Concrete)				
Reinforcing Steel				

UTILITY CONSTRUCTION

2 Inch Electrical Conduit (Plastic)				
Rectangular Rapid Flashing Beacon System				
Type One Pull Box				
Wiring				
Light Standard and Luminaire (Pedestrian)				
Light Standard and Luminaire (Street)				
Light Standard Foundation				
Light Control Center (Special)				

EROSION CONTROL/STORMWATER MANAGEMENT

Concrete Washout Facility				
Storm Drain Inlet Protection (Type II)				

PERMITS, PLANS, OTHER

Traffic Control Plan(s)				
Contractor's Construction Schedule				
Hourly Labor and Equipment Rate				

Tables				
Topsoil				
Inorganic Mulch				
Sign Panel (Class I) Fluorescent Yellow Green				
Steel Sign Post (U-2)				
Preformed Thermoplastic Pavement Markings				

APPENDIX B

**CDOT Disadvantage Business Enterprise (DBE) Program Plan
CDOT Forms: 1414, 1415, 1416**

COLORADO DEPARTMENT OF TRANSPORTATION

COMMITMENT CONFIRMATION

SECTION 1. This section must be completed by the Contractor.

Project:		Project Code:	
Bidder/Contractor:		Phone:	
Contact:		Email:	
DBE Firm Name:		DBE Phone:	
DBE Address:		DBE Email:	

Commitment Details

Category	Work to be Performed	DBE Work Code(s)	Commitment Amount	Eligible Participation
Construction				
Trucking				
Supplies				
Services				
Total				

This section must be signed by an individual with the power to contractually bind the Bidder/Contractor. You declare under penalty of perjury in the second degree and any other applicable state or federal laws that the statements made in this document are complete, true and accurate to the best of your knowledge.

Bidder/Contractor Representative	Title	Signature	Date
----------------------------------	-------	-----------	------

SECTION 2. This section must be completed by the DBE. (Attach additional pages if necessary).

This document is not a contract with the Bidder/Contractor; it is an acknowledgement of the obligation that the Bidder/Contractor is making to CDOT. The amounts listed above may be less than the subcontractor or purchase order amount, but can never be more, and shall not reflect any mark up by the Bidder/Contractor. **All questions must be answered.**

Are you contracting directly with the Bidder/Contractor or with one of its subcontractors? If with a subcontractor, provide the firm name.	
Will you be purchasing supplies or materials or leasing or renting equipment from the Bidder/Contractor or its subcontractors? If so, explain.	
Do you intend to subcontract any portion of the work listed above? If yes, state to which firms, what work and the approximate amount. Include trucking subcontractors and owner-operators.	
Will you be providing trucking services on this project? If so, state how many of your own trucks and employees you will have on this project.	
Who within your firm will be supervising and responsible for your firm's work on this project?	
Will you be acting as a broker on this project? If so, state what you will be brokering and your approximate brokerage fee.	
Will you be acting as a supplier on this project? If so, please state what you will be supplying and whether you will manufacture the items.	

This section must be signed by an individual with the power to contractually bind the DBE. You declare under penalty of perjury in the second degree and any other applicable state or federal laws that the statements made in this document are complete, true and to the best of your knowledge. You attest that you are eligible to participate as a DBE on this contract for the work listed above and have the capacity to perform the work as stated.

DBE Representative	Title	Signature	Date

See the DBE Standard Special provision for additional information on completing and submitting this form.

Pre-award CDOT projects: Submit this form to the CDOT Civil Rights and Business Resource Center via fax to (303)757-9019. All originals must be sent to: CDOT Civil Rights and Business Resource Center, 4201 E. Arkansas Ave. Room 150, Denver, CO 80222.

Pre-award local agency projects: Submit this form to the local agency. All originals must be sent to: CDOT Civil Rights and Business Resource Center, 4201 E. Arkansas Ave. Room 150, Denver, CO 80222.

APPENDIX C

Special Notice to Contractors

Special Notice to Contractors - 18

1. SCOPE

1.1 It is the intent of this chapter to provide guidelines to the Contractor or Sub-Contractor, so that they can properly present their materials for inclusion in the construction project.

1.2 The Contractor shall follow the procedures listed below to ensure the proper inspection, sampling, testing, and certification of materials and products incorporated into all construction projects.

1.3 "Prequalification of Bidders" (Standard Specifications, Subsection 102.01) is synonymous with any reference to the CDOT "Pre-Qual List". A Prime Contractor requiring additional information regarding bidding can go to <https://www.codot.gov/business/bidding>.

1.4 The Qualified Manufacturers List (QML) is used for suppliers of Steel Reinforcing Bars & Steel Dowel Bars, Epoxy Coaters for Reinforcing Steel, and Precast Concrete Structures. These products are required to be selected off the QML. All relevant details for the proper submittal of specified Standard Manufactured Materials and Fabricated Structural Materials are found in CDOT's Field Materials Manual under CP 11, Quality Management Plans for the Qualified Manufacturers List or the Approved Products List.

2. PROVIDE NOTIFICATION OF MATERIALS SOURCES AND SUPPLIERS

2.1 In accordance with Subsection 106.01 of the Standard Specifications: The Contractor shall submit a formal list of material sources and suppliers to the Engineer at least two weeks prior to delivery; however, it is preferable that the list be presented at the Pre-Construction Meeting. The Department will sample and test materials proposed by the Contractor to be utilized for Items 203, 206, and 304. If the Department test results indicate the material is not in conformance with the project specifications, the Contractor is directed to Subsection 106.02 regarding Contractor Source materials and additional testing requirements.

2.2 The list shall include: item to be supplied, quantity, a reference to the level of acceptance required by CDOT (per Section 7, Designated Products and Assemblies), company's name and address manufacturing the material or product,

and contact person (if the material is to be pre-inspected or if a problem exists with the material delivered). The submitted list shall indicate, immediately after the item being referenced, the applicable acceptance level required:

- (A) Pre-Inspection (PI)
- (B) Certified Test Report (CTR)
- (C) Certificate of Compliance (COC)
- (D) Pre-Approved (per APL &/or QML)

2.3 All required product or material documentation shall be provided at the point and time of delivery to the construction project. Failure to provide the required documents, such as CTRs and COCs, may result in rejection of the materials. Failure to utilize the QML or APL may result in rejection of the materials.

3. INNOVATIVE CONTRACTING (DESIGN / BUILD PROJECTS, CM/GC PROJECTS, ETC.) - MATERIALS DOCUMENTATION RECORD, CDOT FORM #250

3.1 Two weeks before construction of any element of work the Contractor shall furnish the Engineer a schedule of items, approximate quantities to be incorporated into the project, and a reference to the method of acceptance required by CDOT (per Section 7, Designated Products and Assemblies). This information is to include the item of work with its placement location and dates. The Contractor shall immediately notify the Engineer, in writing, if the items of work or quantities are revised.

3.2 At the completion of the project, the Contractor shall furnish the Engineer with a completed CDOT Form #250 - Materials Documentation Record listing items utilized to construct the project and the approximate quantity of each item.

4. BUY AMERICA REQUIREMENTS

4.1 In accordance with Subsection 106.11 of the Standard Specifications as referenced in 23 CFR Part 635.410:

4.1.A Regulations require the use of domestic steel and iron in Federally funded construction projects. Buy America applies to construction components which are "predominately steel products," defined by CDOT as products which are manufactured with at least 80% steel or iron content when delivered to the job site for

installation. (See "C" below for examples.) CDOT provides waivers for manufactured products and products that are not predominately steel or iron. (See "D" below for examples.) Buy American strictly limits, but does not eliminate, the amount of foreign steel. (See "E" for minimum use & waiver information.)

4.1.B All manufacturing processes are defined as "processes required to change the raw ore or scrap metal into the finished, in-place steel or iron product". Manufacturing begins with the initial melting and mixing, and continues through the coating stage. Any process which modifies the chemical content, the physical size or shape, or the final finish is considered a manufacturing process.

4.1.C Examples of products that are subject to Buy America requirements include, but are not limited to, the following:

- steel or iron products used in pavements, bridges, tunnels or other structures, which include, but are not limited to, the following: fabricated structural steel, reinforcing steel, piling, high strength bolts, anchor bolts, dowel bars, permanently incorporated sheet piling, bridge bearings, cable wire/strand, pre-stressing / post-tensioning wire, motor/machinery brakes and other equipment for moveable structures;
- guardrail, guardrail posts, end sections, terminals, cable guardrail;
- steel fencing material, fence posts;
- steel or iron pipe, conduit, grates, manhole covers, risers;
- mast arms, poles, standards, trusses, or supporting structural members for signs, luminaires, or traffic control systems; and
- steel or iron components of precast concrete products, such as reinforcing steel, wire mesh and pre-stressing or post-tensioning strands or cables.

4.1.D Examples of products which are exempt from Buy America requirements include, but are not limited to, the following:

- products made of material other than steel or iron (aluminum, copper, brass, nickel, etc.);
- cabinets, covers, shelves;
- clamps, fittings, sleeves;
- washers, bolts, nuts, screws;
- tie wire, spacers;
- chairs;
- lifting hooks;
- faucets; and

- door hinges.

4.1.E Buy America will not prevent a minimal use of foreign steel or iron provided the total project delivery cost of all such steel and iron which includes the cost of delivering the steel and iron to the project, does not exceed one-tenth of one percent of the total contract cost or \$2,500, whichever is greater. With prior concurrence from FHWA Headquarters, the FHWA Division Administrator may grant a waiver of the Buy America requirements for specific projects. When domestic steel products are available, meeting the contractor's schedule should not be the basis for requesting a Buy America waiver.

4.1.F The Contractor shall maintain the certifications on file at the project that every process, including the application of a coating, performed on steel or iron products either has or has not been carried out in the United States of America. These certifications shall create a chain of custody, and the lack of these certifications will be justification for rejection of the steel or iron product.

4.1.G Prior to the permanent incorporation into the project of any steel or iron product (domestic or foreign), the Contractor shall certify in writing to the Project Engineer that the delivered quantity of each material meets the contract Buy America requirements; that the original Buy America Certification from the Supplier is on file in the Contractor's project office; and the steel or iron products are in compliance with the plans and specifications for this project.

The Contractor shall maintain a document summarizing the date and quantity of the material utilizing CDOT's Item Number(s) and Item Description(s) delivered to the project, along with the quantity of material installed during the month. The Contractor shall provide documentation of the project delivered cost of all foreign steel or iron permanently incorporated into the project, if any. This summary shall be delivered to the Project Engineer on a monthly basis as established per the revision of Section 106.11 of the Standard Specifications for Road and Bridge Construction. A monthly summary shall be required even if no steel or iron products are incorporated into the project during the month. [Examples of these requirements are shown on pages 13 thru 15 of this chapter.]

NOTE 1: Section 106.11 of the CDOT Construction Manual contains specific information on Buy America Requirements.

5. GLASS BEADS for PAVEMENT MARKING

5.1 The material shall meet the requirements of Standard Specifications Subsection 106.11, Section 627, and Subsection 713.08.

6. QUALITY MANAGEMENT PLANS FOR THE QUALIFIED MANUFACTURERS LIST OR THE APPROVED PRODUCTS LIST

6.1 CP 11 specifies requirements and procedures for a certification system that shall be applicable to all referenced manufacturers, as well as suppliers and contractors within certain industries. Certifying a Manufacturer's Quality Management Plan is not an automatic acceptance of any particular product, but an acknowledgement that the Manufacturer has taken steps to ensure that their quality controls meet the applicable Industry standards. Manufacturers whose Quality Management Plans are acceptable will be placed on the Qualified Manufacturers List (QML). Only Manufacturers listed on the QML will be eligible to provide the referenced products to a CDOT project.

6.2 The following Standard Manufactured Materials as referenced in CP 11 require an annual submission of a Quality Management Plan along with a sample for evaluation.

- Part I, Standard Manufactured Materials
 - Sub-Part 1. Asphalt Binder
 - Sub-Part 2. Asphalt Emulsion
 - Sub-Part 3. Hydraulic Cement
 - Sub-Part 4. Fly Ash
 - Sub-Part 5. Hydrated Lime

These products are located on the APL.

6.3 The following Fabricated Structural Materials as referenced in CP 11 require an annual submission of a Quality Management Plan.

- Part II, Fabricated Structural Materials
 - Sub-Part 1. Steel Reinforcing Bars & Steel Dowel Bars
 - Sub-Part 2. Epoxy Coaters of Reinforcing Steel
 - Sub-Part 3. Precast Conc. Structures

The QML is located within CDOT's Approved Products List (APL) web site, at www.codot.gov/business/APL. A Notice to Manufacturers is located within the same web site that references specific evaluation protocols including AASHTO's National Transportation Product Evaluation Program (NTPEP).

6.4 The respective QML web site pages are updated regularly. All pages will have at least

one revision referencing acceptability for the new calendar year.

7. DESIGNATED PRODUCTS AND ASSEMBLIES

7.1 The majority of materials submitted for inclusion on CDOT projects will fall within one of four methods of product acceptance for their sampling and testing. CDOT always retains the right through its Quality Assurance (QA) Program to obtain samples for additional testing and require supplemental documentation.

7.2 If the material or product is not referenced within the four methods of product acceptance then the materials or products must be fabricated or supplied in accordance with the requirements of the applicable Colorado Department of Transportation specifications, plans, and standards. An example of processed materials not found in the following four methods are Aggregate Base Course (ABC), Hot Mix Asphalt (HMA), and Concrete (PCCP). An example of a manufactured product treated uniquely is the Dynamic Message Signs (DMS) which are competitively bid on projects or through state awards.

7.3.a. PRE-INSPECTION (PI):

Pre-Inspection is when representatives from the Colorado Department of Transportation visit a manufacturer's facility to perform an initial review of the company's quality control plan and employee certifications, as well as subsequent inspection visitations during the manufacturing of the product. Inspection arrangements shall be made by contacting the CDOT Staff Bridge Fabrication and Construction Inspectors at (303) 757-9339 a minimum of 10 days prior to the beginning of fabrication. Failure to give notification will result in delays to the project and/or rejection of materials or products.

NOTE 2: Bearing Devices and Expansion Devices are inspected randomly at the discretion of the Staff Bridge Fabrication Inspectors.

Products needing Pre-Inspection:

- Bearing Devices (Type III) - Bridge^A
- Expansion Device, Modular - Bridge^A (0-6", through, 0-24")
- Prestressed Concrete Units - Bridge^A
- Structural Steel - Bridge^A

CDOT Form #193 is to be provided with the above referenced products.

7.3.b. CERTIFIED TEST REPORT (CTR):

The Certified Test Report method of acceptance is when a manufacturer is required to submit the actual test results performed on the material being provided. A CTR shall contain the actual results of tests for the chemical analysis, heat treatment, and/or mechanical properties per the drawing and/or specification. The contract will designate products and assemblies that can be incorporated in the work, if accompanied by Certified Test Reports. The word preceding the "Test Report" may vary between different industries, such as Certified, Mill, Metallurgical, Laboratory; however, they are all considered equivalent.

In accordance with Subsection 106.13 of the Standard Specifications and the requirements of this document, each CTR shall include:

- 1) Department's project number,
- 2) Manufacturer's name,
- 3) Address of manufacturing facility,
- 4) Laboratory name & address,
- 5) Name of product or assembly,
- 6) Complete description of the material,
- 7) Model, catalog, stock no. (if applicable),
- 8) Lot, heat, or batch number identifying the material delivered,
- 9) Date(s) of the laboratory testing,
- 10) All test results that are required so as to verify that the material furnished conforms to all applicable Department specifications. Test results shall be from tests conducted on samples taken from the same lot, heat, or batch.
- 11) The following certification, signed by a person having legal authority to act for the Contractor: [Example on page 6.]

The Certified Test Report shall be a legible copy or an original document and shall include the Contractor's original signature. The signature (including corporate title) on the Certified Test Report, under penalty of perjury, shall be of a person having legal authority to act for the manufacturer or the independent testing laboratory. It shall state that the test results show that the product or assembly to be incorporated into the project has been sampled and passed all specified tests in conformity to the plans and specifications for this project. One legible copy or original document of the fully signed Certified Test Report shall be furnished to the Engineer prior to installation of the material. Failure to comply may result in delays to the project and/or rejection of the materials.

Each product or assembly delivered to the project must contain the lot, heat, or batch number identical to that on the accompanying Certified Test Report. Products or assemblies furnished on the basis of Certified Test Reports may be sampled and tested by the Department and if determined that the material does not meet the applicable specifications, the material will be rejected or accepted according to Subsection 105.03.

[An example of what is required on a CTR is on page 16 of this chapter.]

Products requiring Certified Test Report
(below is an incomplete list):

Bearing Devices (Type III) - Bridge^A
 Bridge Deck Forms, Permanent Steel^A
 Cribbing, Steel
 Geogrid (or COC, per project specs)
 Glass Beads (for pavement marking)
 Mechanical Fasteners (Field)^A
 Overhead Sign Structures^A
 Pedestrian & Bikeway Railing
 Quicklime
 Soil Conditioner
 Structural Plate Structures
 Top Soil
 Traffic Signal Structures^A
 Water, Non-Potable
 Welded Wire Reinforcement

7.3.c. CERTIFICATE OF COMPLIANCE (COC):

The Certificate of Compliance method of acceptance is when a manufacturer is required to submit a document certifying that the material being provided meets all required Department specifications. A COC shall reference the required specifications for the chemical analysis, heat treatment, and/or mechanical properties per the drawing and/or specification, but not the actual test results. The contract will designate products and assemblies that can be incorporated in the work, if accompanied by Certificates of Compliance.

In accordance with Subsection 106.12 of the Standard Specifications and the requirements of this document, the certificate shall include:

- 1) Department's project number,
- 2) Manufacturer's name,
- 3) Address of manufacturing facility,
- 4) Laboratory name & address,
- 5) Name of product or assembly,
- 6) Complete description of the material,
- 7) Model, catalog, stock no. (if applicable),
- 8) Lot, heat, or batch number identifying the material delivered,

- 9) Date(s) of the laboratory testing,
- 10) Listing of all applicable specifications required by the Department for this particular product or assembly. Certificates shall reference the actual tests conducted on samples taken from the same lot, heat, or batch, and shall include a statement that the product or assembly to be incorporated into the project was fabricated in accordance with and meets the applicable specifications.
- 11) The following certification, signed by a person having legal authority to act for the Contractor: [Example on page 6.]

The original Certificate of Compliance shall include the Contractor's original signature. The original signature (including corporate title) on the Certificate of Compliance, under penalty of perjury, shall be of a person having legal authority to act for the manufacturer. It shall state that the product or assembly to be incorporated into the project has been sampled and passed all specified tests in conformity to the plans and specifications for this project. One legible copy of the fully signed Certificate of Compliance shall be furnished to the Engineer prior to installation of material. The original shall be provided to the Engineer before payment for the represented item will be made.

Each product or assembly delivered to the project must contain the lot, heat, or batch number identical to that on the accompanying Certificate of Compliance. Products or assemblies furnished on the basis of Certificates of Compliance may be sampled and tested by the Department and if determined that the material does not meet the applicable specifications, the material will be rejected or accepted according to Subsection 105.03.

[An example of what is required on a COC is on page 17 of this chapter.]

NOTE 3: If the Plans do not specifically reference a Certified Test Report (Mill Test Report) and the product category is not listed on the Approved Products List within the Pre-Approved level of acceptance, then a COC will be required.

Products requiring Certificate of Compliance (below is an incomplete list):

AEP (Asphalt Emulsion Prime)
Aggregate Bag (for the bag, CTR for agg.)
Bearing Devices (Type I, II ^{A B})
Bridge Rail, Steel ^A
Catch Basin Insert

Cattle Guard Boxes, Pre-Cast
Concrete Box Culverts, Precast
Dampproofing, Asphalt
Delineator Posts, Steel
Ditch Control (Erosion Log & Silt Dike)
Dust Palliative, Asphaltic or Magnesium Chloride
Erosion Bales ^D
Expansion Joint Material, Preform. Filler
Fence (Wires & Posts)
Fertilizer
Flumes (all types) Gabions and Slope
Mattress
Gaskets
Geogrid (for Erosion Control)
Glass Beads (for PMM)
Guard Rail - End Anchors
Guard Rail Metal ^A
Guard Rail Posts - Metal ^A
Guard Rail - Precast
Guard Rail Posts - Timber Blocks and Posts ^A
Hay ^D
Headgates
Hydraulic Soil Stabilizers
Inlets, Grates and Frames (Prefab)
Interior Insulation
Irrigation Systems
Lighting, all items
Light Standards, High Mast
Light Standards, Metal
Luminaires (Inclusive)
Manholes, Rings and Covers (Prefab)
MSE Wall - Elements ^{A,C}
Mulch (Hydraulic or Dry Applied)
Mulch Tackifier
Pedestrian Bridge ^A
Perimeter Control (Silt Fence)
Piling ^A
Pipes - all material compositions
Rest Area Materials (construction of)
Retaining Wall Blocks
Seeding (Native), Seed ^C
Sign Panels
Sprinkler System(s)
Steel Chairs
Steel Sign Posts
Steel Sheet Piling ^A
Storm Drain Inlet Protection
Straw ^D
Structural Glazed Tile and Ceramic Tile
Structural Plate Structures ^A
Structural Steel Galvanized ^A
Treated Timber
Vegetation (Sod & Plants)
Water, Potable
Water Control Devices
Water Lines

Welded Wire Mesh

NOTE 4:

- A Mill Test Report shall be included.
- B Certified Test Report(s) on components must accompany the material or product.
- C Certified Test Report shall be included.
- D Contractor may obtain a current list of Weed Free Forage Crop Producers by contacting the Colorado Department of Agriculture at (303) 239-4149.

Example of stamp or affixed sticker to be placed on Certified Test Reports (CTRs), per Subsection 7.3 B (11).

I hereby certify under penalty of perjury that the material listed in this Certified Test Report represents _____ (quantity and units)	
of pay item _____	

(pay item # and description) that will be installed in conformance with the plans and specifications on Project Number _____ .	
_____	_____
Contractor Rep. Signature	Date

Example of stamp or affixed sticker to be placed on Certificates of Compliance (COCs), per Subsection 7.3 C (11).

I hereby certify under penalty of perjury that the material listed in this Certificate of Compliance represents _____ (quantity and units)	
of pay item _____	

(pay item # and description) that will be installed in conformance with the plans and specifications on Project Number _____ .	
_____	_____
Contractor Rep. Signature	Date

7.3.d. PRE-APPROVED (APL):

The Pre-Approved method of acceptance is when a manufacturer is required to submit all relevant documentation on their product in advance of any specific project. A primary requirement to be considered for the Approved Products List (APL) is that the material retains a very high level of uniformity and consistency in its production quality (i.e. not project specific).

The submittal of Product literature /Tech Data Sheet (TDS), Certificates of Compliance, Certified Test Reports, Materials Safety Data Sheets (MSDS), etc., as well as product samples for specific categories combine all previous methods of acceptance into one. A Manufacturer whose product is not currently on the APL should read and follow the instructions within the Notice to Manufacturers on the APL web site at www.codot.gov/business/APL .

Product evaluation can take a minimum of four months to in excess of a year for some product categories. If CDOT specifications need to be altered or created for a product's acceptance then it could take even longer.

In accordance with CDOT's Procedural Directive 1401.1, a manufacturer's product is evaluated within CDOT to determine its acceptability on CDOT construction projects, as defined by CDOT specifications, plans and standards. For additional information on the APL or the web site contact the Product Evaluation Coordinator within the Staff Materials & Geotechnical Branch at 303-398-6566.

Locate products on the web site through *APL Search*, and then use the referenced Category, the Manufacturer's name, or the Product name. A category search requires that the drop-down menus be used.

APL User Guidance

1. If three or more products are listed for any applicable category then one of these products shall be selected. If the category is unpopulated a COC will be required for the product actually used. If the category is under-populated a COC will be required for the product actually used if not from the APL. CDOT's Subject Matter Expert (SME) for the applicable category shall be contacted for assistance. A CTR may be requested if the Project Engineer deems it appropriate. Contact the CDOT Product Evaluation Coordinator at 303-398-6566 with any questions.

2. Products that are evaluated on a batch or lot basis and subsequently posted on the APL web site will not be posted indefinitely. They expire two years after their CTR date or they will be removed sooner if informed that the batch or lot is depleted. Specifically this refers to (1) single component, hot-applied, elastomeric membranes for bridge decks, (2) hot poured, joint/crack sealant, and (3) asphalt plug joints.

3. Asphalt Binder and Asphalt Emulsions: Approved asphalt binders and emulsions are valid for the calendar year in which they were tested and approved, as per CP 11. The year is incorporated into the product name. On February 1st of each calendar year all products from two previous years will be automatically removed.

4. Environmental Erosion Control and Sediment / Pollution Control: All questions regarding this category's materials, both the current specifications and the products, should be directed to the CDOT Staff Environmental Branch SME.

5. Traffic Control Pavement Marking Material Sub-Category: All questions regarding pavement marking materials, both the current specifications and the products, should be directed the CDOT Staff Traffic Branch SME.

6. Geosynthetics and Geotextiles: Materials Bulletin (2008 Number 1) dated January 25, 2008 is posted at: <http://www.codot.gov/Business/DesignSupport/Materials%20Bulletins/Materials%20Bulletins.htm>

This Materials Bulletin clarifies the terminology

and application of geosynthetics as specified in the Standard Specifications and the Standard Special Provision (SSP), *Revision of Sections 208, 420, 605, and 712 – Geosynthetics and Geotextiles*. For New York State web site navigation refer to (NYDOT APL Instructions) at www.dot.ny.gov/index?nd=nysdot . (See Item 420 on the OA Schedule.)

7. Concrete Mix Designs:

The APL website contains a folder listing concrete mix designs that have been pre-approved. When a concrete mix is placed on the APL, it meets the most current CDOT Standard Specifications; however, it may not meet a CDOT project's Special Provisions. CP 62 is the procedure for approving all concrete mixes for use on a CDOT project. (see Chapter 600)

8. Warm Mix Asphalt (WMA) Mixes:

The APL website contains a folder listing approved WMA technologies and a folder listing approved contractors for specific WMA technologies that have been pre-approved for use on CDOT Projects. Use of a WMA mix on a Project shall be approved by the Project Engineer with the concurrence of the Region Materials Engineer.

9. Contractors are required to submit a document entitled Contractor's APL-QML Verification along with a copy of the Form #595 to the project engineer documenting the selection of the CDOT APL products and/or QML facility that they wish to include for project incorporation. (Example on Page 18.)

10. APL Quality Assurance Program:

Upon selecting the sub-category or base-category the Product ID (PID), Product Name, Manufacturer, and Comments will be displayed.

(a) By clicking on the PID / Form #595 the Pre-Approved Product Evaluation Request & Summary will be displayed. This will provide the customer with both a mini product data sheet and the information necessary for additional product analysis for specific utilization.

(b) If a product fails to perform within minimum quality expectations contact the CDOT Product Evaluation Coordinator immediately via e-mail as listed in the APL web site.

DISCLAIMER: The Colorado Department of Transportation (CDOT) is not obligated to any manufacturer to use any of their products listed in the Approved Products List (APL). The APL simply documents that the listed products have been reviewed, tested, and evaluated against CDOT standards, and were found to be acceptable to be used in CDOT projects. Acceptance is based on product quality; however, price or availability may be the determining factor by a contractor or sub-contractor on the CDOT project.

The product shall be removed from the APL if Product Performance comments indicate that field performance is unacceptable to CDOT quality standards or if the product varies from the data as originally submitted. Additional disclaimer information can be found within the APL web site.

<u>APL Category</u>	<u>APL Sub-Category</u>	<u>APL Base Category</u>	<u>Material Code</u>
Adhesive:	Anchoring, Lateral:	Acrylic	712.10.02.00
		Cementitious	712.10.02.00
		Epoxy	712.10.02.00
	Anchoring, Overhead: Bonding:	Polyester	712.10.02.00
		N/A	712.10.02.00
		Epoxy	712.10.01.00
Asphalt:	Asphalt Release Agent:	Truck Bed Only	401.09.01.00
	Binder:	Truck & Equipment	401.09.01.00
		PG 58-28	702.01.01.01
		PG 58-34	702.01.01.02
		PG 64-22	702.01.01.03
		PG 64-28	702.01.01.04
		PG 70-28	702.01.01.05
	Emulsion:	PG 76-28	702.01.01.06
		CSS-1	702.03.18.00
		CSS-1h	702.03.19.00
		CRS-2	702.03.15.00
		CRS-2P	702.03.21.00
		CRS-2R	702.03.23.00
		CQS-1h	702.03.20.00
		HFMS-2	702.03.08.00
		HFMS-2s	702.03.10.00
		HFMS-2P	702.03.25.00
		HFMS-2sP	702.03.26.00
		HFMS-2h	702.03.09.00
		HFRS-2P	702.03.24.00
		SS-1	702.03.11.00
	SS-1h	702.03.12.00	
	ARA-1P	702.04.02.00	
Hydrated Lime:	N/A	712.03.01.00	
Roadway Patching:	Pre-Mixed [Bagged]	401.02.01.00	
Bridge Structures:	Geocomposite Drain:	N/A	712.08.01.01
	Thin Bonded Overlay:	Epoxy	519.01.00.00
		Non-Epoxy	519.01.00.00
Structural Wrapping Repair	N/A	601.09.02.00	
Concrete:	Admixture:	Air Entraining	711.02.01.00
		Water-Reducing	711.02.01.00
		Retarding	711.02.01.00
		Accelerating	711.02.01.00
		Water-Reducing & Retarding	711.02.01.00
		Water-Reducing & Accelerating	711.02.01.00
		Water-Reducing, High Range	711.02.01.00
		Water-Reducing, HR & Retard.	711.02.01.00

<u>APL Category</u>	<u>APL Sub-Category</u>	<u>APL Base Category</u>	<u>Material Code</u>	
Concrete	Admixture	Extended Set-Control	711.02.01.00	
		Specific Performance	711.02.01.00	
		(Concrete) Corrosion Inhibitor	711.02.01.00	
		Pigments, Integrally Colored	711.02.01.00	
		Miscellaneous	711.02.01.00	
	Curing Compound:	Type 1 [Clear, Wax Based]	711.01.01.00	
		Type 1 [Clear, Resin Based]	711.01.01.00	
		Type 2 [White Pigmented, Wax Based]	711.01.01.00	
		Type 2 [White Pigmented, Resin Based]	711.01.01.00	
		Cement:	Portland Cement, ASTM C 150	701.01.01.00
	Blended Cement, ASTM C 595		701.01.02.00	
	Hydraulic Cement, ASTM C 1157		701.01.03.00	
	Pozzolan:	Fly Ash, Class C	701.02.01.00	
		Fly Ash, Class F	701.02.02.00	
		High Reactivity	701.02.04.00	
		Silica Fume	701.03.01.00	
		Concrete:	Fiber:	Macro Fiber
	Micro Fiber			709.04.02.00
	Grout:		General Purpose [Non-Shrink]	601.02.14.00
			Post-Tensioned Cable	618.02.01.00
	Repair/Patching:		Rapid Set, Horizontal	601.09.01.00
			Rapid Set, Vertical & Overhead	601.09.01.00
			Bonding Agent	601.09.01.00
Drainage:	Culvert Pipe:	Culvert Lining [Repair]	707.12.01.00	
		Open-Cut/Direct-Bury	712.13.02.00	
	Manholes & Inlets:	Manhole Riser	604.04.01.00	
		Trench Drain	712.14.01.00	
		Plastic Drains	712.14.01.00	
Environmental:	Sound Wall:	Absorptive	607.02.02.00	
		Reflective	607.02.02.00	
Erosion Control:	Soil Retention Rolled:	SRB [Biodegradable Class 1]	216.02.02.00	
		SRB [Photodegradable Class 1]	216.02.02.00	
		SRB [Biodegradable Class 2]	216.02.02.00	
		SRB [Photodegradable Class 2]	216.02.02.00	
Erosion Control:	Soil Retention Rolled:	TRM [Class1]	216.02.03.00	
		TRM [Class 2]	216.02.03.00	
		TRM [Class 3]	216.02.03.00	
		TRM [Class 4 / woven]	216.02.03.00	
Erosion Control:	Ditch Control:	Silt Berm	208.02.02.00	
		Sediment/Pollution Ctrl: Construction Inlet Protect.:	Storm Drain Inlet Protect. (Type 1)	208.02.08.01
Storm Drain Inlet Protect. (Type 2)	208.02.08.01			
Storm Drain Inlet Protect. (Type 3)	208.02.08.01			
Sediment/Pollution Ctrl:	Concrete Washout Structure:	Pre-Fabricated [Above Ground]	208.02.14.00	
Sediment/Pollution Ctrl:	Vehicle Tracking Control:	Pre-Fabricated	208.02.15.01	

<u>APL Category</u>	<u>APL Sub-Category</u>	<u>APL Base Category</u>	<u>Material Code</u>
Maintenance	Deicing, Liquid	Magnesium Chloride (Cat. 1)	712.04.01.00
Maintenance	Deicing, Granular	Brining Salt, Dry, Std (Cat. 8A-B)	712.04.02.00
		Road Salt, Dry, Std (Cat. 8A-R)	712.04.02.00
		Wet Salt, Std (Cat. 8B)	712.04.02.00
		Brining Salt, Dry, Fine (Cat. 8C)	712.04.02.00
		Road Salt, Dry, Fine (Cat. 8C-R)	712.04.02.00
Maintenance	Inhibitor / Enhancer	Corrosion Inhib, NaCl (Cat. A-1)	712.04.02.01
		Corrosion Inhib, NaCl (Cat. A-3)	712.04.02.01
Maintenance	Alternate Traction Device	Textile Traction Device	

Paint / Coating:	Anti-Graffiti:	N/A	708.02.01.00
	Concrete Corrosion Inhibitor:	N/A	708.08.01.00
	Epoxy Coating:	N/A	708.03.03.00
	Structural Concrete Coating:	N/A	708.08.01.00
	Structural Steel Paint:	N/A	708.03.02.00
	Wire Coating:	N/A	

Pedestrian Safety:	ADA Truncated Dome:	Embedded	608.02.03.00
		Retrofit	608.02.03.00
	Joint System	N/A	705.01.03.00

Right-of-Way Structure:	Mailbox Support System:	N/A	210.13.01.00
	Utility Enclosure:	N/A	604.04.02.00
	Fence, Non-Standard Coating	N/A	710.03.01.00
	Pole Base Hardware:	N/A	713.05.01.00

Roadway Safety:	Cable Barrier:	NCHRP 350 TL-3	606.02.06.00
		NCHRP 350 TL-4	606.02.06.00
	Guardrail W-Beam:	Guardrail End Treatment	606.02.03.00
		Guardrail End Treat., Spec. App.	606.02.03.00
		Guardrail Synthetic Blockout	606.02.04.00
		Crash Cushion:	Sand Barrel Array
		Guardrail Median Terminal	606.02.02.00
		Barrier End Treatment (Terminal)	606.02.02.00
		Impact Attenuator, Std, Perm.	614.07.02.00
		Impact Attenuator, Wide, Perm.	614.07.02.00
		Impact Atten., Lo-Maint, Perm.	614.07.02.00
		Impact Atten., Spec-App, Perm.	614.07.02.00
	Roadway Safety:	Railing	Pedestrian & Bicycle
Vehicle			606.02.05.00

Sealant [Joint & Crack]:	Asphaltic Plug Joint:	N/A	518.03.01.00
		Hot Poured, Joint/Crack:	ASTM D 6690, Type II
		ASTM D 6690, Type IV	702.06.01.00
		ASTM D 5078	702.06.02.00
	Mastic:	Under Development	702.06.03.00

Sealant [Joint & Crack]:	Silicone, Joint:	Non-Sag	705.01.01.00
		Self-Leveling	705.01.01.00
	Pre-Formed Joint Filler:	N/A	705.01.02.00
	Loop Detector Slot:	One Component	705.01.01.00
		Two Component	705.01.01.00

Soil / Geotechnical:	Stabilization:	Chemical, Liquid	308.03.02.01
	Void Elimination:	Polyurethane Foam, Hi Density	308.03.02.01

<u>APL Category</u>	<u>APL Sub-Category</u>	<u>APL Base Category</u>	<u>Material Code</u>			
Traffic Control:	Portable Changeable Message:	Trailer Mount	630.03.01.00			
		Vehicle Mount	630.03.01.00			
	Arrow Board:	Type A	630.03.01.00			
		Type B	630.03.01.00			
		Type C	630.03.01.00			
		Type D	630.03.01.00			
	Speed Notification:	Radar/Message Trailer	630.03.01.00			
		Speed Display Trailer	630.03.01.00			
		Speed Display Device	630.03.01.00			
	Traffic Control Enhancement:	AFAD	630.04.01.00			
		Flashing Beacon	614.06.01.00			
		Warning Light	630.08.02.00			
		Raised Island, Temporary	630.08.02.00			
		Rumble Strip, Temporary	630.08.02.00			
		Glare Screen	630.08.01.00			
	Channelizing Device:	Cone	630.05.01.00			
		Tubular Marker	630.05.02.00			
		Vertical Panel	630.06.01.00			
		Drum	630.06.02.00			
		Barricade, Type 1	630.06.02.00			
		Barricade, Type 2	630.06.02.00			
		Barricade, Type 3	630.06.02.00			
		Channelizing Device:	Direction Indicator Barricade	630.02.02.00		
			Longitudinal Channelizing Device	630.06.04.00		
		Delineator:	Opposing Traffic Lane Divider	630.06.03.00		
	Flexible Post		612.02.02.00			
	Flexible, Multiple Hit Post		612.02.02.00			
	Reflective Element:	Guardrail Mount	612.02.02.00			
		Barrier (Solid Wall) Marker	612.02.04.00			
		Guardrail & Post Marker	612.02.04.00			
		Delineator Post Marker	612.02.04.00			
		Linear Reflector Strip	612.02.05.00			
	Post Anchoring:	Mechanical System	612.05.01.00			
		Polyurethane Foam, Backfill	614.02.03.00			
	Traffic Barrier, Temporary:	Barrier, Non-Concrete	630.07.01.00			
		Barrier Gate	630.07.01.00			
	Crash Cushion, Temporary:	Impact Attenuator, Temporary	630.08.04.00			
		Truck Mounted Attenuator (TMA)	630.08.03.00			
		Trailer Mounted Attenuator	630.08.03.00			
	Traffic Control:	Sign Stand:	N/A	630.02.01.00		
	Traffic Control:	Pave. Marking Material:	Preformed Plastic Tape, Type I, Perm.	713.13.01.00		
			Preformed Plastic Tape, Type II, Perm.	713.13.01.00		
			Preformed Plastic Tape, Type III Perm.	713.13.01.00		
			Thermoplastic, Hot Applied	713.12.01.00		
			Thermoplastic, Preformed, Preheat	713.14.01.00		
			Thermoplastic, Preformed, No-Preheat	713.14.01.00		
			Epoxy Paint, Standard	713.17.01.01		
			Epoxy Paint, Modified	713.17.01.02		
			Polyurea	713.17.02.00		
			Methyl Methacrylate	713.19.01.00		
			Recessed Pavement Marker	713.18.02.00		
			Raised Flexible Marker (Temp.)	713.18.01.00		
			Temp. / Construction, Tape	713.16.01.00		
			Temp. / Construction, Paint	713.16.02.00		
			Traffic Control:	Sign Sheeting:	ASTM D 4956, Type IV	713.04.01.00
					ASTM D 4956, Type V	713.04.01.00
					ASTM D 4956, Type VI	713.04.01.00

<u>APL Category</u>	<u>APL Sub-Category</u>	<u>APL Base Category</u>	<u>Material Code</u>
		ASTM D 4956, Type VI	713.04.01.00
		[Roll-up & Cone Collar]	713.04.01.00
		ASTM D 4956, Type VIII	713.04.01.00
		ASTM D 4956, Type VIII, Fluorescent	713.04.01.00
		ASTM D 4956, Type IX	713.04.01.00
		ASTM D 4956, Type IX, Fluorescent	713.04.01.00
		ASTM D 4956, Type XI	713.04.01.00
		ASTM D 4956, Type XI, Fluorescent	713.04.01.00
		Films / Miscellaneous	713.04.01.00

Waterproofing:	Concrete Sealer:	Alkyl-alkoxy Silane	515.03.01.00
		Non-Alkyl-alkoxy Silane	515.03.01.00
		Penetrating Epoxy	515.03.01.00
		Micro-Subsurface Repair	515.03.01.00
	Elastomeric Membrane:	Single Component, Hot Applied	705.09.01.00
		Non-Asphaltic	705.08.01.00



Kryptonite Construction Inc.

13369 W. Rocky Rd. Smallville, Colorado 91130

Phone 999-123-4567

Attn: Project Engineer

Date: July 10, 2016

Re: CDOT Contract ID: 53124

Re: CDOT Project No. CC 00-0000-00

Subject: Buy America Certification

Kryptonite Construction hereby certifies that the materials and quantities represented below, to be incorporated into the project, meet the contract Buy America requirements. We also certify that the Buy America paperwork and certifications required by Section 106.11 are on file at the project.

- 1.) 550 LF of 24" culvert pipe for bid item 603-01180

Respectfully,

Clark Kent
 Construction Manager
 Kryptonite Construction Inc.

<p><i>EXAMPLE</i> <u>Buy America Requirements</u> (Per requirements of Subsection 4.1) (Original Signatures Required, No Facsimiles Accepted)</p>

Note 1: The Buy America Certification is to always be received by the Project Engineer prior to the steel or iron being incorporated into the project.

Note 2: The delivery date and/or the incorporation date may be included in the letter.



Summary of Buy America Certifications Received for Installed Steel / Iron Products

CDOT Project No.: CC000-000-00

CDOT Contract ID: 53124

Summary for the Period Ending: October 2016

Item	Item Description	Quantity Delivered to Project	Unit	Delivered Cost*	Delivery Date	Installed Quantity	Unit	Installation Month	BUY AMERICA CERTIFICATION Date	BUY AMERICA CERTIFICATION Quantity
603-01180	24" culvert pipe	550	LF		11-Jul-16	300	LF	Aug-16	10-Jul-16	550 LF
603-01180	24" culvert pipe	550	LF			250	LF	Oct-16	10-Jul-16	550 LF
Total										

Prepared by: _____ Title: _____ Date: _____

* If there is any foreign steel or iron permanently incorporated into the project the Contractor shall provide documentation of the project delivered cost of that foreign steel or iron.

EXAMPLE

Suggested format for the reconciliation of the Buy America certification quantities with installed quantities. The Contractor shall submit this summary to the Project Engineer.

Subsection 4.1.G "The Contractor shall maintain a document summarizing the date and quantity of the material utilizing CDOT Item Number(s) and Item Description(s) delivered to the project, along with the quantity of material installed during the month."

CLARIFICATION: This Summary example indicates that the Period ended in October. The Buy America Certification date is from July 10th and the Delivery Date is from July 11th. This example document summarizes the quantity delivered along with the quantity installed.



Kryptonite Construction Inc.

13369 W. Rocky Rd. Smallville, Colorado 91130

Phone 999-123-4567

Attn: Project Engineer

Date: November 28, 2016

Re: CDOT Contract ID: 53124

Re: CDOT Project No. CC 00-0000-00

Subject: Buy America Exception for Foreign Steel

Kryptonite Construction Inc. hereby certifies that throughout the entirety of the above referenced project there was one acquisition of steel / iron from a non-American source. The Minor Exception documentation is on file at the project's Contractor's trailer as required by Section 106.11 of the contract.

- No Exception
- Minor Exceptions: Value less than 1/10 of 1% of the total contract cost or \$ 2,500.00 whichever is greater. Documentation is in our Project Files.

1.) 16 panels of ADA Truncated Domes which were imported from China were incorporated into the project. The total contract cost to date of imported steel or iron is \$1,831.66.

Respectfully,

Clark Kent
 Construction Manager
 Kryptonite Construction Inc.

EXAMPLE
Buy America Requirements
 (Per requirements of Subsection 4.1)
 (Original Signatures Required, No Facsimiles Accepted)

American Glass Bead Inc.

Desert Ray, Tx. 76660
 Phone: (254)562-2541
 Fax: (254)562-2542
www.agbi.com

CERTIFIED TEST REPORT

Colorado Department of Transportation (CDOT) project number: MTCE 03-022

Name of Product: AASHTO M 247 Type 1 Colorado Spec Glass Beads

*Product Code: AGBI- 0123

Product Batch Number: 021805

*Product date of manufacturing: April 25, 2017

*Quantity Shipped: 44000 Pounds

* Date of Shipment: TBA

Laboratory Information:

*AGBI Inc.: HWY 40 & FCR 145

*Testing Date: 2/18/05

* Samples Tested: Samples are from Batch # 021805

AASHTO Designation M 247

*AASHTO M 247 Type 1 Colorado Spec

Test Results: Gradation (ASTM Standard D 1214)

Sieve Designation	Specification for AASHTO M 247 Mass Percent Passing (Type 1)	Test Result
No. 20 (0.850 mm)	100	100
No. 30 (0.600 mm)	75-95	86.9
No. 40 (0.425 mm)	-	-
No. 50 (0.300 mm)	15-35	24.2
No. 80 (0.180 mm)	-	-
No. 100 (0.150 mm)	0-5	.7

AASHTO M 247 Type 1

Test Results: Other Properties

Element / Method	Specification for AASHTO M 247 Specification Limit	Test Result
Roundness/ASTM D 1155	70% min	71.4%
Crushing Resistance ASTM D 1213	Retained 0.425-mm (No. 40) sieve 133N (30 lbs.) min.	Passing
Refractive Index (Ref: TTB1325C Section 4.3.3)	1.50 min	1.52
Moisture Resistance	Non-Moisture absorption & Free flowing	Passing
Flotation	90% of all beads shall float in xylene	n/a

Certification of Material: The referenced material meets or complies with the AASHTO M 247 Type 1 Colorado Specification.

Billy Gibbons

18 May, 2017

 Billy Gibbons / Quality Control

 Date

EXAMPLE-CTR

[Per requirements of Section 7]
 (Original Signatures Required,
 Legible copy Accepted)

I hereby certify under penalty of perjury that the material listed in this Certified Test Report represents _____ (quantity and units) of pay item _____ (pay item # and description) that will be installed in conformance with the plans and specifications on Project No. _____.

 Contractor

 Date

North-By-Northwest, North-By-Northwest, Inc.
 9876 S. Eva-Marie Blvd.
 Grant, South Dakota 54321
 Phone 999-123-4567

Certificate of Compliance

Product Name: Universal Bridge Deck Expansion Joint
Model: .UBDEJ-101
Lot: 135-02

Description: Pre-formed Silicone gland, that can be bonded directly to an Elastomeric concrete joint interface with a single component silicone-locking adhesive.

Material Testing Specifications:

<u>Property</u>	<u>Test Method</u>	<u>Mean Value</u>
Durometer (Shore A)	ASTM D 2240	55
Tensile (psi)	ASTM D 412	650 psi
Elongation (%)	ASTM D 412	382 %
Tear (die B ppi)	ASTM D 624	88 ppi
Compression Set At 350°F 22 hrs.	ASTM D 395	30 %
Operating Temperature Range		-60° F to 450° F
Specific Gravity		1.51

State Specification Reference:

Colorado DOT Standard Specifications for Road and Bridge Construction, Section 412.13 (c). Project plans as required.

CDOT Project Number NH 0507-123

The above referenced tests were performed within our laboratory on May 10th 2017.
 All tests passed and the minimum required values were exceeded. Applicable laboratory test reports are available upon your request.

North-By-Northwest, Inc.

John Doe

John Doe
 Manager, Quality Assurance

Date: 12 May 2017

I hereby certify under penalty of perjury that the material listed in this Certificate of Compliance represents _____ (quantity and units) of pay item _____ (pay item # and description) that will be installed in conformance with plans and specification on Project Number _____.

 Contractor

 Date

EXAMPLE-COC
 [Per requirements of Section 7]
 (Original Signatures Required,
 Legible copy Accepted)



Kryptonite Construction Inc.

13369 W. Rocky Rd. Smallville, Colorado 91130

Phone 999-123-4567

CONTRACTOR'S APL - QML VERIFICATION

Date: _____

CDOT Contract ID _____

CDOT Project No.: _____

CDOT Project Location: _____

The following material was selected from the CDOT Approved Products List or the facility was selected from the CDOT Qualified Manufacturers List in accordance with the project plans, the 2011 Standard Specifications for Road and Bridge Construction, and the 2018 Field Materials Manual. Include CDOT Form #595 with this letter if selecting from the APL.

QML Part/Sub-Part (per CP 11): _____

APL Category: _____

APL Sub-Category: _____

APL Base Category: _____

APL Reference No.: _____

Product / Facility Name: _____

Manufacturer: _____

Date of Web Site Review & Selection: _____

Kryptonite Construction Inc.

Veronica Dee

Veronica Dee
Construction Manager

I hereby certify under penalty of perjury that the material listed in this Certificate of Compliance represents _____ (quantity and units) of pay item _____ (pay item # and description) that will be installed in conformance with plans and specification on Project Number _____.

Contractor

Date

EXAMPLE
(Per requirements of Subsection 7.3.d)
(Original Signatures Required, No Facsimiles Accepted)

APPENDIX D

CDOT Forms:

CDOT Form #17 – Contractor DBE Payment Certification

CDOT Form #205 B – Sublet Permit Application

CDOT Form #605 – Contractors Performance Capability Statement

CDOT Form #621 – Assignment of Antitrust Claims

**COLORADO DEPARTMENT OF TRANSPORTATION
CONTRACTORS PERFORMANCE CAPABILITY STATEMENT**

Project #

1. List names of partnerships or joint ventures none

2. List decreases in the contractors fiscal or workmanship qualifications compared to the last prequalification statement submitted to CDOT. (Attach additional sheets if necessary.)

a. Key personnel changes none

b. Key equipment changes none

c. Fiscal capability changes (legal actions, etc.) none

d. Other changes that may effect the contractors ability to perform work. none

I DECLARE UNDER PENALTY OF PERJURY IN THE SECOND DEGREE, AND ANY OTHER APPLICABLE STATE OR FEDERAL LAWS, THAT THE STATEMENTS MADE ON THIS DOCUMENT ARE TRUE AND CORRECT TO THE BEST OF MY KNOWLEDGE

Contractor's firm or company name	By	Date
	Title	
2nd Contractor's firm or company name (if joint venture)	By	Date
	Title	

**COLORADO DEPARTMENT OF TRANSPORTATION
ASSIGNMENT OF ANTITRUST CLAIMS**

PROJECT NO.

Contractor and Colorado Department of Transportation (CDOT) recognize that in actual economic practice antitrust violations ultimately impact on CDOT. Therefore, for good cause and as consideration for executing this contract and for receiving payments hereunder:

1. Contractor hereby irrevocably assigns to CDOT any and all claims it may now have or which may hereafter accrue to it under federal or state antitrust laws in connection with the particular project, goods or services purchased or acquired by CDOT pursuant to this contract.
2. Contractor hereby expressly agrees:
 - a. That, upon becoming aware that a third party has commenced a civil action asserting on Contractor's behalf an antitrust claim which has been assigned to CDOT hereunder, Contractor shall immediately advise in writing:
 - (1) Such third party that the antitrust claim has been assigned to CDOT, and
 - (2) CDOT that such civil action is pending and of the date on which, in accordance with subparagraph a. (1) above, Contractor notified such third party that the antitrust claim had been assigned to CDOT;
 - b. To take no action which will in any way diminish the value of the claims or rights assigned or dedicated to CDOT hereunder; and
 - c. Promptly to pay over to CDOT its proper share of any payment under an antitrust claim brought on Contractor's behalf by any third party and which claim has been assigned to CDOT hereunder.
3. Further, Contractor agrees that in the event it hires one or more subcontractors to perform any of its duties under the contract, Contractor shall require that each such subcontractor:
 - a. Irrevocably assign to CDOT (as a third party beneficiary) any and all claims that such subcontractor may have or which may thereafter accrue to the subcontractor under federal or state antitrust laws in connection with any goods or services provided by the subcontractor in carrying out the subcontractor's obligations to Contractor;
 - b. Upon becoming aware that a third party has commenced a civil action on the subcontractor's behalf asserting an antitrust claim which has been assigned to CDOT hereunder, shall immediately advise in writing:
 - (1) Such third party that the antitrust claim has been assigned to CDOT, and
 - (2) Contractor and CDOT that such civil action is pending and of the date on which, in accordance with subparagraph b. (1) above, the subcontractor notified such third party that the antitrust claim had been assigned to CDOT;
 - c. Take no action which will in any way diminish the value of the claims or rights assigned or dedicated to CDOT hereunder; and
 - d. Promptly pay over to CDOT its proper share of any payment under an antitrust claim brought on the subcontractor's behalf by any third party and which claim has been assigned or dedicated to CDOT pursuant hereto.

I, acting in my capacity as officer of a bidder (bidders if a joint venture) do agree to the above assignment of antitrust claims.

Contractor's firm or company name	By	Date
	Title	
2nd contractor's firm or company name. (if joint venture.)	By	Date
	Title	

Oversight / NHS

FHWA REGION VIII OVERSIGHT? NO YES

NATIONAL HIGHWAY SYSTEM? NO YES

DESCRIPTION OF PROJECT

CONSTRUCT MODERN STYLE MID-BLOCK CROSSINGS FOR HORIZON DRIVE. THIS IS A HAZARD ELIMINATION FUNDED PROJECT WHICH INCLUDES AGGREGATE BASE COURSE, CONCRETE WALK, CURB, GUTTER, CONCRETE MEDIAN COVER MATERIAL, PEDESTRIAN LIGHTING, AND RECTANGULAR RAPID FLASHING BEACONS.

A MANDATORY PRE-BID CONFERENCE WILL BE HELD ON JUNE 22, 2018 AT 10:00 AM AT THE MESA CONFERENCE ROOM LOCATED AT 606 SOUTH 9TH STREET (CDOT MAINTENANCE BUILDING), GRAND JUNCTION, COLORADO TO PRESENT A BRIEF OVERVIEW OF THE PROJECT AND TO ANSWER QUESTIONS FROM PROSPECTIVE BIDDERS.

TABULATION OF LENGTH & DESIGN DATA

STATION	ROADWAY	FEET	MILES
HORIZON DRIVE STA 64+00 TO STA 81+00		1700	0.32
TOTAL		1700	0.32
SUMMARY OF PROJECT LENGTH			
DESIGN DATA			
MINIMUM RADIUS OF CURVE		** 1 ft	HORIZON DRIVE
MAXIMUM GRADE		** 2.00%	
MINIMUM S.S.D. HORIZONTAL		NA	
MINIMUM S.S.D. VERTICAL		NA	
MAXIMUM DESIGN SPEED		35mph	
2015 DESIGN TRAFFIC		DHV = 915 ADT = 10166	
DHV TRUCKS %		2%	
CLEAR ZONE DISTANCE (TANGENT)		** NA	
CLEAR ZONE DISTANCE (for min radius)		NA	

* FOR INFORMATION ONLY ** Behind Face of Curb

DEPARTMENT OF TRANSPORTATION STATE OF COLORADO

HIGHWAY CONSTRUCTION BID PLANS OF PROPOSED

PROJECT NO. SHO M555-033

Grand Junction Horizon Drive Crosswalks

MESA COUNTY

CONSTRUCTION PROJECT CODE NO. 22497

SEC. 36, TOWNSHIP 1 NORTH, RANGE 1 WEST, UTE PRINCIPAL MERIDIAN

Related Projects:

P. E. UNDER PROJECT: SHO M555-033
Project Number: 22497
Project Code:

SHEET No. INDEX OF SHEETS

- 1 TITLE SHEET
- 2 CDOT STANDARD PLAN LIST
- 3 TYPICAL SECTION
- 4 GENERAL NOTES
- 5 SUMMARY OF APPROXIMATE QUANTITIES
- 6 PROJECT OVERVIEW
- 7 TABULATION OF REMOVALS
- 8-9 TABULATION OF NEW SURFACES
- 10 TABULATION OF PULL BOXES, CONDUIT, AND LIGHT STANDARD FOUNDATIONS
- 11 SURVEY TABULATION
- 12 SURVEY CONTROL PLAN
- 13-15 STAKING PLAN
- 16-18 REMOVAL PLAN
- 19-21 ROADWAY CROSSING PLAN
- 22-25 UTILITY PLAN
- 26-28 0.1 FOOT CONTOUR PLAN
- 29 TABULATION OF SIGNALS & FINAL SIGNING
- 30-32 SIGNAL AND SIGNING PLAN
- 33 TABULATION OF STRIPING
- 34-36 STRIPING PLAN
- 37-43 STORM WATER MANAGEMENT PLAN
- 44 TABULATION OF CONSTRUCTION TRAFFIC CONTROL DEVICES
- 45-55 LIGHTING PLAN

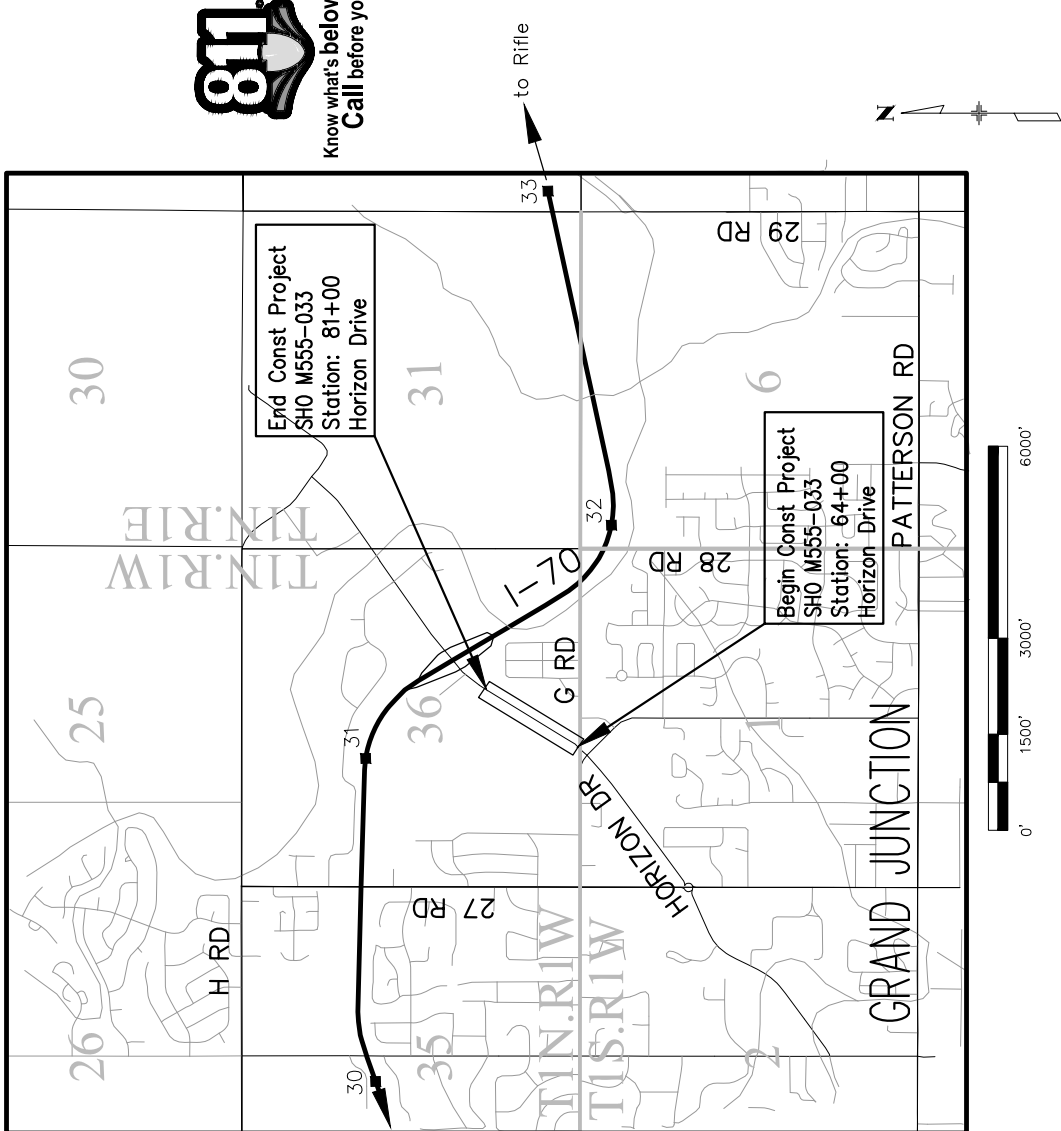

Know what's below.
Call before you dig.

Colorado Department of Transportation

Region 3

606 South 9th Street
Grand Junction, CO, 81501
Phone: 970-683-6351 FAX: 970-683-6369

SHY

Sheet Revisions	
Date:	Comments

CITY OF
Grand Junction
COLORADO

333 West Ave. Grand Junction, CO, 81501 Phone: 970-244-1554

As Constructed
No Revisions:
Revised:
Void:

Contract Information	
Contractor:	
Resident Engineer:	
Project Engineer:	
PROJECT STARTED: ---/---/---	ACCEPTED: ---/---/---
Comments:	

Project No./Code
SHO M555-033
22497
Sheet Number 1

PLAN NUMBER	NEW OR REVISED	M STANDARD TITLE	PAGE NUMBER	NEW OR REVISED	M STANDARD TITLE	PAGE NUMBER	PLAN NUMBER	NEW OR REVISED	S STANDARD TITLE	PAGE NUMBER
M-100-1		STANDARD SYMBOLS (3 SHEETS)	1-3	M-607-1	WIRE FENCES AND GATES (3 SHEETS)	100-102	S-612-1	<input type="checkbox"/>	DELINEATOR INSTALLATIONS (8 SHEETS)	(REVISED ON APRIL 12, 2018).151-157-
M-100-2		ACRONYMS AND ABBREVIATIONS (4 SHEETS)	4-7	M-607-2	CHAIN LINK FENCE (3 SHEETS)	103-105	S-614-1	<input checked="" type="checkbox"/>	GROUND SIGN PLACEMENT (2 SHEETS)	(REVISED ON DECEMBER 12, 2014).158-159-
M-203-1	<input type="checkbox"/>	APPROACH ROADS (REVISED ON JULY 08, 2013)	8	M-607-3	BARRIER FENCE	106	S-614-2	<input checked="" type="checkbox"/>	CLASS I SIGNS (REVISED ON JUNE 24, 2016)	160
M-203-2		DITCH TYPES	9	M-607-4	DEER FENCE, GATES, AND GAME RAMPS (5 SHEETS)	107-109-	S-614-3		CLASS II SIGNS	161
M-203-11		SUPERELEVATION CROWNED AND DIVIDED HIGHWAYS (3 SHEETS)	10-12	M-607-10	PICKET SNOW FENCE	110	S-614-4	<input type="checkbox"/>	CLASS III SIGNS (3 SHEETS)	(REVISED ON DECEMBER 17, 2014)162-164-
M-203-12		SUPERELEVATION STREETS (2 SHEETS)	13-14	M-607-15	ROAD CLOSURE GATE (9 SHEETS)	111-119	S-614-5	<input type="checkbox"/>	BREAK-AWAY SIGN SUPPORT DETAILS FOR GROUND SIGNS (2 SHEETS)	(REVISED ON FEBRUARY 8, 2017) .165-166-
M-206-1		EXCAVATION AND BACKFILL FOR STRUCTURES (2 SHEETS)	15-16	M-608-1	CURB RAMPS (10 SHEETS) (REVISED ON FEBRUARY 23, 2017)	120-125-	S-614-6	<input type="checkbox"/>	CONCRETE FOOTINGS AND SIGN ISLANDS FOR CLASS III SIGNS (2 SHEETS)	(REVISED ON SEPTEMBER 16, 2013)167-168-
M-206-2		EXCAVATION AND BACKFILL FOR BRIDGES (2 SHEETS)	17-18	M-609-1	CURBS, GUTTERS, AND SIDEWALKS (4 SHEETS)	126-129-	S-614-8	<input type="checkbox"/>	TUBULAR STEEL SIGN SUPPORT DETAILS (7 SHEETS)	169-173-
M-208-1	<input checked="" type="checkbox"/>	TEMPORARY EROSION CONTROL (11 SHEETS) (REVISED ON AUGUST 10, 2017)	19-30	M-611-1	CATTLE GUARD (2 SHEETS)	130-131	S-614-9	<input type="checkbox"/>	PEDESTRIAN PUSH BUTTON POST ASSEMBLY (REVISED ON MAY 24, 2016)	174-
M-210-1		MAILBOX SUPPORTS (2 SHEETS)	31-32	M-611-2	DEER GUARD (2 SHEETS) (NEW ON APRIL 30, 2015)	132-135	S-614-10	<input type="checkbox"/>	MARKER ASSEMBLY INSTALLATIONS	175
M-214-1		PLANTING DETAILS	33	M-613-1	ROADWAY LIGHTING (4 SHEETS)	136-138	S-614-11		MILEPOST SIGN DETAIL FOR HIGH SNOW AREAS	176
M-216-1	<input type="checkbox"/>	SOIL RETENTION COVERING (2 SHEETS) (NEW ON JULY 16, 2015)	34-36	M-614-1	RUMBLE STRIPS (3 SHEETS)	139-140	S-614-12	<input type="checkbox"/>	STRUCTURE NUMBER INSTALLATION (2 SHEETS)	(REVISED ON APRIL 30, 2016)177-
M-412-1	<input type="checkbox"/>	CONCRETE PAVEMENT JOINTS (5 SHEETS) (REVISED ON JANUARY 18, 2018)	39	M-614-2	SAND BARREL ARRAYS (2 SHEETS)	141	S-614-14		FLASHING BEACON AND SIGN INSTALLATIONS (3 SHEETS)	178-180
M-510-1		STRUCTURAL PLATE PIPE H-20 LOADING	40-41	M-615-1	EMBANKMENT PROTECTOR TYPE 3	142	S-614-20	<input type="checkbox"/>	TYPICAL POLE MOUNT SIGN INSTALLATIONS	181
M-601-1	<input type="checkbox"/>	SINGLE CONCRETE BOX CULVERT (2 SHEETS) (REVISED ON NOVEMBER 25, 2015)	42	M-615-2	EMBANKMENT PROTECTOR TYPE 5	143	S-614-21	<input type="checkbox"/>	CONCRETE BARRIER SIGN POST INSTALLATIONS	(REVISED ON MAY 24, 2016)182
M-601-2	<input type="checkbox"/>	DOUBLE CONCRETE BOX CULVERT (2 SHEETS) (REVISED ON NOVEMBER 25, 2015)	43	M-616-1	FIELD LABORATORY CLASS 1	144	S-614-22		TYPICAL MULTI-SIGN INSTALLATIONS	183
M-601-3	<input type="checkbox"/>	TRIPLE CONCRETE BOX CULVERT (2 SHEETS) (REVISED ON NOVEMBER 25, 2015)	44-45	M-620-1	FIELD LABORATORY CLASS 2 (2 SHEETS)	145-146	S-614-40	<input type="checkbox"/>	TYPICAL TRAFFIC SIGNAL INSTALLATION DETAILS (5 SHEETS)	(REVISED ON JUNE 17, 2016)184-188-
M-601-10		HEADWALL FOR PIPES	46	M-620-11	FIELD OFFICE CLASS 1	147	S-614-40A	<input type="checkbox"/>	ALTERNATIVE TRAFFIC SIGNAL INSTALLATION DETAILS (4 SHEETS)	(REVISED ON JUNE 17, 2016)189-192-
M-601-11		TYPE "S" SADDLE HEADWALLS FOR PIPE	47	M-620-12	FIELD OFFICE CLASS 2	148	S-614-41	<input type="checkbox"/>	TEMPORARY SPAN WIRE SIGNALS (REVISED ON APRIL 2, 2015)	193-
M-601-12		HEADWALLS AND PIPE OUTLET PAVING	48	M-629-1	SURVEY MONUMENTS (2 SHEETS)	149-150	S-614-42		CABINET FOUNDATION DETAIL (4 SHEETS)	194-197
M-601-20		WINGWALLS FOR PIPE OR BOX CULVERTS	49				S-614-43		TRAFFIC LOOP AND MISCELLANEOUS SIGNAL DETAILS (10 SHEETS)	198-207
M-603-1	<input type="checkbox"/>	METAL PIPE (4 SHEETS) (REVISED ON OCTOBER 02, 2014)	50-53				S-614-44	<input type="checkbox"/>	PEDESTAL POLE SIGNALS (2 SHEETS)	(REVISED ON JUNE 17, 2016)
M-603-2	<input type="checkbox"/>	REINFORCED CONCRETE PIPE (REVISED ON OCTOBER 02, 2014)	54				S-614-50	<input type="checkbox"/>	STATIC SIGN MONOTUBE STRUCTURES (12 SHEETS)	208-219
M-603-3	<input type="checkbox"/>	PRECAST CONCRETE BOX CULVERT	55				S-614-60	<input type="checkbox"/>	DYNAMIC SIGN MONOTUBE STRUCTURES (14 SHEETS)	(REVISED ON JUNE 17, 2016)220-233
M-603-4	<input type="checkbox"/>	CORRUGATED POLYETHYLENE PIPE (AASHTO M294)	56				S-627-1	<input checked="" type="checkbox"/>	PAVEMENT MARKINGS (8 SHEETS)	(REVISED ON FEBRUARY 8, 2017)234-238-
M-603-5	<input type="checkbox"/>	POLYVINYL CHLORIDE (PVC) PIPE (AASHTO M304)	57				S-630-1	<input type="checkbox"/>	TRAFFIC CONTROLS FOR HIGHWAY CONSTRUCTION (24 SHEETS)	(REVISED ON JUNE 23, 2016)239-258
M-603-6	<input type="checkbox"/>	STEEL REINFORCED POLYETHYLENE RIBBED PIPE (AASHTO MP 20) (NEW ON APRIL 30, 2015)	58-59				S-630-2	<input checked="" type="checkbox"/>	BARRICADES, DRUMS, CONCRETE BARRIERS (TEMP.) AND VERTICAL PANELS (REVISED ON JUNE 23, 2016)	259
M-603-10		CONCRETE AND METAL END SECTIONS (2 SHEETS)	60				S-630-3		FLASHING BEACON (PORTABLE) DETAILS	260
M-604-10		INLET, TYPE C	61				S-630-4		STEEL SIGN SUPPORT (TEMPORARY) INSTALLATION DETAILS (2 SHEETS)	261-262
M-604-11		INLET, TYPE D	62				S-630-5	<input type="checkbox"/>	PORTABLE RUMBLE STRIPS (TEMPORARY) (2 SHEETS)	(REVISED ON AUGUST 13, 2015)263-264-
M-604-12		CURB INLET TYPE R (2 SHEETS)	63				S-630-6		EMERGENCY PULL-OFF AREA (TEMPORARY)	265
M-604-13		CONCRETE INLET TYPE 13	64				S-630-7		ROLLING ROADBLOCKS FOR TRAFFIC CONTROL (3 SHEETS)	266-268
M-604-20		MANHOLES (3 SHEETS)	65-67							
M-604-25		VANE GRATE INLET (5 SHEETS)	68-72							
M-605-1		SUBSURFACE DRAINS	73							
M-606-1	<input type="checkbox"/>	GUARDRAIL TYPE 3 W-BEAM (20 SHEETS) (REVISED ON OCTOBER 27, 2014)	74-92							
M-606-1	<input type="checkbox"/>	MIDWEST GUARDRAIL SYSTEM (MGS) TYPE 3 W-BEAM 31 INCHES (20 SHEETS) (REVISED ON FEBRUARY 8, 2018)	93-96							
M-606-13	<input type="checkbox"/>	GUARDRAIL TYPE 7 F-SHAPE BARRIER (4 SHEETS) (REVISED ON AUGUST 30, 2013)	97-99							
M-606-14		PRECAST TYPE 7 CONCRETE BARRIER (3 SHEETS)	99							
M-606-15	<input type="checkbox"/>	GUARDRAIL TYPE 9 SINGLE SLOPE BARRIER (11 SHEETS) (REVISED ON JULY 16, 2018)								

COLORADO
 DEPARTMENT OF TRANSPORTATION
M&S STANDARDS PLANS LIST
 July 04, 2012
 Revised on July 16, 2018

ALL OF THE M&S STANDARD PLANS, AS SUPPLEMENTED AND REVISED, APPLY TO THIS PROJECT WHEN USED BY DESIGNATED PAY ITEM OR SUBSIDIARY ITEM.

NEW OR REVISED STANDARD PLAN SHEETS APPLICABLE TO THIS PROJECT, INDICATED BY A MARKED BOX WILL BE ATTACHED TO THE PLANS.

Computer File Information		Sheet Revisions		STANDARDS PLANS		STANDARDS PLAN NO.	
Creation Date: 07/04/12	Initials: JBK	Date:	Comments	LIST		STANDARDS PLANS LIST	
Last Modification Date: 07/16/18	Initials: LTA						
Full Path: www.coloradodot.info/business/designsupport				Issued By: Project Development Branch July 4, 2012		Sheet No. 1 of 1	
Drawing File Name: Standards Plans List.dgn							
CAD Ver.: MicroStation V8	Scale: Not to Scale	Units: English					

B
L-10
NOT TO SCALE

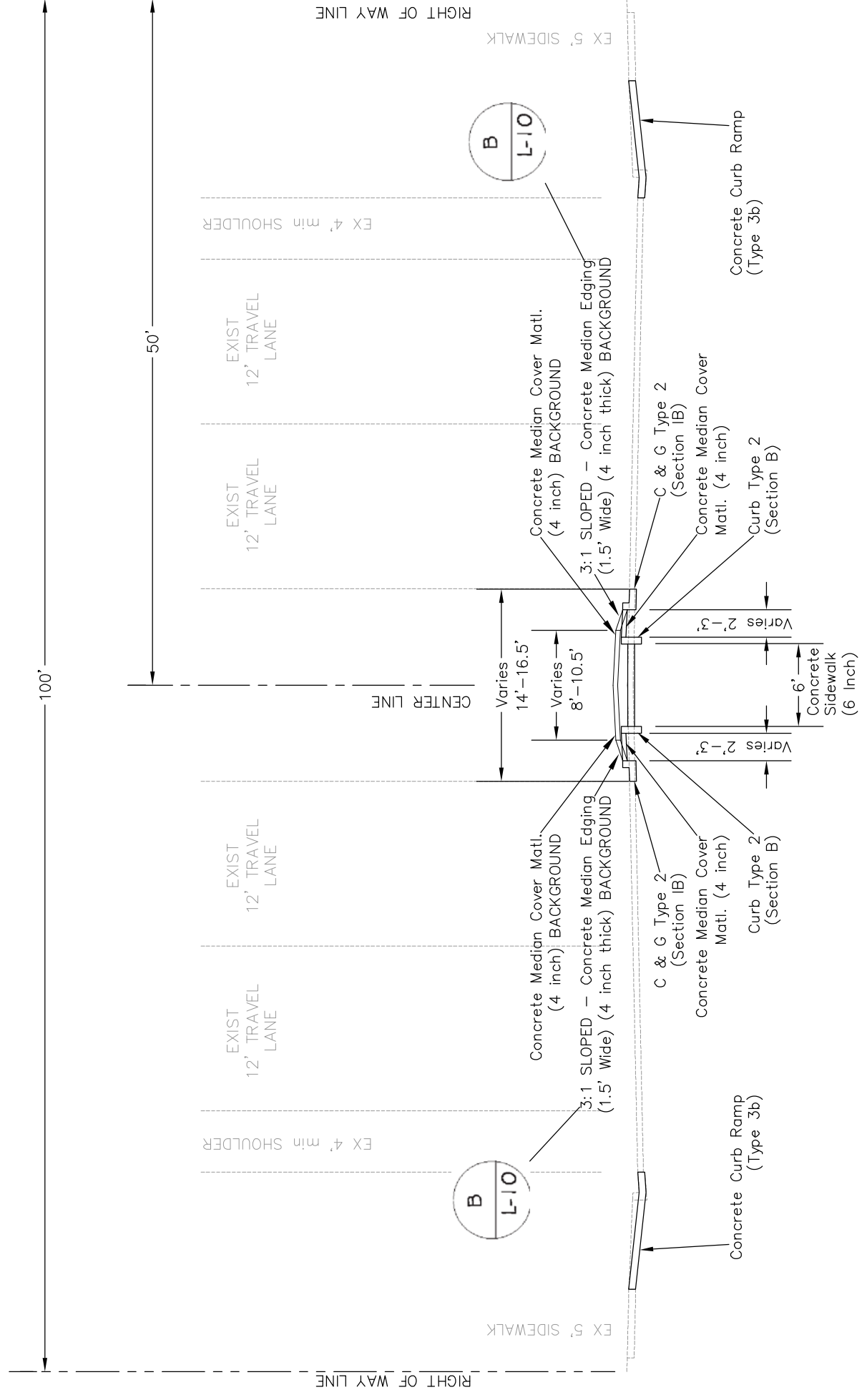
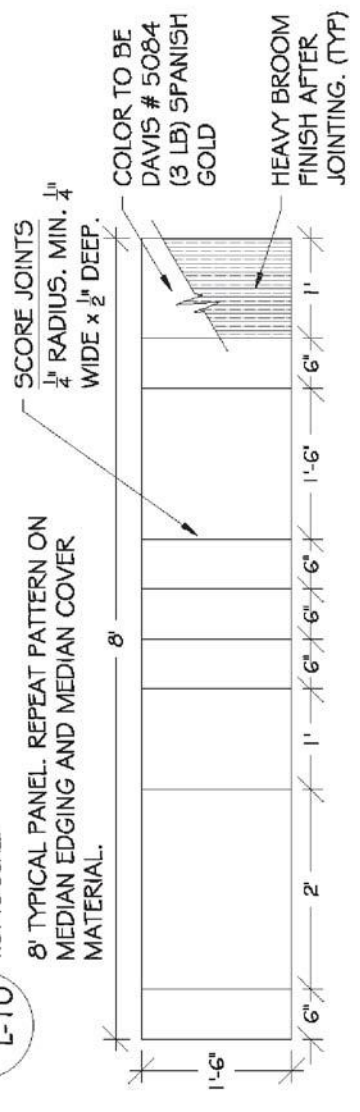

Note:

- SEE THE STAKING PLAN AND THE 0.1 FOOT CONTOUR PLAN FOR INFORMATION ON EXACT PAY ITEM LOCATIONS AND GRADES
- THE UNIT COST FOR ALL CONCRETE PAY ITEMS SHOWN SHALL INCLUDE 6" OF CLASS 6 UNDERLYING AGGREGATE BASE COURSE - NO SEPARATE PAY.

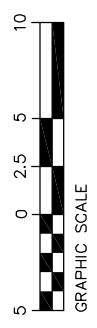

Colorado Department of Transportation 606 South 9th Street Grand Junction, CO, 81501 Phone: 970-683-6351 FAX: 970-683-6369 Region 3 SHY	0000	Sheet Revisions Date: _____ Comments: _____ Init.: _____		As Constructed No Revisions: _____ Revised: _____ Void: _____		TYPICAL SECTION		Project No./Code SHO M555-033	
		CITY OF Grand Junction COLORADO 333 West Ave. Grand Junction, CO, 81501 Phone: 970-244-1554		Designer: JCS Detailer: JCS Sheet Subset: Typical Sheet Number: 3		Structure Numbers: 22497 Subset Sheets: 1 of 1		Project No./Code SHO M555-033	

CONSTRUCTION

WHERE EXISTING ASPHALT PAVEMENT, CONCRETE PAVEMENT, OR CONCRETE SIDEWALK IS TO BE REMOVED, IT SHALL BE CUT FULL DEPTH TO A NEAT WORK LINE WITH A SAW OR CUTTING WHEEL AS APPROVED BY THE ENGINEER. CUT FACES SHALL NOT REMAIN OVERNIGHT. THIS WORK WILL NOT BE PAID FOR SEPARATELY BUT SHALL BE CONSIDERED SUBSIDIARY TO THE WORK.

DEPTH OF MOISTURE - DENSITY CONTROL FOR THIS PROJECT SHALL BE AS FOLLOWS:

- A. EXCAVATION REQUIRED FOR COMPACTION OF BASES OF CUTS AND FILLS WILL BE CONSIDERED AS SUBSIDIARY TO THAT OPERATION, AND WILL NOT BE PAID FOR SEPARATELY

UNLESS OTHERWISE DIRECTED BY THE ENGINEER, THE CONTRACTOR SHALL LIMIT CONSTRUCTION ACTIVITIES TO THOSE AREAS WITHIN THE LIMITS OF DISTURBANCE AS SHOWN ON THE PLANS. ANY DISTURBANCE BEYOND THESE LIMITS SHALL BE RESTORED TO ORIGINAL CONDITION BY THE CONTRACTOR AT THEIR OWN EXPENSE. CONSTRUCTION ACTIVITIES IN ADDITION TO NORMAL CONSTRUCTION PROCEDURES SHALL INCLUDE THE PARKING OF VEHICLES OR EQUIPMENT, DISPOSAL OF LITTER, AND ANY OTHER ACTION WHICH WOULD ALTER EXISTING CONDITIONS.

THE HORIZONTAL AND VERTICAL GEOMETRY FOR THE CURB, CUTTER AND SIDEWALK IS SHOWN GRAPHICALLY ON THE STAKING PLANS.

WATER SHALL BE USED AS A DUST PALLIATIVE WHERE REQUIRED. APPLICATION SHALL BE AS DIRECTED BY THE ENGINEER. WATER AS A DUST PALLIATIVE AND ANY OTHER WETTING SHALL BE INCLUDED IN THE WORK AND WILL NOT BE PAID SEPARATELY.

WATER SOURCE USED FOR MOISTURE DENSITY CONTROL SHALL BE THE CONTRACTOR'S RESPONSIBILITY AND SHALL BE FREE OF EXCESSIVE SEDIMENTS OR OTHER CONTAMINANTS THAT MAY BE DETRIMENTAL TO EMBANKMENTS, SUB-BASES, AND BASE COURSE MATERIAL.

DURING CONSTRUCTION ACTIVITIES THE CONTRACTOR SHALL KEEP ALL WORK EQUIPMENT AND MATERIALS WITHIN THE EASEMENT AND/OR RIGHT OF WAY LIMITS.

THE FOLLOWING CLEAR ZONE CRITERIA SHALL BE USED DURING THIS PROJECT: 10 FEET ON HORIZON DRIVE.

SULFATE RESISTANT CONCRETE FOR THIS PROJECT SHALL BE CLASS 2 (TYPE I-II SULFATE RESISTANT CEMENT). WATER SOLUBLE SULFATE LEVELS WERE ENCOUNTERED IN THE SITE SOILS IN CONCENTRATIONS AS HIGH AS 0.5%.

EXCAVATION REQUIRED FOR COMPACTION OF BASES OF CUTS AND FILLS WILL BE CONSIDERED AS SUBSIDIARY TO THAT OPERATION AND WILL NOT BE PAID FOR SEPARATELY.

THE CONTRACTOR SHALL BE REQUIRED TO FIELD VERIFY LENGTHS, ELEVATIONS, LOCATIONS, AND THICKNESS BEFORE CONSTRUCTION.

NO VERTICAL SLOPES SHALL BE LEFT OVERNIGHT UNPROTECTED. ALL UNPROTECTED VERTICAL SLOPES SHALL BE FLATTENED TO A 4:1 SIDE SLOPE PRIOR TO THE END OF THE WORK DAY, OR AS DIRECTED BY THE ENGINEER.

FINAL STRIPING WILL BEGIN AT A POINT THAT MATCHES THE ADJACENT STRIPING LOCATION AND SPACING.

PERFORMED THERMOPLASTIC PAVEMENT MARKING (INLAD) EDGING SHALL BE STRAIGHT AND UNIFORM, AND UNIFORMLY ADHERED TO THE PAVEMENT.

ACCEPTANCE OF CONCRETE PAVEMENT SHALL BE BASED ON COMPRESSIVE STRENGTH.

THE CONTRACTOR WILL BE RESPONSIBLE FOR THE ADJUSTMENT OF ALL VALVE BOXES AND MANHOLES WITHIN THE PROJECT LIMITS. THE CONTRACTOR SHALL NOTIFY THE IMPACTED UTILITY COMPANY AT LEAST 48 HOURS PRIOR TO ANY WORK BEING ACCOMPLISHED.

ANY EXISTING SIGNS OR SIGNS TO BE RESET THAT ARE DAMAGED BY THE CONTRACTOR SHALL BE REPAIRED OR REPLACED AT NO ADDITIONAL COST TO THE PROJECT.

MAGNESIUM CHLORIDE SOLUTION SHALL BE USED AS A SEAL COAT WHERE REQUIRED. LOCATIONS SHALL BE ORDERED AND DIRECTED BY THE ENGINEER.

THIS PROJECT IS DESIGNATED AS NON-SIGNIFICANT.

UTILITIES

THE CONTRACTOR SHALL PROTECT EXISTING UTILITIES BY USING EVERY REASONABLE MEANS POSSIBLE, INCLUDING FIELD LOCATION OF THE UTILITY, REPAIR OF DAMAGE TO THE EXISTING UTILITIES DURING CONSTRUCTION SHALL BE THE RESPONSIBILITY OF THE CONTRACTOR. THE CONTRACTOR SHALL DOCUMENT THE CONDITION OF EXISTING UTILITIES (VISIBLE FACILITIES) WITH THE ENGINEER AND UTILITY REPRESENTATIVES PRIOR TO COMMENCING CONSTRUCTION ACTIVITIES.

EXISTING UTILITY LINES AS SHOWN ON THE PLAN SHEETS ARE PLOTTED FROM THE BEST AVAILABLE INFORMATION, (ASCE STANDARD QUALITY LEVEL B).

UTILITY WORK NOT COMPLETED PRIOR TO THE START OF THE CONTRACTOR'S OPERATIONS WILL REQUIRE COORDINATION WITH CONTRACT WORK IN ACCORDANCE WITH SUBSECTION 105.11 OF THE STANDARD SPECIFICATIONS. THE CONTRACTOR SHALL COORDINATE AND COOPERATE WITH UTILITY OWNERS IN THEIR REMOVAL, ADJUSTMENT, AND/OR RELOCATION OPERATIONS SO THAT THE UTILITY WORK CAN BE ACCOMPLISHED WITHOUT IMPACTING THE CONSTRUCTION SCHEDULE.

THE CONTRACTOR SHALL COMPLY WITH ARTICLE 1.5 OF TITLE 9, CRS ("EXCAVATION REQUIREMENTS") WHEN EXCAVATING OR GRADING IS PLANNED IN THE AREA OF UNDERGROUND UTILITY FACILITIES. THE CONTRACTOR SHALL NOTIFY ALL AFFECTED UTILITIES AT LEAST TWO (2) BUSINESS DAYS, NOT INCLUDING THE ACTUAL DAY OF NOTICE, PRIOR TO COMMENCING SUCH OPERATIONS. THE CONTRACTOR SHALL CONTACT THE UTILITY NOTIFICATION CENTER OF COLORADO (UNCC) AT 811 OR 1-800-922-1987, TO HAVE LOCATIONS OF UNCC REGISTERED LINES MARKED BY MEMBER COMPANIES. ALL OTHER UNDERGROUND FACILITIES SHALL BE LOCATED BY CONTACTING THE RESPECTIVE OWNER. FOR CDOT OWNED UTILITY FACILITIES THE CONTRACTOR SHALL CALL THE CDOT REGION 3 TRAFFIC SECTION AT 970-683-6271 TO REQUEST LOCATES. UTILITY SERVICE LATERALS SHALL ALSO BE LOCATED PRIOR TO BEGINNING EXCAVATION OR GRADING.

LOCATION AND NOTIFICATION OF BOTH UNCC MEMBER AND NON-MEMBER UTILITIES IS THE CONTRACTOR'S RESPONSIBILITY.

IT IS SUGGESTED THAT THE CONTRACTOR INITIATE A REQUEST TO XCEL ENERGY, CENTURYLINK AND CHARTER COMMUNICATIONS FOR ANY CONSTRUCTION RELATED TO TEMPORARY ELECTRICAL POWER AND TELEPHONE SERVICE AS SOON AS POSSIBLE.

THE CONTRACTOR SHALL BE RESPONSIBLE FOR VERIFYING THE LOCATION AND DEPTH OF ALL EXISTING UTILITIES AT PIPES, CULVERTS, CBC'S, AND OTHER AREAS OF EXCAVATION AS NECESSARY TO ENSURE THE UTILITIES WILL NOT BE IMPACTED.

POTHOLING OF AN AREA SHALL TAKE PLACE 10 DAYS PRIOR TO COMMENCEMENT OF CONSTRUCTION OPERATIONS IN THAT AREA.

THE CONTRACTOR SHALL:

- A. NOTIFY UTE WATER, CITY OF GRAND JUNCTION WATER AND SEWER, AND ALL CUSTOMERS AFFECTED BY OUTAGE OF WATER DURING CONSTRUCTION AT LEAST 48 HOURS PRIOR TO DISRUPTION OF SERVICE.
- B. NOTIFY GRAND JUNCTION POLICE DEPARTMENT, GRAND JUNCTION FIRE DEPARTMENT, GRAND JUNCTION DEPARTMENT OF PUBLIC WORKS, MESA COUNTY SHERIFF'S OFFICE, MESA COUNTY PUBLIC WORKS, COLORADO STATE PATROL, UTE WATER CONSERVANCY DISTRICT, UNITED STATES POSTAL SERVICE, GRAND VALLEY TRANSIT, AND FIRST STUDENT BUS COMPANY OF ALL STREET CLOSINGS AND EXISTING FIRE HYDRANTS TO BE TAKEN OUT OF SERVICE AT LEAST 48 HOURS PRIOR TO THE START OF CONSTRUCTION AND UPDATED ON A BI-WEEKLY BASIS.
- C. WHEN EXCAVATING BELOW EXISTING WATER OR SANITARY SEWER LINES THE CONTRACTOR SHALL SUBMIT, FOR APPROVAL, THE METHOD BY WHICH EXISTING WATER OR SANITARY SEWER LINES SHALL BE PROTECTED AND SUPPORTED.
- D. THE STATION POINT AND ELEVATION SHOWN ON THE PLANS FOR THE STANDARD STORM INLET AND MEDIAN INLET IS LOCATED AT THE CENTER OF THE INLET BOX. THE STATION POINT OF ALL OTHER DRAINAGE, IRRIGATION, AND SANITARY SEWER STRUCTURES IS LOCATED AT THE CENTER POINT OF THE STRUCTURE AS WELL.
- E. WATER LINE TRENCH PIPE ZONE MATERIAL, FROM 6-INCHES ABOVE THE TOP OF PIPE TO BOTTOM OF TRENCH (4-INCHES MINIMUM BELOW THE BOTTOM OF PIPE) SHALL NOT BE PAID FOR SEPARATELY, BUT WILL BE INCIDENTAL TO THE PIPE COST.

ESTIMATED QUANTITIES

FOR PRELIMINARY PLAN QUANTITIES, THE FOLLOWING RATES OF APPLICATION WERE USED:

TACK COAT DILUTED EMULSIFIED ASPHALT (SLOW SETTING)..... 0.1 GALS/SQ YD (DILUTED)
HOT MIX ASPHALT (GRADING SX)..... 110 LBS/SQ YD/INCH
AGGREGATE BASE COURSE (CLASS 1)..... 133 LBS/CU FT.
AGGREGATE BASE COURSE (CLASS 3)..... 133 LBS/CU FT.
AGGREGATE BASE COURSE (CLASS 6)..... 133 LBS/CU FT.

DILUTED EMULSIFIED ASPHALT FOR TACK COAT SHALL CONSIST OF 1 PART EMULSIFIED ASPHALT AND 1 PART WATER.

IT IS ESTIMATED THAT THE FOLLOWING SHALL BE REQUIRED FOR THIS PROJECT, AS DIRECTED BY THE PROJECT ENGINEER FOR MISCELLANEOUS WORK:

201-00000 Clearing and Grubbing 1 LS
202-05004 Sowing Concrete (4 inch) 24 LF
202-06008 Sowing Concrete (8 inch) 56 LF
203-01597 Potholing 24 HR
207-00205 Topsoil 2 CY
208-00207 Erosion Control Management 15 DAY
613-10000 Wiring 1 LS
620-00020 Sanitary Facility 1 LS
625-00000 Construction Surveying 1 LS
626-00000 Mobilization 1 LS
626-01103 Public Information Services (Tier III) 1 LS
MCR *Minor Contract Revisions

ASPHALT MILLINGS MAY BE SUBSTITUTED FOR ABC CLASS 6 AS APPROVED BY PROJECT ENGINEER. ANY USE OF ASPHALT MILLINGS THAT DOES NOT MEET THE APPROVED REQUIREMENTS SHALL BE REMOVED AND REPLACED AT THE CONTRACTOR'S EXPENSE.

ENVIRONMENTAL

THE CONTRACTOR SHALL BE RESPONSIBLE FOR THE ACCEPTANCE AND CONTROL OF ALL SURFACE AND SUBSURFACE DRAINAGE AND GROUNDWATER ENTERING THE PROJECT AREA. THE CONTRACTOR IS RESPONSIBLE FOR PROVIDING DEWATERING IF NEEDED AT NO ADDITIONAL COST TO THE PROJECT. DEWATERING METHODS SHALL BE APPROVED BY THE ENGINEER. THE CONTRACTOR SHALL OBTAIN A CONSTRUCTION DEWATERING PERMIT FROM THE COLORADO DEPARTMENT OF PUBLIC HEALTH AND ENVIRONMENT. THE PERMIT WILL NOT BE PAID FOR SEPARATELY BUT SHALL BE INCLUDED IN THE WORK.

WHENEVER SEDIMENT IS TRANSPORTED ONTO A PUBLIC ROAD, THE ROAD SHALL BE CLEANED AT THE END OF EACH DAY. SEDIMENT SHALL BE REMOVED FROM ROADS BY SHOVELING OR SWEEPING AND BE TRANSPORTED TO A CONTROLLED SEDIMENT DISPOSAL AREA. STREET WASHING SHALL NOT BE ALLOWED. STREET SWEEPING METHODS/OPERATIONS SHALL BE APPROVED BY THE ENGINEER PRIOR TO COMMENCEMENT OF SWEEPING OPERATIONS. OPEN STYLE MECHANICAL BROOM WILL NOT BE ALLOWED FOR STREET SWEEPING.

ALL STAGING AREAS AND EQUIPMENT SHALL BE KEPT OUTSIDE WETLAND AND RIPARIAN AREAS AND SHALL BE LOCATED AT LEAST 100 FEET FROM ANY WATERCOURSE.

THE CONTRACTOR SHALL ADDRESS LOCAL DRAINAGE DURING EACH PHASE OF CONSTRUCTION. THIS WORK WILL NOT BE PAID SEPARATELY BUT SHALL BE CONSIDERED SUBSIDIARY TO THE WORK.

ANY DEWATERING WILL NOT BE PAID FOR SEPARATELY, BUT SHALL BE INCIDENTAL TO THE PROJECT.

PROJECT UTILITY CONTACTS

CHARTER COMMUNICATIONS JEFF VALDEZ 970-263-2314
CITY OF GRAND JUNCTION (SANITATION) LEE COOPER 970-244-1590
CITY OF GRAND JUNCTION (PERSIGO SEWER SYSTEMS) LARRY BROWN 970-256-4168
CITY OF GRAND JUNCTION (FIBER OPTIC) PAUL JAGM 970-244-1591
CITY OF GRAND JUNCTION (IRRIGATION SPRINKLERS) MIKE VENDEGNA 970-254-3843
CENTURY LINK COMMUNICATIONS CHRIS JOHNSON 970-244-4311
UTE WATER DAVE PRISKE 970-242-7491
XCEL ENERGY (GAS) TILLMAN McSHOOLER970-244-2693
XCEL ENERGY (ELECTRIC) TILLMAN McSHOOLER970-244-2693

 Colorado Department of Transportation
606 South 9th Street
Grand Junction, CO, 81501
Phone: 970-683-6351 FAX: 970-683-6369
SHY

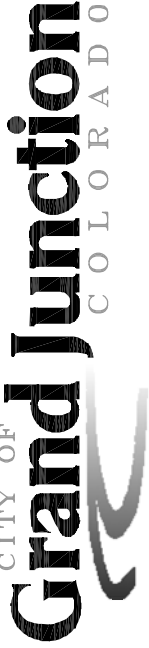
 CITY OF
Grand Junction
C O L O R A D O
333 West Ave. Grand Junction, CO, 81501 Phone: 970-244-1554

Sheet Revisions	
Date:	Comments

As Constructed	
No Revisions:	
Revised:	
Void:	

GENERAL NOTES		Project No./Code
Designer: JCS	Structure	SHO M555-033
Detailer: JCS	Numbers	22497
Sheet Subset: General	Sheet Sheets: 1 of 1	Sheet Number 4

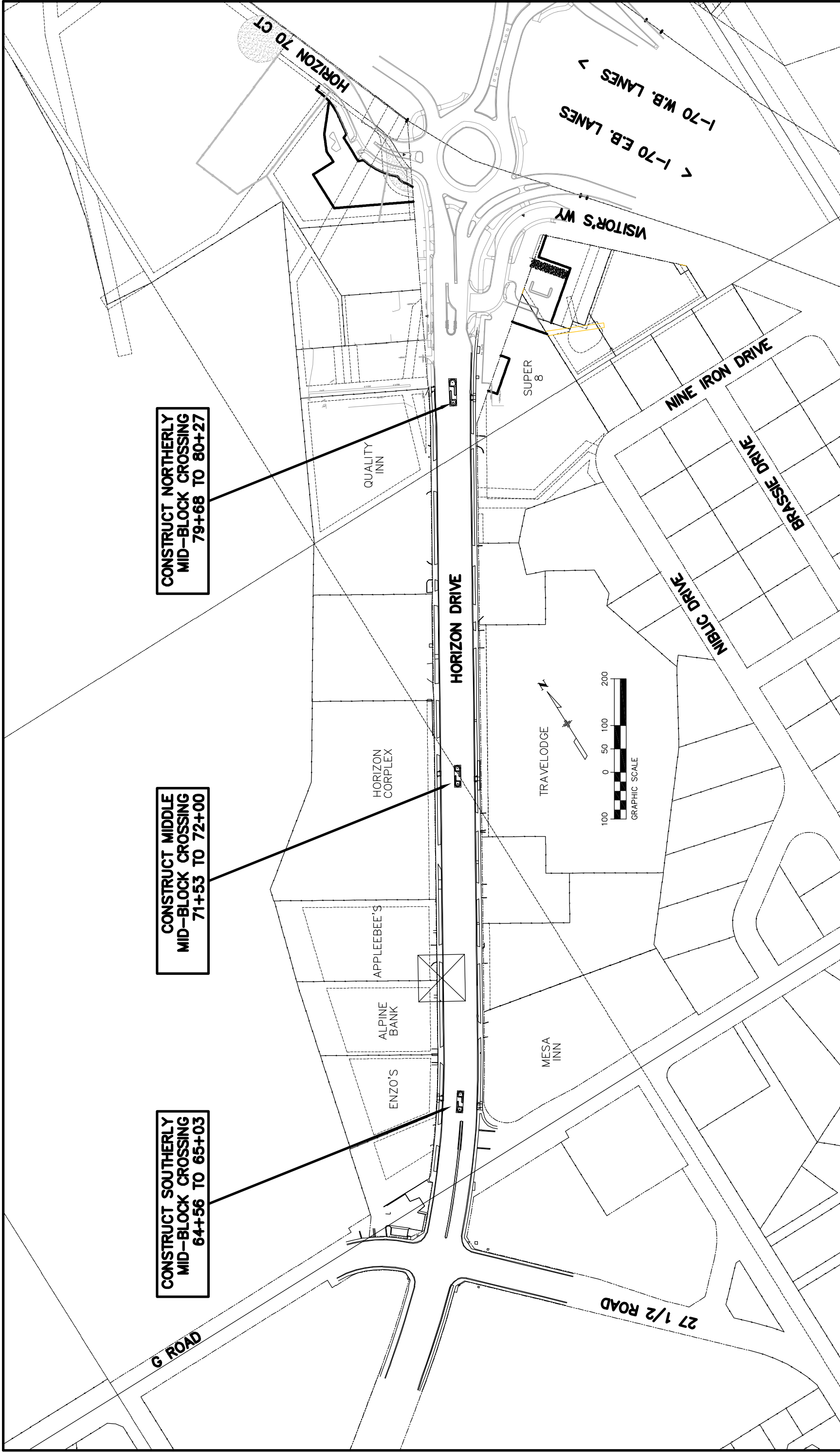

**CONSTRUCT NORTHERLY
MID-BLOCK CROSSING
79+68 TO 80+27**

**CONSTRUCT MIDDLE
MID-BLOCK CROSSING
71+53 TO 72+00**

**CONSTRUCT SOUTHERLY
MID-BLOCK CROSSING
64+56 TO 65+03**

Colorado Department of Transportation 606 South 9th Street Grand Junction, CO, 81501 Phone: 970-683-6351 FAX: 970-683-6369 SHY Region 3	CITY OF <h1 style="margin:0;">Grand Junction</h1> COLORADO 333 West Ave. Grand Junction, CO, 81501 Phone: 970-244-1554	PROJECT OVERVIEW		Project No./Code SHO M555-033										
		As Constructed No Revisions: Revised: Void:	Designer: JCS Detailer: JCS	Structure Numbers: - - -	Sheet No. / Code SHO M555-033 22497 1 of 1 Sheet Number 6									
<table border="1" style="width:100%; border-collapse: collapse;"> <thead> <tr> <th colspan="2">Sheet Revisions</th> </tr> <tr> <th>Date:</th> <th>Comments</th> </tr> </thead> <tbody> <tr> <td> </td> <td> </td> </tr> <tr> <td> </td> <td> </td> </tr> <tr> <td> </td> <td> </td> </tr> </tbody> </table>		Sheet Revisions		Date:	Comments							Sheet Subsets: General 1 of 1 Subset Sheets: 6		
Sheet Revisions														
Date:	Comments													

TABULATION OF REMOVALS

STATION	(202-00026) REMOVAL OF SLOPE AND DITCH PAVING SY		(202-00195) REMOVAL OF MEDIAN COVER SY		(202-00200) REMOVAL OF SIDEWALK SY		(202-00203) REMOVAL OF CURB AND GUTTER LF		(202-00220) REMOVAL OF ASPHALT MAT SY		COMMENTS
	Plan	As Const	Plan	As Const	Plan	As Const	Plan	As Const	Plan	As Const	
HORIZON DRIVE											
64+76.31 LT TO 64+94.72 LT					10						IN FRONT OF ENZO'S
64+74.84 LT TO 64+97.77 LT							10				3/4" WASHED ROCK IN FRONT OF ENZO'S
64+80.42 LT TO 64+90.87			14								IN FRONT OF ENZO'S
64+56.48 TO 65+03.36							14		75		SOUTH CROSSING
64+65 RT TO 64+79 RT											IN FRONT OF MESA INN
64+75 RT TO 64+83 RT			4								RIVER COBBLE IN FRONT OF MESA INN
64+65 RT TO 64+83 RT					20						IN FRONT OF MESA INN
67+45 LT					6						IN FRONT OF ALPINE BANK TO CONNECT ELECT - UTIL PLAN
71+74.84 LT TO 71+90.06 LT			10								GRASS IN FRONT OF HORIZON CORPLEX
71+77.01 LT TO 71+87.02 LT							10				IN FRONT OF HORIZON CORPLEX
71+53.02 TO 71+99.99									75		MIDDLE CROSSING
71+65.32 RT TO 71+75.42 RT							10				IN FRONT OF TRAVELODGE
71+46.21 RT TO 72+09.08 RT	36										IN FRONT OF TRAVELODGE
71+46.21 RT TO 72+09.08 RT					35						IN FRONT OF TRAVELODGE
71+46.21 RT TO 72+09.08 RT			7								GRASS IN FRONT OF TRAVELODGE
80+00.78 LT TO 80+12.18 LT			9								1 1/2" TAN GRANITE IN FRONT OF QUALITY INN
80+00.30 LT TO 80+10.32 LT							10				IN FRONT OF QUALITY INN
79+68.21 TO 80+26.83									103		NORTH CROSSING
79+80.24 RT TO 79+90.24 RT							10				IN FRONT OF SUPER 8
79+75.83 RT TO 79+93.82 RT			10								GRASS IN FRONT OF SUPER 8
79+75.83 RT TO 79+93.82 RT											IN FRONT OF SUPER 8
79+75.83 RT TO 79+93.82 RT			2								GRASS IN FRONT OF SUPER 8
TOTAL	36		56		81		64		253		

 Colorado Department of Transportation
 606 South 9th Street
 Grand Junction, CO, 81501
 Phone: 970-683-6351 FAX: 970-683-6369
 Region 3
 SHY

Sheet Revisions	
Date:	Init:
Comments	

CITY OF

 333 West Ave. Grand Junction, CO, 81501 Phone: 970-244-1554

As Constructed			
No Revisions:			
Revised:			
Void:			

Project No./Code	
SHO M555-033	
22497	
Sheet Number	7

TABULATION OF REMOVALS			
Designer:	JCS	Structure	
Detailer:	JCS	Numbers	
Sheet Subset:	TAB	Sheet	1 of 1

STATION	(613-01200) 2 inch ELECTRICAL CONDUIT (PLASTIC)		(613-07001) TYPE ONE PULL BOX		(613-40010) LIGHT STANDARD FOUNDATION		COMMENTS
	LF		EA		EA		
	Plan	As Const	Plan	As Const	Plan	As Const	
HORIZON DRIVE							
64+75.51, 42.62' LT			1				IN FRONT OF ENZO'S
64+79.10, 40.38' LT			1		1		IN FRONT OF ENZO'S
64+92.13, 42.73' LT							IN FRONT OF ENZO'S
64+75.51 LT TO 64+92.13 LT	10						
64+63.56					1		S. END OF SOUTH CROSSING IN MEDIAN
64+70.90, 0.86' RT			1				SOUTH CROSSING IN MEDIAN
64+80.93, 4.52' RT			1				SOUTH CROSSING IN MEDIAN
64+88.90, 0.93' LT			1				SOUTH CROSSING IN MEDIAN
64+63.56 TO 64+96.36	37						SOUTH CROSSING IN MEDIAN
64+84.34, 38.13' RT			1				IN FRONT OF MESA INN
64+80.39, 40.39' RT			1		1		IN FRONT OF MESA INN
64+76.46, 49.40' RT			1				IN FRONT OF MESA INN
64+69 RT TO 64+84.34 RT	30						IN FRONT OF MESA INN
67+44.98, 39.92' LT TO 67+46.18, 58.77' LT	20		1				PBX PLACE AT CONNECT TO ELECT IN FRONT OF ALPINE BANK TIE TO ELECT IN FRONT OF ALPINE BANK
71+72.26, 39.81' LT TO 71+87.78, 42.29' LT	20		1		1		IN FRONT OF HORIZON CORPLEX IN FRONT OF HORIZON CORPLEX IN FRONT OF HORIZON CORPLEX IN FRONT OF HORIZON CORPLEX
71+60.05, 0.62' LT TO 71+92.93, 0.67' LT	37		1		1		MIDDLE CROSSING IN MEDIAN MIDDLE CROSSING IN MEDIAN MIDDLE CROSSING IN MEDIAN MIDDLE CROSSING IN MEDIAN
71+64.71, 40.24' RT			1				IN FRONT OF TRAVELODGE
71+76.54, 40.40' RT			1		1		IN FRONT OF TRAVELODGE
71+81.18, 38.04' RT			1				IN FRONT OF TRAVELODGE
71+64.71, 40.24' RT TO 71+81.18, 38.04' RT	25						IN FRONT OF TRAVELODGE
79+97.39, 41.43' LT			1				IN FRONT OF QUALITY INN
79+98.86, 44.27' LT			1		1		IN FRONT OF QUALITY INN
80+11.12, 43.62' LT			1				IN FRONT OF QUALITY INN
79+97.39, 41.43' LT TO 80+11.12, 43.62' LT	10						IN FRONT OF QUALITY INN
79+75.88					1		NORTH CROSSING IN MEDIAN
79+83.19, 1.61' RT			1				NORTH CROSSING IN MEDIAN
79+95.29, 4.86' RT			1				NORTH CROSSING IN MEDIAN
80+08.46, 1.86' LT			1				NORTH CROSSING IN MEDIAN
79+75.88 TO 80+18.40	47						NORTH CROSSING IN MEDIAN
79+79.20, 43.97' RT			1				IN FRONT OF SUPER 8
79+91.36, 40.17' RT			1		1		IN FRONT OF SUPER 8
79+93.72, 40.30 RT			1				IN FRONT OF SUPER 8
79+79.20, 43.97' RT TO 79+93.72, 40.30 RT	25						IN FRONT OF SUPER 8
TOTAL	261		22		9		

Colorado Department of Transportation  606 South 9th Street Grand Junction, CO, 81501 Phone: 970-683-6351 FAX: 970-683-6369 Region 3	Sheet Revisions Date: _____ Comments _____ Init: _____		CITY OF Grand Junction COLORADO 333 West Ave. Grand Junction, CO, 81501 Phone: 970-244-1554	As Constructed No Revisions: _____ Revised: _____ Void: _____	TABULATION OF PULL BOXES, CONDUIT, AND LIGHT STANDARD FOUNDATIONS Designer: JCS Detailer: JCS Sheet Subset: TAB	Project No./Code SHO M555-033 22497 Sheet Number 10
	Structure Numbers JCS JCS 1 of 1	Subset Sheets: 1 of 1		Sheet Number 10		

TO ESTABLISH GEOMETRIC CONTROL FOR THE CONSTRUCTION OF THIS PROJECT, THE DEPARTMENT HAS PROVIDED THE FOLLOWING INFORMATION:

- Horizontal Control
- Vertical Control
- Roadway Alignment
- Original Terrain Data
- Other: _____

* Specify the information format, i.e., plan sheet, computer disk, computer printout, or other. The information marked is either contained on the plans or is available from the Engineer.

TYPE OF PROJECT

- Landscaping
- Signalization
- Safety Improvement
- Asphalt Overlay
- Concrete Overlay
- Minor Widening
- Major Reconstruction (Intersection Reconstruction)
- New Roadway Construction
- Bridge Replacement
- Bridge Widening
- New Bridge
- Other: _____

SURVEY WORK TO BE PERFORMED BY OTHERS: _____

WORK PERFORMED BY THE CONTRACTOR'S SURVEYOR UNDER SECTION 625:

- Establish and Maintain Project Centerline or Engineer Approved Offset Line(s)
- Verification and Maintenance of Horizontal and Vertical Control
- Verify or Determine existing grades and alignments
- Verify or Determine existing topography
- GPS/RIS (Global Positioning System/Robotic Total Station) Construction Machine Control
- Clearing and Grubbing Limits (Section 201)
- Removal Limits (Section 210)
- Excavation and Embankment (Section 203)
- Excavation
- Unclassified
- Stripping
- Muck
- Rock
- Borrow
- Other: _____
- Potholing
- Embankment
- Site Grading
- Erosion Control (Perm)
- Other: _____
- As Staked Earthwork Quantities

Slope Staking (Y/N)	Grid (Y/N)	Grade (Y/N)	Special Interval
Y	-	Y	25'
-	-	-	-
-	-	-	-
-	-	-	-
-	-	-	-

Excavation	Grade (Y/N)	Special Interval
Y	Y	25'
-	-	-
-	-	-
-	-	-
-	-	-

Grid (Y/N)	Grade (Y/N)	Special Interval	Special Offset
-	-	-	-
-	-	-	-
-	-	-	-
-	-	-	-
-	-	-	-

- Roadway Bases
- Untreated Subgrade
- Treated Subgrade
- Aggregate Base Course (Section 304)
- Reconditioning
- PMBB - Plant Mix Bituminous Base
- Other: _____

- Pavements
- HMA - Hot Mix Asphalt (Section 403)
- Concrete (Section 412)
- Heating & Sealing Treatment
- Prime Coat, Tack Coat & Rejuvenating Agent (Section 407)
- Seal Coat or Chip Seal (Section 409)
- Other: _____

Roadway Elements

- Curb and Gutter (Section 609)
- Drop inlets
- alignment and grades (Section 604)
- Retaining Walls
- Guard Rail (Section 606)
- Sidewalk (Section 608)
- Overlay Stationing
- Other: _____

Riprap (Perm) (Section 506)

Slope and Ditch Paving (Section 507)

Minor Structures

- Structure Excavation limits (Section 206)
- Culverts (Section 603)
- Culverts w/ Headwalls and Wingwalls (Section 601)
- Concrete Box Culverts w/ Headwalls and Wingwalls
- Pipes (Section 603)
 - Sanitary Sewer
 - Storm Sewer
 - Water
 - Irrigation
 - Miscellaneous
- Manholes (Section 604)
- Inlets (Section 604)
- Permanent Water Quality BMP (Section 208)
- Other: _____

Major Structures - Overhead Signs (Section 614), Concrete Box Culverts, Bridges - and all other structures assigned a structure number

- Structure Excavation limits (Section 206)
- Concrete Box Culverts (Section 603) w/ Headwalls and Wingwalls (Section 601)
- Piling locations and cut off elevations (Section 502)
- Caisson locations and elevations (Section 503)
- Footing locations, alignment, and elevations
- Abutment/Pier locations, alignment, and elevations
- Wingwall skew angles/offsets
- Structural concrete form locations
- Substructure As-constructed survey required for Bridges (Subsection 601.12) and Overhead signs (S-614-50)
- Bridge expansion joint(s) alignment and grade (longitudinal and transverse)
- Deck grades at Girder 10th or "n" th point locations and elevations
- Slope and Ditch Paving (Section 507)
- Other: _____

Fencing (Section 607)

- Temporary
- Permanent
- Sound Barrier
- Other: _____
- Delineators (Section 612)
- Temporary
- Permanent

Lighting (Section 613) and Traffic Control Devices (Permanent) (Section 614)

- Signal pole locations and elevations
- Light pole locations and elevations
- Sign locations
- Field verify sign post locations, elevations, and lengths before fabrication.
- Other: _____

- Pavement Marking (Section 627)
 - Striping (Temp)
 - Striping (Perm)
 - Symbols
 - Other: _____
- Temporary Lighting and Construction Traffic Control Devices (Section 630)
 - Signal pole locations and elevations (Temp)
 - Light pole locations and elevations (Temp)
 - Sign Locations (Temp)
 - Other: _____
- All Easements (Temp Staking by P.L.S. Only)
- Right of Way (Temp Staking by P.L.S. Only)

WORK PERFORMED BY THE CONTRACTOR'S SURVEYOR UNDER SECTION 629:

- Monumentation (Section 629)
 - Control
 - Right of Way
 - Land corners, Aliquot corners
 - Easements
 - Reference the specified existing monuments: ** _____
 - Replace the specified existing monuments: ** _____
 - Locate monuments. It is estimated _____ hours are required.

NOTE: All 629 items shall include adequate research, calculations, and evaluations of evidence for monuments to be set.

** A Tabulation of Survey Monuments may be provided on the plans.

GENERAL NOTES:

1. Unless indicated otherwise on this Survey Tabulation Sheet, all survey work and staking intervals shall be done in accordance with the latest edition of the CDOT Survey Manual.
2. Adequate information for establishing lines, grades, and locations for all work items have been specified on the plans. Any additional information required to stake the item or element shall be generated by the Contractor's surveyor.
3. The Contractor's surveyor shall provide an estimate of the man-hours necessary to complete the work items indicated on this sheet. A copy of this sheet, with the estimated man-hours written on the blank line to the left of the specified items, shall be submitted with the Survey Schedule to the Engineer 14 days prior to the Pre-Construction Meeting.
4. Stakes and Monuments which are damaged or destroyed by the progress of construction shall be replaced by the Contractor at no additional cost to the Department.
5. Prior to beginning work on any subsequent operation, such as placing base course or paving, the Contractor shall certify in writing to the Engineer that the final grade is within specified tolerance.
6. The Contractor's surveyor shall perform all field surveying and calculations necessary to tie plan grades into field grades.
7. The Contractor shall coordinate construction staking on the project with any utility work.
8. Fieldbooks shall contain daily records of points set and or measurements observed. The information recorded shall contain: date, crew members' names, point no., description, staking information, and sketches. If the survey information is collected electronically, information recorded shall be provided to the Project Engineer in a hard copy format that is intuitive, clear and related to the supplemental information recorded in the field books. All linear surveys, such as slope stakes and blue tops, shall have the station and offset information related to the measured information. Non-linear surveys such as structures staking shall have sketches relating electronic information, such as point numbers, to the sketch.
9. The Contractor's surveyor shall submit the following fieldbooks to the Engineer.
 - Horizontal Control (Primary & Secondary)
 - Vertical Control (i.e. Benchmarks)
 - Property Pin Ties
 - Horizontal Alignment
 - Grading
 - Slope Staking
 - Minor Structures
 - Major Structures
 - One fieldbook for each work category shown on this sheet
 - Other Fieldbook(s): _____



Colorado Department of Transportation
 606 South 9th Street
 Grand Junction, CO, 81501
 Phone: 970-683-6351 FAX: 970-683-6369
 SHY

Sheet Revisions	
Date:	Comments



333 West Ave. Grand Junction, CO, 81501 Phone: 970-244-1554

As Constructed	
No Revisions:	
Revised:	
Void:	

SURVEY TABULATIONS			Project No./Code
Designer: JCS	Structure Numbers	-	SHO M555-033
Detailer: JCS	Structure Numbers	-	22497
Sheet Subset: Survey Tab	Sheet Sheets: 1 of 1		Sheet Number

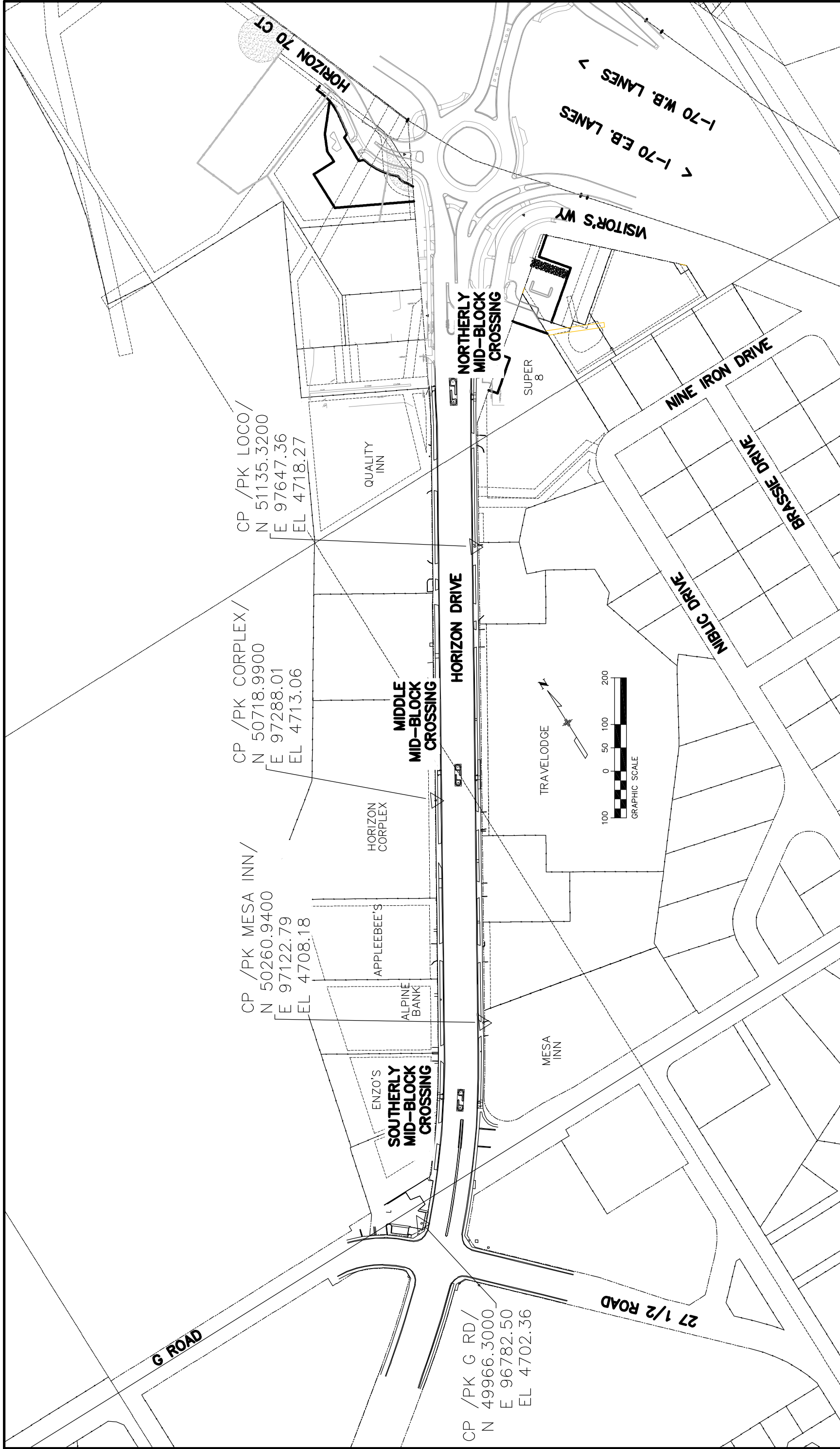

Colorado Department of Transportation  Region 3 606 South 9th Street Grand Junction, CO, 81501 Phone: 970-683-6351 FAX: 970-683-6369 SHY	Sheet Revisions Date: _____ Init: _____ Comments: _____		As Constructed No Revisions: _____ Revised: _____ Void: _____		SURVEY CONTROL PLAN Designer: JCS Detailer: JCS Sheet Subset: General		Project No./Code SHO M555-033
	City of Grand Junction COLORADO 333 West Ave. Grand Junction, CO, 81501 Phone: 970-244-1554		Structure Numbers: _____ Subset Sheets: 1 of 1		Sheet Number: 12		22497

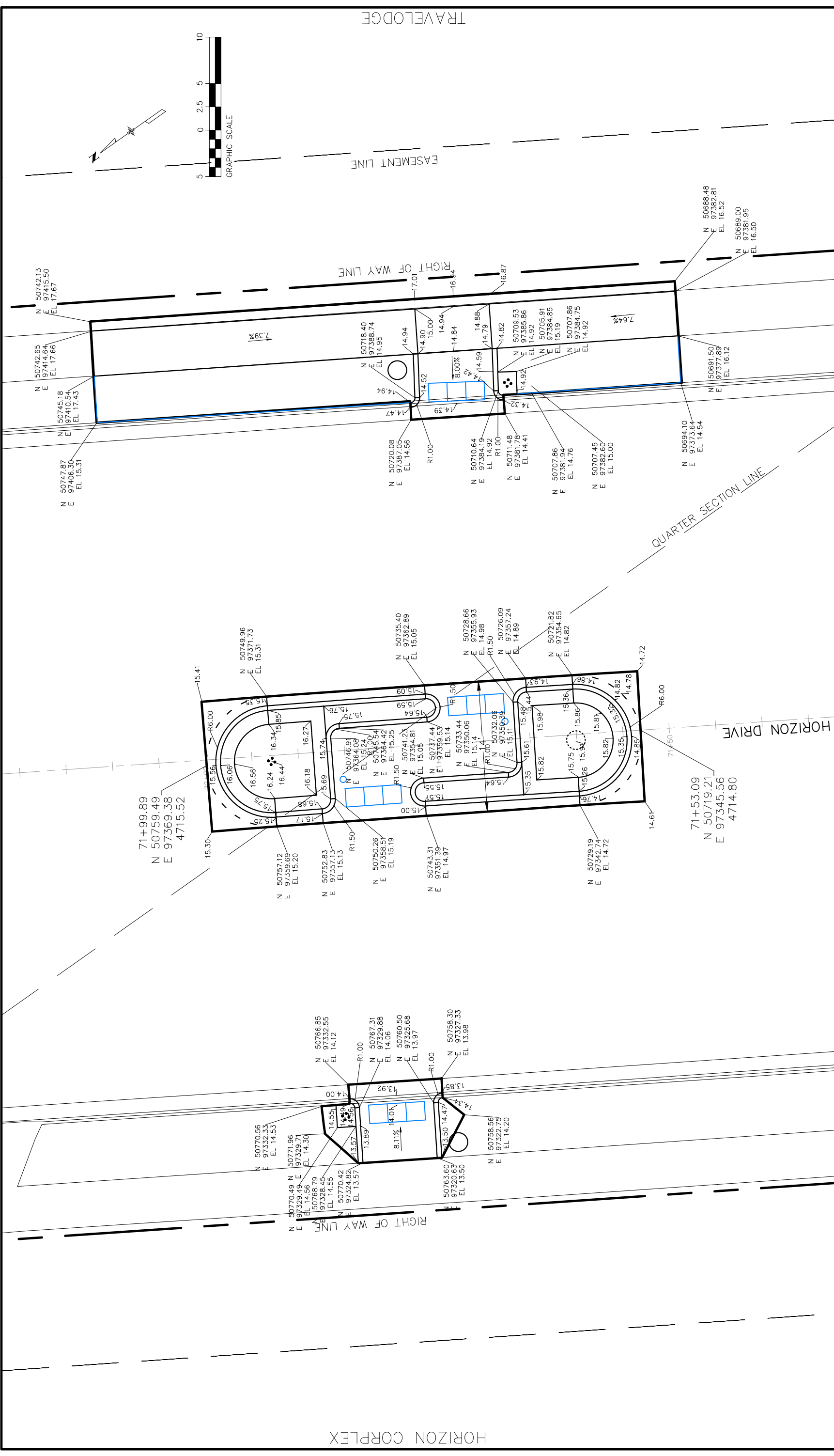

CITY OF
Grand Junction
 COLORADO

333 West Ave. Grand Junction, CO, 81501 Phone: 970-244-1554

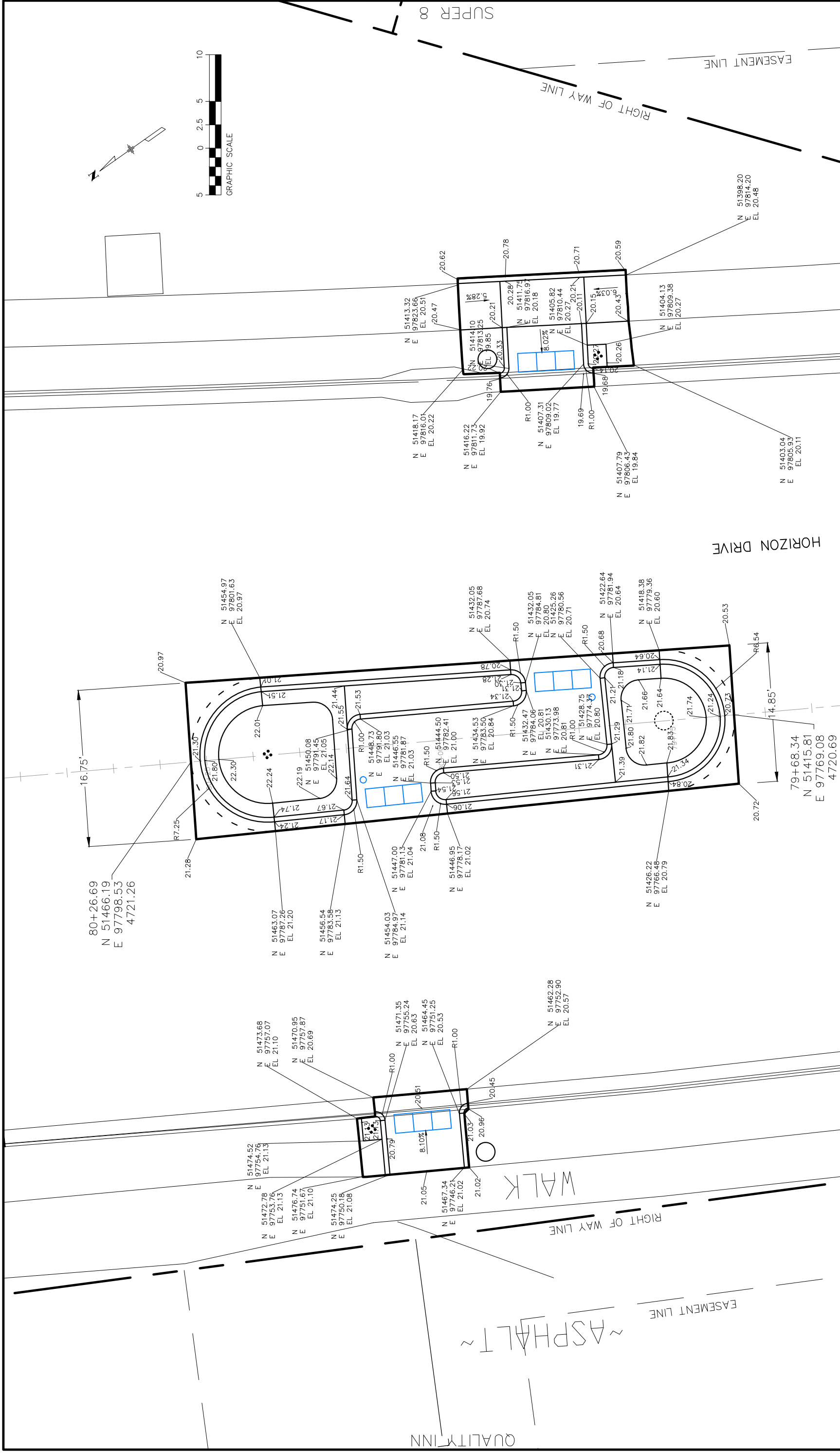

Colorado Department of Transportation  Region 3	606 South 9th Street Grand Junction, CO, 81501 Phone: 970-683-6351 FAX: 970-683-6369		SHY
	Sheet Revisions		
Date:		Comments	Init.
As Constructed		No Revisions:	
Revised:		Designer: JCS	
Void:		Detailer: JCS	
Sheet Subsets: General		Structure Numbers	
Sheet Subsets:		Subset Sheets: 1 of 1	
Project No./Code		SHO M555-033	
10th SCALE STAKING PLAN NORTHERLY		Sheet Number 15	

CITY OF
Grand Junction
 COLORADO

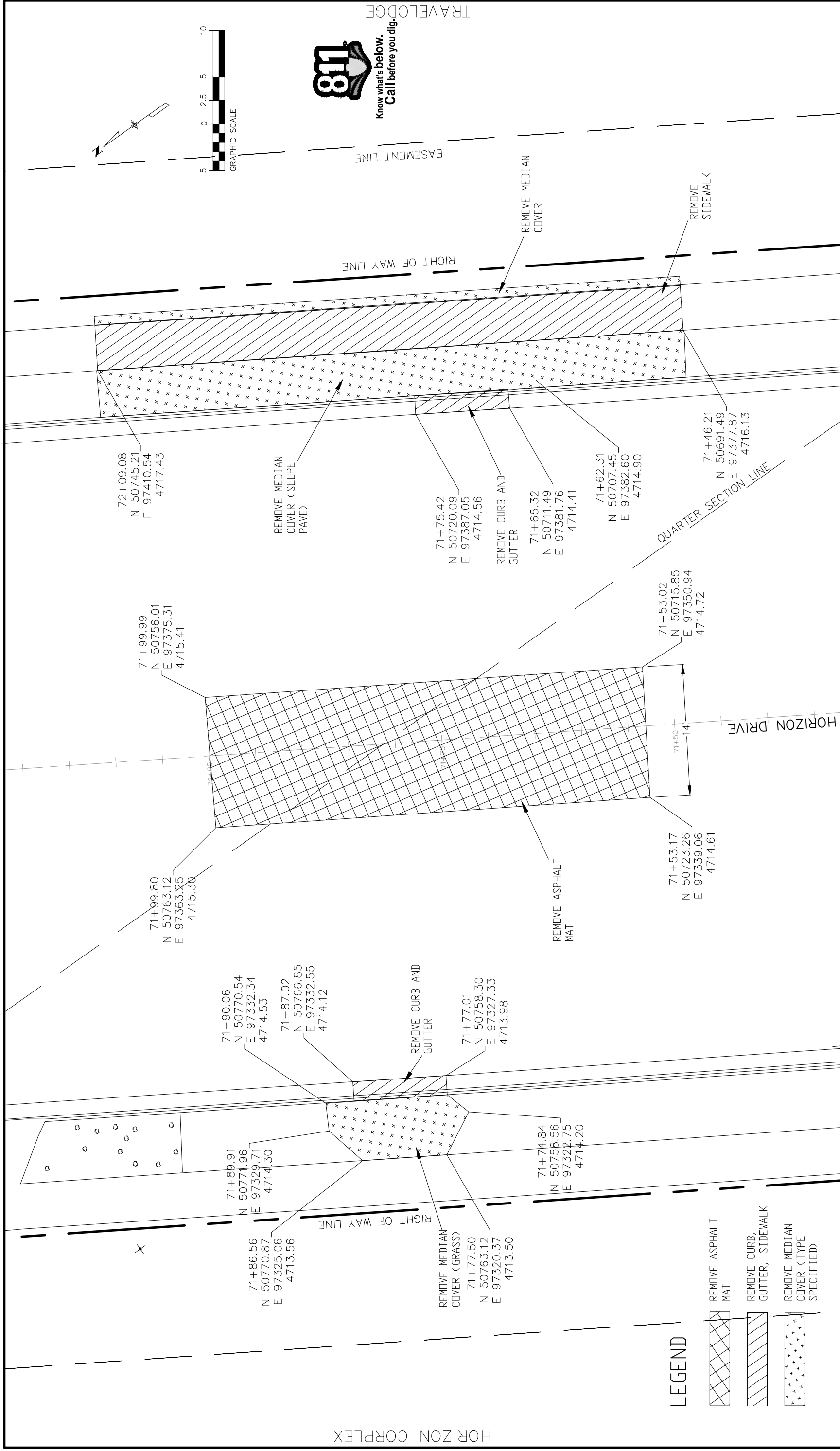
 333 West Ave. Grand Junction, CO, 81501 Phone: 970-244-1554

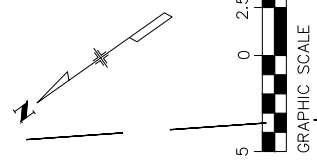

TRAVEL DIRECTION

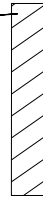
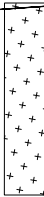

LEGEND

-  REMOVE ASPHALT MAT
-  REMOVE CURB, GUTTER, SIDEWALK
-  REMOVE MEDIAN COVER (TYPE SPECIFIED)

Colorado Department of Transportation

 606 South 9th Street
 Grand Junction, CO, 81501
 Phone: 970-683-6351 FAX: 970-683-6369
 Region 3
 SHY

Sheet Revisions	
Date:	Comments

CITY OF
Grand Junction
 COLORADO

 333 West Ave. Grand Junction, CO, 81501 Phone: 970-244-1554

As Constructed	
No Revisions:	
Revised:	
Void:	

REMOVAL PLAN MIDDLE			
Designer:	JCS	Structure Numbers	
Detailer:	JCS		
Sheet Subset:	General	1 of 1	

Project No./Code	
SHO M555-033	
22497	
Sheet Number	17

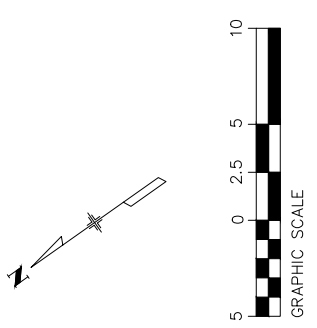
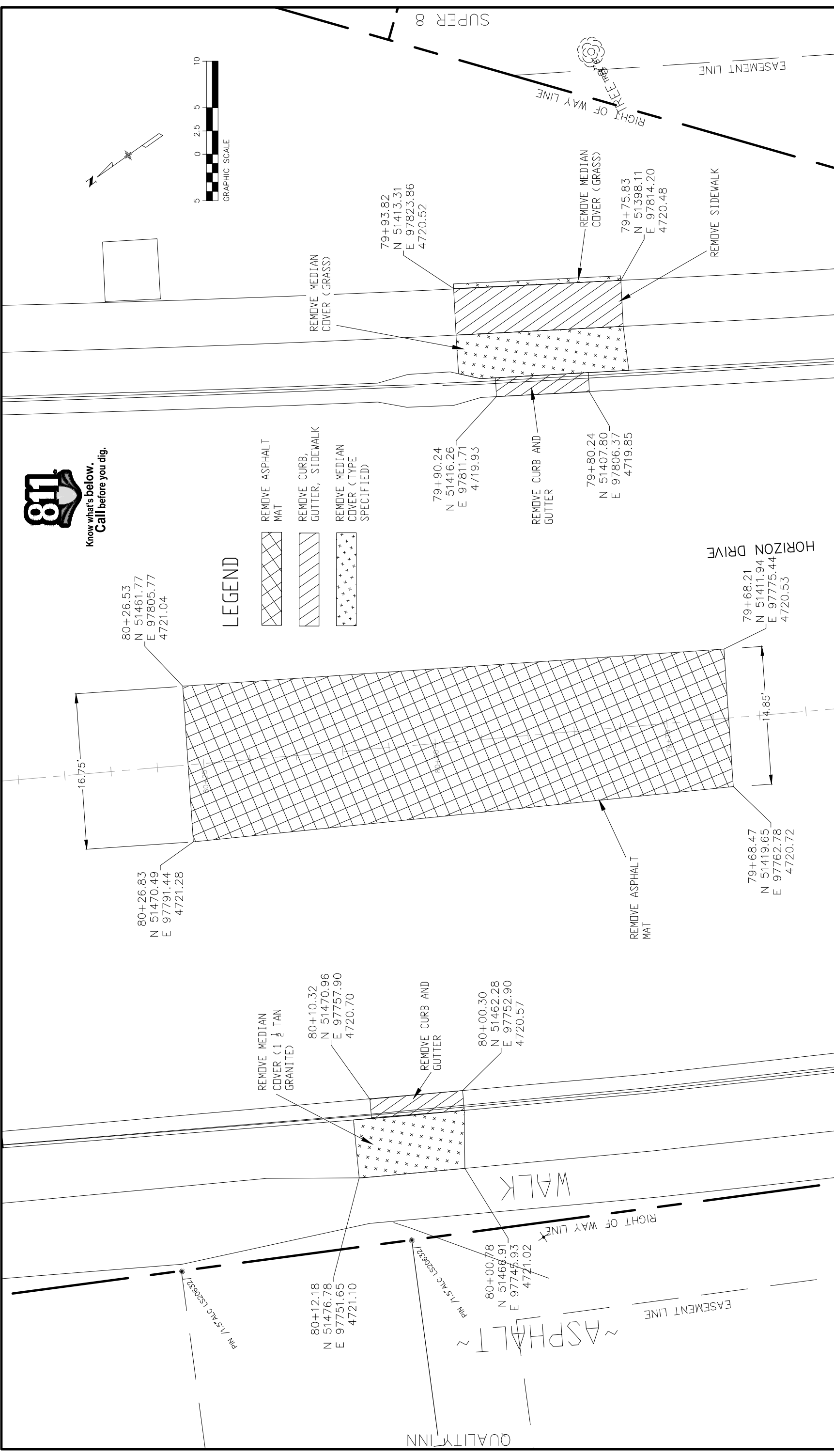

Colorado Department of Transportation 606 South 9th Street Grand Junction, CO, 81501 Phone: 970-683-6351 FAX: 970-683-6369 Region 3	Sheet Revisions Date: _____ Init: _____ Comments: _____ _____ _____		As Constructed No Revisions: _____ Revised: _____ Void: _____		REMOVAL PLAN NORTHERLY Designer: JCS Detailer: JCS Sheet Subset: General Structure Numbers: _____ Subsets: _____		Project No./Code SHO M555-033 22497 18
	CITY OF Grand Junction COLORADO 333 West Ave. Grand Junction, CO, 81501 Phone: 970-244-1554		SHEETS: 1 of 1		SHEET NUMBER: 18		

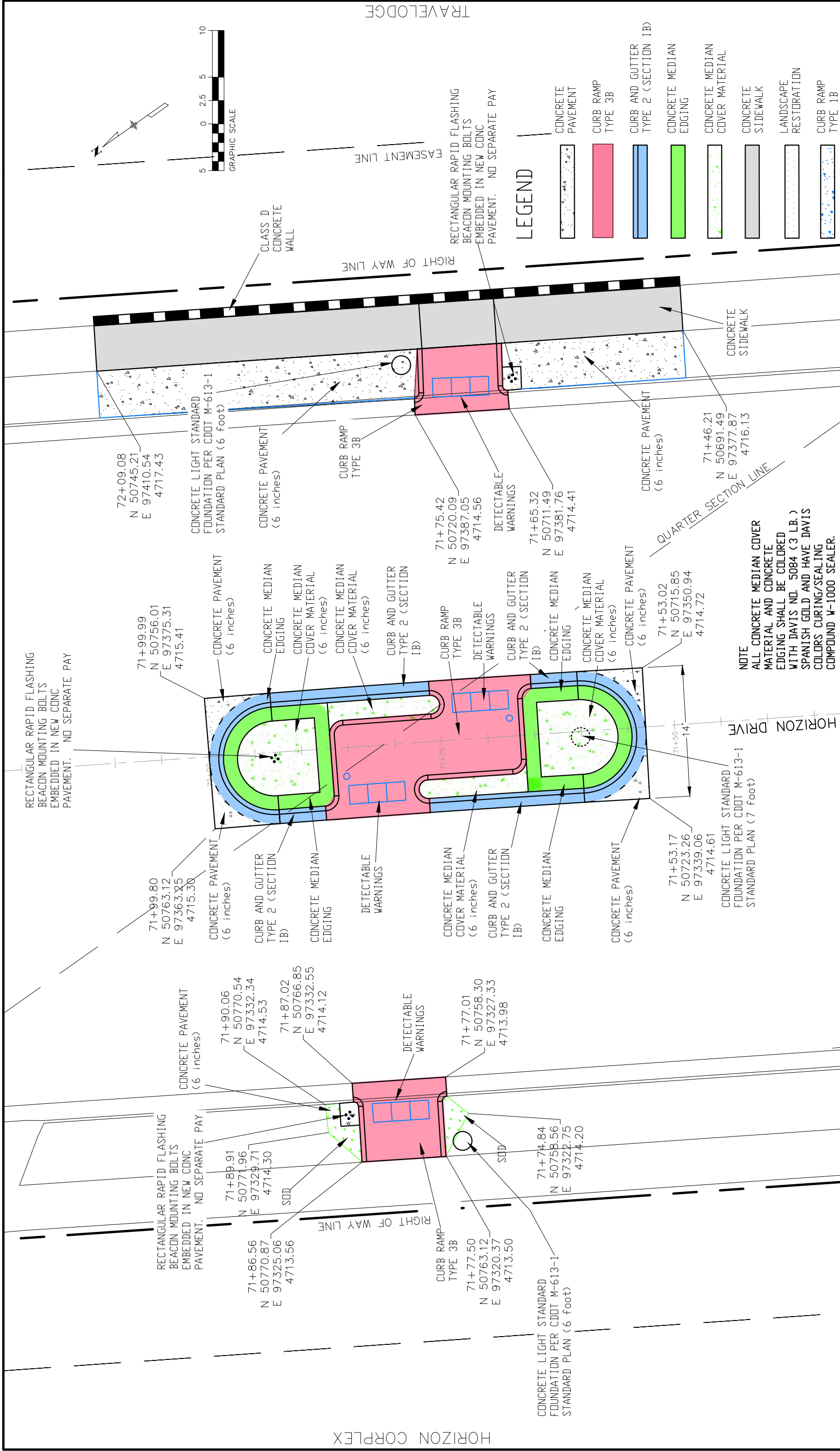

Colorado Department of Transportation 606 South 9th Street Grand Junction, CO, 81501 Phone: 970-683-6351 FAX: 970-683-6369 Region 3	ROADWAY CROSSING PLAN MIDDLE		Project No./Code SHO M555-033
	Sheet Revisions Date: _____ Comments _____ Init. _____	As Constructed No Revisions: Revised: Void:	Designer: JCS Detailer: JCS Sheet Subset: General

UTILITY OWNERS:
 ELECTRIC & GAS
 XCEL ENERGY
 2538 BLICHMAN AVE
 GRAND JUNCTION, CO 81505
 TILLMON MCSCHODLER
 (970)244-2693

TELEPHONE & FIBER OPTIC
 CENTURY LINK
 2524 BLICHMAN AVE
 GRAND JUNCTION, CO 81505
 CHRIS JOHNSON (970)244-4311

CABLE TELEVISION
 CHARTER
 2502 FORESIGHT CIRCLE
 GRAND JUNCTION, CO 81504
 JEFF VALDEZ (970) 263-2314

WATER
 UTE WATER CONSERVANCY DISTRICT
 2190 H 174 ROAD
 GRAND JUNCTION, CO 81505
 DAVE PRISKE (970) 242-7491

TRAFFIC SIGNALS
 CITY OF GRAND JUNCTION
 250 N 5TH STREET
 GRAND JUNCTION, CO 81501
 PAUL JAGIM (970) 244-1542

IRRIGATION
 CITY OF GRAND JUNCTION
 250 N 5TH STREET
 GRAND JUNCTION, CO 81501
 MIKE VENDEGNA (970)254-3843

SANITARY SEWER AND STORM SEWER
 CITY OF GRAND JUNCTION
 250 N 5TH STREET
 GRAND JUNCTION, CO 81501
 LEE COPPER (970) 244-1590

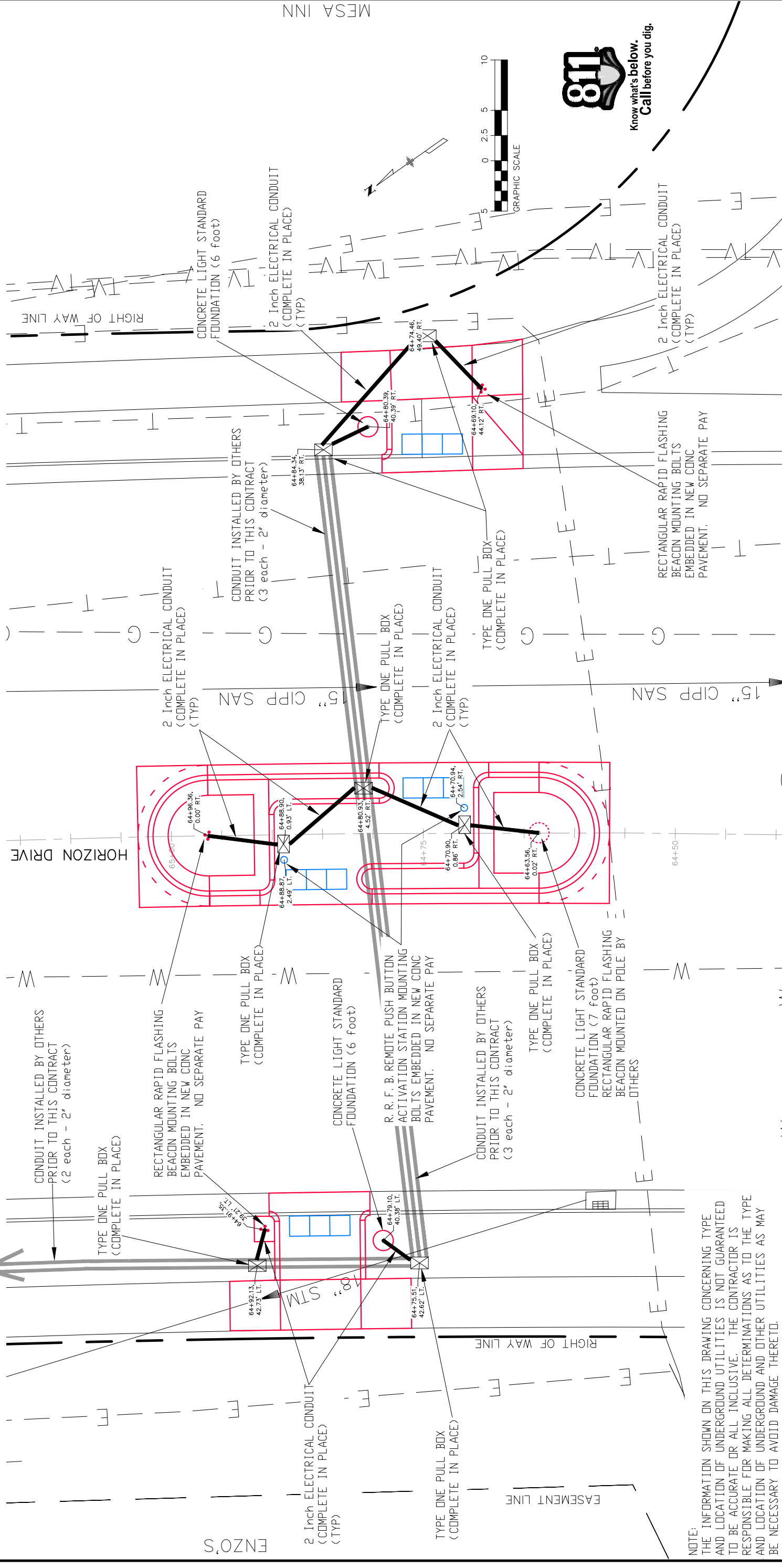

NOTE:
 THE INFORMATION SHOWN ON THIS DRAWING CONCERNING TYPE AND LOCATION OF UNDERGROUND UTILITIES IS NOT GUARANTEED TO BE ACCURATE OR ALL INCLUSIVE. THE CONTRACTOR IS RESPONSIBLE FOR MAKING ALL DETERMINATIONS AS TO THE TYPE AND LOCATION OF UNDERGROUND AND OTHER UTILITIES AS MAY BE NECESSARY TO AVOID DAMAGE THERETO.

Colorado Department of Transportation 606 South 9th Street Grand Junction, CO, 81501 Phone: 970-683-6351 FAX: 970-683-6369 SHY	Sheet Revisions Date: _____ Init: _____ Comments: _____ _____ _____		As Constructed No Revisions: Revised: Void:	UTILITY PLAN SOUTHERLY Designer: JCS Detailer: JCS Sheet Subset: General Subsets: 1 of 1	Project No./Code SHO M555-033 Structure Numbers 22497 Sheet Number 22
	Grand Junction CITY OF COLORADO 333 West Ave. Grand Junction, CO, 81501 Phone: 970-244-1554				

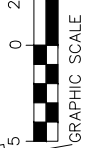

MESA INN

UTILITY OWNERS:

ELECTRIC & GAS
 XCEL ENERGY
 2538 BLICHMAN AVE
 GRAND JUNCTION, CO 81505
 TILLMON MCSCHODLER
 (970)244-2693

TELEPHONE & FIBER OPTIC
 CENTURY LINK
 2524 BLICHMAN AVE
 GRAND JUNCTION, CO 81505
 CHRIS JOHNSON (970)244-4311

CABLE TELEVISION
 CHARTER
 2502 FORESIGHT CIRCLE
 GRAND JUNCTION, CO 81504
 JEFF VALDEZ (970) 263-2314

WATER
 UTE WATER CONSERVANCY DISTRICT
 2190 H 174 ROAD
 GRAND JUNCTION, CO 81505
 DAVE PRISKE (970) 242-7491

TRAFFIC SIGNALS
 CITY OF GRAND JUNCTION
 250 N 5TH STREET
 GRAND JUNCTION, CO 81501
 PAUL JAGIM (970) 244-1542

IRRIGATION
 CITY OF GRAND JUNCTION
 250 N 5TH STREET
 GRAND JUNCTION, CO 81501

SANITARY SEWER AND STORM SEWER
 CITY OF GRAND JUNCTION
 250 N 5TH STREET
 GRAND JUNCTION, CO 81501
 MIKE VENDEGNA (970)254-3843
 LEE COPPER (970) 244-1590

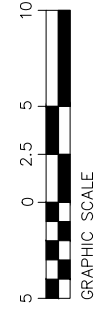
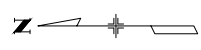
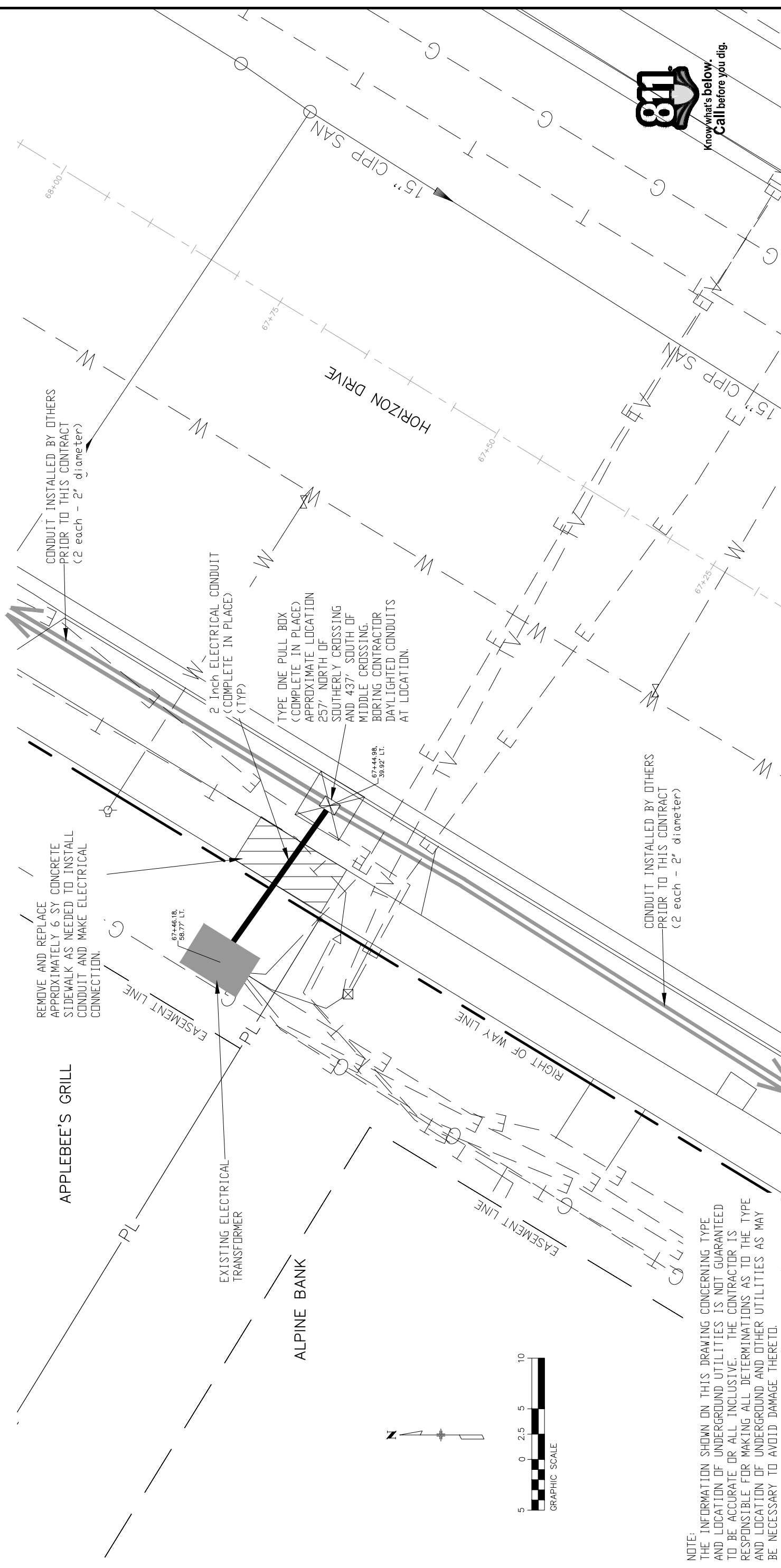

NOTE:
 THE INFORMATION SHOWN ON THIS DRAWING CONCERNING TYPE AND LOCATION OF UNDERGROUND UTILITIES IS NOT GUARANTEED TO BE ACCURATE OR ALL INCLUSIVE. THE CONTRACTOR IS RESPONSIBLE FOR MAKING ALL DETERMINATIONS AS TO THE TYPE AND LOCATION OF UNDERGROUND AND OTHER UTILITIES AS MAY BE NECESSARY TO AVOID DAMAGE THERETO.



Colorado Department of Transportation 606 South 9th Street Grand Junction, CO, 81501 Phone: 970-683-6351 FAX: 970-683-6369 Region 3 SHY	Sheet Revisions		As Constructed		UTILITY PLAN SOUTHERLY		Project No./Code SHO M555-033
	Date:	Comments	Init.	No Revisions:	Designer:	Structure Numbers	22497
				Revised:	Detailer:		Sheet Number
				Void:	Sheet Subset: General	Subst Sheets: 1 of 1	23

CITY OF
Grand Junction
 COLORADO
 333 West Ave. Grand Junction, CO, 81501 Phone: 970-244-1554

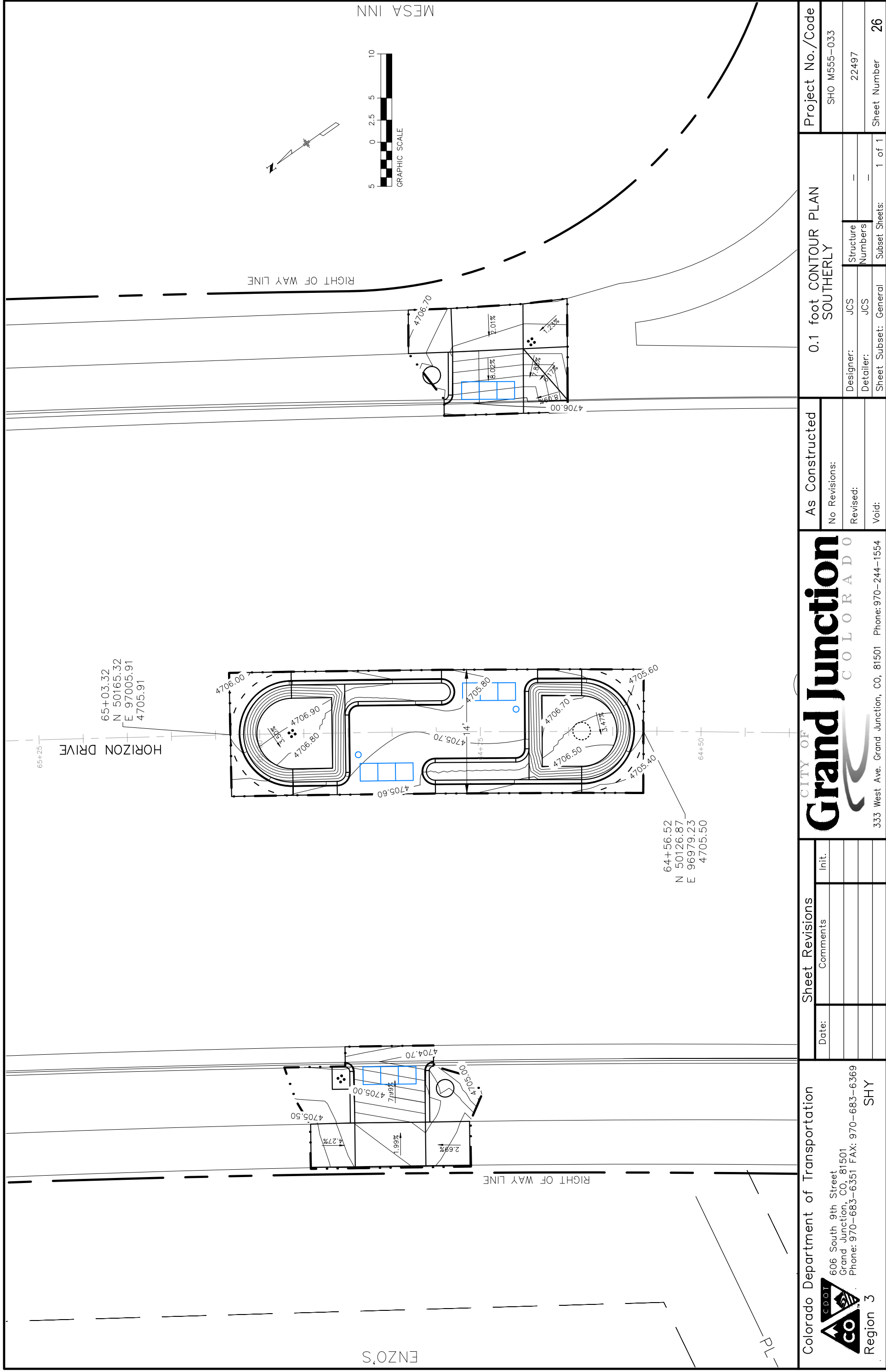

Colorado Department of Transportation



606 South 9th Street
Grand Junction, CO, 81501
Phone: 970-683-6351 FAX: 970-683-6369

Region 3

SHY

Sheet Revisions	
Date:	Comments

CITY OF

Grand Junction

COLORADO



333 West Ave. Grand Junction, CO, 81501 Phone: 970-244-1554

As Constructed	
No Revisions:	
Revised:	
Void:	

0.1 foot CONTOUR PLAN SOUTHERLY		Project No./Code	
Designer:	JCS	SHO M555-033	
Detailer:	JCS	Structure Numbers	22497
Sheet Subset:	General	Sub Set Sheets:	1 of 1
		Sheet Number	26

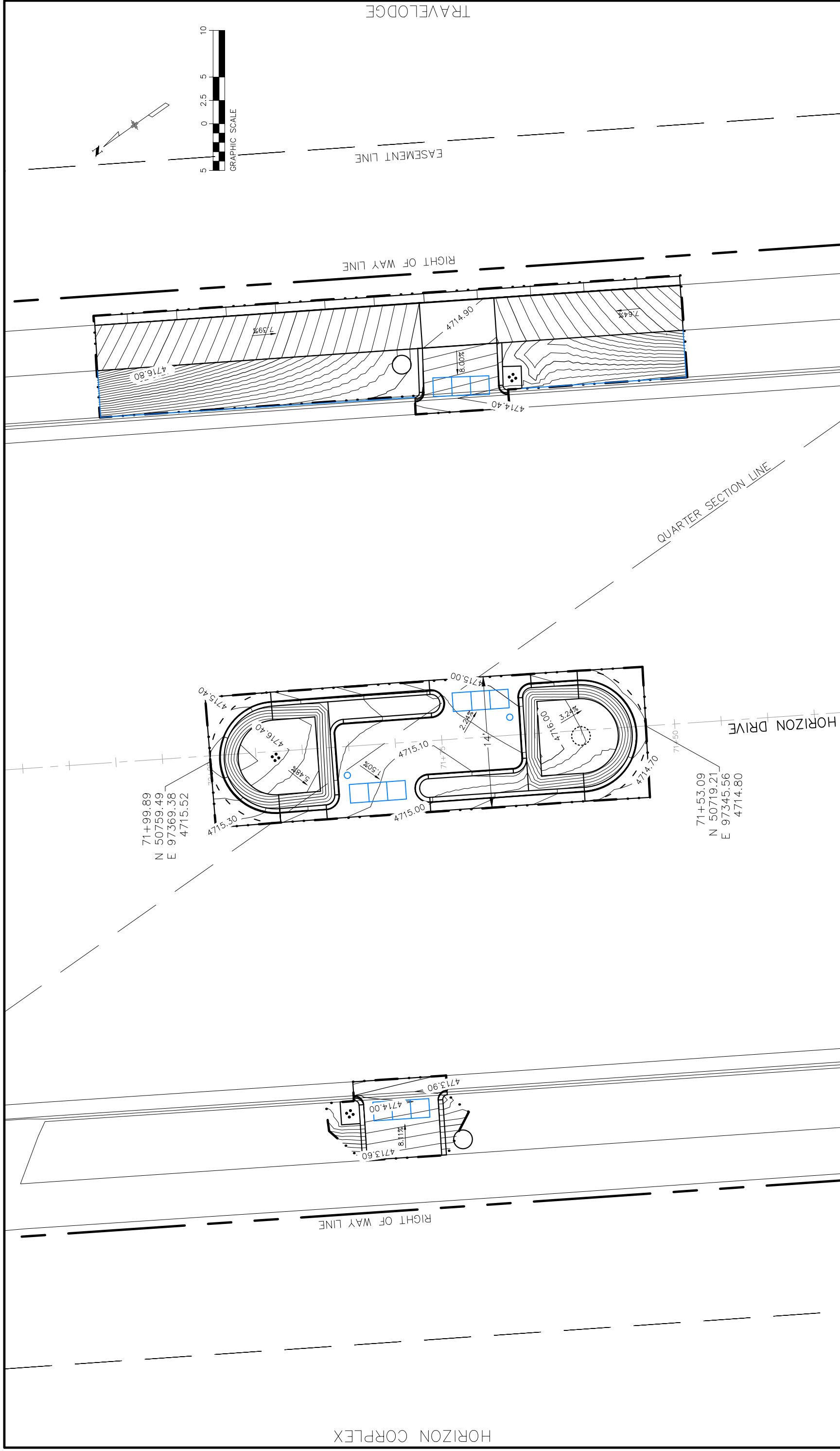

Colorado Department of Transportation 606 South 9th Street Grand Junction, CO, 81501 Phone: 970-683-6351 FAX: 970-683-6369 Region 3	Grand Junction CITY OF COLORADO 333 West Ave. Grand Junction, CO, 81501 Phone: 970-244-1554	As Constructed No Revisions: Revised: Void:	0.1 foot CONTOUR PLAN MIDDLE Designer: JCS Detailer: JCS Sheet Subset: General	Project No./Code SHO M555-033 22497 Sheet Number 27										
	Sheet Revisions <table border="1" style="width: 100%; border-collapse: collapse;"> <thead> <tr> <th style="width: 10%;">Date:</th> <th style="width: 80%;">Comments</th> <th style="width: 10%;">Init.</th> </tr> </thead> <tbody> <tr> <td> </td> <td> </td> <td> </td> </tr> <tr> <td> </td> <td> </td> <td> </td> </tr> <tr> <td> </td> <td> </td> <td> </td> </tr> </tbody> </table>	Date:	Comments	Init.										Designer: JCS Detailer: JCS Sheet Subset: General
Date:	Comments	Init.												

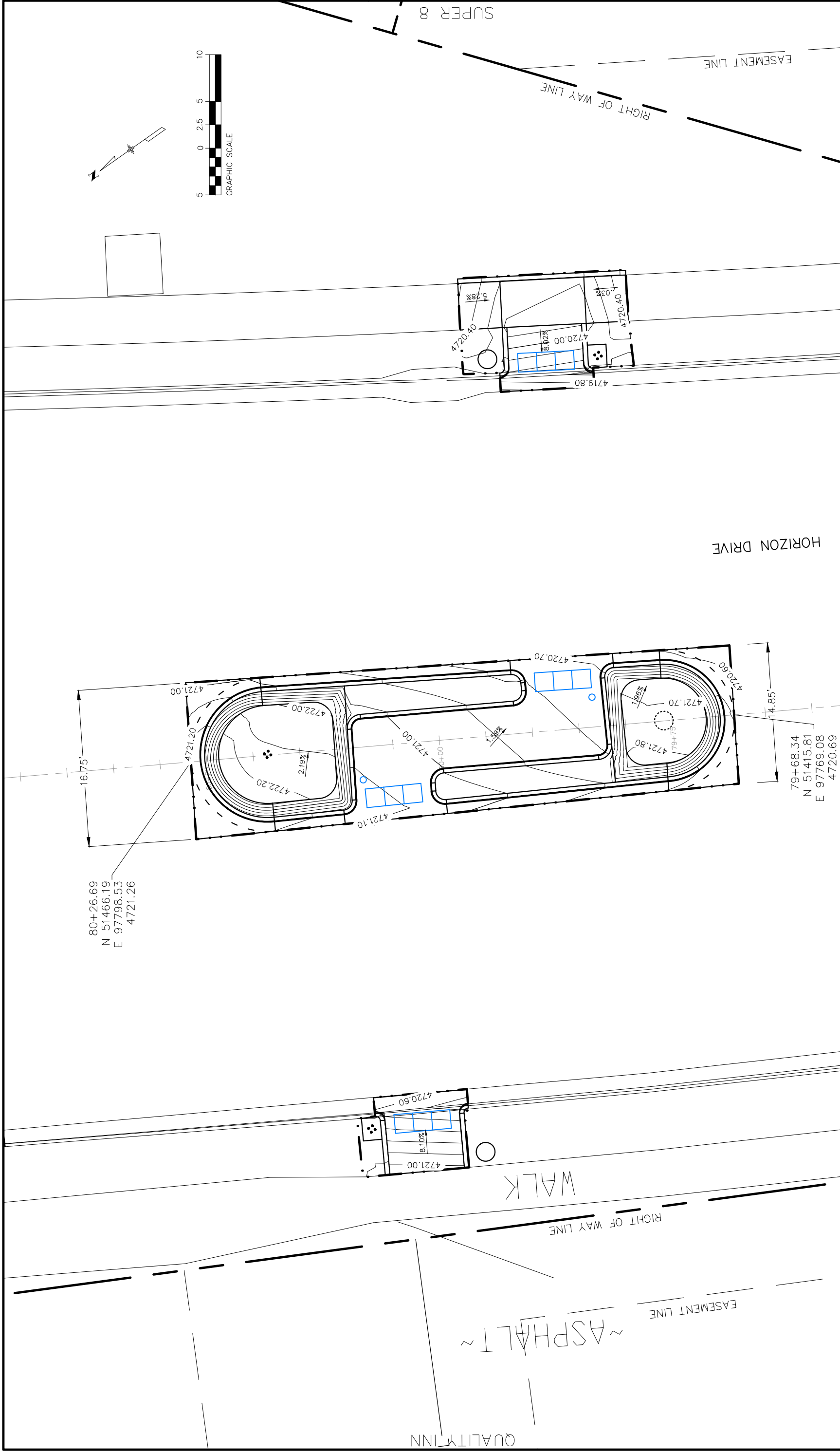

Colorado Department of Transportation 606 South 9th Street Grand Junction, CO, 81501 Phone: 970-683-6351 FAX: 970-683-6369 Region 3	Sheet Revisions <table border="1" style="width: 100%; border-collapse: collapse;"> <thead> <tr> <th style="width: 10%;">Date:</th> <th style="width: 70%;">Comments</th> <th style="width: 20%;">Init.</th> </tr> </thead> <tbody> <tr><td> </td><td> </td><td> </td></tr> <tr><td> </td><td> </td><td> </td></tr> <tr><td> </td><td> </td><td> </td></tr> </tbody> </table>	Date:	Comments	Init.										As Constructed No Revisions: Revised: Void:	0.1 foot CONTOUR PLAN NORTHERLY Designer: JCS Detailer: JCS Sheet Subset: General Structure Numbers: -- Subset Sheets: 1 of 1	Project No./Code SHO M555-033 22497 Sheet Number 28
	Date:	Comments	Init.													
CITY OF <h1 style="margin: 0;">Grand Junction</h1> COLORADO 333 West Ave. Grand Junction, CO, 81501 Phone: 970-244-1554																

STATION	SIDE DIMENSIONS	SIGN CODE / REF NO	LEGEND	(614-00011) SIGN PANEL (CLASS I)		(614-80003) RAPID RECTANGULAR FLASHING BEACON SYSTEM		(614-00200) STEEL SIGN POST (U-2)		NOTES
				Plan	As Const	Plan	As Const	Plan	As Const	
HORIZON										
64+91.35	LT 36X 36	R1-5	YIELD HERE TO PEDS	9.00				1		SOUTH CROSSING ON THE WEST SIDE OF THE ROAD MOUNTED ON RRFB ASSY POLE
64+91.35	LT 30X 30	W11-2	PEDESTRIAN	6.25						MOUNTED ON RRFB ASSY POLE
64+91.35	LT 24X 12	W16-7PL	DOWNWARD DIAGONAL ARROW LEFT	8.00						MOUNTED ON RRFB ASSY POLE
64+91.35	LT 9X 12	R10-25	PUSH BUTTON TO TURN ON WARNING LIGHTS	0.75						MOUNTED ON RRFB ASSY POLE
64+96.36 TO 64+96.36		614-80003	RAPID RECTANGULAR FLASHING BEACON SYSTEM (COMPLETE IN PLACE)		1.00					SOUTH CROSSING RRFB SYSTEM (INCLUDES ALL NECESSARY POLES, WIRES, PUSH BUTTONS, & APPURTENANCES PER PLAN)
64+63.56	CL 30X 30	W11-2	PEDESTRIAN	6.25						MOUNTED ON STREET LIGHT POLE
64+63.56	CL 24X 12	W16-7PR	DOWNWARD DIAGONAL ARROW RIGHT	8.00						MOUNTED ON STREET LIGHT POLE
64+70.94	RT 9X 12	R10-25	PUSH BUTTON TO TURN ON WARNING LIGHTS	0.75						MOUNTED ON REMOTE PUSH BUTTON POLE
64+88.87	LT 9X 12	R10-25	PUSH BUTTON TO TURN ON WARNING LIGHTS	0.75						MOUNTED ON REMOTE PUSH BUTTON POLE
64+96.36	CL 30X 30	W11-2	PEDESTRIAN	6.25						MOUNTED ON RRFB ASSY POLE
64+96.36	CL 24X 12	W16-7PR	DOWNWARD DIAGONAL ARROW RIGHT	8.00						MOUNTED ON RRFB ASSY POLE
64+36.12	RT 36X 36	R1-5	YIELD HERE TO PEDS	9.00				1		SOUTH CROSSING ON THE EAST SIDE OF THE ROAD MOUNTED ON RRFB ASSY POLE
64+69.10	RT 30X 30	W11-2	PEDESTRIAN	6.25						MOUNTED ON RRFB ASSY POLE
64+69.10	RT 24X 12	W16-7PL	DOWNWARD DIAGONAL ARROW LEFT	8.00						MOUNTED ON RRFB ASSY POLE
64+69.10	RT 9X 12	R10-25	PUSH BUTTON TO TURN ON WARNING LIGHTS	0.75						MOUNTED ON RRFB ASSY POLE
72+19.93	LT 36X 36	R1-5	YIELD HERE TO PEDS	9.00				1		MIDDLE CROSSING ON THE WEST SIDE OF THE ROAD MOUNTED ON RRFB ASSY POLE
71+87.59	LT 30X 30	W11-2	PEDESTRIAN	6.25						MOUNTED ON RRFB ASSY POLE
71+87.59	LT 24X 12	W16-7PL	DOWNWARD DIAGONAL ARROW LEFT	8.00						MOUNTED ON RRFB ASSY POLE
71+87.59	LT 9X 12	R10-25	PUSH BUTTON TO TURN ON WARNING LIGHTS	0.75						MOUNTED ON RRFB ASSY POLE
71+92.93	CL 30X 30	W11-2	PEDESTRIAN	6.25						MOUNTED ON RRFB ASSY POLE
71+92.93	CL 24X 12	W16-7PR	DOWNWARD DIAGONAL ARROW RIGHT	8.00						MOUNTED ON RRFB ASSY POLE
71+31.60	RT 36X 36	R1-5	YIELD HERE TO PEDS	9.00				1		MIDDLE CROSSING ON THE EAST SIDE OF THE ROAD MOUNTED ON RRFB ASSY POLE
71+64.85	RT 30X 30	W11-2	PEDESTRIAN	6.25						MOUNTED ON RRFB ASSY POLE
71+64.85	RT 24X 12	W16-7PL	DOWNWARD DIAGONAL ARROW LEFT	8.00						MOUNTED ON RRFB ASSY POLE
71+64.85	RT 9X 12	R10-25	PUSH BUTTON TO TURN ON WARNING LIGHTS	0.75						MOUNTED ON RRFB ASSY POLE
80+43.38	LT 36X 36	R1-5	YIELD HERE TO PEDS	9.00				1		NORTH CROSSING ON THE WEST SIDE OF THE ROAD MOUNTED ON RRFB ASSY POLE
80+10.81	LT 30X 30	W11-2	PEDESTRIAN	6.25						MOUNTED ON RRFB ASSY POLE
80+10.81	LT 24X 12	W16-7PL	DOWNWARD DIAGONAL ARROW LEFT	8.00						MOUNTED ON RRFB ASSY POLE
80+10.81	LT 9X 12	R10-25	PUSH BUTTON TO TURN ON WARNING LIGHTS	0.75						MOUNTED ON RRFB ASSY POLE
79+75.88 TO 80+18.40		614-80003	RAPID RECTANGULAR FLASHING BEACON SYSTEM (COMPLETE IN PLACE)		1.00					SOUTH CROSSING RRFB SYSTEM (INCLUDES ALL NECESSARY POLES, WIRES, PUSH BUTTONS, & APPURTENANCES PER PLAN)
79+75.88	CL 30X 30	W11-2	PEDESTRIAN	6.25						MOUNTED ON STREET LIGHT POLE
79+75.88	CL 24X 12	W16-7PR	DOWNWARD DIAGONAL ARROW RIGHT	8.00						MOUNTED ON STREET LIGHT POLE
79+83.33	RT 9X 12	R10-25	PUSH BUTTON TO TURN ON WARNING LIGHTS	0.75						MOUNTED ON REMOTE PUSH BUTTON POLE
80+08.48	LT 9X 12	R10-25	PUSH BUTTON TO TURN ON WARNING LIGHTS	0.75						MOUNTED ON REMOTE PUSH BUTTON POLE
80+18.40	CL 30X 30	W11-2	PEDESTRIAN	6.25						MOUNTED ON RRFB ASSY POLE
80+18.40	CL 24X 12	W16-7PR	DOWNWARD DIAGONAL ARROW RIGHT	8.00						MOUNTED ON RRFB ASSY POLE
79+47.36	RT 36X 36	R1-5	YIELD HERE TO PEDS	9.00				1		NORTH CROSSING ON THE EAST SIDE OF THE ROAD MOUNTED ON RRFB ASSY POLE
79+79.54	RT 30X 30	W11-2	PEDESTRIAN	6.25						MOUNTED ON RRFB ASSY POLE
79+79.54	RT 24X 12	W16-7PL	DOWNWARD DIAGONAL ARROW LEFT	8.00						MOUNTED ON RRFB ASSY POLE
79+79.54	RT 9X 12	R10-25	PUSH BUTTON TO TURN ON WARNING LIGHTS	0.75						MOUNTED ON RRFB ASSY POLE
				TOTAL =		234	3	6		

Project No./Code
SHO M555-033

TABULATION OF SIGNALS & FINAL SIGNING
Designer: JCS
Detailer: JCS
Structure Numbers: --
Sheet Subset: TAB
Sheet Number: 29
1 of 1
Subset Sheets:

As Constructed
No Revisions:
Revised:
Void:

CITY OF
Grand Junction
C O L O R A D O
333 West Ave. Grand Junction, CO, 81501 Phone: 970-244-1554

Sheet Revisions

Date:	Comments	Init.

Colorado Department of Transportation
606 South 9th Street
Grand Junction, CO, 81501
Phone: 970-683-6351 FAX: 970-683-6369
SHY
Region 3

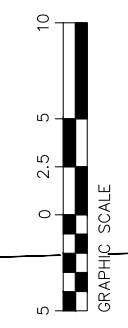
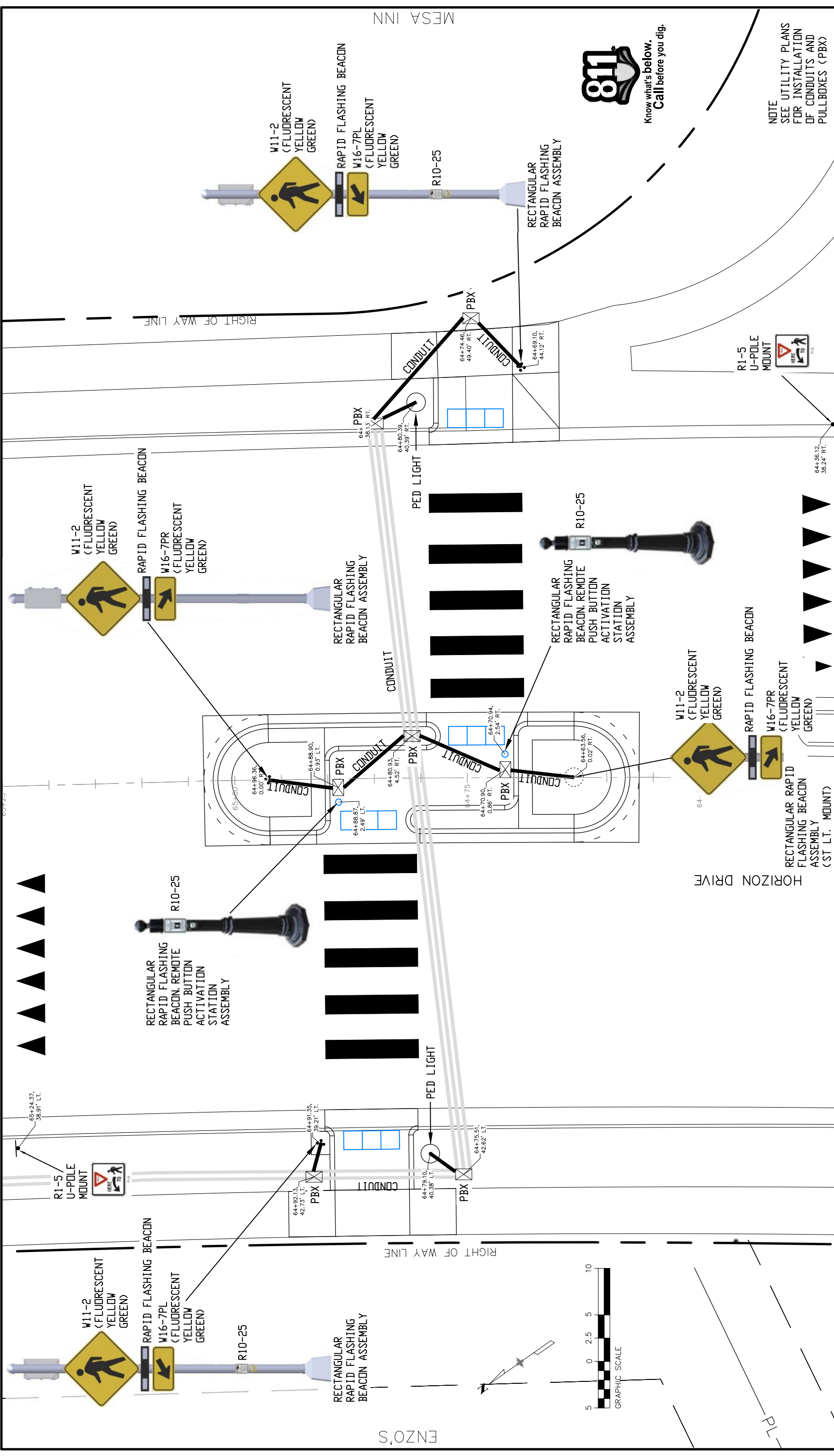

Colorado Department of Transportation

 606 South 9th Street
 Grand Junction, CO, 81501
 Phone: 970-683-6351 FAX: 970-683-6369
 SHY
 Region 3

Sheet Revisions	
Date:	Comments

CITY OF
Grand Junction
 COLORADO
 333 West Ave. Grand Junction, CO, 81501 Phone: 970-244-1554

As Constructed	
No Revisions:	
Revised:	
Void:	

SIGNAL AND SIGNING PLAN SOUTHERLY	
Project No./Code	
Designer:	JCS
Detailer:	JCS
Structure Numbers	
Sheet Subset: General	1 of 1
Sheet Number	30



NOTE
 SEE UTILITY PLANS
 FOR INSTALLATION
 OF CONDUITS AND
 PULLBOXES (PBX)

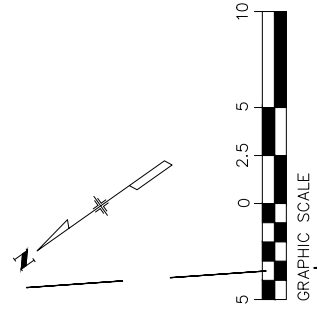
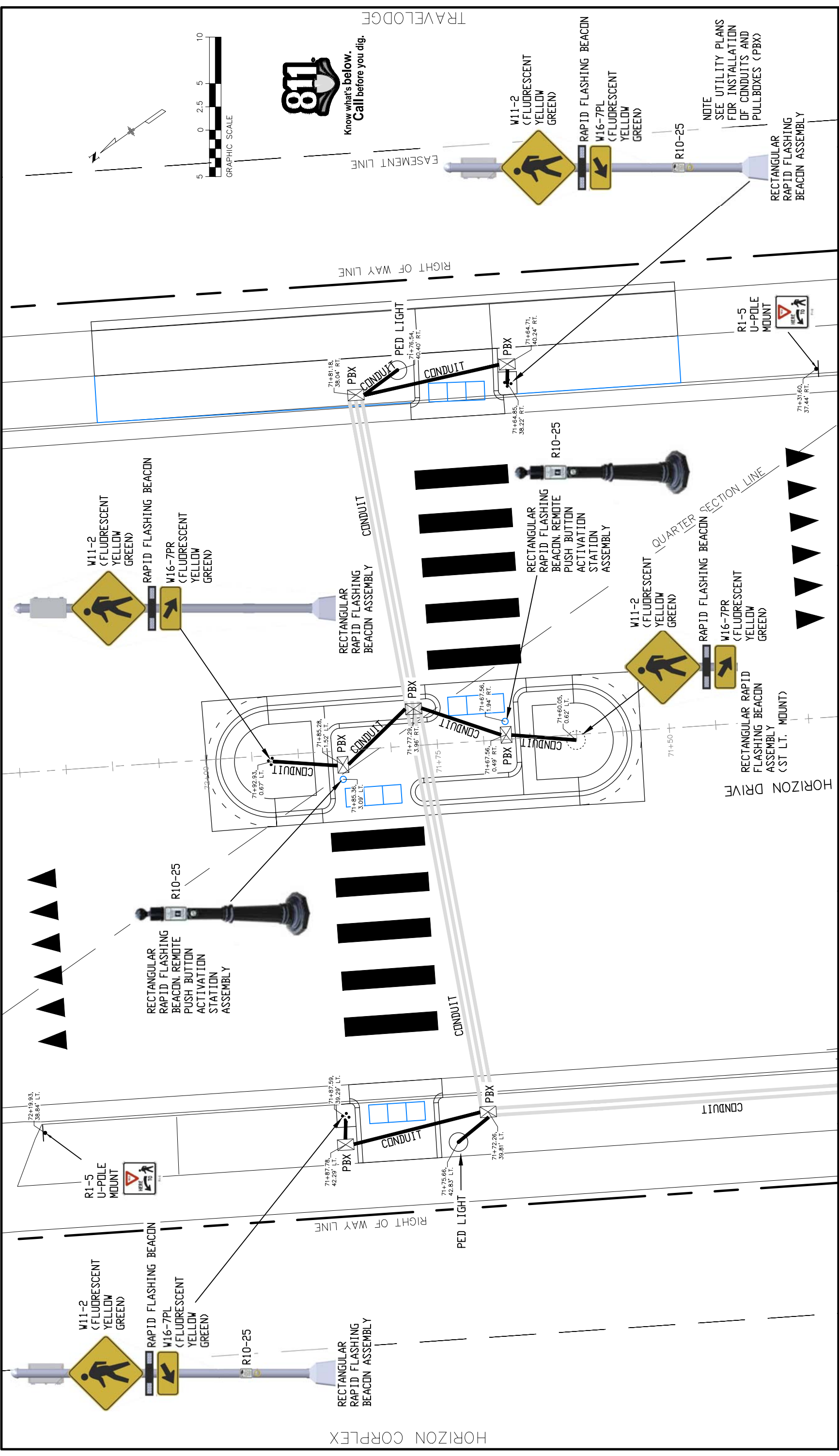

Colorado Department of Transportation  606 South 9th Street Grand Junction, CO, 81501 Phone: 970-683-6351 FAX: 970-683-6369 Region 3	Sheet Revisions Date: _____ Comments _____ Init. _____		CITY OF Grand Junction COLORADO 333 West Ave. Grand Junction, CO, 81501 Phone: 970-244-1554	As Constructed No Revisions: Revised: Void:	SIGNAL AND SIGNING PLAN MIDDLE	Project No./Code SHO M555-033
	Designer: JCS Detailer: JCS	Structure Numbers Subset Sheets: 1 of 1				

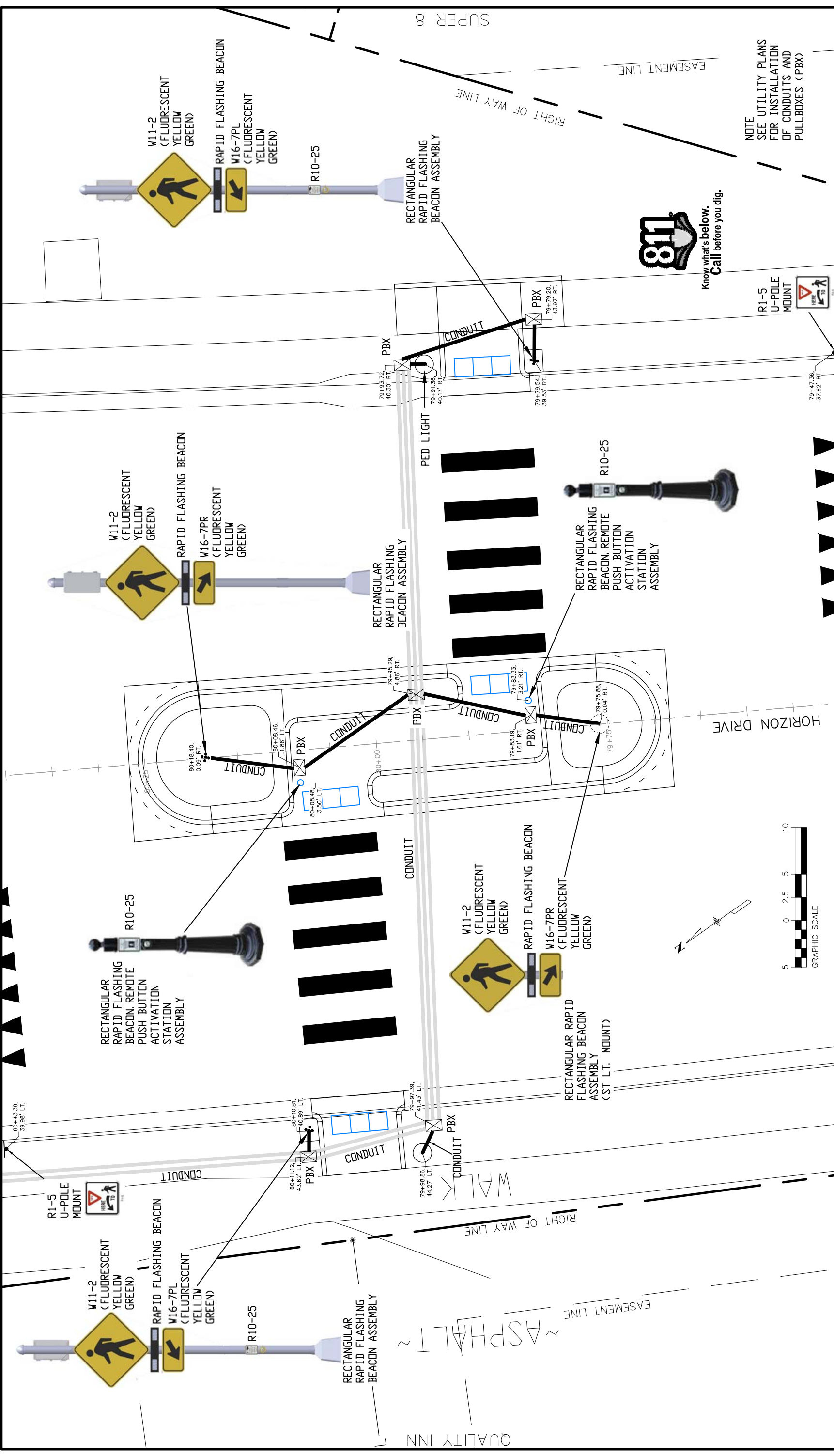

NOTE
SEE UTILITY PLANS
FOR INSTALLATION
OF CONDUITS AND
PULLBOXES (PBX)

 Colorado Department of Transportation 606 South 9th Street Grand Junction, CO, 81501 Phone: 970-683-6351 FAX: 970-683-6369 Region 3	Sheet Revisions Date: _____ Init: _____ Comments: _____		As Constructed No Revisions: _____ Revised: _____ Void: _____		SIGNAL AND SIGNING PLAN NORTHERLY		Project No./Code SHO M555-033	
	SHEET NO. 32		SHEET NO. 32		Designer: JCS Detailer: JCS Sheet Subset: General		Structure Numbers: 22497 Subset Sheets: 1 of 1 Sheet Number: 32	

Grand Junction
 COLORADO
 333 West Ave. Grand Junction, CO, 81501 Phone: 970-244-1554

LOCATION	DESCRIPTION	COMMENTS	(627-30410) PERFORMED THERMOPLASTIC PAVEMENT MARKING (XWALK-STOP LINE)	
			LF	SF
HORIZON DRIVE				
64+38.98, 11.10' RT TO 64+39.31, 30.53' RT 64+73.98, 8.65' RT TO 64+73.93, 30.58' RT	YIELD LINE "SHARKS TEETH" (24" BASE, 36" HEIGHT) CROSSWALK	SOUTH CROSSING NW BOUND LANES SOUTH CROSSING NW BOUND LANES	20 50	18 100
65+21.19, 28.97' LT TO 65+20.71, 9.53' LT 64+86.00, 30.11' LT TO 64+85.56, 8.18' LT	YIELD LINE "SHARKS TEETH" (24" BASE, 36" HEIGHT) CROSSWALK	SOUTH CROSSING SE BOUND LANES SOUTH CROSSING SE BOUND LANES	20 50	18 100
71+35.57, 9.71' RT TO 71+35.46, 29.16' RT 71+70.06, 8.02' RT TO 71+70.36, 29.46' RT	YIELD LINE "SHARKS TEETH" (24" BASE, 36" HEIGHT) CROSSWALK	MIDDLE CROSSING NW BOUND LANES MIDDLE CROSSING NW BOUND LANES	20 50	18 100
72+16.99, 30' LT TO 72+16.93, 10.56' LT 71+81.95, 30.69' LT TO 71+81.72, 8.75' LT	YIELD LINE "SHARKS TEETH" (24" BASE, 36" HEIGHT) CROSSWALK	MIDDLE CROSSING SE BOUND LANES MIDDLE CROSSING SE BOUND LANES	20 50	18 100
79+50.87, 9.39' RT TO 79+50.33, 28.83' RT 79+86.09, 8.39' RT TO 79+85.19, 30.31' RT	YIELD LINE "SHARKS TEETH" (24" BASE, 36" HEIGHT) CROSSWALK	NORTH CROSSING NW BOUND LANES NORTH CROSSING NW BOUND LANES	20 50	18 100
80+40.58, 31.38' LT TO 80+40.87, 11.96' LT 80+05.47, 31.52' LT TO 80+05.75, 9.55' LT	YIELD LINE "SHARKS TEETH" (24" BASE, 36" HEIGHT) CROSSWALK	NORTH CROSSING SE BOUND LANES NORTH CROSSING SE BOUND LANES	20 50	18 100
TOTAL LF			420	
TOTAL SF				708

<p>Colorado Department of Transportation</p> <p>606 South 9th Street Grand Junction, CO, 81501 Phone: 970-683-6351 FAX: 970-683-6369</p> <p style="text-align: right;">SHY</p> <p>Region 3</p>	<p style="text-align: center;">Grand Junction CITY OF C O L O R A D O</p> <p style="font-size: small;">333 West Ave. Grand Junction, CO, 81501 Phone: 970-244-1554</p>	<p style="text-align: center;">TABULATION OF STRIPING</p> <p>As Constructed</p> <p>No Revisions:</p> <p>Revised:</p> <p>Void:</p>	<p>Project No./Code</p> <p>SHO M555-033</p> <p>22497</p> <p>Sheet Number 33</p>								
<p>Sheet Revisions</p> <table border="1" style="width: 100%; border-collapse: collapse;"> <thead> <tr> <th style="width: 80%;">Date:</th> <th style="width: 20%;">Init.</th> </tr> </thead> <tbody> <tr> <td> </td> <td> </td> </tr> <tr> <td> </td> <td> </td> </tr> <tr> <td> </td> <td> </td> </tr> </tbody> </table>		Date:	Init.							<p>Design: JCS</p> <p>Detailer: JCS</p> <p>Sheet Subset: TAB</p> <p>Structure Numbers: -</p> <p>Subset Sheets: 1 of 1</p>	
Date:	Init.										

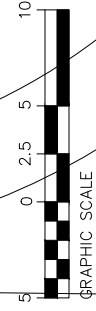
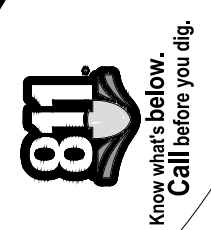
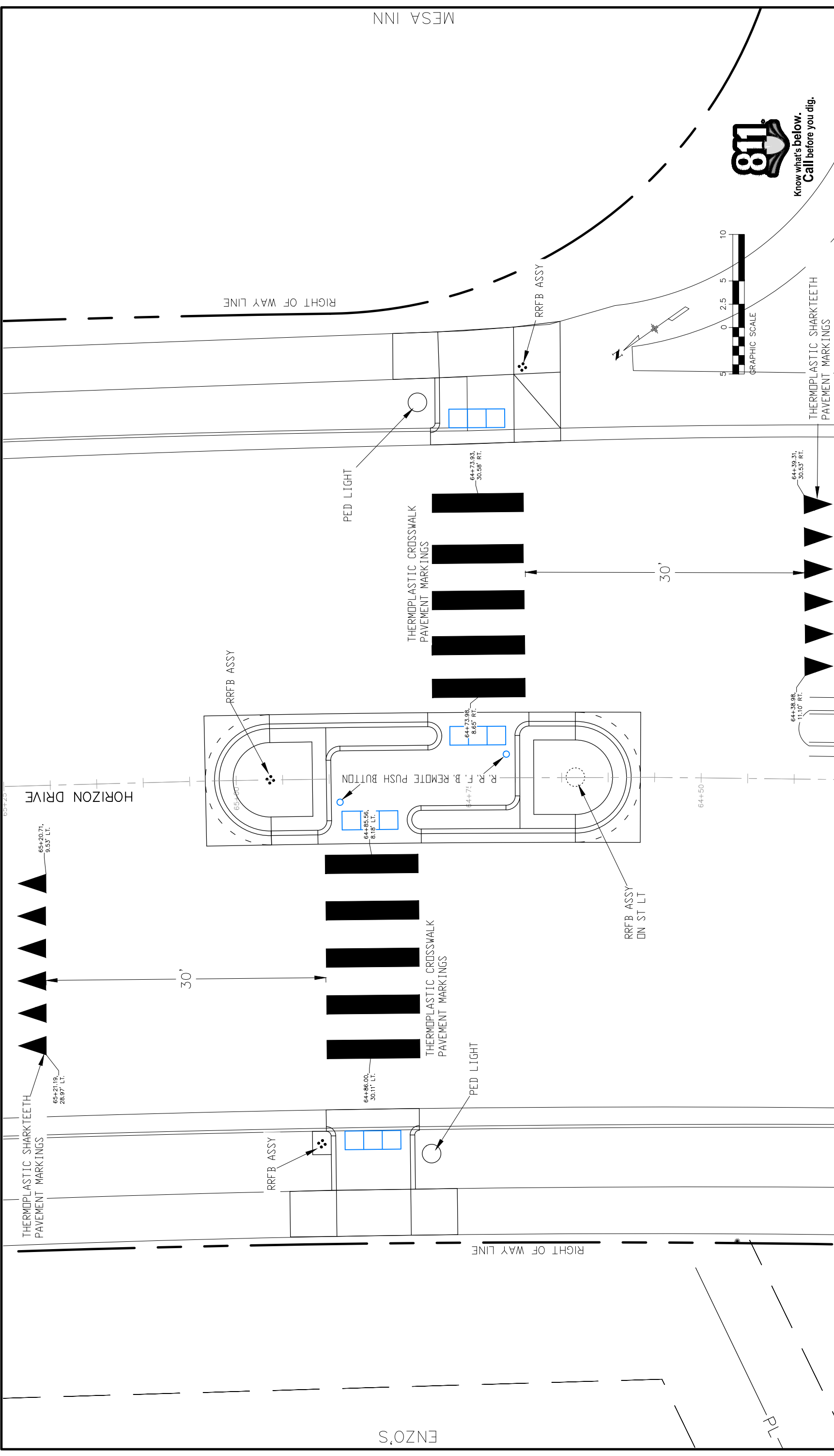

Colorado Department of Transportation 606 South 9th Street Grand Junction, CO, 81501 Phone: 970-683-6351 FAX: 970-683-6369 Region 3	Sheet Revisions Date: _____ Init: _____ Comments: _____ _____ _____		As Constructed No Revisions: Revised: Void:		STRIPING PLAN SOUTHERLY		Project No./Code SHO M555-033
	CITY OF Grand Junction COLORADO 333 West Ave. Grand Junction, CO, 81501 Phone: 970-244-1554		Designer: JCS Detailer: JCS Sheet Subset: General		Structure Numbers: - Subset Sheets: 1 of 1		22497 Sheet Number 34

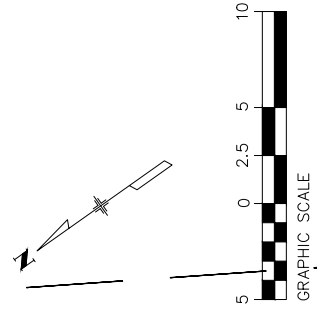
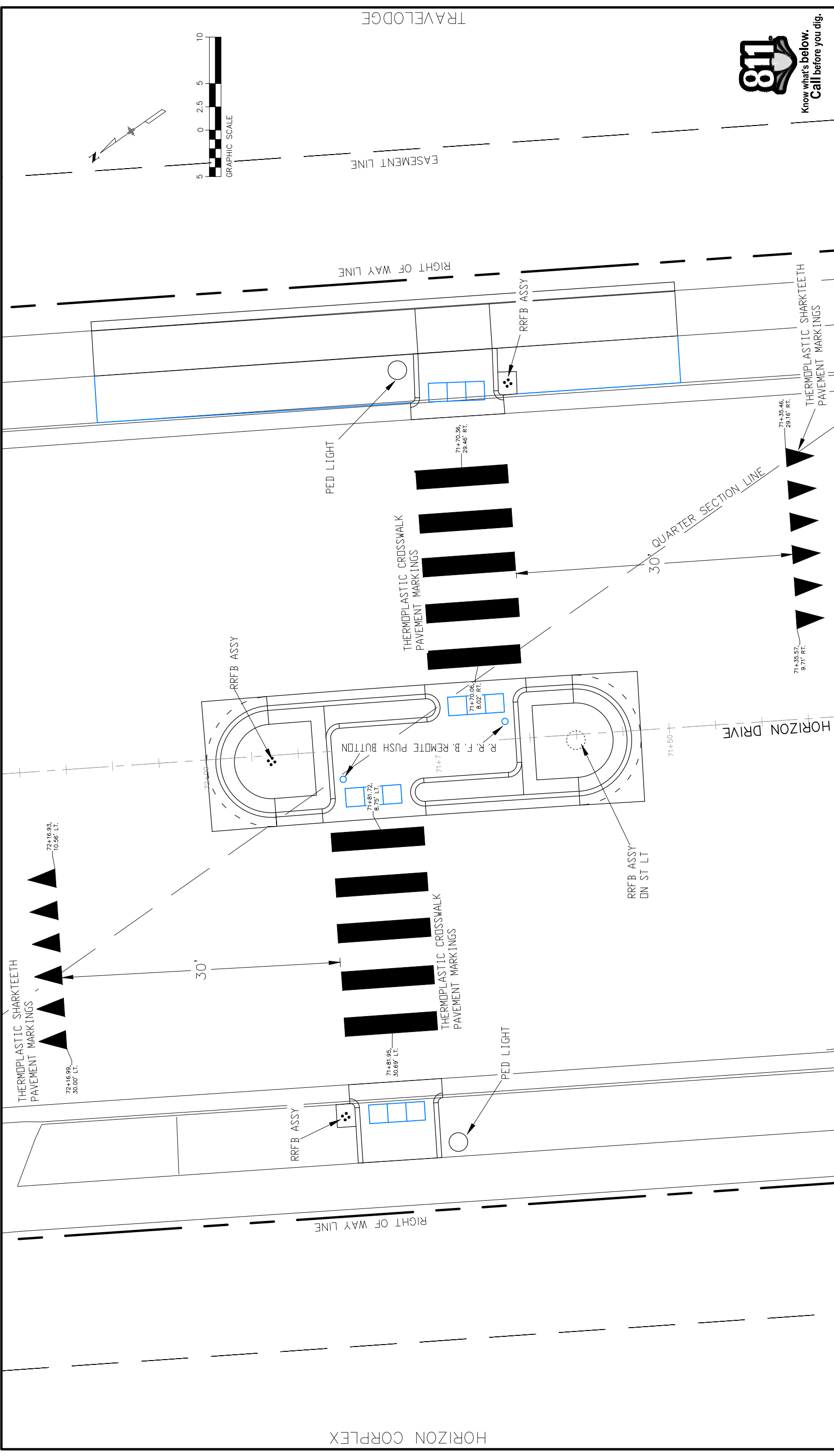

Project No./Code	SHO M555-033
Designer:	JCS
Detailer:	JCS
Structure Numbers	-
Sheet Subset:	General
Sheet Number	35

As Constructed	No Revisions:	0
Revised:	Void:	0

Sheet Revisions	Date:	Comments	Init.

CITY OF Grand Junction
 COLORADO
 333 West Ave. Grand Junction, CO, 81501 Phone: 970-244-1554

Colorado Department of Transportation	606 South 9th Street Grand Junction, CO, 81501 Phone: 970-683-6351 FAX: 970-683-6369
Region 3	SHY

STRIPING PLAN	MIDDLE
---------------	--------

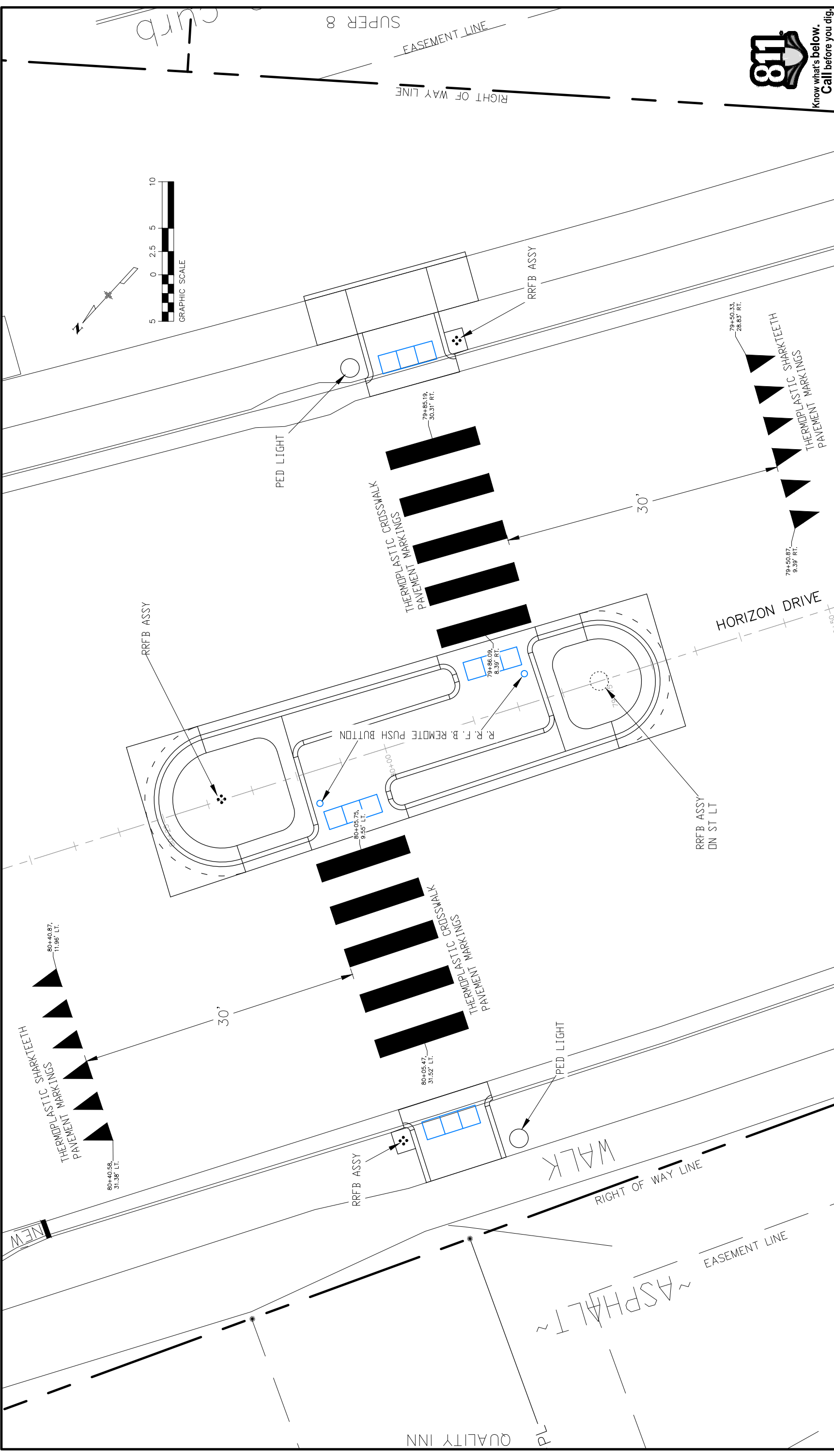

Project No./Code	SHO M555-033
Designer:	JCS
Detailer:	JCS
Structure Numbers	-
Sheet Subset:	General
Sheet Number	36

As Constructed	No Revisions:	0
Revised:	Void:	0

STRIPING PLAN	1 of 1
NORTHERLY	1 of 1

CITY OF Grand Junction COLORADO
 333 West Ave. Grand Junction, CO, 81501 Phone: 970-244-1554

Date:	Comments	Init.

Colorado Department of Transportation
 606 South 9th Street
 Grand Junction, CO, 81501
 Phone: 970-683-6351 FAX: 970-683-6369
 SHY
 Region 3

SWMP TEMPLATE TEXT FOR PROJECTS WITH LESS THAN 1 ACRE OF DISTURBANCE

THE CONTRACTOR SHALL PERFORM THE FOLLOWING:

1. SITE DESCRIPTION

- A. **PROJECT SITE LOCATION:** Grand Junction Horizon Drive Crosswalks are located in Grand Junction, Mesa County, Colorado. The project lies along Horizon Drive between G Road and I70.
- B. **PROJECT SITE DESCRIPTION:** Construct modern style mid-block crossings in three separate locations identified along the Horizon Drive corridor. This is a hazard elimination funded project which includes concrete and asphalt removal, aggregate base course, concrete walk, concrete curb ramps, curb and gutter, concrete median cover material, pedestrian and street lighting, and rectangular rapid flashing beacons.
- C. **ACRES OF DISTURBANCE:**
 - 1. Total area of construction site (LOC): 0.08 acres
 - 2. Total area of disturbance (LDA): 0.08 acres
 - 3. Acreage of seeding: NA acres
- D. **RECEIVING WATER:**
 - 1. Outfall locations: The existing storm pipes adjacent to this project that are underneath and crossing Horizon Drive are owned and maintained by the City of Grand Junction. All storm drain piping adjacent to this project conveys storm water to three separate points that discharge into the Ranchmen's Ditch and then to the Colorado River. This project is located within MS4 boundaries.
 - 2. Names of receiving water(s) on site: Ranchmen's Ditch
 - 3. Ultimate receiving water: Colorado River
 - 4. Horizontal distance nearest water of the state is from project: 3.3 miles
- E. **EXISTING SOIL DATA:** Killpack Silty Clay, 2 to 5 percent slopes. Parent Material: Residuum weathered from clayey shale. Runoff class is: Medium. Depth to water table: More than 80 inches. Hydrologic Soil Group: C.
- F. **EXISTING VEGETATION, INCLUDING PERCENT COVER:** Vegetative transects are *not required*, by permit, on projects with under an acre of disturbance. However, it is advised that transects be completed prior to construction, as a quality control for post construction revegetation assessment. If transects are not completed on a project, at a minimum describe the quality of the existing vegetation.
Existing vegetation consists of maintained landscaping by both the City of Grand Junction and the local businesses adjacent to the project. Existing vegetation consists of sod, trees, shrubs, perennials, and inorganic mulch.

- A. **POTENTIAL POLLUTANT SOURCES**
 - 1. Evaluate, identify and describe all potential sources of pollutants at the site in accordance with subsection 107.25 and place any BMPs/Control Measures required to contain potential pollutants.
- B. **OFFSITE DRAINAGE (RUN ON WATER)**
 - 1. Place BMPs/Control Measures to address run-on water in accordance with subsection 208.03.
- C. **CONSTRUCTION DEWATERING:**
 - 1. Obtain a dewatering permit from CDPHE if conditions of their low risk guidance for Discharges of Uncontaminated Groundwater to Land are not met; see subsection 107.25(b) 8.
- D. **VEHICLE TRACKING PAD**
 - 1. BMPs/Control Measures shall be implemented in accordance with subsection 208.04.
- E. **PERIMETER CONTROL**
 - 1. Perimeter control shall be established as the first item on the SWMP to prevent the potential for pollutants leaving the construction site boundaries, entering the stormwater drainage system, or discharging to state waters.
 - 2. Perimeter control may consist of vegetation buffers, berms, silt fence, erosion logs, existing landforms, or other BMPs/Control Measures as approved.
 - 3. Perimeter control shall be in accordance with subsection 208.04.

3. SWMP ADMINISTRATOR:

A. **SWMP ADMINISTRATOR FOR DESIGN:**

Name/Title	Contact Information
Jerod Timothy/Project Manager	970-244-1565 jerodt@gjcity.org

B. **SWMP ADMINISTRATOR FOR CONSTRUCTION:** (See Subsection 208 Under an Acre Specification) The Contractor shall designate a SWMP Administrator for Construction upon ownership of the SWMP. The SWMP Administrator shall become the owner/operator and assume responsibility for all design changes to the SWMP implementation and maintenance in accordance to 208.03. The SWMP Administrator shall be responsible for implementing, maintaining and revising SWMP, including the title and contact information. The activities and responsibilities of the SWMP administrator shall address all aspects of the projects SWMP. (Update the information below for each new SWMP Administrator) (Copy of TECS Certification must also be included in the SWMP Notebook.) **The SWMP Administration for construction is not a separate pay item but is included in the cost of the work.**

Name/Title	Contact Information	Certification #	Start Date	Engineer Approval

4. DURING CONSTRUCTION

The SWMP should be considered a "living document" that is continuously reviewed and modified. During construction, the following items shall be added, updated, or amended as needed by the Contractor in accordance with Section 208

- A. **MATERIALS HANDLING AND SPILL PREVENTION:** prior to construction commencing the Contractor shall submit a Spill Prevention, Control and Countermeasure Plan, see subsection 208.06. Materials handling shall be in accordance with subsection 208.06.
- B. **STOCKPILE MANAGEMENT:** shall be done in accordance with subsection 107.25 and 208.07

2. STORMWATER MANAGEMENT CONTROLS FIRST CONSTRUCTION ACTIVITIES

Colorado Department of Transportation

606 South 9th Street
Grand Junction, CO, 81501
Phone: 970-683-6351 FAX: 970-683-6369



Region 3

SHY



333 West Ave. Grand Junction, CO, 81501 Phone: 970-244-1554

As Constructed

No Revisions:

Revised:

Void:

STORM WATER MANAGEMENT PLAN

Designer: JCS
Detailer: JCS

Structure Numbers: --
Sheet Subset: General

Project No./Code

SHO M555-033

22497

Sheet Number 37

Sheet Revisions

Date:	Comments	Init.

[APRIL 2016]

PSP Spec.	Pay Item	Description	Pay Unit	Initial Const.	Interim Const.	Permanent Stabilization	*Total Quantity
	208-00106	Sweeping (Sediment Removal)	Hour				
	208-00107	Removal of Trash	Hour				
	208-00300	Temporary Berm	LF				
	208-00301	Temporary Diversion	LF				
	212-00006	Seeding (Native)	Acre				
	212-00009	Seeding (Temporary)	Acre				
	212-00032	Soil Conditioning	Acre				
	213-00002	Mulching (Weed Free Hay)	Acre				
	213-00003	Mulching (Weed Free)	Acre				
	213-00004	Mulching (Weed Free Straw)	Acre				
	213-00012	Spray-on Mulch Blanket	Acre				
	213-00013	Spray-on Mulch Blanket	LB				
	213-00061	Mulch Tackifier	LB				
	213-00150	Bonded Fiber Matrix	Acre				
	213-00151	Bonded Fiber Matrix	LB				
	214-00000	Landscape Maintenance	LS				
	214-00005	Landscape Maintenance (24 Month)	LS				
	216-00101	Soil Retention Blanket (Straw/Coconut) (Photodegradable Class 1)	SY				
	216-00111	Soil Retention Blanket (Excelsior) (Photodegradable Class 1)	SY				

PSP Spec.	Pay Item	Description	Pay Unit	Initial Const.	Interim Const.	Permanent Stabilization	*Total Quantity
	216-00122	Soil Retention Blanket (Coconut) (Photodegradable Class 2)	SY				
	216-00201	Soil Retention Blanket (Straw/Coconut) (Biodegradable Class 1)	SY				
	216-00211	Soil Retention Blanket (Excelsior) (Biodegradable Class 1)	SY				
	216-00222	Soil Retention Blanket (Coconut) (Biodegradable Class 2)	SY				
	216-00301	Turf Reinforcement Mat (Class 1)	SY				
	216-00302	Turf Reinforcement Mat (Class 2)	SY				
	216-00303	Turf Reinforcement Mat (Class 3)	SY				
	217-00000	Herbicide Treatment	SY				
	217-00020	Herbicide Treatment	Hour				
	607-11525	Fence (Plastic)	LF				
	615-00152	Erosion Protector (Special)	LF				
	700-70380	Erosion Control	FA				

*It is anticipated that additional BMPs/Control Measures and BMP/Control Measure quantities not shown on the SWMP Site Maps shall be required on the project for unforeseen conditions and replacement of items that are beyond their useful service life, see subsection 208.03 and 208.04. **Quantities for all BMPs/Control Measures shown above are estimated, and have been increased for unforeseen conditions and normal BMP/Control Measure life expectancy.** Quantities shall be adjusted according to the conditions encountered in the field as directed and approved by the Engineer. Payment shall be for the actual work completed and material used.

10. BIOLOGIC IMPACTS

A. ENVIRONMENTAL IMPACTS:

1. Wetland Impacts: NO
2. Stream Impacts: NO
3. Threatened and Endangered Species: No species are anticipated to be impacted by the project.

11. Notes

- A. ECM (or SWMP Administrator For Construction or Erosion Control Inspector) is included in the cost of the work.

Colorado Department of Transportation

606 South 9th Street
Grand Junction, CO, 81501
Phone: 970-683-6351 FAX: 970-683-6369



Region 3

SHY

Sheet Revisions

Date:	Comments	Init.



333 West Ave. Grand Junction, CO, 81501 Phone: 970-244-1554

As Constructed

No Revisions:

Revised:

Void:

STORM WATER MANAGEMENT PLAN

Designer:	JCS	Structure Numbers	-
Detailer:	JCS	Structure Numbers	-
Sheet Subset:	General	Subset Sheets:	1 of 1

Project No./Code

SHO M555-033

22497

Sheet Number 42

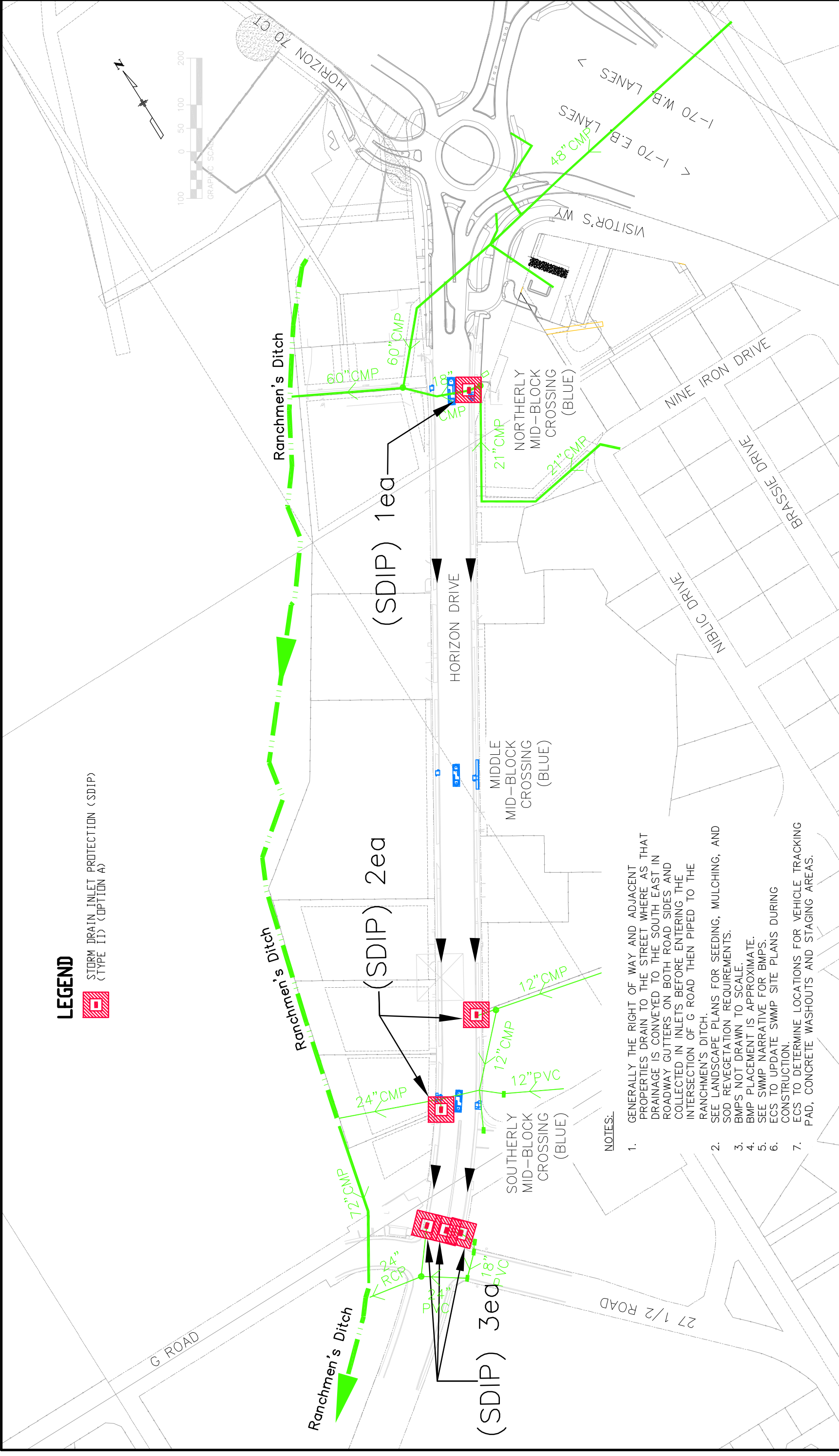

LEGEND

STORM DRAIN INLET PROTECTION (SDIP)
(TYPE II) (OPTION A)



NOTES:

1. GENERALLY THE RIGHT OF WAY AND ADJACENT PROPERTIES DRAIN TO THE STREET WHERE AS THAT DRAINAGE IS CONVEYED TO THE SOUTH EAST IN ROADWAY GUTTERS ON BOTH ROAD SIDES AND COLLECTED IN INLETS BEFORE ENTERING THE INTERSECTION OF G ROAD THEN PIPED TO THE RANCHMEN'S DITCH.
2. SEE LANDSCAPE PLANS FOR SEEDING, MULCHING, AND SOD REVEGETATION REQUIREMENTS.
3. BMPs NOT DRAWN TO SCALE.
4. BMP PLACEMENT IS APPROXIMATE.
5. SEE SWMP NARRATIVE FOR BMPs.
6. ECS TO UPDATE SWMP SITE PLANS DURING CONSTRUCTION.
7. ECS TO DETERMINE LOCATIONS FOR VEHICLE TRACKING PAD, CONCRETE WASHOUTS AND STAGING AREAS.

Colorado Department of Transportation 606 South 9th Street Grand Junction, CO, 81501 Phone: 970-683-6351 FAX: 970-683-6369 SHY	Sheet Revisions <table border="1"> <thead> <tr> <th>Date:</th> <th>Comments</th> <th>Init.</th> </tr> </thead> <tbody> <tr> <td> </td> <td> </td> <td> </td> </tr> <tr> <td> </td> <td> </td> <td> </td> </tr> <tr> <td> </td> <td> </td> <td> </td> </tr> </tbody> </table>		Date:	Comments	Init.										CITY OF Grand Junction C O L O R A D O 333 West Ave. Grand Junction, CO, 81501 Phone: 970-244-1554		As Constructed No Revisions: Revised: Void:		STORM WATER MANAGEMENT SITE PLAN Designer: JCS Detailer: JCS Sheet Subset: General		Project No./Code SHO M555-033 22497		Sheet No./Code 43 1 of 1	
	Date:	Comments	Init.																					

SIGN CODE	SIGN PANEL SIZE		LEGEND	(630-80341) CONSTRUCTION TRAFFIC SIGN (PANEL SIZE A)		(630-80342) CONSTRUCTION TRAFFIC SIGN (PANEL SIZE B)	
	W"	H"		Plan	As Const	Plan	As Const
G20-1	48	X 24	ROAD / WORK / NEXT XX MILES				
W20-1	48	X 48	ROAD / WORK / AHEAD			2	
W20-5 (R)	48	X 48	RIGHT LANE / CLOSED / 1/2 MILE				
W20-7a	48	X 48	FLAGGER AHEAD (SYMBOL)			2	
R2-1 (60)	48	X 60	SPEED / LIMIT / 60				
R2-1 (45)	48	X 60	SPEED / LIMIT / 30				
R2-1 (15)	36	X 48	SPEED / LIMIT / 15			2	
R3-7 (L)	30	X 30	LEFT LANE / MUST TURN / LEFT				
R3-7 (R)	30	X 30	RIGHT LANE / MUST TURN / RIGHT				
W8-3	48	X 48	PAVEMENT / ENDS				
W8-1	48	X 48	BUMP				
W21-5	48	X 48	SHOULDER / WORK			2	
W8-9a	48	X 48	SHOULDER / DROP OFF				
W8-11	48	X 48	UNEVEN LANES			2	
W20-4	48	X 48	ONE LANE / ROAD / AHEAD				
W4-1 (R)	36	X 36	MERGE SYMBOL	2			
W1-4 (L)	36	X 36	TRAFFIC SHIFT SYMBOL (TO LEFT)	2			
W1-4 (R)	36	X 36	TRAFFIC SHIFT SYMBOL (TO RIGHT)	2			
R4-1	36	X 48	DO / NOT / PASS			2	
R4-2	36	X 48	PASS / WITH / CARE				
W5-1	36	X 36	ROAD / NARROWS	2			
W5-4	48	X 48	RAMP / NARROWS				
W20-63	48	X 48	RAMP / WORK / AHEAD				
R11-2	48	X 48	ROAD / CLOSED				
R11-3a	60	X 30	ROAD CLOSED / LOCAL TRAFFIC ONLY				
G20-2	48	X 48	END / ROAD / WORK			2	
G20-10	48	X 48	XYZ / CONSTRUCTION / THANKS / 555-555-5555			2	
R6-1	36	X 12	ONE WAY (INSIDE ARROW)				
R52-6a	48	X 60	BEGIN / FINES / DOUBLE / IN WORK / ZONE				
R52-6a	36	X 48	BEGIN / FINES / DOUBLE / IN WORK / ZONE			2	
G20-5	36	X 12	WORK ZONE				
G20-5	48	X 12	WORK ZONE	2			
G20-11 *	48	X 48	CONSTRUCTION INFORMATION *				
R2-6	36	X 18	FINES / DOUBLE	2			
R52-6b	48	X 60	END / FINES / DOUBLE / IN WORK / ZONE				
R52-6b	36	X 48	END / FINES / DOUBLE / IN WORK / ZONE			2	
R9-9	36	X 18	SIDEWALK / CLOSED	4			
R9-11 (R)	36	X 18	SIDEWALK / CLOSED / CROSS HERE (RIGHT)				
R9-11 (L)	36	X 18	SIDEWALK / CLOSED / CROSS HERE (LEFT)				
W3-5a	48	X 48	15 MPH / SPEED ZONE / AHEAD			2	
W4-2	48	X 48	LANE ENDS (SYMBOL)			2	
W3-4	48	X 48	BE / PREPARED / TO STOP			2	
				PROJECT TOTALS =		16	26

* SEE PROJECT SPECIAL PROVISIONS - PUBLIC INFORMATION SPECIFICATION

ITEM NUMBER	ITEM DESCRIPTION	UNIT	PLAN QUANTITY	AS CONST.
630-00000	FLAGGING	HOUR	100	
630-00007	TRAFFIC CONTROL INSPECTION	DAY	20	
630-00012	TRAFFIC CONTROL MANAGEMENT	DAY	20	
630-80336	BARRICADE (TYPE 3 M-B)(TEMPORARY)	EACH	2	
630-80358	ADVANCE WARNING FLASHING OR SEQUENCING ARROW PANEL (C TYPE)	EACH	2	
630-80359	PORTABLE MESSAGE SIGN PANEL	DAY	20	
630-80360	DRUM CHANNELIZING DEVICE	EACH	40	
630-80363	DRUM CHANNELIZING DEVICE (WITH LIGHT)(FLASHING)	EACH	60	
630-80364	DRUM CHANNELIZING DEVICE (WITH LIGHT)(STEADY BURR)	EACH		
630-80377	PORTABLE WATER FILLED BARRIER (TEMPORARY)	LF		
630-80390	CHANNELIZING DEVICE (SPECIAL)	EACH		
630-86800	TRAFFIC SIGNAL (TEMPORARY)	LS		

SCHEDULE OF CONSTRUCTION SIGN PANEL (SPECIAL) 630-80344

ITEM	DIMENSION	EACH	SQ. FT.	QUANTITY EACH	TOTAL SQ. FT.	AS CONST.
GRAND JUNCTION / ALL BUSINESS / ACCESS OPEN	48" x 30"		10	2	20	
TOTAL						

Colorado Department of Transportation
 606 South 9th Street
 Grand Junction, CO, 81501
 Phone: 970-683-6351 FAX: 970-683-6369
 SHY

CITY OF

 333 West Ave. Grand Junction, CO, 81501 Phone: 970-244-1554

As Constructed
 No Revisions:
 Revised:
 Void:

Designers: JCS
Detailers: JCS
 Sheet Subset: TAB









Project No./Code
 SHO M555-033
 22497

TABULATION OF TRAFFIC CONTROL DEVICES
 Structure Numbers: -
 Subst Sheets: 1 of 1
 Sheet Number: 44

STREET LIGHTING GENERAL NOTES:

- THIS PROJECT CONSISTS OF WORK TO INSTALL ALL WIRING, CONDUIT, PULL BOXES, POWER PANEL AND CONTROLLER, ADDITIONAL PEDESTRIAN LIGHTING, FOUNDATIONS, CONDUIT AND WIRING WILL BE INSTALLED AT A LATER DATE AS DETERMINED BY THE CITY OF GRAND JUNCTION. REFERENCE SCHEDULE OF LIGHTING DEVICES AND SUMMARY OF QUANTITIES DRAWING LE2.
- THE CONTRACTOR SHALL FURNISH AND INSTALL 30" LIGHT STANDARDS WITH DOUBLE 10' ARMS, TYPICAL BREAK AWAY TYPE TRANSFORMER BASE. AS SPECIFIED ON THE PLANS. THE ITEMS NUMBERS ARE AS FOLLOWS. FROM M & H LIGHTING LOCATED AT 1044 SPEER BOULEVARD, DENVER, CO 80204-0222, 303.573.0222. THE ITEMS NUMBERS ARE AS FOLLOWS.
 - 30" BLACK POLE: EXCEL ID # 213432, VALMONT PART #213432, PART#DB00880-800A30-9017/BK
 - 10' ARMS (DOUBLE): EXCEL ID#213412, VALMONT PART #B00880-MD-10-9017/BK
- THE CONTRACTOR SHALL FURNISH AND INSTALL THE FOLLOWING ITEMS FROM MOUNTAIN STATES LIGHTING, P.O. BOX 449, CONIFER, CO, 303.838.4430, LUMINAIRE:
 - TYPE 5LD GE LIGHTING - CATALOG NO. ERLH-O-15-E140-D-GRAY035
- LIGHT STANDARD & LUMINAIRE (PEDESTRIAN), SHALL INCLUDE THE FOLLOWING ITEMS FROM M & H LIGHTING LOCATED AT 1044 SPEER BOULEVARD, DENVER, CO 80204-0222, 303.573.0222. THE ITEMS NUMBERS ARE AS FOLLOWS.
 - TYPE 5A STERNBERG LIGHTING- CATALOG NO. 1220LEDPT54 PT/55Q14/4A1R35T3/MLW/BKT
- TYPE "5LD" STANDARD AND THE "5A" STANDARD WILL NOT BE ORDERED WITH A PHOTO CELL.
- ALL LIGHTING TYPE "5A" AND TYPE "5LD" LUMINAIRE INSTALLED ON THE PROJECT WILL BE CONTROLLED WITH A CENTRALIZED PHOTO CELL LOCATED AT THE POWER PANEL.
- THE CONTRACTOR SHALL FURNISH AND INSTALL RECTANGULAR RAPID FLASHING BEACON SYSTEM TO BE ORDERED FROM CARMANAH TECHNOLOGIES CORPORATION 877.722.8877. RECTANGULAR RAPID FLASHING BEACON SYSTEM "FB-3", "FB-7" AND "FB-10" WILL BE ORDERED WITH HARDWARE TO MOUNT TO LIGHT POLE.
 - CARMANAH - CATALOG NO. SC-315
- THE CONTRACTOR SHALL FURNISH AND INSTALL THE POWER PEDESTAL "PP2" FROM MILBANK MANUFACTURING:
 - MILBANK - CATALOG NO. CP3B511HA22C55L1
- ELEVATIONS SHOWN IN THE SCHEDULE OF LIGHTING DEVICES ON THE PLANS SHEETS REPRESENT THE DESIGN FINISHED GRADE OR THE EXISTING GROUND FINISHED GRADE. THESE ELEVATIONS DO NOT INDICATE THE TOP ELEVATION OF THE LIGHT STANDARD FOUNDATION. LIGHT STANDARD FOUNDATIONS FOR THE 30" POLES SHALL BE CONSTRUCTED AS INDICATED IN DRAWINGS. PEDESTRIAN LIGHTING FOUNDATIONS SHALL BE CONSTRUCTED PER THE MANUFACTURERS RECOMMENDATIONS.
- PULL BOXES FOR LIGHT STANDARD (PEDESTRIAN) WILL BE TYPE 1 CDOT PULL BOXES 11'X18'X12". PULL BOXES FOR FUTURE LIGHTING WILL HAVE 10' OF WIRING COILED IN PULL BOX FOR CONNECTION TO FUTURE LIGHTING.
- PULL BOXES FOR LIGHT STANDARD WILL BE CDOT TYPE 1, 11'X18'X12". EACH STANDARD LIGHT WILL HAVE A PULL BOX INSTALLED NEAR THE LIGHT. PULL BOXES WILL BE INSTALLED IN GRADES WITHOUT CONCRETE WHERE POSSIBLE.
- ALL NEW ELECTRICAL CONDUIT SHALL BE SCHEDULE 80 PVC UNLESS NOTED OTHERWISE, TYPICAL. EACH WILL HAVE PULL STRING AND TRACE WIRE INSTALLED. ALL LOADS TO BE WIRED IN PARALLEL TO AVOID EXCESSIVE VOLTAGE DROP.
- UNLESS OTHERWISE NOTED, THE WORK DESCRIBED ON THE PLANS SHALL INCLUDE PROVIDING ALL LABOR AND MATERIALS NECESSARY FOR A COMPLETE AND OPERATIONAL ELECTRICAL SYSTEM. FURNISH ALL REQUIRED ITEMS WHETHER SUCH ARE SPECIFICALLY SHOWN OR NOT.
- INFORMATION SHOWN ON DRAWINGS IS DIAGRAMMATIC ONLY AND SHALL NOT BE SCALED. OBTAIN VERIFY EXACT LOCATIONS, MEASUREMENTS, LEVELS, SPACE REQUIREMENTS, POTENTIAL CONFLICTS AMONG TRADES AND FOR ADJUSTING THE WORK REQUIRED BY THE ACTUAL CONDITIONS OF THE PROJECT. CONTRACTOR IS RESPONSIBLE FOR LOCATING ALL UNDER GROUND OBSTRUCTIONS AND MAKING ALLOWANCES FOR FIELD ADJUSTMENT OF LOCATION OF LUMINARIES TO AVOID SHUT DOWN OF ANY SERVICES OR SYSTEMS THAT ARE TO REMAIN.
- DEMOLITION AND REMOVAL OF EXISTING LUMINARIES, FOUNDATIONS, WIRING AND CONDUIT TO BE COMPLETED BY CONTRACTOR AS PART OF THIS CONTRACT.
- BEFORE SUBMITTING THE BID ELECTRICAL CONTRACTOR SHALL VISIT AND EXAMINE THE PREMISES AND/OR JOB SITE SO AS TO ASCERTAIN THE EXISTING CONDITIONS IN WHICH HE WILL BE OBLIGED TO OPERATE IN PERFORMING HIS PART OF THE CONTRACT TO ANTICIPATE ANY POSSIBLE SPACE RESTRICTIONS OR CONSTRAINTS THAT COULD AFFECT THE TIMELY COMPLETION OF THE ELECTRICAL WORK IN ACCORDANCE WITH THE INTENT OF THE SPECIFICATIONS AND DRAWINGS. THE ELECTRICAL CONTRACTOR SHALL REPORT TO THE PROJECT ENGINEER OR GENERAL CONTRACTOR ANY CONDITIONS THAT MIGHT PREVENT THE SPECIFIED ELECTRICAL WORK FROM BEING PERFORMED IN THE MANNER INTENDED. NO CONSIDERATION OR ALLOWANCE WILL BE GRANTED TO THE ELECTRICAL CONTRACTOR FOR FAILURE TO VISIT THE PROJECT SITE, OR FOR ANY ALLEGED MISUNDERSTANDING OF THE MATERIALS TO BE FURNISHED OR WORK TO BE DONE.
- THE ELECTRICAL CONTRACTOR SHALL EXAMINE THE DRAWINGS OF ALL TRADES WHOSE WORK RELATES TO OR IS DEPENDENT ON ELECTRICAL WORK TO BECOME FULLY INFORMED OF THE EXTENT AND CHARACTER OF THEIR SPECIFIED WORK AND BE ABLE TO COORDINATE WITH OTHER TRADES WHILE AVOIDING POSSIBLE INTERFERENCE WITH THE ELECTRICAL WORK.

LIGHTING LEGEND

-  NEW ROADWAY LIGHT STANDARD, 161W LED TYPE E1 LUMINAIRE, 30' POLE AND NEW CONCRETE FOUNDATION.
-  SLD-1 LIGHT STANDARD IDENTIFICATION NUMBER, 30' TWO ARM
-  PP1-X ELECTRICAL CIRCUIT NUMBER (REFER TO PANEL SCHEDULES)
-  UB  HEAVY DUTY, TRAFFIC RATED, FLUSH-TO-GRADE POLYMER CONCRETE SPLICE BOX WITH HEAVY DUTY, TRAFFIC RATED, BOLTED COVER. 11'X18'X12" TYPE 1.
-  UNDER GROUND BURIED RACEWAY (2#2 THWN CU AND 1#2 GND) N 2" PVC CONDUIT (UNLESS NOTED OTHERWISE ON PLANS) IN 24" DEEP TRENCH, BURY AND COMPACTED BACKFILL TO PRE CONSTRUCTION CONDITION.
-  POST TOP PEDESTRIAN STANDARD.
-  RECTANGULAR RAPID FLASHING BEACON SYSTEM STANDARD.

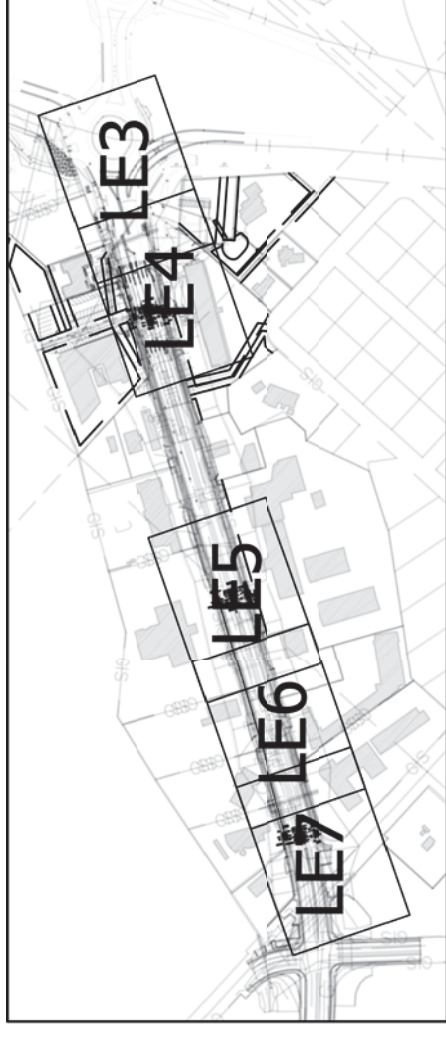
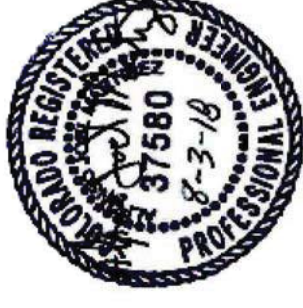

LIGHTING PLAN KEY MAP

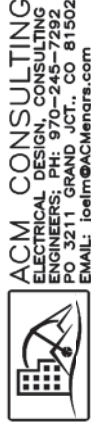

Colorado Department of Transportation  606 South 9th Street Grand Junction, CO, 81501 Phone: 970-683-6351 FAX: 970-683-6369 Region 3	Sheet Revisions		As Constructed		HORIZON DRIVE CROSSWALKS LIGHTING GENERAL NOTES Designer: JCS Structure Numbers Detailer: JCS Sheet Subset: General	Project No./Code SHO M555-033 22497
	Date:	Comments	No Revisions:	Void:		
CITY OF Grand Junction C O L O R A D O  333 West Ave. Grand Junction, CO, 81501 Phone: 970-244-1554		No Revisions: Revised: Void:		SHEET NO. 1 of 11 SUBSET SHEETS: 1 of 11		Project No./Code SHO M555-033 22497

Schedule of Lighting Devices

LONG DESCRIPTION UNITS	LIGHT STANDARD METAL (30 FOOT) (2 ARM) EACH		LIGHT STANDARD FOUNDATION EACH		LIGHT STANDARD AND LUMINAIRE (PEDESTRIAN 95 WATT) EACH		NOTES
	PLAN	AS CONST	PLAN	EACH	PLAN	AS CONST	
SHEET NO. I.D. NO.	E	N					
LE-4 FB-1	97755.29	51473.04					
LE-4 FB-2	97794.42	51458.99					
LE-4 FB-3	97772.92	51422.29					
LE-4 FB-4	97808.87	51405.52					
LE-4 SA-1	97746.26	51464.49	1		1		1,2
LE-4 SA-2	97815.38	51415.42	1		1		1,2
LE-4 SLD-1	97772.92	51422.29	1				3
LE-5 FB-5	97329.94	50769.08					
LE-5 FB-6	97365.72	50753.55					
LE-5 FB-7	97348.69	50725.50					
LE-5 FB-8	97384.28	50709.34					
LE-5 SA-3	97320.71	50760.76	1		1		1,2
LE-5 SA-4	97392.26	50718.23	1		1		1,2
LE-5 SLD-2	97348.69	50725.50	1				3
LE-7 FB-10	96983.28	50132.58					
LE-7 FB-11	97001.99	50159.53					
LE-7 FB-12	97022.5738	50111.7818					
LE-7 FB-9	96966.83	50177.58					
LE-7 SA-5	96959.16	50168.56	1		1		1,2
LE-7 SA-6	97025.99	50123.18	1		1		1,2
LE-7 SLD-3	96983.28	50132.58	1				3
PROJECT TOTALS				9		6	

SCHEDULE OF LIGHTING DEVICES NOTES:

- FOUNDATION TOP HEIGHT EQUAL TO ADJACENT SIDEWALK
- LUMINAIRE LED (95 WATT) IS TO BE INCLUDED IN THE COST OF PAY ITEM LIGHT STANDARD AND LUMINAIRE (PEDESTRIAN)
- FOUNDATION PER CDOT STANDARD M-613-1

Tabulation of Lighting/Electrical Quantities

Item No.	Construction Note Description	Quantity	Unit	NOTES
	Lighting Control Center (Special)	1	EA	
	Light Standard and Luminaire (Pedestrian)	6	EA	
	Luminaire LED Street 2-Head (365 watt)	3	EA	
	wiring	1	LS	

SUMMARY NOTES:

Colorado Department of Transportation

 606 South 9th Street
 Grand Junction, CO, 81501
 Phone: 970-683-6351 FAX: 970-683-6369
Region 3
 SHY

Sheet Revisions

Date:	Comments	Init.

CITY OF Grand Junction
COLORADO
 333 West Ave. Grand Junction, CO, 81501 Phone: 970-244-1554

As Constructed

No Revisions:	
Revised:	
Void:	

HORIZON DRIVE CROSSWALKS LIGHTING SCHEDULES
 Designer: JCS Structure Numbers
 Detailer: JCS
 Sheet Subset: General Subst Sheets: 2 of 11

Project No./Code
 SHO M555-033
 22497
 LE2 46



ACM CONSULTING
 ELECTRICAL DESIGN CONSULTING ENGINEERS, P.L.L.C.
 P.O. 3211 GRAND JCT, CO 81502
 EMAIL: joalm@acmengr.com



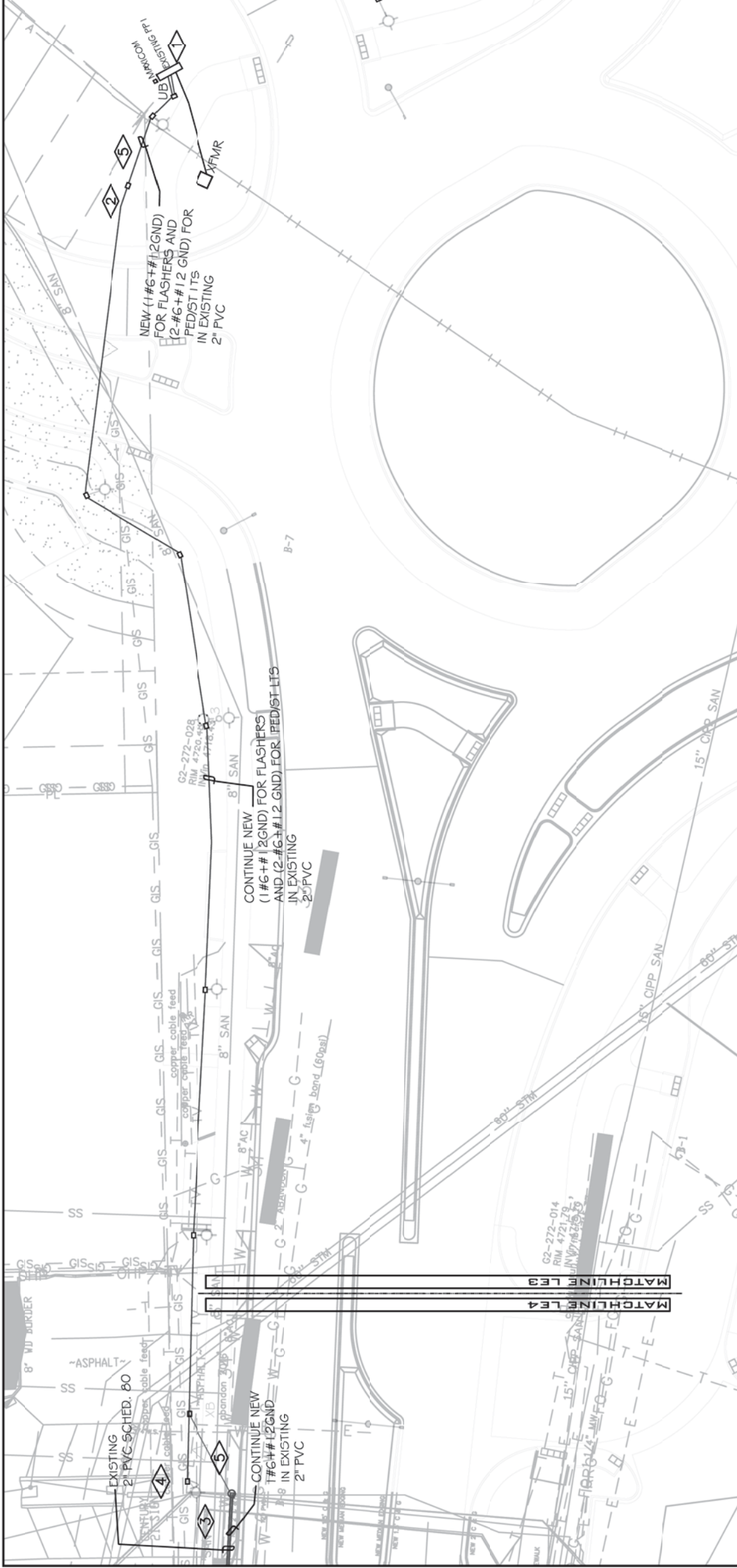

LIGHTING/ELECTRICAL PLAN

SCALE: 1"=40'

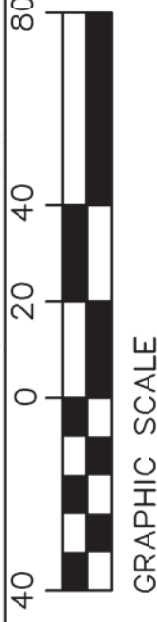

FLAG NOTES:

- 1 PROVIDE NEW 1 POLE 120 VOLT CIRCUIT BREAKER IN PANEL PP1 TO POWER FLASHERS. WIRE WITH (#6 THWN CU + #12 GND)
- 2 CONNECT NEW (#6 THWN CU + #12 GND) FROM EXISTING SPARE 20 AMP 2 POLE BREAKER. RUN WIRE IN EXISTING 2" CONDUIT FROM PP1 TO NEW CROSSWALK STREET AND PEDESTRIAN LIGHTS. POWER FROM BREAKER TO BE ROUTED VIA EXISTING CONTACTOR, NEXT TO PANEL PPI, FOR AUTOMATIC ON OFF FUNCTIONS. UPDATE PANEL SCHEDULE AND LABEL WIRING, TYPICAL.
- 3 PROVIDE EMPTY 2" SCHEDULE 80 CONDUIT TO NEW JBOX FOR FUTURE, REFERENCE DWG LE4. PROVIDE PULL STRING AND TRACE WIRE FOR CONDUIT.
- 4 PULL BOXES AND CONDUIT ARE EXISTING BACK TO PANEL 'PP1'.
- 5 RUN NEW WIRE TO CROSSWALK IN NEXT AVAILABLE CONDUIT WITH ADEQUATE SPACE. FIELD VERIFY CONDUITS HAVE REQUIRED SPACE PER NEC PRIOR TO INSTALLATION OF NEW WIRE, TYPICAL.



Know what's below.
Call before you dig.

ACM CONSULTING
ELECTRICAL DESIGN CONSULTING
PROJECT: GRAND JCT. CO. 81502
EMAIL: joelm@ACMengr.com

<p>Colorado Department of Transportation</p> <p>606 South 9th Street Grand Junction, CO, 81501 Phone: 970-683-6351 FAX: 970-683-6369</p> <p style="text-align: right;">Region 3</p>	<p>CITY OF Grand Junction C O L O R A D O</p> <p style="text-align: right; font-size: small;">333 West Ave. Grand Junction, CO, 81501 Phone: 970-244-1554</p>	<p>As Constructed</p> <p>No Revisions: _____</p> <p>Revised: _____</p> <p>Void: _____</p>	<p>HORIZON DRIVE NORTH CROSSWALK LIGHTING PLAN</p> <p>Designer: JCS</p> <p>Detailer: JCS</p> <p>Sheet Subset: General</p>	<p>Project No./Code</p> <p>SHO M555-033</p> <p>22497</p> <p>LE3</p>														
	<table border="1" style="width: 100%; border-collapse: collapse;"> <thead> <tr> <th colspan="2">Sheet Revisions</th> </tr> <tr> <th style="width: 50%;">Date:</th> <th style="width: 50%;">Comments</th> </tr> </thead> <tbody> <tr> <td> </td> <td>Init.</td> </tr> <tr> <td> </td> <td> </td> </tr> <tr> <td> </td> <td> </td> </tr> <tr> <td> </td> <td> </td> </tr> </tbody> </table>	Sheet Revisions		Date:	Comments		Init.							<table border="1" style="width: 100%; border-collapse: collapse;"> <tr> <td style="width: 50%;">Structure Numbers</td> <td style="width: 50%;"> </td> </tr> <tr> <td>Sheet Subsets: General</td> <td>3 of 11</td> </tr> </table>	Structure Numbers		Sheet Subsets: General	3 of 11
Sheet Revisions																		
Date:	Comments																	
	Init.																	
Structure Numbers																		
Sheet Subsets: General	3 of 11																	

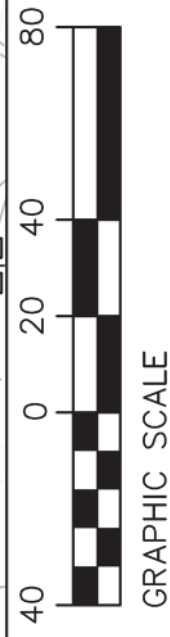
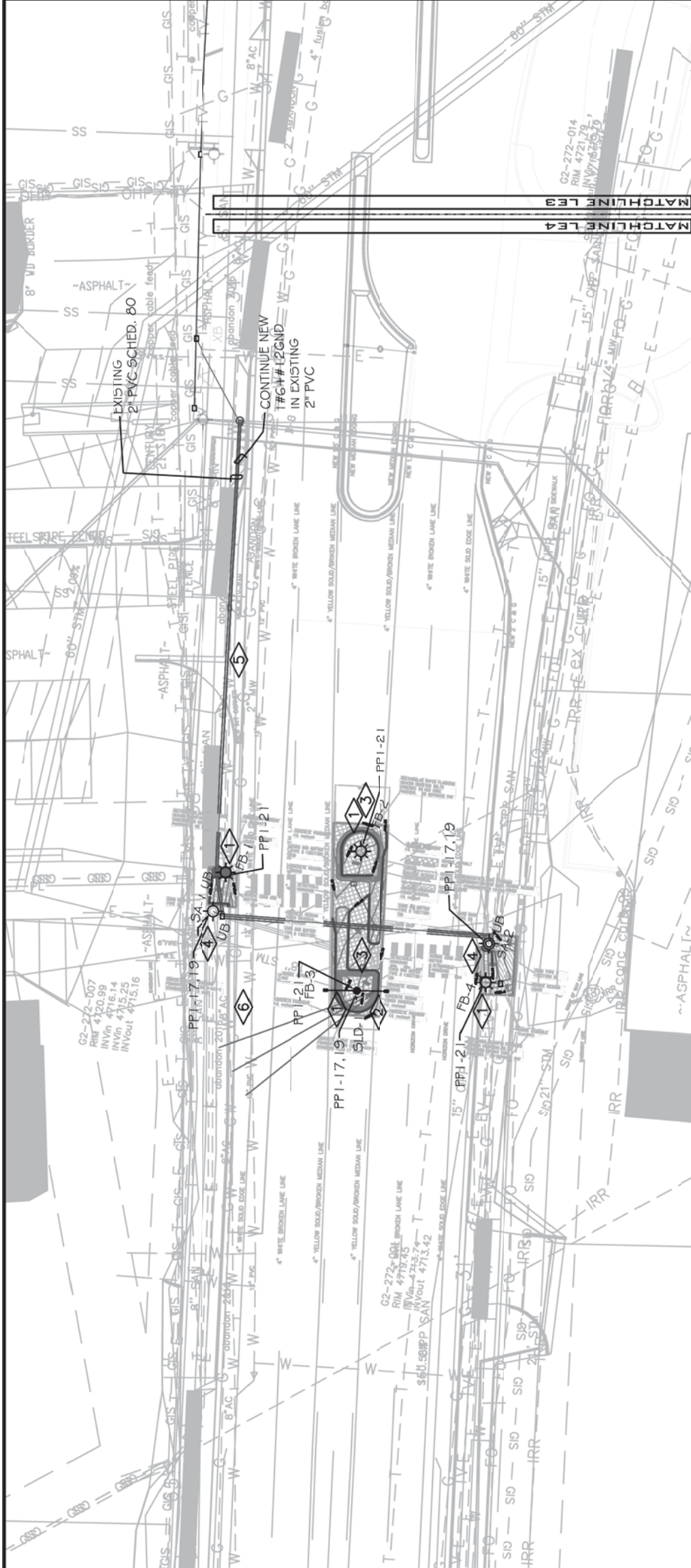

LIGHTING/ELECTRICAL PLAN

SCALE: 1"=40'

FLAG NOTES:

- 1 WIRE NEW RECTANGULAR RAPID FLASHING BEACON SYSTEM TO NEW 120 VOLT 20 AMP CIRCUIT FROM PANEL PPI. FIELD VERIFY EXACT LOCATION WITH OWNER AND COORDINATE INSTALLATION WITH PROVIDER PRIOR ROUGH-IN.
- 2 WIRE NEW DOUBLE ARM 30' LIGHT POLE TYPE SLD TO NEW 240 VOLT 20 AMP 2-POLE CIRCUIT. CIRCUIT TO BE CONTROLLED VIA CONTACTOR LOCATED NEXT TO PANEL PP-1
- 3 NEW RECTANGULAR RAPID FLASHING BEACON SYSTEM 'FB-3' TO BE MOUNTED TO LIGHT POLE. COORDINATE INSTALLATION WITH PROVIDER PRIOR TO ROUGH-IN.
- 4 WIRE NEW PEDESTRIAN LIGHT TO NEW 20 AMP 208 VOLT 2-POLE CIRCUIT. CIRCUIT TO BE CONTROLLED VIA CONTACTOR LOCATED NEXT TO PANEL PP-1
- 5 WIRING TO BE (#6 THWN CU + #12 GND) UNLESS OTHERWISE NOTED.
- 6 EACH TYPE 'SA' AND 'SLD' TYPE FIXTURES TO HAVE TYPE 1 PULL BOX, TYPICAL.



ACM CONSULTING
ELECTRICAL DESIGN, CONSULTING
ENGINEERS; PH: 970-245-7292
PO. 3211 GRAND, JCT., CO. 81502
EMAIL: joel@ACMengrs.com

Colorado Department of Transportation 606 South 9th Street Grand Junction, CO, 81501 Phone: 970-683-6351 FAX: 970-683-6369 Region 3	Sheet Revisions		CITY OF Grand Junction COLORADO 333 West Ave. Grand Junction, CO, 81501 Phone: 970-244-1554	As Constructed No Revisions: Revised: Void:	HORIZON DRIVE NORTH CROSSWALK LIGHTING PLAN Designer: JCS Detailer: JCS Sheet Subset: General	Project No./Code SHO M555-033 22497
	Date:	Comments				
					LE4	
					48	

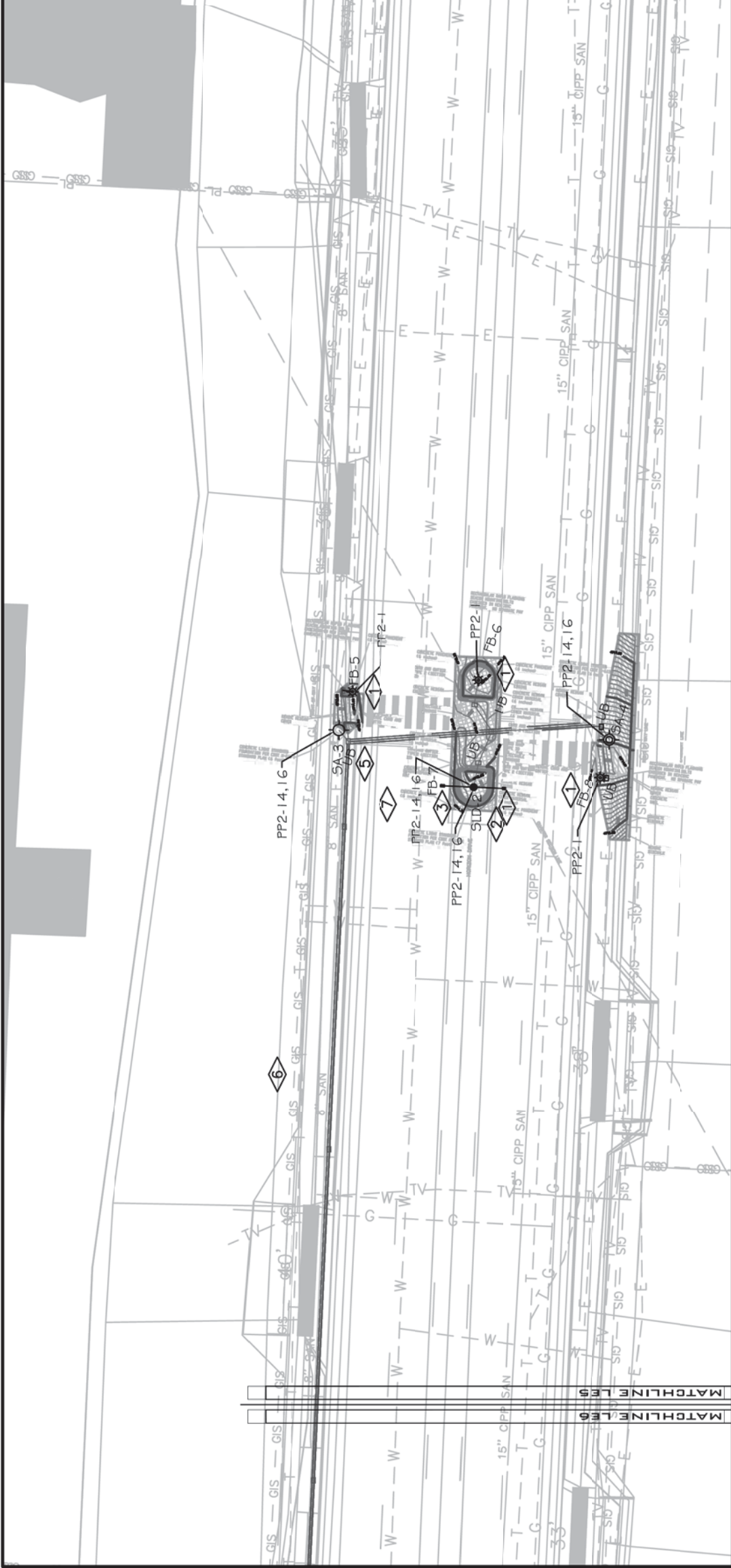

LIGHTING/ELECTRICAL PLAN

SCALE: 1"=40'



GRAPHIC SCALE

FLAG NOTES:

- 1 WIRE NEW RECTANGULAR RAPID FLASHING BEACON SYSTEM TO NEW 120 VOLT 20 AMP CIRCUIT IN NEW PANEL PP2. FIELD VERIFY EXACT LOCATION WITH OWNER AND COORDINATE INSTALLATION WITH PROVIDER PRIOR ROUGH-IN.
- 2 WIRE NEW DOUBLE ARM 30' LIGHT POLE TYPE SLD TO NEW 240 VOLT 20 AMP 2-POLE CIRCUIT. CIRCUIT TO BE SWITCHED ON AND OFF AT CABINET.
- 3 NEW RECTANGULAR RAPID FLASHING BEACON SYSTEM 'FB-7' TO BE MOUNTED TO LIGHT POLE. COORDINATE INSTALLATION WITH PROVIDER PRIOR TO ROUGH-IN.
- 4 WIRE NEW PEDESTRIAN LIGHT TO NEW 20 AMP 208 VOLT 2-POLE CIRCUIT IN PANEL PP2.
- 5 STUB UP EMPTY 2" CONDUIT IN JBOX, PROVIDE PULL STRING, PLUGS AND TRACE WIRE.
- 6 WIRING TO BE <#6 THWN CU + #12 GND> UNLESS OTHERWISE NOTED.
- 7 EACH TYPE 'SA' AND 'SLD' TYPE FIXTURES TO HAVE TYPE 1 PULL BOX, TYPICAL.



Know what's below.
Call before you dig.

ACM CONSULTING
ELECTRICAL DESIGN CONSULTING
ENGINEERS: PH: 970-245-7292
PO. 3211 GRAND JCT. CO. 81502
EMAIL: joalm@ACMengr.com

Colorado Department of Transportation



606 South 9th Street
Grand Junction, CO, 81501
Phone: 970-683-6351 FAX: 970-683-6369

Region 3

SHY

CITY OF
Grand Junction
C O L O R A D O

333 West Ave. Grand Junction, CO, 81501 Phone: 970-244-1554

As Constructed

No Revisions:

Revised:

Void:

HORIZON DRIVE CENTER CROSSWALK
LIGHTING PLAN

Designer: JCS

Detailer: JCS

Sheet Subset: General

Project No./Code

SHO M555-033

22497

LE5

5 of 11

49

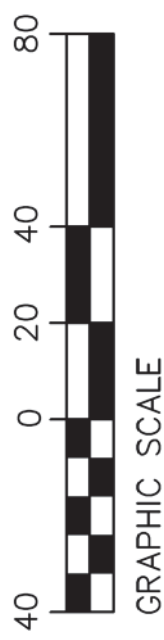
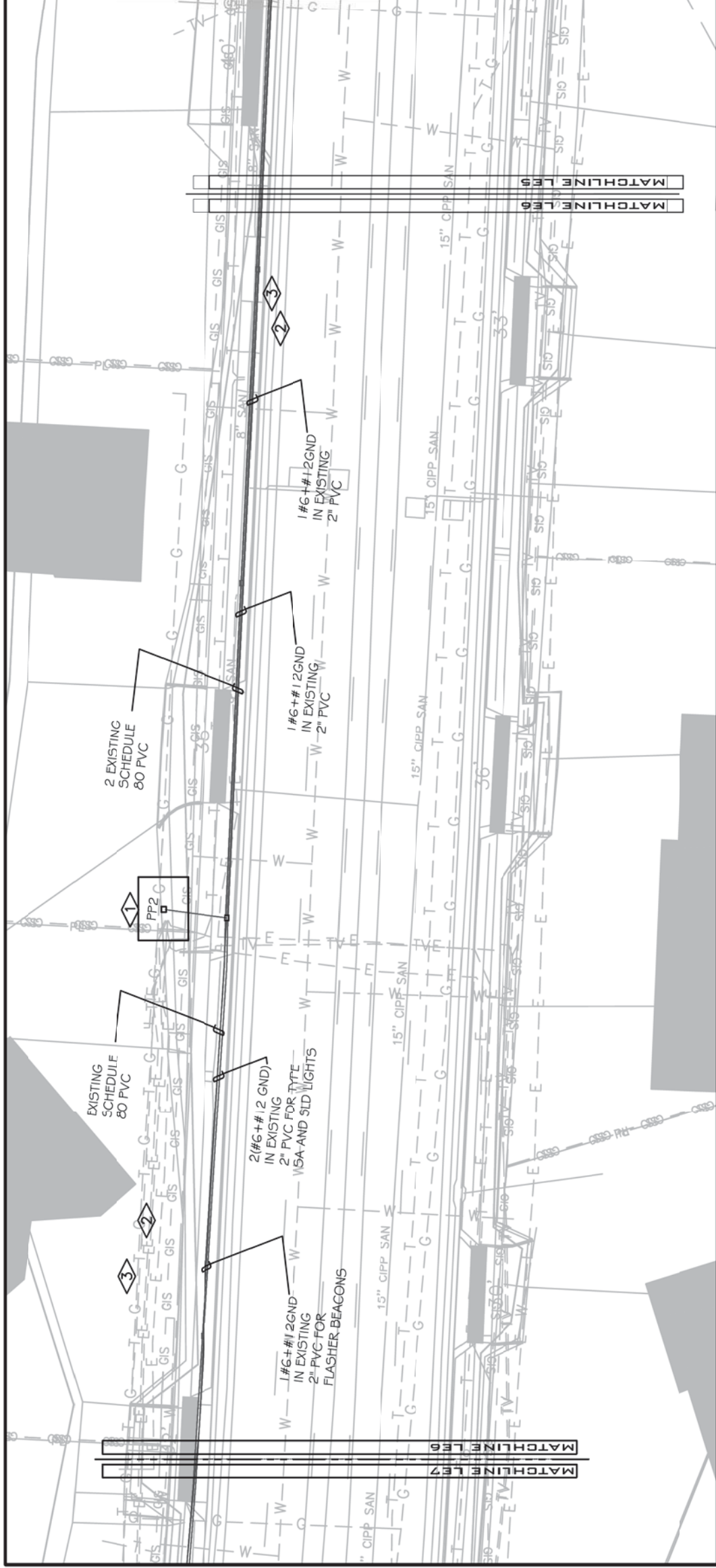

LIGHTING/ELECTRICAL PLAN

SCALE: 1"=40'

FLAG NOTES:

- ① PROVIDE NEW 100A 1 PHASE 208/120 VOLT MILBANK PEDESTAL PANEL. PANEL TO BE LOCATED NORTH OF EXISTING XCEL SWITCH CABINET, BETWEEN EXISTING HYDRANT AND SWITCH CABINET. FIELD VERIFY EXACT LOCATION OF PEDESTAL WITH EXCEL AND CLEARANCE TO EXISTING FIRE HYDRANT PRIOR TO ROUGH-IN. REFERENCE 'LOCATION OF NEW 100 AMP PEDESTAL PP2' DETAIL. SUPPLY PHOTOCELL TO PEDESTAL AND POSITION PEDESTAL SO THAT PHOTOCELL IS FACING NORTH, TYPICAL.
- ② PROVIDE (1#6+#12 GND) TO PEDESTRIAN LIGHTS TYPE 'SA' AND STREET LIGHT TYPE 'SLD'. CIRCUIT TO NEW 20 AMP 208 VOLT SWITCHED BREAKER IN NEW PEDESTAL PP2 .
- ③ PROVIDE (1#6+#12 GND) TO RECTANGULAR RAPID FLASHING BEACON SYSTEM LIGHTS. CIRCUIT TO NEW UNSWITCHED 20 AMP 120 VOLT CIRCUIT BREAKER IN PEDESTAL PP2.



ACM CONSULTING
 ELECTRICAL DESIGN CONSULTING
 ENGINEERS: PH: 970-245-7292
 PO. 3211 GRAND JCT, CO. 81502
 EMAIL: joalm@acmengr.com

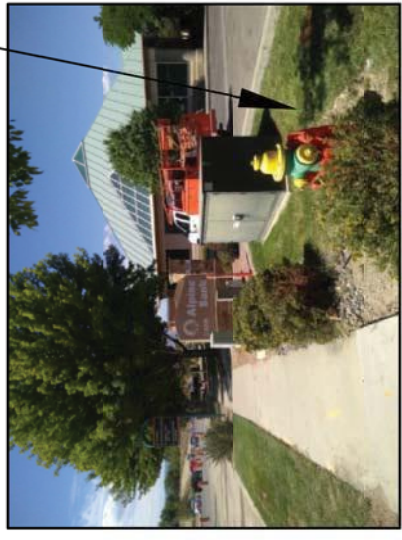

LOCATION OF NEW 100 AMP PEDESTAL PP2
 DETAIL

Colorado Department of Transportation 606 South 9th Street Grand Junction, CO, 81501 Phone: 970-683-6351 FAX: 970-683-6369 Region 3	Sheet Revisions		As Constructed		Project No./Code SHO M555-033
	Date:	Comments	Init.	No Revisions:	
City of Grand Junction COLORADO 333 West Ave. Grand Junction, CO, 81501 Phone: 970-244-1554	HORIZON DRIVE CROSSWALK PANEL LOCATION PLAN		No Revisions: Revised: Void:		Structure Numbers: 22497 Subset Sheets: 6 of 11
	SHY		LE6		50

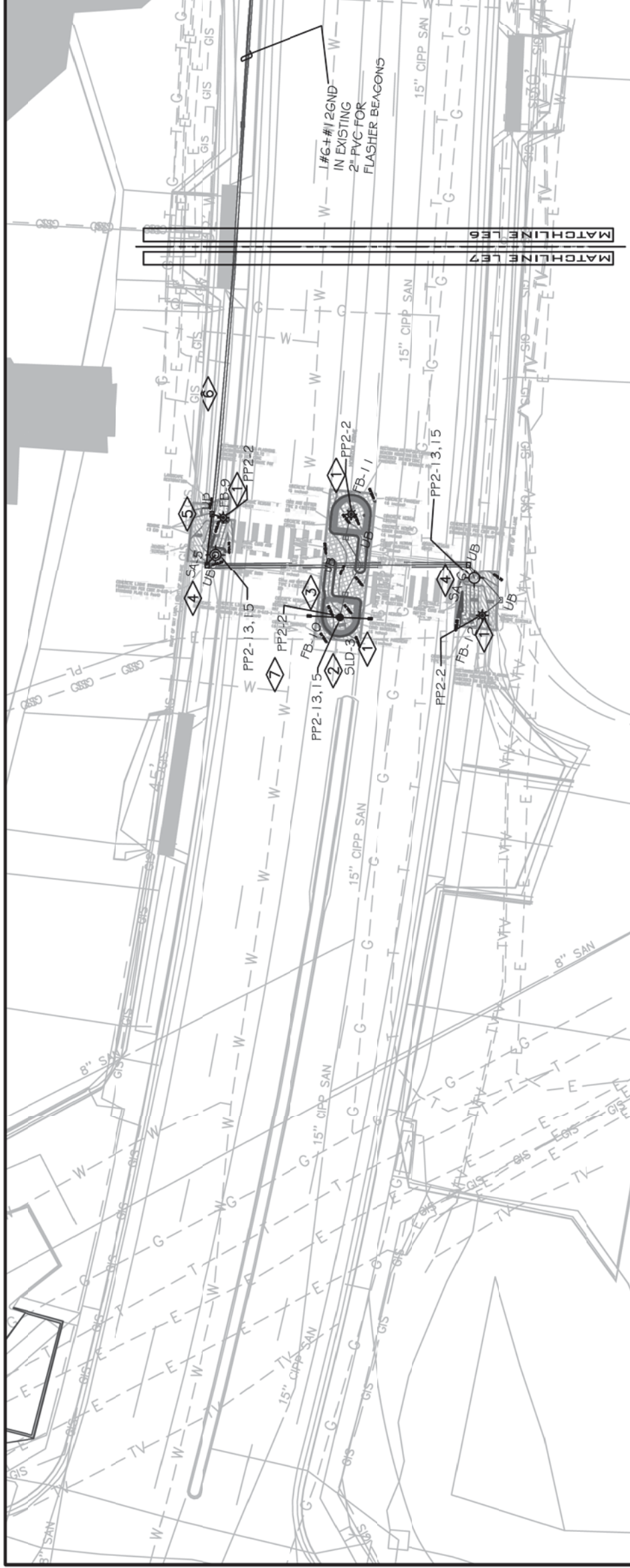

LIGHTING/ELECTRICAL PLAN



SCALE: 1"=30'

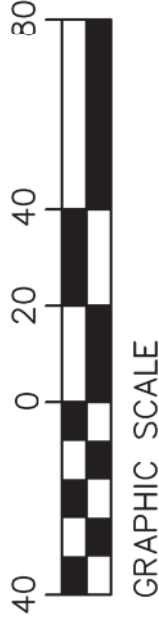

FLAG NOTES:

- 1 WIRE NEW RECTANGULAR RAPID FLASHING BEACON SYSTEM TO NEW 120 VOLT 20 AMP CIRCUIT IN NEW PANEL PP2. FIELD VERIFY EXACT LOCATION WITH OWNER AND COORDINATE INSTALLATION WITH PROVIDER PRIOR ROUGH-IN.
- 2 WIRE NEW DOUBLE ARM 30' LIGHT POLE TYPE SLD TO NEW 240 VOLT 20 AMP 2-POLE CIRCUIT. CIRCUIT TO BE SWITCHED ON AND OFF AT CABINET.
- 3 NEW RECTANGULAR RAPID FLASHING BEACON SYSTEM 'FB-10' TO BE MOUNTED TO LIGHT POLE. COORDINATE INSTALLATION WITH PROVIDER PRIOR TO ROUGH-IN.
- 4 WIRE NEW PEDESTRIAN LIGHTS TO NEW 20 AMP 208 VOLT 2-POLE CIRCUIT IN PANEL PP2.
- 5 STUB UP EMPTY 2" CONDUIT IN JBOX, PROVIDE PULL STRING AND PLUGS. CIRCUIT TO BE SWITCHED ON AND OFF AT CABINET.
- 6 WIRING TO BE (#6 THWN CU + #12 GND) UNLESS OTHERWISE NOTED.
- 7 EACH TYPE 'SA' AND 'SLD' TYPE FIXTURES TO HAVE TYPE 1 PULL BOX, TYPICAL.

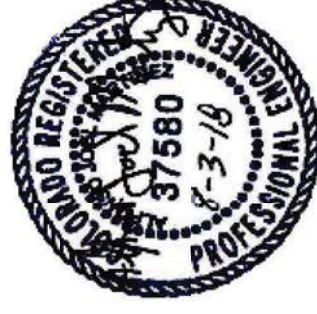

Know what's below.
Call before you dig.

ACM CONSULTING
ELECTRICAL DESIGN CONSULTING
ENGINEERS: PH: 970-245-7292
PO. 3211 GRAND JCT. CO. 81502
EMAIL: joalm@acmengr.com

Colorado Department of Transportation

606 South 9th Street
Grand Junction, CO, 81501
Phone: 970-683-6351 FAX: 970-683-6369
Region 3



333 West Ave. Grand Junction, CO, 81501 Phone: 970-244-1554

As Constructed

No Revisions:
Revised:
Void:

HORIZON DRIVE SOUTH CROSSWALK LIGHTING PLAN

Designer: JCS
Detailer: JCS
Structure Numbers
Sheet Subset: General
Subst Sheets: 7 of 11

Project No./Code

SHO M555-033
22497
LE7
51

EXISTING PAD MOUNTED
TRANSFORMER 50KVA
240/120 VOLT, 1PH

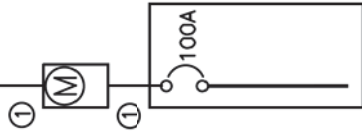

EXISTING PP1 100A
240/120V 1PH, 3W
22 KAIC

CABLE LEGEND

① 1 SET(S)[2" PVC SCHED. 80 (3#3(CU,THWN)+1#8(CU)GND]

ONE-LINE DIAGRAM
NOT TO SCALE

EXISTING PAD MOUNTED
TRANSFORMER 300KVA
208/120 VOLT, 1PH

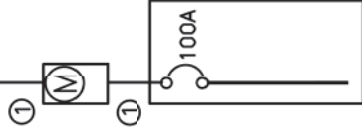

NEW PP2 100A MCB
24CKT 12 SWITCHED
12 UN-SWITCHED
208/120V 1PH, 3W
22 KAIC

CABLE LEGEND

① 1 SET(S)[2" PVC SCHED. 80 (3#3(CU,THWN)+1#8(CU)GND]

ONE-LINE DIAGRAM
NOT TO SCALE

GENERAL NOTES:

1. IN AS MUCH AS DESIGN REQUIRES THAT CERTAIN ASSUMPTIONS BE MADE REGARDING EXISTING CONDITIONS, AND BECAUSE SOME OF THESE ASSUMPTIONS CANNOT BE VERIFIED, FIELD COORDINATION DURING CONSTRUCTION SERVICES IS IMPERATIVE. CONTRACTORS BIDDING THIS WORK MUST MAKE REASONABLE ALLOWANCES FOR UNFORESEEN CONTINGENCIES.
2. THE SERVING ELECTRICAL ASSOCIATION SHALL ADVISE THE OWNER/ENGINEER PRIOR TO SERVICE MODIFICATION REQUIRING COST TO THE OWNER.
3. REFERENCE CIVIL, LANDSCAPE AND IRRIGATION DRAWING PLANS FOR COORDINATION AND LOCATION OF ALL UNDER GROUND SYSTEMS.
4. ALL WORK SHALL BE COORDINATED WITH OTHER TRADES AS REQUIRED: REFERENCE CIVIL LANDSCAPE AND IRRIGATION DRAWINGS.
5. ALL WIRING IS SHOWN DIAGRAMMATICALLY ON DRAWINGS. FIELD VERIFY ALL CONDITIONS PRIOR TO ROUGH-IN.
6. ALL ELECTRICAL WORK SHALL COMPLY WITH THE LATEST EDITION OF NATIONAL ELECTRICAL CODE AND ALL APPLICABLE LOCAL CODES.
7. ALL NEW BRANCH CIRCUITS TO BE #6 THWN CU UNLESS NOTED OTHERWISE.
8. CONDUCTOR COUNT IS SHOWN FOR REFERENCE ONLY. CONTRACTOR SHALL INSURE THAT ANY AND ALL DEVICES AND EQUIPMENT ARE CIRCUITED PROPERLY. CONTRACTOR SHALL ENSURE THAT NO EQUIPMENT OR DEVICES ARE COMBINED OTHER THAN WHAT IS DEPICTED.
9. FIELD VERIFY ALL DIMENSIONS, DO NOT SCALE DRAWINGS.
10. COORDINATE INSTALLATION OF METER AND ELECTRICAL REQUIREMENTS WITH XCEL ENERGY, FOR PANEL PP2.



Know what's below.
Call before you dig.



ACM CONSULTING
ELECTRICAL DESIGN, CONSULTING
ENGINEERS, PH: 970-245-7292
PO. 3211 GRAND, JCT., CO. 81502
EMAIL: joel@acmengr.com

Colorado Department of Transportation



606 South 9th Street
Grand Junction, CO, 81501
Phone: 970-683-6351 FAX: 970-683-6369
SHY

Sheet Revisions

Date:	Comments	Init.

CITY OF
Grand Junction
C O L O R A D O

333 West Ave. Grand Junction, CO, 81501 Phone: 970-244-1554

As Constructed

No Revisions:	
Revised:	
Void:	

**HORIZON DRIVE CROSSWALK
ELECTRICAL DETAILS, ONE-LINE**

Designer:	JCS	Structure	
Detailer:	JCS	Numbers	22497
Sheet Subset:	General	Subset Sheets:	8 of 11
			LEB
			52

Project No./Code

	SHO M555-033

NOTES PEDESTAL PP2

- MILBANK - CATALDQ NO. CP3BSJH22CSSL, CONTROL CABINET SHALL BE U/L LISTED "INDUSTRIAL CONTROL PANEL" PER UL 508.
- CONSTRUCTION SHALL BE NEMA 3R, 12 GA. A60 STEEL POWDER COATED MINT GREEN WITH PHOTO ELECTRIC CELL IN SERVICE CABINET. ELECTRICAL CONTRACTOR TO PROVIDE PHOTOCELL.
- VOLTAGE RATINGS OF SERVICE EQUIPMENT SHALL CONFORM TO THE SERVICE VOLTAGES INDICATED ON THE PLANS.
- SERVICE EQUIPMENT ENCLOSURE AND METERING EQUIPMENT SHALL MEET THE REQUIREMENTS OF THE SERVING UTILITY. WHEN THE SERVING UTILITY PROVIDES BOTH METERED AND UNMETERED CIRCUITS, A SEPARATE BUS SHALL BE PROVIDED FOR EACH CIRCUIT. THE METER AREA SHALL HAVE A SEALING, LOCKABLE, RAIN TIGHT COVER THAT CAN BE REMOVED WITHOUT THE USE OF TOOLS.
- SERVICE EQUIPMENT SHALL BE FACTORY WIRED AND CONFORM TO NEMA STANDARDS.
- THE EXTERIOR DOOR SHALL HAVE PROVISIONS FOR PADLOCKING. THE PADLOCK HOLE SHALL BE A MINIMUM DIAMETER OF 11mm.
- ALL TERMINALS FOR INCOMING SERVICE CONDUCTORS SHALL BE COMPATIBLE WITH EITHER COPPER OR ALUMINUM CONDUCTORS SIZED TO SUIT THE CONDUCTORS SHOWN ON THE PLAN. TERMINAL LUGS SHALL BE COPPER OR TIN-PLATED ALUMINUM. SOLID NEUTRAL TERMINAL STRIP SHALL BE RATED 125A UNLESS OTHERWISE SPECIFIED AND FOR USE WITH COPPER OR ALUMINUM CONDUCTORS. THE TERMINAL SHOULD INCLUDE BUT NOT BE LIMITED TO:
 - INCOMING TERMINALS (LANDING LUGS)
 - NEUTRAL LUGS
 - SOLID NEUTRAL TERMINAL STRIP
 - TERMINAL STRIPS FOR CONDUCTORS WITHIN THE ENCLOSURE.
- AT LEAST 4 STANDARD SINGLE POLE 240V AND 1 SINGLE POLE 120 CIRCUIT BREAKER SPACES (20mm NOMINAL) SHALL BE PROVIDED FOR BRANCH CIRCUITS. CIRCUIT BREAKER INTERIORS SHALL BE COPPER. INTERIORS SHALL ACCEPT PLUG-IN OR CABLE-IN/ CABLE-OUT CIRCUIT BREAKERS.
- PLUG-IN CIRCUIT BREAKERS MAY BE MOUNTED IN THE VERTICAL OR HORIZONTAL POSITION. CABLE-IN/ CABLE-OUT CIRCUIT BREAKERS SHALL BE MOUNTED IN THE VERTICAL POSITION.
- FASTENERS ON THE EXTERIOR OF THE ENCLOSURE SHALL BE VANDAL RESISTANT AND SHALL NOT BE REMOVABLE FROM THE EXTERIOR. ALL NUTS, BOLTS, SCREWS, WASHERS, AND HINGES SHALL BE STAINLESS STEEL.
- PHENOLIC NAME PLATES SHALL BE PROVIDED AS REQUIRED.
- A PLASTIC COVERED WIRING DIAGRAM SHALL BE ATTACHED TO THE INSIDE OF THE FRONT DOOR.
- FOUNDATION SHALL EXTEND 50mm MINIMUM BEYOND EDGE OF ENCLOSURE.

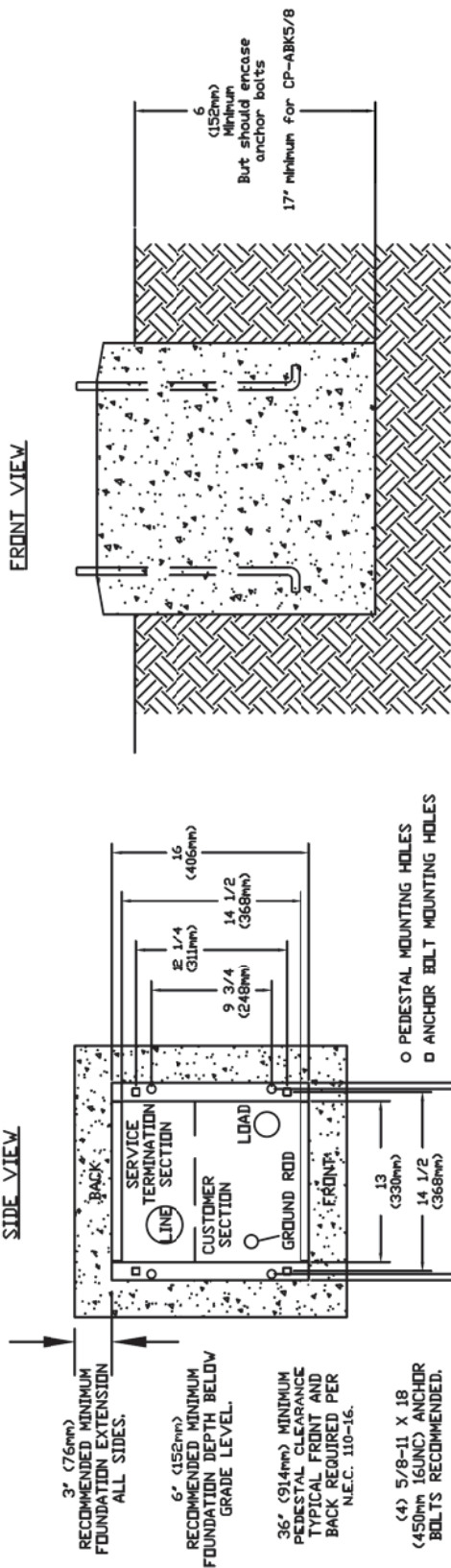
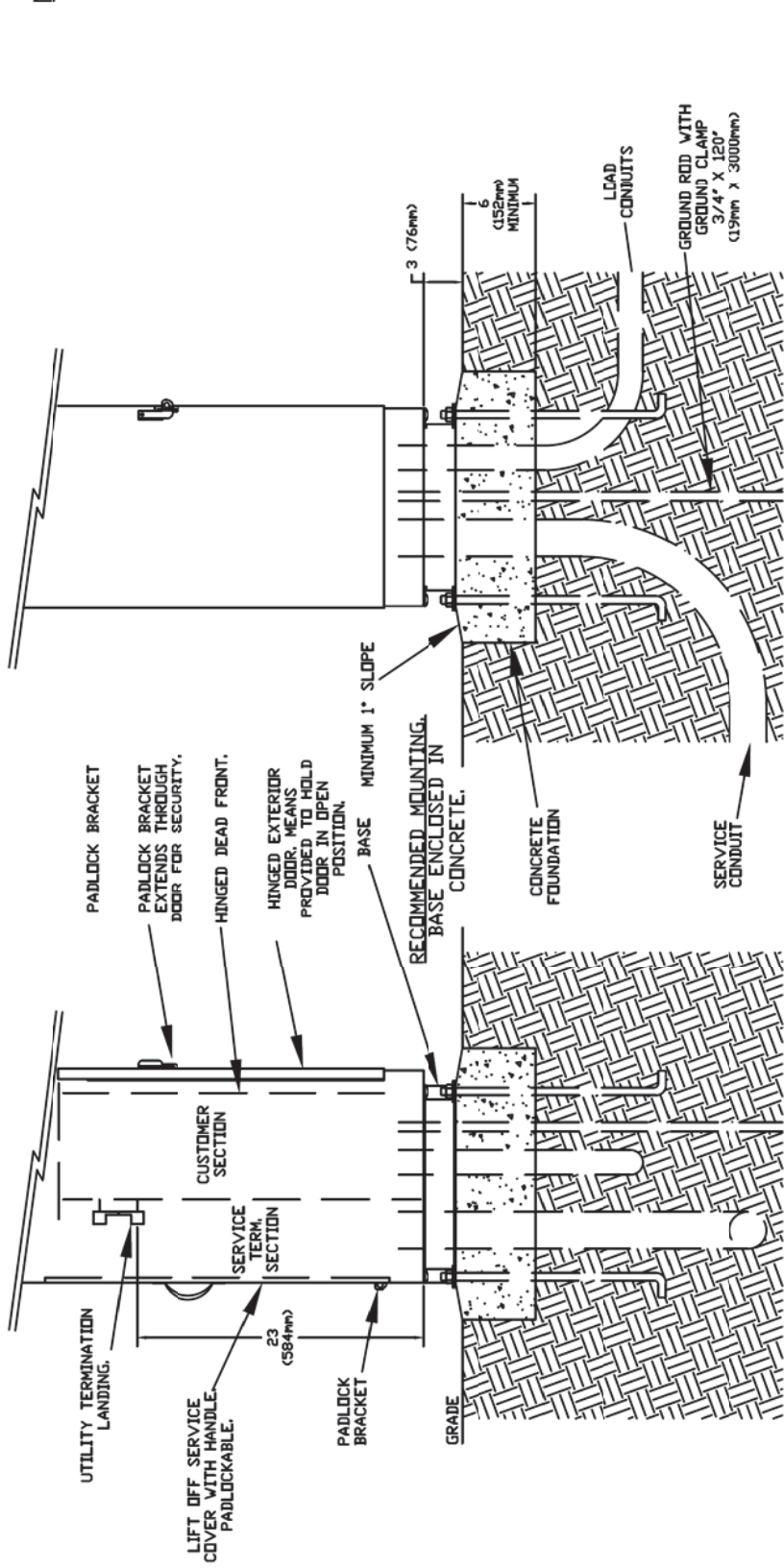

(B) TYPICAL POWER PEDESTAL/LIGHTING CONTROL CENTER (SPECIAL) PLAN
 (I) NOT TO SCALE



Know what's below.
Call before you dig.

ACM CONSULTING
 ELECTRICAL DESIGN CONSULTING
 ENGINEERS: PH: 970-245-7282
 PO. 3211 GRAND JCT. CO. 81502
 EMAIL: joalm@ACMengrs.com

Colorado Department of Transportation 606 South 9th Street Grand Junction, CO, 81501 Phone: 970-683-6351 FAX: 970-683-6369 SHY	Sheet Revisions		As Constructed		POWER/LIGHTING PEDESTAL CONTROL CONTROL CENTER DETAILS		Project No./Code	
	Date:	Comments	Init.	No Revisions:	Designer: JCS	Structure Numbers	SHO M555-033	
				Revised:	Detailer: JCS		22497	
				Void:	Sheet Subset: General	Subset Sheets: 9 of 11	LE9	
								53

CITY OF Grand Junction
 COLORADO
 333 West Ave. Grand Junction, CO, 81501 Phone: 970-244-1554

TYPICAL PEDESTRIAN LIGHT



1. EACH INSTALLED AND FUTURE LIGHT LOCATION TO HAVE PULL BOX
2. COIL 10 OF WIRE FOR CONNECTION TO FUTURE LIGHTING

UTILITY BOX CONNECTION DETAIL

NOT TO SCALE

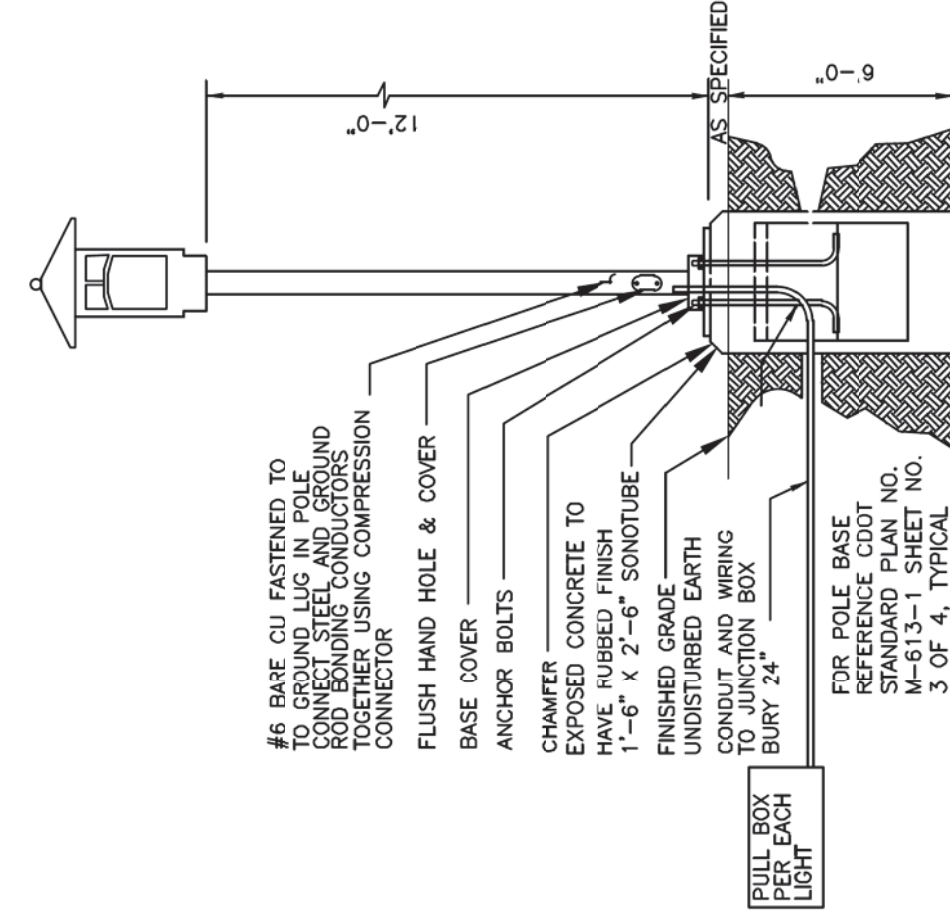

TYPICAL TYPE "SA" DETAIL

NOT TO SCALE

POLE DETAIL NOTES:

1. ORDER 5" SQUARE POLES. POLES TO USE 11" BOLT CIRCLES. OBTAIN POLE MOUNTING TEMPLATE PATTERN FROM MANUFACTURER PRIOR TO ROUGH-IN.
2. PROVIDE EACH PEDESTRIAN LIGHT INSTALLED IN THIS CONTRACT WITH J-BOX.
3. ELECTRICAL CONTRACTOR TO ORDER ALL REQUIRED HARDWARE FOR MOUNTING OF EACH LUMINARIES.
4. REFERENCE CDOT STANDARD PLAN NO. M-613-1 FOR INSTALLATION DETAILS, TYPICAL.
5. NOTIFY ENGINEER OF ANY OBSTRUCTIONS TO POLE PLACEMENT IMMEDIATELY BEFORE PROCEEDING.
6. VERIFY REQUIRED VOLTAGE OF FOR EACH LUMINARIES WITH AVAILABLE VOLTAGES PRIOR TO ORDERING.

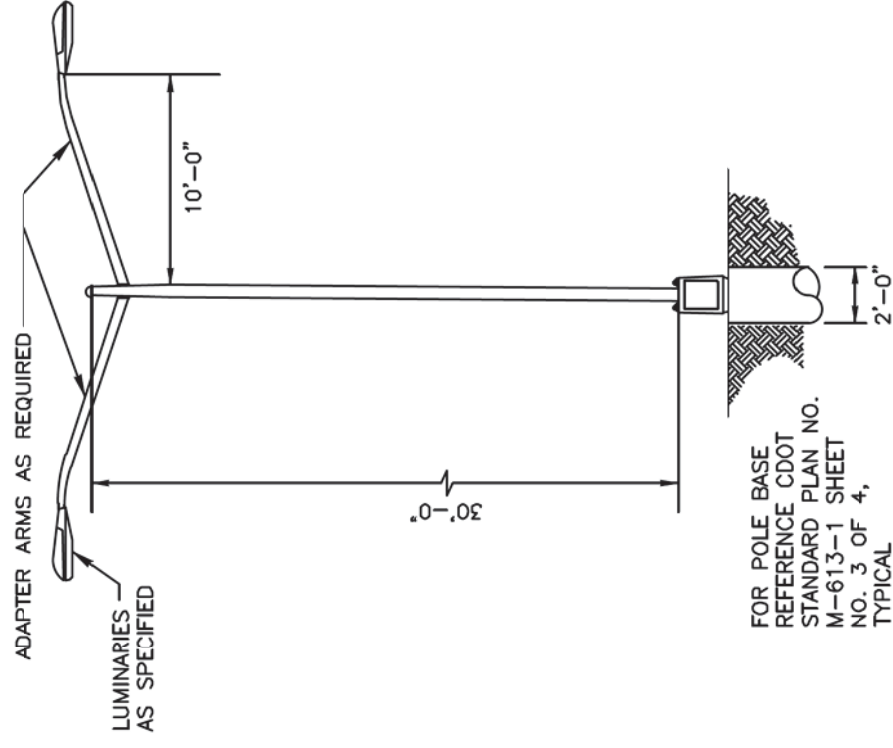

TYPICAL TYPE "SLD" DETAIL

NOT TO SCALE

TYPE	MANUFACTURER MODEL NUMBER	APPROVAL	VOLTAGE MOUNTING # OF LAMPS	LUMINAIRE SCHEDULE SCULPTURE	
				BALLAST LAMPE TYPE WATTS	DESCRIPTION
SA	STERNBERG LIGHTING 1220LEDPT/S4 PT/SSQ14/4MR35T3ML/WV/BKT	OWNER REQUESTED	240 POLE 1	ELECTRONIC LED 95	PEDESTRIAN LUMINAIRE, POST TOP MOUNTED, LED, CUTOFF, ORDER POLE SO THAT LAMP HEIGHT IS 12' AFG MEASURED AT BOTTOM OF LUMINAIRE
SLD	GEL LIGHTING ERS/LH-0-15-E1-40-D-GRAY035 XCEL	OWNER REQUESTED	240 POLE 2	ELECTRONIC LED 322W	DUAL ARM(10' EACH AT 180 DEGREES) MOUNTED STREET LUMINAIRE, LED, CUTOFF, ORDER POLE HEIGHT SO THAT LAMP HEIGHT IS 30' AFG MEASURED AT BOTTOM OF LUMINAIRE.



Know what's below. Call before you dig.

ACM CONSULTING
 PHYSICAL DESIGN CONSULTING
 ENGINEERS: PH: 970-244-7700
 PO. 3211 GRAND JCT. CO. 81502
 EMAIL: joelm@acmengr.com

Colorado Department of Transportation

606 South 9th Street
 Grand Junction, CO, 81501
 Phone: 970-683-6351 FAX: 970-683-6369

Region 3

SHY

Sheet Revisions

Date:	Comments	Init.

CITY OF Grand Junction COLORADO

333 West Ave. Grand Junction, CO, 81501 Phone: 970-244-1554

As Constructed

No Revisions:	
Revised:	
Void:	

POWER/LIGHTING PEDESTAL CONTROL CENTER DETAILS

Designer:	JCS	Structure Numbers	
Detailer:	JCS		
Sheet Subset:	General	Subset Sheets:	10 of 11

Project No./Code

SHO M555-033

22497

LE10 54

