

DATE SUBMITTED: 5/7/90

PERMIT # \_\_\_\_\_

FEE 5.00

# SIGN PERMIT

GRAND JUNCTION PLANNING DEPARTMENT

BUSINESS NAME: Jim Fuoco Mitsubishi ✓

BUSINESS ADDRESS: 748 North First

STREET FRONTAGE: FRONT \_\_\_\_\_ FT. SIDE \_\_\_\_\_ FT.

BUILDING FRONTAGE: First FRONT 125' FT. 92.00 SIDE 100' FT.

TRAFFIC LANE: FRONT 4 FT. SIDE 2 FT.

HEIGHT OF SIGN: 16.5' FT. CLEARANCE TO GRADE: 10' FT.

AREA OF SIGN: 22.5 ~~sq~~ 20' SQ. FT. AREA OF EXISTING SIGNS: 226 SQ. FT.

TOTAL ALLOWED AREA: FRONT 250 SQ. FT. SIDE \_\_\_\_\_ SQ. FT.

### TYPE OF SIGN

- ON PREMISE
- OFF PREMISE
- FREE STANDING
- PROJECTING
- ROOF
- FLUSH WALL
- ILLUMINATED
- OTHER

COMMENTS D/P

### \*SKETCH

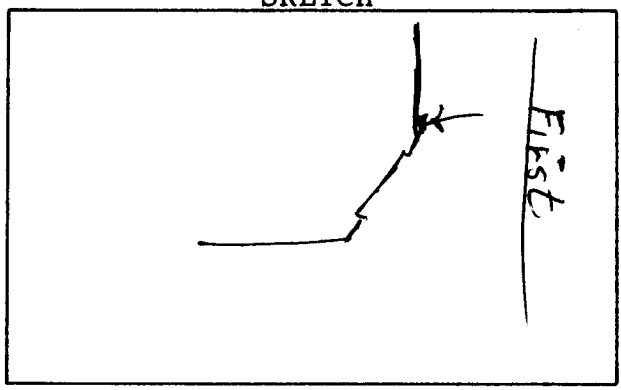

\*Include: Streets, Property Lines, Proposed Sign Location.

PROPERTY OWNER: Jim Fuoco

ADDRESS: 748 North First

CONTRACTOR: Western Neon Co.

ADDRESS: 2483 Commerce Blvd.

PHONE: 242-7843

Jim Cook  
Signature

APPROVED BY: Kurt Metzger  
DATE APPROVED: 5/7/90

- FINAL PERMIT
- WILL REQUIRE SEPARATE PERMIT  
Electric

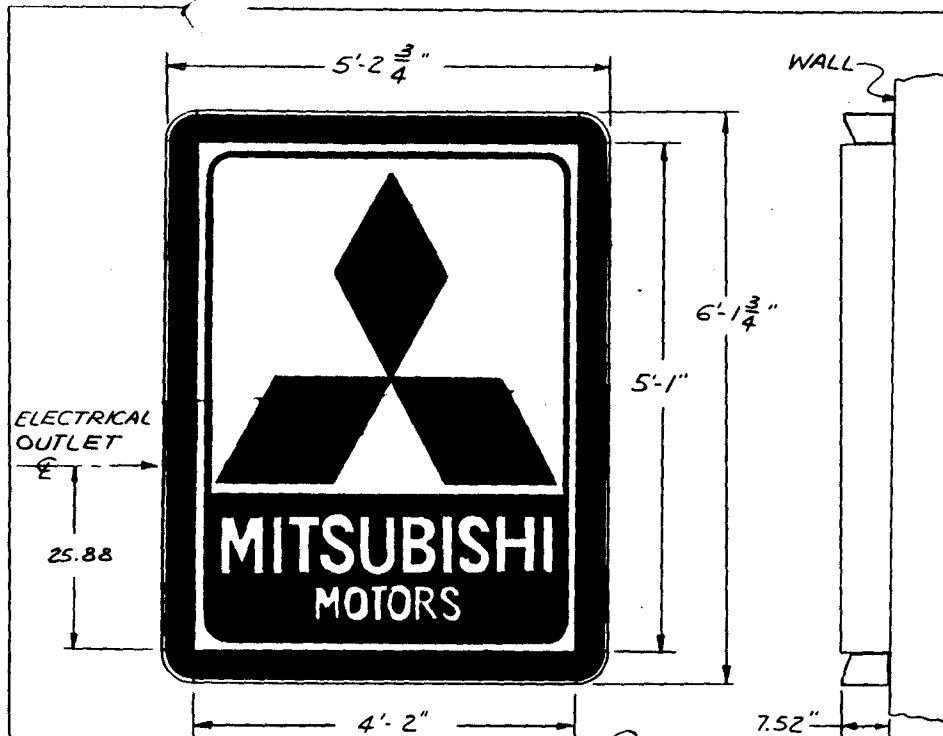

**SPECIFICATIONS**

1. LAMPS: (4) F60 T12
2. BALLAST: (1) # 256-472-100 OR EQL.
3. CIRCUITS: (1) 20 AMP @ 120V, 60 HZ.
4. TOTAL CONN. LOAD: 3.0 AMPS MAX.
5. WIND LOAD: 30 PSF
6. SERVICE SIGN: SLIDE FACE.
7. SIGN WEIGHT: UNCRATED 127 LBS.  
CRATED 170 LBS.

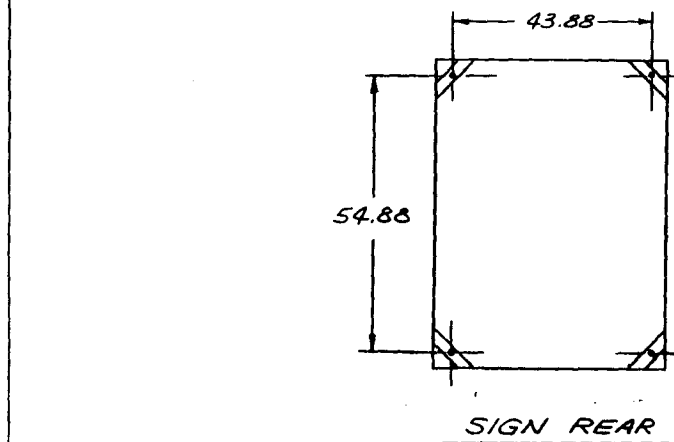

**NOTE:**  
INSTALLER TO SUPPLY APPROPRIATE  
WALL ANCHORS

**MOUNTING HARDWARE**

- 1/2" BOLTS THROUGH WALL
- 1/2" LAG BOLTS W/LEAD SHIELDS
- 1/2" LAG BOLTS
- 1/2" TOGGLE BOLTS

**BUILDING CONSTRUCTION**

MASONRY	WOOD	METAL
X	X	X
YELLOW BLOCK ONLY		X

INST'N & FND'N  
ENG'G # 002-4307

A	3101	12-20-89
RTB	REL TO PROJ	
REV.	ECN	DATE

**Plasti-Line, Inc.**

823 E. Emory Road  
P.O. Box 5066 Knoxville, TN 37928-0066

DSG'NR:	DATE:	SCALE: ~
DWG. BY: LT	DATE: 7/6/87	APP'D BY: [Signature]
CH'K BY:	DATE:	DATE: 8/6/87
DESC: INSTALLATION MITSUBISHI 5'x4' S.F. W.F. SIGN		
CUSTOMER: MITSUBISHI		
SHEET 1 OF 3	DRAWING NO. B 04731	

PROPERTY OF PLASTI-LINE, INC.  
NOT TO BE DUPLICATED.