



SIGN PERMIT

Community Development Department
250 North 5th Street
Grand Junction, CO 81501
(303) 244-1430

PERMIT NO. _____
Date Submitted 5-10-97
FEE \$ 20.00
Tax Schedule: 2995-129-00-019
Zone: C-1

BUSINESS NAME auto mart of jf CONTRACTOR Canvas Products Co
STREET ADDRESS 2122 north ave ADDRESS 588 25 Road
PROPERTY OWNER Royce Carville TELEPHONE NO 242-1453
OWNER ADDRESS 2195 Main Delta Co LICENSE NO 2990281

- 1. FLUSH WALL 2 Square Feet per Linear Foot of Building Facade
- 2. ROOF 2 Square Feet per Linear Foot of Building Facade
- 3. FREE-STANDING 2 Traffic Lanes - 0.75 Square Feet x Street Frontage
4 or more Traffic Lanes - 1.5 Square Feet x Street Frontage
- 4. PROJECTING 0.5 Square Feet per Each Linear Foot of Building Facade
- 5. OFF-PREMISE See #3 Spacing Requirements; Not > 300 Square Feet or < 15 Square Feet

Externally Illuminated Internally Illuminated Non-Illuminated

- (1 - 5) Area of Proposed Sign 130 Square Feet *(3 signs on awnings)*
- (1,2,4) Building Facade 200/69 Linear Feet
- (1 - 4) Street Frontage 330 Linear Feet
- (2,4,5) Height to Top of Sign 12 Feet Clearance to Grade _____ Feet
- (5) Distance from all Existing Off-Premise Signs within 600 Feet _____ Feet

Existing Signage/Type

<u>None</u>	_____	Sq Ft
_____	_____	Sq Ft
_____	_____	Sq Ft
Total Existing:	<u>0</u>	Sq Ft

FOR OFFICE USE ONLY:

Signage Allowed on Parcel

Building	<u>338</u>	Sq Ft
Free-Standing	<u>450</u>	Sq Ft
Total Allowed:	<u>450</u>	Sq Ft

COMMENTS: All existing signs will be removed

NOTE: No sign may exceed 300 square feet. A separate sign permit is required for each sign. Attach a sketch of proposed and existing signage including types, dimensions, lettering, abutting streets, alleys, easements, property lines, and locations. All signs require a separate permit from the Building Department.

<u>[Signature]</u>	<u>5-10-97</u>	<u>[Signature]</u>	<u>5/24/97</u>
Applicant's Signature	Date	Approved By	Date

Canvas Products Co.

Auto MART of GJ
2122 North Ave
Rouce Carville
874-7577

#1

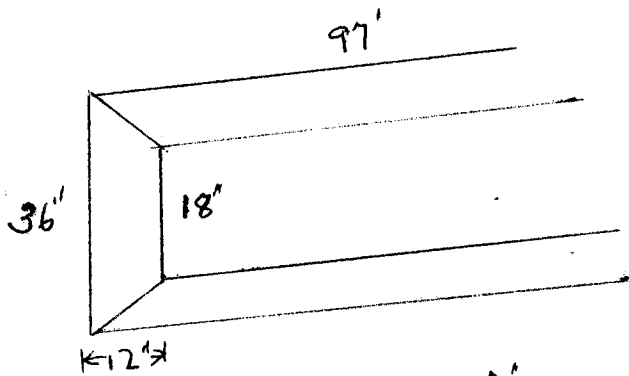

Signage 16' x 10'
x 2 = 15 sq. ft. x 2

#2

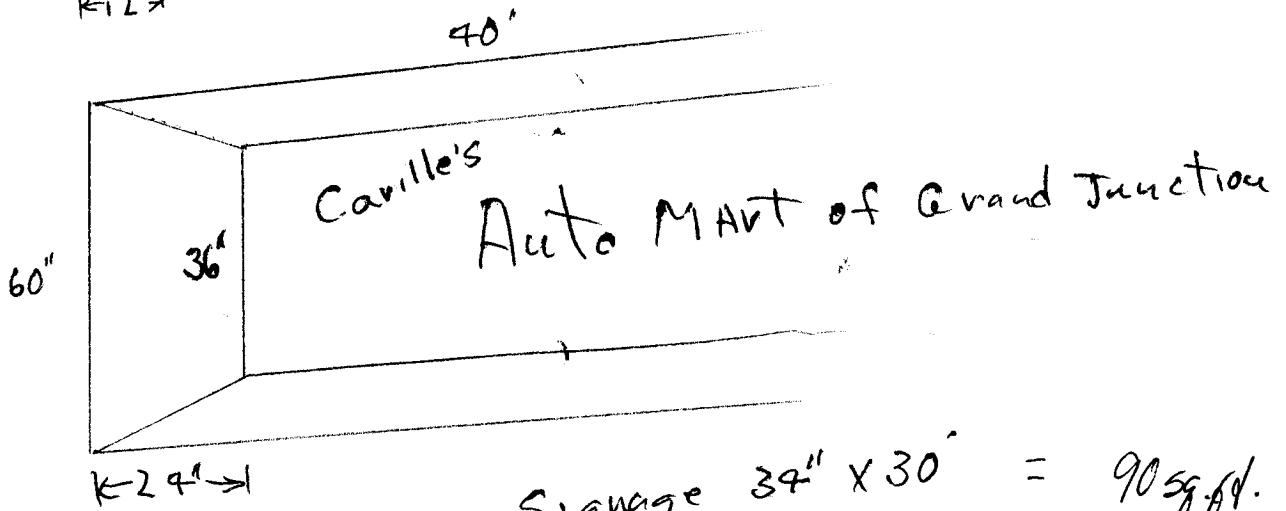

Signage 34' x 30' = 90 sq. ft.

ACCEPTED *RP 5/24/94*
ANY CHANGE OF SETBACKS MUST BE
APPROVED BY THE CITY PLANNING
DEPT. IT IS THE APPLICANT'S
RESPONSIBILITY TO PROPERLY
LOCATE AND IDENTIFY EASEMENTS
AND PROPERTY LINES.

Tom Dykstra

588 25 Road • Grand Junction, CO 81505 • (303) 242-1453