



SIGN PERMIT

Community Development Department
250 North 5th Street
Grand Junction, CO 81501
(303) 244-1430

PERMIT NO. _____
Date Submitted 1/31/96
FEE \$ 25100
Tax Schedule 2945-153-03-010
Zone C-1

BUSINESS NAME DOS HOMBRES
STREET ADDRESS 421 BRACH DR.
PROPERTY OWNER SCOTT HOWARD
OWNER ADDRESS G JCT, CO

CONTRACTOR VALLEY SIGNS, INC.
LICENSE NO 2930660
ADDRESS 1008 3RD AVE.
TELEPHONE NO 970-245-8290

- 1. FLUSH WALL 2 Square Feet per Linear Foot of Building Facade
- 2. ROOF 2 Square Feet per Linear Foot of Building Facade
- 3. FREE-STANDING 2 Traffic Lanes - 0.75 Square Feet x Street Frontage
4 or more Traffic Lanes - 1.5 Square Feet x Street Frontage
- 4. PROJECTING 0.5 Square Feet per each Linear Foot of Building Facade
- 5. OFF-PREMISE See #3 Spacing Requirements; Not > 300 Square Feet or < 15 Square Feet

Externally Illuminated Internally Illuminated Non-Illuminated

- (1 - 5) Area of Proposed Sign 48 Square Feet
- (1,2,4) Building Facade 85' X 120' Linear Feet
- (1 - 4) Street Frontage 360' X 360' Linear Feet Hwy. 340 Frontage
- (2,4,5) Height to Top of Sign 13' 9" Feet Clearance to Grade 8 Feet
- (5) Distance from all Existing Off-Premise Signs within 600 Feet _____ Feet

Existing Signage/Type
4' X 8' FREESTANDING 32 Sq Ft
 _____ Sq Ft
 _____ Sq Ft
 Total Existing: 32 Sq Ft

FOR OFFICE USE ONLY:
Signage Allowed on Parcel
 Building _____ Sq Ft
 Free-Standing 540 Sq Ft
 Total Allowed: 540 Sq Ft

COMMENTS: ABOVE TO BE REMOVED AND REPLACED WITH NEW SIGN

NOTE: No sign may exceed 300 square feet. A separate sign permit is required for each sign. Attach a sketch of proposed and existing signage including types, dimensions, lettering, abutting streets, alleys, easements, property lines, and locations. All signs require a separate permit from the Building Department.

Derry Criss 1/30/96 Larry Porter 1/31/96
 Applicant's Signature Date Approved By Date

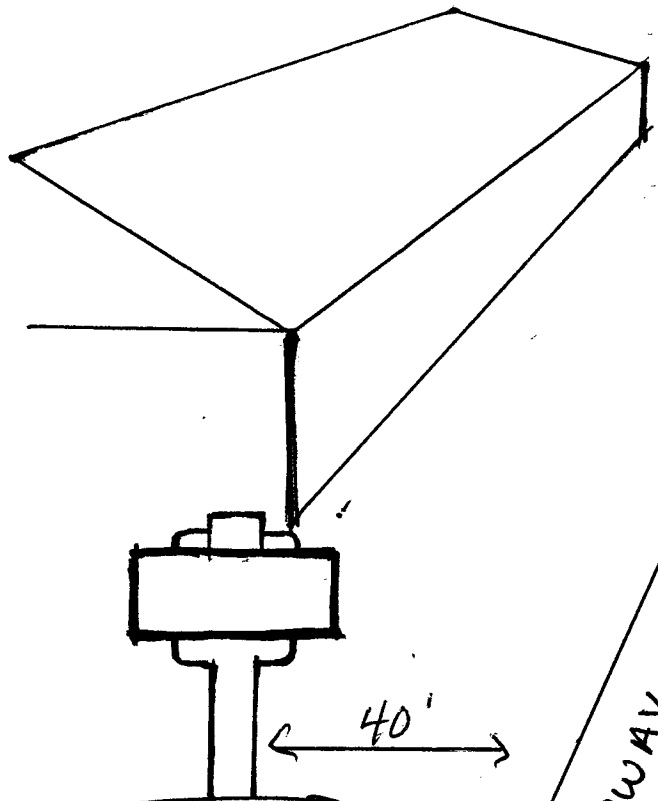

40'

BROADWAY

BRACH DR.

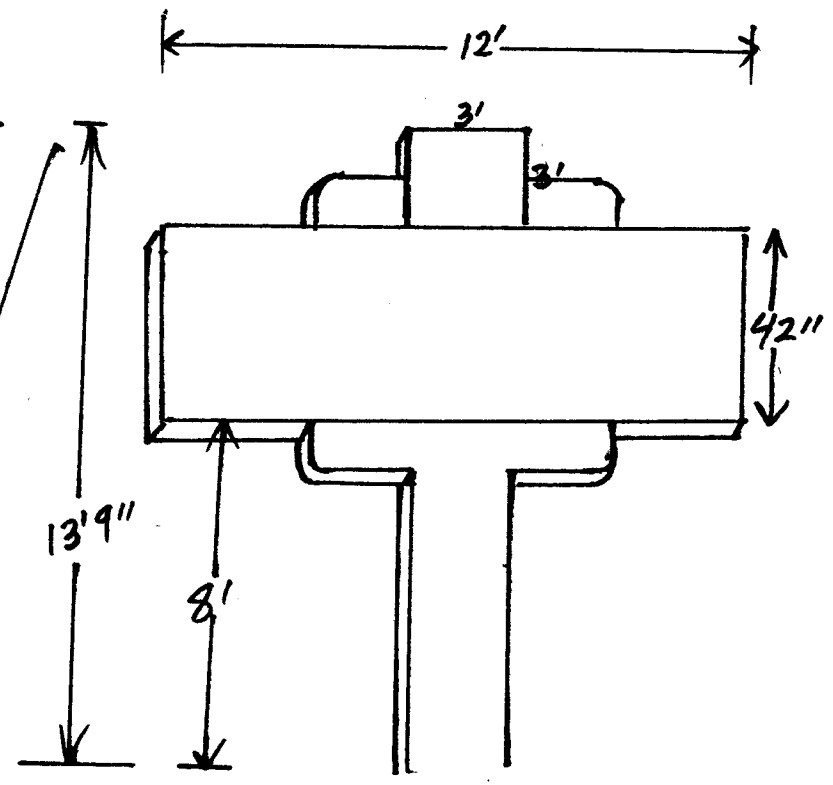

12'

3'

3'

42"

13'9"

8'

R-o-w is edge of pavement