



SIGN CLEARANCE



Community Development Department
 250 North 5th Street
 Grand Junction, CO 81501
 (970) 244-1430

Clearance No. 60599
 Date Submitted 8-13-97
 FEE \$ 25.00
 Tax Schedule 2945-143-15-021
 Zone B-3

BUSINESS NAME The Trophy Case
 STREET ADDRESS 131 North 4th St.
 PROPERTY OWNER Ron Mack
 OWNER ADDRESS same as above

CONTRACTOR Canvas Products Co
 LICENSE NO. 2950254 2970181
 ADDRESS 580 25 Road
 TELEPHONE NO. 242-1453

- 1. FLUSH WALL 2 Square Feet per Linear Foot of Building Facade
- 2. ROOF 2 Square Feet per Linear Foot of Building Facade
- 3. FREE-STANDING 2 Traffic Lanes - 0.75 Square Feet x Street Frontage
4 or more Traffic Lanes - 1.5 Square Feet x Street Frontage
- 4. PROJECTING 0.5 Square Feet per each Linear Foot of Building Facade
- 5. OFF-PREMISE See #3 Spacing Requirements; Not > 300 Square Feet or < 15 Square Feet

Externally Illuminated Internally Illuminated Non-Illuminated

- (1 - 5) Area of Proposed Sign 30 Square Feet
- (1,2,4) Building Facade 30 Linear Feet
- (1 - 4) Street Frontage 60 Linear Feet 60
- (2,4,5) Height to Top of Sign _____ Feet Clearance to Grade _____ Feet
- (5) Distance from all Existing Off-Premise Signs within 600 Feet _____ Feet

Existing Signage/Type:	
<u>None</u>	Sq. Ft.
	Sq. Ft.
	Sq. Ft.
Total Existing:	<u>0</u> Sq. Ft.

● FOR OFFICE USE ONLY ●		
Signage Allowed on Parcel:		
Building	<u>60</u>	Sq. Ft.
Free-Standing	<u>45</u>	Sq. Ft.
Total Allowed:	<u>60</u>	Sq. Ft.

COMMENTS: _____

NOTE: No sign may exceed 300 square feet. A separate sign clearance is required for each sign. Attach a sketch of proposed and existing signage including types, dimensions, lettering, abutting streets, alleys, easements, property lines, and locations. **A SEPARATE PERMIT FROM THE BUILDING DEPARTMENT IS REQUIRED.**

[Signature] 8-13-97 [Signature] 8/13/97
 Applicant's Signature Date Community Development Approval Date

(White: Community Development) (Canary: Applicant) (Pink: Building Dept) (Goldenrod: Code Enforcement)

Anvas Products Co
80 25 Road
Grand Junction, Co 81505
972-1453
Tom Dykstra

The Trophy Case
131 North 8th St
245-0984
Ron + Barbara + DAVID
MACK

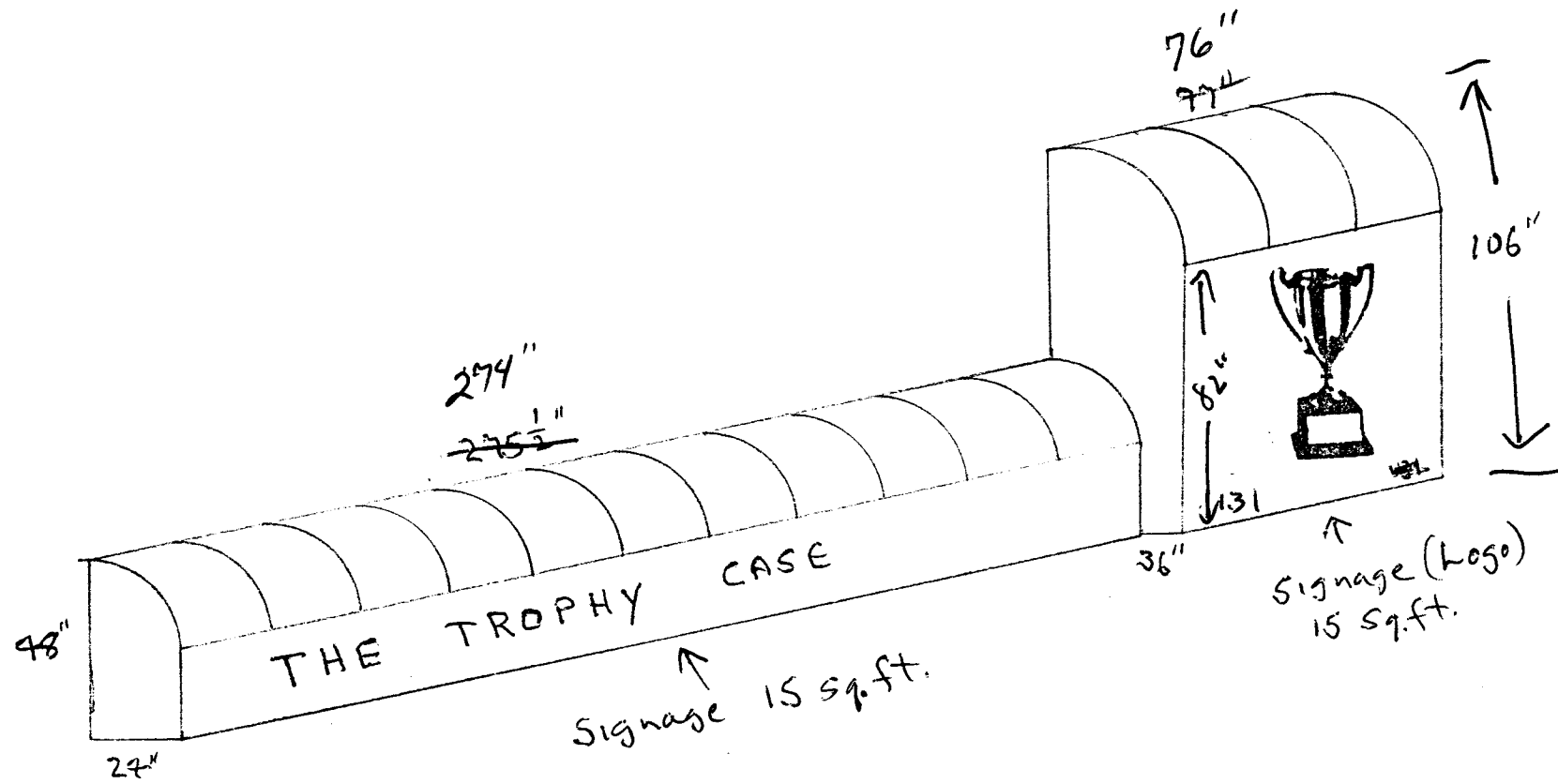

Andas Products Co
80 25 Road
D, Co 81505
2-1453
Tom Dykstra

Site Plan

The Trophy Case
131 North 4th St
GJ, Co 81501
Ron Mack
245-0989

