



SIGN PERMIT

Community Development Department
 250 North 5th Street
 Grand Junction, CO 81501
 (970) 244-1430

Permit No. _____
 Date Submitted 7-30-97
 FEE \$ 5.00
 Tax Schedule 2943-181-00-093
 Zone C-1

(E)

BUSINESS NAME Hilltop Community Resources LLC CONTRACTOR Western Neon Sign Co
 STREET ADDRESS 2897 NO AVE LICENSE NO. 2970446
 PROPERTY OWNER Hilltop Health Services Corp ADDRESS 2495 Industrial Blvd
 OWNER ADDRESS 1331 Hermosa TELEPHONE NO. 242-7843
Grand Jct Co. 81501

1. FLUSH WALL 2 Square Feet per Linear Foot of Building Facade
Face Change Only (2,3 & 4):
 2. ROOF 2 Square Feet per Linear Foot of Building Facade
 3. FREE-STANDING 2 Traffic Lanes - 0.75 Square Feet x Street Frontage
 4 or more Traffic Lanes - 1.5 Square Feet x Street Frontage
 4. PROJECTING 0.5 Square Feet per each Linear Foot of Building Facade

Existing Externally or Internally Illuminated - No Change in Electrical Service Non-Illuminated

- (1 - 4) Area of Proposed Sign 21.5 Square Feet 29 Rd
 (1,2,4) Building Facade 249 Linear Feet
 (1 - 4) Street Frontage 841 Linear Feet
 (2,4) Height to Top of Sign 11 Feet Clearance to Grade 8 Feet

Existing Signage/Type:	
<input checked="" type="checkbox"/> F.W. Non-Illuminated	16.5 Sq. Ft.
<input checked="" type="checkbox"/> F.W. Non-Illuminated	14 Sq. Ft.
<input checked="" type="checkbox"/> F.W. Non-Illuminated	8 Sq. Ft.
Total Existing:	38.5 Sq. Ft.

● FOR OFFICE USE ONLY ●		
Signage Allowed on Parcel: <u>29 ROAD</u>		
Building	<u>498</u>	Sq. Ft.
Free-Standing	<u>615</u>	Sq. Ft.
Total Allowed:	<u>615</u>	Sq. Ft.

COMMENTS: _____

NOTE: No sign may exceed 300 square feet. A separate sign permit is required for each sign. Attach a sketch of proposed and existing signage including types, dimensions, lettering, abutting streets, alleys, easements, property lines, and locations.

Roy McManis 7/25/97 [Signature] 7-31-97
 Applicant's Signature Date Community Development Approval Date
 (White: Community Development) (Canary: Applicant) (Pink: Code Enforcement)

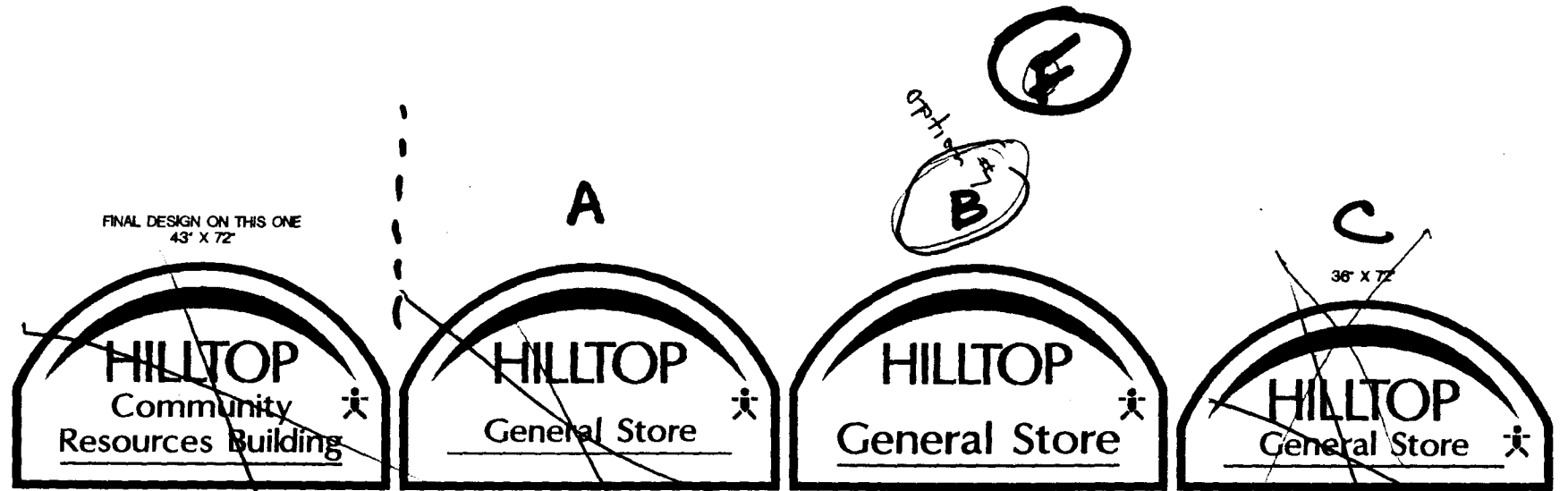

2897
NO. AVE

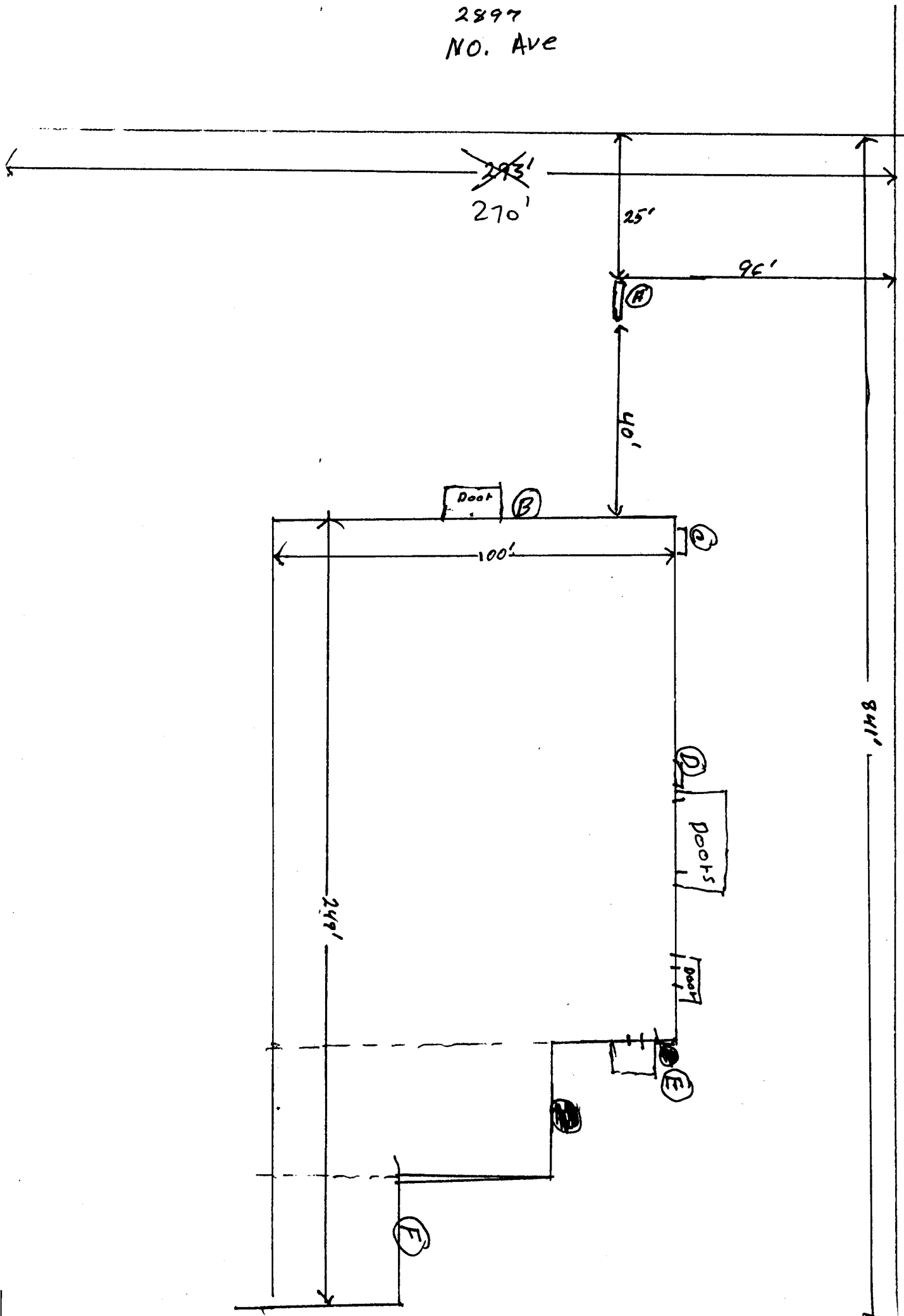

2d id