



SIGN CLEARANCE

Community Development Department
250 North 5th Street
Grand Junction, CO 81501
(970) 244-1430

Clearance No. 67974
Date Submitted 12-3-98
FEE \$ _____
Tax Schedule 2945-091-17-004
Zone _____

BUSINESS NAME Laser, Ink
STREET ADDRESS 2479 Commerce Blvd
PROPERTY OWNER Doug Beyer
OWNER ADDRESS 783 North Sedona Ct

CONTRACTOR Canvas Products Co
LICENSE NO. 2980181
ADDRESS 580 25 Road
TELEPHONE NO. 242-1453

- 1. FLUSH WALL 2 Square Feet per Linear Foot of Building Facade
- 2. ROOF 2 Square Feet per Linear Foot of Building Facade
- 3. FREE-STANDING 2 Traffic Lanes - 0.75 Square Feet x Street Frontage
4 or more Traffic Lanes - 1.5 Square Feet x Street Frontage
- 4. PROJECTING 0.5 Square Feet per each Linear Foot of Building Facade
- 5. OFF-PREMISE See #3 Spacing Requirements; Not > 300 Square Feet or < 15 Square Feet

Externally Illuminated Internally Illuminated Non-Illuminated

- (1 - 5) Area of Proposed Sign 12 Square Feet
- (1,2,4) Building Facade 40 Linear Feet
- (1 - 4) Street Frontage 100 Linear Feet
- (2,4,5) Height to Top of Sign _____ Feet Clearance to Grade _____ Feet
- (5) Distance from all Existing Off-Premise Signs within 600 Feet _____ Feet

Existing Signage/Type:	
<u>None</u>	Sq. Ft.
	Sq. Ft.
	Sq. Ft.
Total Existing:	<u>0</u> Sq. Ft.

● FOR OFFICE USE ONLY ●		
Signage Allowed on Parcel:		
Building	<u>80</u>	Sq. Ft.
Free-Standing	<u>75</u>	Sq. Ft.
Total Allowed:	<u>80</u>	Sq. Ft.

COMMENTS: transfer flush wall allowance from Commerce Blvd facade

NOTE: No sign may exceed 300 square feet. A separate sign clearance is required for each sign. Attach a sketch of proposed and existing signage including types, dimensions, lettering, abutting streets, alleys, easements, property lines, and locations. **A SEPARATE PERMIT FROM THE BUILDING DEPARTMENT IS REQUIRED.**

Don Dylis 12-3-98 Kathleen M. Porten 12/3/98
Applicant's Signature Date Community Development Approval Date

(White: Community Development) (Canary: Applicant) (Pink: Building Dept) (Goldenrod: Code Enforcement)

Purchase Order # _____

Date 11-6-98

Name Laser Ink

Phone _____

Address _____

Quote _____

Promised By _____

Instructions: No Balance

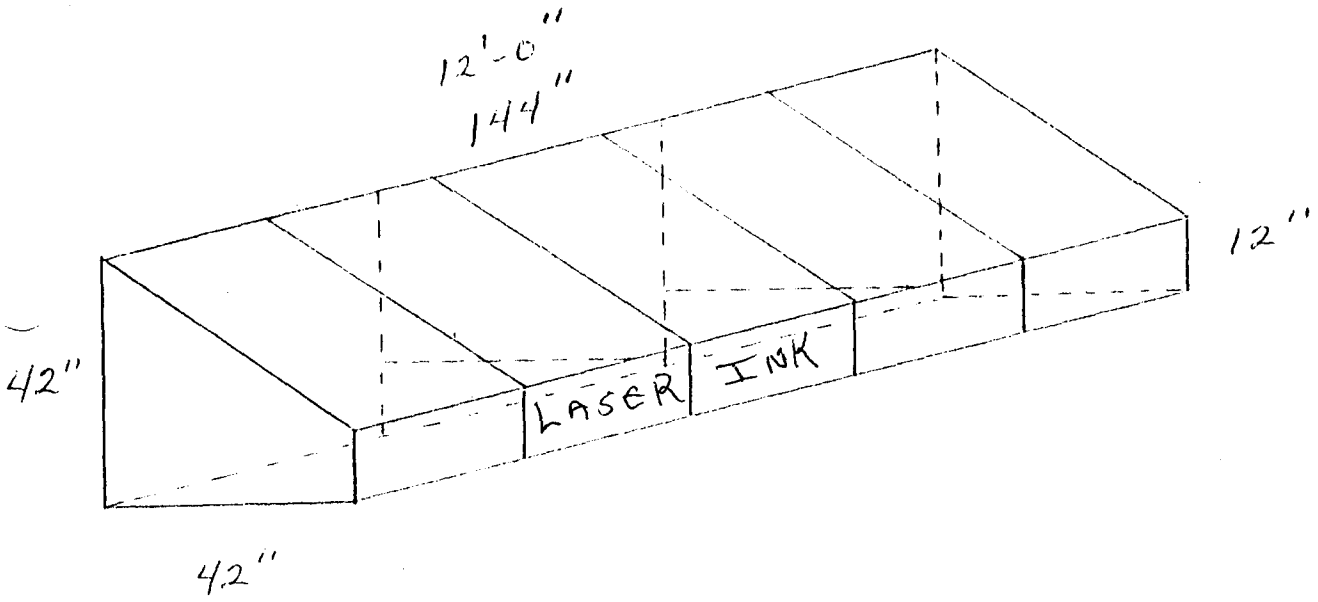

Operator _____

Time _____

Notified _____

Material _____

Tax _____

Total _____

GANUAS Products Co
580 25 Road
242-1453
Tom Dykstra

Site Plan

LASER, INK
2479 Commerce Blvd
248-4334
Doug Beyer

