



SIGN PERMIT

Community Development Department
 250 North 5th Street
 Grand Junction, CO 81501
 (970) 244-1430

Permit No. _____
 Date Submitted 9/22/00
 FEE \$ 25.00
 Tax Schedule 2945-091-03-376
 Zone C-1

BUSINESS NAME GIRL SCOUTS OF CITIPETA Council CONTRACTOR SIGNS FIRST
 STREET ADDRESS SEC 24 1/2 RD LICENSE NO. 2200323
 PROPERTY OWNER GIRL SCOUTS OF CITIPETA Council ADDRESS 950 NORTH AVE.
 OWNER ADDRESS 580 24 1/2 RD. TELEPHONE NO. 256-1877

- 1. FLUSH WALL 2 Square Feet per Linear Foot of Building Facade
- Face Change Only (2,3 & 4):**
- 2. ROOF 2 Square Feet per Linear Foot of Building Facade
- 3. FREE-STANDING 2 Traffic Lanes - 0.75 Square Feet x Street Frontage
4 or more Traffic Lanes - 1.5 Square Feet x Street Frontage
- 4. PROJECTING 0.5 Square Feet per each Linear Foot of Building Facade

Existing Externally or Internally Illuminated - No Change in Electrical Service Non-Illuminated

- (1 - 4) Area of Proposed Sign 24 Square Feet
- (1,2,4) Building Facade 41 Linear Feet
- (1 - 4) Street Frontage 155 Linear Feet
- (2,4) Height to Top of Sign 15' 4 1/2" Feet Clearance to Grade 8' 10" Feet

Existing Signage/Type:	
<u>FS</u>	<u>42</u> Sq. Ft.
	Sq. Ft.
	Sq. Ft.
Total Existing:	Sq. Ft.

● FOR OFFICE USE ONLY ●	
Signage Allowed on Parcel:	<u>24 1/2 RD</u>
Building	<u>82</u> Sq. Ft.
Free-Standing	<u>232.5</u> Sq. Ft.
Total Allowed:	<u>232.5</u> Sq. Ft.

COMMENTS: * ADD UNLIGHTED RETAPER BOARD FLUSH MOUNT TO EXISTING POLES.

NOTE: No sign may exceed 300 square feet. A separate sign permit is required for each sign. Attach a sketch of proposed and existing signage including types, dimensions, lettering, abutting streets, alleys, easements, property lines, and locations.

[Signature] 9/22/00 [Signature] 9/22/00
 Applicant's Signature Date Community Development Approval Date
 (White: Community Development) (Canary: Applicant) (Pink: Code Enforcement)

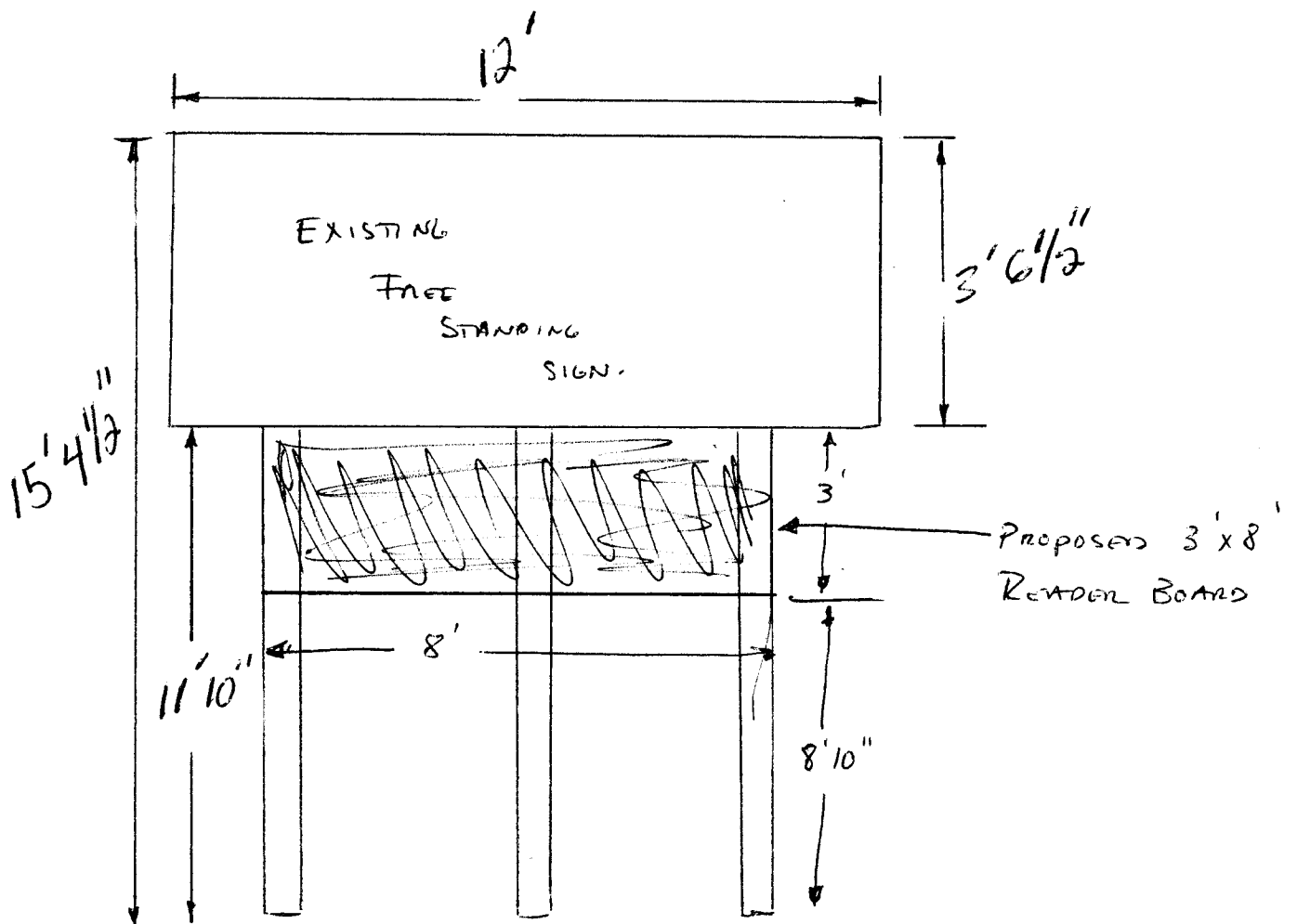

Address 580 29 1/2 RD.

