



SIGN PERMIT

Community Development Department
250 North 5th Street
Grand Junction, CO 81501
(970) 244-1430

Permit No. _____
Date Submitted 12-22-00
FEE \$ 25.00
Tax Schedule 2945-144-43-004
Zone C-1

BUSINESS NAME Discount Kids CONTRACTOR Bud's signs
STREET ADDRESS 719 Pitkin Suite 2 LICENSE NO. 2200100
PROPERTY OWNER Vicki Stacy Hilda Landeras ADDRESS 1055 Ute Ave.
OWNER ADDRESS 719 Pitkin Ave TELEPHONE NO. 245-7700

- 1. FLUSH WALL 2 Square Feet per Linear Foot of Building Facade
- X 2. ROOF 2 Square Feet per Linear Foot of Building Facade
- 3. FREE-STANDING 2 Traffic Lanes - 0.75 Square Feet x Street Frontage
4 or more Traffic Lanes - 1.5 Square Feet x Street Frontage
- 4. PROJECTING 0.5 Square Feet per each Linear Foot of Building Facade

Existing Externally or Internally Illuminated - No Change in Electrical Service Non-Illuminated

(1 - 4) Area of Proposed Sign 16 Square Feet
(1,2,4) Building Facade 80 Linear Feet
(1 - 4) Street Frontage 80 Linear Feet 140' for Lot
(2,3,4) Height to Top of Sign 12 Feet Clearance to Grade 10 Feet

Existing Signage/Type:	
	Sq. Ft.
	Sq. Ft.
	Sq. Ft.
Total Existing:	<u>0</u> Sq. Ft.

● FOR OFFICE USE ONLY ●		
Signage Allowed on Parcel: <u>Pitkin Ave</u>		
Building	<u>46</u>	Sq. Ft.
Free-Standing	<u>210</u>	Sq. Ft.
Total Allowed:	<u>210</u>	Sq. Ft.

COMMENTS: No existing signage on Building

NOTE: No sign may exceed 300 square feet. A separate sign permit is required for each sign. Attach a sketch of proposed and existing signage including types, dimensions, lettering, abutting streets, alleys, easements, property lines, and locations. Roof signs shall be manufactured such that no guy wires, braces or supports shall be visible.

Cire Bennett 12-22-00 Lori U. Bower 12-27-00
Applicant's Signature Date Community Development Approval Date

(White: Community Development) (Canary: Applicant) (Pink: Code Enforcement)

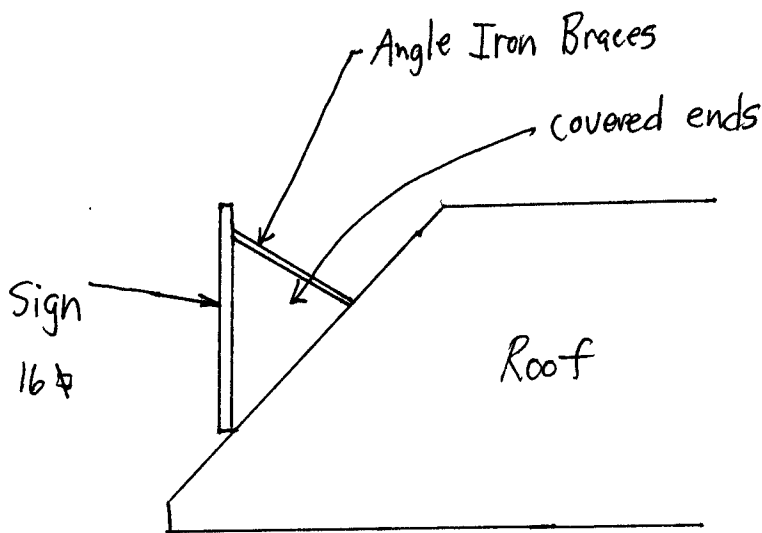
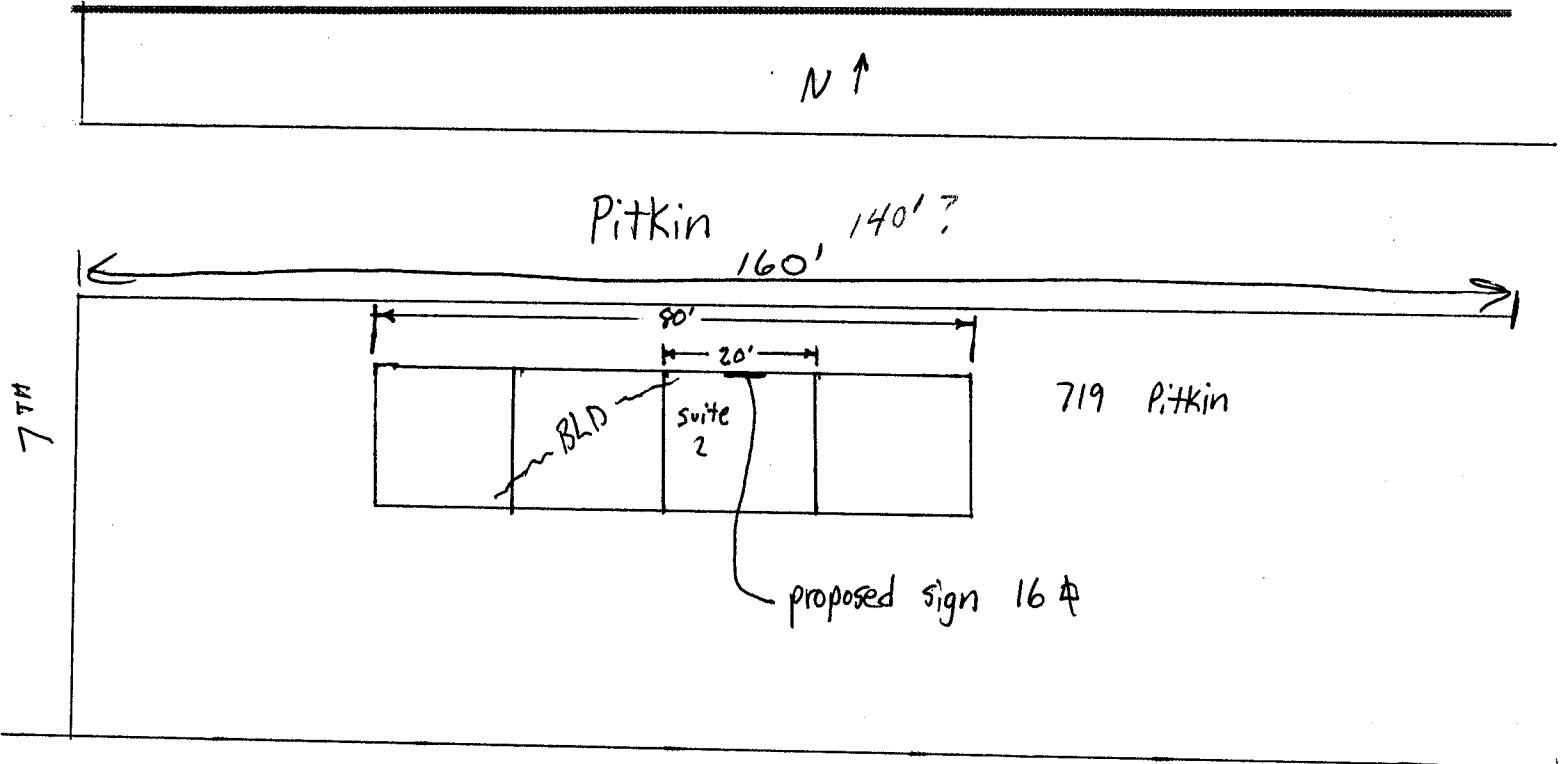

8'

DISCOUNT KIDS
- NEW & USED CLOTHING -
Accessories for Infant to Children

2'