



# CLEARANCE SIGN Permit

Community Development Department  
250 North 5<sup>th</sup> Street  
Grand Junction CO 81501  
Phone: (970) 244-1430 FAX (970) 256-4031

AC

80469

①

Permit No.	_____
Date Submitted	_____
Fee \$	<u>25<sup>00</sup></u>
Zone	<u>C-1/C-2</u>

TAX SCHEDULE <u>2943-181-15-001</u>	CONTRACTOR <u>Advertising Concepts, Inc.</u>
BUSINESS NAME <u>Wal-Mart Supercenter</u>	LICENSE NO. <u>2200571</u>
STREET ADDRESS <u>2881 North Avenue</u>	ADDRESS <u>3725 Canal Dr, Ft Collins, CO 80524</u>
PROPERTY OWNER <u>Wal-Mart Stores, Inc.</u>	TELEPHONE NO. <u>970-484-3637</u>
OWNER ADDRESS <u>2001 SE 10<sup>th</sup> St, Bentonville, AR</u>	CONTACT PERSON <u>Marie Locke</u>

<input type="checkbox"/> 1. FLUSH WALL	2 Square Feet per Linear Foot of Building Façade
<b>Face change only on items 2, 3 &amp; 4</b>	
<input type="checkbox"/> 2. ROOF	2 Square Feet per Linear Foot of Building Façade
<input checked="" type="checkbox"/> 3. FREE-STANDING	2 Traffic Lanes - 0.75 Square Feet x Street Frontage 4 or more Traffic Lanes - 1.5 Square Feet x Street Frontage
<input type="checkbox"/> 4. PROJECTING	0.5 Square Feet per each Linear Foot of Building Façade

Existing Externally or Internally Illuminated - No Change in Electrical Service       Non-Illuminated

(1 - 4) Area of Proposed Sign: 160.34 Square Feet  
 (1,2,4) Building Façade: ~~1975~~ Linear Feet 690  
 (1 - 4) Street Frontage: 825 Linear Feet  
 (2 - 4) Height to Top of Sign: 30' Feet      Clearance to Grade: 17'-9" Feet

**EXISTING SIGNAGE/TYPE:**

<u>All removed EXISTING SIGNAGE</u>	Sq. Ft.
_____	Sq. Ft.
_____	Sq. Ft.
Total Existing: <u>0</u>	Sq. Ft.

**● FOR OFFICE USE ONLY ●**

NOVOTH AVE  
Signage Allowed on Parcel:

Building	<u>1380</u>	Sq. Ft.
Free-Standing	<u>300</u>	Sq. Ft.
Total Allowed:	<u>1380</u>	Sq. Ft.

COMMENTS: One (1) sign on this application. REQUIRES A BUILDING PERMIT FROM MESA Co. BUILDING DEPT.

NOTE: No sign may exceed 300 square feet. A separate sign permit is required for each sign. Attach a sketch, to scale, of proposed and existing signage including types, dimensions and lettering. Attach a plot plan, to scale, showing: abutting streets, alleys, easements, driveways, encroachments, property lines, distances from existing buildings to proposed signs and required setbacks. Roof signs shall be manufactured such that no guy wires, braces or supports shall be visible.

I hereby attest that the information on this form and the attached sketches are true and accurate.

<u>Marie Locke</u>	<u>07-11-01</u>	<u>Bill Nuth</u>	<u>7-20-01</u>
Applicant's Signature	Date	Community Development Approval	Date

(White: Community Development)      (Canary: Applicant)      (Pink: Code Enforcement)

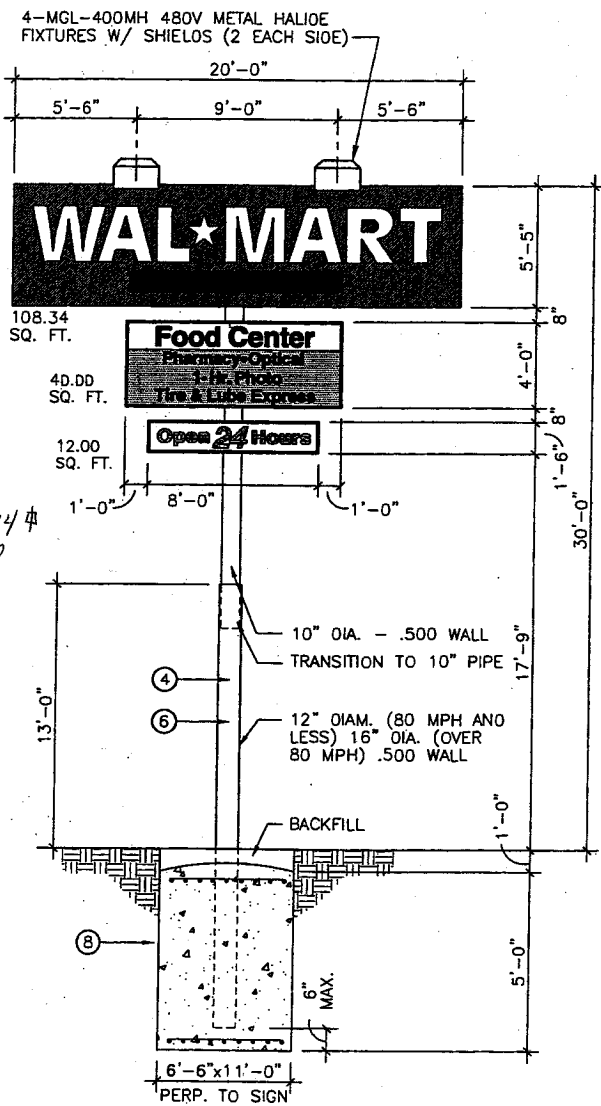

1 FRONT VIEW

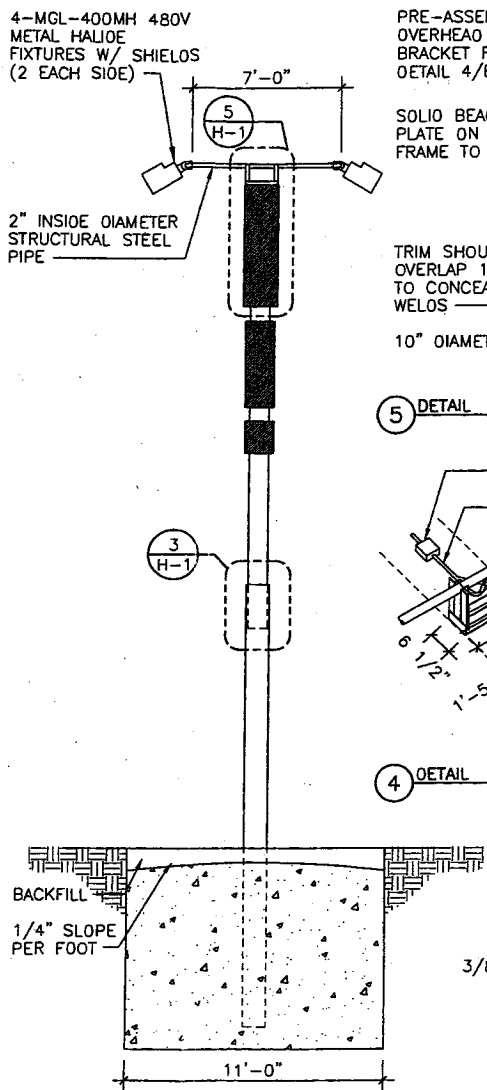

2 SIDE VIEW

3 DETAIL

**KEY NOTES:**

- SHALL BE WHITE PRE-PAINTED ALUMINUM OR WHITE VINYL LETTERS, ANTIQUE OLIVE BOLD LETTER STYLE.
- SHALL BE BLUE (MATCH SHERWIN WILLIAMS #1504) PRE-PAINTED ALUMINUM.
- SHALL BE YELLOW PRE-PAINTED ALUMINUM OR YELLOW VINYL LETTERS, HELVETICA LETTER STYLE WITH 15' SLANT, FORCED @ 7%, 2 EACH.
- SIGN SUPPORT SHOULD BE PAINTED SHERWIN WILLIAMS #1504.
- SHALL BE PAINTED RED (MATCH SHERWIN WILLIAMS #1602 THEATER RED)
- COLUMN STEEL: ASTM A501 (FY=36KSI) OR ASTM A53 TYPE E OR S, GRADE B (FY=35KSI).
- SHALL BE WHITE VINYL LETTERS, HELVETICA MEDIUM LETTER STYLE.
- CONCRETE STRENGTH F'C= 3000PSI @ 28 DAYS.

**CONTRACTORS' DUTIES:**

- CONTRACTOR MUST REMOVE ALL EXCESS DIRT.
- BACKFILL OVER CONCRETE FOOTINGS.
- CONTRACTOR SHALL PAINT POLES AND ANY ATTACHED HARDWARE, CONDUIT, ELECTRICAL BOXES, ETC. MATCH SHERWIN WILLIAMS #1504 BLUE.
- NOTIFY WAL-MART SIGN SHOP BEFORE EXCAVATING ANY PLANNED LANDSCAPED AREA.
- CLEAN UP ALL DEBRIS.
- CLEAN FACE AND RETURN OF ALL SIGNS AFTER COMPLETED INSTALLATION.

**LIGHTING NOTES:**

- MOUNT LIGHT FIXTURES AT 60" PER BRACKET MARKS.
- SUPPORT PIPE: 2" INSIDE DIAMETER, 7'-0" LONG.
- SUPPORT BRACKET TO BE 2"x2"x1/8" ANGLES CENTERED ON PIPE. RE: #2
- DRILL 11/32" DIA MOUNTING HOLES 1" FROM EACH END, CENTERED ON ANGLE.
- ROUTE POWER UP THROUGH POLE, INTO 2" PIPE AND TO FIXTURES AT EACH END.
- PAINT FIXTURE ASSEMBLY, INCLUDING CONDUIT, BLUE.
- HARDWARE FOUND IN J-BOX:
 

(8) SELF-TAPPING BOLTS	(6) 3/4" DRILL SCREWS
(8) SS FLAT WASHERS	(2) TWO HOLE STRAPS
(3) BLUE WIRE NUTS	(1) 3/4" CHASE NIPPLE

**ENGINEERING NOTE:**  
DESIGN IS BASED ON REQUIREMENTS OF ASCE-7 AND UBC CRITERIA USING A53 STEEL PIPE AND CONCRETE WITH A 28 DAY COMPRESSIVE STRENGTH OF 3000 PSI.

5'-5" X 20'-0" - 4'-0" X 10'-0" - 1'-6" X 8'-0" SUPERCENTER PYLON SIGNING	
<b>WAL-MART</b>	
REVISION DATE: 09-15-00	
<b>H-1</b>	

NOTE: DRAWINGS ON SHEET NOT TO SCALE.

166.34 # Total

N.T.S. TOTAL 160.34 SQ. FT.

N.T.S.

