



# SIGN PERMIT

2

Community Development Department  
250 North 5th Street  
Grand Junction, CO 81501  
(970) 244-1430

Permit No. \_\_\_\_\_  
Date Submitted \_\_\_\_\_  
FEE \$ 25.00  
Tax Schedule 29456-103-30-001  
Zone C-2

BUSINESS NAME Small Wonders  
STREET ADDRESS 545 25 1/2 Road  
PROPERTY OWNER Mike & Stephanie McGuire  
OWNER ADDRESS 532 34 Road Clifton

CONTRACTOR Buds Signs  
LICENSE NO. 2030106  
ADDRESS 1055 Ute  
TELEPHONE NO. 245-7700

- 1. FLUSH WALL 2 Square Feet per Linear Foot of Building Facade
- Face Change Only (2,3 & 4):**
- 2. ROOF 2 Square Feet per Linear Foot of Building Facade
- 3. FREE-STANDING 2 Traffic Lanes - 0.75 Square Feet x Street Frontage  
4 or more Traffic Lanes - 1.5 Square Feet x Street Frontage
- 4. PROJECTING 0.5 Square Feet per each Linear Foot of Building Facade

Existing Externally or Internally Illuminated - No Change in Electrical Service  Non-Illuminated

(1 - 4) Area of Proposed Sign 62.16 Square Feet  
(1,2,4) Building Facade 50 Linear Feet  
(1 - 4) Street Frontage 265 Linear Feet  
(2,3,4) Height to Top of Sign 12' Feet Clearance to Grade 10'-6" Feet

Existing Signage/Type:	
<u>Free-standing</u>	<u>12</u> Sq. Ft.
	Sq. Ft.
	Sq. Ft.
Total Existing:	<u>12</u> Sq. Ft.

● FOR OFFICE USE ONLY ●	
Signage Allowed on Parcel:	<u>25 1/2 Rd</u>
Building	<u>100</u> Sq. Ft.
Free-Standing	<u>198</u> Sq. Ft.
Total Allowed:	<u>198</u> Sq. Ft.

COMMENTS: \_\_\_\_\_

**NOTE:** No sign may exceed 300 square feet. A separate sign permit is required for each sign. Attach a sketch of proposed and existing signage including types, dimensions, lettering, abutting streets, alleys, easements, property lines, and locations. Roof signs shall be manufactured such that no guy wires, braces or supports shall be visible.

Aric Bennett Applicant's Signature      \_\_\_\_\_ Date      [Signature] Community Development Approval      11/3/03 Date

(White: Community Development)      (Canary: Applicant)      (Pink: Code Enforcement)

# BWA'S SIGNS and Neon

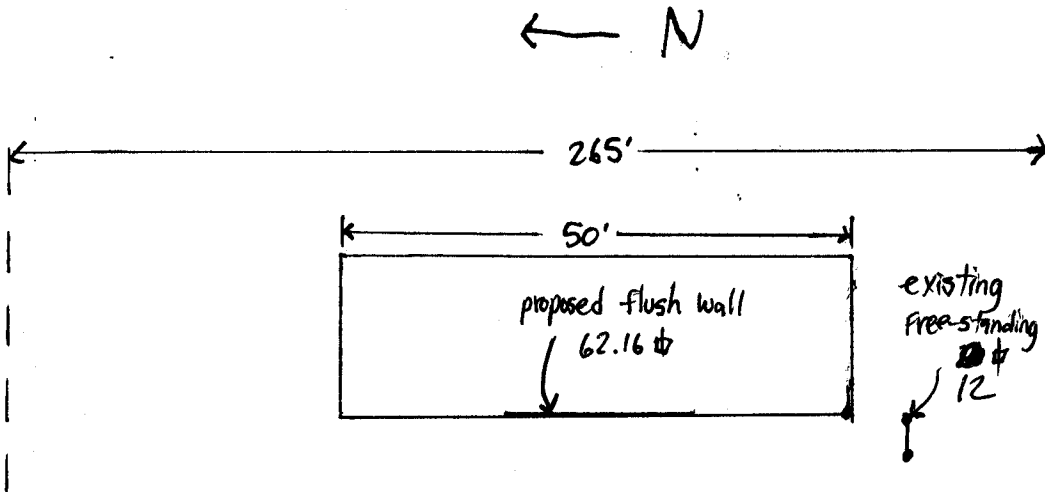

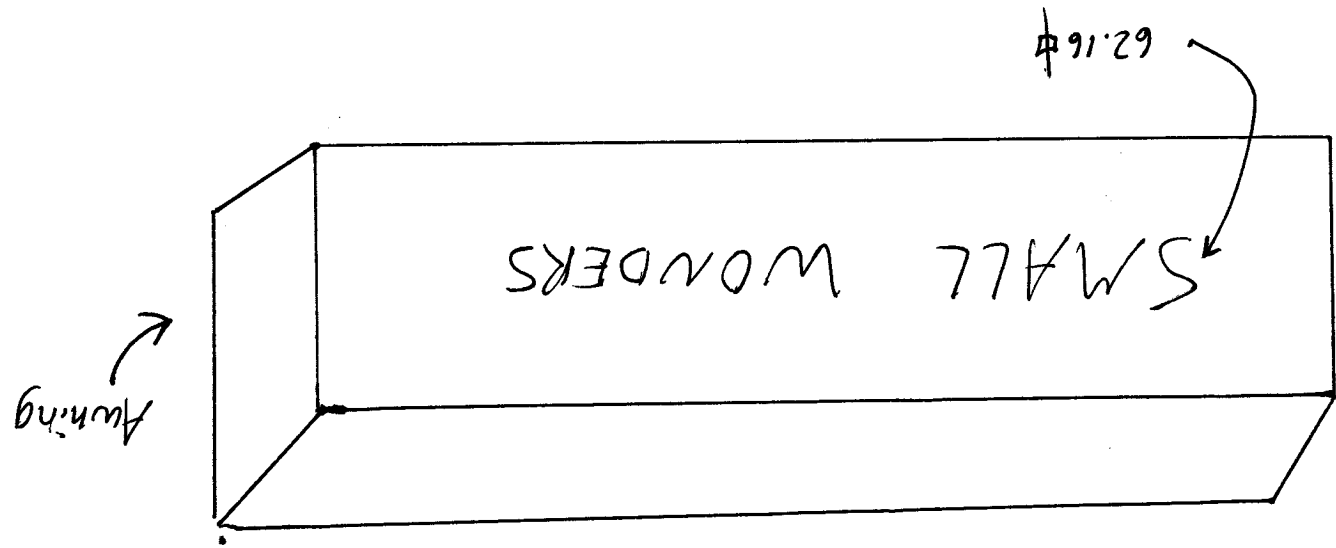



**CITY OF GRAND JUNCTION**  
Community Development Department  
Code Enforcement Division  
2549 River Road - Grand Junction CO 81505  
(970) 244-1593 - FAX (970) 256-4114

**VOLUNTARY COMPLIANCE REQUEST**

October 28, 2003

Small Wonders  
545 25 1/2 Rd.  
Grand Junction CO 81505

Re: signs

The above location has been identified as having the following Zoning and Development Code violation:

ED

4.2.F.1.a. Permits are required for all new signs. The alteration of sign faces by painting or overlay is considered construction of a new sign and requires a permit. No new permit is found for this location.

4.2.B.d. Signs that contain or consist of portable signs or tent signs.

You may correct the violations by obtaining a permit for the face change on the existing signs by the date below and removing the portable sign upon receipt of this letter. Voluntary correction of the violation will eliminate the need for additional enforcement action that may include a Notice of Violation and Summons, penalties from municipal court, and/or correction of violation(s) at owner's expense. INSPECTION OF THIS PROPERTY IS SCHEDULED ON OR AFTER 11/10/03.

Your City government is working to maintain a safe, healthy and pleasant community. Your cooperation in eliminating the violation(s) by the above inspection date is appreciated. Please call this office if you have any questions.

Respectfully

*Nina McNally*  
Nina McNally  
Code Enforcement Officer  
(970) 256-4103  
ninam@ci.grandjct.co.us

*encl.*

*10/28/03*

*Community Development  
ON R  
Events Permit*