



SIGN CLEARANCE

Community Development Department
250 North 5th Street
Grand Junction CO 81501
(970) 244-1430

Clearance No. _____
 Date Submitted 11/22/04
 Fee \$ 25.00
 Zone C-2

TAX SCHEDULE 2945-103-37-007 CONTRACTOR Platinum Sign Co.
 BUSINESS NAME Chick-Fit-A LICENSE NO. 2040850
 STREET ADDRESS 522 Bogart Ln ADDRESS 2916 I-70 B
 PROPERTY OWNER _____ TELEPHONE NO. 248-9677
 OWNER ADDRESS _____ CONTACT PERSON Mike Blackwelder Jr

- 1. FLUSH WALL 1.75 Square Feet per Linear Foot of Building Facade
- 2. ROOF 2 Square Feet per Linear Foot of Building Facade
- 3. FREE-STANDING Monument Sign 2 Traffic Lanes - 0.75 Square Feet x Street Frontage
4 or more Traffic Lanes - 1.5 Square Feet x Street Frontage
- 4. PROJECTING 0.5 Square Feet per each Linear Foot of Building Facade
- 5. OFF-PREMISE See #3 Spacing Requirements; Not > 300 Square Feet or < 15 Square Feet

Externally Illuminated Internally Illuminated Non-Illuminated

(1 - 5) Area of Proposed Sign: 35.15 Square Feet
 (1,2,4) Building Façade: 91'3" Linear Feet East
 (1 - 4) Street Frontage: 225' Linear Feet Rimrock Ave
 (2 - 5) Height to Top of Sign: 6 Feet Clearance to Grade: 10" Feet
 (5) Distance from all Existing Off-Premise Signs within 600 Feet: _____ Feet

EXISTING SIGNAGE/TYPE:	
<u>Flush wall 4) CS, A4</u>	<u>48.45</u> Sq. Ft.
_____	_____ Sq. Ft.
_____	_____ Sq. Ft.
Total Existing:	_____ Sq. Ft.

● FOR OFFICE USE ONLY ●	
Signage Allowed on Parcel: <u>Rimrock Ave</u>	
Building	<u>159.7</u> Sq. Ft.
<u>Per file</u> Free-Standing	<u>60</u> Sq. Ft.
Total Allowed:	<u>159.7</u> Sq. Ft.

COMMENTS: Per Rimrock File - Monument Sign

NOTE: No sign may exceed 300 square feet. A separate sign clearance is required for each sign. Attach a sketch, to scale, of proposed and existing signage including types, dimensions and lettering. Attach a plot plan, to scale, showing: abutting streets, alleys, easements, driveways, encroachments, property lines, distances from existing buildings to proposed signs and required setbacks. A SEPARATE PERMIT FROM THE BUILDING DEPARTMENT IS ALSO REQUIRED.

I hereby attest that the information on this form and the attached sketches are true and accurate.

Mike Blackwelder Jr 11-29-04 Bobbie Paulson 11/23/04
 Applicant's Signature Date Community Development Approval Date

(White: Community Development) (Canary: Applicant) (Pink: Building Dept) (Goldenrod: Code Enforcement)



SIGN CLEARANCE

Community Development Department
250 North 5th Street
Grand Junction CO 81501
(970) 244-1430

2A-4

(B)

Clearance No.	_____
Date Submitted	<u>11-22-04</u>
Fee \$	<u>15.00</u>
Zone	<u>C-2</u>

TAX SCHEDULE <u>2945-103-37-007</u>	CONTRACTOR <u>Platinum Sign Co</u>
BUSINESS NAME <u>Chick-Fly-A</u>	LICENSE NO. <u>2040850</u>
STREET ADDRESS <u>522 Bogart Ln</u>	ADDRESS <u>2916 E. 70 B</u>
PROPERTY OWNER _____	TELEPHONE NO. <u>248-9677</u>
OWNER ADDRESS _____	CONTACT PERSON <u>Mike Blackwelder Jr.</u>

<input checked="" type="checkbox"/> 1. FLUSH WALL	<u>1.75</u> Square Feet per Linear Foot of Building Facade
<input type="checkbox"/> 2. ROOF	2 Square Feet per Linear Foot of Building Facade
<input type="checkbox"/> 3. FREE-STANDING	2 Traffic Lanes - 0.75 Square Feet x Street Frontage 4 or more Traffic Lanes - 1.5 Square Feet x Street Frontage
<input type="checkbox"/> 4. PROJECTING	0.5 Square Feet per each Linear Foot of Building Facade
<input type="checkbox"/> 5. OFF-PREMISE	See #3 Spacing Requirements; Not > 300 Square Feet or < 15 Square Feet

Externally Illuminated Internally Illuminated Non-Illuminated

(1 - 5) Area of Proposed Sign: 39.7 Square Feet
 (1,2,4) Building Façade: 91'3" Linear Feet East Elevation
 (1 - 4) Street Frontage: 225 Linear Feet
 (2 - 5) Height to Top of Sign: _____ Feet Clearance to Grade: _____ Feet
 (5) Distance from all Existing Off-Premise Signs within 600 Feet: _____ Feet

EXISTING SIGNAGE/TYPE:	
<u>40A4</u>	<u>39.7</u> Sq. Ft.
_____	_____ Sq. Ft.
_____	_____ Sq. Ft.
_____	_____ Sq. Ft.
Total Existing:	<u>39.7</u> Sq. Ft.

● FOR OFFICE USE ONLY ●	
Signage Allowed on Parcel: <u>Kimrock Ave</u>	
<u>60</u> # Building	<u>159.7</u> Sq. Ft.
Free-Standing	<u>202.5</u> Sq. Ft.
Total Allowed:	<u>159.7</u> Sq. Ft.

COMMENTS: Per Kimrock File

NOTE: No sign may exceed 300 square feet. A separate sign clearance is required for each sign. Attach a sketch, to scale, of proposed and existing signage including types, dimensions and lettering. Attach a plot plan, to scale, showing: abutting streets, alleys, easements, driveways, encroachments, property lines, distances from existing buildings to proposed signs and required setbacks. A SEPARATE PERMIT FROM THE BUILDING DEPARTMENT IS ALSO REQUIRED.

I hereby attest that the information on this form and the attached sketches are true and accurate.

[Signature] 11-29-04 Bobbi Paulson 11/23/04
 Applicant's Signature Date Community Development Approval Date

(White: Community Development) (Canary: Applicant) (Pink: Building Dept) (Goldenrod: Code Enforcement)



SIGN CLEARANCE

Community Development Department
250 North 5th Street
Grand Junction CO 81501
(970) 244-1430

Clearance No. _____
Date Submitted 11/22/04
Fee \$ 5.00
Zone C-2

4) C5

TAX SCHEDULE 2945103-37-007
BUSINESS NAME Chick-Fit-A
STREET ADDRESS 522 Bogart Ln
PROPERTY OWNER _____
OWNER ADDRESS _____

CONTRACTOR Platinum Sign Co
LICENSE NO. 2040850
ADDRESS 2916 I-70 B
TELEPHONE NO. 248-9677
CONTACT PERSON Mike Blackwelder Jr.

- 1. FLUSH WALL 1.75 Square Feet per Linear Foot of Building Facade
- 2. ROOF 2 Square Feet per Linear Foot of Building Facade
- 3. FREE-STANDING 2 Traffic Lanes - 0.75 Square Feet x Street Frontage
4 or more Traffic Lanes - 1.5 Square Feet x Street Frontage
- 4. PROJECTING 0.5 Square Feet per each Linear Foot of Building Facade
- 5. OFF-PREMISE See #3 Spacing Requirements; Not > 300 Square Feet or < 15 Square Feet

Externally Illuminated Internally Illuminated Non-Illuminated

(1 - 5) Area of Proposed Sign: 8.75 Square Feet
(1,2,4) Building Façade: 91'3" Linear Feet East-Side Elevation
(1 - 4) Street Frontage: 225' Linear Feet Rimrock Ave
(2 - 5) Height to Top of Sign: _____ Feet Clearance to Grade: _____ Feet
(5) Distance from all Existing Off-Premise Signs within 600 Feet: _____ Feet

EXISTING SIGNAGE/TYPE:

<u>4) A4</u>	<u>39.7</u>	Sq. Ft.
_____	_____	Sq. Ft.
_____	_____	Sq. Ft.
_____	_____	Sq. Ft.
Total Existing:	<u>39.7</u>	Sq. Ft.

● FOR OFFICE USE ONLY ●

Signage Allowed on Parcel: Rimrock Ave

Building 337.5 Sq. Ft.

Free-Standing per file 60. Sq. Ft.

Total Allowed: 337.5 Sq. Ft.

COMMENTS: per file

NOTE: No sign may exceed 300 square feet. A separate sign clearance is required for each sign. Attach a sketch, to scale, of proposed and existing signage including types, dimensions and lettering. Attach a plot plan, to scale, showing: abutting streets, alleys, easements, driveways, encroachments, property lines, distances from existing buildings to proposed signs and required setbacks. A SEPARATE PERMIT FROM THE BUILDING DEPARTMENT IS ALSO REQUIRED.

I hereby attest that the information on this form and the attached sketches are true and accurate.

[Signature] 11-29-04 Bobbie Paulson 11/23/04
Applicant's Signature Date Community Development Approval Date

(White: Community Development) (Canary: Applicant) (Pink: Building Dept) (Goldenrod: Code Enforcement)



SIGN CLEARANCE

Community Development Department
250 North 5th Street
Grand Junction CO 81501
(970) 244-1430

Clearance No. _____
 Date Submitted 11-22-04
 Fee \$ 5.00
 Zone C-2

5)A4

TAX SCHEDULE 2945-103-37-007 CONTRACTOR Platinum Sign Co
 BUSINESS NAME Chuck-Fil-A LICENSE NO. 2040850
 STREET ADDRESS 522 Bogart Ln. ADDRESS 2916 I-70 B
 PROPERTY OWNER _____ TELEPHONE NO. 248-9677
 OWNER ADDRESS _____ CONTACT PERSON Mike Blackwelder Jr.

1. FLUSH WALL 1.75 Square Feet per Linear Foot of Building Facade
 2. ROOF 2 Square Feet per Linear Foot of Building Facade
 3. FREE-STANDING 2 Traffic Lanes - 0.75 Square Feet x Street Frontage
 4 or more Traffic Lanes - 1.5 Square Feet x Street Frontage
 4. PROJECTING 0.5 Square Feet per each Linear Foot of Building Facade
 5. OFF-PREMISE See #3 Spacing Requirements; Not > 300 Square Feet or < 15 Square Feet

Externally Illuminated Internally Illuminated Non-Illuminated

(1 - 5) Area of Proposed Sign: 39.7 Square Feet
 (1,2,4) Building Façade: 91'3" Linear Feet West Side Elevation
 (1 - 4) Street Frontage: 384 Linear Feet
 (2 - 5) Height to Top of Sign: _____ Feet Clearance to Grade: _____ Feet
 (5) Distance from all Existing Off-Premise Signs within 600 Feet: _____ Feet

EXISTING SIGNAGE/TYPE:
None _____ Sq. Ft.
 _____ Sq. Ft.
 _____ Sq. Ft.
 Total Existing: _____ Sq. Ft.

● FOR OFFICE USE ONLY ●
 Signage Allowed on Parcel: Bogart Ln
 Building 159.7 Sq. Ft.
 Free-Standing 607 512 Sq. Ft.
 Total Allowed: 159.7 Sq. Ft.

COMMENTS: Freestanding sign can only be 60" monument sign.

NOTE: No sign may exceed 300 square feet. A separate sign clearance is required for each sign. Attach a sketch, to scale, of proposed and existing signage including types, dimensions and lettering. Attach a plot plan, to scale, showing: abutting streets, alleys, easements, driveways, encroachments, property lines, distances from existing buildings to proposed signs and required setbacks. A SEPARATE PERMIT FROM THE BUILDING DEPARTMENT IS ALSO REQUIRED.

I hereby attest that the information on this form and the attached sketches are true and accurate.

[Signature] 11-29-04 Bobbie Paulson 11/23/04
 Applicant's Signature Date Community Development Approval Date

(White: Community Development) (Canary: Applicant) (Pink: Building Dept) (Goldenrod: Code Enforcement)

E



SIGN CLEARANCE

Community Development Department
250 North 5th Street
Grand Junction CO 81501
(970) 244-1430

Clearance No.	_____
Date Submitted	<u>11/22/04</u>
Fee \$	<u>500</u>
Zone	<u>C-2</u>

3)A4

TAX SCHEDULE	<u>2945-103-37-007</u>	CONTRACTOR	<u>Platinum Sign Co</u>
BUSINESS NAME	<u>Chick-Fil-A</u>	LICENSE NO.	<u>2040850</u>
STREET ADDRESS	<u>522 Bogart Ln</u>	ADDRESS	<u>2916 I-70 B</u>
PROPERTY OWNER	_____	TELEPHONE NO.	<u>248-9677</u>
OWNER ADDRESS	_____	CONTACT PERSON	<u>Mike Blackwelder Jr</u>

<input checked="" type="checkbox"/> 1. FLUSH WALL	1.75 ² Square Feet per Linear Foot of Building Facade
<input type="checkbox"/> 2. ROOF	2 Square Feet per Linear Foot of Building Facade
<input type="checkbox"/> 3. FREE-STANDING	2 Traffic Lanes - 0.75 Square Feet x Street Frontage 4 or more Traffic Lanes - 1.5 Square Feet x Street Frontage
<input type="checkbox"/> 4. PROJECTING	0.5 Square Feet per each Linear Foot of Building Facade
<input type="checkbox"/> 5. OFF-PREMISE	See #3 Spacing Requirements; Not > 300 Square Feet or < 15 Square Feet

Externally Illuminated Internally Illuminated Non-Illuminated

(1 - 5) Area of Proposed Sign: 39.7 Square Feet
 (1,2,4) Building Façade: 47'5" Linear Feet
 (1 - 4) Street Frontage: 270 Linear Feet Front Elevation (North)
 (2 - 5) Height to Top of Sign: _____ Feet Clearance to Grade: _____ Feet
 (5) Distance from all Existing Off-Premise Signs within 600 Feet: _____ Feet

EXISTING SIGNAGE/TYPE:

_____	_____	Sq. Ft.
_____	_____	Sq. Ft.
_____	_____	Sq. Ft.
Total Existing:	_____	Sq. Ft.

● FOR OFFICE USE ONLY ●

Signage Allowed on Parcel: Frontage Rd

Building	<u>82.25</u>	Sq. Ft.
Free-Standing	<u>202.5</u>	Sq. Ft.
Total Allowed:	<u>82.25</u>	Sq. Ft.

COMMENTS: Per Rimrock File

NOTE: No sign may exceed 300 square feet. A separate sign clearance is required for each sign. Attach a sketch, to scale, of proposed and existing signage including types, dimensions and lettering. Attach a plot plan, to scale, showing: abutting streets, alleys, easements, driveways, encroachments, property lines, distances from existing buildings to proposed signs and required setbacks. A SEPARATE PERMIT FROM THE BUILDING DEPARTMENT IS ALSO REQUIRED.

I hereby attest that the information on this form and the attached sketches are true and accurate.

[Signature] 11-29-04 [Signature] 11/23/04
 Applicant's Signature Date Community Development Approval Date

(White: Community Development) (Canary: Applicant) (Pink: Building Dept) (Goldenrod: Code Enforcement)



SIGN CLEARANCE

Community Development Department
250 North 5th Street
Grand Junction CO 81501
(970) 244-1430

4) A4

(6)

Clearance No.	_____
Date Submitted	11/22/04
Fee \$	5.00
Zone	C-2

TAX SCHEDULE	2945-103-37-007	CONTRACTOR	Platinum Sign Co
BUSINESS NAME	Chick-Fil-A	LICENSE NO.	2040850
STREET ADDRESS	522 Bogart Ln	ADDRESS	2916 I-70 B
PROPERTY OWNER	_____	TELEPHONE NO.	248-9677
OWNER ADDRESS	_____	CONTACT PERSON	Mike Blackwelder Jr

<input checked="" type="checkbox"/> 1. FLUSH WALL	1.752	Square Feet per Linear Foot of Building Facade
<input type="checkbox"/> 2. ROOF		2 Square Feet per Linear Foot of Building Facade
<input type="checkbox"/> 3. FREE-STANDING		2 Traffic Lanes - 0.75 Square Feet x Street Frontage
		4 or more Traffic Lanes - 1.5 Square Feet x Street Frontage
<input type="checkbox"/> 4. PROJECTING		0.5 Square Feet per each Linear Foot of Building Facade
<input type="checkbox"/> 5. OFF-PREMISE		See #3 Spacing Requirements; Not > 300 Square Feet or < 15 Square Feet
<input type="checkbox"/> Externally Illuminated <input type="checkbox"/> Internally Illuminated <input type="checkbox"/> Non-Illuminated		

(1 - 5) Area of Proposed Sign: 39.7 Square Feet
 (1,2,4) Building Façade: 113 Linear Feet South Side (Rear Elevation)
 (1 - 4) Street Frontage: 210 Linear Feet
 (2 - 5) Height to Top of Sign: _____ Feet Clearance to Grade: _____ Feet
 (5) Distance from all Existing Off-Premise Signs within 600 Feet: _____ Feet

EXISTING SIGNAGE/TYPE:	
_____	Sq. Ft.
_____	Sq. Ft.
_____	Sq. Ft.
_____	Sq. Ft.
Total Existing: _____	Sq. Ft.

● FOR OFFICE USE ONLY ●	
Signage Allowed on Parcel:	<u>Bogart Ln</u>
Building	<u>197.75</u> Sq. Ft.
Free-Standing	<u>0</u> Sq. Ft.
Total Allowed:	<u>197.75</u> Sq. Ft.

COMMENTS: Per Rimrock File

NOTE: No sign may exceed 300 square feet. A separate sign clearance is required for each sign. Attach a sketch, to scale, of proposed and existing signage including types, dimensions and lettering. Attach a plot plan, to scale, showing: abutting streets, alleys, easements, driveways, encroachments, property lines, distances from existing buildings to proposed signs and required setbacks. A SEPARATE PERMIT FROM THE BUILDING DEPARTMENT IS ALSO REQUIRED.

I hereby attest that the information on this form and the attached sketches are true and accurate.

[Signature] 11-29-04 Bobbi Paulson 11/23/04
 Applicant's Signature Date Community Development Approval Date

(White: Community Development) (Canary: Applicant) (Pink: Building Dept) (Goldenrod: Code Enforcement)

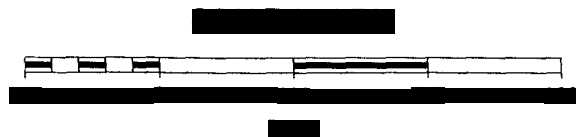

Chick - Fil - A
522 Bogart Lane





Grand Junction, Colorado

LEGEND

- R) Pedestrian crosswalk sign
- S) Two (2) Directional Signs "One Way"

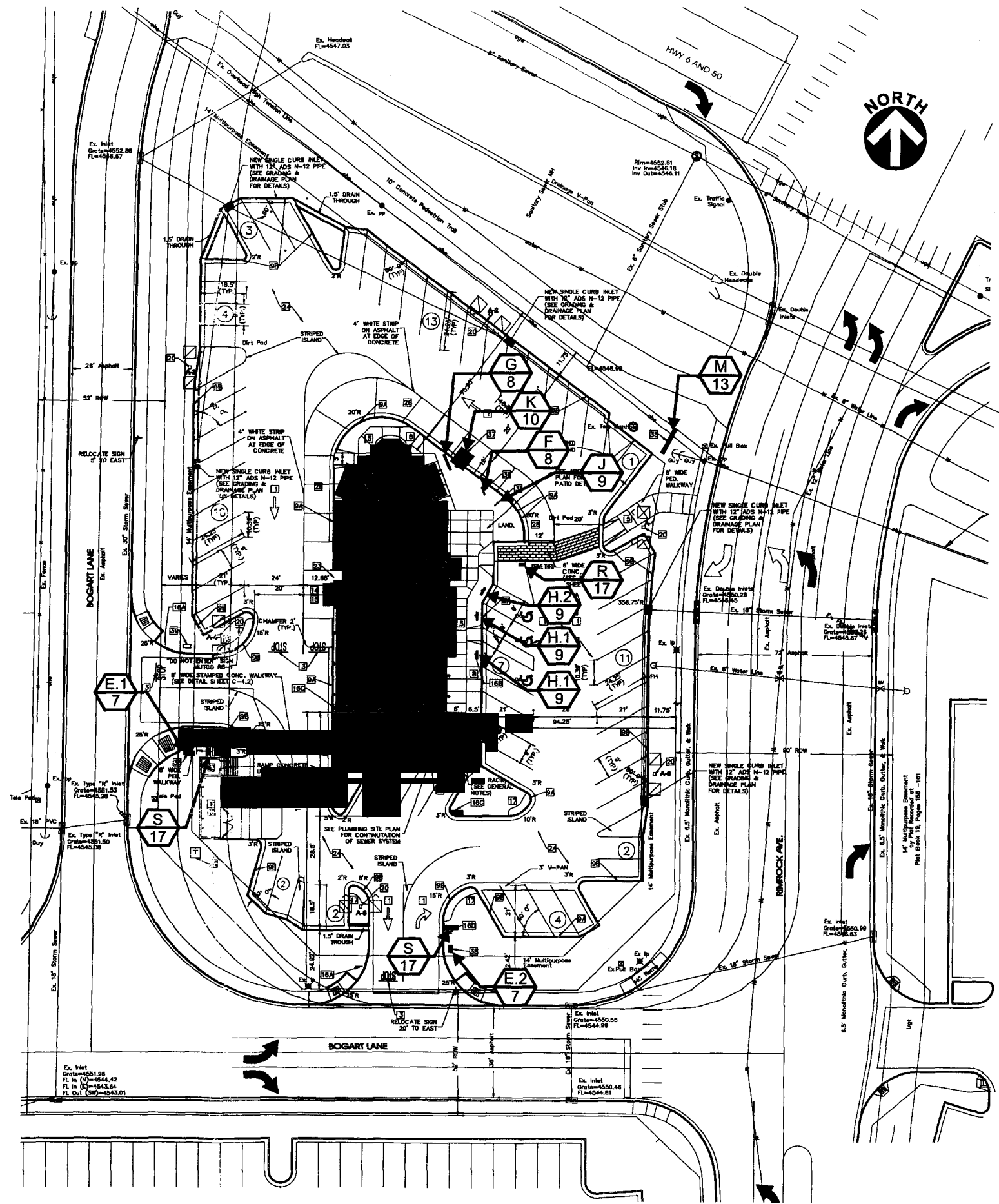

1 PRELIMINARY SITE PLAN
SCALE: N.T.S.



1700 West Anaheim Street
Long Beach, California
90813-1195
phone: 562.495.3808
facsimile: 562.435.1867

www.superiorsigns.com
design@superiorsigns.com

Project:
CHICK-FIL-A #1691

Address:
522 BOGART LANE
GRAND JUNCTION, CO

Account Manager:
GEORGE ADAMS

Designer:
MO

Scale:
AS NOTED

Design No.:
04-08-5168-03

Date:
08-13-04

Reg. No.:

Revisions:

- ▲ M.O. 8/18/04 Per redlined drawings dated 8/16/04
- ▲ M.O. 8/19/04 Add stone base specification to monument sign
- ▲ AR 10/29/04 Edit legend and flag pole height.

Page: 1 Of: 17

This is an original unpublished drawing created by Superior Electrical Advertising. It is submitted for your approval. It is not to be shown to anyone outside of your organization, nor is it to be reproduced, copied or exhibited in any fashion. The changing of colors, sizes, materials or illumination method does not alter the design. Ownership of this design is held by Superior Electrical Advertising, Inc. Authorization to use this design in any fashion must be obtained in writing from Superior Electrical Advertising, Inc.

© SEA 2004
Note: The Colors depicted here are a graphic representation. Actual colors may vary. See color specifications.



superior
electrical advertising

1700 West Anaheim Street
Long Beach, California
90813-1195
phone: 562.495.3808
facsimile: 562.435.1867

www.superiorsigns.com
design@superiorsigns.com

Project:
CHICK-FIL-A #1691

Address:
522 BOGART LANE
GRAND JUNCTION, CO

Account Manager:
GEORGE ADAMS

Designer:
MO

Scale:
AS NOTED

Design No.:
04-08-5168-03

Date:
08-13-04

Reg. No.:

Revisions:

- 1 M.O. 8/18/04 Per redlined drawings dated 8/16/04
- 2 M.O. 8/19/04 Add stone base specification to monument sign
- 3 AR 10/29/04 Edit legend and flag pole height.

Page: 3 Of: 17

This is an original unpublished drawing created by Superior Electrical Advertising. It is submitted for your approval. It is not to be shown to anyone outside of your organization, nor is it to be reproduced, copied or exhibited in any fashion. The changing of colors, sizes, materials or illumination method does not alter the design. Ownership of this design is held by Superior Electrical Advertising, Inc. Authorization to use this design in any fashion must be obtained in writing from Superior Electrical Advertising, Inc.

© SEA 2004

Note: The Colors depicted here are a graphic representation. Actual colors may vary. See color specifications.

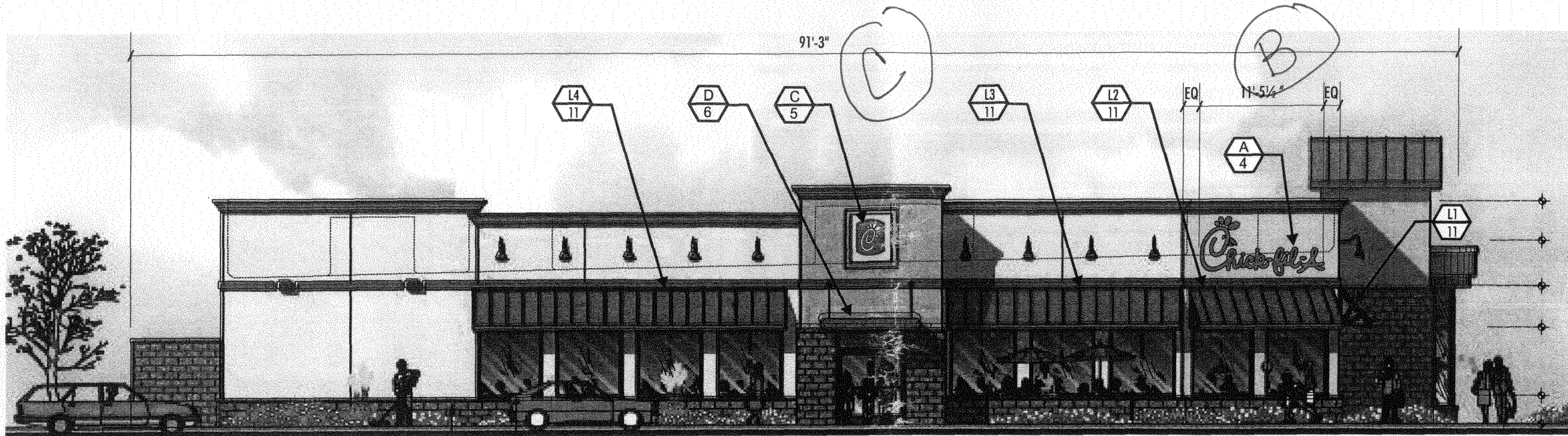

4 MAIN ENTRY ELEVATION (EAST)
SCALE: 3/32" = 1'-0"

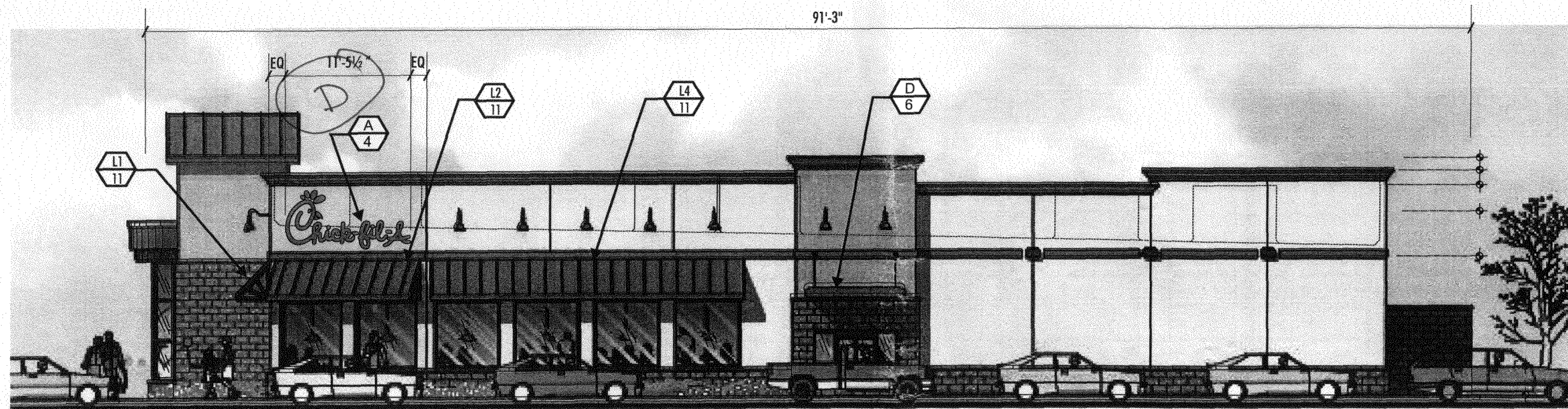

5 DRIVE-THRU ELEVATION (WEST)
SCALE: 3/32" = 1'-0"

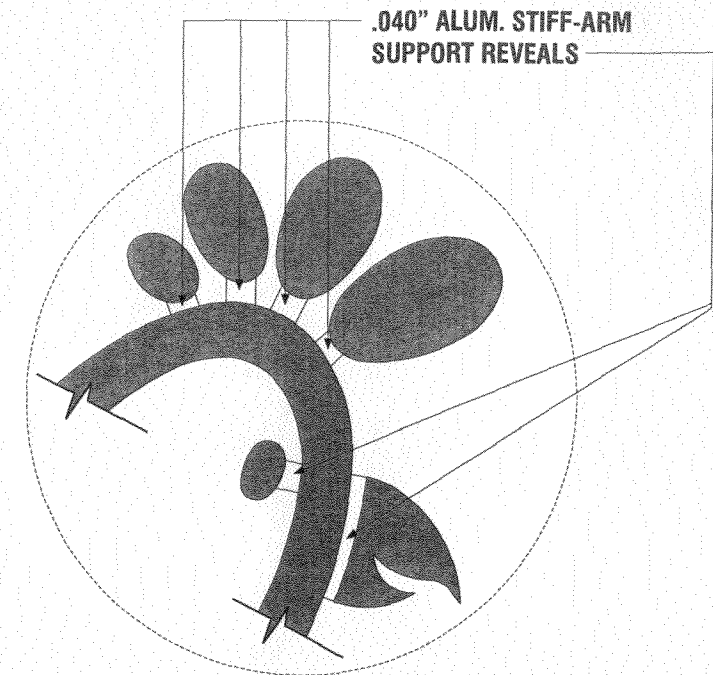
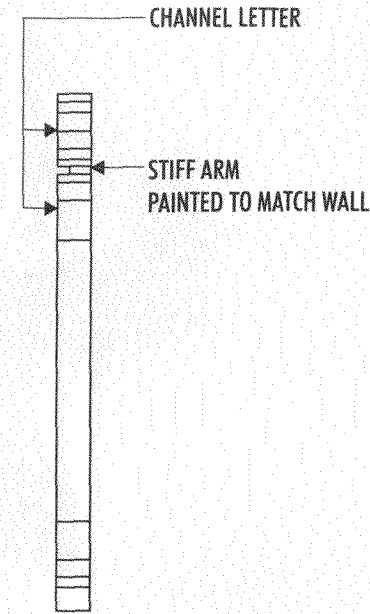
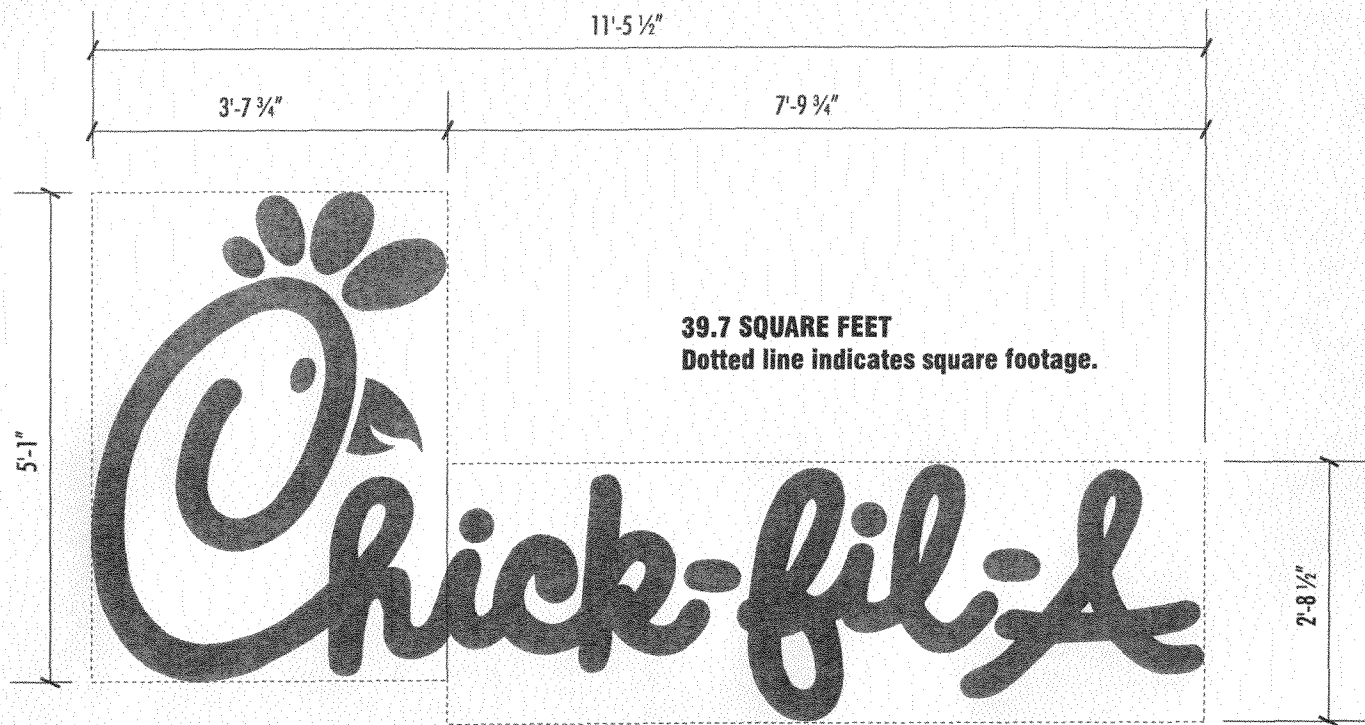

A CUSTOM FABRICATED ALUMINUM CHANNEL LETTERS WITH LED ILLUMINATION
Scale: 1/2" = 1'-0"

QTY: FOUR (4)
AREA: 39.7 SQ. FT.

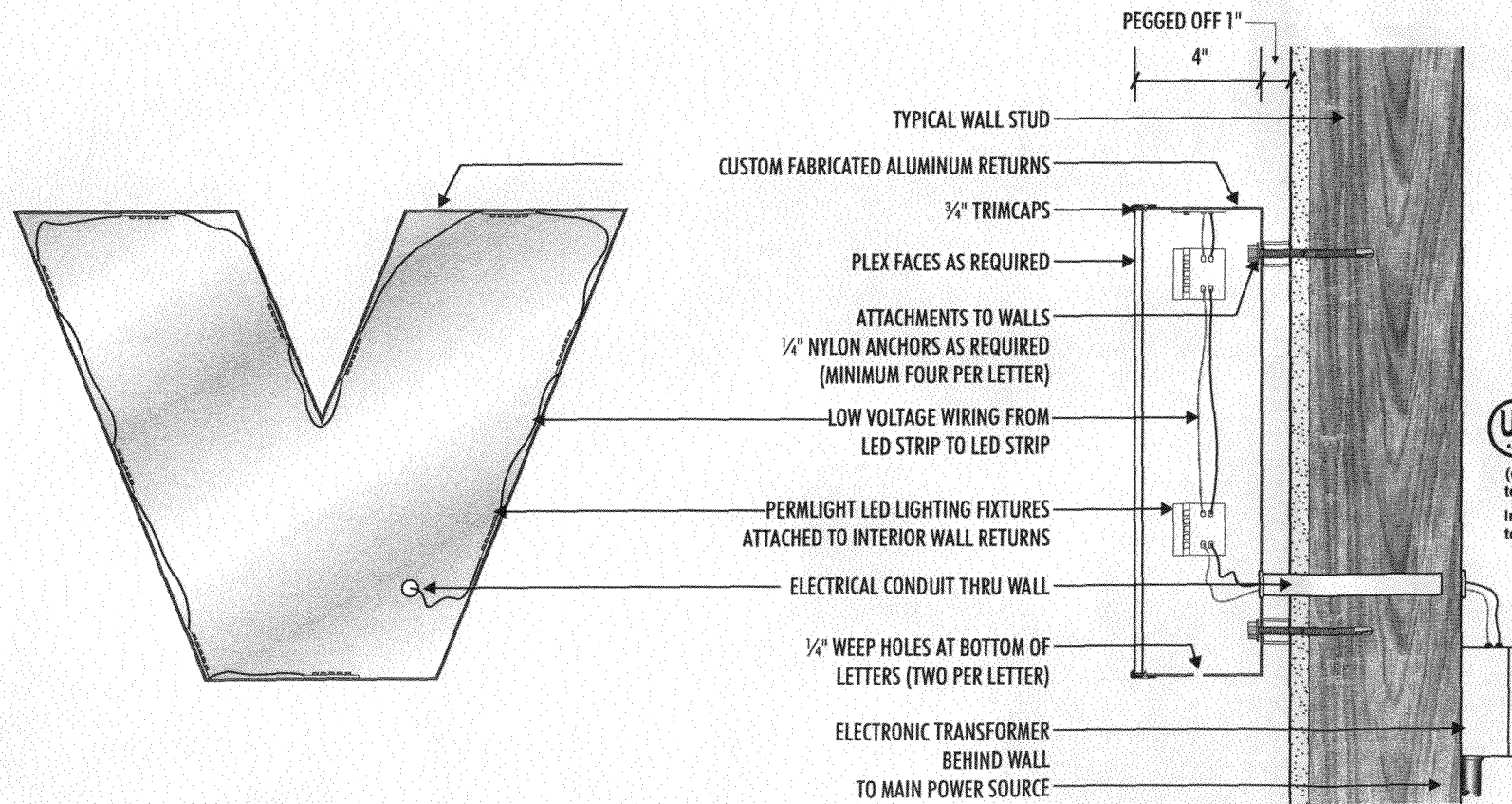

UL LISTED
(or other accredited testing laboratory)
Install in accordance to N.E.C.

SPECIFICATIONS:

ILLUMINATED INDIVIDUALLY LIT LED CHANNEL LETTERS.
LOW VOLTAGE TRANSFORMERS LOCATED BEHIND WALL.
LETTER RETURNS .050 ALUMINUM WITH .063 ALUMINUM BACKS.
FACES TO BE 3/16" ACRYLIC WITH 1" JEWELITE TRIM CAP EDGE.

FACE COLOR: RED #278-0 SG ACRYLITE
TRIM CAP COLOR: RED
RETURN COLOR: GLOSS WHITE GRIP GARD #RST584.

ALL PAINT - AKZO-NOBLE "GRIP GARD"
ACRYLIC POLYURETHANE.

TYPICAL FRONT DETAIL

TYPICAL SECTION DETAIL

6 SECTION DETAIL / CHANNEL LETTER W/ LED LIGHTING DISPLAY
SCALE: N.T.S.



superior
electrical advertising

1700 West Anaheim Street
Long Beach, California
90813-1195
phone: 562.495.3808
facsimile: 562.435.1867

www.superiorsigns.com
design@superiorsigns.com

Project:
CHICK-FIL-A #1691

Address:
522 BOGART LANE
GRAND JUNCTION, CO

Account Manager:
GEORGE ADAMS

Designer:
MO

Scale:
AS NOTED

Design No.:
04-08-5168-03

Date:
08-13-04

Reg. No.:

Revisions:

- 1 M.O. 8/18/04 Per redlined drawings dated 8/16/04
- 2 M.O. 8/19/04 Add stone base specification to monument sign
- 3 AR 10/29/04 Edit legend and flag pole height.

Page: 4 Of: 17

This is an original unpublished drawing created by Superior Electrical Advertising. It is submitted for your approval. It is not to be shown to anyone outside of your organization, nor is it to be reproduced, copied or exhibited in any fashion. The changing of colors, sizes, materials or illumination method does not alter the design. Ownership of this design is held by Superior Electrical Advertising, Inc. Authorization to use this design in any fashion must be obtained in writing from Superior Electrical Advertising, Inc.

© SEA 2004

Note: The Colors depicted here are a graphic representation. Actual colors may vary. See color specifications.

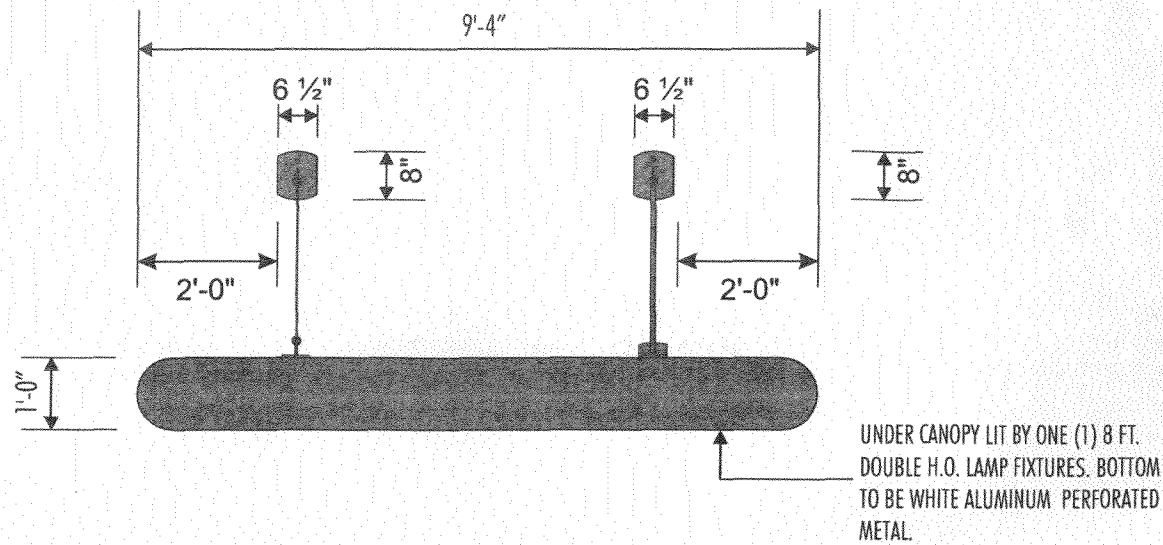

D FRONT ELEVATION ALUMINUM FABRICATED AWNINGS W/ UNDER CANOPY LIGHTING QTY: TWO (2)
SCALE: 3/8" = 1'-0"

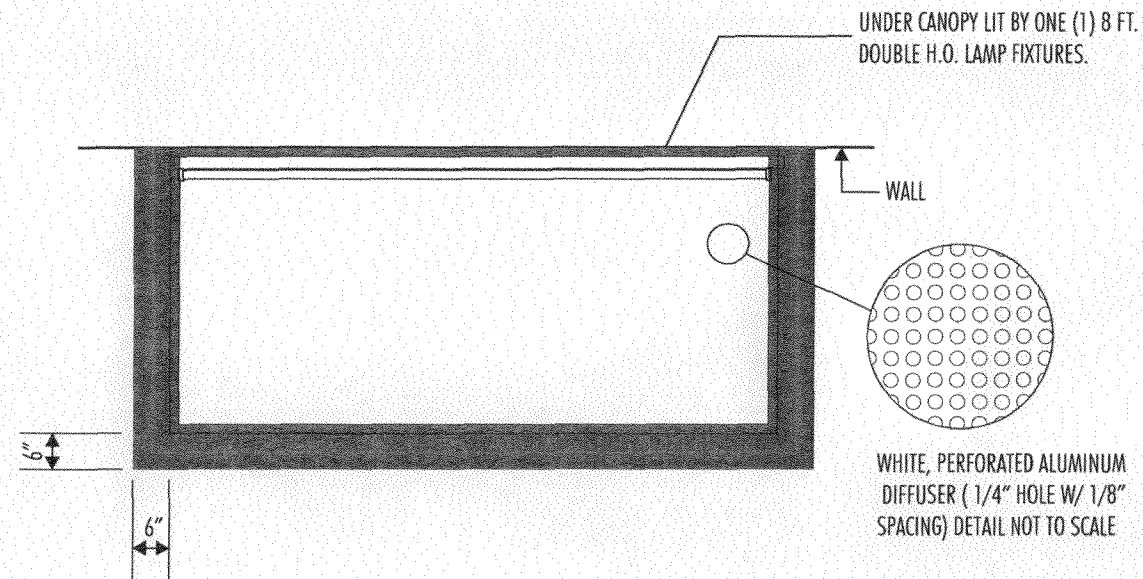

8 BOTTOM VIEW SCALE: 3/8" = 1'-0"

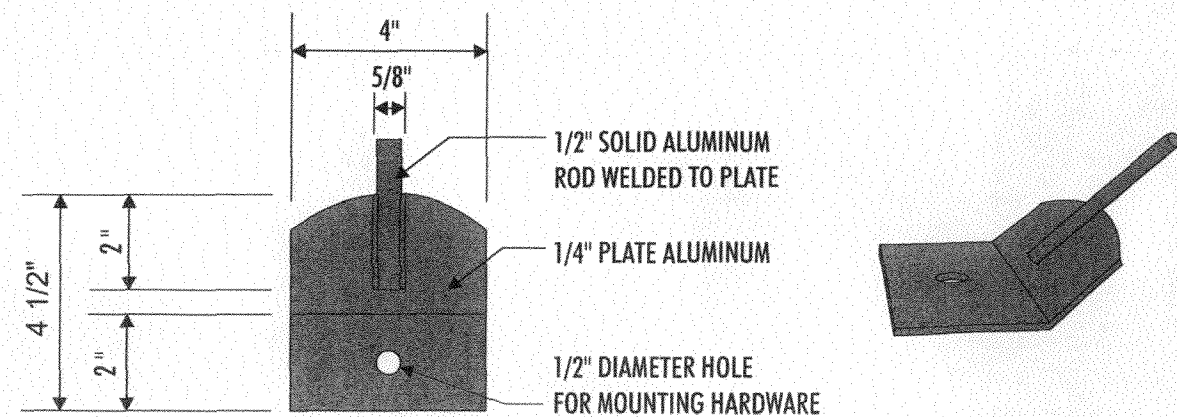

9 DETAIL B SCALE - 3" = 1'-0"

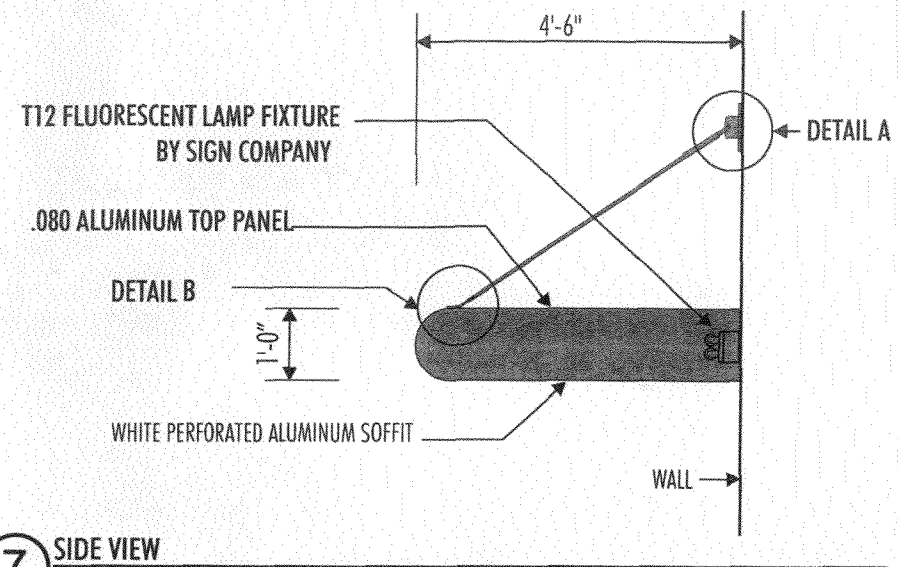

7 SIDE VIEW SCALE: 3/8" = 1'-0"

NOTE: ALL SUPPORT HARDWARE TO BE ALUMINUM PAINTED RED TO MATCH THE CANOPY EXCEPT FOR CLEVIS

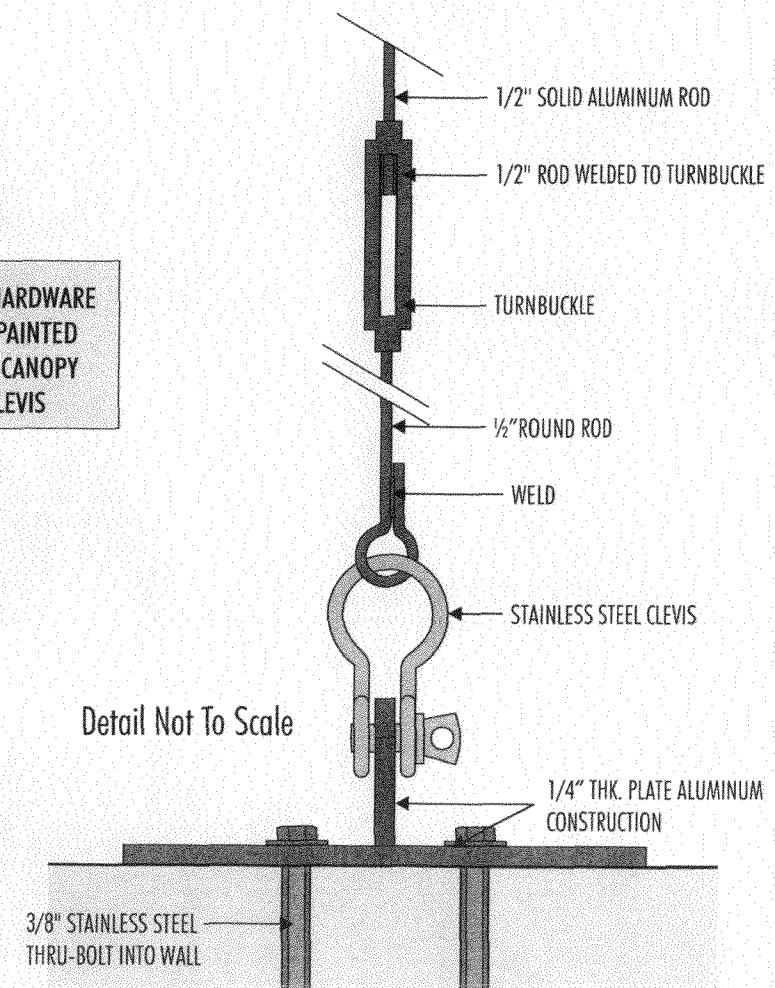

10 DETAIL A NOT TO SCALE



1700 West Anaheim Street
Long Beach, California
90813-1195
phone: 562.495.3808
facsimile: 562.435.1867

www.superiorsigns.com
design@superiorsigns.com

Project:
CHICK-FIL-A #1691

Address:
522 BOGART LANE
GRAND JUNCTION, CO

Account Manager:
GEORGE ADAMS

Designer:
MO

Scale:
AS NOTED

Design No.:
04-08-5168-03

Date:
08-13-04

Reg. No.:

Revisions:

- 1 M.O. 8/18/04 Per redlined drawings dated 8/16/04
- 2 M.O. 8/19/04 Add stone base specification to monument sign
- 3 AR 10/29/04 Edit legend and flag pole height.

Page: Of:
6 17

This is an original unpublished drawing created by Superior Electrical Advertising. It is submitted for your approval. It is not to be shown to anyone outside of your organization, nor is it to be reproduced, copied or exhibited in any fashion. The changing of colors, sizes, materials or illumination method does not alter the design. Ownership of this design is held by Superior Electrical Advertising, Inc. Authorization to use this design in any fashion must be obtained in writing from Superior Electrical Advertising, Inc.

© SEA 2004

Note: The Colors depicted here are a graphic representation. Actual colors may vary. See color specifications.

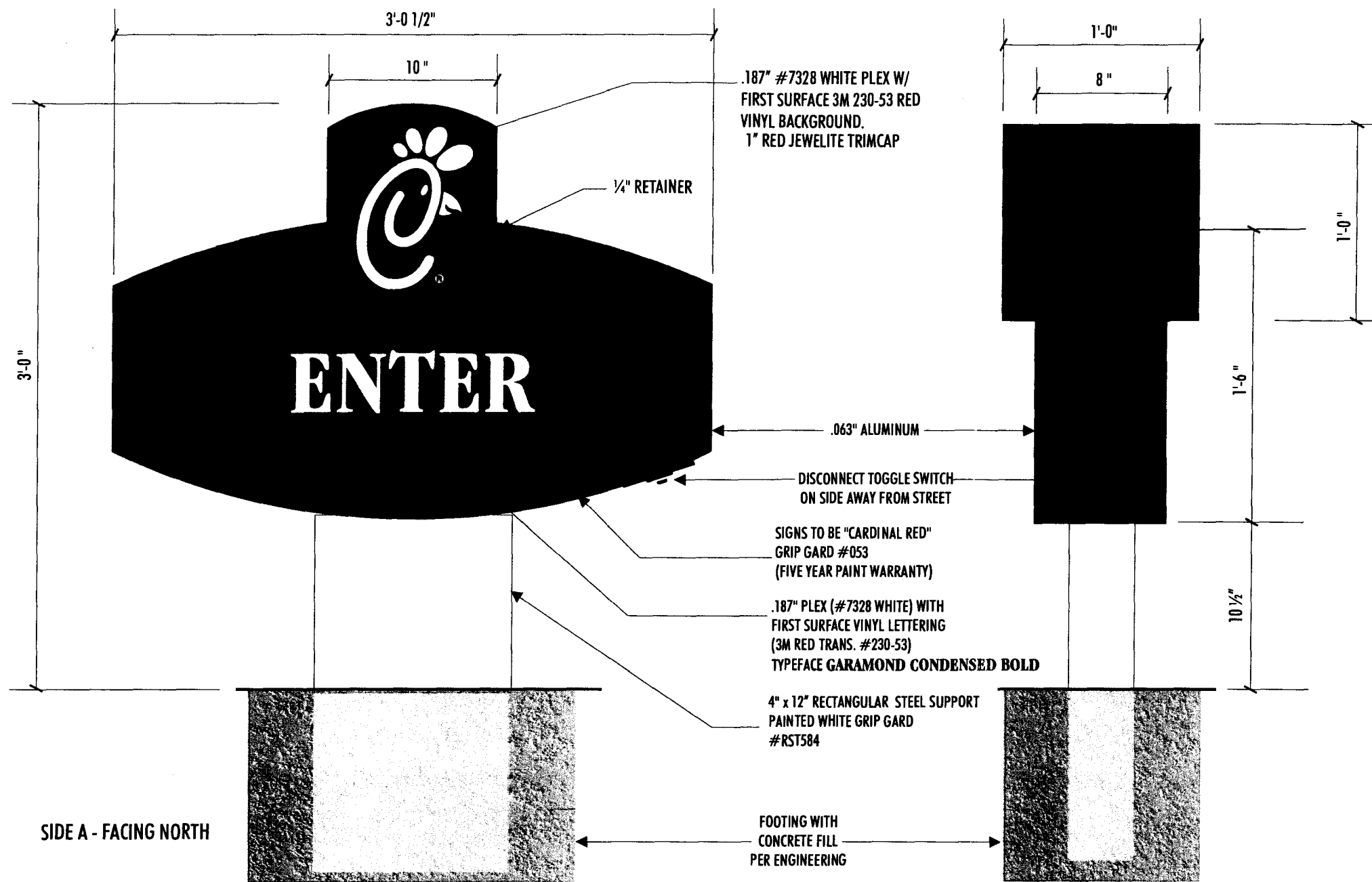

E.1 DOUBLE FACE DIRECTIONAL SIGN
SIDE B - FACING SOUTH



E.2 DOUBLE FACE DIRECTIONAL SIGN
SIDE A - FACING NORTH



E.2 DOUBLE FACE DIRECTIONAL SIGN
SIDE B - FACING SOUTH

E.1 CUSTOM FABRICATED ALUMINUM DOUBLE FACE DIRECTIONAL SIGN
SCALE: 1 1/2" = 1'-0" AREA: 4 SQ. FT.

SIGNS TO BE FABRICATED OF .063" AND .080" ALUMINUM WITH NO VISIBLE FASTENERS, PRIMED AND PAINTED WITH ACRYLIC POLYURETHANE (AKZO NOBEL "GRIP GARD"). SIGNS TO BE INTERNALLY ILLUMINATED WITH 800 MA LAMPS (36" DAYLIGHT) ON 12" HORIZONTAL. U.L APPROVED 120 VOLTS - AC WITH 6G901 BALLAST.

MAKE ONE (1) TYPE E.1 "THANK YOU" / "DO NOT ENTER"
MAKE TWO (2) TYPE E.2 "ENTER" / "ENTER"



1700 West Anaheim Street
Long Beach, California
90813-1195
phone: 562.495.3808
facsimile: 562.435.1867

www.superiorsigns.com
design@superiorsigns.com

Project:
CHICK-FIL-A #1691

Address:
522 BOGART LANE
GRAND JUNCTION, CO

Account Manager:
GEORGE ADAMS

Designer:
MO

Scale:
AS NOTED

Design No.:
04-08-5168-03

Date:
08-13-04

Reg. No.:

Revisions:

- △ M.O. 8/18/04 Per redlined drawings dated 8/16/04
- △ M.O. 8/19/04 Add stone base specification to monument sign
- △ AR 10/29/04 Edit legend and flag pole height.

Page: 7 Of: 17

This is an original unpublished drawing created by Superior Electrical Advertising. It is submitted for your approval. It is not to be shown to anyone outside of your organization, nor is it to be reproduced, copied or exhibited in any fashion. The changing of colors, sizes, materials or illumination method does not alter the design. Ownership of this design is held by Superior Electrical Advertising, Inc. Authorization to use this design in any fashion must be obtained in writing from Superior Electrical Advertising, Inc.

© SEA 2004
Note: The Colors depicted here are a graphic representation. Actual colors may vary. See color specifications.

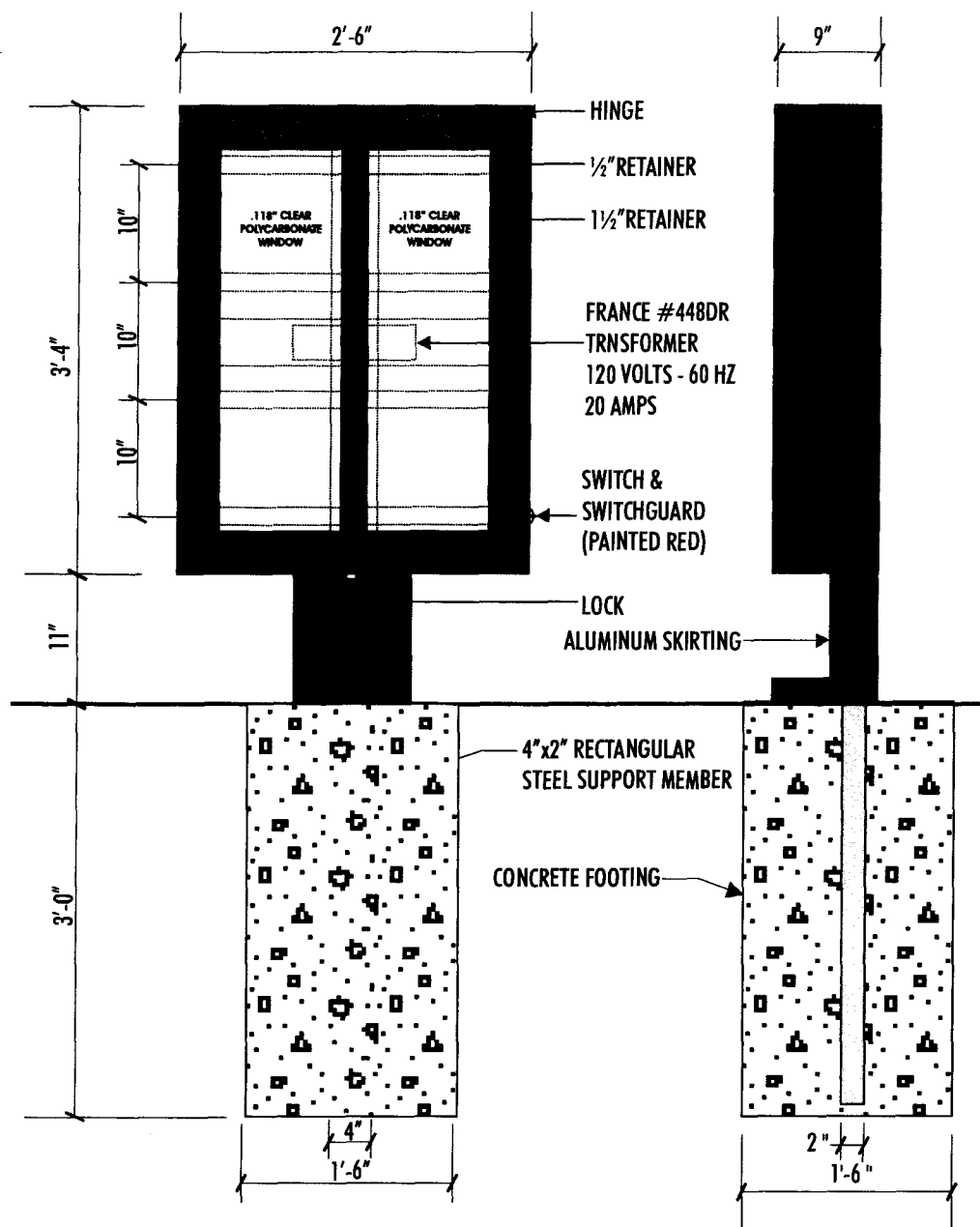

F SINGLE FACE PRE MENU BOARD SIGN (BY OTHERS)
 SCALE: 3/4" = 1'-0"
 QTY: ONE (1)
 AREA: 8.3 SQ. FT.

SPECIFICATIONS:

SIGN FRAME:
 9" WIDE .063" ALUMINUM FILLER AND RETAINER PAINTED RED (FIVE YEAR WARRANTY).
 SERVICE THROUGH FRONT HINGED LEXAN COVER. 2" x 2" DOUBLE ANGLE ALUMINUM FRAMEWORK

ELECTRICAL:
 ALL ELECTRICAL COMPONENTS U.L. LISTED, SIGN TO BEAR U.L. LABEL.
 ALL LAMPS 800 MA ON 10" CENTERS, HORIZONTALLY.
 CURRENT REQUIREMENTS - 15 AMPS

FACES:
 MATERIAL COVER .220" LEXAN, ITEM COMPONENTS.
 ALUMINUM EXTRUSION WITH LEXAN INSERTS

WIND LOAD:
 DESIGNED FOR 30 PSI WIND LOAD.

COLORS:
 1. CARDINAL RED - GRIP GARD #053
 2. WHITE - GRIP GARD #RST584

INSTALL ONLY

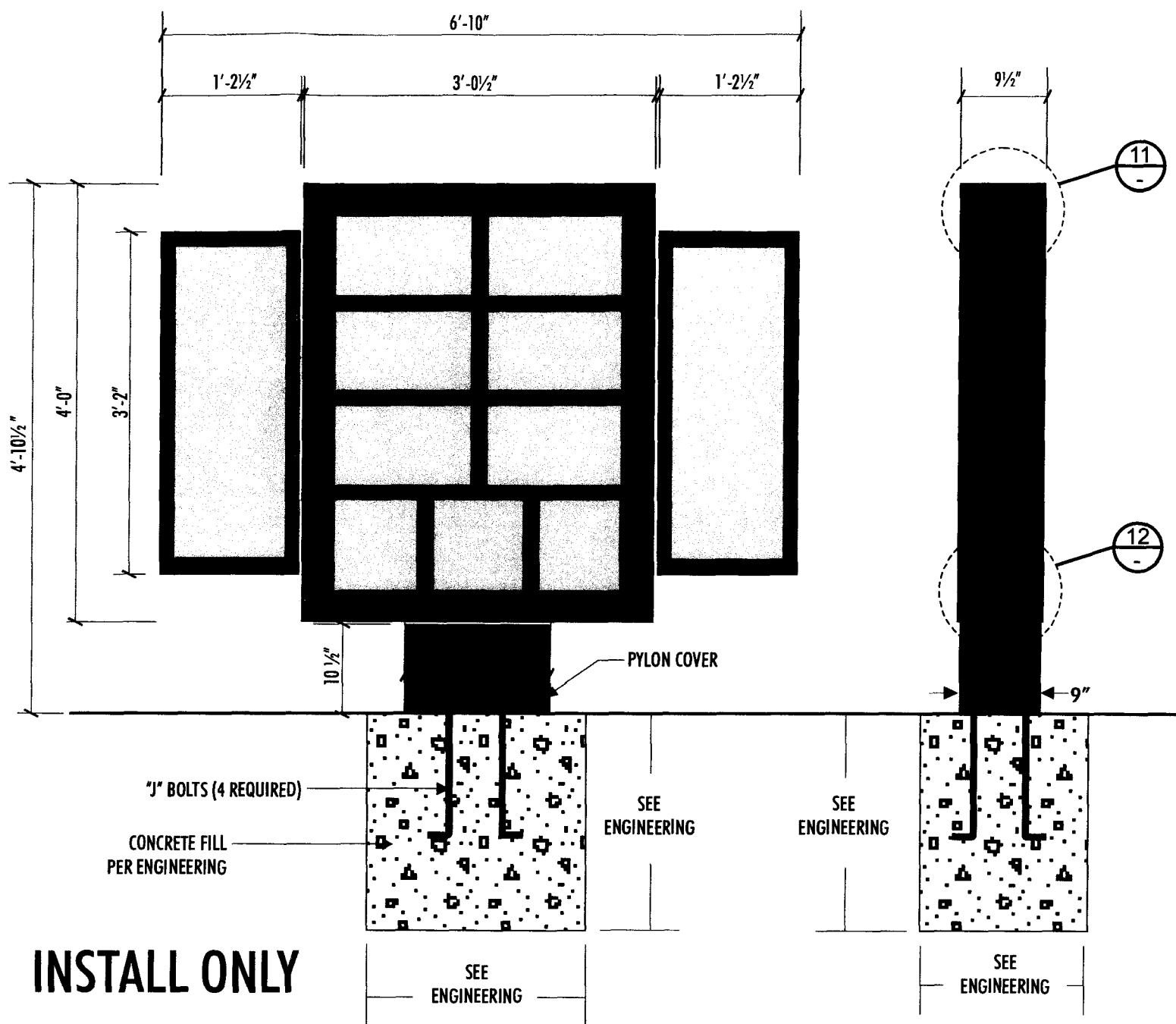

INSTALL ONLY

G SINGLE FACE MENU BOARD SIGN (BY OTHERS)
 SCALE: N.T.S.
 QTY: ONE (1)
 AREA: 23.3 SQ. FT.

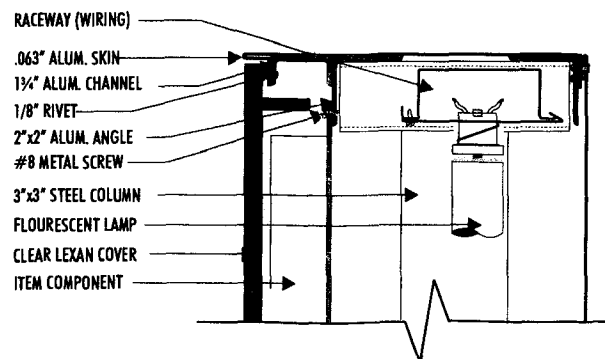

11 DETAIL
 SCALE: N.T.S.

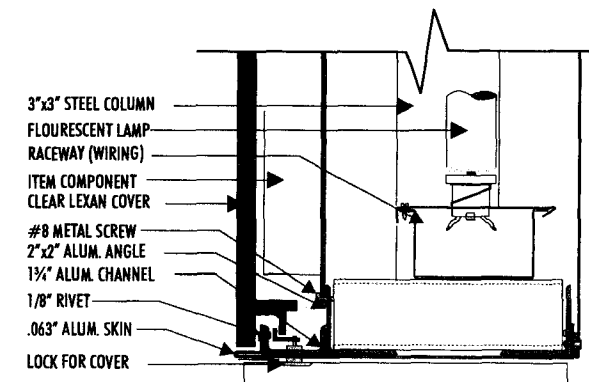

12 DETAIL
 SCALE: N.T.S.



1700 West Anaheim Street
 Long Beach, California
 90813-1195
 phone: 562.495.3808
 facsimile: 562.435.1867

www.superiorsigns.com
 design@superiorsigns.com

Project:
 CHICK-FIL-A #1691

Address:
 522 BOGART LANE
 GRAND JUNCTION, CO

Account Manager:
 GEORGE ADAMS

Designer:
 MO

Scale:
 AS NOTED

Design No.:
 04-08-5168-03

Date:
 08-13-04

Reg. No.:

Revisions:

- 1 M.O. 8/18/04 Per redlined drawings dated 8/16/04
- 2 M.O. 8/19/04 Add stone base specification to monument sign
- 3 AR 10/29/04 Edit legend and flag pole height.

Page: 8 Of: 17

This is an original unpublished drawing created by Superior Electrical Advertising. It is submitted for your approval. It is not to be shown to anyone outside of your organization, nor is it to be reproduced, copied or exhibited in any fashion. The changing of colors, sizes, materials or illumination method does not alter the design. Ownership of this design is held by Superior Electrical Advertising, Inc. Authorization to use this design in any fashion must be obtained in writing from Superior Electrical Advertising, Inc.

© SEA 2004
 Note: The Colors depicted here are a graphic representation. Actual colors may vary. See color specifications.

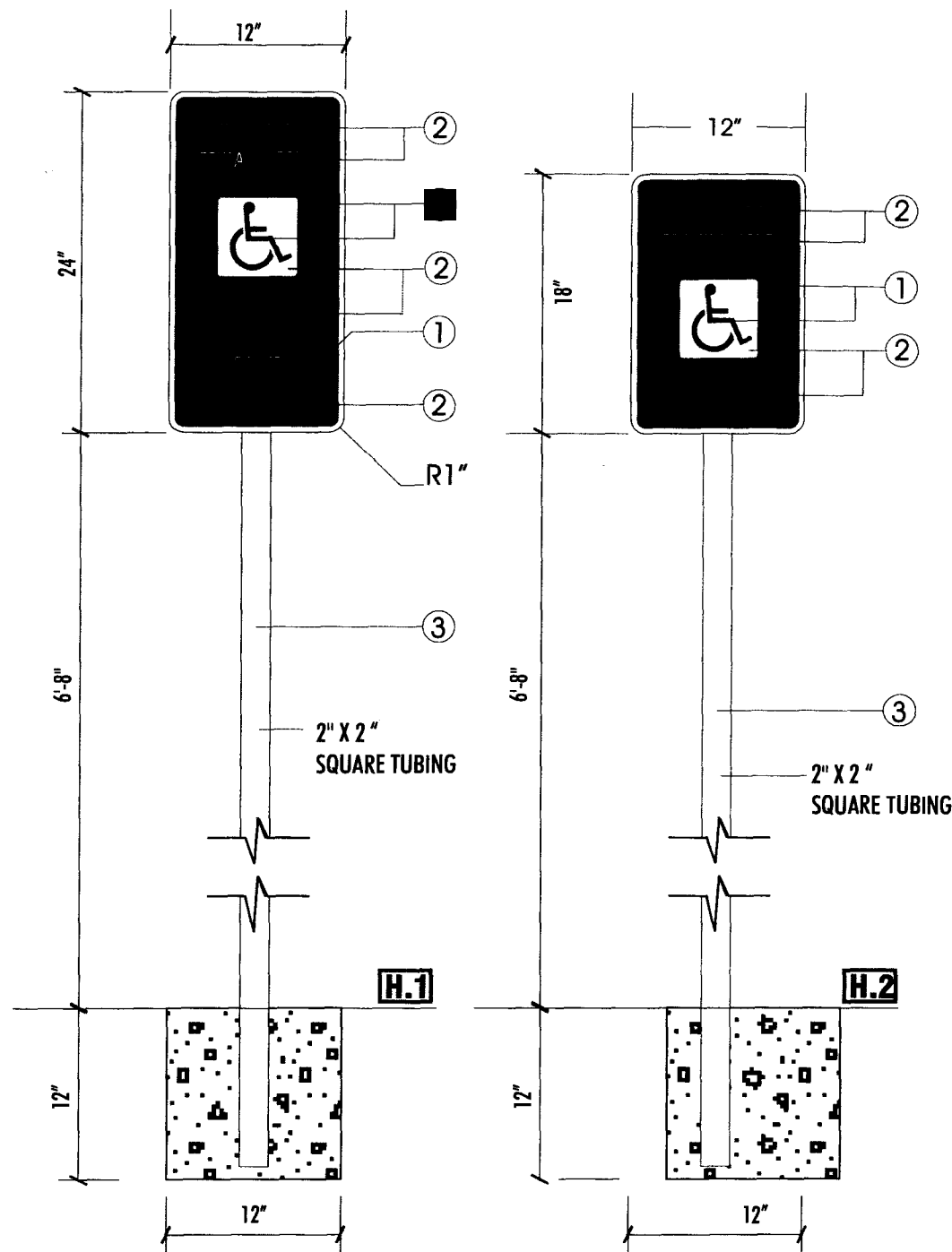

H HANDICAPPED PARKING SIGN
SCALE: 1" = 1'-0"
QUANTITY: THREE(3)

NOTES:

SIGNS ARE TO BE S/F .080 NON-ILLUMINATED GRAPHICS APPLIED FIRST SURFACE LETTER STYLE HELVETICA MEDIUM

COLOR PLACEMENT:

1. BLUE "REFLECTIVE"
2. WHITE "REFLECTIVE"
3. PAINT: AKZO-NOBEL "GRIP GARD" ACRYLIC POLYURETHANE WHITE #RST584

NOTE: VERIFY COLORS WITH LOCAL MUNICIPALITY

1 REQUIRED WITH "VAN" PANEL

2 REQUIRED WITH NO "VAN" PANEL

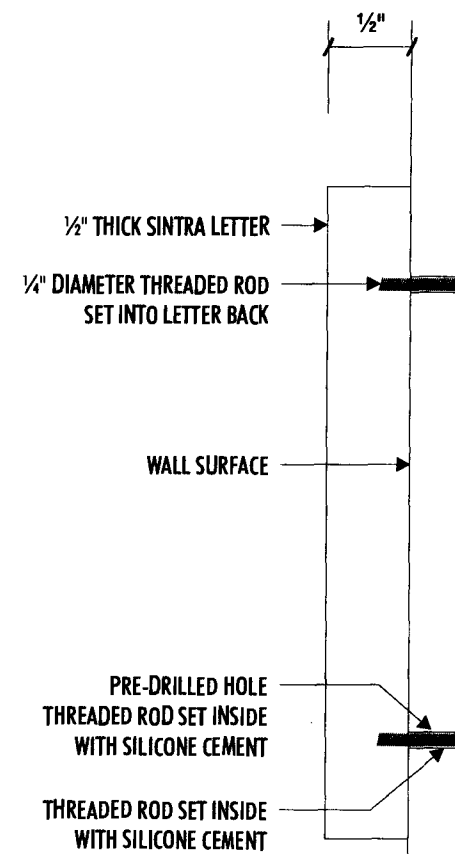

13 NON-ILLUMINATED SINTRA LETTERS SECTION VIEW DETAIL
Scale: NTS

1'-0"
522

1 NON-ILLUMINATED SINTRA LETTERS QTY: ONE (1) SET
SCALE: 1 1/2" = 1'-0"

SPECIFICATIONS:

LETTERS: 1/2" THICK NON-ILLUMINATED SINTRA LETTERS PAINTED RED TO MATCH #278-0 RED SG ACRYLITE

ALL PAINT: AKSO-NOBEL "GRIP GARD" ACRYLIC POLYURETHANE
INSTALLATION: 1/4" DIAMETER THREADED RODS INTO LETTER BACKS AND SET INTO PRE-DRILLED HOLES WITH SILICONE CEMENT

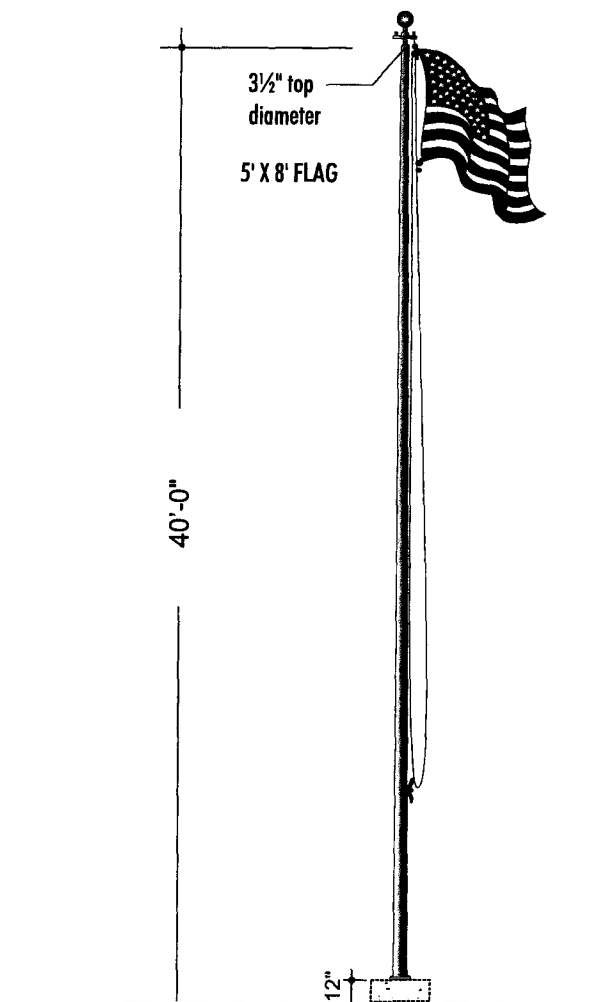

J FLAG POLE
SCALE: N.T.S. QTY: ONE (1)

INSTALL ONLY



1700 West Anaheim Street
Long Beach, California
90813-1195
phone: 562.495.3808
facsimile: 562.435.1867

www.superiorsigns.com
design@superiorsigns.com

Project:
CHICK-FIL-A #1691

Address:
522 BOGART LANE
GRAND JUNCTION, CO

Account Manager:
GEORGE ADAMS

Designer:
MO

Scale:
AS NOTED

Design No.:
04-08-5168-03

Date:
08-13-04

Reg. No.:

Revisions:

- △ M.O. 8/18/04 Per redlined drawings dated 8/16/04
- △ M.O. 8/19/04 Add stone base specification to monument sign
- △ AR 10/29/04 Edit legend and flag pole height.

Page: 9 Of: 17

This is an original unpublished drawing created by Superior Electrical Advertising. It is submitted for your approval. It is not to be shown to anyone outside of your organization, nor is it to be reproduced, copied or exhibited in any fashion. The changing of colors, sizes, materials or illumination method does not alter the design. Ownership of this design is held by Superior Electrical Advertising, Inc. Authorization to use this design in any fashion must be obtained in writing from Superior Electrical Advertising, Inc.

© SEA 2004

Note: The Colors depicted here are a graphic representation. Actual colors may vary. See color specifications.

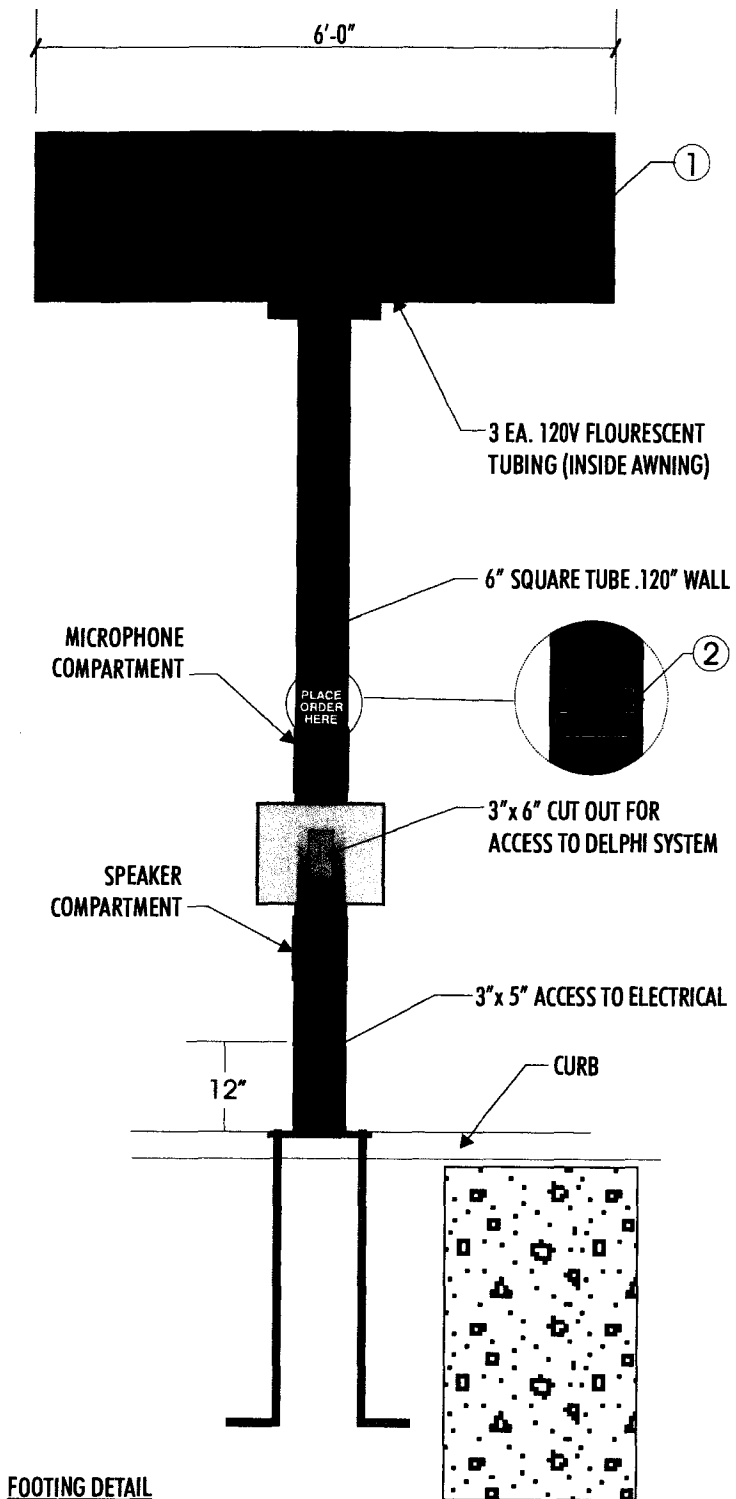
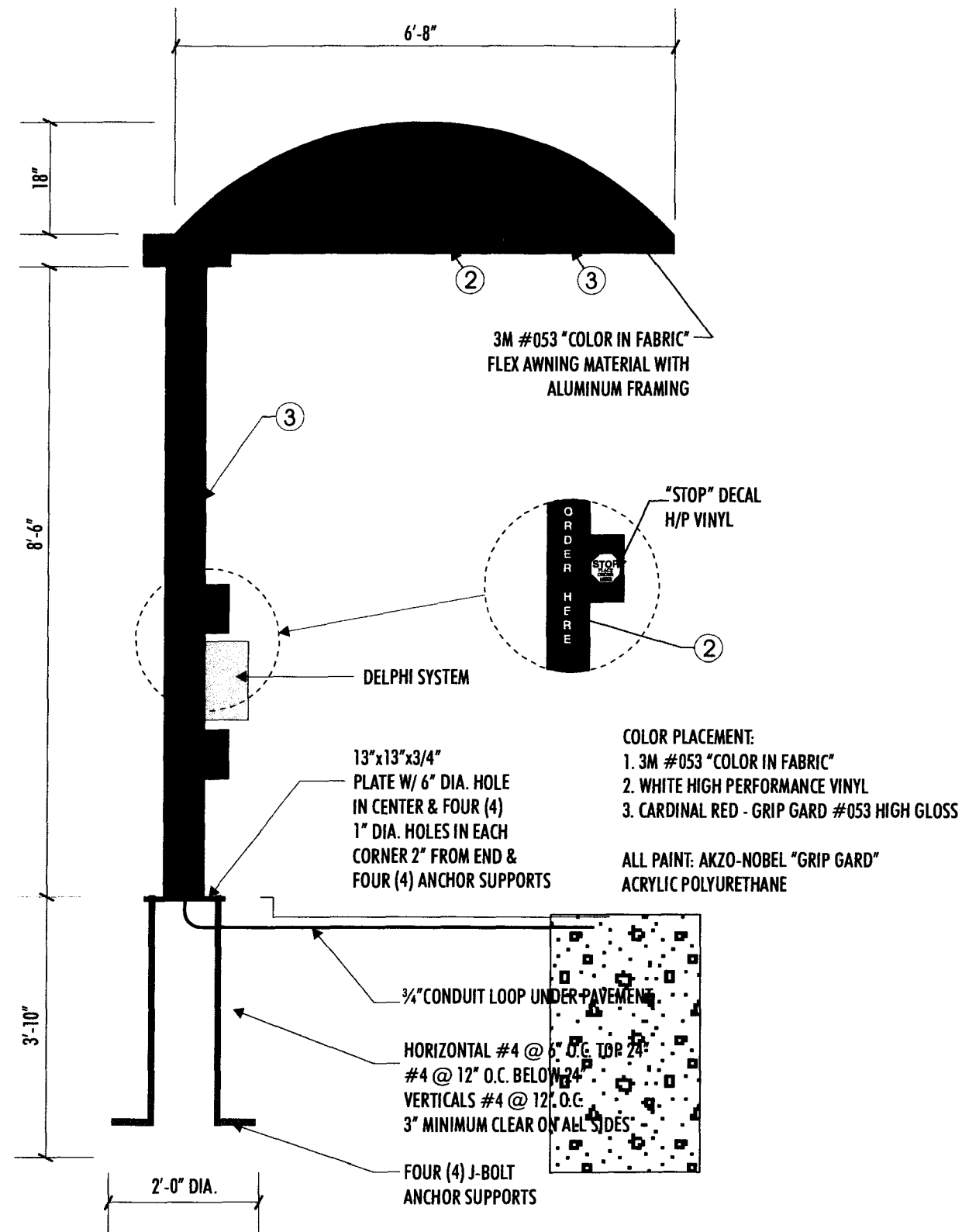

K CANOPY SYSTEM (BY OTHERS)
SCALE: 1/2" = 1'-0"

QTY: ONE (1)

INSTALL ONLY



1700 West Anaheim Street
Long Beach, California
90813-1195
phone: 562.495.3808
facsimile: 562.435.1867

www.superiorsigns.com
design@superiorsigns.com

Project:
CHICK-FIL-A #1691

Address:
522 BOGART LANE
GRAND JUNCTION, CO

Account Manager:
GEORGE ADAMS

Designer:
MO

Scale:
AS NOTED

Design No.:
04-08-5168-03

Date:
08-13-04

Reg. No.:

Revisions:

- △ M.O. 8/18/04 Per redlined drawings dated 8/16/04
- △ M.O. 8/19/04 Add stone base specification to monument sign
- △ AR 10/29/04 Edit legend and flag pole height.

Page: 10 Of: 17

This is an original unpublished drawing created by Superior Electrical Advertising, Inc. It is submitted for your approval. It is not to be shown to anyone outside of your organization, nor is it to be reproduced, copied or exhibited in any fashion. The changing of colors, sizes, materials or illumination method does not alter the design. Ownership of this design is held by Superior Electrical Advertising, Inc. Authorization to use this design in any fashion must be obtained in writing from Superior Electrical Advertising, Inc.

© SEA 2004

Note: The Colors depicted here are a graphic representation. Actual colors may vary. See color specifications.



1700 West Anaheim Street
 Long Beach, California
 90813-1195
 phone: 562.495.3808
 facsimile: 562.435.1867

www.superiorsigns.com
 design@superiorsigns.com

Project:
 CHICK-FIL-A #1691

Address:
 522 BOGART LANE
 GRAND JUNCTION, CO

Account Manager:
 GEORGE ADAMS

Designer:
 MO

Scale:
 AS NOTED

Design No.:
 04-08-5168-03

Date:
 08-13-04

Reg. No.:

Revisions:

- 1 M.O. 8/18/04 Per redlined drawings dated 8/16/04
- 2 M.O. 8/19/04 Add stone base specification to monument sign
- 3 AR 10/29/04 Edit legend and flag pole height.

Page: 11 Of: 17

This is an original unpublished drawing created by Superior Electrical Advertising. It is submitted for your approval. It is not to be shown to anyone outside of your organization, nor is it to be reproduced, copied or exhibited in any fashion. The changing of colors, sizes, materials or illumination method does not alter the design. Ownership of this design is held by Superior Electrical Advertising, Inc. Authorization to use this design in any fashion must be obtained in writing from Superior Electrical Advertising, Inc.

© SEA 2004
 Note: The Colors depicted here are a graphic representation. Actual colors may vary. See color specifications.

	PRODUCT ID.	TYPE	QTY.	HEIGHT	WIDTH	DEPTH
LARGE BUILDING	M1	AWNING	2	2'-10"	5'-0"	3'-0"
	M2	AWNING	2	2'-10"	13'-6"	3'-0"
	M3	AWNING	1	2'-10"	21'-0"	3'-0"
	M4	AWNING	2	2'-10"	28'-6"	3'-0"
	D	BULLNOSE AWNING	2	1'-0"	9'-4"	4'-6"
	B	FRONT CANOPY	1	3'-6 1/2"	12'-6"	4'-0"
	M7	BARREL ROOF	1			

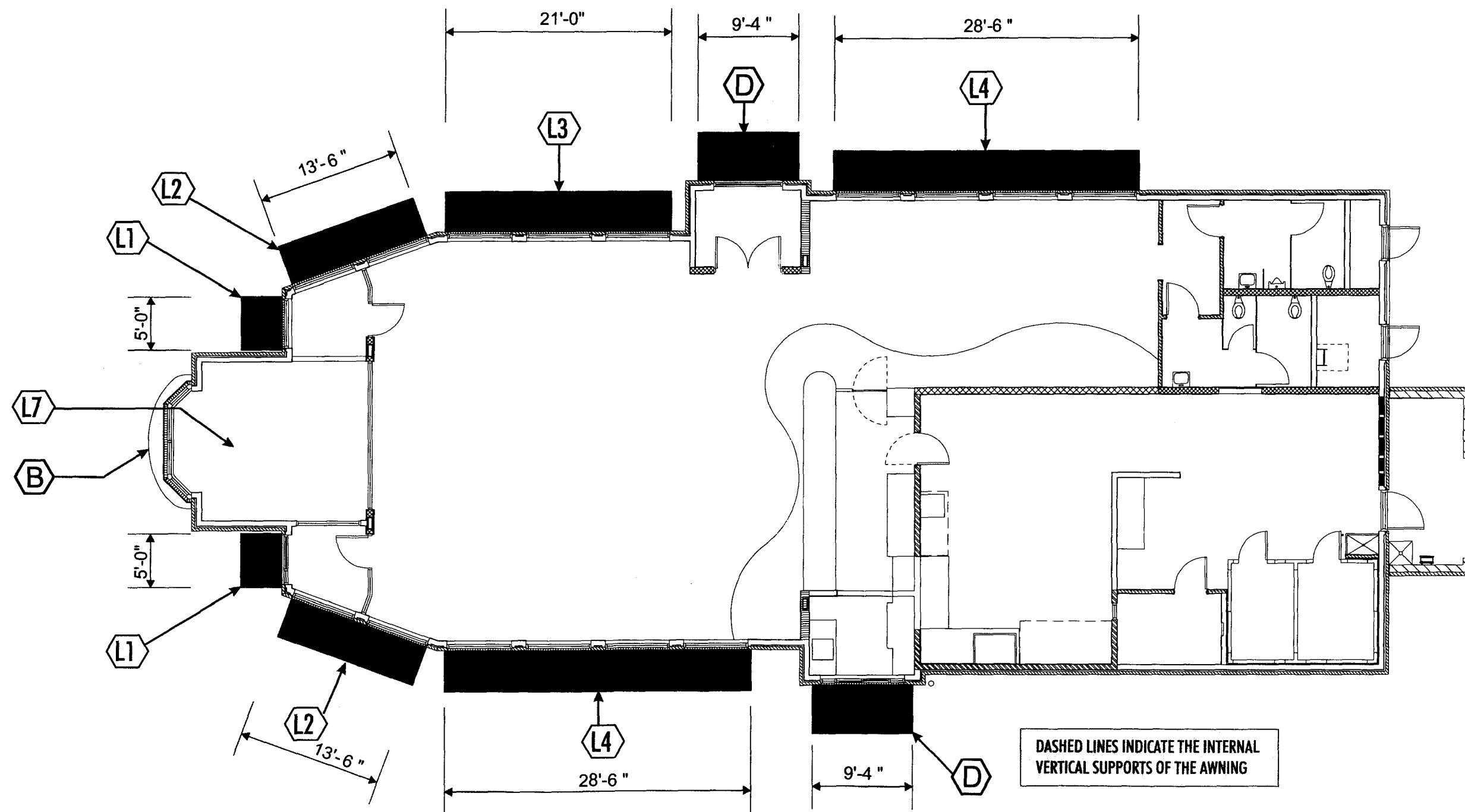

BUILDING PLAN VIEW - LARGE BUILDING

SCALE - 3/32" = 1'-0"

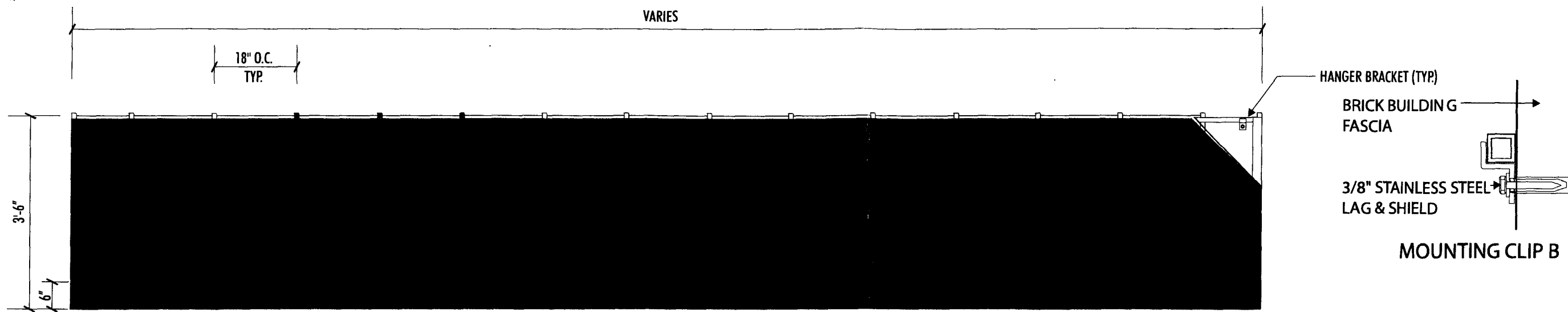

AWNING ELEVATION
SCALE: 1/2" = 1'-0"



superior
electrical advertising
1700 West Anaheim Street
Long Beach, California
90813-1195
phone: 562.495.3808
facsimile: 562.435.1867

www.superiorsigns.com
design@superiorsigns.com

Project:
CHICK-FIL-A #1691

Address:
522 BOGART LANE
GRAND JUNCTION, CO

Account Manager:
GEORGE ADAMS

Designer:
MO

Scale:
AS NOTED

Design No.:
04-08-5168-03

Date:
08-13-04

Reg. No.:

Revisions:

- △ M.O. 8/18/04 Per redlined drawings dated 8/16/04
- △ M.O. 8/19/04 Add stone base specification to monument sign
- △ AR 10/29/04 Edit legend and flag pole height.

Page: 12 Of: 17

This is an original unpublished drawing created by Superior Electrical Advertising. It is submitted for your approval. It is not to be shown to anyone outside of your organization, nor is it to be reproduced, copied or exhibited in any fashion. The changing of colors, sizes, materials or illumination method does not alter the design. Ownership of this design is held by Superior Electrical Advertising, Inc. Authorization to use this design in any fashion must be obtained in writing from Superior Electrical Advertising, Inc.

© SEA 2004
Note: The Colors depicted here are a graphic representation. Actual colors may vary. See color specifications.

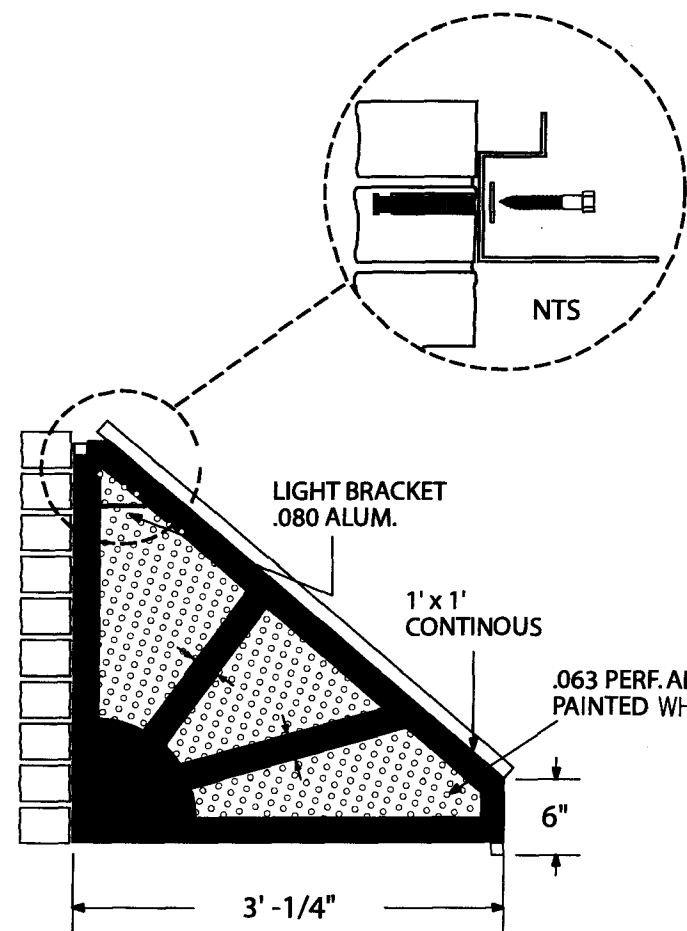

AWNING END VIEW
NOT TO SCALE

Panel
ALX-PAC-18

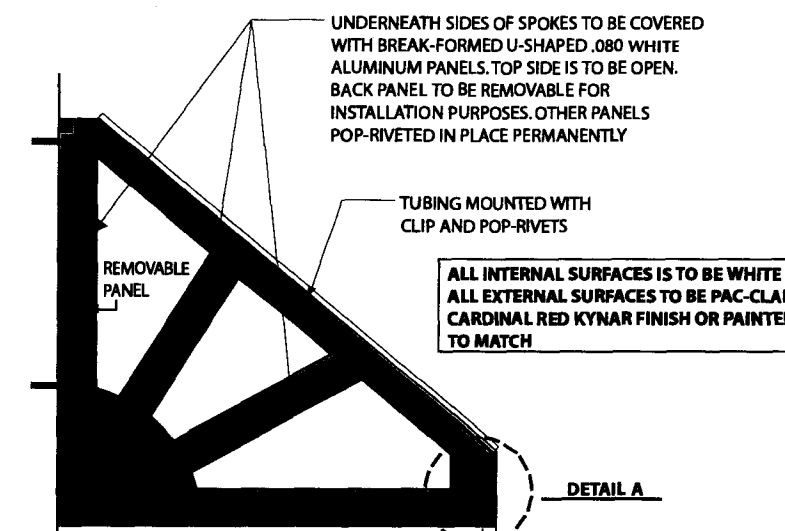
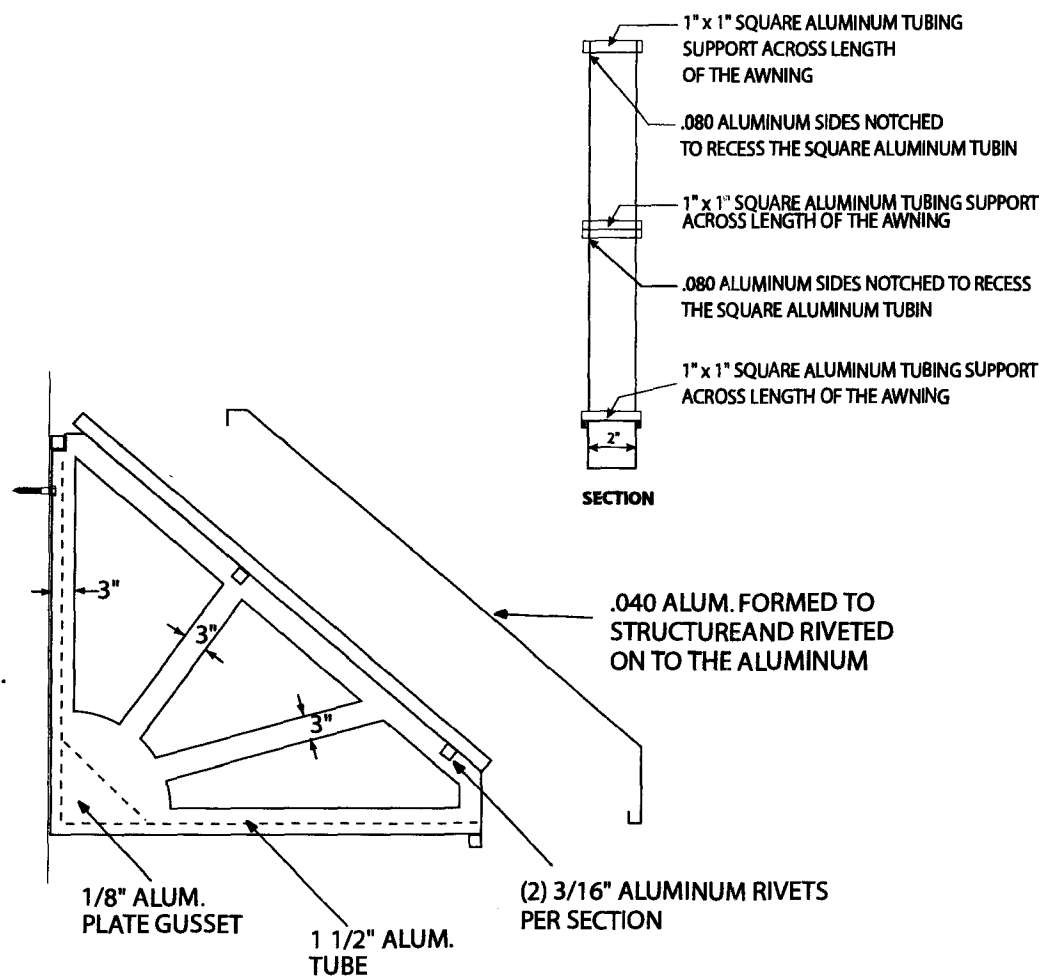

12 AWNING END VIEW
NOT TO SCALE

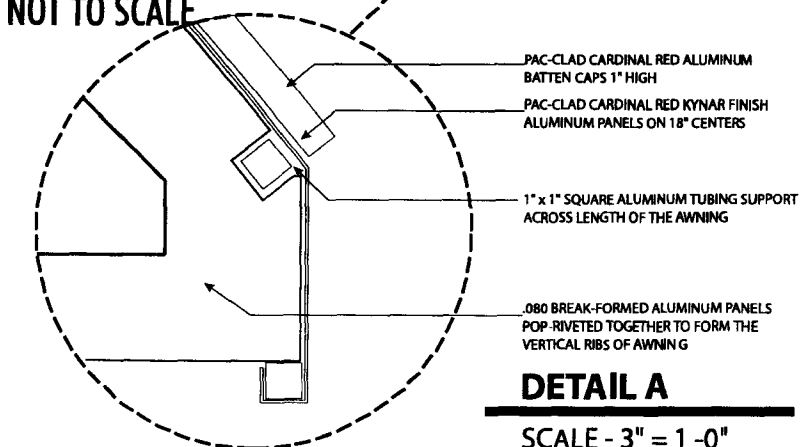

DETAIL A

SCALE - 3" = 1'-0"

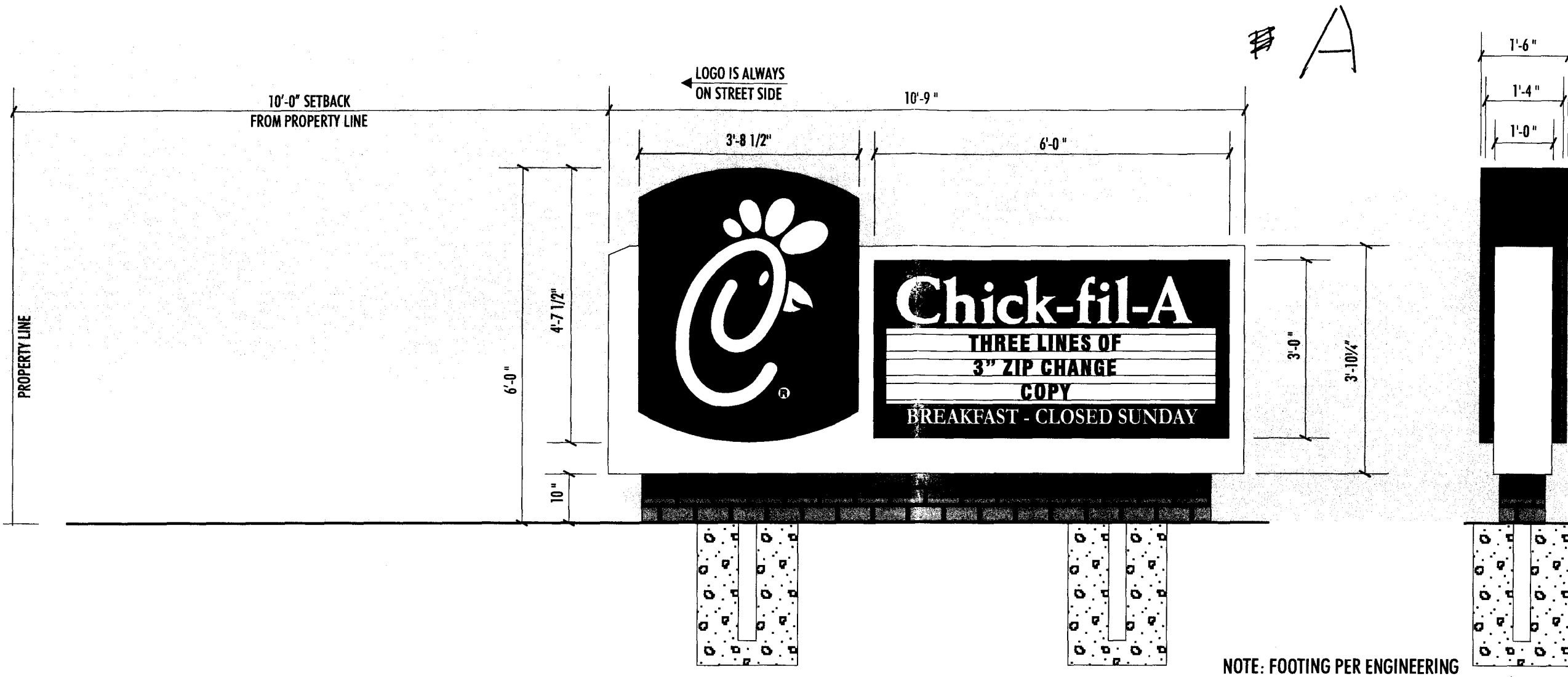

NOTE: FOOTING PER ENGINEERING

M D/F ILLUMINATED MONUMENT SIGN (NORTH ELEVATION SHOWN)
SCALE: 1/2" = 1'-0"

SPECIFICATIONS:

SIGN FRAME:

18" WIDE .050" ALUMINUM LOGO FILLER WITH 1 1/2" RETAINERS
SERVICE THRU ACCESS WHEN FACES ARE REMOVED
DOUBLE ANGLE IRON FRAMEWORK CABINET (1 1/2"x1 1/2") WITH .080" ALUMINUM SKIN
BASE FINISH TO MATCH BUILDING STONEWORK:
4"x8"x16" SPLITFACED CMU #620 "WHEAT" AS MANUFACTURED BY BUEHNER BLOCK
(801)467-5457. BLOCK TO MATCH OTHER RETAIL BUILDINGS AT RIMROCK MARKETPLACE.

FACES:

3/16" #7328 WHITE PLEXIGLAS
FIRST SURFACE APPLIED 3M 53 VINYL GRAPHICS
COPY AND LOGO ROUTED OUT TO SHOW AS WHITE
RECTANGULAR CABINET TO HAVE CLEAR LOCKABLE LEXAN COVERS TO SECURE CHANGEABLE COPY

WIND LOAD:

DESIGNED FOR 30 PSF WIND LOAD

ELECTRICAL:

ALL ELECTRICAL COMPONENTS U.L. LISTED. SIGN TO BEAR U.L. LABEL
COOL WHITE HIGH OUTPUT FLOURESCENT LAMPS ON 12" CENTERS, MOUNTED VERTICALLY
TOTAL CURRENT: 15 AMPS

- SIGNS TO BE "CARDINAL RED" GRIP GARD #053 (FIVE YEAR PAINT WARRANTY)
- .187" PLEX (#7328 WHITE) WITH FIRST SURFACE VINYL (3M RED TRANS. #230-53) COPY & LOGO ROUTED OUT TO SHOW AS WHITE
- ALUMINUM PAINTED WHITE GRIP GARD #RST584

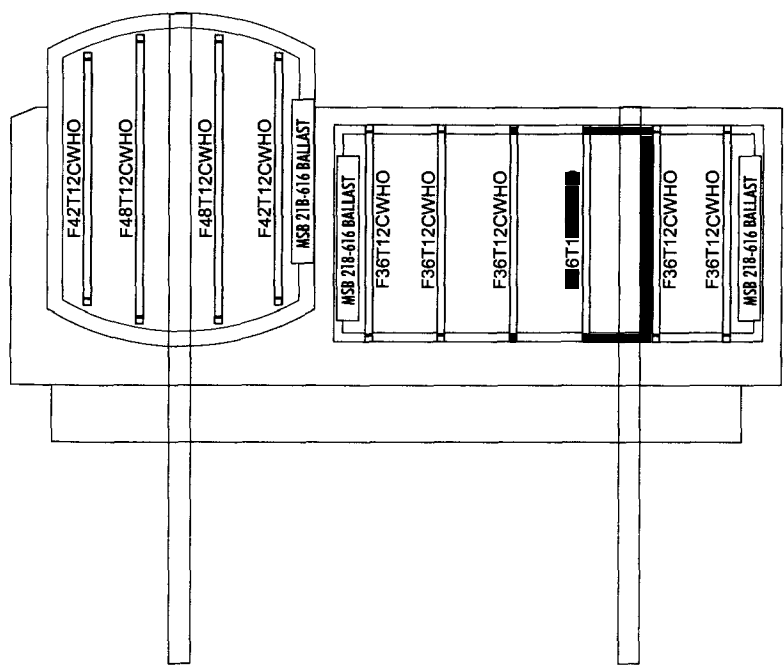

1700 West Anaheim Street
Long Beach, California
90813-1195
phone: 562.495.3808
facsimile: 562.435.1867

www.superiorsigns.com
design@superiorsigns.com

Project:
CHICK-FIL-A #1691

Address:
522 BOGART LANE
GRAND JUNCTION, CO

Account Manager:
GEORGE ADAMS

Designer:
MO

Scale:
AS NOTED

Design No.:
04-08-5168-03

Date:
08-13-04

Reg. No.:

Revisions:

- ▲ M.O. 8/18/04 Per redlined drawings dated 8/16/04
- ▲ M.O. 8/19/04 Add stone base specification to monument sign
- ▲ AR 10/29/04 Edit legend and flag pole height.

Page: 13 Of: 17

This is an original unpublished drawing created by Superior Electrical Advertising. It is submitted for your approval. It is not to be shown to anyone outside of your organization, nor is it to be reproduced, copied or exhibited in any fashion. The changing of colors, sizes, materials or illumination method does not alter the design. Ownership of this design is held by Superior Electrical Advertising, Inc. Authorization to use this design in any fashion must be obtained in writing from Superior Electrical Advertising, Inc.

© SEA 2004
Note: The Colors depicted here are a graphic representation. Actual colors may vary. See color specifications.

- 1 M.O. 8/18/04 Per redlined drawings dated 8/16/04
- 2 M.O. 8/19/04 Add stone base specification to monument sign
- 3 AR 10/29/04 Edit legend and flag pole height.

This is an original unpublished drawing created by Superior Electrical Advertising. It is submitted for your approval. It is not to be shown to anyone outside of your organization, nor is it to be reproduced, copied or exhibited in any fashion. The changing of colors, sizes, materials or illumination method does not alter the design. Ownership of this design is held by Superior Electrical Advertising, Inc. Authorization to use this design in any fashion must be obtained in writing from Superior Electrical Advertising, Inc.

© SEA 2004
Note: The Colors depicted here are a graphic representation. Actual colors may vary. See color specifications.

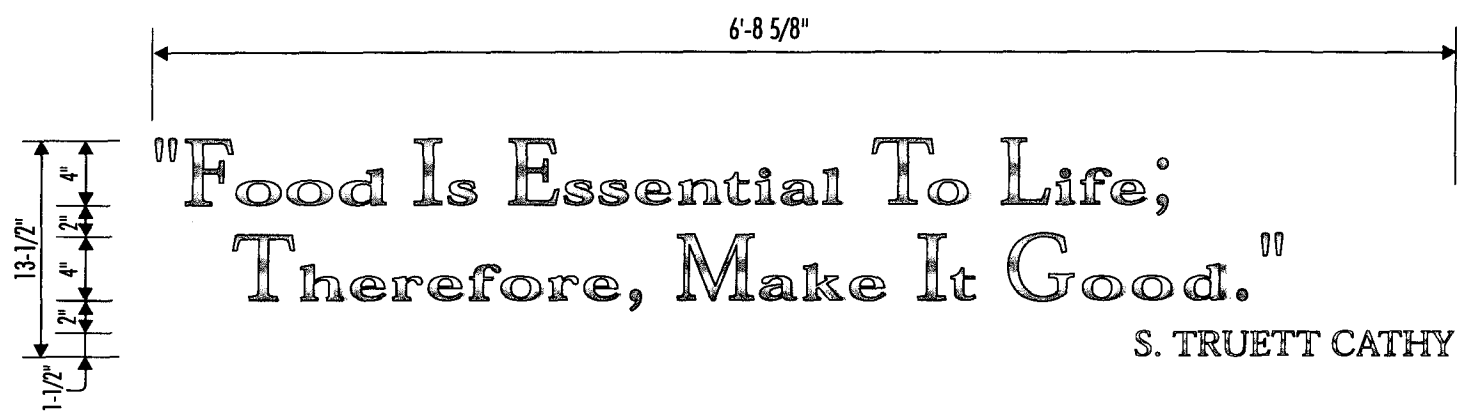

DETAIL - BRUSHED ALUMINUM LAMINATE LETTERS - WALL MOUNTED
SCALE: 1" = 1'-0"

LETTERS ARE TO BE 1/2" THICK 'SINTRA' WITH BRUSHED SILVER FACES, BLACK EDGES AND ARE TO BE FLUSH MOUNTED TO WALL WITH 3M DOUBLE BACK TAPE and GLUE.

NOTE TO VENDORS:

This set of letters comes with a mounting / Spacing pattern, pre applied double back tape and a tube of glue for permanently fixing letters to wall. letters will not stay attached to wall without glue. Double back tape is for holding letters in place until glue dries. Please read and follow instructions on tube of glue. (1 tube provided for both sets to be mounted)

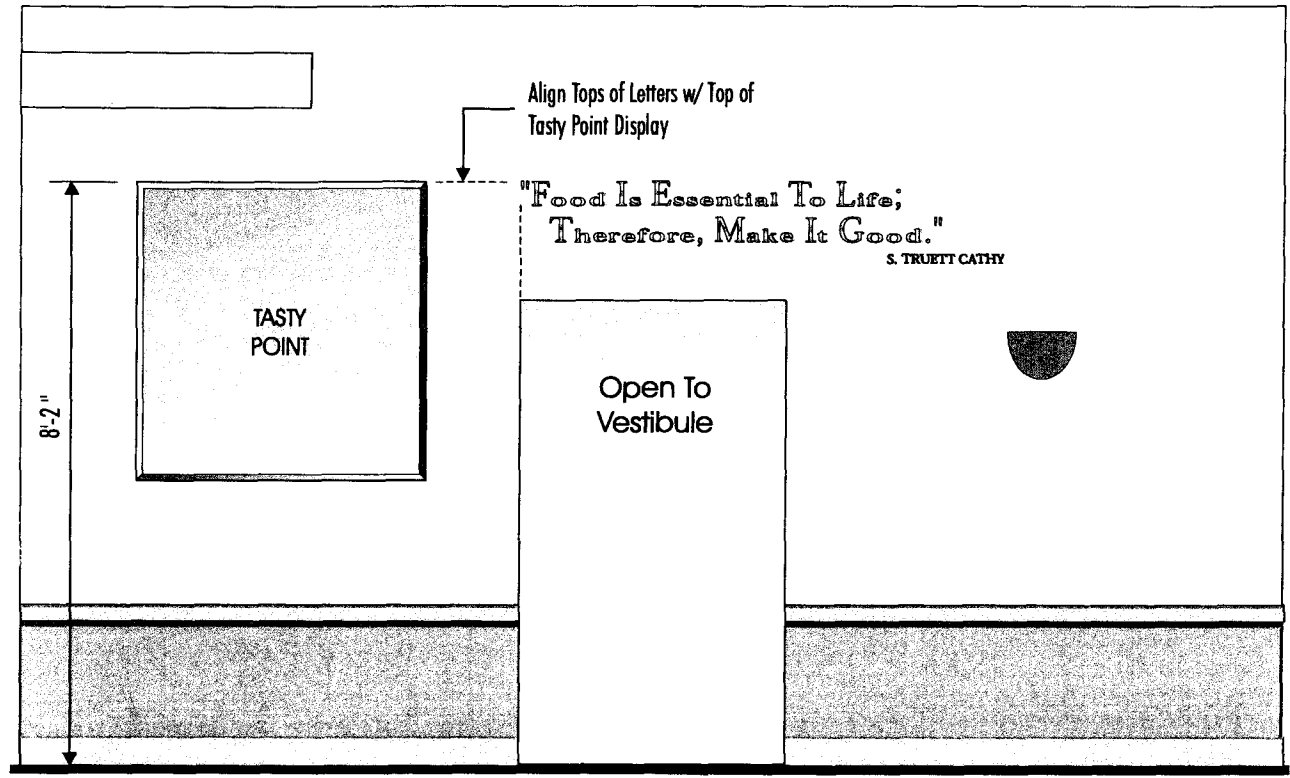

14 ELEVATION
SCALE: 3/8" = 1'-0"



1700 West Anaheim Street
 Long Beach, California
 90813-1195
 phone: 562.495.3808
 facsimile: 562.435.1867

www.superiorsigns.com
 design@superiorsigns.com

Project:
 CHICK-FIL-A #1691

Address:
 522 BOGART LANE
 GRAND JUNCTION, CO

Account Manager:
 GEORGE ADAMS

Designer:
 MO

Scale:
 AS NOTED

Design No.:
 04-08-5168-03

Date:
 08-13-04

Reg. No.:

Revisions:

- 1 M.O. 8/18/04 Per redlined drawings dated 8/16/04
- 2 M.O. 8/19/04 Add stone base specification to monument sign
- 3 AR 10/29/04 Edit legend and flag pole height.

Page: 15 Of: 17

This is an original unpublished drawing created by Superior Electrical Advertising. It is submitted for your approval. It is not to be shown to anyone outside of your organization, nor is it to be reproduced, copied or exhibited in any fashion. The changing of colors, sizes, materials or illumination method does not alter the design. Ownership of this design is held by Superior Electrical Advertising, Inc. Authorization to use this design in any fashion must be obtained in writing from Superior Electrical Advertising, Inc.
 © SEA 2004

Note: The Colors depicted here are a graphic representation. Actual colors may vary. See color specifications.

NOTE TO VENDORS:

This set of letters comes with a mounting / Spacing pattern, pre applied double back tape and a tube of glue for permanently fixing letters to wall. letters will not stay attached to wall without glue. Double back tape is for holding letters in place until glue dries. Please read and follow instructions on tube of glue. (1 tube provided for both sets to be mounted)

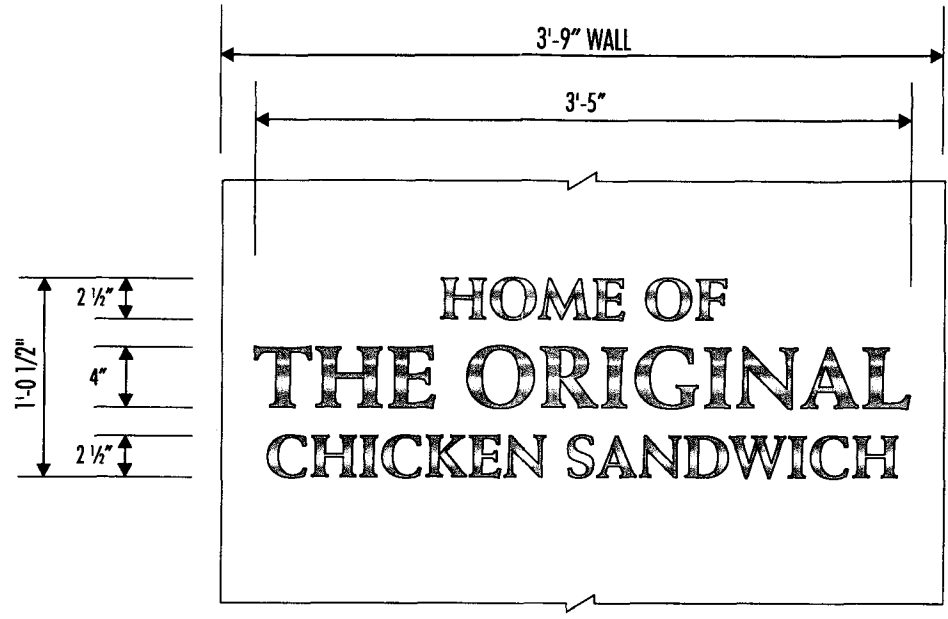

LETTERS ARE TO BE 1/2" THICK 'SINTRA' WITH BRUSHED ALUM. FACES, BLACK EDGES AND ARE TO BE FLUSH MOUNTED TO WALL WITH 3M DOUBLE BACK TAPE and GLUE

DETAIL - BRUSHED ALUMINUM LAMINATE LETTERS - WALL MOUNTED
 SCALE: 1" = 1'-0"

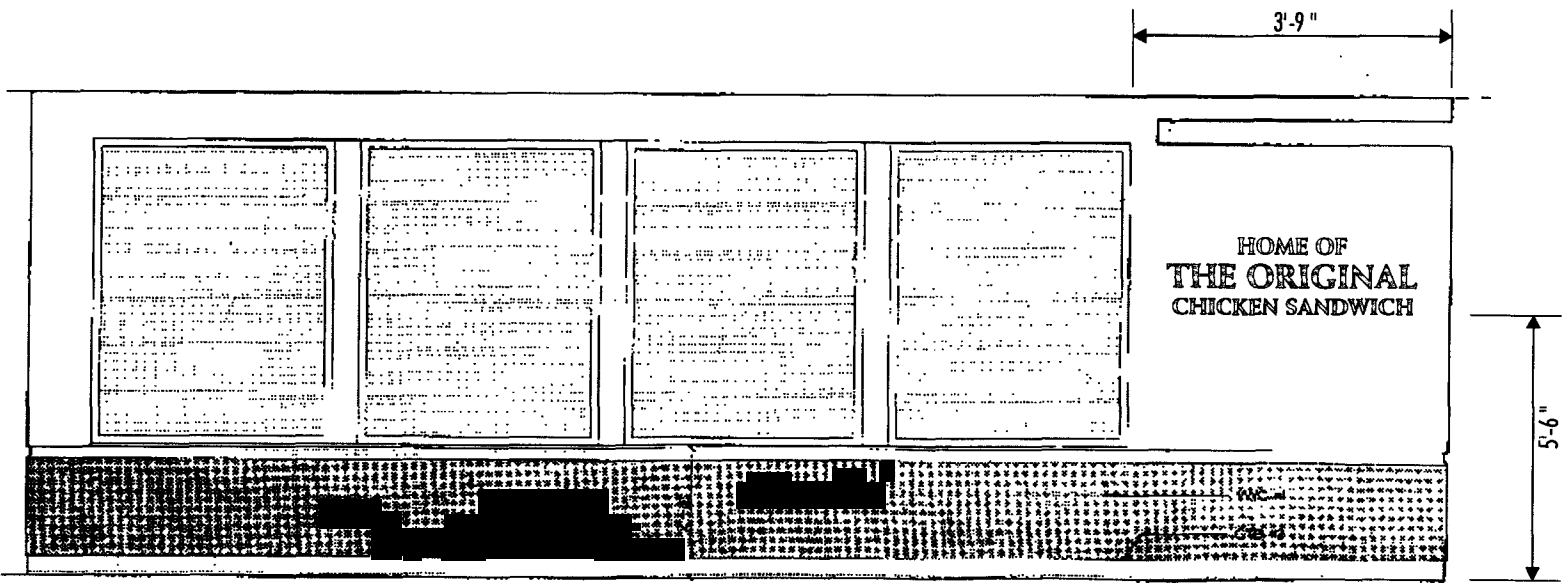

15 ELEVATION - DINING "B"
 SCALE: 1/4" = 1'-0"

1 1/2" STORE HOURS
 1" Monday - Saturday
 1" 6:30 AM - 10:00 PM
 1" CLOSED SUNDAY

P FIRST SURFACE WHITE DOOR WINDOW VINYL QTY: TWO (2) SETS
 SCALE: 3" = 1'-0"

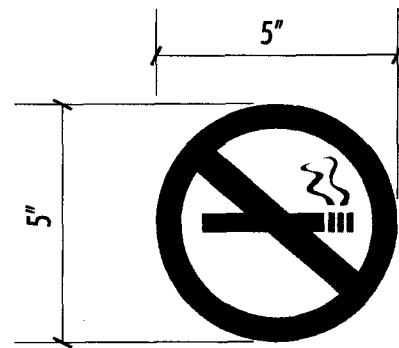

1" SMOKE FREE ENVIRONMENT

1" NO SOLICITING

Q FIRST SURFACE RED DOOR WINDOW VINYL QTY: TWO (2) SETS
 SCALE: 3" = 1'-0"

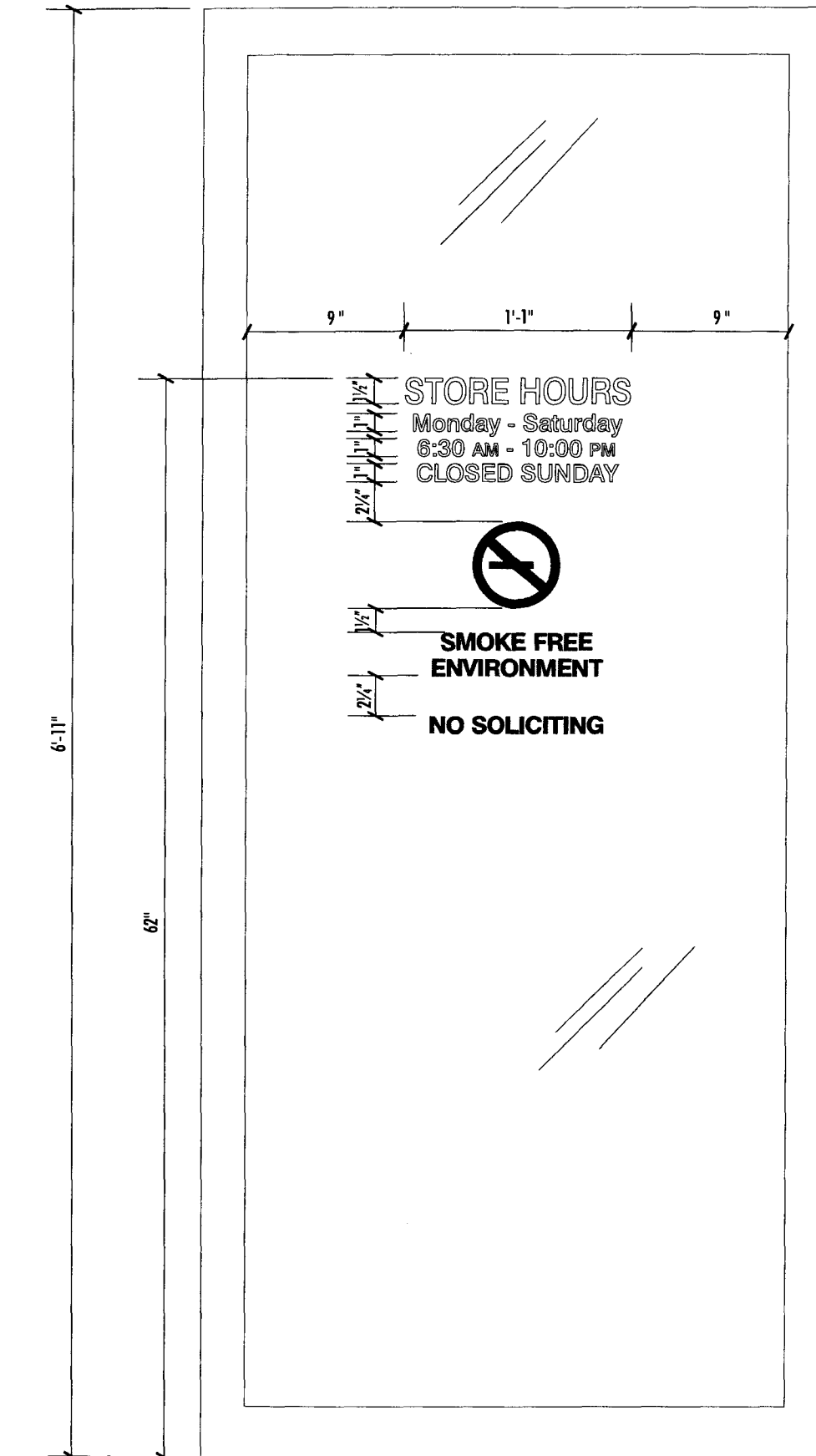

16 DOOR WINDOW VINYL
 SCALE: NTS



1700 West Anaheim Street
 Long Beach, California
 90813-1195
 phone: 562.495.3808
 facsimile: 562.435.1867

www.superiorsigns.com
 design@superiorsigns.com

Project:
 CHICK-FIL-A #1691

Address:
 522 BOGART LANE
 GRAND JUNCTION, CO

Account Manager:
 GEORGE ADAMS

Designer:
 MO

Scale:
 AS NOTED

Design No.:
 04-08-5168-03

Date:
 08-13-04

Reg. No.:

Revisions:

- △ M.O. 8/18/04 Per redlined drawings dated 8/16/04
- △ M.O. 8/19/04 Add stone base specification to monument sign
- △ AR 10/29/04 Edit legend and flag pole height.

Page: 16 Of: 17

This is an original unpublished drawing created by Superior Electrical Advertising. It is submitted for your approval. It is not to be shown to anyone outside of your organization, nor is it to be reproduced, copied or exhibited in any fashion. The changing of colors, sizes, materials or illumination method does not alter the design. Ownership of this design is held by Superior Electrical Advertising, Inc. Authorization to use this design in any fashion must be obtained in writing from Superior Electrical Advertising, Inc.

© SEA 2004

Note: The Colors depicted here are a graphic representation. Actual colors may vary. See color specifications.

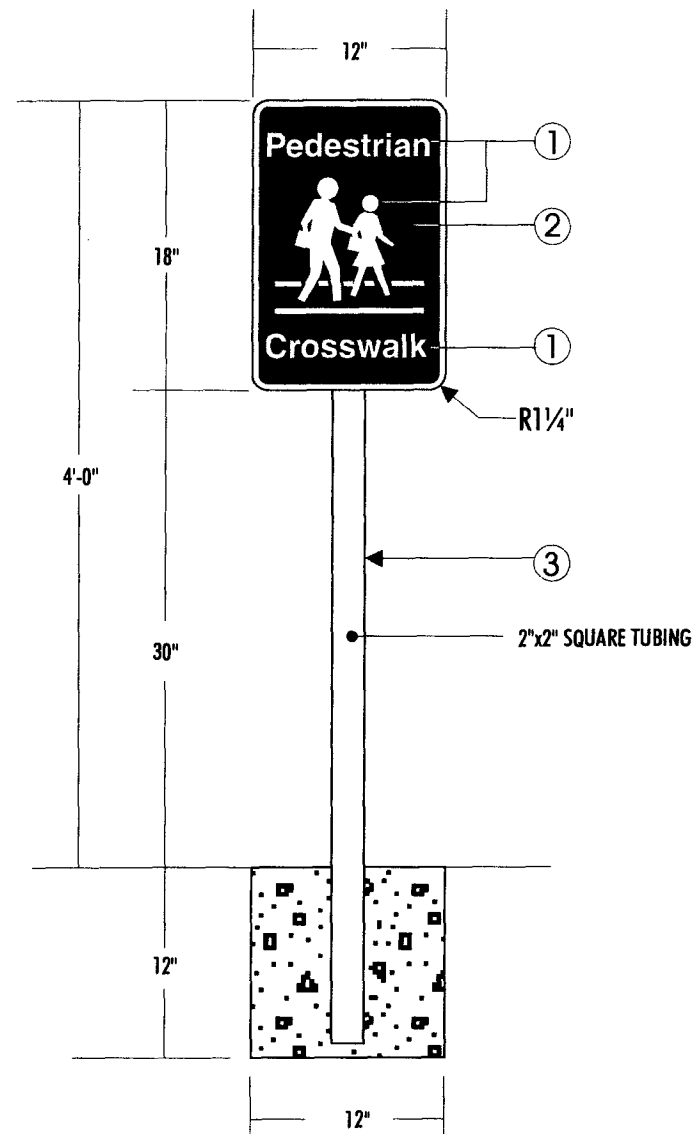

R PEDESTRIAN CROSSWALK SIGN QTY: ONE (1)
SCALE: 1" = 1'-0"

NOTES:
SIGN IS TO BE S/F .080 NON-ILLUMINATED
GRAPHICS APPLIED FIRST SURFACE
LETTER STYLE HELVETICA MEDIUM

COLOR PLACEMENT:

1. WHITE "REFLECTIVE"
2. RED "REFLECTIVE"
3. PAINT: AKZO-NOBEL "GRIP GARD" ACRYLIC POLYURETHANE WHITE #RST584

NOTE: VERIFY COLORS WITH LOCAL MUNICIPALITY

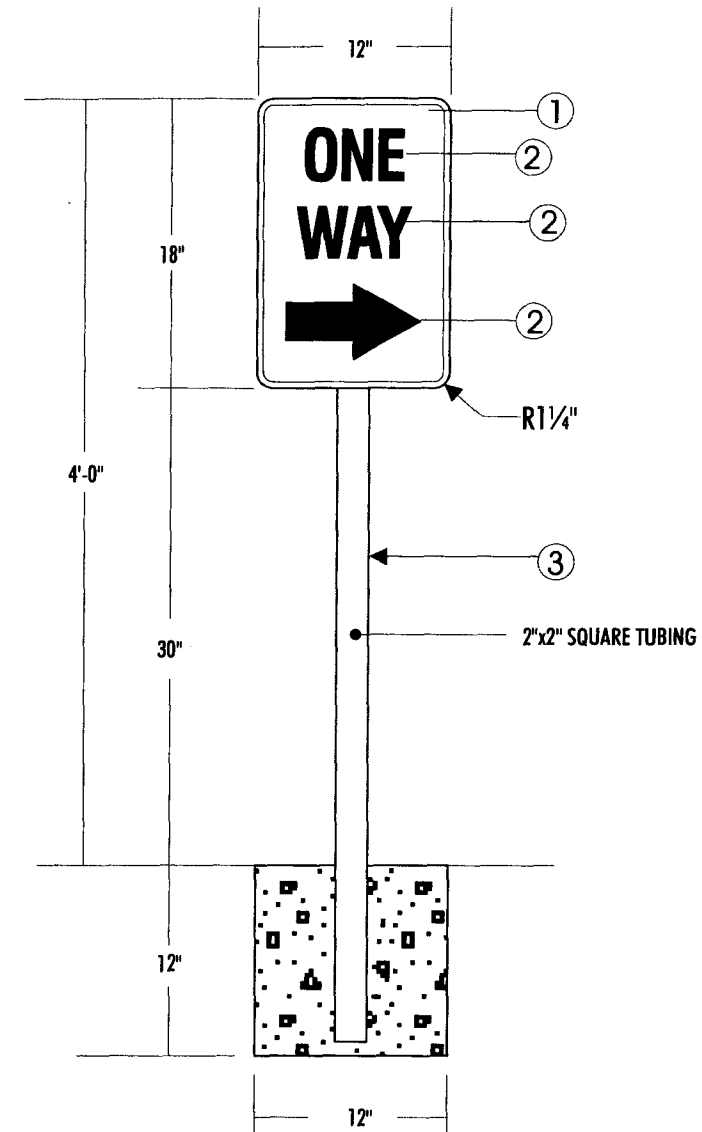

S ONE WAY SIGN QTY: TWO (2)
SCALE: 1" = 1'-0"

NOTES:
SIGN IS TO BE S/F .080 NON-ILLUMINATED
GRAPHICS APPLIED FIRST SURFACE
LETTER STYLE HELVETICA MEDIUM

COLOR PLACEMENT:

1. WHITE
2. BLACK
3. PAINT: AKZO-NOBEL "GRIP GARD" ACRYLIC POLYURETHANE WHITE #RST584

NOTE: VERIFY COLORS WITH LOCAL MUNICIPALITY



superior
electrical advertising

1700 West Anaheim Street
Long Beach, California
90813-1195
phone: 562.495.3808
facsimile: 562.435.1867

www.superiorsigns.com
design@superiorsigns.com

Project:
CHICK-FIL-A #1691

Address:
522 BOGART LANE
GRAND JUNCTION, CO

Account Manager:
GEORGE ADAMS

Designer:
MO

Scale:
AS NOTED

Design No.:
04-08-5168-03

Date:
08-13-04

Reg. No.:

Revisions:

- 1 M.O. 8/18/04 Per redlined drawings dated 8/16/04
- 2 M.O. 8/19/04 Add stone base specification to monument sign
- 3 AR 10/29/04 Edit legend and flag pole height.

Page: 17 Of: 17

This is an original unpublished drawing created by Superior Electrical Advertising. It is submitted for your approval. It is not to be shown to anyone outside of your organization, nor is it to be reproduced, copied or exhibited in any fashion. The changing of colors, sizes, materials or illumination method does not alter the design. Ownership of this design is held by Superior Electrical Advertising, Inc. Authorization to use this design in any fashion must be obtained in writing from Superior Electrical Advertising, Inc.

© SEA 2004

Note: The Colors depicted here are a graphic representation. Actual colors may vary. See color specifications.



1700 West Anaheim Street
 Long Beach, California
 90813-1195
 phone: 562.495.3808
 facsimile: 562.435.1867

www.superiorsigns.com
 design@superiorsigns.com

Project:
 CHICK-FIL-A #1691

Address:
 522 BOGART LANE
 GRAND JUNCTION, CO

Account Manager:
 GEORGE ADAMS

Designer:
 MO

Scale:
 AS NOTED

Design No.:
 04-08-5168-03

Date:
 08-13-04

Reg. No.:

Revisions:

- 1 M.O. 8/18/04 Per redlined drawings dated 8/16/04
- 2 M.O. 8/19/04 Add stone base specification to monument sign
- 3 AR 10/29/04 Edit legend and flag pole height.

Page: 2 Of: 17

This is an original unpublished drawing created by Superior Electrical Advertising. It is submitted for your approval. It is not to be shown to anyone outside of your organization, nor is it to be reproduced, copied or exhibited in any fashion. The changing of colors, sizes, materials or illumination method does not alter the design. Ownership of this design is held by Superior Electrical Advertising, Inc. Authorization to use this design in any fashion must be obtained in writing from Superior Electrical Advertising, Inc.

© SEA 2004

Note: The Colors depicted here are a graphic representation. Actual colors may vary. See color specifications.

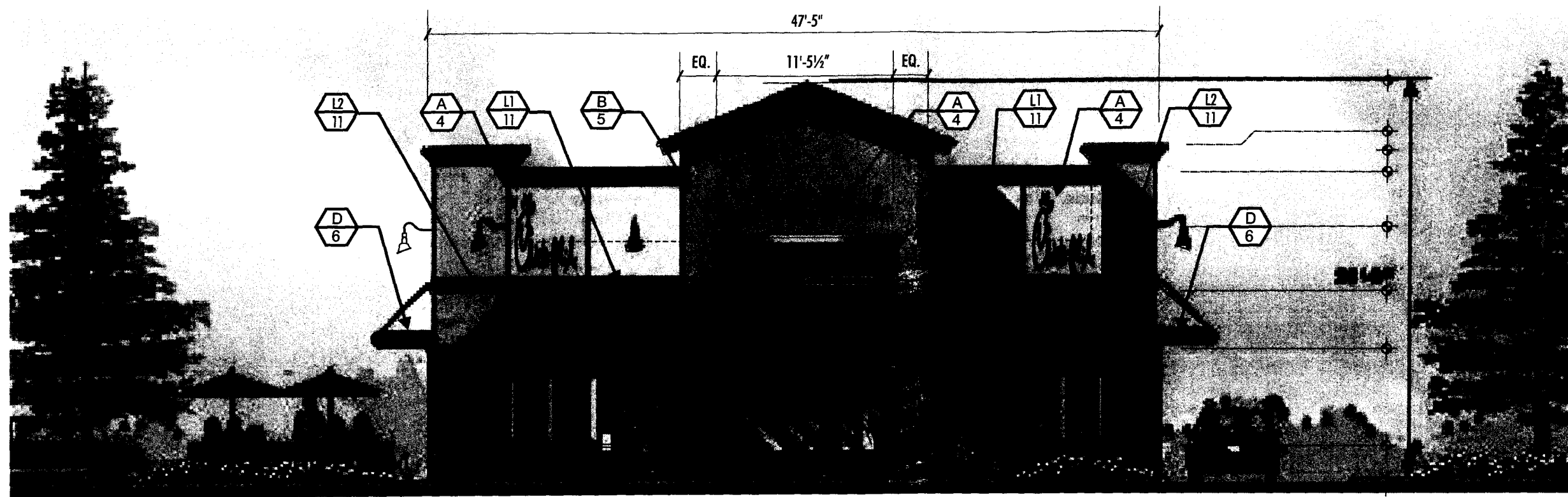

2 FRONT ELEVATION (NORTH)
 SCALE: 1/8" = 1'-0"

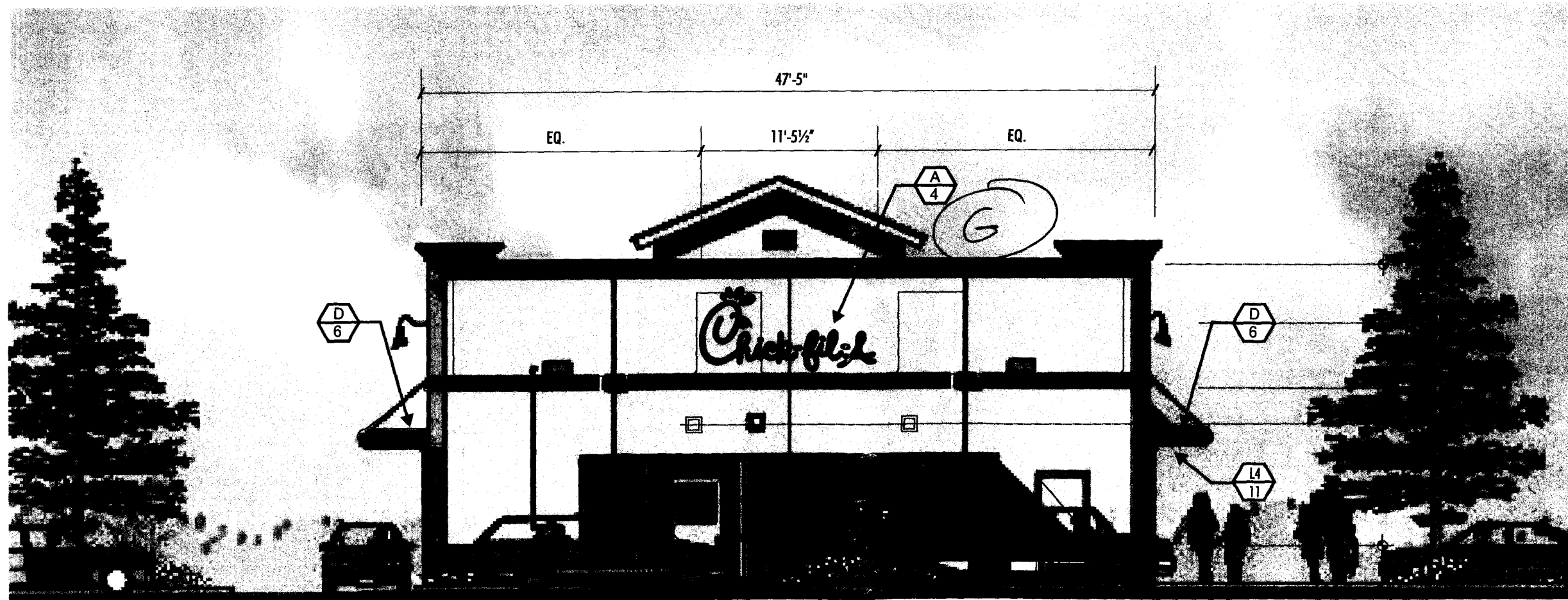

3 REAR ELEVATION (SOUTH)
 SCALE: 1/8" = 1'-0"



1400 West Anderson Street
 Long Beach, California 90813 1156
 Phone: 562-495-3808
 Fax: 562-495-3808
 www.sunshinetrail.com
 info@sunshinetrail.com
 PO Box 1714, Long Beach, CA 90801

Account Manager
 Designer
 No. 00
 Scale: AS SHOWN
 Design No. CA-08-5182-04
 Date: 08-13-04
 Proj. No. 08-13-04

Project:
 Site: 08-5182-04
 Date: 08-13-04
 Proj. No. 08-13-04

Page 7 of 17

12/1/04
 for this parcel -
 papertrail -
 Revenue

Exempt - under 3 \$ -

FOR PERMITTING
 CHICK FALL-A
 GRAND JUNCTION

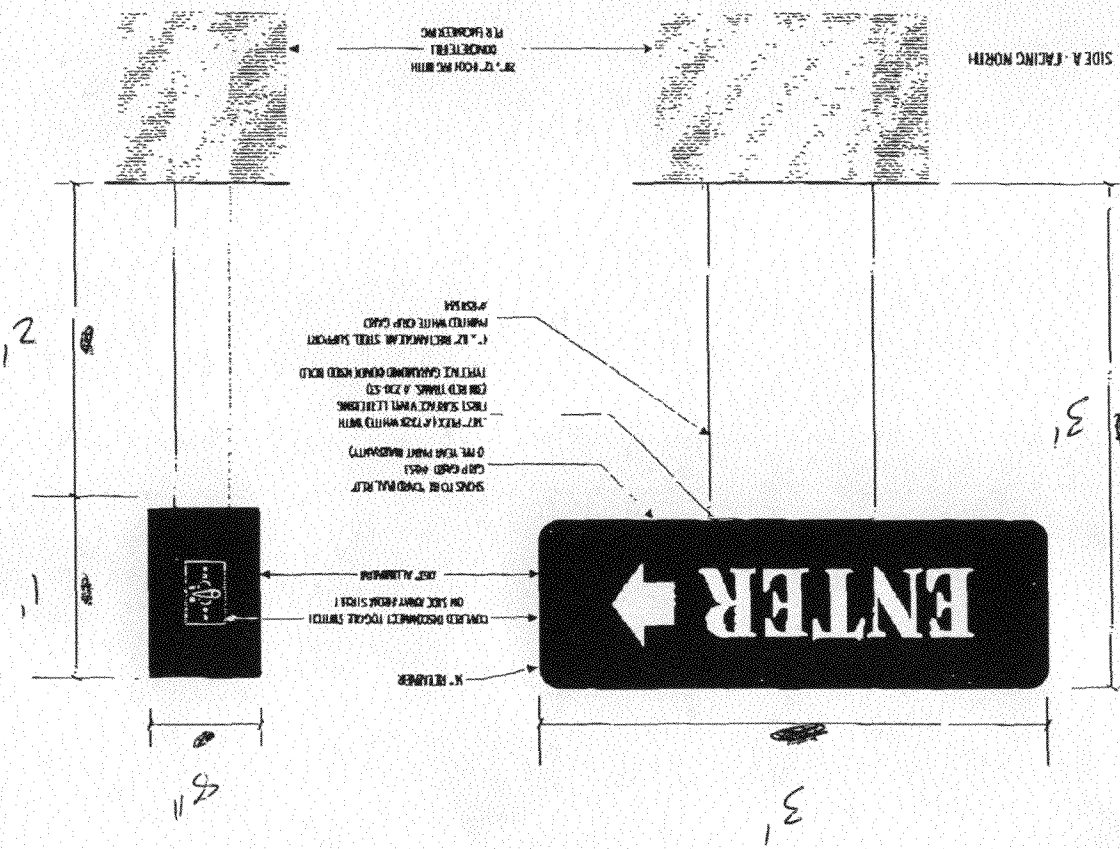
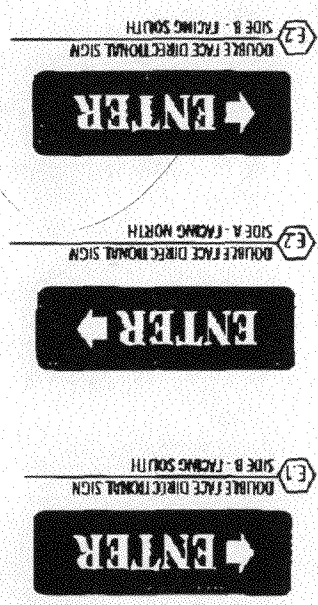

E1 CUSTOM FABRICATED ALUMINUM DOUBLE FACE DIRECTIONAL SIGN
 SCALE: 1/8" = 1'-0"
 QTY: THREE (3)
 AREA: 3 SQ. FT.
 MAKE ONE (1) TYPE C1 THREE (3) LETTER / LETTER
 MAKE TWO (2) TYPE C2 THREE (3) LETTER / LETTER

SIGNS TO BE FABRICATED OF ALUMINUM AND DOUBLE ALUMINUM
 ALUMINUM VISIBLE FASTENERS, BRUSHED ALUMINUM PAINTED WITH
 ACRYLIC PAPER PRINTING FINISH (BLACK WHITE, GRAY, GOLD)
 SIGNS TO BE FABRICATED WITH BRUSHED ALUMINUM
 SIGNS TO BE FABRICATED WITH BRUSHED ALUMINUM
 SIGNS TO BE FABRICATED WITH BRUSHED ALUMINUM
 SIGNS TO BE FABRICATED WITH BRUSHED ALUMINUM

Note - 4th directional (pg 7)
 deleted - will not be
 done -