



SIGN PERMIT

2

Community Development Department
250 North 5th Street
Grand Junction, CO 81501
(970) 244-1430

Permit No. _____
Date Submitted 8/2/04
FEE \$ 25.00
Tax Schedule 2945-114-00-048
Zone B-1

A

BUSINESS NAME Bank of the West
STREET ADDRESS 1211 N. 7th St
PROPERTY OWNER Community First
OWNER ADDRESS _____

CONTRACTOR Platinum Sign
LICENSE NO. _____
ADDRESS 2916 E-70B
TELEPHONE NO. 248-9677 Mike

- 1. FLUSH WALL 2 Square Feet per Linear Foot of Building Facade
- Face Change Only (2,3 & 4):
- 2. ROOF 2 Square Feet per Linear Foot of Building Facade
- 3. FREE-STANDING 2 Traffic Lanes - 0.75 Square Feet x Street Frontage
4 or more Traffic Lanes - 1.5 Square Feet x Street Frontage
- 4. PROJECTING 0.5 Square Feet per each Linear Foot of Building Facade

Existing Externally or Internally Illuminated - No Change in Electrical Service Non-Illuminated

(1 - 4) Area of Proposed Sign 69.79 Square Feet
(1,2,4) Building Facade 105 Linear Feet
(1 - 4) Street Frontage 130 Linear Feet
(2,3,4) Height to Top of Sign _____ Feet Clearance to Grade _____ Feet

Existing Signage/Type:	
<u>None</u>	Sq. Ft.
	Sq. Ft.
	Sq. Ft.
Total Existing:	Sq. Ft.

● FOR OFFICE USE ONLY ●	
Signage Allowed on Parcel:	<u>Glenwood</u>
Building	<u>210</u> Sq. Ft.
Free-Standing	<u>97.5</u> Sq. Ft.
Total Allowed:	<u>210</u> Sq. Ft.

COMMENTS: Existing Signs will be taken down

NOTE: No sign may exceed 300 square feet. A separate sign permit is required for each sign. Attach a sketch of proposed and existing signage including types, dimensions, lettering, abutting streets, alleys, easements, property lines, and locations. Roof signs shall be manufactured such that no guy wires, braces or supports shall be visible.

[Signature] 7-30-04 C. Gay Hall 8/3/04
Applicant's Signature Date Community Development Approval Date

(White: Community Development) (Canary: Applicant) (Pink: Code Enforcement)



SIGN PERMIT

Community Development Department
250 North 5th Street
Grand Junction, CO 81501
(970) 244-1430

Permit No. _____
Date Submitted 8/2/04
FEE \$ 5.00
Tax Schedule 2945-114-00-048
Zone B-1

(B)

BUSINESS NAME Bank of the West
~~Platinum Sign~~
STREET ADDRESS 1211 N 7th
PROPERTY OWNER Community First
OWNER ADDRESS _____
CONTRACTOR Platinum Sign
LICENSE NO. _____
ADDRESS 2916 I-70B
TELEPHONE NO. 248-9677 Mike

- 1. FLUSH WALL 2 Square Feet per Linear Foot of Building Facade
- Face Change Only (2,3 & 4):
- 2. ROOF 2 Square Feet per Linear Foot of Building Facade
- 3. FREE-STANDING 2 Traffic Lanes - 0.75 Square Feet x Street Frontage
4 or more Traffic Lanes - 1.5 Square Feet x Street Frontage
- 4. PROJECTING 0.5 Square Feet per each Linear Foot of Building Facade

Existing Externally or Internally Illuminated - No Change in Electrical Service Non-Illuminated

(1 - 4) Area of Proposed Sign 69.79 Square Feet
(1,2,4) Building Facade 90 Linear Feet
(1 - 4) Street Frontage 230 Linear Feet
(2,3,4) Height to Top of Sign _____ Feet Clearance to Grade _____ Feet

Existing Signage/Type:	
<input checked="" type="checkbox"/> None on this frontage 69.79	Sq. Ft.
	Sq. Ft.
	Sq. Ft.
Total Existing:	Sq. Ft.

● FOR OFFICE USE ONLY ●		
Signage Allowed on Parcel:	<u>7th St</u>	
Building	<u>180</u>	Sq. Ft.
Free-Standing	<u>345</u>	Sq. Ft.
Total Allowed:	<u>345</u>	Sq. Ft.

COMMENTS: _____

NOTE: No sign may exceed 300 square feet. A separate sign permit is required for each sign. Attach a sketch of proposed and existing signage including types, dimensions, lettering, abutting streets, alleys, easements, property lines, and locations. Roof signs shall be manufactured such that no guy wires, braces or supports shall be visible.

[Signature] 7-30-04 C. J. Hall 8/3/04
Applicant's Signature Date Community Development Approval Date

(White: Community Development)

(Canary: Applicant)

(Pink: Code Enforcement)



SIGN PERMIT

Community Development Department
250 North 5th Street
Grand Junction, CO 81501
(970) 244-1430

Permit No. _____
Date Submitted 8/2/04
FEE \$ 5.00
Tax Schedule 2945-114-00-048
Zone B-1

(C)

BUSINESS NAME Bank of the West
STREET ADDRESS 1211 N. 7th
PROPERTY OWNER Community First
OWNER ADDRESS _____

CONTRACTOR Platinum Sign
LICENSE NO. _____
ADDRESS 2916 I-70 B
TELEPHONE NO. 248-9677 Mike

- 1. FLUSH WALL 2 Square Feet per Linear Foot of Building Facade
- Face Change Only (2,3 & 4):
- 2. ROOF 2 Square Feet per Linear Foot of Building Facade
- 3. FREE-STANDING 2 Traffic Lanes - 0.75 Square Feet x Street Frontage
4 or more Traffic Lanes - 1.5 Square Feet x Street Frontage
- 4. PROJECTING 0.5 Square Feet per each Linear Foot of Building Facade

Existing Externally or Internally Illuminated - No Change in Electrical Service Non-Illuminated

(1 - 4) Area of Proposed Sign 69.79 Square Feet
(1,2,4) Building Facade 90 Linear Feet
(1 - 4) Street Frontage 230 Linear Feet
(2,3,4) Height to Top of Sign _____ Feet Clearance to Grade _____ Feet

Existing Signage/Type:	
<u>(B) FW</u>	<u>69.79</u> Sq. Ft.
	Sq. Ft.
	Sq. Ft.
Total Existing:	<u>69.79</u> Sq. Ft.

● FOR OFFICE USE ONLY ●	
Signage Allowed on Parcel:	<u>7th St</u>
Building	<u>180</u> Sq. Ft.
Free-Standing	<u>345</u> Sq. Ft.
Total Allowed:	<u>345</u> Sq. Ft.

COMMENTS: _____

NOTE: No sign may exceed 300 square feet. A separate sign permit is required for each sign. Attach a sketch of proposed and existing signage including types, dimensions, lettering, abutting streets, alleys, easements, property lines, and locations. Roof signs shall be manufactured such that no guy wires, braces or supports shall be visible.

[Signature] 7-30-04 C. Faye Hall 8/3/04
Applicant's Signature Date Community Development Approval Date

(White: Community Development) (Canary: Applicant) (Pink: Code Enforcement)



SIGN PERMIT

Community Development Department
250 North 5th Street
Grand Junction, CO 81501
(970) 244-1430

Permit No. _____
Date Submitted 8/2/04
FEE \$ 5.00
Tax Schedule 2945-114-00-048
Zone B-1



BUSINESS NAME Bank of the West
STREET ADDRESS 1211 N. 7th
PROPERTY OWNER Community First
OWNER ADDRESS _____

CONTRACTOR Platinum Sign
LICENSE NO. _____
ADDRESS 2916 I-70 B
TELEPHONE NO. 248-9677 Mike

- 1. FLUSH WALL 2 Square Feet per Linear Foot of Building Facade
- Face Change Only (2,3 & 4):**
- 2. ROOF 2 Square Feet per Linear Foot of Building Facade
- 3. FREE-STANDING 2 Traffic Lanes - 0.75 Square Feet x Street Frontage
4 or more Traffic Lanes - 1.5 Square Feet x Street Frontage
- 4. PROJECTING 0.5 Square Feet per each Linear Foot of Building Facade

Existing Externally or Internally Illuminated - No Change in Electrical Service Non-Illuminated

(1 - 4) Area of Proposed Sign 6.19 Square Feet
(1,2,4) Building Facade 90 Linear Feet
(1 - 4) Street Frontage 230 Linear Feet
(2,3,4) Height to Top of Sign _____ Feet Clearance to Grade _____ Feet

Existing Signage/Type:	
<u>(B) (C)</u>	<u>139.58</u> Sq. Ft.
	Sq. Ft.
	Sq. Ft.
Total Existing:	<u>139.58</u> Sq. Ft.

● FOR OFFICE USE ONLY ●	
Signage Allowed on Parcel:	<u>1th St.</u>
Building	<u>180</u> Sq. Ft.
Free-Standing	<u>345</u> Sq. Ft.
Total Allowed:	<u>345</u> Sq. Ft.

COMMENTS: _____

NOTE: No sign may exceed 300 square feet. A separate sign permit is required for each sign. Attach a sketch of proposed and existing signage including types, dimensions, lettering, abutting streets, alleys, easements, property lines, and locations. Roof signs shall be manufactured such that no guy wires, braces or supports shall be visible.

Applicant's Signature _____ Date _____ Community Development Approval C Faye Hall Date 8/3/04

(White: Community Development) (Canary: Applicant) (Pink: Code Enforcement)

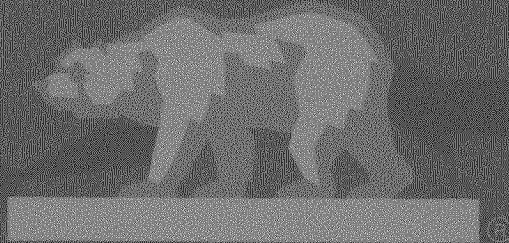

BANK OF THE WEST

1211 N. 7th Street
Grand Junction, CO
Location # CFCO23

Revised: 08/04/04

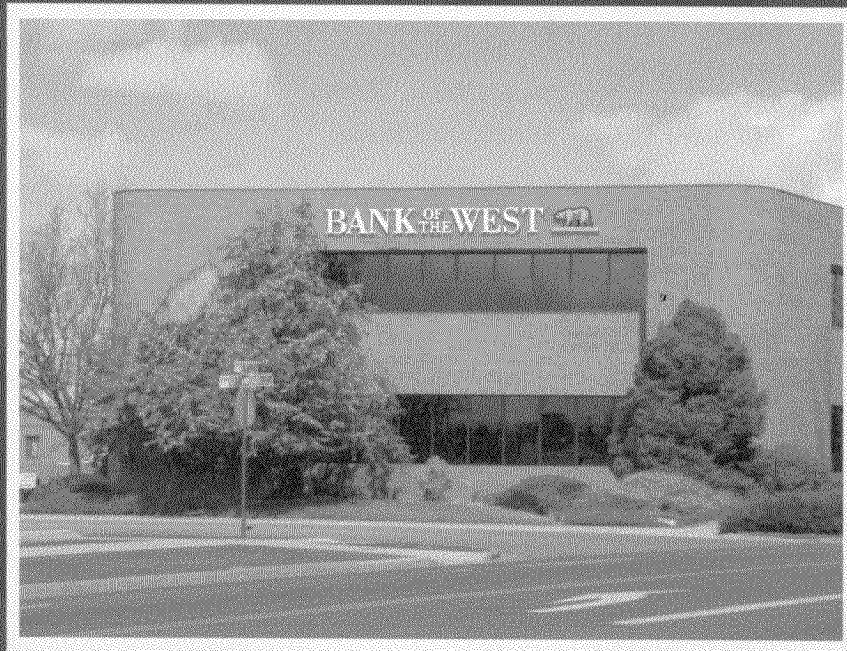

prepared by

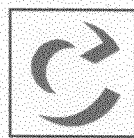

**Chandler
Signs**

BANK OF THE WEST



Perspective Photos



1211 N. 7th Street
Grand Junction, CO
Location # CFCO23

Revised: 08/04/04



BANK OF THE WEST



New Signage Program

Photo Number CFCO23-A

Type S/F SIGN

Height 4'-0"

Width 12'-0"

Depth _____

Overall above grade _____

- | | |
|---|--|
| <input type="checkbox"/> Pylon/Monument | <input checked="" type="checkbox"/> Wall Mount |
| <input type="checkbox"/> Directional | <input type="checkbox"/> Vinyl |
| <input type="checkbox"/> Channel letters | <input type="checkbox"/> Other |
| <input checked="" type="checkbox"/> Single Face | <input type="checkbox"/> Double Face |
| <input checked="" type="checkbox"/> Illuminated | <input type="checkbox"/> Non-Illuminated |

Comments _____



New Signage MFR & INSTALL

(1) SET 30" CHANNEL LETTERS

Comments _____



BANK OF THE WEST



New Signage Program

Photo Number CFCO23-B

Type S/F SIGN

Height 4'-0"

Width 12'-0"

Depth _____

Overall above grade _____

- | | |
|---|--|
| <input type="checkbox"/> Pylon/Monument | <input checked="" type="checkbox"/> Wall Mount |
| <input type="checkbox"/> Directional | <input type="checkbox"/> Vinyl |
| <input type="checkbox"/> Channel letters | <input type="checkbox"/> Other |
| <input checked="" type="checkbox"/> Single Face | <input type="checkbox"/> Double Face |
| <input checked="" type="checkbox"/> Illuminated | <input type="checkbox"/> Non-Illuminated |

Comments _____



New Signage MFR & INSTALL

(1) SET 30" CHANNEL LETTERS

Comments _____



█ N. 7th Street
█ Junction, CO
█ on # CFCO23



BANK OF THE WEST



New Signage Program

Photo Number CFCO23-C

Type NO EXISTING SIGNAGE

Height _____

Width _____

Depth _____

Overall above grade _____

- | | |
|--|--|
| <input type="checkbox"/> Pylon/Monument | <input type="checkbox"/> Wall Mount |
| <input type="checkbox"/> Directional | <input type="checkbox"/> Vinyl |
| <input type="checkbox"/> Channel letters | <input type="checkbox"/> Other |
| <input type="checkbox"/> Single Face | <input type="checkbox"/> Double Face |
| <input type="checkbox"/> Illuminated | <input type="checkbox"/> Non-Illuminated |

Comments _____



New Signage MFR & INSTALL

(1) SET 30" CHANNEL LETTERS

Comments _____





27'-11"



CHANNEL LETTERS & LOGO LAYOUT

1/4" = 1'-0"

(3) SETS REQUIRED - MFR & INSTALL

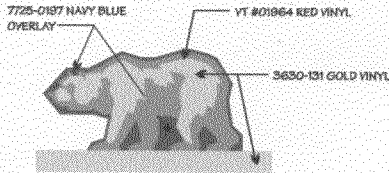

LOGO DETAIL

NOT TO SCALE

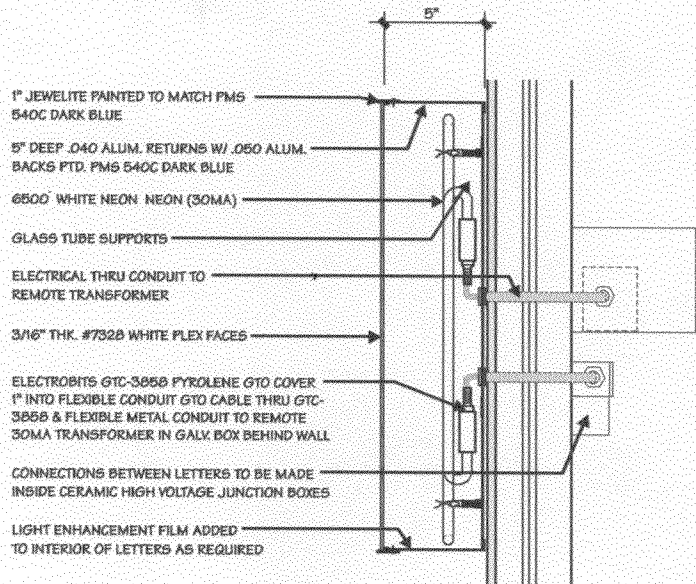

SECTION DETAIL

NOT TO SCALE

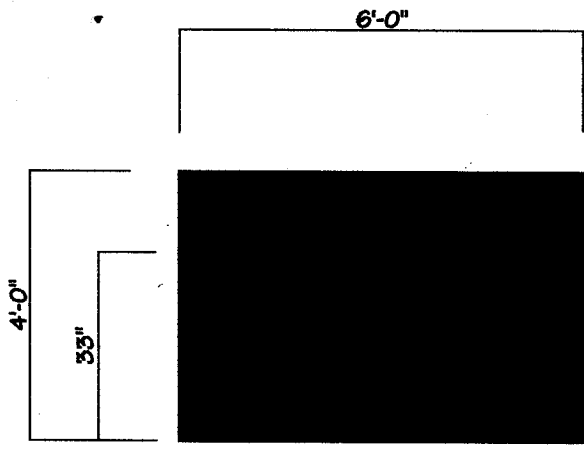

AWNING RECOVER DETAIL

$3/8" = 1'-0"$

RECOVER EXISTING AWNING FRAME W/
FLEXIBLE AWNING MATERIAL TO MATCH PM6 540C DARK BLUE -

END VIEW

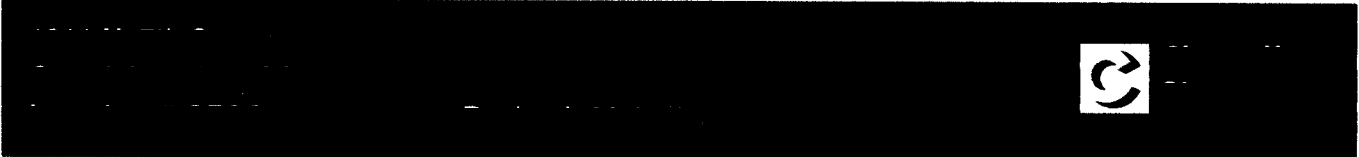

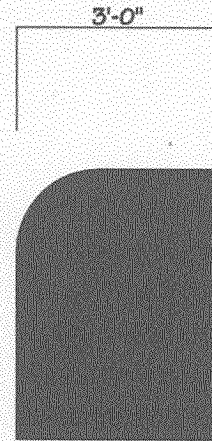
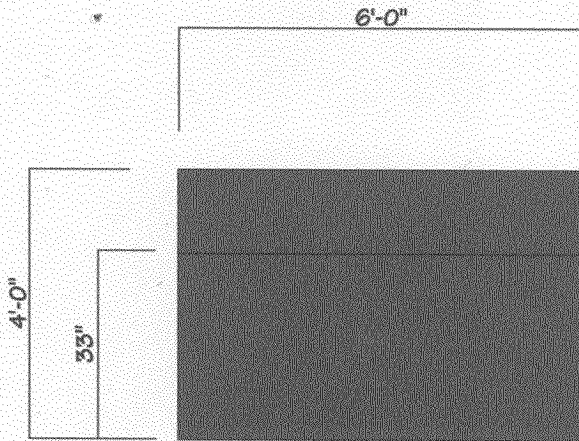

AWNING RECOVER DETAIL

3/8" = 1'-0"

RECOVER EXISTING AWNING FRAME W/
FLEXIBLE AWNING MATERIAL TO MATCH PMS 540C DARK BLUE -

END VIEW





Photo Number CFCO23-E

Type ATM HEADER

Height 17" +/- / 22"

Width 52" +/- / 12 1/2"

Depth _____

Overall above grade _____

- | | |
|---|--|
| <input type="checkbox"/> Pylon/Monument | <input checked="" type="checkbox"/> Wall Mount |
| <input type="checkbox"/> Directional | <input type="checkbox"/> Vinyl |
| <input type="checkbox"/> Channel letters | <input checked="" type="checkbox"/> Other |
| <input type="checkbox"/> Single Face | <input type="checkbox"/> Double Face |
| <input checked="" type="checkbox"/> Illuminated | <input type="checkbox"/> Non-Illuminated |

Comments _____



New Signage MFR & INSTALL

(1) LEXAN

REPLACEMENT FACES

& (1) ALUMINUM

OVERLAY PANEL

Comments _____

1211 N. 7th Street
Grand Junction, CO
Location # CFCO23

Revised: 08/04/04

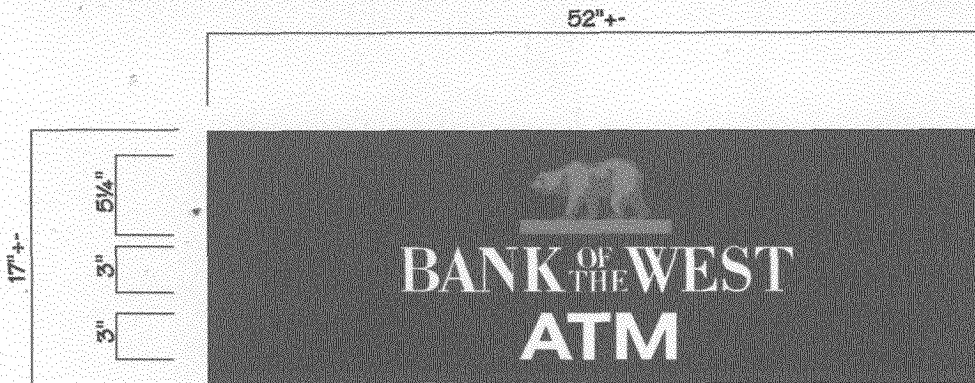

REPLACEMENT FACE DETAIL

1" = 1'-0"

MFR & INSTALL (1) LEXAN REPLACEMENT FACE -

- 732B WHITE LEXAN FACE W/ FIRST SURFACE VINYL GRAPHICS:
- 7725-0197 NAVY BLUE VINYL BACKGROUND OVERLAY -
- LOGO - VT#01964 RED VINYL & #3630-131 GOLD VINYL -
- WHITE SHO-THRU COPY -
- REPAINT EXISTING D/F CABINET TO MATCH PMS 540C DARK BLUE -

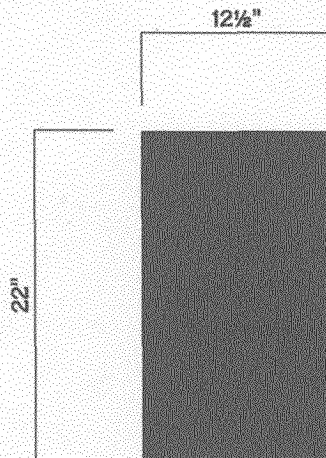

OVERLAY FACE DETAIL

1" = 1'-0"

MFR & INSTALL (1) OVERLAY PANEL -

FLAT ALUMINUM OVERLAY PANEL / PAINT PMS 540C DARK BLUE -



BANK OF THE WEST



New Signage Program

Photo Number CFCO23-F

Type S/F DIRECTIONAL

Height 18"

Width 12"

Depth _____

Overall above grade _____

- | | |
|---|---|
| <input type="checkbox"/> Pylon/Monument | <input type="checkbox"/> Wall Mount |
| <input checked="" type="checkbox"/> Directional | <input type="checkbox"/> Vinyl |
| <input type="checkbox"/> Channel letters | <input type="checkbox"/> Other |
| <input checked="" type="checkbox"/> Single Face | <input type="checkbox"/> Double Face |
| <input type="checkbox"/> Illuminated | <input checked="" type="checkbox"/> Non-Illuminated |

Comments _____



New Signage MFR & INSTALL

(1) S/F DIRECTIONAL

Comments LOGOS/NAMES NOT ALLOWED ON 3 SQ.FT. DIRECTIONALS



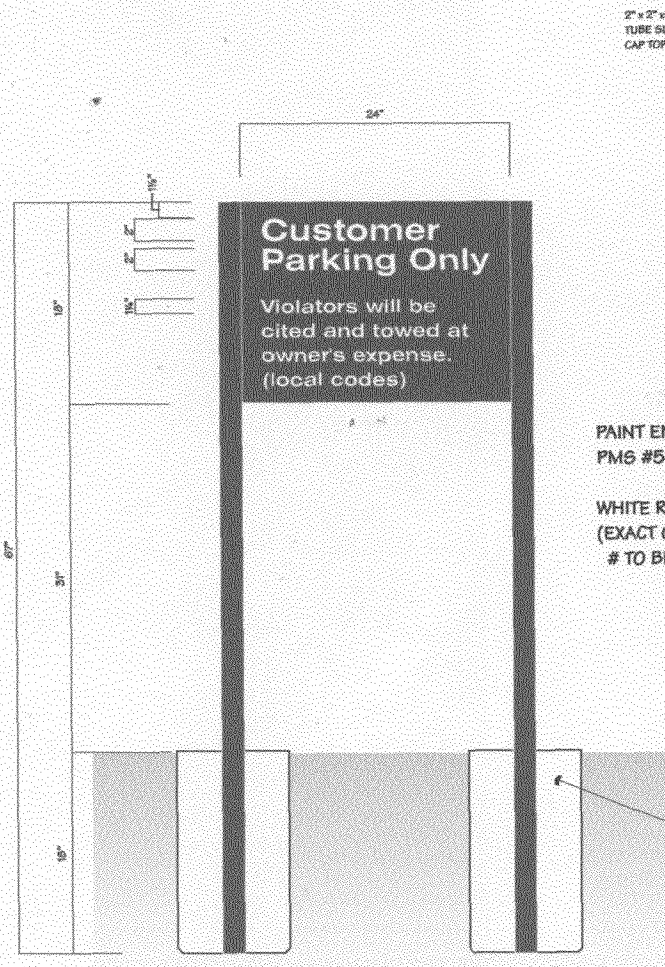

S/F ELEVATION

SCALE: 3/4" = 1'-0"

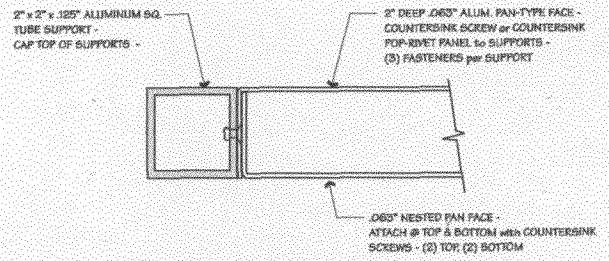

PLAN SECTION

NOT TO SCALE

PAINT ENTIRE DIRECTIONAL TO MATCH
PM6 #540 DARK BLUE

WHITE REFLECTIVE VINYL COPY
(EXACT CODE INFORMATION & PHONE
TO BE DETERMINED)

9" DIA. X 18" DEEP CONC. PIER

1211 N. 7th Street
Grand Junction, CO
Location # CFC023

Revised: 08/04/04



BANK OF THE WEST



New Signage Program

Photo Number CFCO23-G

Type S/F PANELS

Height 18"

Width 12"

Depth _____

Overall above grade _____

- | | |
|---|---|
| <input type="checkbox"/> Pylon/Monument | <input checked="" type="checkbox"/> Wall Mount |
| <input type="checkbox"/> Directional | <input type="checkbox"/> Vinyl |
| <input type="checkbox"/> Channel letters | <input type="checkbox"/> Other |
| <input checked="" type="checkbox"/> Single Face | <input type="checkbox"/> Double Face |
| <input type="checkbox"/> Illuminated | <input checked="" type="checkbox"/> Non-Illuminated |

Comments _____



New Signage MFR & INSTALL

(3) S/F REPLACEMENT
 PANELS

Comments LOGOS/NAMES NOT
 ALLOWED ON 3 SQ.FT.
 DIRECTIONALS

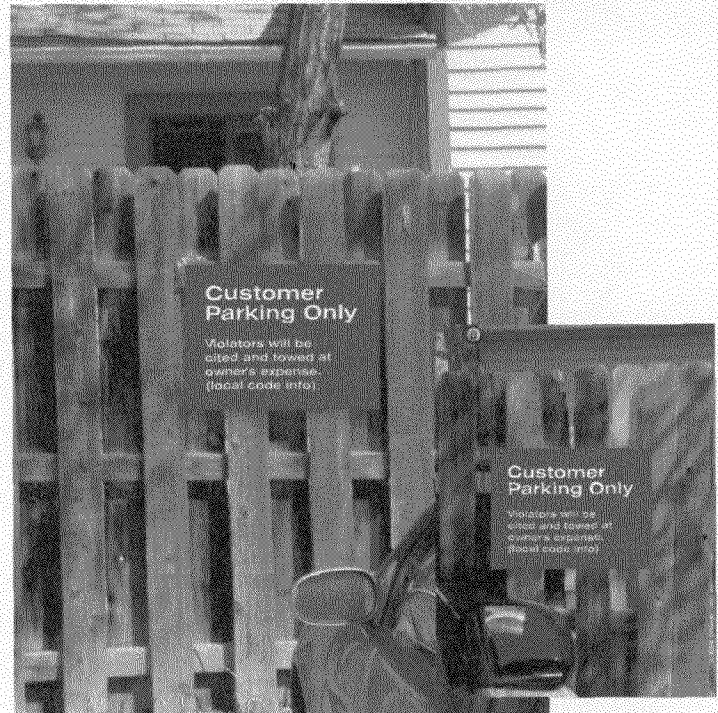

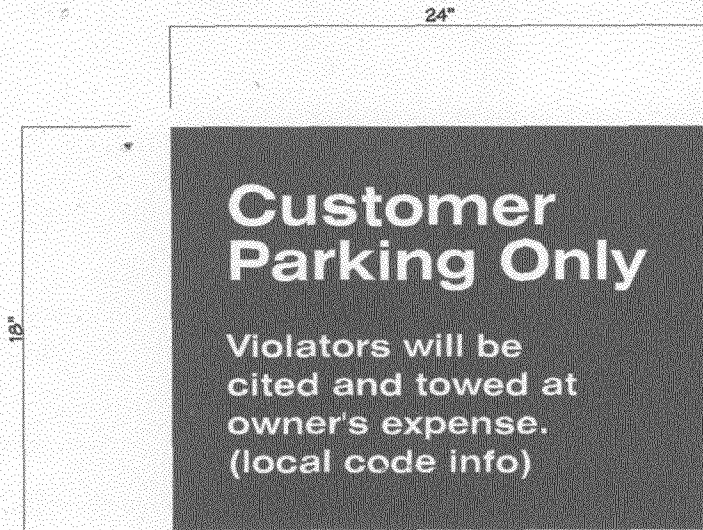

1" DEEP .063" ALUM. PAN-TYPE FACE /
PAINT PANEL TO MATCH PMS #540 DARK BLUE

WHITE REFLECTIVE VINYL COPY (EXACT CODE INFO &
PHONE NUMBER TO BE DETERMINED)

S/F PANEL DETAIL

(3) REQUIRED - MFR. & INSTALL

SCALE: 1/4" = 1'-0"

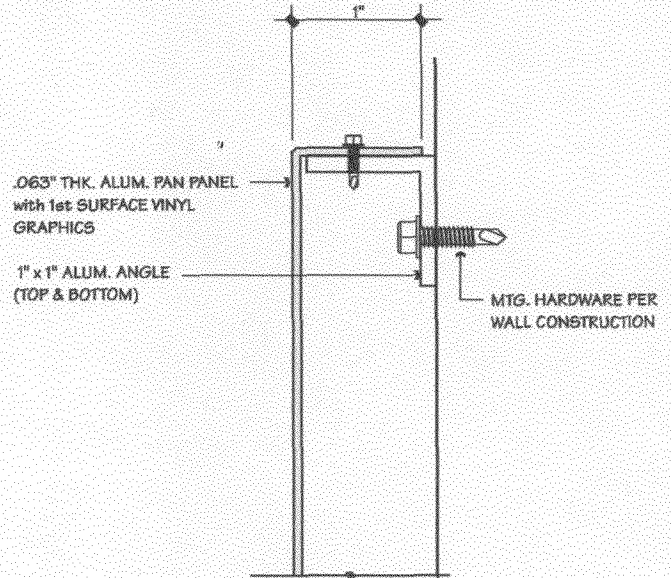

PLAN SECTION

1211 N. 7th Street
Grand Junction, CO
Location # CFCO23

Revised: 08/04/04



Photo Number CFCO23-H

Type D/F DIRECTIONAL

Height 18"

Width 40"

Depth _____

Overall above grade 50"

- | | |
|---|---|
| <input type="checkbox"/> Pylon/Monument | <input type="checkbox"/> Wall Mount |
| <input checked="" type="checkbox"/> Directional | <input type="checkbox"/> Vinyl |
| <input type="checkbox"/> Channel letters | <input type="checkbox"/> Other |
| <input type="checkbox"/> Single Face | <input checked="" type="checkbox"/> Double Face |
| <input type="checkbox"/> Illuminated | <input checked="" type="checkbox"/> Non-Illuminated |

Comments _____



New Signage MFR & INSTALL

(1) D/F DIRECTIONAL

Comments LOGOS/NAMES NOT ALLOWED ON 3 SQ.FT. DIRECTIONALS



1211 N. 7th Street
Grand Junction, CO
Location # CFCO23

Revised: 08/04/04



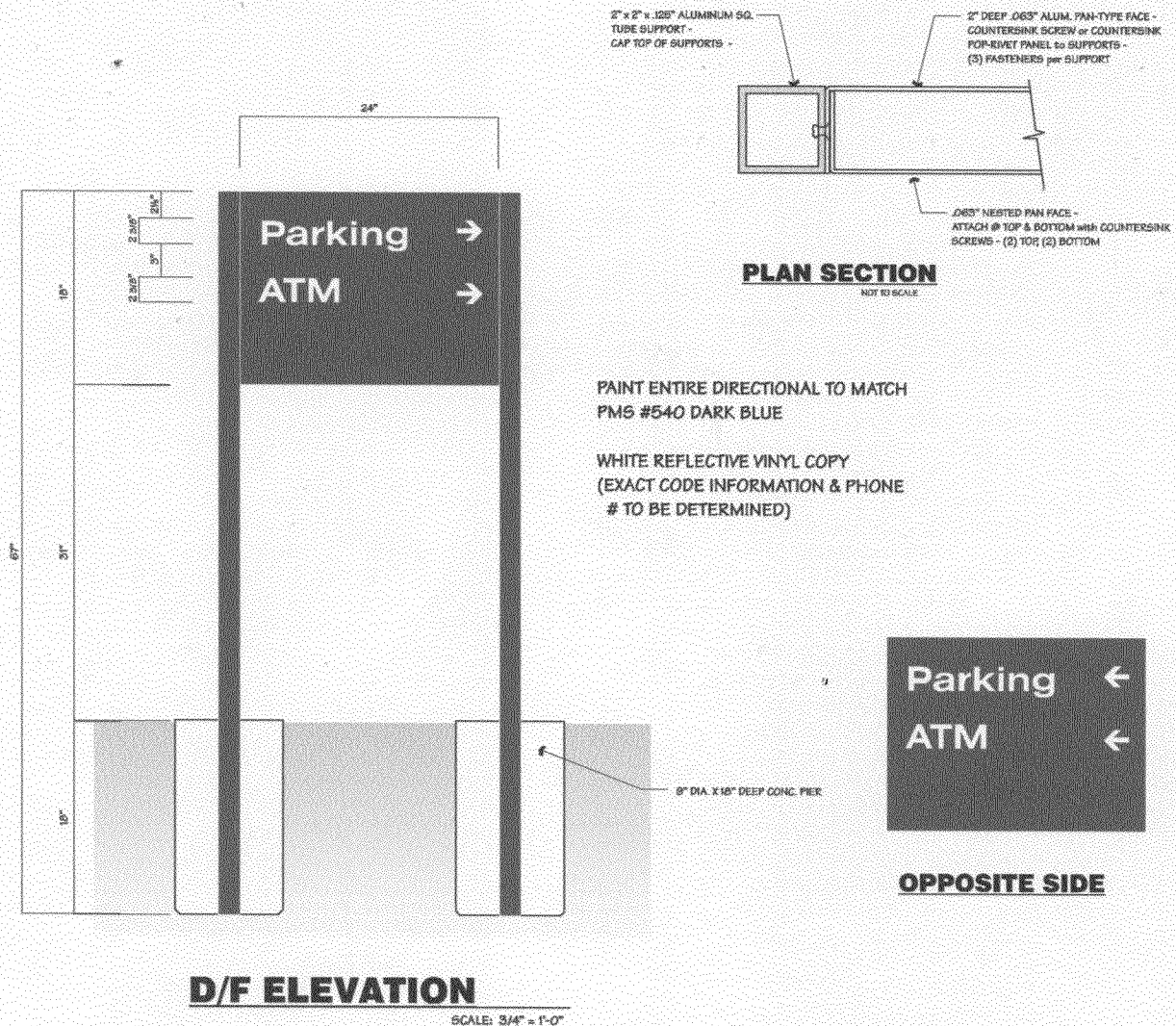

BANK OF THE WEST



New Signage Program

Photo Number CFCO23-1

Type D/F DIRECTIONAL

Height 18"

Width 40"

Depth _____

Overall above grade 37"

- | | |
|---|---|
| <input type="checkbox"/> Pylon/Monument | <input type="checkbox"/> Wall Mount |
| <input checked="" type="checkbox"/> Directional | <input type="checkbox"/> Vinyl |
| <input type="checkbox"/> Channel letters | <input type="checkbox"/> Other |
| <input type="checkbox"/> Single Face | <input checked="" type="checkbox"/> Double Face |
| <input type="checkbox"/> Illuminated | <input checked="" type="checkbox"/> Non-Illuminated |

Comments _____



New Signage MFR & INSTALL

(1) D/F DIRECTIONAL

Comments LOGOS/NAMES NOT
ALLOWED ON 3 SQ.FT.
DIRECTIONALS



1211 N. 7th Street
Grand Junction, CO
Location # CFCO23

Revised: 08/04/04



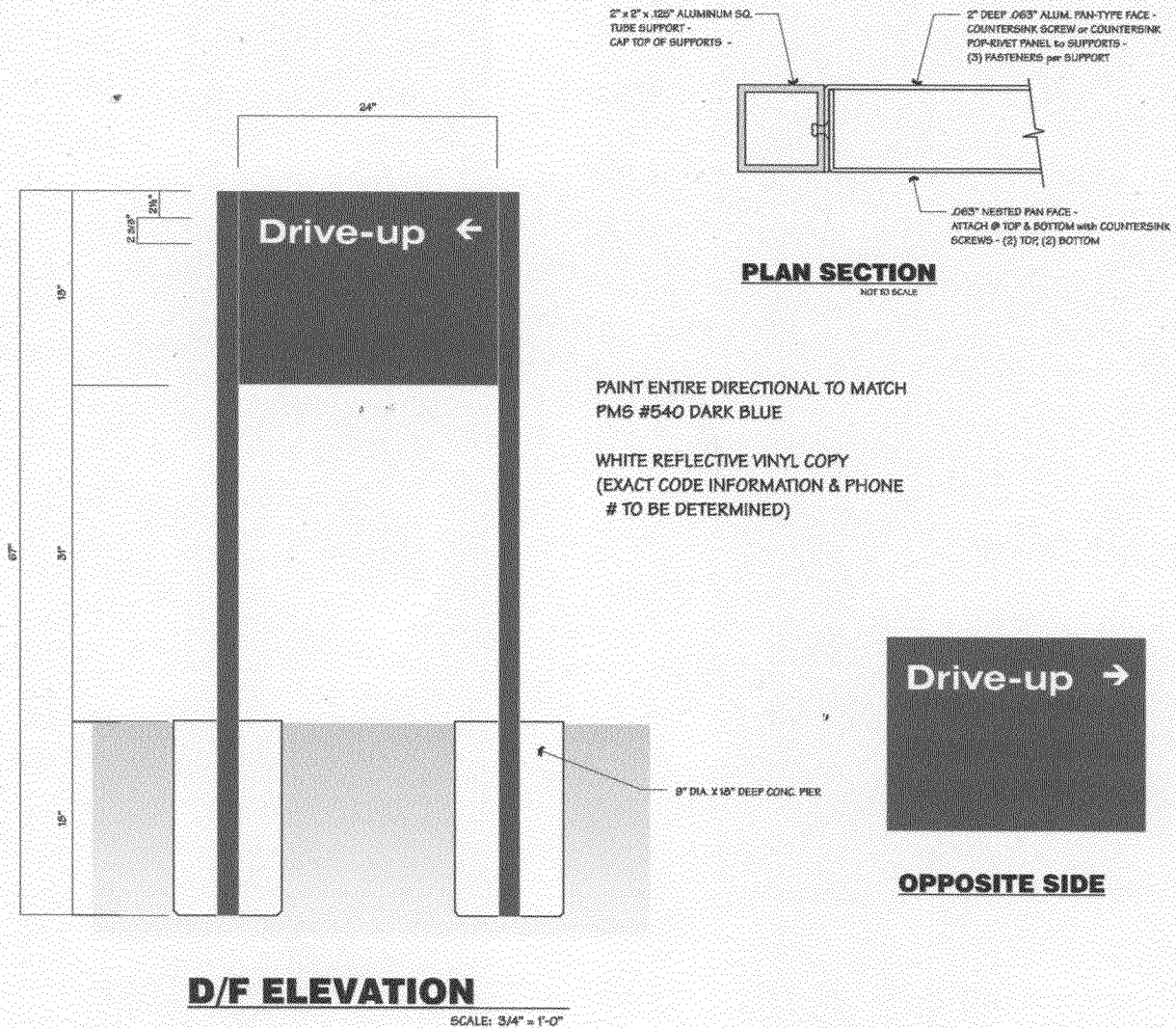

1211 N. 7th Street
Grand Junction, CO
Location # CFCO23

Revised: 08/04/04



BANK OF THE WEST



New Signage Program

Photo Number CFCO23-J

Type S/F DIRECTIONAL

Height 24"

Width 24"

Depth _____

Overall above grade _____

- | | |
|---|---|
| <input type="checkbox"/> Pylon/Monument | <input type="checkbox"/> Wall Mount |
| <input checked="" type="checkbox"/> Directional | <input type="checkbox"/> Vinyl |
| <input type="checkbox"/> Channel letters | <input type="checkbox"/> Other |
| <input checked="" type="checkbox"/> Single Face | <input type="checkbox"/> Double Face |
| <input type="checkbox"/> Illuminated | <input checked="" type="checkbox"/> Non-Illuminated |

Comments _____



New Signage MFR & INSTALL

(1) D/F DIRECTIONAL

Comments LOGOS/NAMES NOT
ALLOWED ON 3 SQ.FT.
DIRECTIONALS



1211 N. 7th Street
Grand Junction, CO
Location # CFCO23

Revised: 08/04/04



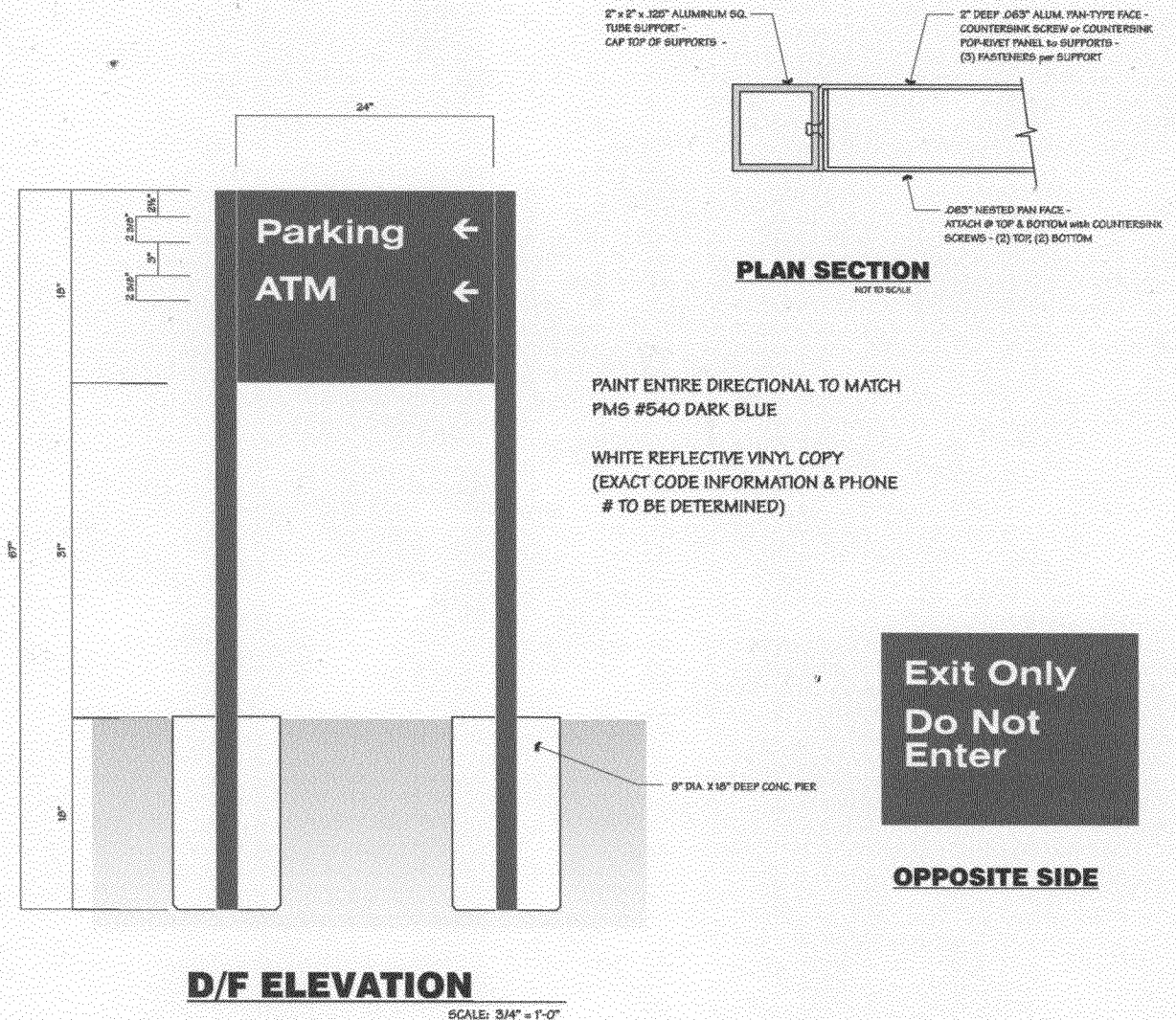



Photo Number CFCO23-K

Type S/F DIRECTIONAL

Height 24"

Width 24"

Depth _____

Overall above grade _____

- | | |
|---|---|
| <input type="checkbox"/> Pylon/Monument | <input type="checkbox"/> Wall Mount |
| <input checked="" type="checkbox"/> Directional | <input type="checkbox"/> Vinyl |
| <input type="checkbox"/> Channel letters | <input type="checkbox"/> Other |
| <input checked="" type="checkbox"/> Single Face | <input type="checkbox"/> Double Face |
| <input type="checkbox"/> Illuminated | <input checked="" type="checkbox"/> Non-Illuminated |

Comments _____



New Signage MFR & INSTALL

(1) S/F DIRECTIONAL

Comments LOGOS/NAMES NOT
ALLOWED ON 3 SQ.FT.
DIRECTIONALS



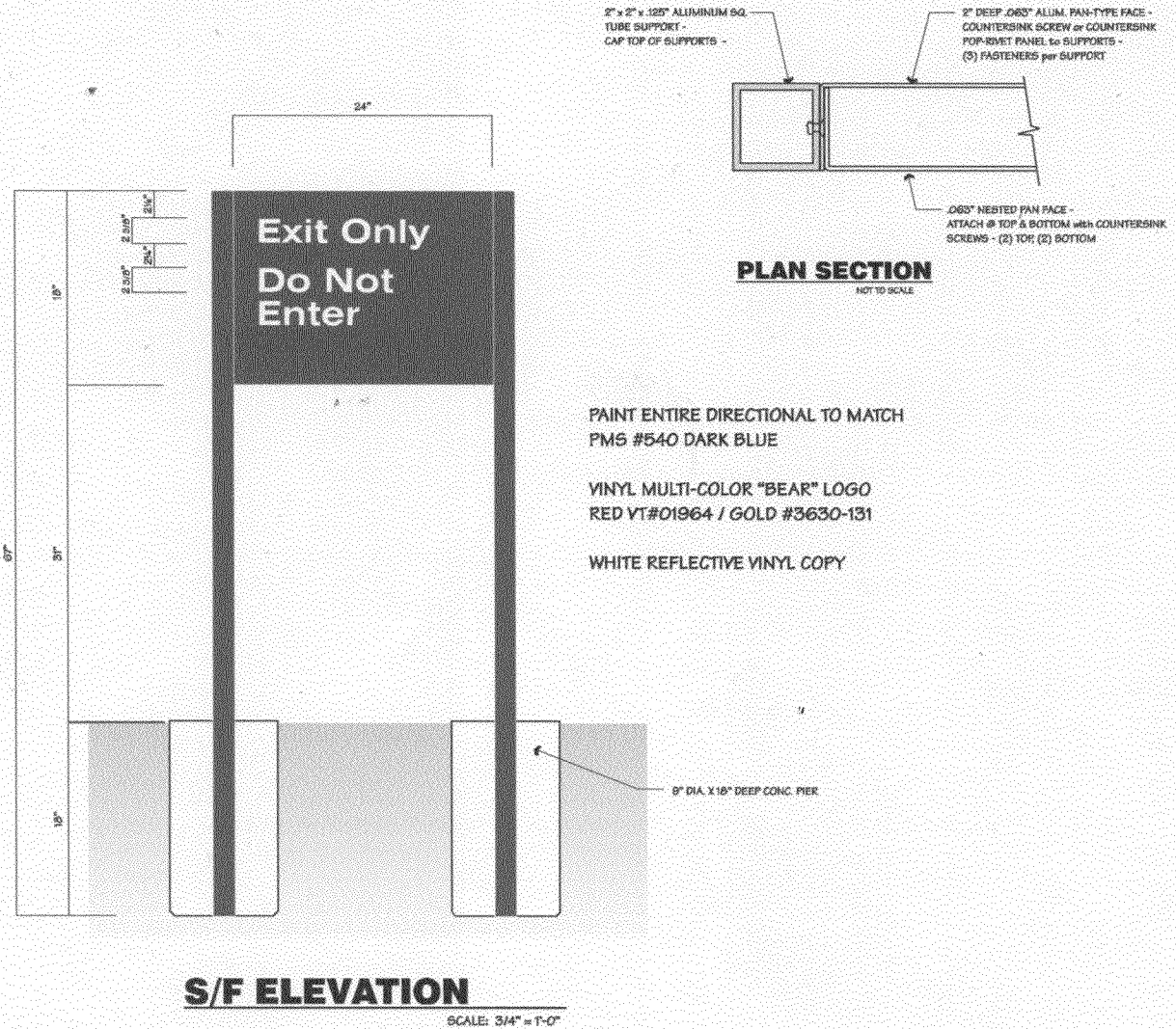

BANK OF THE WEST



New Signage Program

Photo Number CFCO23-L

Type NO EXISTING SIGNAGE

Height _____

Width _____

Depth _____

Overall above grade _____

- | | |
|--|--|
| <input type="checkbox"/> Pylon/Monument | <input type="checkbox"/> Wall Mount |
| <input type="checkbox"/> Directional | <input type="checkbox"/> Vinyl |
| <input type="checkbox"/> Channel letters | <input type="checkbox"/> Other |
| <input type="checkbox"/> Single Face | <input type="checkbox"/> Double Face |
| <input type="checkbox"/> Illuminated | <input type="checkbox"/> Non-Illuminated |

Comments _____



New Signage MFR & INSTALL

(1) S/F PANEL

Comments _____



1211 N. 7th Street
Grand Junction, CO
Location # CFCO23

Revised: 08/04/04





1" DEEP .063" ALUM. PAN-TYPE FACE -
COUNTERSINK SCREW or COUNTERSINK
POP-RIVET PANEL to SUPPORTS -

PAINT PANEL TO MATCH PMS #540 DARK BLUE
WHITE REFLECTIVE VINYL COPY

S/F PANEL DETAIL

(2) REQUIRED

SCALE: 1"=1'-0"

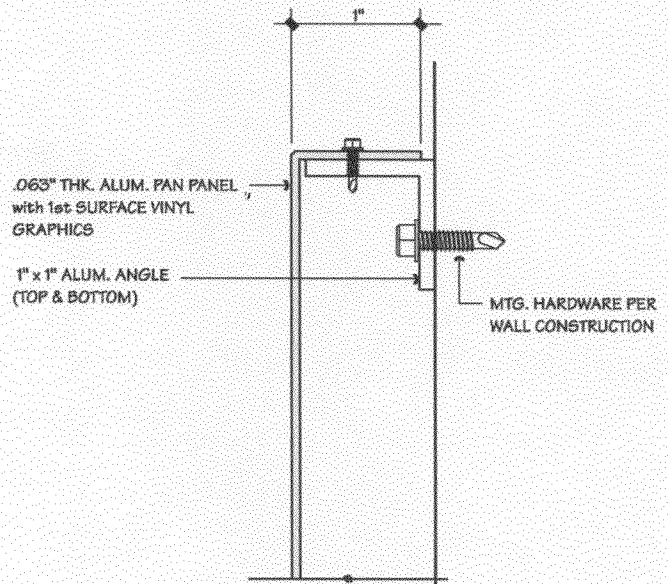

PLAN SECTION



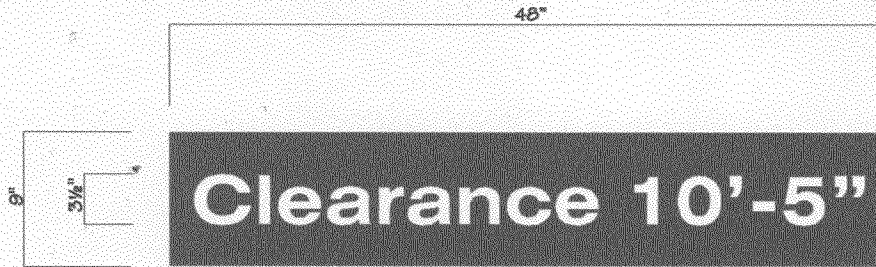

1" DEEP .063" ALUM. PAN-TYPE FACE -
COUNTERSINK SCREW or COUNTERSINK
POP-RIVET PANEL to SUPPORTS -

PAINT PANEL TO MATCH PMG #540 DARK BLUE
WHITE REFLECTIVE VINYL COPY

S/F PANEL DETAIL

(2) REQUIRED

SCALE: 1" = 1'-0"

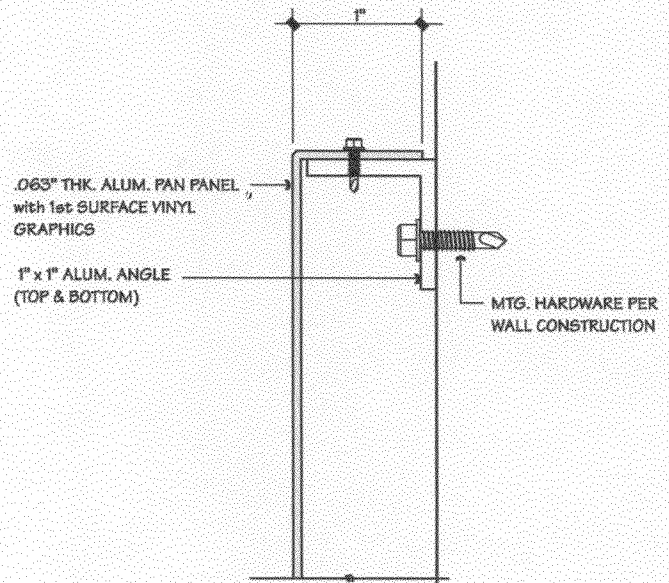

PLAN SECTION



Photo Number CFCO23-M

Type NO EXISTING SIGNAGE

Height _____

Width _____

Depth _____

Overall above grade _____

- | | |
|--|--|
| <input type="checkbox"/> Pylon/Monument | <input type="checkbox"/> Wall Mount |
| <input type="checkbox"/> Directional | <input type="checkbox"/> Vinyl |
| <input type="checkbox"/> Channel letters | <input type="checkbox"/> Other |
| <input type="checkbox"/> Single Face | <input type="checkbox"/> Double Face |
| <input type="checkbox"/> Illuminated | <input type="checkbox"/> Non-Illuminated |

Comments _____



New Signage MFR & INSTALL

(4) L-SHAPED

BLADE SIGNS

Comments _____

██████ 7th Street
██████ Junction, CO
Location # CFCO23

Revised: 08/04/04



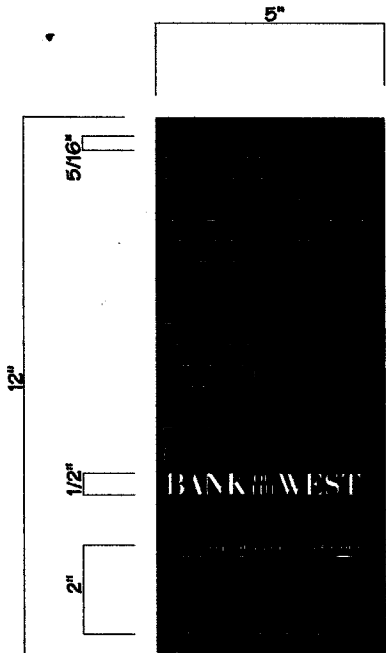

.125" ALUMINUM V-SHAPED BLADE SIGNS /
 ATTACHED TO EXISTING ATM UNITS W/ FOAM
 TAPE AND SILICONE -

PAINT ENTIRE SIGN TO MATCH
 PMS #540 DARK BLUE -

WHITE VINYL COPY -

BLADE SIGN DETAIL

(4) REQUIRED - MFR & INSTALL

3" = 1'-0"

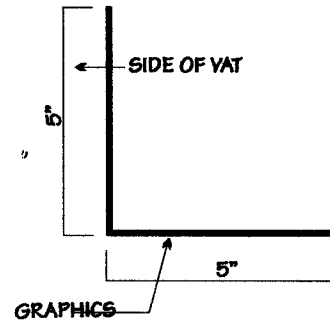

PLAN VIEW

3" = 1'-0"



BANK OF THE WEST



New Signage Program

Photo Number CFCO23-N

Type INTERIOR ELEVATION

Height _____

Width _____

Depth _____

Overall above grade _____

- | | |
|--|--|
| <input type="checkbox"/> Pylon/Monument | <input type="checkbox"/> Wall Mount |
| <input type="checkbox"/> Directional | <input type="checkbox"/> Vinyl |
| <input type="checkbox"/> Channel letters | <input type="checkbox"/> Other |
| <input type="checkbox"/> Single Face | <input type="checkbox"/> Double Face |
| <input type="checkbox"/> Illuminated | <input type="checkbox"/> Non-Illuminated |

Comments _____



New Signage MFR & INSTALL

(1) SET 15" FCO

GRAPHICS

Comments _____



1211 N. 7th Street
Grand Junction, CO
Location # CFCO23

Revised: 08/04/04



BANK OF THE WEST



New Signage Program

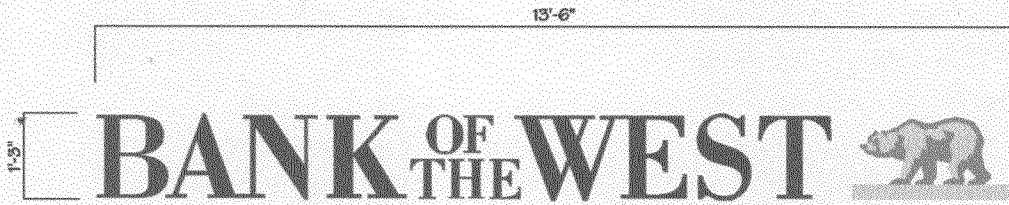

F/C/O LETTERS & LOGO LAYOUT

3/8" = 1'-0"

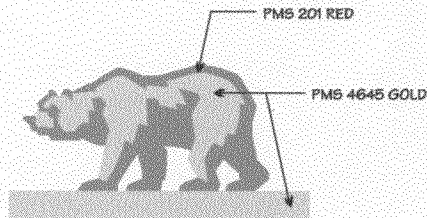

LOGO DETAIL

NOT TO SCALE

1" THK. CLEAR PLEX F.C.O. LETTERS /
FACES & RETURNS PTD. TO MATCH
PMS 540C DARK BLUE -

LOGO COLORS AS NOTED / RETURNS PTD. PMS
540C DARK BLUE

ATTACH F.C.O. LETTERS TO WALL
with STUDS AND SILICONE ADHESIVE

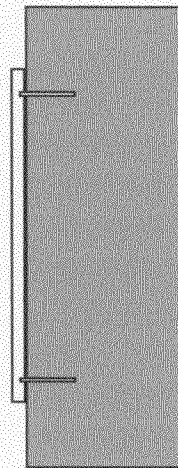

SECTION DETAIL

NOT TO SCALE

1211 N. 7th Street
Grand Junction, CO
Location # CFCO23

Revised: 08/04/04



Chandler
Signs

BANK OF THE WEST



New Signage Program

Photo Number CFCO23-0

Type S/F PANEL

Height 1'-6"

Width 5'-0"

Depth _____

Overall above grade _____

- | | |
|---|---|
| <input type="checkbox"/> Pylon/Monument | <input type="checkbox"/> Wall Mount |
| <input type="checkbox"/> Directional | <input type="checkbox"/> Vinyl |
| <input type="checkbox"/> Channel letters | <input type="checkbox"/> Other |
| <input checked="" type="checkbox"/> Single Face | <input type="checkbox"/> Double Face |
| <input type="checkbox"/> Illuminated | <input checked="" type="checkbox"/> Non-Illuminated |

Comments _____



New Signage REMOVAL ONLY

Comments _____

1211 N. 7th Street
Grand Junction, CO
Location # CFCO23

Revised: 08/04/04



BANK OF THE WEST



New Signage Program

Photo Number CFCO23-P

Type WINDOW VINYL

Height _____

Width _____

Depth _____

Overall above grade _____

- | | |
|--|---|
| <input type="checkbox"/> Pylon/Monument | <input type="checkbox"/> Wall Mount |
| <input type="checkbox"/> Directional | <input checked="" type="checkbox"/> Vinyl |
| <input type="checkbox"/> Channel letters | <input type="checkbox"/> Other |
| <input type="checkbox"/> Single Face | <input type="checkbox"/> Double Face |
| <input type="checkbox"/> Illuminated | <input type="checkbox"/> Non-Illuminated |

Comments _____



New Signage REMOVAL ONLY

Comments _____

1211 N. 7th Street
Grand Junction, CO
Location # CFCO23

Revised: 08/04/04



BANK OF THE WEST



New Signage Program

Photo Number CFCO23-Q

Type DOOR VINYL

Height _____

Width _____

Depth _____

Overall above grade _____

- | | |
|--|---|
| <input type="checkbox"/> Pylon/Monument | <input type="checkbox"/> Wall Mount |
| <input type="checkbox"/> Directional | <input checked="" type="checkbox"/> Vinyl |
| <input type="checkbox"/> Channel letters | <input type="checkbox"/> Other |
| <input type="checkbox"/> Single Face | <input type="checkbox"/> Double Face |
| <input type="checkbox"/> Illuminated | <input type="checkbox"/> Non-Illuminated |

Comments _____



New Signage MFR & INSTALL

(1) SET STANDARD

DOOR VINYL

Comments _____

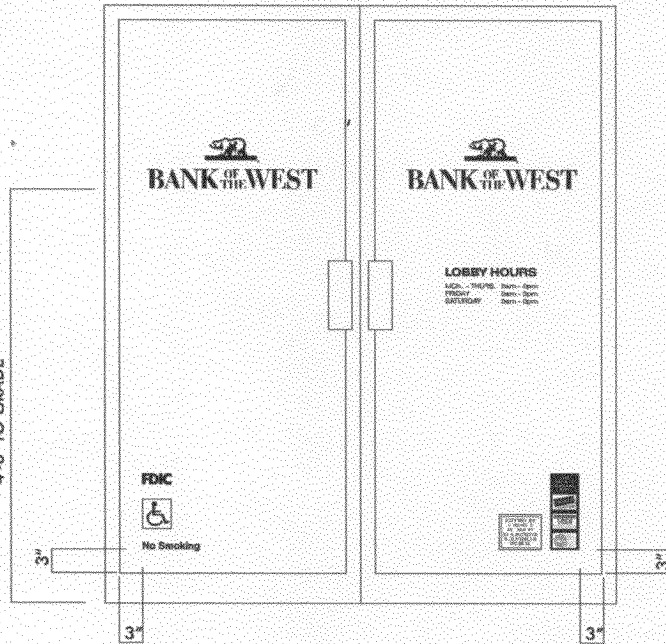

1211 N. 7th Street
 Grand Junction, CO
 Location # CFCO23

Revised: 08/04/04



BANK OF THE WEST



New Signage Program

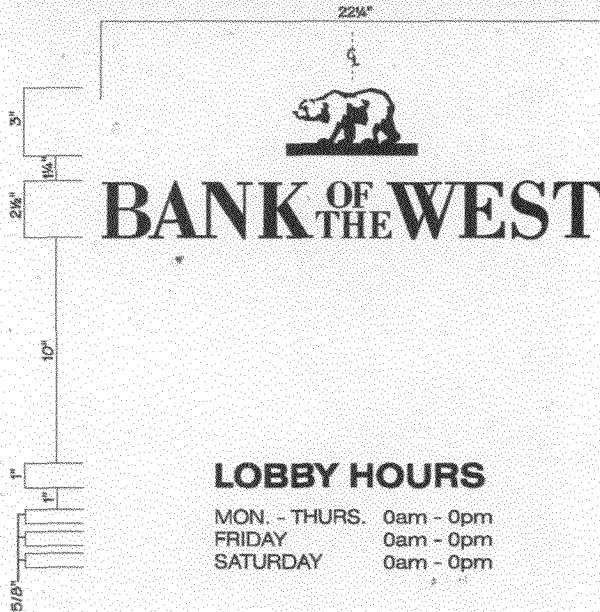

LOBBY HOURS

MON. - THURS. 0am - 0pm
 FRIDAY 0am - 0pm
 SATURDAY 0am - 0pm

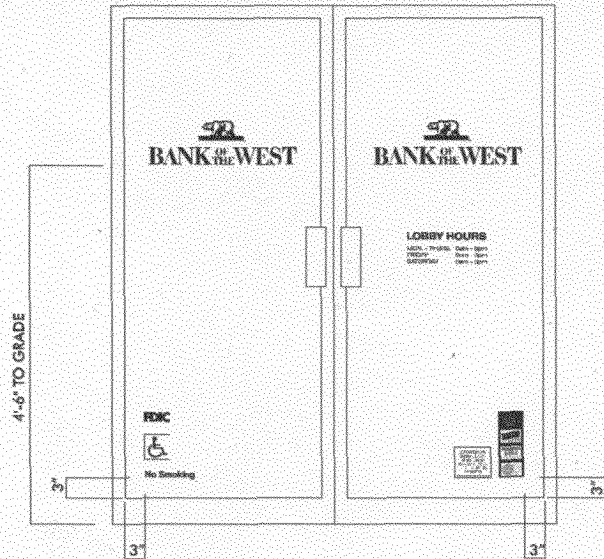

ELEVATION

n.t.s.

VINYL DETAIL - LAYOUT 1

7725-11 PEARL GRAY
 VINYL GRAPHICS FOR DOUBLE-DOOR LAYOUT /
 1ST SURFACE APPLIED -

SCALE: 1/8" = 1'-0"

LEFT DOOR - LOGO
 RIGHT DOOR - LOGO & HOURS

ALL HOURS ARE DETERMINED PER LOCATION

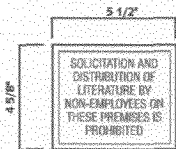

VINYL DECAL

SCALE: 1/8" = 1'-0"
 DIGITALLY PRINTED VINYL DECAL - BLUE COPY
 AND BORDER ON A WHITE BACKGROUND -
 FIRST SURFACE APPLIED



No Smoking

VINYL DECAL

SCALE: 1/8" = 1'-0"
 7725-11 PEARL GRAY VINYL GRAPHICS
 FIRST SURFACE APPLIED



VINYL DECAL

SCALE: 1/8" = 1'-0"
 DIGITALLY PRINTED VINYL DECAL - MULTI-COLOR -
 FIRST SURFACE APPLIED

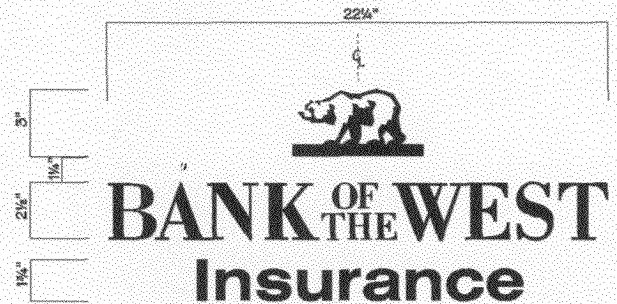

BANK OF THE WEST
Insurance

MON. - THURS. 0am - 0pm
 FRIDAY 0am - 0pm
 SATURDAY 0am - 0pm

VINYL DETAIL

7725-11 PEARL GRAY VINYL GRAPHICS /
 1ST SURFACE APPLIED

SCALE: 1/8" = 1'-0"

ALL HOURS ARE DETERMINED PER LOCATION

1211 N. 7th Street
 Grand Junction, CO
 Location # CFCO23

Revised: 08/04/04



BANK OF THE WEST



New Signage Program

Photo Number CFCO23-R

Type DOOR VINYL

Height _____

Width _____

Depth _____

Overall above grade _____

- | | |
|--|---|
| <input type="checkbox"/> Pylon/Monument | <input type="checkbox"/> Wall Mount |
| <input type="checkbox"/> Directional | <input checked="" type="checkbox"/> Vinyl |
| <input type="checkbox"/> Channel letters | <input type="checkbox"/> Other |
| <input type="checkbox"/> Single Face | <input type="checkbox"/> Double Face |
| <input type="checkbox"/> Illuminated | <input type="checkbox"/> Non-Illuminated |

Comments _____



New Signage MFR & INSTALL

(1) SET STANDARD

DOOR VINYL

Comments _____

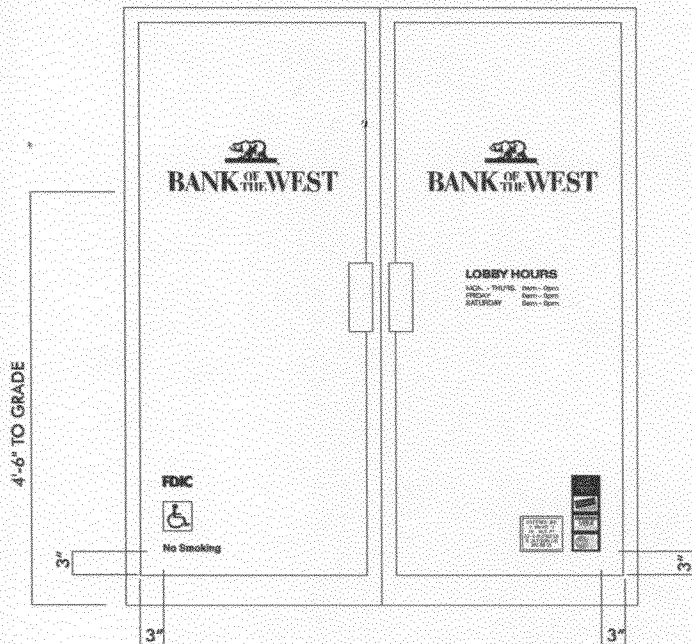

1211 N. 7th Street
 Grand Junction, CO
 Location # CFCO23

Revised: 08/04/04



BANK OF THE WEST



New Signage Program

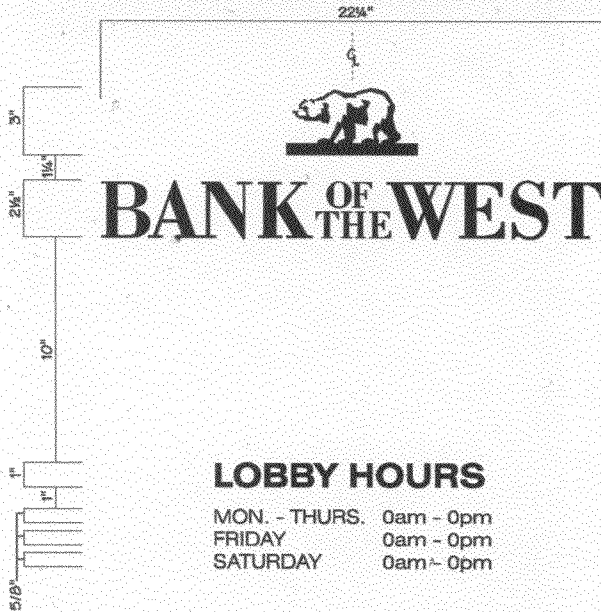

LOBBY HOURS

MON. - THURS. 0am - 0pm
 FRIDAY 0am - 0pm
 SATURDAY 0am - 0pm

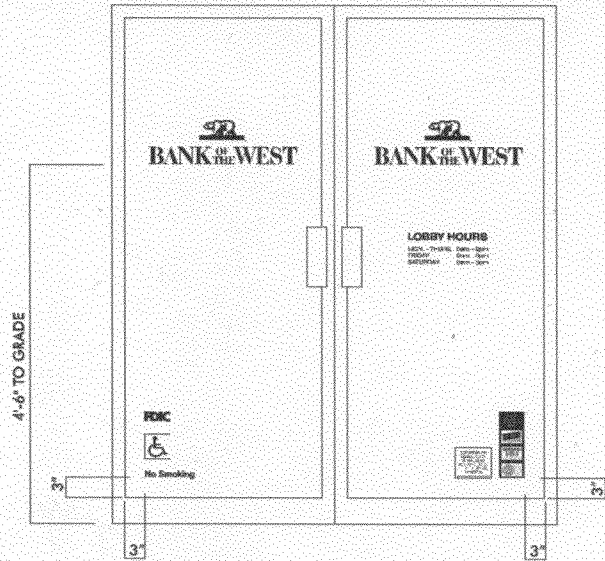

ELEVATION

R.T.S.

VINYL DETAIL - LAYOUT 1

7725-11 PEARL GRAY
 VINYL GRAPHICS FOR DOUBLE-DOOR LAYOUT /
 1ST SURFACE APPLIED -

SCALE: 1/4" = 1'-0"

LEFT DOOR - LOGO
 RIGHT DOOR - LOGO & HOURS

ALL HOURS ARE DETERMINED PER LOCATION

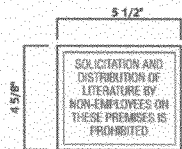

VINYL DECAL

SCALE: 1/4" = 1'-0"
 DIGITALLY PRINTED VINYL DECAL - BLUE COPY
 AND BORDER ON A WHITE BACKGROUND -

FIRST SURFACE APPLIED

FDIC



No Smoking

VINYL DECAL

7725-11 PEARL GRAY VINYL GRAPHICS
 FIRST SURFACE APPLIED

SCALE: 1/4" = 1'-0"



VINYL DECAL

SCALE: 1/4" = 1'-0"
 DIGITALLY PRINTED VINYL DECAL - MULTI-COLOR -
 FIRST SURFACE APPLIED

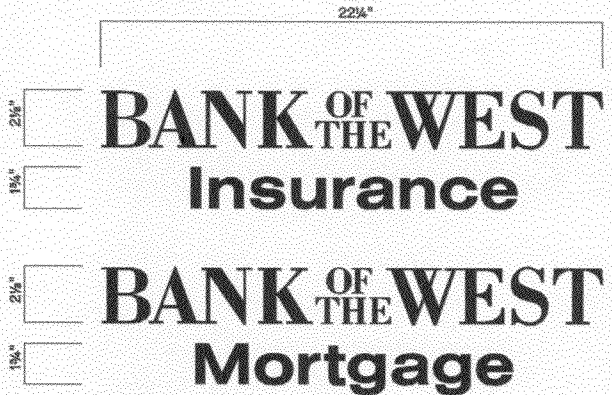

VINYL DETAIL

7725-11 PEARL GRAY VINYL GRAPHICS /
 1ST SURFACE APPLIED -

SCALE: 1/4" = 1'-0"

1211 N. 7th Street
 Grand Junction, CO
 Location # CFCO23

Revised: 08/04/04



Chandler
 Signs

BANK OF THE WEST



New Signage Program

Photo Number CFCO23-S

Type WINDOW VINYL

Height _____

Width _____

Depth _____

Overall above grade _____

- | | |
|--|---|
| <input type="checkbox"/> Pylon/Monument | <input type="checkbox"/> Wall Mount |
| <input type="checkbox"/> Directional | <input checked="" type="checkbox"/> Vinyl |
| <input type="checkbox"/> Channel letters | <input type="checkbox"/> Other |
| <input type="checkbox"/> Single Face | <input type="checkbox"/> Double Face |
| <input type="checkbox"/> Illuminated | <input type="checkbox"/> Non-Illuminated |

Comments _____



New Signage MFR & INSTALL

(1) SET STANDARD

WINDOW VINYL

Comments _____

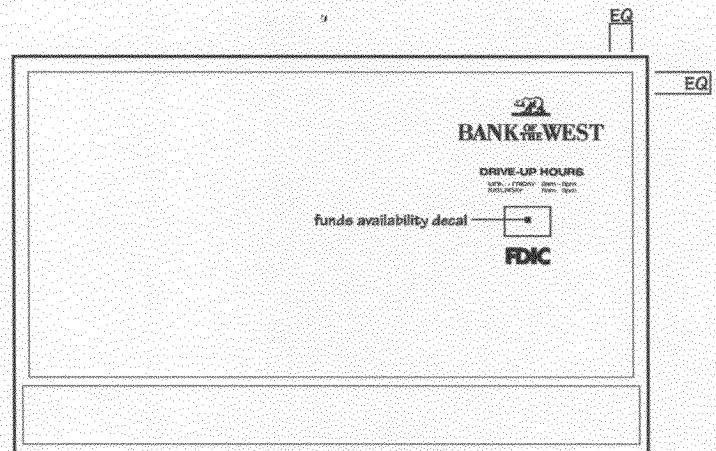

1211 N. 7th Street
Grand Junction, CO
Location # CFCO23

Revised: 08/04/04



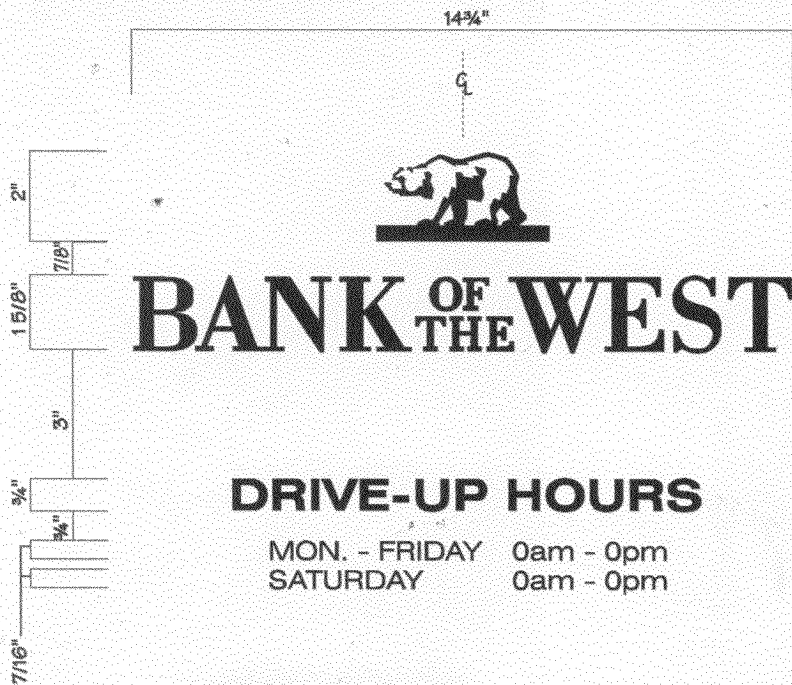

7725-11 PEARL GREY
VINYL GRAPHICS FOR DRIVE-UP WINDOW /
1ST SURFACE APPLIED -

ALL HOURS ARE DETERMINED PER LOCATION

VINYL DETAIL

(1) SET REQUIRED

SCALE: 3"=1'-0"



VINYL DETAIL

(1) SET REQUIRED

SCALE: 3"=1'-0"

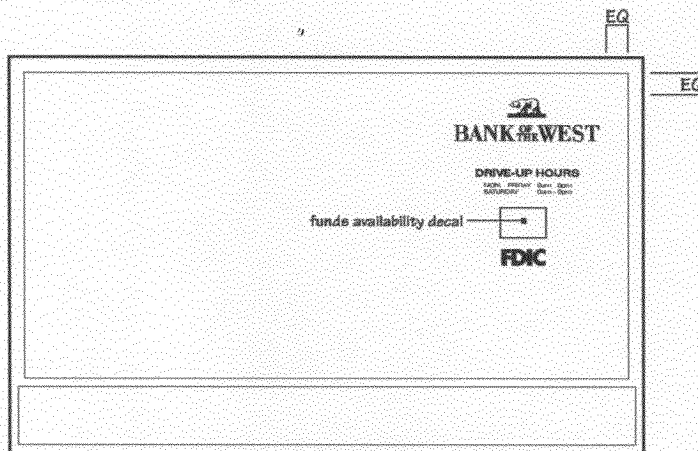

ELEVATION

N.T.S.

