

5
A



SIGN PERMIT

Community Development Department
250 North 5th Street
Grand Junction, CO 81501
(970) 244-1430

Permit No. _____
Date Submitted 11-05
FEE \$ 25.00
Tax Schedule 2945-044-04-002
Zone C-1

BUSINESS NAME Bank of The West
STREET ADDRESS 2452 E. Road 81505
PROPERTY OWNER 2452 Limited Liability Co.
OWNER ADDRESS PO Box 55245 GJ, 81505

CONTRACTOR Western Neon Sign Co. Inc
LICENSE NO. 2050455
ADDRESS 3183 Hall Ave, G.J., Co. 81501
TELEPHONE NO. 523-4045

- 1. FLUSH WALL 2 Square Feet per Linear Foot of Building Facade
- Face Change Only (2,3 & 4):
- 2. ROOF 2 Square Feet per Linear Foot of Building Facade
- 3. FREE-STANDING 2 Traffic Lanes - 0.75 Square Feet x Street Frontage
- 4 or more Traffic Lanes - 1.5 Square Feet x Street Frontage
- 4. PROJECTING 0.5 Square Feet per each Linear Foot of Building Facade

Existing Externally or Internally Illuminated - No Change in Electrical Service Non-Illuminated

(1 - 4) Area of Proposed Sign 32 cabinet Square Feet Revinyl top 13" x 91" = 8' sq ft of surface
(1,2,4) Building Facade 92' Linear Feet F-Road
(1 - 4) Street Frontage 192' Linear Feet
(2,3,4) Height to Top of Sign 6 Feet Clearance to Grade 2 Feet

Existing Signage/Type:	Sq. Ft.
Total Existing:	

● FOR OFFICE USE ONLY ●		
Signage Allowed on Parcel:	<u>F Rd</u>	
Building	<u>184</u>	Sq. Ft.
Free-Standing	<u>288</u>	Sq. Ft.
Total Allowed:	<u>288</u>	Sq. Ft.

COMMENTS: Revinyl to top 13" x 91" of sign face.

NOTE: No sign may exceed 300 square feet. A separate sign permit is required for each sign. Attach a sketch of proposed and existing signage including types, dimensions, lettering, abutting streets, alleys, easements, property lines, and locations. Roof signs shall be manufactured such that no guy wires, braces or supports shall be visible.

[Signature] Applicant's Signature 9-27-05 Date [Signature] Community Development Approval 11-10-05 Date

(White: Community Development) (Canary: Applicant) (Pink: Code Enforcement)

3



SIGN CLEARANCE

Community Development Department
250 North 5th Street
Grand Junction CO 81501
(970) 244-1430

Clearance No. _____
Date Submitted _____
Fee \$ 5.00
Zone C-1

TAX SCHEDULE 2995-044-04-002 CONTRACTOR Western Neon Sign Co, Inc
BUSINESS NAME Bank of The West LICENSE NO. 2050455
STREET ADDRESS 2452 F. Road 81504 ADDRESS 3183 Hall Ave G.J. 81504
PROPERTY OWNER 2452 Limited Liability Corp TELEPHONE NO. 523-4045
OWNER ADDRESS PO Box 55245 G.J. 81505 CONTACT PERSON John

- | | |
|---|--|
| <input checked="" type="checkbox"/> 1. FLUSH WALL | <input checked="" type="checkbox"/> 2 Square Feet per Linear Foot of Building Facade |
| <input type="checkbox"/> 2. ROOF | 2 Square Feet per Linear Foot of Building Facade |
| <input type="checkbox"/> 3. FREE-STANDING | 2 Traffic Lanes - 0.75 Square Feet x Street Frontage |
| | 4 or more Traffic Lanes - 1.5 Square Feet x Street Frontage |
| <input type="checkbox"/> 4. PROJECTING | 0.5 Square Feet per each Linear Foot of Building Facade |
| <input type="checkbox"/> 5. OFF-PREMISE | See #3 Spacing Requirements; Not > 300 Square Feet or < 15 Square Feet |

Externally Illuminated Internally Illuminated Non-Illuminated

(1 - 5) Area of Proposed Sign: 100 Square Feet Road
(1,2,4) Building Façade: 100' Linear Feet at 1/2 Building Façade Direction: North South East West
(1 - 4) Street Frontage: 235 Linear Feet Name of Street: F-Road
(2 - 5) Height to Top of Sign: 50'± Feet Clearance to Grade: 47' Feet
(5) Distance from all Existing Off-Premise Signs within 600 Feet: NA Feet

EXISTING SIGNAGE/TYPE & SQUARE FOOTAGE:

<u>(A)</u>	_____	<u>8</u>	Sq. Ft.
_____	_____	_____	Sq. Ft.
_____	_____	_____	Sq. Ft.
Total Existing:		_____	Sq. Ft.

FOR OFFICE USE ONLY

Signage Allowed on Parcel for ROW:	<u>24 1/2 Rd</u>
Building	<u>200</u> Sq. Ft.
Free-Standing	<u>176</u> Sq. Ft.
Total Allowed:	<u>200</u> Sq. Ft.

COMMENTS: Remove the 142 SqFt Sign + install the new 100 SqFt Sign.

NOTE: No sign may exceed 300 square feet. A separate sign clearance is required for each sign. Attach a sketch, to scale, of proposed and existing signage including types, dimensions and lettering. Attach a plot plan, to scale, showing: abutting streets, alleys, easements, driveways, encroachments, property lines, distances from existing buildings to proposed signs and required setbacks. A SEPARATE PERMIT FROM THE BUILDING DEPARTMENT IS ALSO REQUIRED.

I hereby attest that the information on this form and the attached sketches are true and accurate.

[Signature] 9-27-05 [Signature] 11-10-05
Applicant's Signature Date Community Development Approval Date

(White: Community Development) (Canary: Applicant) (Pink: Building Dept) (Goldenrod: Code Enforcement)



SIGN CLEARANCE

Community Development Department
250 North 5th Street
Grand Junction CO 81501
(970) 244-1430

Clearance No. _____
Date Submitted 11-05
Fee \$ 5.00
Zone C-1

TAX SCHEDULE 2945-044-04-002
BUSINESS NAME Bank of The West
STREET ADDRESS 2452 F. Road 81505
PROPERTY OWNER 2452 Limited Liability Corp
OWNER ADDRESS PO Box 55245 G.J., 81505

CONTRACTOR Western Neon Sign Co. Inc
LICENSE NO. 2050455
ADDRESS 3183 Hall Ave G.J., 81504
TELEPHONE NO. 523-4045
CONTACT PERSON John

- 1. FLUSH WALL X 2 Square Feet per Linear Foot of Building Facade
- 2. ROOF 2 Square Feet per Linear Foot of Building Facade
- 3. FREE-STANDING 2 Traffic Lanes - 0.75 Square Feet x Street Frontage
4 or more Traffic Lanes - 1.5 Square Feet x Street Frontage
- 4. PROJECTING 0.5 Square Feet per each Linear Foot of Building Facade
- 5. OFF-PREMISE See #3 Spacing Requirements; Not > 300 Square Feet or < 15 Square Feet

Externally Illuminated Internally Illuminated Non-Illuminated

(1-5) Area of Proposed Sign: 100' Square Feet 24 1/2 Road
(1,2,4) Building Façade: 100' Linear Feet Building Façade Direction: North South East West
(1-4) Street Frontage: 235 Linear Feet Name of Street: _____
(2-5) Height to Top of Sign: 50' Feet Clearance to Grade: 47 Feet
(5) Distance from all Existing Off-Premise Signs within 600 Feet: AA Feet

EXISTING SIGNAGE/TYPE & SQUARE FOOTAGE:

(A)^(F) = 8 (B) = 100^(24 1/2) 108 Sq. Ft.

Total Existing: _____ Sq. Ft.

FOR OFFICE USE ONLY

Signage Allowed on Parcel for ROW: 24 1/2 Rd
Building 200 Sq. Ft.
Free-Standing 176 Sq. Ft.
Total Allowed: 200 Sq. Ft.

COMMENTS: Remove existing wall sign + install new wall sign

NOTE: No sign may exceed 300 square feet. A separate sign clearance is required for each sign. Attach a sketch, to scale, of proposed and existing signage including types, dimensions and lettering. Attach a plot plan, to scale, showing: abutting streets, alleys, easements, driveways, encroachments, property lines, distances from existing buildings to proposed signs and required setbacks. **A SEPARATE PERMIT FROM THE BUILDING DEPARTMENT IS ALSO REQUIRED.**

I hereby attest that the information on this form and the attached sketches are true and accurate.

John Baker 9-27-05 Alishe Inager 11-10-05
Applicant's Signature Date Community Development Approval Date

(White: Community Development) (Canary: Applicant) (Pink: Building Dept) (Goldenrod: Code Enforcement)



SIGN CLEARANCE

Community Development Department
 250 North 5th Street
 Grand Junction CO 81501
 (970) 244-1430

Clearance No. _____
 Date Submitted 11-05
 Fee \$ 5.00
 Zone C-1

TAX SCHEDULE 2945-044-04-002
 BUSINESS NAME Bank of The West
 STREET ADDRESS 2452 F Road 81505
 PROPERTY OWNER 2452 Limited Liability Corp
 OWNER ADDRESS PO Box 25245 G.J. 81505

CONTRACTOR Western Neon Sign Co, Inc
 LICENSE NO. 2050455
 ADDRESS 3183 Hall Ave, 81504
 TELEPHONE NO. 523-4045
 CONTACT PERSON John

- 1. FLUSH WALL 1/2 Square Feet per Linear Foot of Building Facade
- 2. ROOF 2 Square Feet per Linear Foot of Building Facade
- 3. FREE-STANDING 2 Traffic Lanes - 0.75 Square Feet x Street Frontage
- 4. PROJECTING 4 or more Traffic Lanes - 1.5 Square Feet x Street Frontage
- 5. OFF-PREMISE 0.5 Square Feet per each Linear Foot of Building Facade
- See #3 Spacing Requirements; Not > 300 Square Feet or < 15 Square Feet

Externally Illuminated Internally Illuminated Non-Illuminated

(1 - 5) Area of Proposed Sign: 28' Square Feet F-Road
 (1,2,4) Building Façade: 92 Linear Feet Building Façade Direction: North South East West
 (1 - 4) Street Frontage: 192' Linear Feet Name of Street: F Road
 (2 - 5) Height to Top of Sign: 45' Feet Clearance to Grade: 40 Feet
 (5) Distance from all Existing Off-Premise Signs within 600 Feet: _____ Feet

EXISTING SIGNAGE/TYPE & SQUARE FOOTAGE:

(F) (24 1/2) (24 1/2)
 (A) = 8 (B) = 100 (C) = 28 136 Sq. Ft.
 _____ Sq. Ft.
 _____ Sq. Ft.
 Total Existing: _____ Sq. Ft.

FOR OFFICE USE ONLY

Signage Allowed on Parcel for ROW: F Rd
 Building 184 Sq. Ft.
 Free-Standing 288 Sq. Ft.
 Total Allowed: 288 Sq. Ft.

COMMENTS: Remove the 49 sqft sign + Install the 28 sqft sign

NOTE: No sign may exceed 300 square feet. A separate sign clearance is required for each sign. Attach a sketch, to scale, of proposed and existing signage including types, dimensions and lettering. Attach a plot plan, to scale, showing: abutting streets, alleys, easements, driveways, encroachments, property lines, distances from existing buildings to proposed signs and required setbacks. A SEPARATE PERMIT FROM THE BUILDING DEPARTMENT IS ALSO REQUIRED.

I hereby attest that the information on this form and the attached sketches are true and accurate.

[Signature] 9-27-05 [Signature] 11-10-05
 Applicant's Signature Date Community Development Approval Date
 (White: Community Development) (Canary: Applicant) (Pink: Building Dept) (Goldenrod: Code Enforcement)

(E)



SIGN CLEARANCE

Community Development Department
250 North 5th Street
Grand Junction CO 81501
(970) 244-1430

Clearance No.	_____
Date Submitted	<u>11-05</u>
Fee \$	<u>500</u>
Zone	<u>C-1</u>

TAX SCHEDULE	<u>2945-04404-002</u>	CONTRACTOR	<u>Western Neon Sign Co. Inc</u>
BUSINESS NAME	<u>Bank of The West</u>	LICENSE NO.	<u>2050455</u>
STREET ADDRESS	<u>2452 F Road 81505</u>	ADDRESS	<u>3183 Hall Ave. 81504</u>
PROPERTY OWNER	<u>2452 Limited Liability Corp</u>	TELEPHONE NO.	<u>523-4045</u>
OWNER ADDRESS	<u>PO Box 55245 GS, 81505</u>	CONTACT PERSON	<u>John</u>

- | | | | |
|-------------------------------------|------------------|-------------------------------------|--|
| <input checked="" type="checkbox"/> | 1. FLUSH WALL | <input checked="" type="checkbox"/> | 2 Square Feet per Linear Foot of Building Façade |
| <input type="checkbox"/> | 2. ROOF | <input type="checkbox"/> | 2 Square Feet per Linear Foot of Building Façade |
| <input type="checkbox"/> | 3. FREE-STANDING | <input type="checkbox"/> | 2 Traffic Lanes - 0.75 Square Feet x Street Frontage |
| <input type="checkbox"/> | 4. PROJECTING | <input type="checkbox"/> | 4 or more Traffic Lanes - 1.5 Square Feet x Street Frontage |
| <input type="checkbox"/> | 5. OFF-PREMISE | <input type="checkbox"/> | 0.5 Square Feet per each Linear Foot of Building Façade |
| | | <input type="checkbox"/> | See #3 Spacing Requirements; Not > 300 Square Feet or < 15 Square Feet |

Externally Illuminated Internally Illuminated Non-Illuminated

(1 - 5)	Area of Proposed Sign:	<u>28'</u> Square Feet	<u>F. Road</u>
(1,2,4)	Building Façade:	<u>92'</u> Linear Feet	Building Façade Direction: <u>North</u> South East West
(1 - 4)	Street Frontage:	<u>192'</u> Linear Feet	Name of Street: _____
(2 - 5)	Height to Top of Sign:	<u>45'</u> Feet	Clearance to Grade: <u>40'+</u> Feet
(5)	Distance from all Existing Off-Premise Signs within 600 Feet:	<u>N/A</u> Feet	

EXISTING SIGNAGE/TYPE & SQUARE FOOTAGE:

<u>(A) = 8</u>	<u>(B) = 100</u>	<u>(C) = 100</u>	<u>208</u> Sq. Ft.
<u>(D) = 28</u>			<u>28</u> Sq. Ft.
_____	_____	_____	_____ Sq. Ft.
_____	_____	_____	_____ Sq. Ft.
Total Existing:			_____ Sq. Ft.

FOR OFFICE USE ONLY

Signage Allowed on Parcel for ROW: F Rd

Building	<u>184</u> Sq. Ft.
Free-Standing	<u>288</u> Sq. Ft.
Total Allowed:	<u>288</u> Sq. Ft.

COMMENTS: Remove the 42 sqft sign + install the new 28 sqft sign

NOTE: No sign may exceed 300 square feet. A separate sign clearance is required for each sign. Attach a sketch, to scale, of proposed and existing signage including types, dimensions and lettering. Attach a plot plan, to scale, showing: abutting streets, alleys, easements, driveways, encroachments, property lines, distances from existing buildings to proposed signs and required setbacks. **A SEPARATE PERMIT FROM THE BUILDING DEPARTMENT IS ALSO REQUIRED.**

I hereby attest that the information on this form and the attached sketches are true and accurate.

<u>[Signature]</u>	<u>9-27-05</u>	<u>[Signature]</u>	<u>11-10-05</u>
Applicant's Signature	Date	Community Development Approval	Date

(White: Community Development) (Canary: Applicant) (Pink: Building Dept) (Goldenrod: Code Enforcement)



SIGN CLEARANCE

Community Development Department
250 North 5th Street
Grand Junction CO 81501
(970) 244-1430

Clearance No.	_____
Date Submitted	<u>11-05</u>
Fee \$	<u>5.00</u>
Zone	<u>C-1</u>

TAX SCHEDULE	<u>2945-044-04002</u>	CONTRACTOR	<u>Western New Sign Co Inc</u>
BUSINESS NAME	<u>Bank of The West</u>	LICENSE NO.	<u>20SD455</u>
STREET ADDRESS	<u>2452 F Road 81505</u>	ADDRESS	<u>3183 HALL AVE G.J. 81501</u>
PROPERTY OWNER	<u>2452 Limited Liability Corp</u>	TELEPHONE NO.	<u>523-4045</u>
OWNER ADDRESS	<u>PO Box 55245 G.J. 81505</u>	CONTACT PERSON	<u>John</u>

- | | | |
|-------------------------------------|------------------|--|
| <input checked="" type="checkbox"/> | 1. FLUSH WALL | √2 Square Feet per Linear Foot of Building Facade |
| <input type="checkbox"/> | 2. ROOF | 2 Square Feet per Linear Foot of Building Facade |
| <input type="checkbox"/> | 3. FREE-STANDING | 2 Traffic Lanes - 0.75 Square Feet x Street Frontage |
| | | 4 or more Traffic Lanes - 1.5 Square Feet x Street Frontage |
| <input type="checkbox"/> | 4. PROJECTING | 0.5 Square Feet per each Linear Foot of Building Facade |
| <input type="checkbox"/> | 5. OFF-PREMISE | See #3 Spacing Requirements; Not > 300 Square Feet or < 15 Square Feet |

Externally Illuminated Internally Illuminated Non-Illuminated

(1-5) Area of Proposed Sign: 32 Square Feet 24" X 8' = 16 X 2 FACES = 32

(1,2,4) Building Façade: 92 Linear Feet Building Façade Direction: North South East West

(1-4) Street Frontage: 192 Linear Feet Name of Street: Parking lot ATM

(2-5) Height to Top of Sign: 11' Feet Clearance to Grade: 91 Feet

(5) Distance from all Existing Off-Premise Signs within 600 Feet: NA Feet

EXISTING SIGNAGE/TYPE & SQUARE FOOTAGE:

<u>(A) = 8</u>	<u>(B) = 100</u>	<u>(C) = 100</u>	<u>208</u>	Sq. Ft.
<u>(D) = 28</u>	<u>(E) = 28</u>	<u>Q = 44</u>	<u>100</u>	Sq. Ft.
_____	_____	_____	_____	Sq. Ft.
Total Existing:			_____	Sq. Ft.

FOR OFFICE USE ONLY

Signage Allowed on Parcel for ROW: F Rd	
Building	<u>184</u> Sq. Ft.
Free-Standing	<u>288</u> Sq. Ft.
Total Allowed:	<u>288</u> Sq. Ft.

COMMENTS: Remove panels + install new panels on end of 4 sided ATM unit

NOTE: No sign may exceed 300 square feet. A separate sign clearance is required for each sign. Attach a sketch, to scale, of proposed and existing signage including types, dimensions and lettering. Attach a plot plan, to scale, showing: abutting streets, alleys, easements, driveways, encroachments, property lines, distances from existing buildings to proposed signs and required setbacks. A SEPARATE PERMIT FROM THE BUILDING DEPARTMENT IS ALSO REQUIRED.

I hereby attest that the information on this form and the attached sketches are true and accurate.

<u>[Signature]</u>	<u>9-27-05</u>	<u>[Signature]</u>	<u>11-10-05</u>
Applicant's Signature	Date	Community Development Approval	Date

(White: Community Development) (Canary: Applicant) (Pink: Building Dept) (Goldenrod: Code Enforcement)



SIGN CLEARANCE

Community Development Department
250 North 5th Street
Grand Junction CO 81501
(970) 244-1430

Clearance No.	_____
Date Submitted	11-05
Fee \$	5.00
Zone	C-1

TAX SCHEDULE	2945-044-04002	CONTRACTOR	Western Neon Signs Co. Inc.
BUSINESS NAME	Bank of The West	LICENSE NO.	2050455
STREET ADDRESS	2452 E. Road 81505	ADDRESS	3183 Hall Ave. G.J., Co. 81504
PROPERTY OWNER	_____	TELEPHONE NO.	523-4045
OWNER ADDRESS	2452 Limited Liability Company PO Box 55245 G.J., Co. 81505	CONTACT PERSON	John

- | | |
|---|--|
| <input checked="" type="checkbox"/> 1. FLUSH WALL | <input checked="" type="checkbox"/> 2 Square Feet per Linear Foot of Building Facade |
| <input type="checkbox"/> 2. ROOF | 2 Square Feet per Linear Foot of Building Facade |
| <input type="checkbox"/> 3. FREE-STANDING | 2 Traffic Lanes - 0.75 Square Feet x Street Frontage |
| | 4 or more Traffic Lanes - 1.5 Square Feet x Street Frontage |
| <input type="checkbox"/> 4. PROJECTING | 0.5 Square Feet per each Linear Foot of Building Facade |
| <input type="checkbox"/> 5. OFF-PREMISE | See #3 Spacing Requirements; Not > 300 Square Feet or < 15 Square Feet |

Externally Illuminated Internally Illuminated Non-Illuminated

(1-5) Area of Proposed Sign:	24 ⁴⁴ Square Feet	g Face (A) 24' x 11' = 22 each = 44
(1,2,4) Building Façade:	92' Linear Feet	Building Façade Direction: North <input checked="" type="checkbox"/> South <input type="checkbox"/> East <input type="checkbox"/> West
(1-4) Street Frontage:	192 Linear Feet F-Road	Name of Street: Parking Lot ATM
(2-5) Height to Top of Sign:	11 Feet	Clearance to Grade: 9 Feet
(5) Distance from all Existing Off-Premise Signs within 600 Feet:	NA Feet	

EXISTING SIGNAGE/TYPE & SQUARE FOOTAGE:

(A) = 8	(B) = 100	(C) = 100	208	Sq. Ft.
(D) = 28	(E) = 28		56	Sq. Ft.
Total Existing:				_____ Sq. Ft.

FOR OFFICE USE ONLY

Signage Allowed on Parcel for ROW: F Rd

Building	184	Sq. Ft.
Free-Standing	288	Sq. Ft.
Total Allowed:	288	Sq. Ft.

COMMENTS: Remove panels + install 2 new panels

NOTE: No sign may exceed 300 square feet. A separate sign clearance is required for each sign. Attach a sketch, to scale, of proposed and existing signage including types, dimensions and lettering. Attach a plot plan, to scale, showing: abutting streets, alleys, easements, driveways, encroachments, property lines, distances from existing buildings to proposed signs and required setbacks. A SEPARATE PERMIT FROM THE BUILDING DEPARTMENT IS ALSO REQUIRED.

I hereby attest that the information on this form and the attached sketches are true and accurate.

<u>[Signature]</u>	9-27-05	<u>[Signature]</u>	11-10-05
Applicant's Signature	Date	Community Development Approval	Date

(White: Community Development) (Canary: Applicant) (Pink: Building Dept) (Goldenrod: Code Enforcement)



NORTH ELEVATION

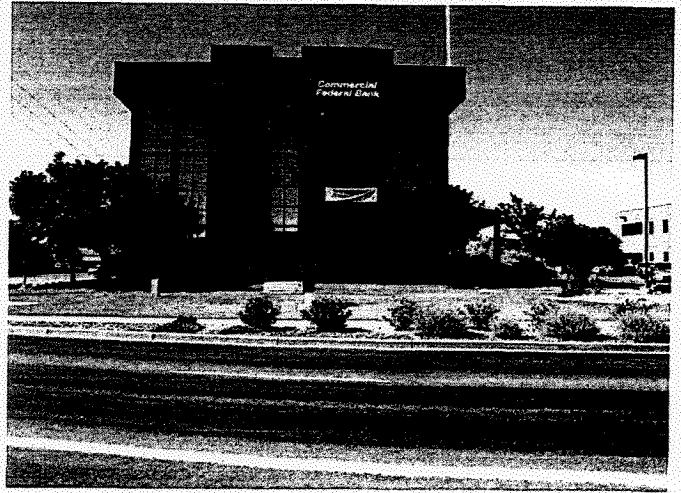

SOUTH ELEVATION

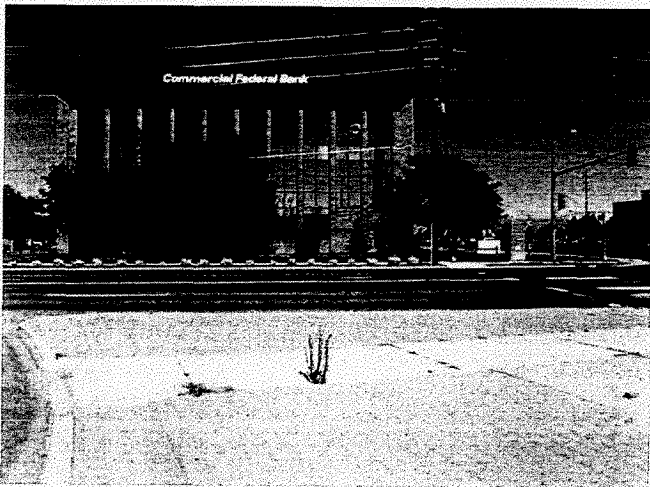

WEST ELEVATION

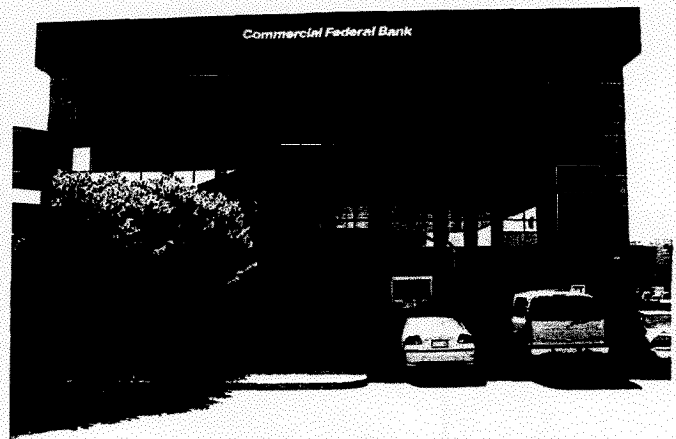

EAST ELEVATION





S.B. 2412 RD.



W.B. PATTERSON RD.



N.B. 2412 RD



E.B. PATTERSON RD.



INTERSECTION VIEW





Photo Number ComCo91-A

Type D/F MONUMENT SIGN

Height 4'-0"

Width 8'-0"

Depth 96 1/4" x 48 1/2" x 16 3/4"

Overall above grade 2" Retainer

- Pylon/Monument Wall Mount
- Directional Vinyl
- Channel letters Other
- Single Face Double Face
- Illuminated Non-Illuminated

Comments _____

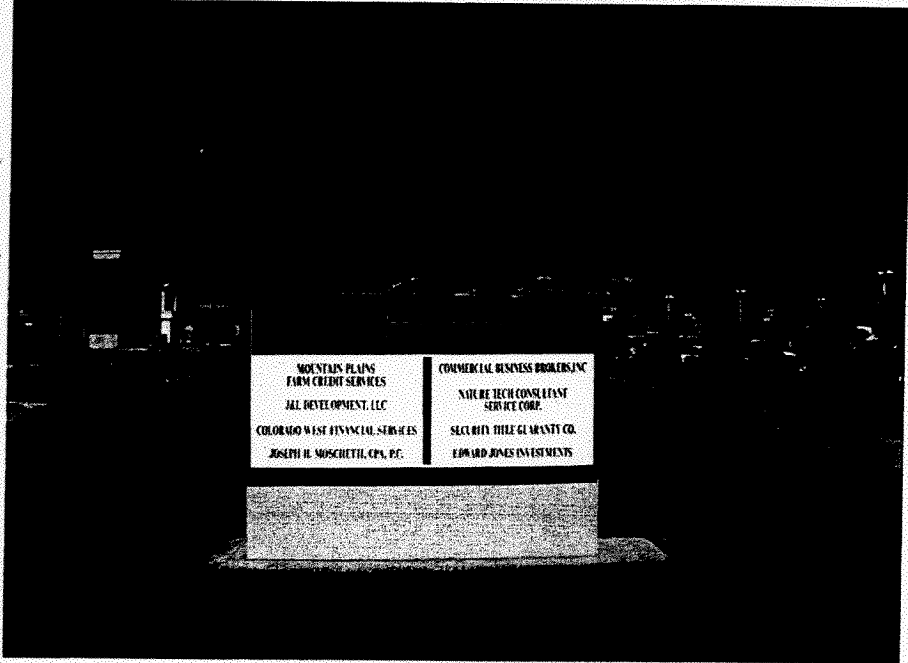

New Signage MFR & INSTALL

(2) REPLACEMENT

VINYL

Comments _____

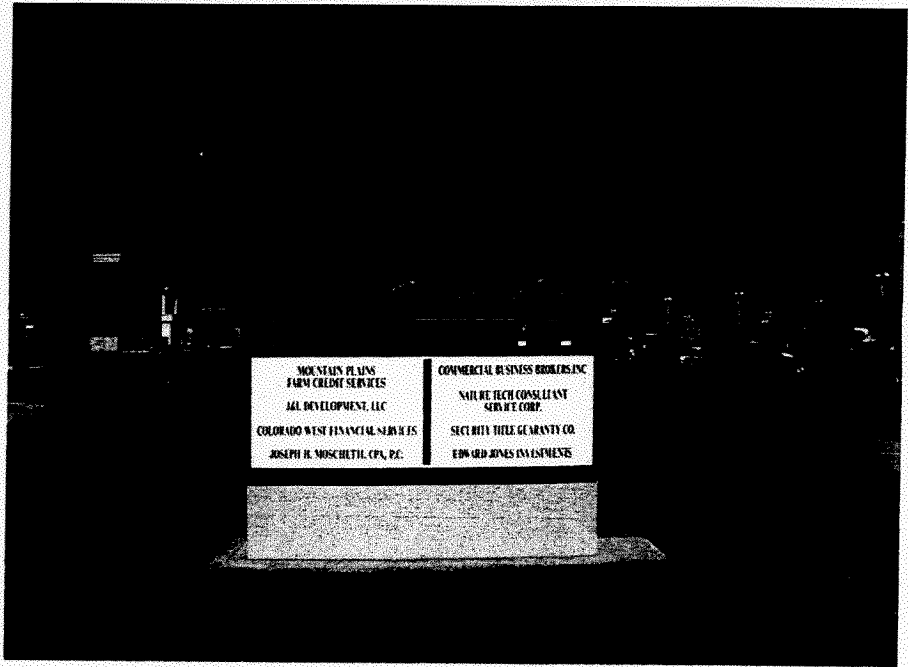



BANK OF THE WEST

revised: 09/21/05

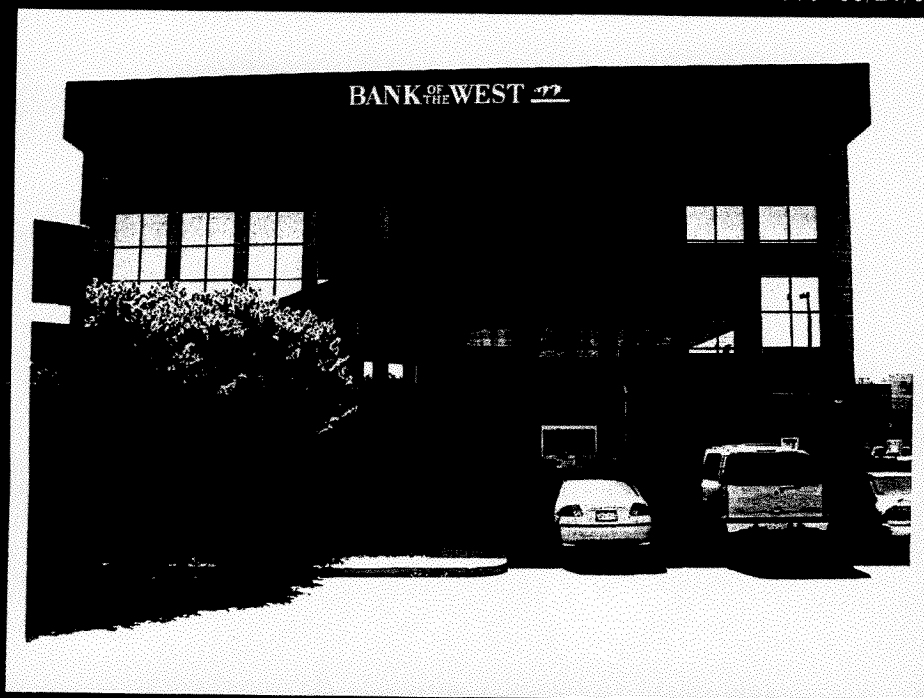

prepared by

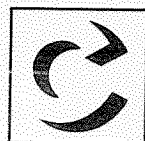

**Chandler
Signs**



13" x 96" Face Size

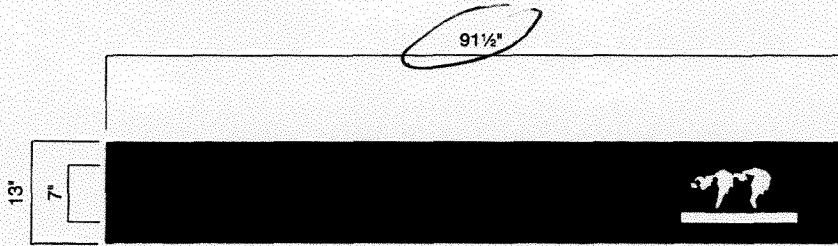

A **REPLACEMENT VINYL DETAIL**

1/2" = 1'-0"

MFR & INSTALL (2) SETS REPLACEMENT VINYL -

FIRST SURFACE VINYL GRAPHICS FOR EXISTING FACES:
7725-0197 NAVY BLUE VINYL BACKGROUND OVERLAY -
LOGO - VT#01964 RED VINYL & #3630-131 GOLD VINYL -
WHITE SHO-THRU COPY -





Photo Number ComCo91-B

Type S/F WALL SIGN

Height 4'-0"

Width 38'-0"

Depth _____

Overall above grade _____

- Pylon/Monument Wall Mount
- Directional Vinyl
- Channel letters Other
- Single Face Double Face
- Illuminated Non-Illuminated

Comments _____



Raceway letters only

New Signage MFR & INSTALL

(1) SET 36" CHANNEL

LETTERS

Comments _____

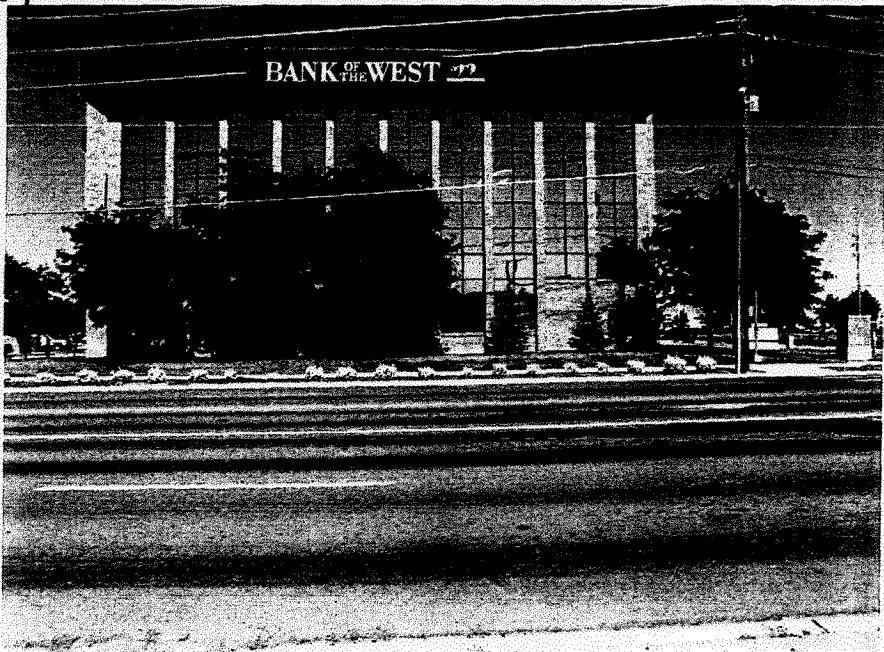

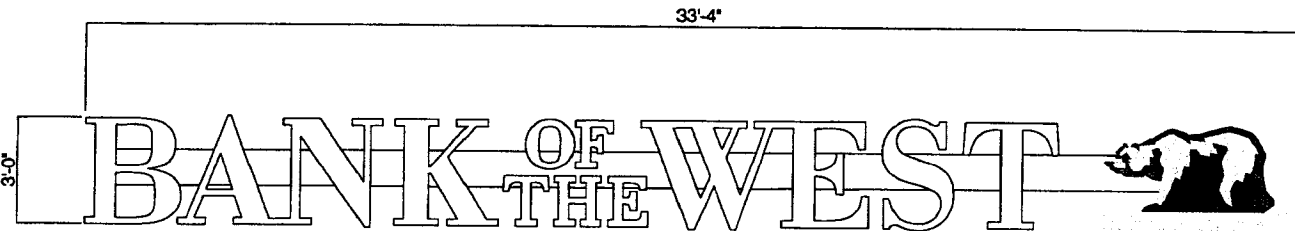

B CHANNEL LETTERS & LOGO LAYOUT
MFR. & INSTALL (1) SET AS SHOWN

3/16" = 1'-0"

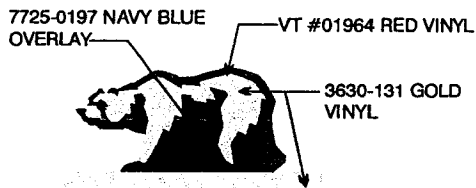

LOGO DETAIL NOT TO SCALE

5" DEEP ALUMINUM CHANNEL
LETTERS PAINTED PMS 540C DARK BLUE -
PAINT INSIDE WITH SPRAYLAT
STAR-BRITE LIGHT ENHANCING PAINT

7328 WHITE PLEXIGLAS FACES
WITH 1" JEWELITE PTM 540C DARK BLUE

EXTRUDED ALUMINUM RACEWAY PTD.
TO MATCH WALL / FASCIA

2" X 2" GALV. PICK-UP ANGLE
(REMOVE AFTER INSTALLATION)

15MM 6500 WHITE 30 m.A. NEON
ILLUMINATION

ELECTROBITS PYROLENE
ELECTRODE INSULATORS

HI-FLEX MAX INTEGRAL SLEEVE GTO
TO TRANSFORMER INSIDE RACEWAY

GLASS NEON TUBE SUPPORTS

1/4" DIA. WEEP HOLES IN LOW POINTS
OF LETTERS AND IN BOTTOM OF RACEWAY

WEATHERPROOF DISCONNECT
SWITCH ON END OF RACEWAY

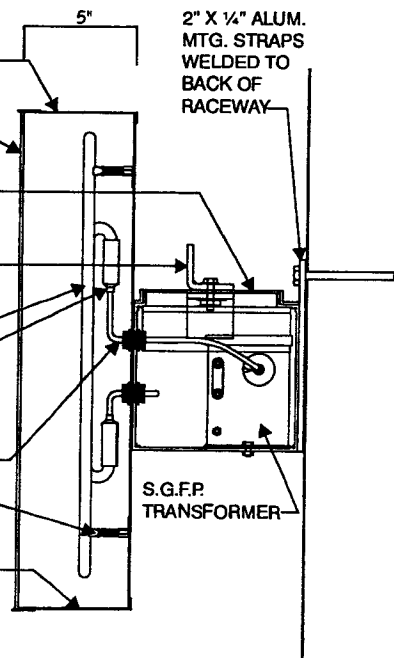

U.L. LABELS REQUIRED
INSTALL IN ACCORDANCE W/
NATIONAL ELECTRIC CODES

B LETTER SECTION
RACEWAY MOUNTED

NOT TO SCALE





Photo Number ComCo91-C

Type S/F WALL SIGN

Height 3'-0"

Width 26'-0"

Depth ~~3' x 23 1/2" SF~~

Overall above grade _____

- | | |
|---|--|
| <input type="checkbox"/> Pylon/Monument | <input checked="" type="checkbox"/> Wall Mount |
| <input type="checkbox"/> Directional | <input type="checkbox"/> Vinyl |
| <input type="checkbox"/> Channel letters | <input type="checkbox"/> Other |
| <input checked="" type="checkbox"/> Single Face | <input type="checkbox"/> Double Face |
| <input checked="" type="checkbox"/> Illuminated | <input type="checkbox"/> Non-Illuminated |

Comments _____



Raceway letters only

New Signage MFR & INSTALL

(1) SET 36" CHANNEL

LETTERS

Comments _____





33'-4"

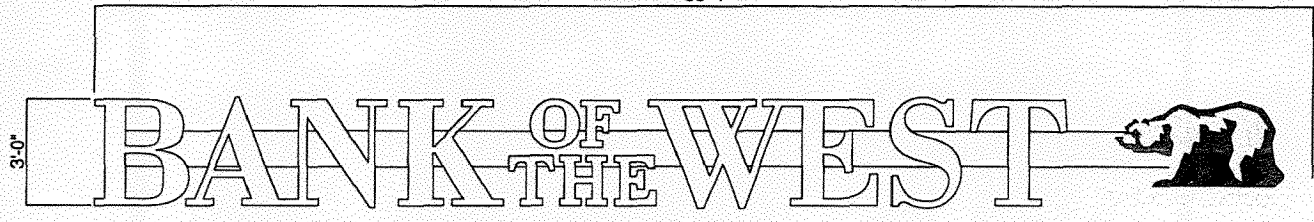

3'-0"

CHANNEL LETTERS & LOGO LAYOUT
MFR. & INSTALL (1) SET AS SHOWN

3/16" = 1'-0"

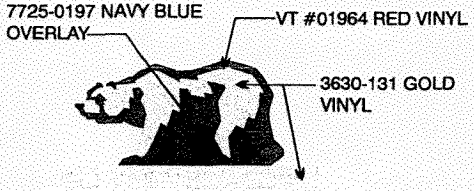

LOGO DETAIL NOT TO SCALE

- 5" DEEP ALUMINUM CHANNEL LETTERS PAINTED PMS 540C DARK BLUE - PAINT INSIDE WITH SPRAYLAT STAR-BRITE LIGHT ENHANCING PAINT
- 7328 WHITE PLEXIGLAS FACES WITH 1" JEWELITE PTM 540C DARK BLUE
- EXTRUDED ALUMINUM RACEWAY PTD. TO MATCH WALL / FASCIA
- 2" X 2" GALV. PICK-UP ANGLE (REMOVE AFTER INSTALLATION)
- 15MM 6500 WHITE 30 m.A. NEON ILLUMINATION
- ELECTROBITS PYROLENE ELECTRODE INSULATORS
- HI-FLEX MAX INTEGRAL SLEEVE GTO TO TRANSFORMER INSIDE RACEWAY
- GLASS NEON TUBE SUPPORTS
- 1/4" DIA. WEEP HOLES IN LOW POINTS OF LETTERS AND IN BOTTOM OF RACEWAY
- WEATHERPROOF DISCONNECT SWITCH ON END OF RACEWAY

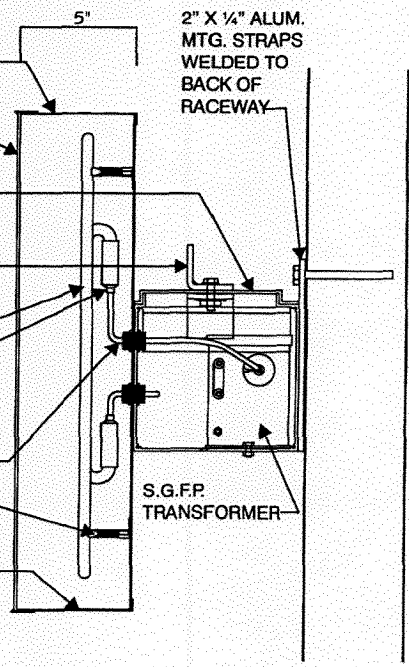

U.L. LABELS REQUIRED
INSTALL IN ACCORDANCE W/
NATIONAL ELECTRIC CODES

LETTER SECTION
RACEWAY MOUNTED

NOT TO SCALE





Photo Number ComCo91-D

Type S/F WALL SIGN

Height 42"

Width 14'-0"

Depth 4' High x 18' Long

Overall above grade _____

- Pylon/Monument Wall Mount
- Directional Vinyl
- Channel letters Other
- Single Face Double Face
- Illuminated Non-Illuminated

Comments _____



Raceway letters only

New Signage MFR & INSTALL

(1) SET 18" CHANNEL

LETTERS

Comments _____

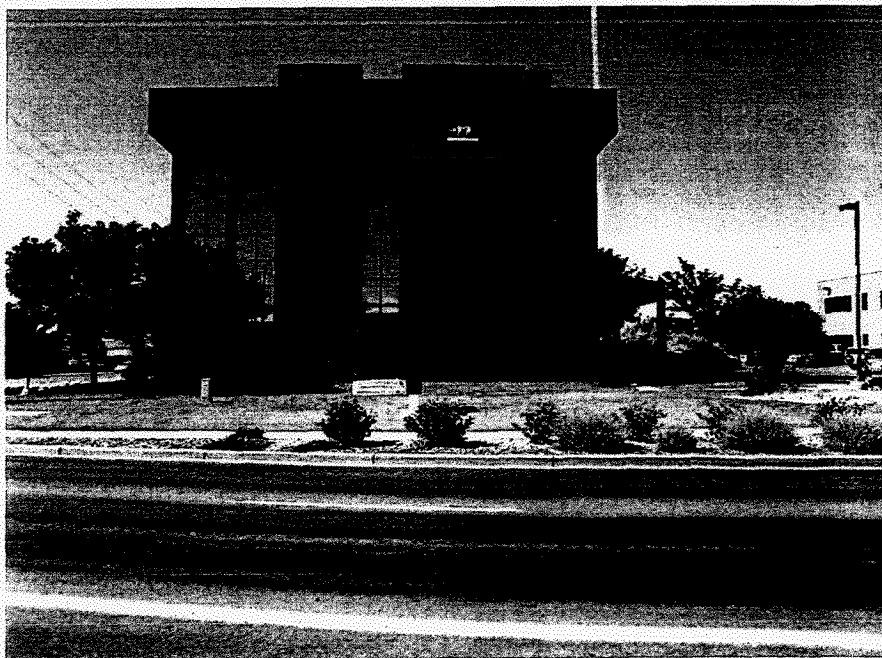

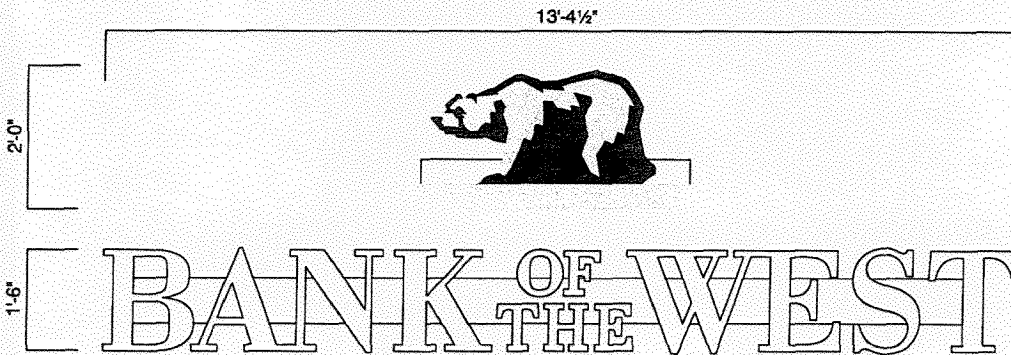

D CHANNEL LETTERS & LOGO LAYOUT
MFR. & INSTALL (1) SET AS SHOWN

3/8" = 1'-0"

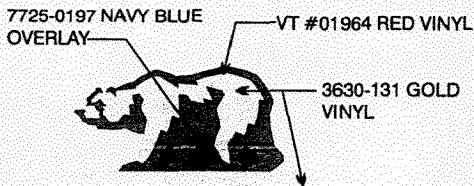

LOGO DETAIL NOT TO SCALE

5" DEEP ALUMINUM CHANNEL LETTERS PAINTED PMS 540C DARK BLUE - PAINT INSIDE WITH SPRAYLAT STAR-BRITE LIGHT ENHANCING PAINT

7328 WHITE PLEXIGLAS FACES WITH 1" JEWELITE PTM 540C DARK BLUE

EXTRUDED ALUMINUM RACEWAY PTD. TO MATCH WALL / FASCIA

2" X 2" GALV. PICK-UP ANGLE (REMOVE AFTER INSTALLATION)

15MM 6500 WHITE 30 m.A. NEON ILLUMINATION

ELECTROBITS PYROLENE ELECTRODE INSULATORS

HI-FLEX MAX INTEGRAL SLEEVE GTO TO TRANSFORMER INSIDE RACEWAY

GLASS NEON TUBE SUPPORTS

1/4" DIA. WEEP HOLES IN LOW POINTS OF LETTERS AND IN BOTTOM OF RACEWAY

WEATHERPROOF DISCONNECT SWITCH ON END OF RACEWAY

U.L. LABELS REQUIRED
INSTALL IN ACCORDANCE W/
NATIONAL ELECTRIC CODES

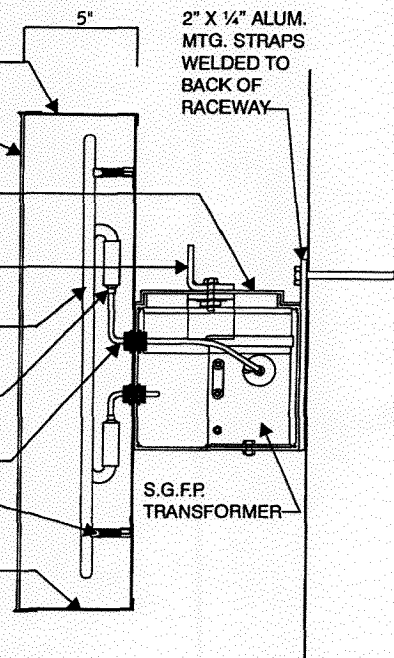

D LETTER SECTION
RACEWAY MOUNTED

NOT TO SCALE



Photo Number ComCo91-E

Type S/F WALL SIGN

Height 42"

Width 14'-0"

Depth ~~17~~ 48" x 18" cabinet

Overall above grade _____

- Pylon/Monument
- Wall Mount
- Directional
- Vinyl
- Channel letters
- Other
- Single Face
- Double Face
- Illuminated
- Non-Illuminated

Comments _____



Raceway letters only

New Signage MFR & INSTALL

(1) SET 18" CHANNEL LETTERS

Comments _____



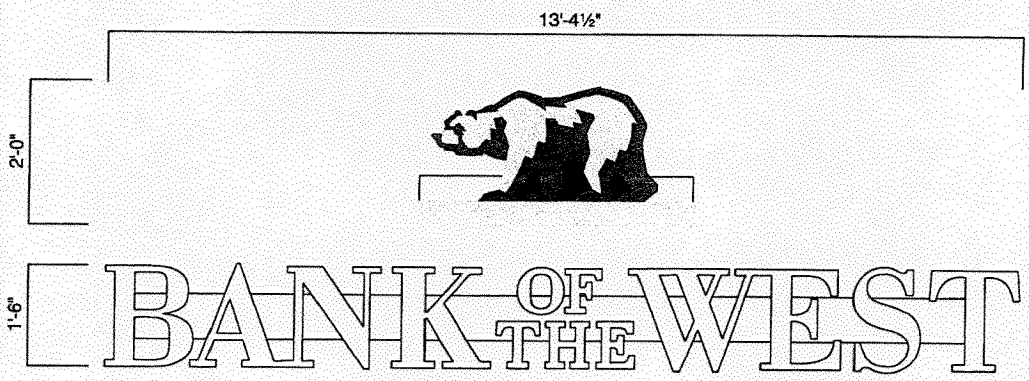

E CHANNEL LETTERS & LOGO LAYOUT
MFR. & INSTALL (1) SET AS SHOWN

3/8" = 1'-0"

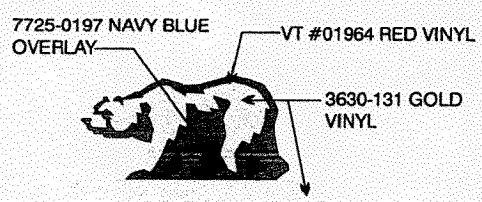

LOGO DETAIL NOT TO SCALE

- 5" DEEP ALUMINUM CHANNEL LETTERS PAINTED PMS 540C DARK BLUE - PAINT INSIDE WITH SPRAYLAT STAR-BRITE LIGHT ENHANCING PAINT
- 7328 WHITE PLEXIGLAS FACES WITH 1" JEWELITE PTM 540C DARK BLUE
- EXTRUDED ALUMINUM RACEWAY PTD. TO MATCH WALL / FASCIA
- 2" X 2" GALV. PICK-UP ANGLE (REMOVE AFTER INSTALLATION)
- 15MM 6500 WHITE 30 m.A. NEON ILLUMINATION
- ELECTROBITS PYROLENE ELECTRODE INSULATORS
- HI-FLEX MAX INTEGRAL SLEEVE GTO TO TRANSFORMER INSIDE RACEWAY
- GLASS NEON TUBE SUPPORTS
- 1/4" DIA. WEEP HOLES IN LOW POINTS OF LETTERS AND IN BOTTOM OF RACEWAY
- WEATHERPROOF DISCONNECT SWITCH ON END OF RACEWAY

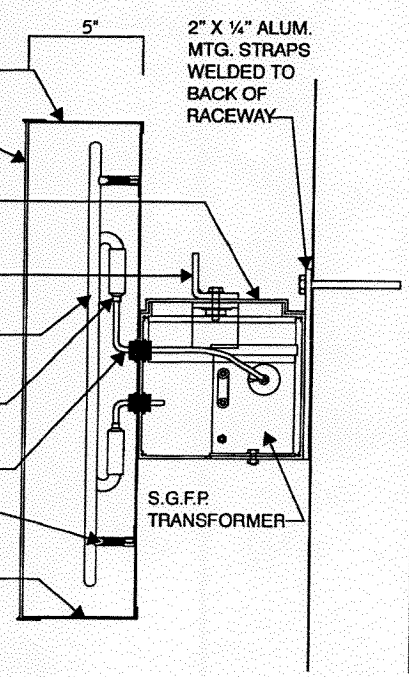

U.L. LABELS REQUIRED
INSTALL IN ACCORDANCE W/
NATIONAL ELECTRIC CODES

E LETTER SECTION
RACEWAY MOUNTED

NOT TO SCALE



OF
H



Photo Number ComCo91-K

Type NON ILLUMINATED DIRECTIONAL

Height 6"

Width 42"

Depth 1 1/2" behind retainers

Overall above grade 129 1/2" X 23 5/8" FACE

- | | |
|---|---|
| <input type="checkbox"/> Pylon/Monument | <input type="checkbox"/> Wall Mount |
| <input type="checkbox"/> Directional | <input type="checkbox"/> Vinyl |
| <input type="checkbox"/> Channel letters | <input type="checkbox"/> Other |
| <input checked="" type="checkbox"/> Single Face | <input type="checkbox"/> Double Face |
| <input type="checkbox"/> Illuminated | <input checked="" type="checkbox"/> Non-Illuminated |

Comments 92 1/2" X 23 5/8" FACE DIMENSIONS

20 3/4" VO
1 1/2" Retainers



New Signage MFR & INSTALL
(1) S/F WALL PANEL

Comments _____

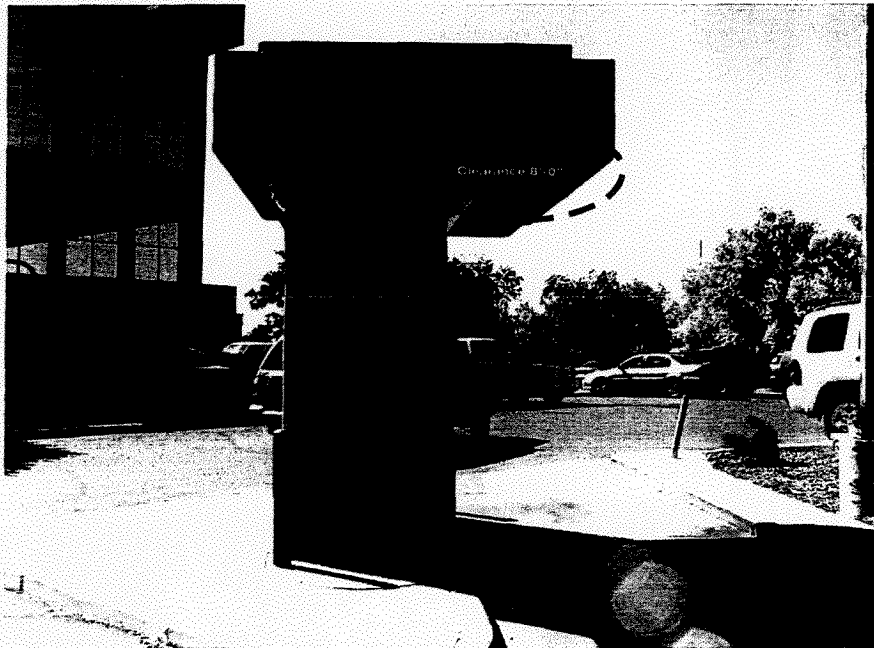

Face Dimensions 129 1/2" x 23 5/8" w/ 1 1/2" Retainers

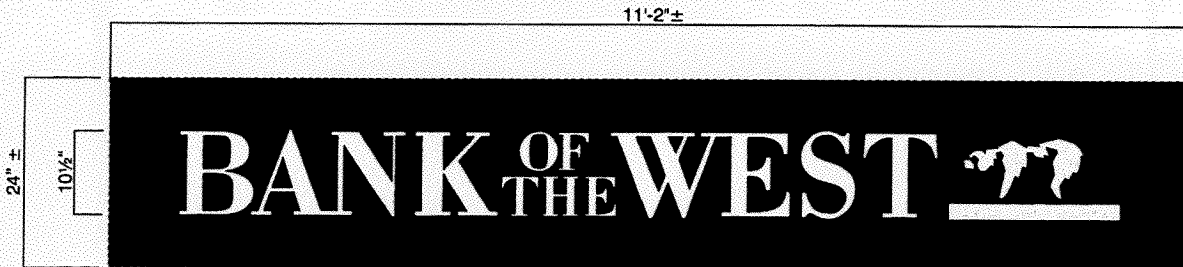

Face Dimensions 92 1/2" x 23 5/8" w/ 1 1/2" Retainers

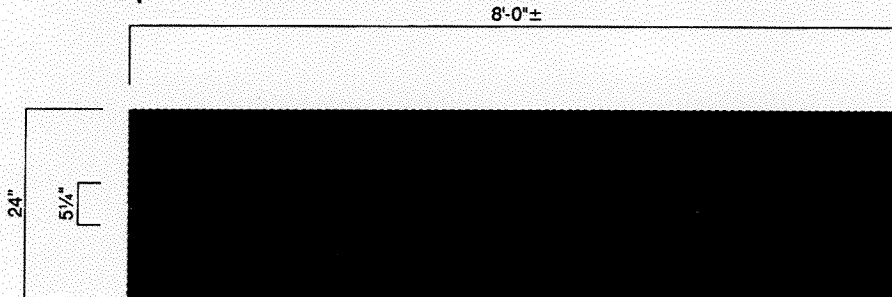

REPLACEMENT FACES DETAIL

1/2" = 1'-0"

MFR & INSTALL (2) LEXAN REPLACEMENT FACES -

7328 WHITE LEXAN FACES W/ FIRST SURFACE VINYL GRAPHICS -
7725-0197 NAVY BLUE VINYL BACKGROUND OVERLAY -
LOGO - VT#01964 RED VINYL & #3630-131 GOLD VINYL -
WHITE SHO-THRU COPY -



Photo Number ComCo91-Q

Type ATM HEADER SIGNS

Height 24"

Width 8"±; 11'-2"±

Depth Same

Overall above grade _____

- | | |
|---|---|
| <input type="checkbox"/> Pylon/Monument | <input type="checkbox"/> Wall Mount |
| <input type="checkbox"/> Directional | <input type="checkbox"/> Vinyl |
| <input type="checkbox"/> Channel letters | <input checked="" type="checkbox"/> Other |
| <input type="checkbox"/> Single Face | <input type="checkbox"/> Double Face |
| <input checked="" type="checkbox"/> Illuminated | <input type="checkbox"/> Non-Illuminated |

Comments _____



Same

New Signage MFR & INSTALL

(4) LEXAN

REPLACEMENT FACE(S)

Comments _____



2412 RD.

235'

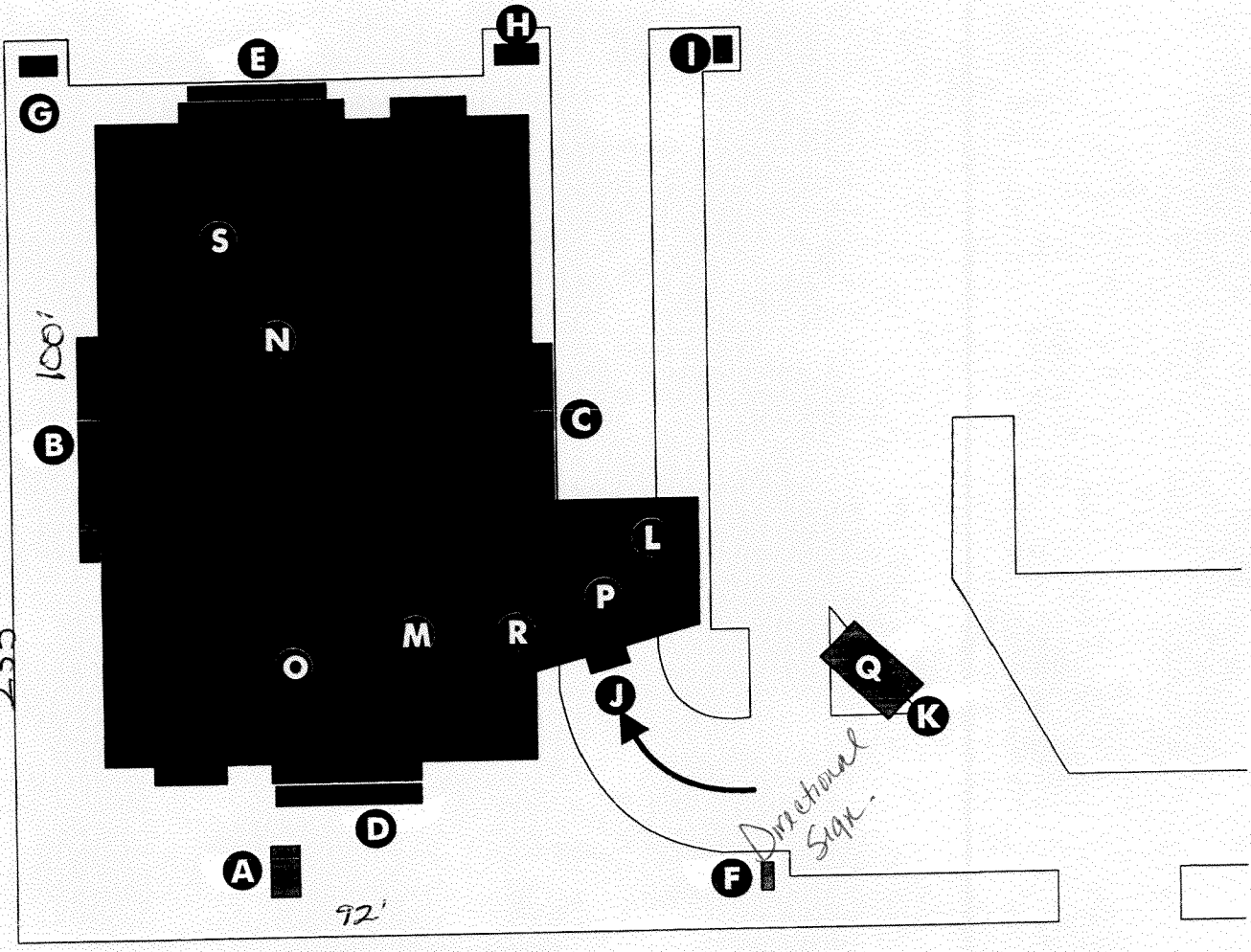

PATTERSON RD.

192'



Site Plan

