



SIGN CLEARANCE

Community Development Department
250 North 5th Street
Grand Junction CO 81501
(970) 244-1430

Clearance No.	_____
Date Submitted	<u>3-17-06</u>
Fee \$	<u>25</u>
Zone	<u>C-2</u>

TAX SCHEDULE	<u>2945-054-08-002</u>	CONTRACTOR	<u>Western Neon Sign Co., Inc</u>
BUSINESS NAME	<u>Starbucks Coffee</u>	LICENSE NO.	<u>2050455</u>
STREET ADDRESS	<u>624 Rae Lynn St. 81505</u>	ADDRESS	<u>3183 Hall Ave, G.J. Co., 81504</u>
PROPERTY OWNER	<u>RMEC Properties LLC</u>	TELEPHONE NO.	<u>523-4043</u>
OWNER ADDRESS	<u>1114 [REDACTED] G.J. Co., 81501</u>	PERSON	<u>John</u>

- | | | |
|-------------------------------------|------------------|--|
| <input checked="" type="checkbox"/> | 1. FLUSH WALL | x 2 Square Feet per Linear Foot of Building Facade |
| <input type="checkbox"/> | 2. ROOF | 2 Square Feet per Linear Foot of Building Facade |
| <input type="checkbox"/> | 3. FREE-STANDING | 2 Traffic Lanes - 0.75 Square Feet x Street Frontage |
| | | 4 or more Traffic Lanes - 1.5 Square Feet x Street Frontage |
| <input type="checkbox"/> | 4. PROJECTING | 0.5 Square Feet per each Linear Foot of Building Facade |
| <input type="checkbox"/> | 5. OFF-PREMISE | See #3 Spacing Requirements; Not > 300 Square Feet or < 15 Square Feet |

Externally Illuminated Internally Illuminated Non-Illuminated

(1 - 5)	Area of Proposed Sign:	<u>12.56</u> Square Feet	<u>KASSANDRA Ave.</u>
(1,2,4)	Building Façade:	<u>32'</u> Linear Feet	Building Façade Direction: <u>North</u> South East West
(1 - 4)	Street Frontage:	<u>242.5</u> Linear Feet	Name of Street: <u>Kassandra Ave.</u>
(2 - 5)	Height to Top of Sign:	<u>18'</u> Feet	Clearance to Grade: <u>14</u> Feet
(5)	Distance from all Existing Off-Premise Signs within 600 Feet:	_____ Feet	

EXISTING SIGNAGE/TYPE & SQUARE FOOTAGE:

<u>0</u>	_____ Sq. Ft.
_____	_____ Sq. Ft.
_____	_____ Sq. Ft.
_____	_____ Sq. Ft.
Total Existing:	_____ Sq. Ft.

FOR OFFICE USE ONLY

Signage Allowed on Parcel for ROW:	
Building	428 <u>380</u> Sq. Ft.
Free-Standing	<u>28</u> Sq. Ft.
Total Allowed:	<u>380</u> Sq. Ft.

COMMENTS: Starbucks Logo Facing North.

NOTE: No sign may exceed 300 square feet. A separate sign clearance is required for each sign. Attach a sketch, to scale, of proposed and existing signage including types, dimensions and lettering. Attach a plot plan, to scale, showing: abutting streets, alleys, easements, driveways, encroachments, property lines, distances from existing buildings to proposed signs and required setbacks. **A SEPARATE PERMIT FROM THE BUILDING DEPARTMENT IS ALSO REQUIRED.**

I hereby attest that the information on this form and the attached sketches are true and accurate.

[Signature] 3-17-06 [Signature] 3-20-06
 Applicant's Signature Date Community Development Approval Date

(White: Community Development) (Canary: Applicant) (Pink: Building Dept) (Goldenrod: Code Enforcement)



SIGN CLEARANCE

Community Development Department
250 North 5th Street
Grand Junction CO 81501
(970) 244-1430

Clearance No. _____
Date Submitted 3-17-06
Fee \$ 5.00
Zone C-2

TAX SCHEDULE 2945-054-08-002 CONTRACTOR Western Neon Sign Co, Inc.
BUSINESS NAME Starbucks Coffee LICENSE NO. 2050455
STREET ADDRESS 624 Rainbow St, 81505 ADDRESS 3183 HALL AVE, G-5, 81504
PROPERTY [REDACTED] LLC TELEPHONE NO. 523-4045
OWNER ADDRESS 1114 North 1st, Unit 201 CONTACT PERSON John
GT 81501

- | | | | |
|-------------------------------------|------------------|-------------------------------------|--|
| <input checked="" type="checkbox"/> | 1. FLUSH WALL | <input checked="" type="checkbox"/> | 2 Square Feet per Linear Foot of Building Facade |
| <input type="checkbox"/> | 2. ROOF | <input type="checkbox"/> | 2 Square Feet per Linear Foot of Building Facade |
| <input type="checkbox"/> | 3. FREE-STANDING | <input type="checkbox"/> | 2 Traffic Lanes - 0.75 Square Feet x Street Frontage |
| <input type="checkbox"/> | 4. PROJECTING | <input type="checkbox"/> | 4 or more Traffic Lanes - 1.5 Square Feet x Street Frontage |
| <input type="checkbox"/> | 5. OFF-PREMISE | <input type="checkbox"/> | 0.5 Square Feet per each Linear Foot of Building Facade |
| | | | See #3 Spacing Requirements; Not > 300 Square Feet or < 15 Square Feet |

Externally Illuminated Internally Illuminated Non-Illuminated

(1 - 5) Area of Proposed Sign: 23.85 Square Feet
(1,2,4) Building Façade: 32' Linear Feet Building Façade Direction: North South East West
(1 - 4) Street Frontage: 272 Linear Feet Name of Street: 24 Road
(2 - 5) Height to Top of Sign: 16' Feet Clearance to Grade: 12' Feet
(5) Distance from all Existing Off-Premise Signs within 600 Feet: _____ Feet

EXISTING SIGNAGE/TYPE & SQUARE FOOTAGE:

<u>Sign (A)</u>	<u>12.56</u> Sq. Ft.
_____	_____ Sq. Ft.
_____	_____ Sq. Ft.
Total Existing:	<u>12.56</u> Sq. Ft.

FOR OFFICE USE ONLY

Signage Allowed on Parcel for ROW:

Building	<u>380</u> Sq. Ft.
Free-Standing	<u>28</u> Sq. Ft.
Total Allowed:	<u>380</u> Sq. Ft.

COMMENTS: _____

NOTE: No sign may exceed 300 square feet. A separate sign clearance is required for each sign. Attach a sketch, to scale, of proposed and existing signage including types, dimensions and lettering. Attach a plot plan, to scale, showing: abutting streets, alleys, easements, driveways, encroachments, property lines, distances from existing buildings to proposed signs and required setbacks. A SEPARATE PERMIT FROM THE BUILDING DEPARTMENT IS ALSO REQUIRED.

I hereby attest that the information on this form and the attached sketches are true and accurate.

[Signature] 3-17-06 [Signature] 3-20-06
Applicant's Signature Date Community Development Approval Date

(White: Community Development) (Canary: Applicant) (Pink: Building Dept) (Goldenrod: Code Enforcement)

Per about Patrons



SIGN CLEARANCE

Community Development Department
250 North 5th Street
Grand Junction CO 81501
(970) 244-1430

Clearance No. _____
 Date Submitted 3-17-06
 Fee \$ 5.-
 Zone C-2

TAX SCHEDULE 2945-054-08-002 CONTRACTOR Western Neon Sign Co, Inc
 BUSINESS NAME Starbucks Coffee LICENSE NO. 2050455
 STREET ADDRESS 624 Rae Lynn St. 81504 ADDRESS 3183 Hall Ave, G.J. 81504
 PROPERTY OWNER REMC LLC TELEPHONE NO. 523-4045
 OWNER ADDRESS 1114 North 1st, Unit 201 CONTACT PERSON John
G-3 CO, 81501

- | | |
|---|--|
| <input checked="" type="checkbox"/> 1. FLUSH WALL | x 2 Square Feet per Linear Foot of Building Facade |
| <input checked="" type="checkbox"/> 2. ROOF | 2 Square Feet per Linear Foot of Building Facade |
| <input type="checkbox"/> 3. FREE-STANDING | 2 Traffic Lanes - 0.75 Square Feet x Street Frontage |
| | 4 or more Traffic Lanes - 1.5 Square Feet x Street Frontage |
| <input type="checkbox"/> 4. PROJECTING | 0.5 Square Feet per each Linear Foot of Building Facade |
| <input type="checkbox"/> 5. OFF-PREMISE | See #3 Spacing Requirements; Not > 300 Square Feet or < 15 Square Feet |

Externally Illuminated Internally Illuminated Non-Illuminated

(1 - 5) Area of Proposed Sign: 23.85 Square Feet
 (1,2,4) Building Façade: 50 Linear Feet Building Façade Direction: North South East West
 (1 - 4) Street Frontage: Rae Lynn 272 Linear Feet Name of Street: Rae Lynn Street
 (2 - 5) Height to Top of Sign: 16' Feet Clearance to Grade: 12 Feet
 (5) Distance from all Existing Off-Premise Signs within 600 Feet: _____ Feet

EXISTING SIGNAGE/TYPE & SQUARE FOOTAGE:

<u>(A)</u>	_____	<u>36.41</u> Sq. Ft.
<u>(B)</u>	_____	_____ Sq. Ft.
	_____	_____ Sq. Ft.
	_____	_____ Sq. Ft.
Total Existing:		<u>36.41</u> Sq. Ft.

FOR OFFICE USE ONLY

Signage Allowed on Parcel for ROW:

Building	<u>380</u>	Sq. Ft.
Free-Standing	<u>28</u>	Sq. Ft.
Total Allowed:	<u>380</u>	Sq. Ft.

COMMENTS: South facing Starbucks sign

NOTE: No sign may exceed 300 square feet. A separate sign clearance is required for each sign. Attach a sketch, to scale, of proposed and existing signage including types, dimensions and lettering. Attach a plot plan, to scale, showing: abutting streets, alleys, easements, driveways, encroachments, property lines, distances from existing buildings to proposed signs and required setbacks. **A SEPARATE PERMIT FROM THE BUILDING DEPARTMENT IS ALSO REQUIRED.**

I hereby attest that the information on this form and the attached sketches are true and accurate.

John 3-16-06 Kathy Valdez 3-20-06
 Applicant's Signature Date Community Development Approval Date

(White: Community Development) (Canary: Applicant) (Pink: Building Dept) (Goldenrod: Code Enforcement)



SIGN CLEARANCE

Community Development Department
250 North 5th Street
Grand Junction CO 81501
(970) 244-1430

Clearance No. _____
Date Submitted 3-17-06
Fee \$ 0
Zone C-2

TAX SCHEDULE 2945-054-08-002 CONTRACTOR Western Sign Center
BUSINESS NAME Starbucks Coffee LICENSE NO. 2050455
STREET ADDRESS 1024 Rae Lynn Dr #1505 ADDRESS 3183 Hall Ave
PROPERTY OWNER RMEC Properties LLC TELEPHONE NO. 523-4045
OWNER ADDRESS 1114 North 1st Unit 201 CONTACT PERSON John

- 1. FLUSH WALL 2 Square Feet per Linear Foot of Building Façade
- 2. ROOF 2 Square Feet per Linear Foot of Building Façade
- 3. FREE-STANDING 2 Traffic Lanes - 0.75 Square Feet x Street Frontage
- Directional Sign 4 or more Traffic Lanes - 1.5 Square Feet x Street Frontage
- 4. PROJECTING 0.5 Square Feet per each Linear Foot of Building Façade
- 5. OFF-PREMISE See #3 Spacing Requirements; Not > 300 Square Feet or < 15 Square Feet

Externally Illuminated Internally Illuminated Non-Illuminated

(1-5) Area of Proposed Sign: 3' Square Feet
(1,2,4) Building Façade: 32' Linear Feet Building Façade Direction: North South East West
(1-4) Street Frontage: 272 Linear Feet Name of Street: 24 Road
(2-5) Height to Top of Sign: 3'10" Feet Clearance to Grade: 0 Feet
(5) Distance from all Existing Off-Premise Signs within 600 Feet: _____ Feet

EXISTING SIGNAGE/TYPE & SQUARE FOOTAGE:

(A) _____ 10.21p Sq. Ft.

Total Existing: 10.21p Sq. Ft.

FOR OFFICE USE ONLY

Signage Allowed on Parcel for ROW:

Building 380 Sq. Ft.
Free-Standing 28 Sq. Ft.
Total Allowed: 380 Sq. Ft.

COMMENTS: Directional sign on the East side of building.

NOTE: No sign may exceed 300 square feet. A separate sign clearance is required for each sign. Attach a sketch, to scale, of proposed and existing signage including types, dimensions and lettering. Attach a plot plan, to scale, showing: abutting streets, alleys, easements, driveways, encroachments, property lines, distances from existing buildings to proposed signs and required setbacks. A SEPARATE PERMIT FROM THE BUILDING DEPARTMENT IS ALSO REQUIRED.

I hereby attest that the information on this form and the attached sketches are true and accurate.

[Signature] 04/04/06 Raylen Henderson 4-4-06
Applicant's Signature Date Community Development Approval Date

(White: Community Development) (Canary: Applicant) (Pink: Building Dept) (Goldenrod: Code Enforcement)

(E)



SIGN CLEARANCE

Community Development Department
250 North 5th Street
Grand Junction CO 81501
(970) 244-1430

Clearance No.	_____
Date Submitted	<u>3-17-06</u>
Fee \$	100.00
Zone	<u>C-2</u>

TAX SCHEDULE	<u>2945-054-08-002</u>	CONTRACTOR	<u>Western Neon Sign Co. Inc</u>
BUSINESS NAME	<u>Starbucks Coffee</u>	LICENSE NO.	<u>2050455</u>
STREET ADDRESS	<u>624 Rae Lynn St, 81503</u>	ADDRESS	<u>3183 Hall Ave, G.J., 81504</u>
PROPERTY OWNER	<u>RMEC Properties LLC</u>	TELEPHONE NO.	<u>523-4045</u>
OWNER ADDRESS	<u>1114 North 1st unit 201, 81501</u>	CONTACT PERSON	<u>John</u>

- | | | |
|-------------------------------------|-------------------------|--|
| <input type="checkbox"/> | 1. FLUSH WALL | 2 Square Feet per Linear Foot of Building Facade |
| <input type="checkbox"/> | 2. ROOF | 2 Square Feet per Linear Foot of Building Facade |
| <input type="checkbox"/> | 3. FREE-STANDING | 2 Traffic Lanes - 0.75 Square Feet x Street Frontage |
| <input checked="" type="checkbox"/> | <u>Directional Sign</u> | 4 or more Traffic Lanes - 1.5 Square Feet x Street Frontage |
| <input type="checkbox"/> | 4. PROJECTING | 0.5 Square Feet per each Linear Foot of Building Facade |
| <input type="checkbox"/> | 5. OFF-PREMISE | See #3 Spacing Requirements; Not > 300 Square Feet or < 15 Square Feet |

Externally Illuminated Internally Illuminated Non-Illuminated

(1 - 5) Area of Proposed Sign: 2.11 ~~1.75~~ Square Feet

(1,2,4) Building Façade: 32 Linear Feet Building Façade Direction: North South East West

(1 - 4) Street Frontage: 272 Linear Feet Name of Street: Rae Lynn Street

(2 - 5) Height to Top of Sign: 3'10" Feet Clearance to Grade: 0 Feet

(5) Distance from all Existing Off-Premise Signs within 600 Feet: _____ Feet

EXISTING SIGNAGE/TYPE & SQUARE FOOTAGE:

(A)(B)(C)(D) _____ 68.01 Sq. Ft.

_____ Sq. Ft.

_____ Sq. Ft.

Total Existing: _____ Sq. Ft.

FOR OFFICE USE ONLY

Signage Allowed on Parcel for ROW:

Building _____ Sq. Ft.

Free-Standing _____ Sq. Ft.

Total Allowed: _____ Sq. Ft.

COMMENTS: Directional sign on the west side of lot.

NOTE: No sign may exceed 300 square feet. A separate sign clearance is required for each sign. Attach a sketch, to scale, of proposed and existing signage including types, dimensions and lettering. Attach a plot plan, to scale, showing: abutting streets, alleys, easements, driveways, encroachments, property lines, distances from existing buildings to proposed signs and required setbacks. A SEPARATE PERMIT FROM THE BUILDING DEPARTMENT IS ALSO REQUIRED.

I hereby attest that the information on this form and the attached sketches are true and accurate.

John _____ 3-17-06 _____ Kathy Valdez _____ 3-20-06

Applicant's Signature Date Community Development Approval Date

(White: Community Development) (Canary: Applicant) (Pink: Building Dept) (Goldenrod: Code Enforcement)

OK per Scott Peterson

F



SIGN CLEARANCE

Community Development Department
250 North 5th Street
Grand Junction CO 81501
(970) 244-1430

Clearance No. _____
Date Submitted 3-17-06
Fee \$ 5.-
Zone C-2

TAX SCHEDULE 2945-054-08-002 CONTRACTOR Western Neon Sign Co. Inc.
BUSINESS NAME Starbucks Coffee LICENSE NO. 20 50 455
STREET ADDRESS 624 Rae Lynn St, 81505 ADDRESS 3183 Hall Ave, 81504
PROPERTY OWNER RMEC Properties LLC TELEPHONE NO. 523-4045
OWNER ADDRESS 1114 North 1st, unit 201, Grand Junction, CO, 81501 CONTACT PERSON John

- 1. FLUSH WALL 2 Square Feet per Linear Foot of Building Facade
- 2. ROOF 2 Square Feet per Linear Foot of Building Facade
- 3. FREE-STANDING 2 Traffic Lanes - 0.75 Square Feet x Street Frontage
- Directional 4 or more Traffic Lanes - 1.5 Square Feet x Street Frontage
- 4. PROJECTING 0.5 Square Feet per each Linear Foot of Building Facade
- 5. OFF-PREMISE See #3 Spacing Requirements; Not > 300 Square Feet or < 15 Square Feet

Externally Illuminated Internally Illuminated Non-Illuminated

(1 - 5) Area of Proposed Sign: ~~275~~ 21 Square Feet
(1,2,4) Building Façade: 50 Linear Feet Building Façade Direction: North South East West
(1 - 4) Street Frontage: 242.5 Linear Feet Name of Street: Kassandra Ave
(2 - 5) Height to Top of Sign: 3'10" Feet Clearance to Grade: 0 Feet
(5) Distance from all Existing Off-Premise Signs within 600 Feet: _____ Feet

EXISTING SIGNAGE/TYPE & SQUARE FOOTAGE:

<u>(A)</u>	<u>(B)</u>	<u>(C)</u>	<u>(D)</u>	<u>(E)</u>	_____	_____
_____	_____	_____	_____	_____	_____	<u>75.76</u> Sq. Ft.
_____	_____	_____	_____	_____	_____	_____ Sq. Ft.
_____	_____	_____	_____	_____	_____	_____ Sq. Ft.
Total Existing:						_____ Sq. Ft.

FOR OFFICE USE ONLY

Signage Allowed on Parcel for ROW:

Building	_____	Sq. Ft.
Free-Standing	_____	Sq. Ft.
Total Allowed:	_____	Sq. Ft.

COMMENTS: Directional Sign on the north entrance of lot.

NOTE: No sign may exceed 300 square feet. A separate sign clearance is required for each sign. Attach a sketch, to scale, of proposed and existing signage including types, dimensions and lettering. Attach a plot plan, to scale, showing: abutting streets, alleys, easements, driveways, encroachments, property lines, distances from existing buildings to proposed signs and required setbacks. **A SEPARATE PERMIT FROM THE BUILDING DEPARTMENT IS ALSO REQUIRED.**

I hereby attest that the information on this form and the attached sketches are true and accurate.

[Signature] 3-17-06 [Signature] 3-20-06
Applicant's Signature Date Community Development Approval Date

(White: Community Development) (Canary: Applicant) (Pink: Building Dept) (Goldenrod: Code Enforcement)



SIGN CLEARANCE

Community Development Department
250 North 5th Street
Grand Junction CO 81501
(970) 244-1430

Clearance No. _____
Date Submitted 3-17-06
Fee \$ 5.00
Zone C-2

TAX SCHEDULE 2945-054-08-002 CONTRACTOR Western Neon Sign Co., Inc.
BUSINESS NAME Starbucks Coffee LICENSE NO. 2050455
STREET ADDRESS 624 Rae Lynn St. 81505 ADDRESS 3183 HALL AVE 81504
PROPERTY OWNER RMEC Properties LLC TELEPHONE NO. 523-4045
OWNER ADDRESS 1114 North 1st unit 201 CONTACT PERSON John
6-51 Co. 81501

- 1. FLUSH WALL 2 Square Feet per Linear Foot of Building Facade
- 2. ROOF 2 Square Feet per Linear Foot of Building Facade
- 3. FREE-STANDING 2 Traffic Lanes - 0.75 Square Feet x Street Frontage
4 or more Traffic Lanes - 1.5 Square Feet x Street Frontage
- 4. PROJECTING 0.5 Square Feet per each Linear Foot of Building Facade
- 5. OFF-PREMISE See #3 Spacing Requirements; Not > 300 Square Feet or < 15 Square Feet

Externally Illuminated Internally Illuminated Non-Illuminated

(1 - 5) Area of Proposed Sign: 31.75 Square Feet
(1,2,4) Building Façade: 32 Linear Feet Building Façade Direction: North South East West
(1 - 4) Street Frontage: 272 Linear Feet Name of Street: Rae Lynn Street
(2 - 5) Height to Top of Sign: 5'6" Feet Clearance to Grade: 2' Feet
(5) Distance from all Existing Off-Premise Signs within 600 Feet: _____ Feet

EXISTING SIGNAGE/TYPE & SQUARE FOOTAGE:

(A) (B) (C) (D) (E) (F) _____ 107.5 Sq. Ft.

Total Existing: _____ Sq. Ft.

FOR OFFICE USE ONLY

Signage Allowed on Parcel for ROW:

Building _____ Sq. Ft.
Free-Standing _____ Sq. Ft.
Total Allowed: _____ Sq. Ft.

COMMENTS: Drive thru menu board on west side of the building

NOTE: No sign may exceed 300 square feet. A separate sign clearance is required for each sign. Attach a sketch, to scale, of proposed and existing signage including types, dimensions and lettering. Attach a plot plan, to scale, showing: abutting streets, alleys, easements, driveways, encroachments, property lines, distances from existing buildings to proposed signs and required setbacks. A SEPARATE PERMIT FROM THE BUILDING DEPARTMENT IS ALSO REQUIRED.

I hereby attest that the information on this form and the attached sketches are true and accurate.

[Signature] 3-17-06 [Signature] 3-28-06
Applicant's Signature Date Community Development Approval Date

(White: Community Development) (Canary: Applicant) (Pink: Building Dept) (Goldenrod: Code Enforcement)



SIGN CLEARANCE

Community Development Department
250 North 5th Street
Grand Junction CO 81501
(970) 244-1430

Clearance No.	_____
Date Submitted	<u>4-4-06</u>
Fee \$	<u>5.00</u>
Zone	<u>C-2</u>

TAX SCHEDULE	<u>2945-054-08-002</u>	CONTRACTOR	<u>Western Neon Sign Co. Inc</u>
BUSINESS NAME	<u>Starbucks Coffee</u>	LICENSE NO.	<u>2050455</u>
STREET ADDRESS	<u>624 Raelynn St, 81505</u>	ADDRESS	<u>3183 HALL AVE G.J. 81504</u>
PROPERTY OWNER	<u>RMEC Properties LLC</u>	TELEPHONE NO.	<u>523-4045</u>
OWNER ADDRESS	<u>1114 North 1st Unit 201 G.J. 81501</u>	CONTACT PERSON	<u>John</u>

- | | |
|---|--|
| <input checked="" type="checkbox"/> 1. FLUSH WALL | <input checked="" type="checkbox"/> 2 Square Feet per Linear Foot of Building Facade |
| <input type="checkbox"/> 2. ROOF | 2 Square Feet per Linear Foot of Building Facade |
| <input type="checkbox"/> 3. FREE-STANDING | 2 Traffic Lanes - 0.75 Square Feet x Street Frontage |
| | 4 or more Traffic Lanes - 1.5 Square Feet x Street Frontage |
| <input type="checkbox"/> 4. PROJECTING | 0.5 Square Feet per each Linear Foot of Building Facade |
| <input type="checkbox"/> 5. OFF-PREMISE | See #3 Spacing Requirements; Not > 300 Square Feet or < 15 Square Feet |

Externally Illuminated Internally Illuminated Non-Illuminated

(1 - 5) Area of Proposed Sign: 14'± Square Feet
 (1,2,4) Building Façade: 32' Linear Feet
 (1 - 4) Street Frontage: 24 Road Linear Feet
 (2 - 5) Height to Top of Sign: 18' Feet Clearance to Grade: 14' Feet
 (5) Distance from all Existing Off-Premise Signs within 600 Feet: NA Feet

EXISTING SIGNAGE/TYPE:	
_____	_____ Sq. Ft.
_____	_____ Sq. Ft.
_____	_____ Sq. Ft.
_____	_____ Sq. Ft.
Total Existing:	_____ Sq. Ft.

● FOR OFFICE USE ONLY ●	
Signage Allowed on Parcel:	
Building	<u>380</u> Sq. Ft.
Free-Standing	<u>28</u> Sq. Ft.
Total Allowed:	<u>380</u> Sq. Ft.

COMMENTS: Add 2 more "Round Starbucks" logo to the East Building side on the south facing angle.

NOTE: No sign may exceed 300 square feet. A separate sign clearance is required for each sign. Attach a sketch, to scale, of proposed and existing signage including types, dimensions and lettering. Attach a plot plan, to scale, showing: abutting streets, alleys, easements, driveways, encroachments, property lines, distances from existing buildings to proposed signs and required setbacks. **A SEPARATE PERMIT FROM THE BUILDING DEPARTMENT IS ALSO REQUIRED.**

I hereby attest that the information on this form and the attached sketches are true and accurate.

John 4-4-06 Gayleen Henderson 4-4-06
 Applicant's Signature Date Community Development Approval Date

(White: Community Development) (Canary: Applicant) (Pink: Building Dept) (Goldenrod: Code Enforcement)

242.5

KASSANDRA AVENUE

RAE LYNN STREET

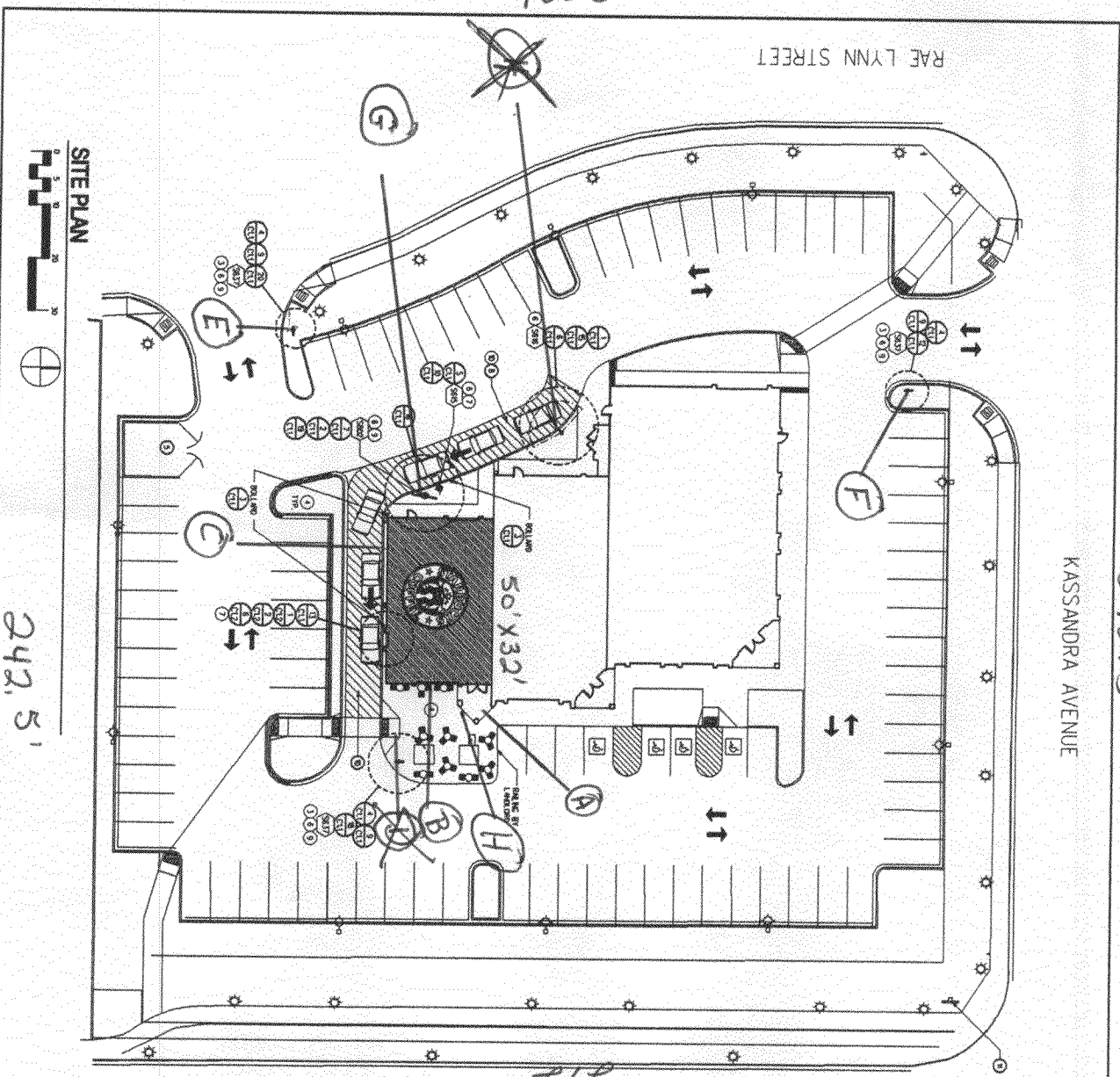

SITE PLAN



242.5'

Building is 50' x 32'

SIGNAGE SCHEDULE	
ITEM	DESCRIPTION
1	48" SINGLE COLUMN
2	48" SINGLE COLUMN
3	48" SINGLE COLUMN
4	48" SINGLE COLUMN
5	48" SINGLE COLUMN
6	48" SINGLE COLUMN
7	48" SINGLE COLUMN
8	48" SINGLE COLUMN
9	48" SINGLE COLUMN
10	48" SINGLE COLUMN
11	48" SINGLE COLUMN
12	48" SINGLE COLUMN
13	48" SINGLE COLUMN
14	48" SINGLE COLUMN
15	48" SINGLE COLUMN
16	48" SINGLE COLUMN
17	48" SINGLE COLUMN
18	48" SINGLE COLUMN
19	48" SINGLE COLUMN
20	48" SINGLE COLUMN
21	48" SINGLE COLUMN
22	48" SINGLE COLUMN
23	48" SINGLE COLUMN
24	48" SINGLE COLUMN
25	48" SINGLE COLUMN
26	48" SINGLE COLUMN
27	48" SINGLE COLUMN
28	48" SINGLE COLUMN
29	48" SINGLE COLUMN
30	48" SINGLE COLUMN
31	48" SINGLE COLUMN
32	48" SINGLE COLUMN
33	48" SINGLE COLUMN
34	48" SINGLE COLUMN
35	48" SINGLE COLUMN
36	48" SINGLE COLUMN
37	48" SINGLE COLUMN
38	48" SINGLE COLUMN
39	48" SINGLE COLUMN
40	48" SINGLE COLUMN
41	48" SINGLE COLUMN
42	48" SINGLE COLUMN
43	48" SINGLE COLUMN
44	48" SINGLE COLUMN
45	48" SINGLE COLUMN
46	48" SINGLE COLUMN
47	48" SINGLE COLUMN
48	48" SINGLE COLUMN
49	48" SINGLE COLUMN
50	48" SINGLE COLUMN

24 ROAD

ALL SIGNAGE UNDER SEPARATE PERMIT

NOTES:

1. REFER TO SHEET 242 FOR SIGNAGE SCHEDULE AND SIGNAGE SCHEDULE FOR ELECTRICAL REQUIREMENTS.
2. SEE ALL SIGNAGE SCHEDULE FOR ALL SIGNAGE NOTES TO BE ADDED TO SHEET 242.
3. SIGNAGE TO BE LOCATED TO BE ON THE EXTERIOR OF THE BUILDING.
4. SIGNAGE TO BE LOCATED TO BE ON THE EXTERIOR OF THE BUILDING.
5. SIGNAGE TO BE LOCATED TO BE ON THE EXTERIOR OF THE BUILDING.
6. SIGNAGE TO BE LOCATED TO BE ON THE EXTERIOR OF THE BUILDING.
7. SIGNAGE TO BE LOCATED TO BE ON THE EXTERIOR OF THE BUILDING.
8. SIGNAGE TO BE LOCATED TO BE ON THE EXTERIOR OF THE BUILDING.
9. SIGNAGE TO BE LOCATED TO BE ON THE EXTERIOR OF THE BUILDING.
10. SIGNAGE TO BE LOCATED TO BE ON THE EXTERIOR OF THE BUILDING.
11. SIGNAGE TO BE LOCATED TO BE ON THE EXTERIOR OF THE BUILDING.
12. SIGNAGE TO BE LOCATED TO BE ON THE EXTERIOR OF THE BUILDING.
13. SIGNAGE TO BE LOCATED TO BE ON THE EXTERIOR OF THE BUILDING.
14. SIGNAGE TO BE LOCATED TO BE ON THE EXTERIOR OF THE BUILDING.
15. SIGNAGE TO BE LOCATED TO BE ON THE EXTERIOR OF THE BUILDING.
16. SIGNAGE TO BE LOCATED TO BE ON THE EXTERIOR OF THE BUILDING.
17. SIGNAGE TO BE LOCATED TO BE ON THE EXTERIOR OF THE BUILDING.
18. SIGNAGE TO BE LOCATED TO BE ON THE EXTERIOR OF THE BUILDING.
19. SIGNAGE TO BE LOCATED TO BE ON THE EXTERIOR OF THE BUILDING.
20. SIGNAGE TO BE LOCATED TO BE ON THE EXTERIOR OF THE BUILDING.
21. SIGNAGE TO BE LOCATED TO BE ON THE EXTERIOR OF THE BUILDING.
22. SIGNAGE TO BE LOCATED TO BE ON THE EXTERIOR OF THE BUILDING.
23. SIGNAGE TO BE LOCATED TO BE ON THE EXTERIOR OF THE BUILDING.
24. SIGNAGE TO BE LOCATED TO BE ON THE EXTERIOR OF THE BUILDING.
25. SIGNAGE TO BE LOCATED TO BE ON THE EXTERIOR OF THE BUILDING.
26. SIGNAGE TO BE LOCATED TO BE ON THE EXTERIOR OF THE BUILDING.
27. SIGNAGE TO BE LOCATED TO BE ON THE EXTERIOR OF THE BUILDING.
28. SIGNAGE TO BE LOCATED TO BE ON THE EXTERIOR OF THE BUILDING.
29. SIGNAGE TO BE LOCATED TO BE ON THE EXTERIOR OF THE BUILDING.
30. SIGNAGE TO BE LOCATED TO BE ON THE EXTERIOR OF THE BUILDING.
31. SIGNAGE TO BE LOCATED TO BE ON THE EXTERIOR OF THE BUILDING.
32. SIGNAGE TO BE LOCATED TO BE ON THE EXTERIOR OF THE BUILDING.
33. SIGNAGE TO BE LOCATED TO BE ON THE EXTERIOR OF THE BUILDING.
34. SIGNAGE TO BE LOCATED TO BE ON THE EXTERIOR OF THE BUILDING.
35. SIGNAGE TO BE LOCATED TO BE ON THE EXTERIOR OF THE BUILDING.
36. SIGNAGE TO BE LOCATED TO BE ON THE EXTERIOR OF THE BUILDING.
37. SIGNAGE TO BE LOCATED TO BE ON THE EXTERIOR OF THE BUILDING.
38. SIGNAGE TO BE LOCATED TO BE ON THE EXTERIOR OF THE BUILDING.
39. SIGNAGE TO BE LOCATED TO BE ON THE EXTERIOR OF THE BUILDING.
40. SIGNAGE TO BE LOCATED TO BE ON THE EXTERIOR OF THE BUILDING.
41. SIGNAGE TO BE LOCATED TO BE ON THE EXTERIOR OF THE BUILDING.
42. SIGNAGE TO BE LOCATED TO BE ON THE EXTERIOR OF THE BUILDING.
43. SIGNAGE TO BE LOCATED TO BE ON THE EXTERIOR OF THE BUILDING.
44. SIGNAGE TO BE LOCATED TO BE ON THE EXTERIOR OF THE BUILDING.
45. SIGNAGE TO BE LOCATED TO BE ON THE EXTERIOR OF THE BUILDING.
46. SIGNAGE TO BE LOCATED TO BE ON THE EXTERIOR OF THE BUILDING.
47. SIGNAGE TO BE LOCATED TO BE ON THE EXTERIOR OF THE BUILDING.
48. SIGNAGE TO BE LOCATED TO BE ON THE EXTERIOR OF THE BUILDING.
49. SIGNAGE TO BE LOCATED TO BE ON THE EXTERIOR OF THE BUILDING.
50. SIGNAGE TO BE LOCATED TO BE ON THE EXTERIOR OF THE BUILDING.

SCALE: 1/4" = 1'-0"

DO NOT SCALE DRAWING

SHEET NUMBER: C1

STARBUCKS COFFEE

24 RD & KASSANDRA

824 RAE LYNN ST

GRAND JUNCTION, CO. 81505

PROJECT # 23910

OWNER: 888-888-1111

ARCHITECT: CLASSICO

DESIGNER: CLASSICO

DATE: 01/15/2010

CHECKER: YVESI HONG

DATE: 01/15/2010

STARBUCKS COFFEE

ARCHITECT OF RECORD

**SINGLE FACE ILLUMINATED WALL MOUNT LOGO DISK SPECIFICATION
TAG # S353 / 48"(1219mm) LOGO**

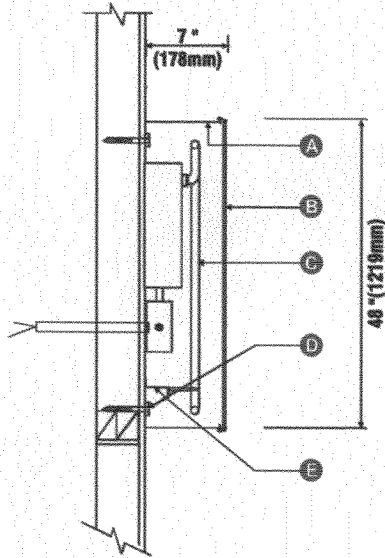

Section View
Scale: n.t.s.



Front View (48"/1219mm)
scale 1/2" = 1'-0"

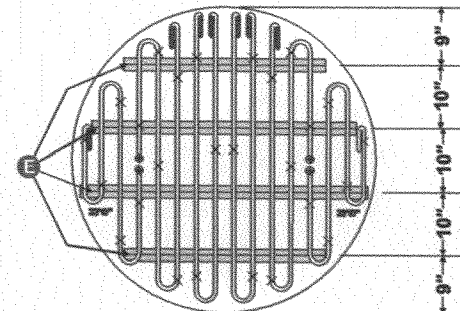

Open View Neon Layout (48"/1219mm)
15 mm neon

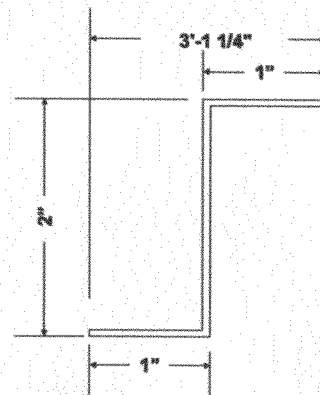

Z-Bracket
Scale: n.t.s.

Tag	Size	Sq.Ft.	Sq.M.	Volts	Amps	Trans.Size
S353	48" (1219mm)	12.56	1.17	120	1.8	SS 935 EK (2)

- SPECIFICATIONS:**
- A** 48"(1219mm) Single faced internally illuminated wall mount logo disk. Cabinet to be 7"(178mm) deep, fabricated from .125 aluminum returns and backs. Paint cabinet satin finish Black polyurethane.
 - B** Faces to be 3/16"(5mm) White acrylic. 1"(25mm) Black Trimcap with square head screws retainer edging. Graphics of logo to be 1st surface 3M Translucent Scotchcal vinyl. Copy to show thru White of Holly Green #3630-76 background. Logo to show thru White of Black #230-22 background.
 - C** Internally illuminate logo disk with 8300 Bright White, 30 ma, neon glass grid. Power with 120v, self-contained France transformer, or equal.
 - D** Fasten to wall with required fasteners.
 - E** 20ga Metal Z-Bracket to support the Neon Supports

Sign must be approved by the National Electrical Code, Underwriters Laboratory, CUL, and all applicable local codes.

Disconnect switch in primary to be within sight of sign (sign includes power supply enclosure) REF: NEC 110-3 [B] 600-2, 600-4

Primary electrical source (1/2"(13mm) conduit minimum) REF: NEC 600-6, 600-21



Back to Sign
Emergency Checkpage
Form No. E21157

June 2nd, 2004
DATE

REVISIONS



STARBUCKS COFFEE COMPANY
 2401 LYNN AVENUE SOUTH
 DENVER, COLORADO 80226
 (303) 596-4000

THIS BLOCK OF ARCHITECTURE IS SET IN PLACE BY THE ARCHITECT. PROPERTY OF STARBUCKS COFFEE COMPANY. ALL RIGHTS RESERVED. NO PART OF THIS DRAWING IS TO BE REPRODUCED OR TRANSMITTED IN ANY FORM OR BY ANY MEANS, ELECTRONIC OR MECHANICAL, WITHOUT PERMISSION IN WRITING FROM STARBUCKS COFFEE COMPANY.

ARCHITECT OF RECORD

REV DATE JC DESCRIPTION

STARBUCKS COFFEE
PROJECT: 24 RD & KASSANDRA
 824 RAE LYNN ST
 GRAND JUNCTION, CO. 81505

PROJECT #: 2001C
 CONCEPT: 880 - MED. L
 PALETTE: CLASSIC
 ISSUE DATE: 18 DEC. 2005
 PREP: ARN SCHMIDT
 JC: CHARLES PA
 CHECKED: YERAM MOG
 CDR: STEVE BURR

SHEET TITLE
EXTERIOR ELEVATIONS

SCALE: 1/4"=1'-0"
 (DO NOT SCALE DRAWING)

SHEET NUMBER
A1

SIGNAGE SCHEDULE:

SIGNAGE SCHEDULE											
ITEM	QTY	DESCRIPTION	MANUFACTURER	MODEL #	VOLTS	AMPS	SUPPLY	WASTE	REMARKS	SKU #	SHIP
LOGOS											
5353	1	48" SINGLE ILLUM DISK								120074	VD
EXTERIOR											
5410	2	SINGLE LINE FACE LIT 12"			120	8			SPECIFY COLOR (WHITE OR GREEN)		VD
DRIVE THRU											
5815	1	DT ORDER CONFIRMATION POST	DELPH	ORDER CONFIRMATION	120V	15			FOAM FILLED POST		VD
5816	1	CLEARANCE BAR, P'S DR. FACE		FREESTANDING W/ LOGO					DOUBLE FACED LOGO DISK		VD
5837	3	48 W" LIT DIRECTIONAL	PATTISON SIGN		120	8					VD
5860	2	S/F ILLUM DT SIGN 6"		PECO738R							VD
5802	1	DT FREESTANDING MENU B. PANEL	PATTISON SIGN		120	3.3					VD

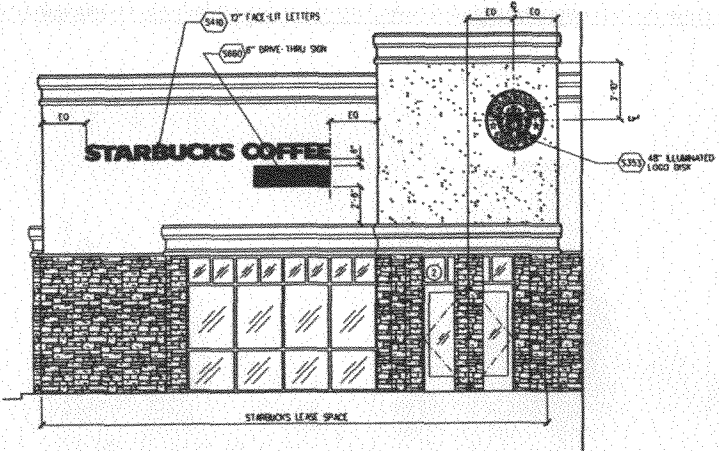

EAST ELEVATION

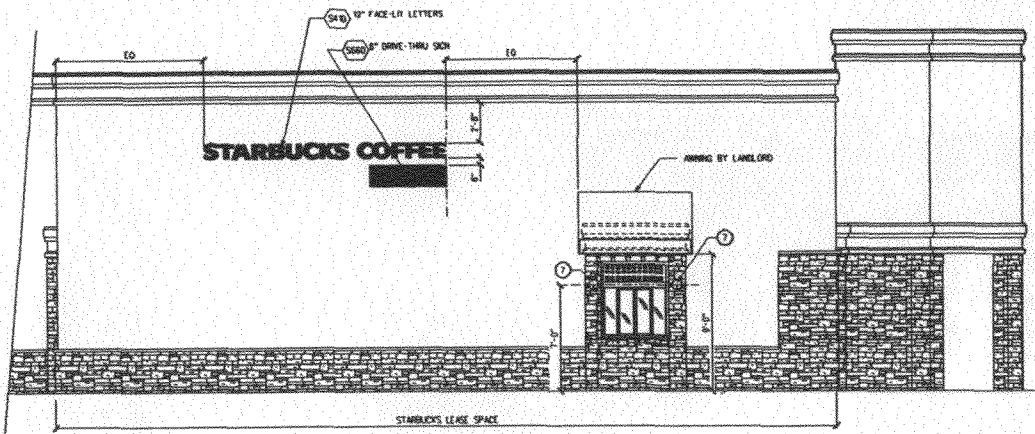

SOUTH ELEVATION

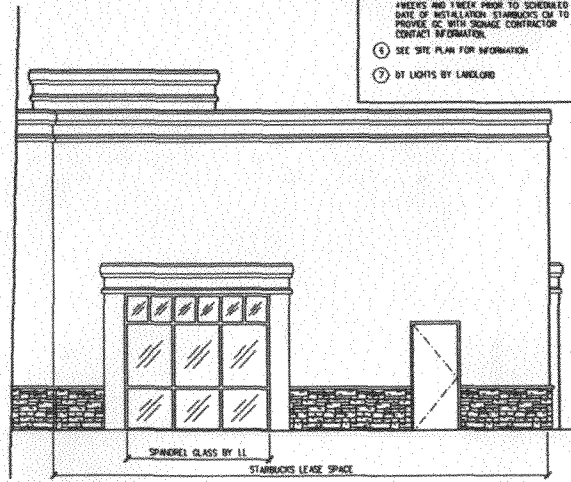

WEST ELEVATION



2x6 WOOD BLOCKING AT ALL SIGNAGE. GC TO COORDINATE WITH LANDLORD CONTRACTOR.

ALL SIGNAGE UNDER SEPARATE PERMIT

NOTE: SIGNAGE CONTRACTOR TO VERIFY COMPLIANCE WITH LOCAL CODES. NOTIFY STARBUCKS' DESIGN CONTACT IF CHANGES ARE REQUIRED. PROVIDE SHOP DRAWINGS FOR ALL SIGNAGE PRIOR TO FABRICATION.

NOTES:

- STARBUCKS CONTRACTS DIRECTLY WITH SIGNAGE CONTRACTOR TO PERMIT, SUPPLY AND INSTALL SIGNAGE. SIGNAGE CONTRACTOR TO VERIFY SIGNAGE COMPLIANCE WITH LOCAL CODES AND OBTAIN PERMIT AND LANDLORD APPROVAL.
- PROVIDE 3" HIGH BLACK ACRYLIC STORE ADDRESS ON GLAZING.
- GC TO PROVIDE SIGNAGE ELECTRICAL CIRCUIT AND FINAL CONNECTION.
- SIGNAGE CONTRACTOR TO SUPPLY SHOP DRAWINGS TO STARBUCKS ON AND TO THE GC AS REFERRED. NOTIFY STARBUCKS CM IMMEDIATELY IF SHOP DRAWINGS OF INSTALLATION IS IN DISCREPANCY WITH STARBUCKS ARCHITECTURAL DRAWINGS.
- COORDINATE AND SCHEDULE SIGNAGE INSTALLATION WITH THE SIGNAGE CONTRACTOR. PROVIDE A MINIMUM SCHEDULING NOTICE OF 7 WEEKS AND 1 WEEK PRIOR TO SCHEDULED DATE OF INSTALLATION. STARBUCKS CM TO PROVIDE GC WITH SIGNAGE CONTRACTOR CONTACT INFORMATION.
- SEE SITE PLAN FOR INFORMATION.
- DT LIGHTS BY LANDLORD.

**SINGLE LINE FACE-LIT INDIVIDUAL LETTER
SPECIFICATION
TAG # S410 / 12" (305mm) LETTER**

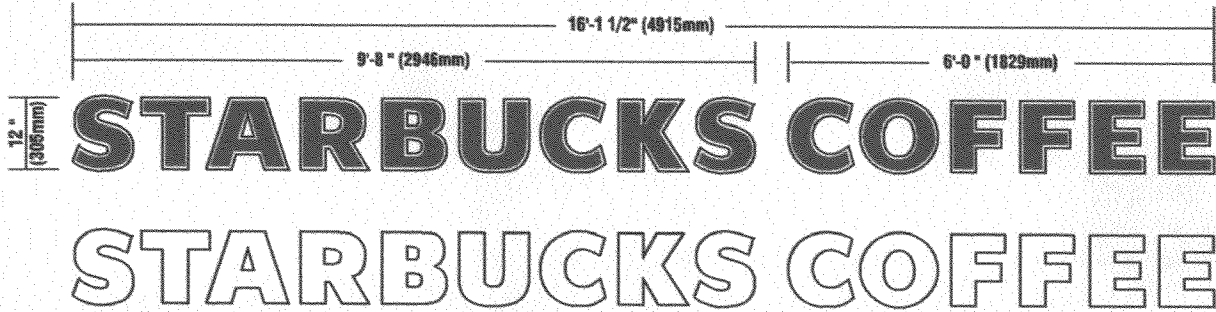

Front View
scale 1/2" = 1'-0"

SPECIFICATIONS:

- A** Internally illuminated channel letters to be fabricated from 0.040 / 3003 aluminum with pre painted White interiors and painted satin finish Black polyurethane exteriors, 5" (127mm) deep. Letters backs to be aluminum pop-riveted to sidewalls and sealed.
- B** Faces to be 3/16" (5mm) White acrylic with 1" (25mm) Black Trimcap retainer edging. If green faces are required, center of faces to be 1st surface 3M Scotchcal #3630-76 Holly Green vinyl with White show thru scratch borders.
- C** Internally illuminate letters with 30 m.a., double-tube of Brillite #4500 / EGL 8300 White neon glass. Power with 120v France transformers. Transformers to be located within remote metal transformer box(es) behind wall.
- D** Remote transformer box(es) to be fabricated from 24 gauge sheet metal construction.
- E** Fasten letters flush to wall with required fasteners.

Sign must be approved by the National Electrical Code, Underwriters Laboratory, CUL, and all applicable local codes.

Tag	Size	Sq.Ft.	Sq.M.	Sq.Ft.²	Sq.M.²	IS
S410	12" (305mm)	16.12	1.5	13.76	1.28	120 8

- 1: Figured as one rectangular area
- 2: Figured as individual letter areas

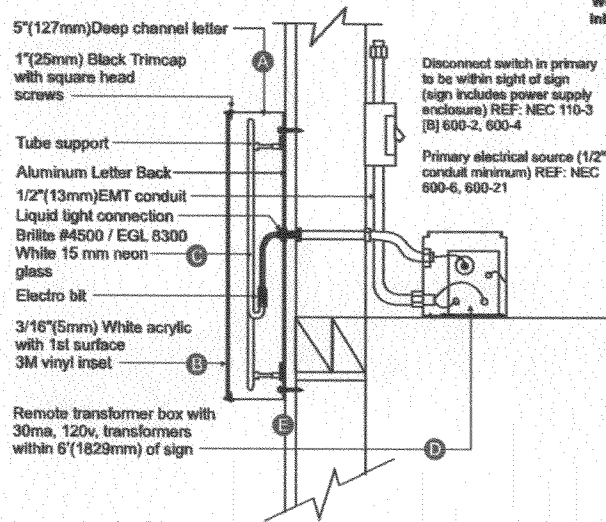

Letter - Section View
Scale n.t.s.

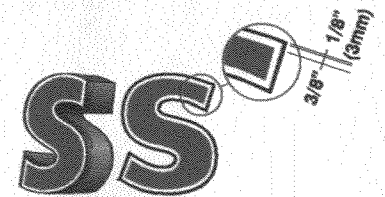

Exposed white border

LxH	Border
12" (305mm)	3/8" (10mm)

IMPORTANT NOTE: NEVER ADD AN INLAY TO THE LETTERS
Always use the green letter Wordmark version with the proper inlay already set. To produce white letters, delete green inlay.



Double Tube Neon Detail - NTS



May 21, 2004

DATE

REVISIONS

SIGNAGE SCHEDULE:

ITEM	QTY	DESCRIPTION	MANUFACTURER	MODEL #	VOLTS	AMPS	SUPL.	WASTE	REMARKS	SKU #	SHIP
LOADS											
1	1	48" SINGLE SLIM SIGN								900774	VO
EXTERIOR											
1	1	48" SINGLE SLIM SIGN									VO
DRIVE THRU											
1	1	COMBINATION POST DELPHI			150V	15			FOAM FILLED POST		VO
2	1	CALL GRAPHIC SIGN							DOUBLE FACED LOGO		VO
3	1	48" SINGLE SLIM SIGN									VO
4	1	48" SINGLE SLIM SIGN									VO
5	1	48" SINGLE SLIM SIGN									VO
6	1	48" SINGLE SLIM SIGN									VO
7	1	48" SINGLE SLIM SIGN									VO



STARBUCKS COFFEE COMPANY
 3001 15TH AVENUE SOUTH
 SEATTLE, WASHINGTON 98148
 206.426.7200

ARCHITECT OF RECORD
 PROJECT # 23910-001
 MESSA
 824 RAE LYNN ST
 GRAND JUNCTION, CO. 81505

NEW DATE AND DESCRIPTION

PROJECT # 23910-001
 MESSA
 824 RAE LYNN ST
 GRAND JUNCTION, CO. 81505

CONTRACTOR
 PROJECT # 23910-001
 MESSA
 824 RAE LYNN ST
 GRAND JUNCTION, CO. 81505

SHEET TITLE
 EXTERIOR ELEVATIONS
 SCALE: 1/4"=1'-0"
 (DO NOT SCALE DRAWINGS)
 SHEET NUMBER **A1.0**

NOTES:

- STARBUCKS CONTRACTOR VERIFY WITH SIGNAGE CONTRACTOR AND ARCHITECT OF RECORD AT ALL SIGNAGE LOCATIONS TO VERIFY ALL SIGNAGE CONTRACT WITH LOCAL CODES AND WITH POWER AND LANDLORD APPROVAL.
- PROVIDE 3" HIGH BLACK ALUMINUM STORE ADDRESS IN GLASS.
- GC TO PROVIDE SIGNAGE ELECTRICAL CIRCUIT AND FINAL CONNECTION.
- STARBUCKS CONTRACTOR TO VERIFY WITH SIGNAGE CONTRACTOR AND ARCHITECT OF RECORD AT ALL SIGNAGE LOCATIONS TO VERIFY ALL SIGNAGE CONTRACT WITH LOCAL CODES AND WITH POWER AND LANDLORD APPROVAL.
- COORDINATE AND VERIFY SIGNAGE CONTRACTOR WITH SIGNAGE CONTRACTOR AND ARCHITECT OF RECORD AT ALL SIGNAGE LOCATIONS TO VERIFY ALL SIGNAGE CONTRACT WITH LOCAL CODES AND WITH POWER AND LANDLORD APPROVAL.
- SEE SITE PLAN FOR INFORMATION.
- BY LOCALS BY LANDLORD.

2x6 WOOD BLOCKING AT ALL SIGNAGE. GC TO COORDINATE WITH LANDLORD CONTRACTOR.

ALL SIGNAGE UNDER SEPARATE PERMIT

NOTE: SIGNAGE CONTRACTOR TO VERIFY WITH SIGNAGE CONTRACTOR AND ARCHITECT OF RECORD AT ALL SIGNAGE LOCATIONS TO VERIFY ALL SIGNAGE CONTRACT WITH LOCAL CODES AND WITH POWER AND LANDLORD APPROVAL. PROVIDE SHOP DRAWINGS FOR ALL SIGNAGE PRIOR TO FABRICATION.

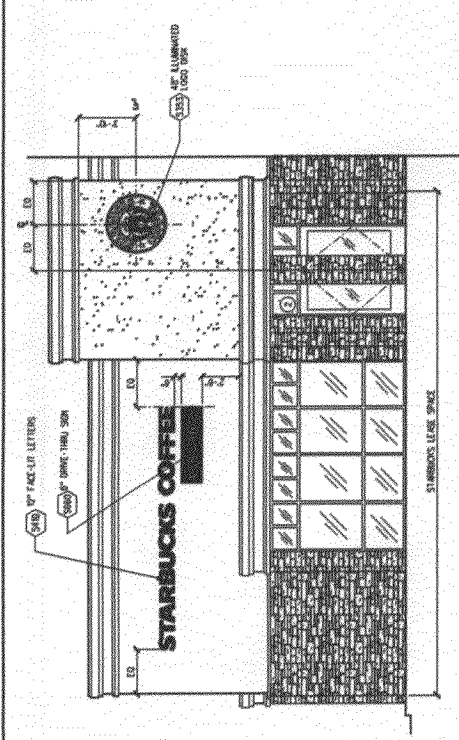

EAST ELEVATION

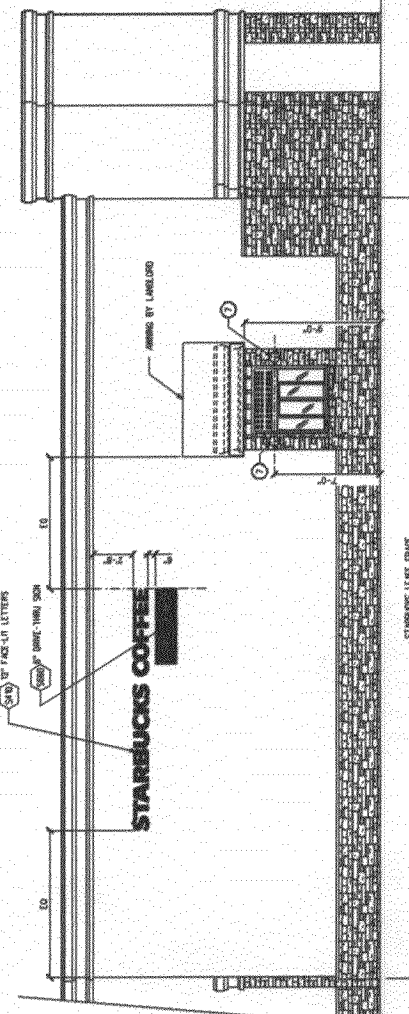

SOUTH ELEVATION

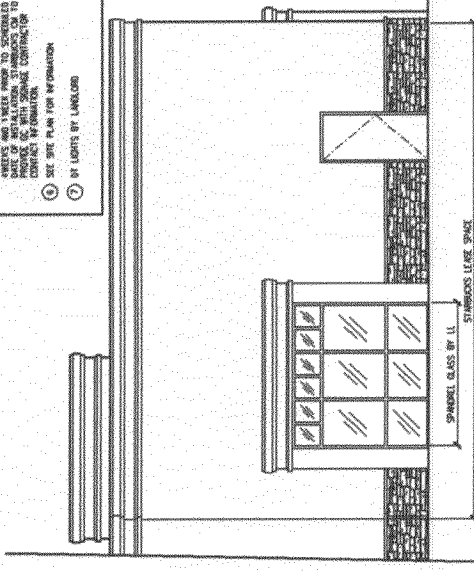

WEST ELEVATION



**SINGLE LINE FACE-LIT INDIVIDUAL LETTER
SPECIFICATION
TAG # S410 / 12" (305mm) LETTER**

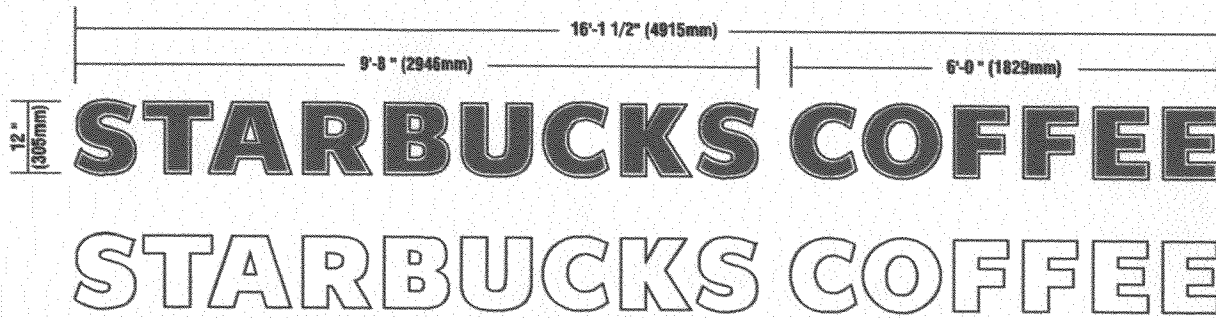

Front View
scale 1/2" = 1'-0"

SPECIFICATIONS:

- (A)** Internally illuminated channel letters to be fabricated from 0.040 / 3003 aluminum with pre painted White interiors and painted satin finish Black polyurethane exteriors, 5"(127mm) deep. Letters backs to be aluminum pop-riveted to sidewalls and sealed.
- (B)** Faces to be 3/16"(5mm) White acrylic with 1"(25mm) Black Trimcap retainer edging. If green faces are required, center of faces to be 1st surface 3M Scotchcal #3630-76 Holly Green vinyl with White show thru scratch borders.
- (C)** Internally illuminate letters with 30 m.a., double-tube of Brillite #4500 / EGL 8300 White neon glass. Power with 120v France transformers. Transformers to be located within remote metal transformer box(es) behind wall.
- (D)** Remote transformer box(es) to be fabricated from 24 gauge sheet metal construction.
- (E)** Fasten letters flush to wall with required fasteners.

Sign must be approved by the National Electrical Code, Underwriters Laboratory, CUL, and all applicable local codes.

Tag	Size	Sq.Ft. ¹	Sq.M. ¹	Sq.Ft. ²	Sq.M. ²	Volts	Amps
S410	12" (305mm)	16.12	1.5	13.76	1.28	120	8

- 1: Figured as one rectangular area
- 2: Figured as individual letter areas

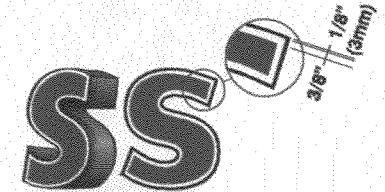

Exposed white border

Ltr.Ht	Border
12" (305mm)	3/8" (10mm)

**IMPORTANT NOTE: NEVER
ADD AN INLAY TO THE LETTERS**
Always use the green letter
Wordmark version with the proper
inlay already set. To produce white
letters, delete green inlay.



Double Tube
Neon Detail - NTS

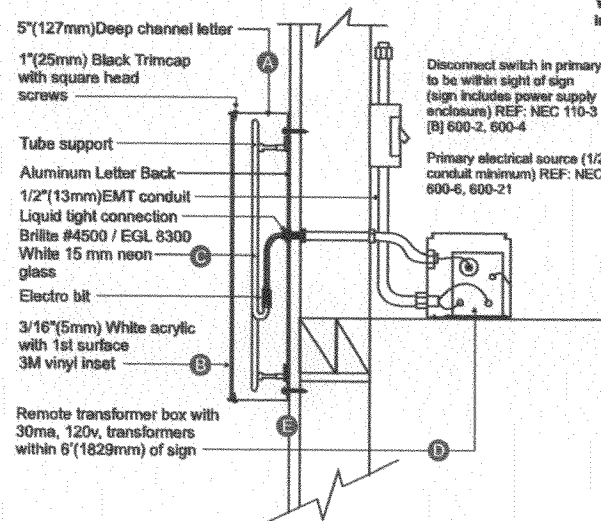

Letter - Section View
Scale n.t.s.

May 21, 2004
DATE

REVISIONS



STARBUCKS COFFEE COMPANY
 2401 WINDLANDER BOULEVARD
 DENVER, COLORADO 80202
 (303) 539-5878

THIS DRAWING IS AN EXCLUSIVE PROPERTY OF STARBUCKS COFFEE COMPANY. IT IS TO BE USED ONLY FOR THE PROJECT AND SITE SPECIFICALLY IDENTIFIED HEREIN. IT IS NOT TO BE REPRODUCED, COPIED, OR TRANSMITTED IN ANY FORM OR BY ANY MEANS, ELECTRONIC OR MECHANICAL, INCLUDING PHOTOCOPYING, RECORDING, OR BY ANY INFORMATION STORAGE AND RETRIEVAL SYSTEM, WITHOUT THE WRITTEN PERMISSION OF STARBUCKS COFFEE COMPANY.

ARCHITECT OF RECORD

REV DATE JC DESCRIPTION

STARBUCKS COFFEE
PROJECT: 24 RD & KASSANDRA
 624 RAE LYNN ST
 GRAND JUNCTION, CO. 81505

PROJECT #: 23010
 CONCEPT: MBG - MID LI
 PALETTE: CLASSICO
 ISSUE DATE: 08 DEC. 2008
 PREP: AMY SCHWABER
 CHECKED: CHARLIE FINE
 DATE: YVESM HOC
 DATE: STEVE BLUM

SHEET TITLE
EXTERIOR ELEVATIONS

SCALE: 1/4" = 1'-0"
(DO NOT SCALE DRAWING)

SHEET NUMBER
A1

SIGNAGE SCHEDULE:

SIGNAGE SCHEDULE											
ITEM	QTY	DESCRIPTION	MANUFACTURER	MODEL #	VOLTS	AMPS	SUPPLY	WASTE	REMARKS	SKU #	SHIP
LOGOS											
S353	1	48" SINGLE ILLUM DUSH								100074	VD
EXTERIOR											
S410	2	SINGLE LINE FACE LIT 12"			120	8			SPECIFY COLOR (WHITE OR GREEN)		VD
DRIVETHRU											
S815	1	DT ORDER CONFIRMATION POST	DELPH	ORDER CONFIRMATION	120V	15			FOAM FILLED POST		VD
S816	1	CLEARANCE BAR, P.S. OBL. FACE		FREE STANDING W/ LOGO					DOUBLE FACED LOGO DUSH		VD
S837	3	48" W. LIT DIRECTIONAL	PATISSON SIGN		120	0					VD
S860	2	S/P ILLUM DT SIGN 6"		PK007368							VD
S802	1	DT FREE STANDING MENU 5' PANEL	PATISSON SIGN		120	3.3					VD

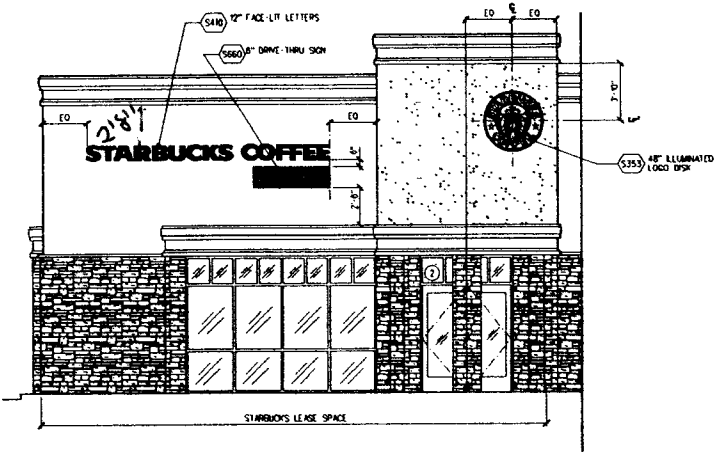

EAST ELEVATION



2x6 WOOD BLOCKING AT ALL SIGNAGE. GC TO COORDINATE WITH LANDLORD CONTRACTOR.

ALL SIGNAGE UNDER SEPARATE PERMIT

NOTE: SIGNAGE CONTRACTOR TO VERIFY COMPLIANCE WITH LOCAL CODES. NOTIFY STARBUCKS' DESIGN CONTACT IF CHANGES ARE REQUIRED. PROVIDE SHOP DRAWINGS FOR ALL SIGNAGE PRIOR TO FABRICATION.

NOTES:

- STARBUCKS CONTRACTS DIRECTLY WITH SIGNAGE CONTRACTOR TO PERMIT, SUPPLY AND INSTALL SIGNAGE. SIGNAGE CONTRACTOR TO VERIFY SIGNAGE COMPLIANCE WITH LOCAL CODES AND OBTAIN PERMIT AND LANDLORD APPROVAL.
- PROVIDE 3" HIGH BLACK ACRYLIC STORE ADDRESS ON GLAZING.
- GC TO PROVIDE SIGNAGE ELECTRICAL CIRCUIT AND FINAL CONNECTION.
- SIGNAGE CONTRACTOR TO SUPPLY SHOP DRAWINGS TO STARBUCKS ON AND TO THE GC AS NEEDED. NOTIFY STARBUCKS IMMEDIATELY IF SHOP DRAWINGS OF INSTALLATION IS IN DISCREPANCY WITH STARBUCKS ARCHITECTURAL DRAWINGS.
- COORDINATE AND SCHEDULE SIGNAGE INSTALLATION WITH THE SIGNAGE CONTRACTOR PROVIDING A MINIMUM SCHEDULING NOTICE OF 4 WEEKS AND 1 WEEK PRIOR TO SCHEDULED DATE OF INSTALLATION. STARBUCKS ON TO PROVIDE GC WITH SIGNAGE CONTRACTOR CONTACT INFORMATION.
- SEE SITE PLAN FOR INFORMATION.
- DT LIGHTS BY LANDLORD.

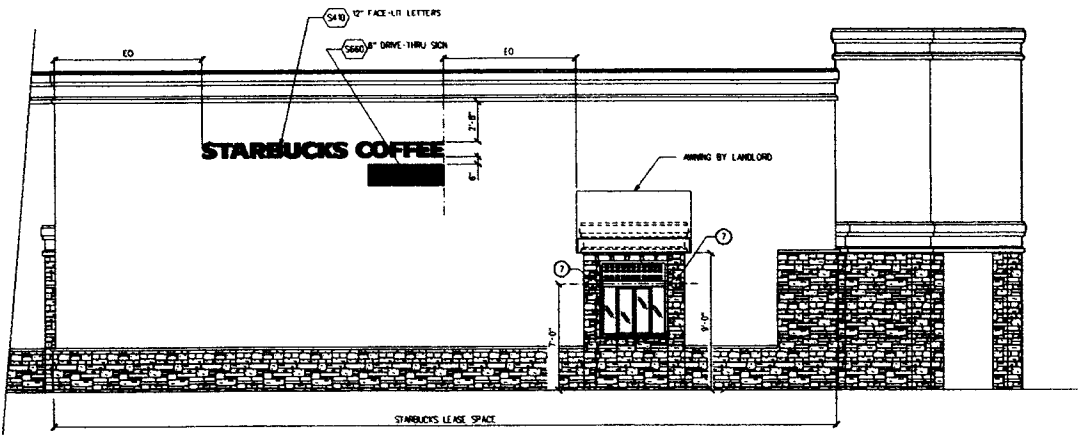

SOUTH ELEVATION

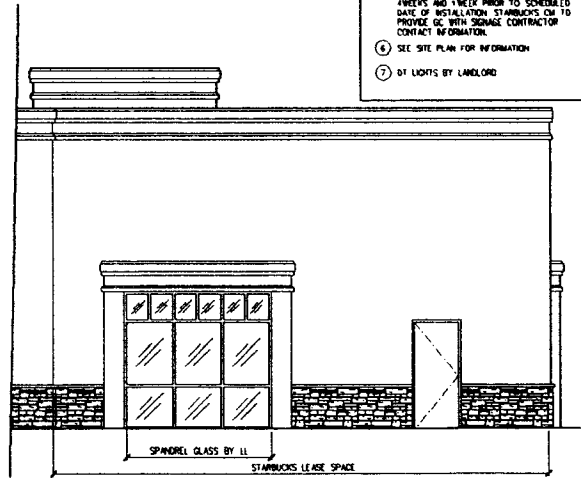
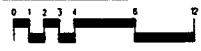

WEST ELEVATION

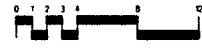

46" D/F DRIVE THRU ILLUMINATED DIRECTIONAL SIGN WITHOUT LOGO DISK SPECIFICATIONS

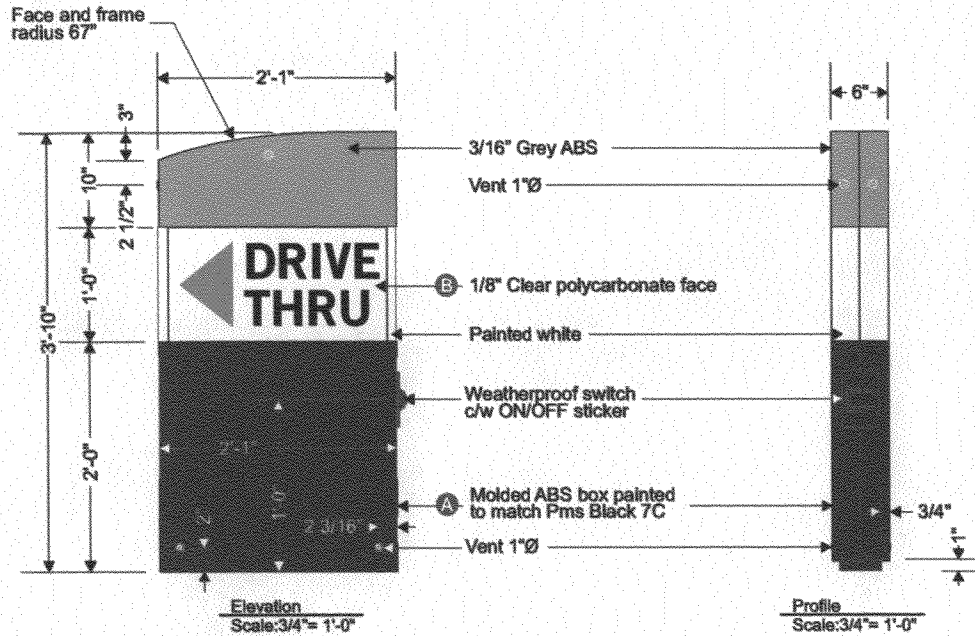

Other Side
Not To Scale

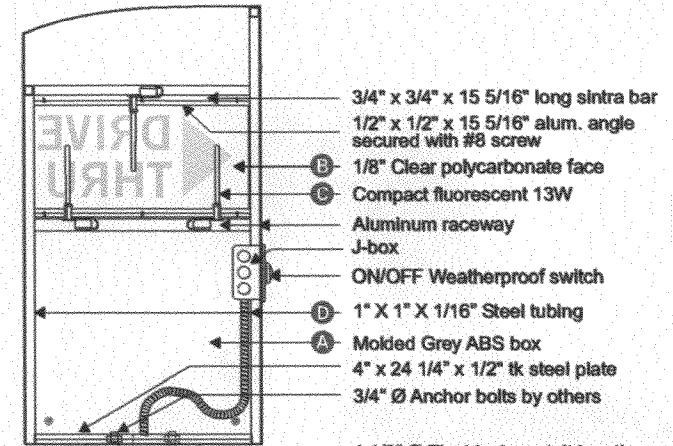

Profile
Scale: 3/4" = 1'-0"

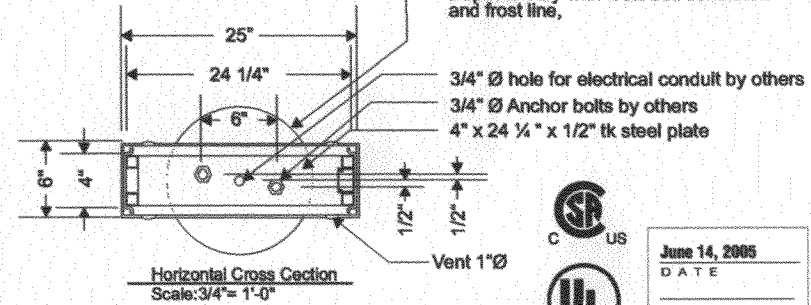

Horizontal Cross Section
Scale: 3/4" = 1'-0"

SPECIFICATIONS:

- A Double faced internally illuminated directional sign. Cabinet to be 6" deep molded with 3/16" Grey ABS, middle painted White and lower section painted PMS Black 7C.
- B Faces to be 1/8" clear polycarbonate. 2nd surface 3M Translucent Scotchcal vinyl #3630-36 Green arrow & #3630-22 Black letters with #3630-20 white diffuser
- C Internally illuminate with sign lite compact fluorescent c/w BLH 13-1-6 ballast
- D Internal structure per vertical cross section
- E All screws must be Robertson square head.
- F Sign must be approved by the National Electrical Code, Underwriters Laboratory, CSA, and all applicable local codes.

Tag Number	Sq.Ft. ¹	Sq.Ft. ²	Volts	Amps
S637	1.9	8.0	120	0.9

- 1: Figured as illuminated center part
- 2: Figured as complete signage



Board Sign
Product Listing
Item No. E21197

June 14, 2005
DATE

REVISIONS

46" D/F DRIVE THRU ILLUMINATED DIRECTIONAL SIGN WITHOUT LOGO DISK SPECIFICATIONS

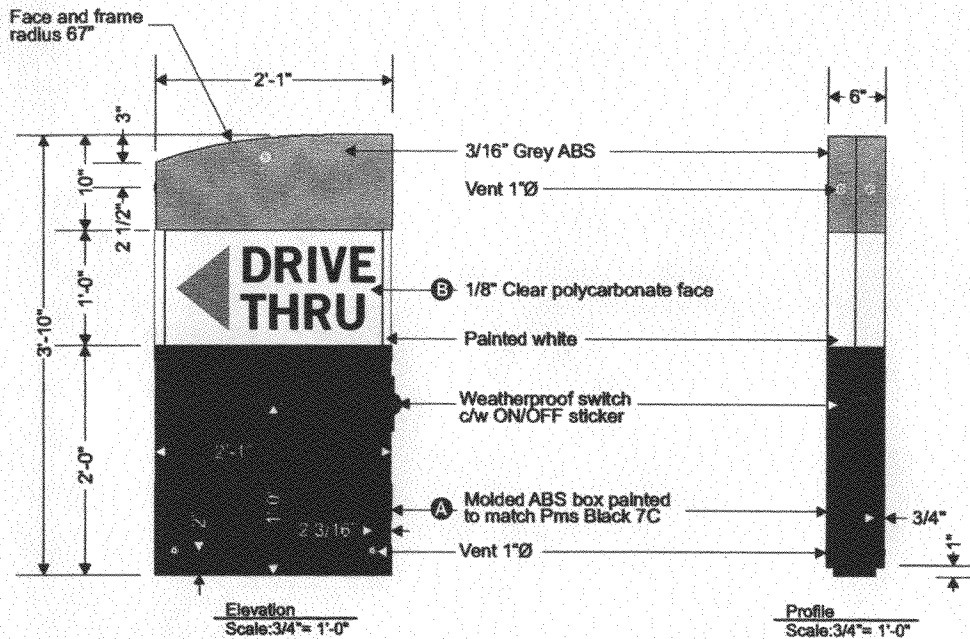

Other Side
Not To Scale

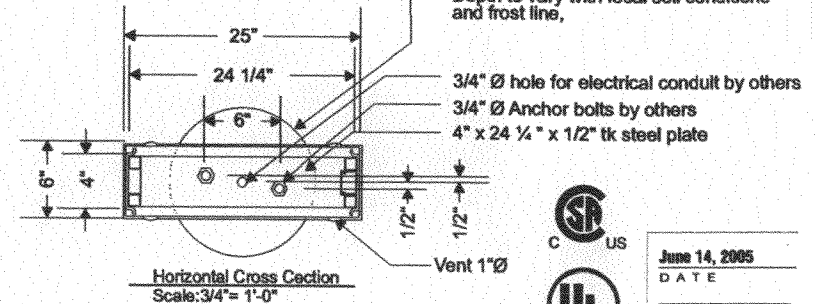
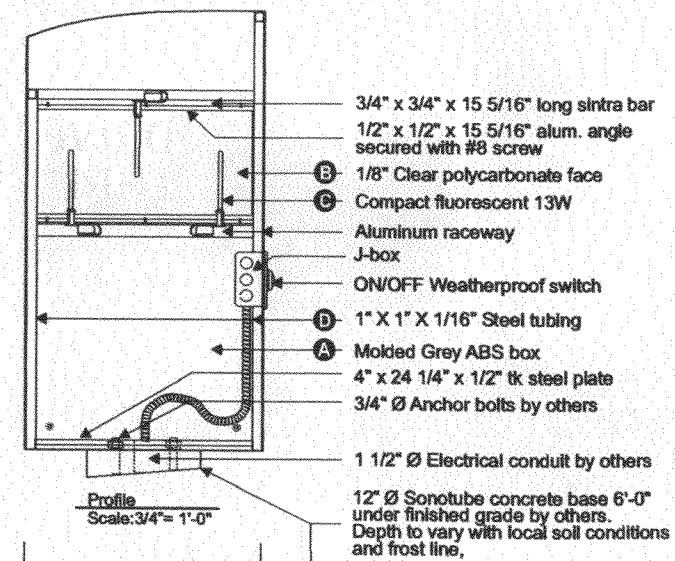

- SPECIFICATIONS:**
- A** Double faced internally illuminated directional sign. Cabinet to be 6" deep molded with 3/16" Grey ABS , middle painted White and lower section painted PMS Black 7C.
 - B** Faces to be 1/8" clear polycarbonate. 2nd surface 3M Translucent Scotchcal vinyl.#3630-36 Green arrow & #3630-22 Black letters with #3630-20 white diffuser
 - C** Internally illuminate with sign lite compact fluorescent c/w BLH 13-1-6 ballast
 - D** Internal structure per vertical cross section
 - E** All screws must be Robertson square head.
 - F** Sign must be approved by the National Electrical Code, Underwriters Laboratory, CSA, and all applicable local codes.

Tag Number	Sq.Ft. ¹	Sq.Ft. ²	Volts	Amps
S637	1.9	8.0	120	0.9

1: Figured as illuminated center part
2: Figured as complete signage



Double Sign
Designs Electrical
Suite No. E21177

June 14, 2005
DATE

REVISIONS

46" D/F DRIVE THRU ILLUMINATED DIRECTIONAL SIGN WITHOUT LOGO DISK INSTALLATION

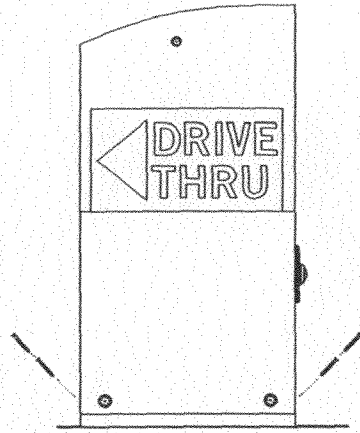

Elevation
Scale: 1" = 1'-0"

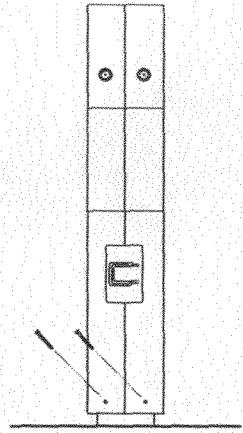

Profile
Scale: 1" = 1'-0"

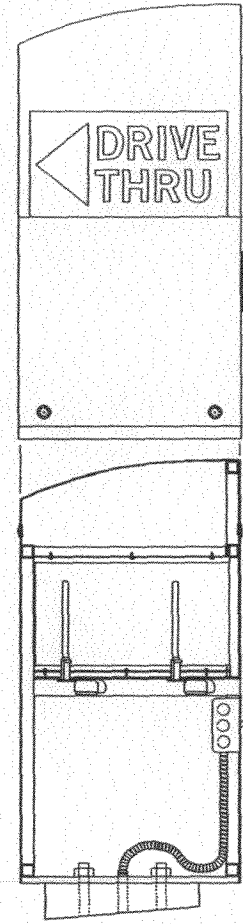

Vertical Cross Section
Scale: 1" = 1'-0"

- Step 1
Remove the bottom screws (2 each end)
- Step 2
Remove the decor from the frame
- Step 3
Anchor the frame to the base and hook-up electrical
- Step 4
Reverse steps 2 & 1 to complete installation

Tag Number	Sq.Ft. ¹	Sq.Ft. ²	Volts	Amps
S637	1.9	8.0	120	0.9

1: Figured as illuminated center part
2: Figured as complete signage



June 14, 2005
DATE

REVISIONS



**FACES FOR DIRECTIONAL SIGNS
13" X 24 1/2"**

Installation: Interior Exterior
 Electrical specifications:
 Volts: _____ Amp: _____ Circ.: _____

#	Descriptions
1	1/8" CLEAR LEXAN WITH VINYL APPLIED TO SECOND SURFACE

FACE	SIDE A	SIDE B

Notes:
 - THE FONT TO USE IS TRADEGOTHIC BOLD

#	Colors
A	GREEN VINYL: 3630-76
B	BLACK VINYL: 3630-22
C	WHITE DIFFUSER: 3630-20

IT IS AGREED THAT THE CLIENT IS ENTIRELY RESPONSIBLE TO INSTALL THE CONCRETE BASES PER ENSEIGNES PATTISON SIGN GROUP'S TECHNICAL DRAWINGS OR THE EQUIVALENT. WHERE AN EXISTING BASE IS USED, THE CLIENT AGREES TO CHECK IF THE CONCRETE BASE CAN SUPPORT THE SIGN AS SUPPLIED BY ENSEIGNES PATTISON SIGN GROUP. ENSEIGNES PATTISON SIGN GROUP WILL NOT ACCEPT ANY LIABILITY.



Tel (506) 733-5506 Fax (506) 737-1740 Toll Free 1-800-561-8798

Client:	STARBUCKS COFFEE		
Site:	VARIOUS		
Consultant:	JOHN FERRARI		
Draftsman:	TONY TOUSSAINT	Date:	10.06.05
Page:	1 / 1	Scale:	1 1/2" = 1'-0"
Project:	DIRECTIONAL 13x24 1/2		

pprobation du client: _____ Date: / /

www.pattisonsign.com

DESIGN ET LA PROPRIÉTÉ EXCLUSIVE D'ENSEIGNES PATTISON SIGN GROUP. TOUTE REPRODUCTION TOTALE OU PARTIELLE EST STRICTEMENT INTERDITE SANS L'AUTORISATION ÉCRITE DE LA COMPAGNIE.

POUR PRODUCTION
 PAR/BY: MP
 DATE: 1/1/06
 CONTRAT/CONTRACT #

46" D/F DRIVE THRU ILLUMINATED DIRECTIONAL SIGN WITHOUT LOGO DISK SPECIFICATIONS

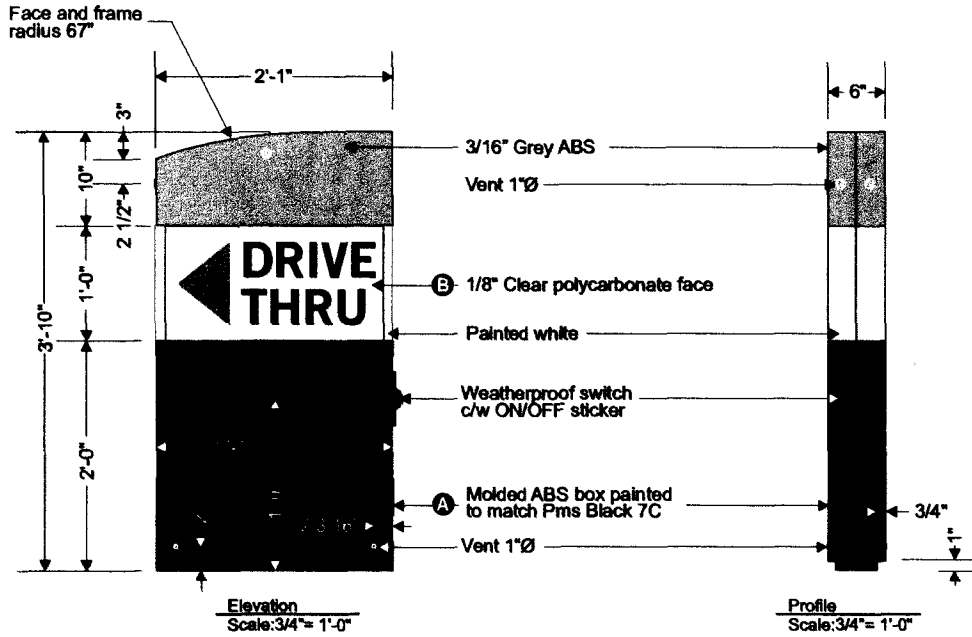

Other Side
Not To Scale

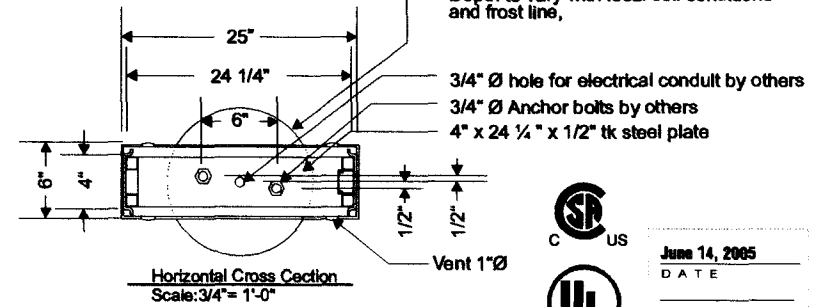
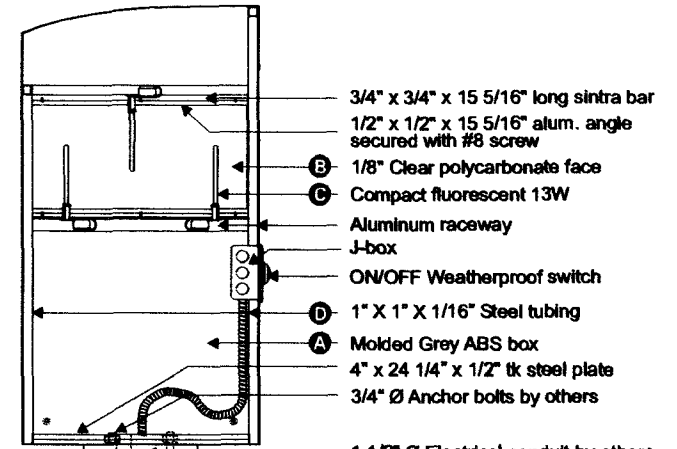

SPECIFICATIONS:

- A** Double faced internally illuminated directional sign. Cabinet to be 6" deep molded with 3/16" Grey ABS, middle painted White and lower section painted PMS Black 7C.
- B** Faces to be 1/8" clear polycarbonate. 2nd surface 3M Translucent Scotchcal vinyl #3630-36 Green arrow & #3630-22 Black letters with #3630-20 white diffuser
- C** Internally illuminate with sign lite compact fluorescent c/w BLH 13-1-6 ballast
- D** Internal structure per vertical cross section
- E** All screws must be Robertson square head.
- F** Sign must be approved by the National Electrical Code, Underwriters Laboratory, CSA, and all applicable local codes.

S637	1.9	8.0	120	0.9
------	-----	-----	-----	-----

- 1: Figured as illuminated center part
- 2: Figured as complete signage



Electric Sign
Designs Division
Issue No. 021107

June 14, 2005
DATE

REVISIONS

46" D/F DRIVE THRU ILLUMINATED DIRECTIONAL SIGN WITHOUT LOGO DISK INSTALLATION

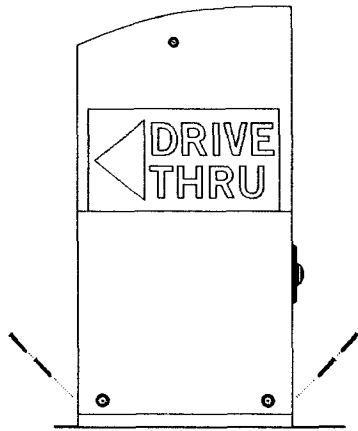

Elevation
Scale: 1" = 1'-0"

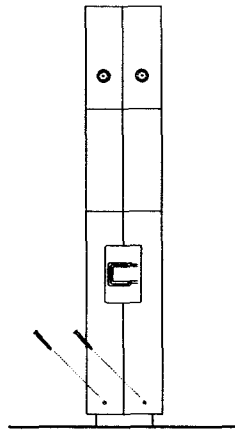

Profile
Scale: 1" = 1'-0"

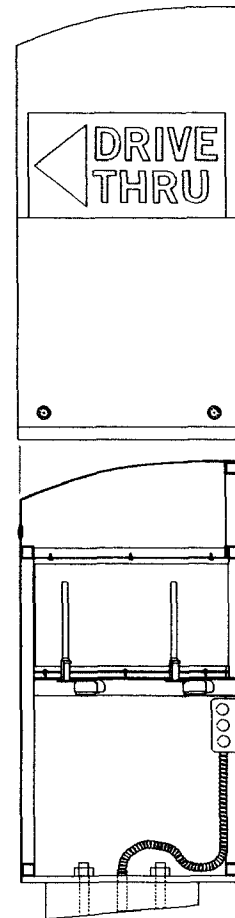

Vertical Cross Section
Scale: 1" = 1'-0"

- Step 1
Remove the bottom screws (2 each end)
- Step 2
Remove the decor from the frame
- Step 3
Anchor the frame to the base and hook-up electrical
- Step 4
Reverse steps 2 & 1 to complete installation

S637	1.9	8.0	120	0.9
-------------	-----	-----	-----	-----

- 1: Figured as illuminated center part
- 2: Figured as complete signage



Electric Sign
Foreign Electrical
Issue No. 621137

June 14, 2005

DATE

REVISIONS



STARBUCKS COFFEE COMPANY
 2000 W. BROADWAY BOULEVARD
 SEATTLE, WASHINGTON 98148
 (206) 426-8800

THIS DRAWING IS UNDESIGNED BY THE ARCHITECT OF RECORD AND IS THE PROPERTY OF THE STARBUCKS COFFEE COMPANY. NO PART OF THIS DRAWING IS TO BE REPRODUCED OR TRANSMITTED IN ANY FORM OR BY ANY MEANS, ELECTRONIC OR MECHANICAL, WITHOUT THE WRITTEN PERMISSION OF THE STARBUCKS COFFEE COMPANY.

ARCHITECT OF RECORD
 AND P. QUINN - AIA, INC. & CO.
 100 S. BRENTWOOD STREET
 LAKEWOOD, CO 80226
 (303) 445-7000 PHONE
 (303) 445-8900 FAX

REV DATE JC DESCRIPTION
 1/20/2006 CASEWORK HAS MODIFIED

STARBUCKS COFFEE
24 RD & KASSANDRA
 624 RAE LYNN ST
 GRAND JUNCTION, CO. 81505
 PROJECT COUNTY: MESA

STORE #: 10876
 PROJECT #: 20010-001
 CONCEPT: BSB - MED. LH
 PALETTE: CLASSICO
 ISSUE DATES: JUL 2005
 PREP: AMY RICHMOND
 JC: CHRISTOPHER PUGH
 CHK: STEVE BLANKENHORN

SHEET TITLE
EXTERIOR ELEVATIONS

SCALE: 1/4" = 1'-0"
 (DO NOT SCALE DRAWINGS)

SHEET NUMBER
A1.0

SIGNAGE SCHEDULE:

SIGNAGE SCHEDULE:											
ITEM	QTY	DESCRIPTION	MANUFACTURER	MODEL #	VOLTS	AMPS	SUPPLY	WASTE	REMARKS	SKU #	SHR
LOGOS											
5353	2	48" SINGLE ILLUM DISK								120074	VD
EXTERIOR											
5430	2	SINGLE FACEWAY FACE LIT 12"			120	8			SPECIFY COLOR (WHITE OR GREEN)		VD
DRIVE THRU											
5815	1	DT ORDER CONFIRMATION POST	DELPHI	ORDER CONFIRMATION	120V	15			FOAM FILLED POST		VD
5816	1	CLEARANCE BAR, 1/2" DIA. FACE		FREE-STANDING W/ LOGO					DOUBLE FACED LOGO DISK		VD
5837	2	48" IN LIT DIRECTIONAL	PATTISON SIGN		120	6					VD
5880	2	5 1/2" ILLUM DT SIGN, 4"		PEDD7388							VD
5882	1	DT FREE-STANDING MENU S. PANEL	PATTISON SIGN		120	3.5					VD

2x6 WOOD BLOCKING AT ALL SIGNAGE. GO TO COORDINATE WITH LANDLORD CONTRACTOR.

ALL SIGNAGE UNDER SEPARATE PERMIT

NOTE: SIGNAGE CONTRACTOR TO VERIFY COMPLIANCE WITH LOCAL CODES. NOTIFY STARBUCKS' DESIGN CONTACT IF CHANGES ARE REQUIRED. PROVIDE SHOP DRAWINGS FOR ALL SIGNAGE PRIOR TO FABRICATION.

NOTES:

- STARBUCKS CONTRACTS DIRECTLY WITH SIGNAGE CONTRACTOR TO REVIEW, SUPPLY, AND INSTALL SIGNAGE. SIGNAGE CONTRACTOR TO VERIFY SIGNAGE COMPLIANCE WITH LOCAL CODES AND OBTAIN PERMIT AND LANDLORD APPROVAL.
- PROVIDE 3" HIGH BLACK ACRYLIC STONE ADDRESS ON GLAZING.
- GC TO PROVIDE SIGNAGE ELECTRICAL CIRCUIT AND FINAL CONNECTION.
- SIGNAGE CONTRACTOR TO SUPPLY SHOP DRAWINGS TO STARBUCKS OR BID TO THE GC. AS NEEDED, NOTIFY STARBUCKS OR INSTALLED P.F. SHOP DRAWINGS OR INSTALLATION IS IN DISCREPANCY WITH STARBUCKS ARCHITECTURAL DRAWINGS.
- COORDINATE AND SCHEDULE SIGNAGE INSTALLATION WITH THE SIGNAGE CONTRACTOR. PROVIDING A WRITTEN SCHEDULING NOTICE OF MEETINGS AND 7 DAYS PRIOR TO SCHEDULING DATE OF INSTALLATION. STARBUCKS OR GC TO PROVIDE GC WITH SIGNAGE CONTRACTOR CONTACT INFORMATION.
- SEE SITE PLAN FOR INFORMATION.
- DT LIGHTS BY LANDLORD.
- MUSIC SPEAKER.

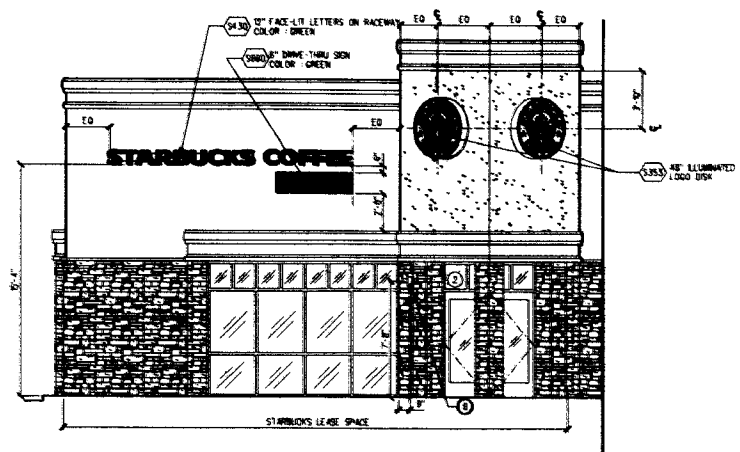

EAST ELEVATION

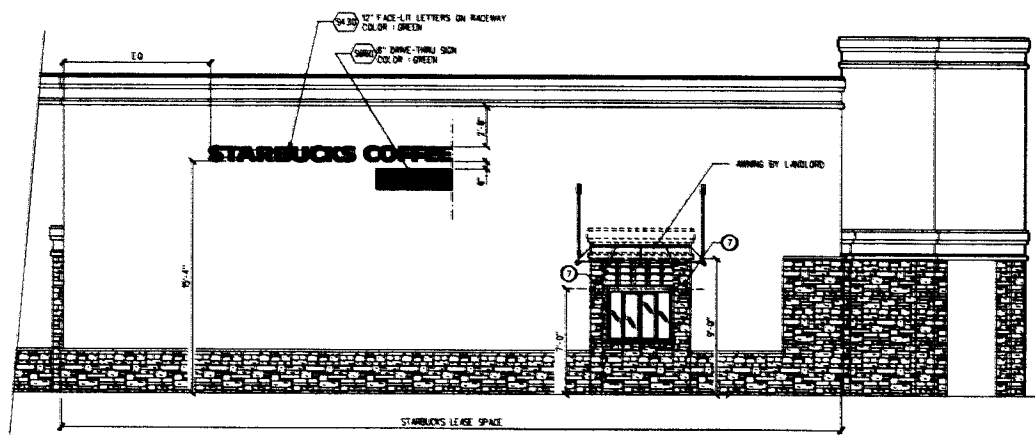

SOUTH ELEVATION

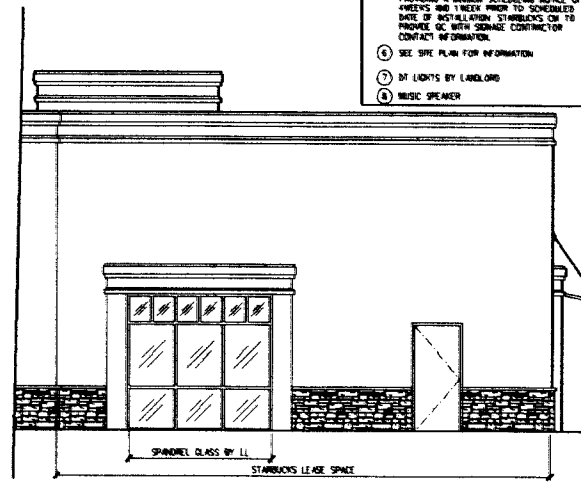

WEST ELEVATION

