



SIGN CLEARANCE

Community Development Department
250 North 5th Street
Grand Junction CO 81501
(970) 244-1430

Clearance No.	_____
Date Submitted	7/30/07
Fee \$	25.00
Zone	C-1

TAX SCHEDULE	2945-261-29-002	CONTRACTOR	Western Neon Sign Co, Inc
BUSINESS NAME	Subway	LICENSE NO.	2070562
STREET ADDRESS	3770 Hwy 50 2692	ADDRESS	3183 HALL AVE, G.J., CO 81504
PROPERTY OWNER	Subway Hwy 50	TELEPHONE NO.	523-4045
OWNER ADDRESS	P.O. Box 2822, G.J., 81502	CONTACT PERSON	John

- | | | |
|-------------------------------------|------------------|--|
| <input checked="" type="checkbox"/> | 1. FLUSH WALL | x2 Square Feet per Linear Foot of Building Facade |
| <input type="checkbox"/> | 2. ROOF | 2 Square Feet per Linear Foot of Building Facade |
| <input type="checkbox"/> | 3. FREE-STANDING | 2 Traffic Lanes - 0.75 Square Feet x Street Frontage |
| <input type="checkbox"/> | 4. PROJECTING | 4 or more Traffic Lanes - 1.5 Square Feet x Street Frontage |
| <input type="checkbox"/> | 5. OFF-PREMISE | 0.5 Square Feet per each Linear Foot of Building Facade |
| | | See #3 Spacing Requirements; Not > 300 Square Feet or < 15 Square Feet |

Externally Illuminated Internally Illuminated Existing Non-Illuminated

(1 - 5)	Area of Proposed Sign:	30	Square Feet	30" X 12'
(1,2,4)	Building Façade:	40	Linear Feet	Building Façade Direction: North South East West
(1 - 4)	Street Frontage:	375	Linear Feet	Name of Street: Hwy 50
(2 - 5)	Height to Top of Sign:	14	Feet	Clearance to Grade: 11'6" Feet
(5)	Distance from all Existing Off-Premise Signs within 600 Feet:	NA	Feet	

EXISTING SIGNAGE/TYPE & SQUARE FOOTAGE:

Mall wall Signage of	480	Sq. Ft.
_____	_____	Sq. Ft.
_____	_____	Sq. Ft.
Total Existing:	_____	Sq. Ft.

FOR OFFICE USE ONLY

Signage Allowed on Parcel for ROW:

Building	144	Sq. Ft.
Free-Standing	468	Sq. Ft.
Total Allowed:	468	Sq. Ft.

COMMENTS: Remove 30' square foot sign + install a new 30' sq ft sign.

NOTE: No sign may exceed 300 square feet. A separate sign clearance is required for each sign. Attach a sketch, to scale, of proposed and existing signage including types, dimensions and lettering. Attach a plot plan, to scale, showing: abutting streets, alleys, easements, driveways, encroachments, property lines, distances from existing buildings to proposed signs and required setbacks. **A SEPARATE PERMIT FROM THE BUILDING DEPARTMENT IS ALSO REQUIRED.**

I hereby attest that the information on this form and the attached sketches are true and accurate.

	7-25-07		7/30/07
Applicant's Signature	Date	Community Development Approval	Date

(White: Community Development) (Canary: Applicant) (Pink: Building Dept) (Goldenrod: Code Enforcement)



SIGN PERMIT

Community Development Department
250 North 5th Street
Grand Junction, CO 81501
(303) 244-1430

PERMIT NO. _____
Date Submitted 1-10-95
FEE \$ 5.00
Tax Schedule 2945-261-29-002
Zone PB

BUSINESS NAME SUBWAY CONTRACTOR Western Neon
STREET ADDRESS 2612 Hwy 50 LICENSE NO 2940176
PROPERTY OWNER SUBWAY ADDRESS 2495 INDUSTRIAL BLVD.
OWNER ADDRESS PO Box 9822 GJ. TELEPHONE NO 242-7843

- 1. FLUSH WALL 2 Square Feet per Linear Foot of Building Facade
 - 2. ROOF 2 Square Feet per Linear Foot of Building Facade
 - 3. FREE-STANDING 2 Traffic Lanes - 0.75 Square Feet x Street Frontage
4 or more Traffic Lanes - 1.5 Square Feet x Street Frontage
 - 4. PROJECTING 0.5 Square Feet per each Linear Foot of Building Facade
 - 5. OFF-PREMISE See #3 Spacing Requirements; Not > 300 Square Feet or < 15 Square Feet
- Externally Illuminated Internally Illuminated Non-Illuminated

- (1 - 5) Area of Proposed Sign 36 Square Feet
- (1,2,4) Building Facade ~~375~~ Linear Feet ~~375~~ ft.
- (1 - 4) Street Frontage 325 ft Linear Feet
- (2,4,5) Height to Top of Sign 10 Feet Clearance to Grade 13 Feet
- (5) Distance from all Existing Off-Premise Signs within 600 Feet _____ Feet

Existing Signage/Type	Sq Ft
<u>Shopping Center Wall Signs</u> <u>480</u>	Sq Ft
<u>PDC SIGN</u> <u>56</u>	Sq Ft
_____	Sq Ft
Total Existing: <u>536</u>	Sq Ft

FOR OFFICE USE ONLY:	
Signage Allowed on Parcel	
Building <u>750</u>	Sq Ft
Free-Standing <u>487</u>	Sq Ft
Total Allowed: <u>750</u>	Sq Ft

COMMENTS: NEW FACE ONLY IN 36 sq SIGN ON
EAST WALL of SUBWAY

NOTE: No sign may exceed 300 square feet. A separate sign permit is required for each sign. Attach a sketch of proposed and existing signage including types, dimensions, lettering, abutting streets, alleys, easements, property lines, and locations. All signs require a separate permit from the Building Department.

[Signature] 1-13-95 [Signature] 1-16-95
Applicant's Signature Date Approved By Date

DUALITE OUTDOOR SIGNAGE

STANDARD FEATURES -- 30" CONTOUR SIGN

- Single face SUBWAY® logo sign designed for use on light-colored background
- Computer-routed pigmented plexiglas face
- SUB - white letters, WAY - yellow letters
- Green contour shape background
- Illumination: (2) F96T 12/CW/HO, (2) F36T 12/CW/HO, fluorescent lamps

Dimensions:

Illuminated letters: 30" High

Overall: 12' 0" x 37 1/2" x 6 1/2" deep

Shipping weight: 250 lbs.

Packed in one box

Electrical:

3.50 amps.

UL and CSA approved

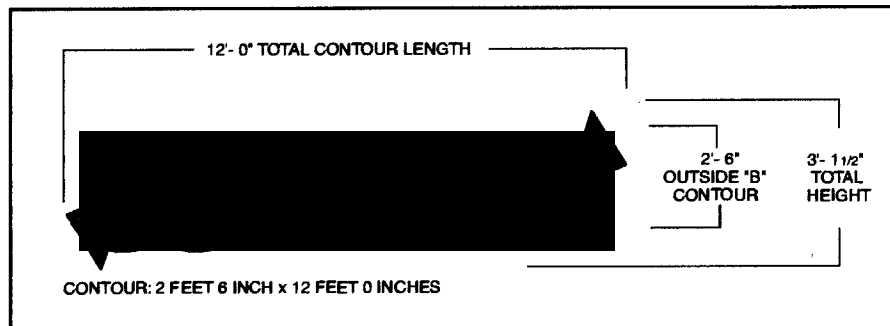

*Warranty: one year: parts and sixty-days: labor

***Signs must be inspected before installation**

DUALITE must be notified within 15 days of delivery of any damage.

Notify DUALITE and the carrier immediately. Do not install the sign.

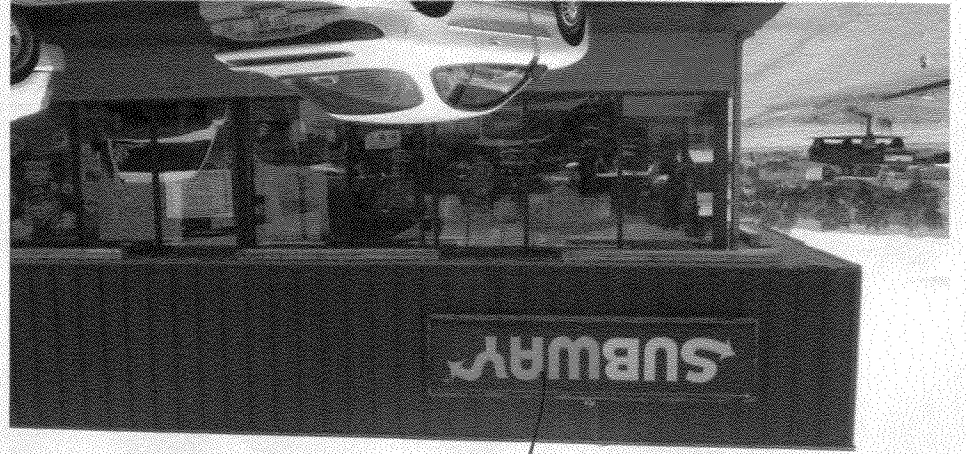
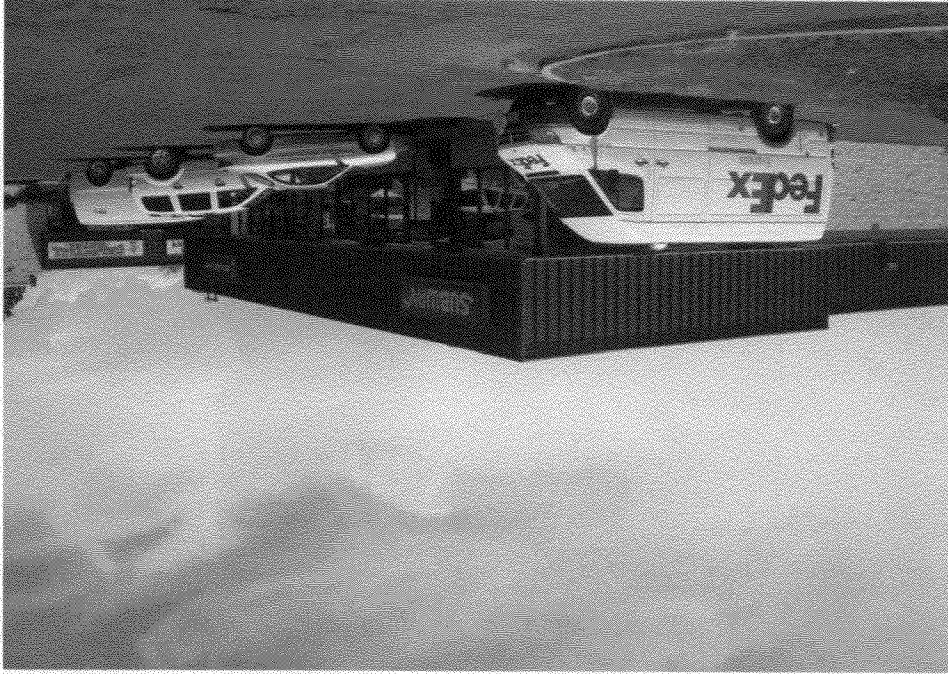

Sign A

