

ABEYTA/WEAVER ANNEXATION NO. 1

SITUATE IN THE NE 1/4 SW 1/4 OF SECTION 16, T1S, R1E, U.M.
 COUNTY OF MESA, STATE OF COLORADO

1 2 3 4

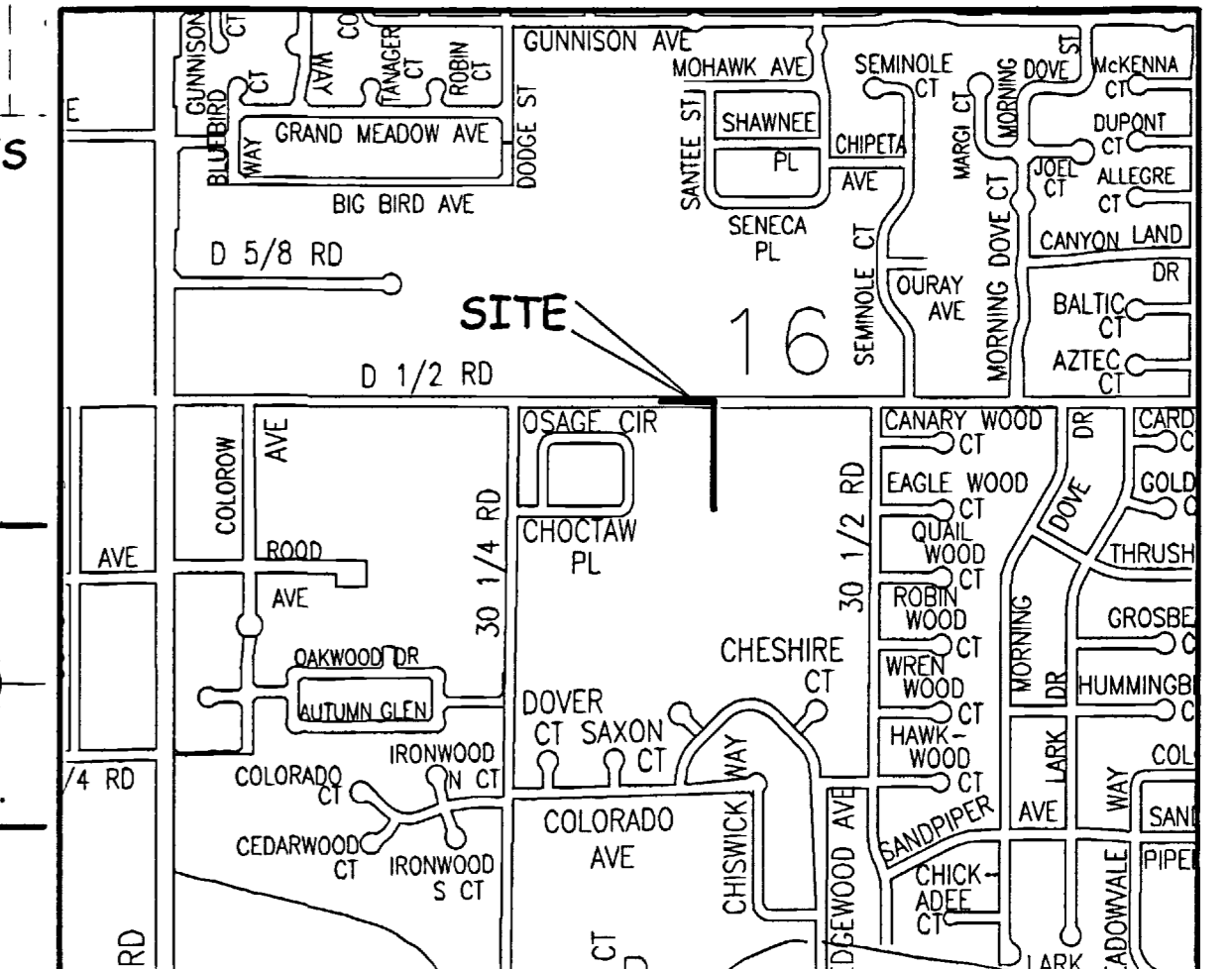

LOCATION MAP: NOT-TO-SCALE

LOT 1
 REPLAT OF VICTORIAN MANOR
 PLAT BOOK 13, PAGE 524
 2943-162-00-195
 2943-162-00-196
 FRUITVALE MEADOWS
 ANNEXATION NO. 2
 ORDINANCE NO. 3098

2943-162-00-036

DAVIS TOWNHOUSES
 (PB 13, PG 83)

FRUITVALE MEADOWS
 ANNEXATION NO. 2
 ORDINANCE NO. 3098

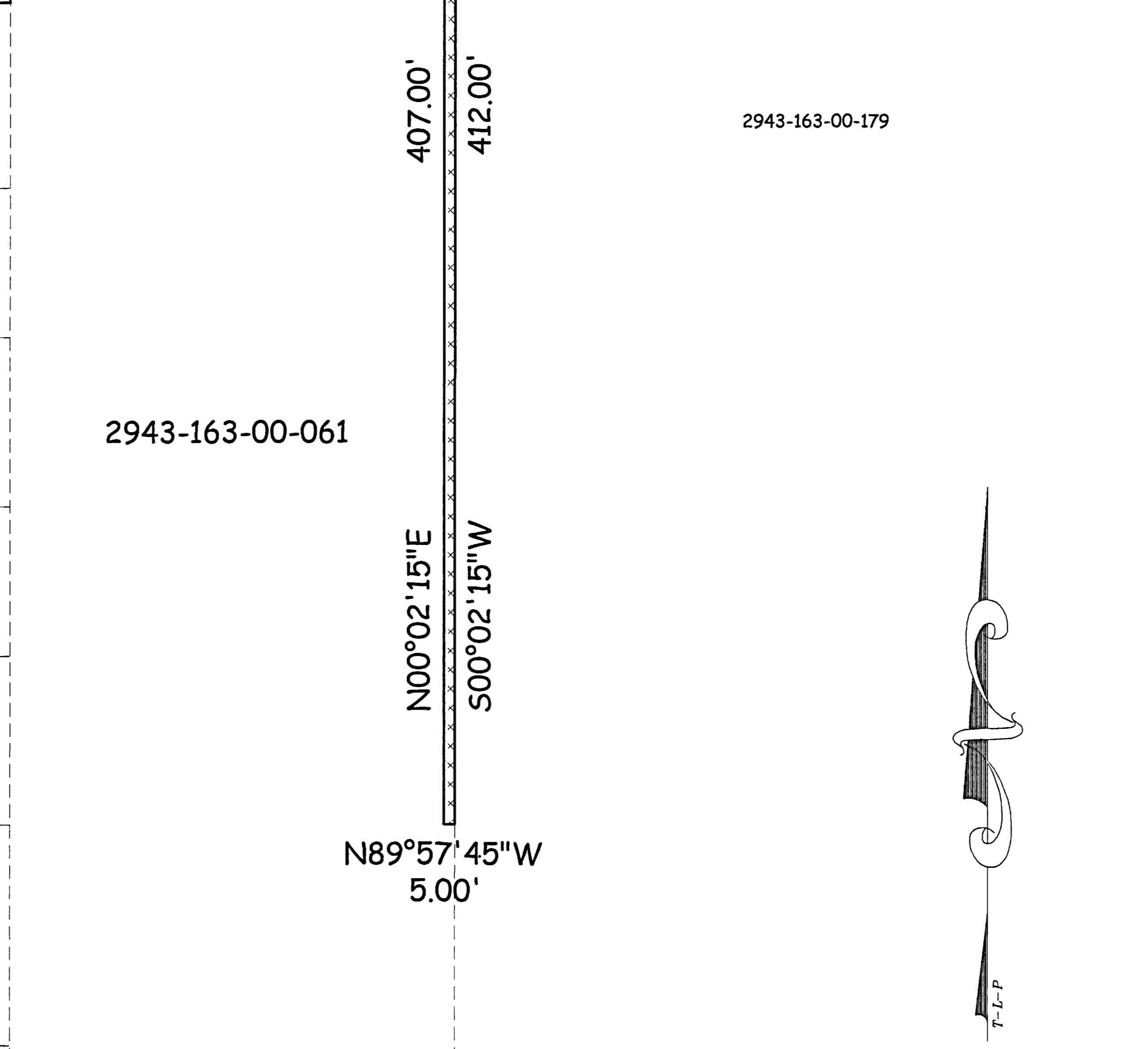
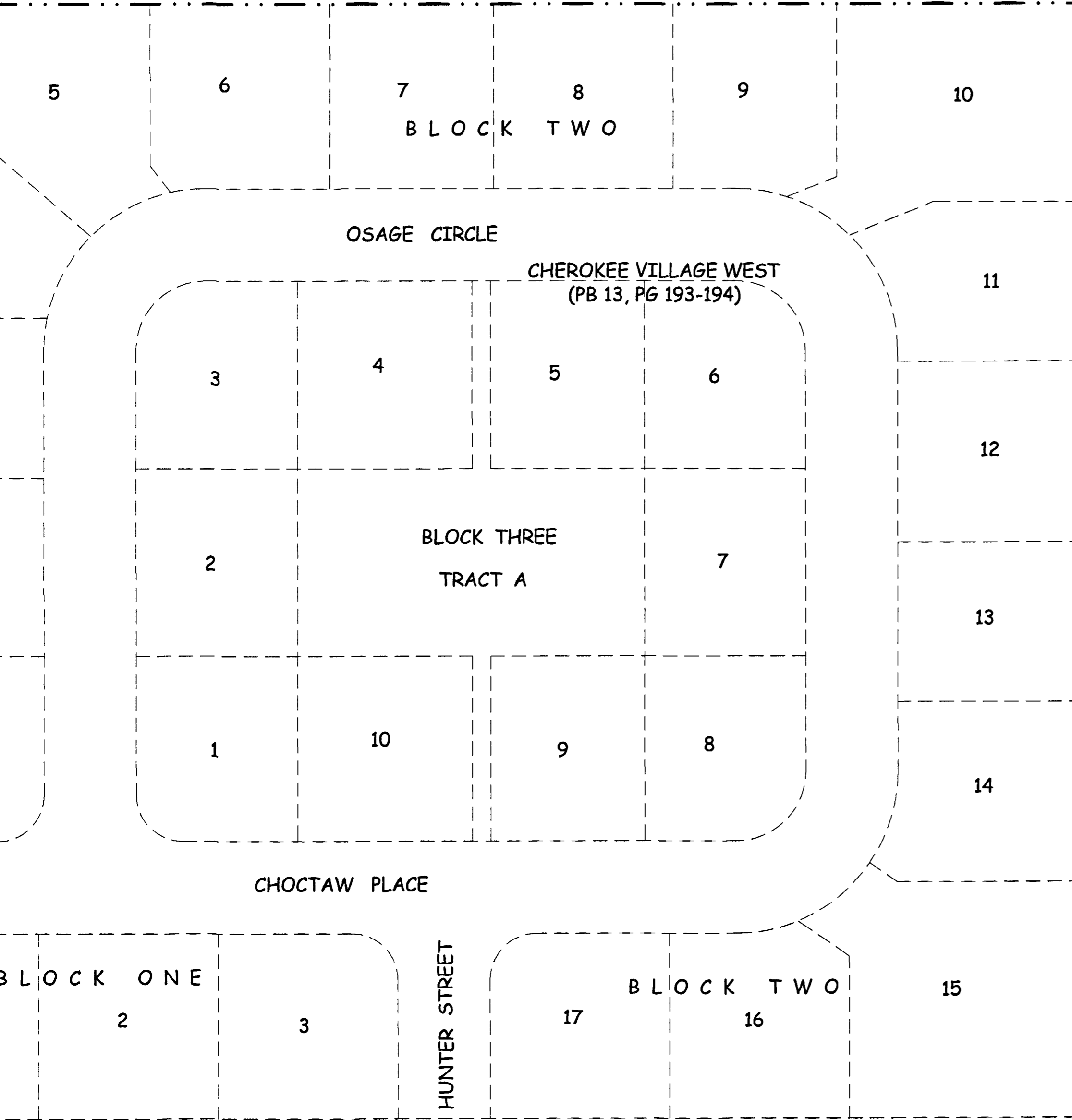
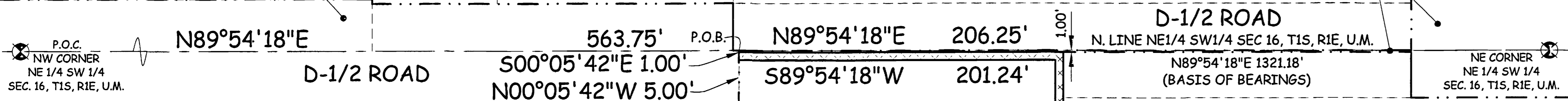

LEGAL DESCRIPTION

A certain parcel of land located in the Northeast Quarter of the Southwest Quarter (NE 1/4 SW 1/4) of Section 16, Township 1 South, Range 1 East, of the Ute Principal Meridian, County of Mesa, State of Colorado, being more particularly described as follows:

Commencing at the Northwest corner of the NE 1/4 SW 1/4 of said Section 16 and assuming the North line of the NE 1/4 SW 1/4 of said Section 16 to bear N89°54'18\"/>

AREA OF ANNEXATION

ANNEXATION PERIMETER	1,236.48 FT
CONTIGUOUS PERIMETER	211.25 FT
AREA IN SQUARE FEET	3,066
AREA IN ACRES	0.07

(CONTAINS NO AREA WITHIN PUBLIC RIGHTS OF WAY)

LEGEND

ANNEXATION BOUNDARY	—
EXISTING CITY LIMITS	---

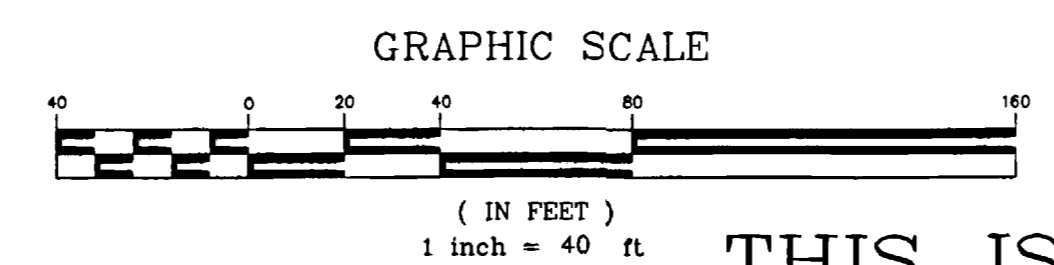

ORDINANCE NO.
 3834

EFFECTIVE DATE
 NOVEMBER 20, 2005

THIS IS NOT A BOUNDARY SURVEY

The Description(s) contained herein have been derived from subdivision plats and deed descriptions as they appear in the office of the Mesa County Clerk and Recorder. This plat does not constitute a legal survey, and is not intended to be used as a means for establishing or verifying property boundary lines.

Peter T. Krick
 PETER T. KRICK, PLS No. 32824
 Professional Land Surveyor for the
 City of Grand Junction
 DATE: October 20, 2005

Notice:
 According to Colorado law you must commence any legal action based upon any defect in this survey within three years after you first discover such defect. In no event may any action based upon any defect in this survey be commenced more than ten years from the date of the certification shown herein.

DRAWN BY	T.L.P.	DATE	08-19-05
DESIGNED BY		DATE	
CHECKED BY	P.T.K.	DATE	
APPROVED BY		DATE	

SCALE
 1" = 40'



PUBLIC WORKS
 AND UTILITIES
 REAL ESTATE DIVISION

ABEYTA/WEAVER ANNEXATION NO. 1
 13061500.tif