

DATE SUBMITTED: 4-17-92

PERMIT NO. 41563 ✓

FEE \$ 10.00
SEE SIGO PERMIT

PLANNING CLEARANCE

GRAND JUNCTION COMMUNITY DEVELOPMENT DEPARTMENT

BLDG ADDRESS 103 North 1st Street

SQ. FT. OF BLDG: 2760

SUBDIVISION Mobheys

SQ. FT. OF LOT: 3500

FILING # BLK # 6 LOT # 1 (CPT)

NO. OF FAMILY UNITS: N/A

TAX SCHEDULE # 2945-154-05-008

NO. OF BUILDINGS ON PARCEL BEFORE THIS PLANNED CONSTRUCTION: 1

OWNER Tevesa Pantuso

USE OF EXISTING BUILDINGS:
Restaurant

ADDRESS 108 West MAIN

DESCRIPTION OF WORK AND INTENDED USE:
Awning

TELEPHONE: 243-2603

REQUIRED: Two plot plans showing parking, landscaping, setbacks to all property lines, and all streets which abut the parcel.

FOR OFFICE USE ONLY

ZONE C-2

FLOODPLAIN: YES NO

SETBACKS: FRONT

GEOLOGIC HAZARD: YES NO

SIDE REAR

CENSUS TRACT: 9 TRAFFIC ZONE: 43

MAXIMUM HEIGHT N/A

PARKING REQ'MT N/A

LANDSCAPING/SCREENING REQUIRED:

SPECIAL CONDITIONS:

N/A

Modifications to this Planning Clearance must be approved, in writing, by this Department. The structure approved by this application cannot be occupied until a Certificate of Occupancy is issued by the Building Department (Section 307, Uniform Building Code).

Any landscaping required by this permit shall be maintained in an acceptable and healthy condition. The replacement of any vegetation materials that die or are in an unhealthy condition shall be required.

I hereby acknowledge that I have read this application and the above is correct, and I agree to comply with the requirements above. Failure to comply shall result in legal action.

Karl M. [Signature]
Department Approval
4/12/92
Date Approved

[Signature]
Applicant Signature
4-17-92
Date

VALID FOR SIX MONTHS FROM DATE OF ISSUANCE (Section 9-3-2 D Grand Junction Zoning & Development Code)

Canvas Products Co
588 25 Road
Grand Junction, Co 81505
Tom Dykstra
242-1453

Sports Page
103 North 1st street
Grand Jct, Co 81501
Lonnie Miller
241-4010

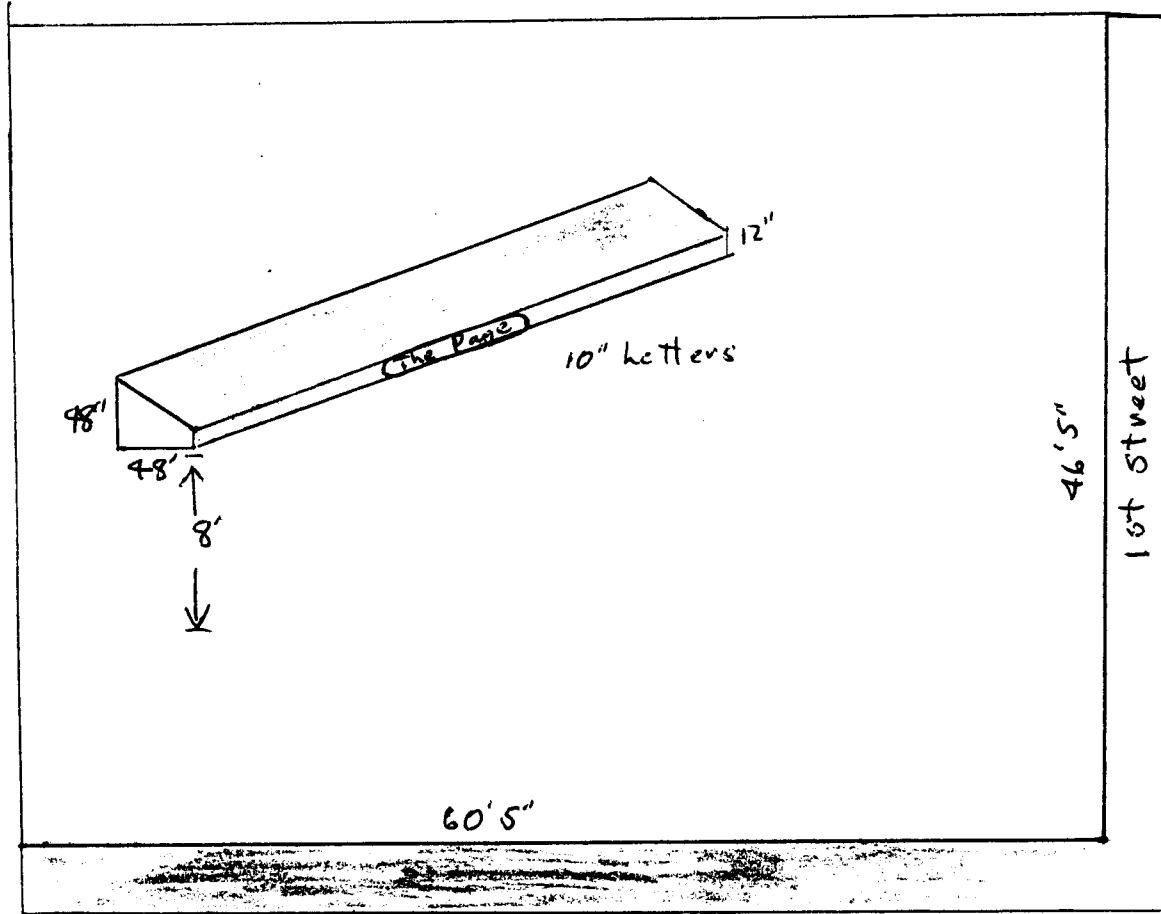

West Main