

DATE SUBMITTED: 11-20-92

PERMIT NO. 43581 ✓

FEE \$ 5.00

PLANNING CLEARANCE

GRAND JUNCTION COMMUNITY DEVELOPMENT DEPARTMENT

BLDG ADDRESS 2794 Cheyenne Dr.

SQ. FT. OF BLDG: ~~10~~ 1900 sq. F.T.

SUBDIVISION Reservation

SQ. FT. OF LOT: 15,250 approx.

FILING # _____ BLK # 8 LOT # 4

NO. OF FAMILY UNITS: 1

TAX SCHEDULE # 2945-244-04-020

NO. OF BUILDINGS ON PARCEL BEFORE THIS PLANNED CONSTRUCTION: 0

OWNER Richard Sroufe

USE OF EXISTING BUILDINGS: N/A

ADDRESS 2792 Cheyenne Dr.

DESCRIPTION OF WORK AND INTENDED USE: Construction of Residence + garage

TELEPHONE: 242-2444

REQUIRED: Two plot plans showing parking, landscaping, setbacks to all property lines, and all streets which abut the parcel.

FOR OFFICE USE ONLY

ZONE R5K-8

FLOODPLAIN: YES _____ NO

SETBACKS: FRONT 45' from CL

GEOLOGIC HAZARD: YES _____ NO

SIDE 5 REAR 15

CENSUS TRACT: 13 TRAFFIC ZONE: 80

MAXIMUM HEIGHT 32'

PARKING REQ'MT _____

LANDSCAPING/SCREENING REQUIRED: _____

SPECIAL CONDITIONS: _____

Modifications to this Planning Clearance must be approved, in writing, by this Department. The structure approved by this application cannot be occupied until a Certificate of Occupancy is issued by the Building Department (Section 307, Uniform Building Code).

Any landscaping required by this permit shall be maintained in an acceptable and healthy condition. The replacement of any vegetation materials that die or are in an unhealthy condition shall be required.

I hereby acknowledge that I have read this application and the above is correct, and I agree to comply with the requirements above. Failure to comply shall result in legal action.

Department Approval

Applicant Signature

11-20-92
Date Approved

11/20/92
Date

VALID FOR SIX MONTHS FROM DATE OF ISSUANCE (Section 9-3-2 D Grand Junction Zoning & Development Code)

MESA COUNTY DEVELOPMENT CLEARANCE

IN THE SPACE BELOW PLEASE NEATLY DRAW A SITE PLAN SHOWING THE FOLLOWING:

1. An outline of the PROPERTY LINES with dimensions. []
2. An outline of the PROPOSED STRUCTURE with dotted lines and dimensions of the PROPOSED STRUCTURE. []
3. The DISTANCE from the proposed structure to the front, rear, and side property lines (setbacks). []
4. All EASEMENTS OR RIGHTS-OF-WAYS on the property. []
5. All other STRUCTURES on the property. []
6. All STREETS adjacent to the property and street names. []
7. All existing and proposed DRIVEWAYS. []
8. An arrow indicating NORTH. []
9. Location of existing and/or PROPOSED PARKING and NUMBER OF SPACES. []

=====
 ANY OF THE ABOVE INFORMATION THE APPLICANT FAILS TO SHOW ON THE DRAWING WILL RESULT IN A DELAY OF OBTAINING THE DEVELOPMENT CLEARANCE.
 =====

ACCEPTED
 ANY CHANGE OF SETBACKS MUST BE APPROVED BY THE CITY PLANNING DEPT. IT IS THE APPLICANT'S RESPONSIBILITY TO PROPERLY LOCATE AND IDENTIFY EASEMENTS AND PROPERTY LINES.

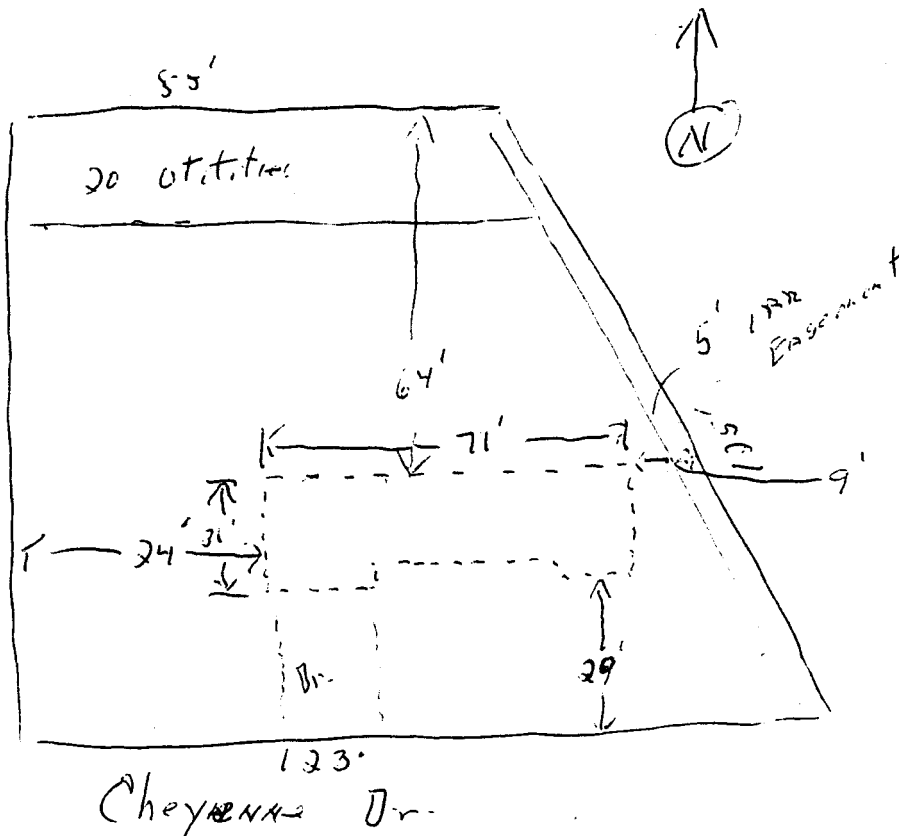

BY SIGNING BELOW, THE APPLICANT ACCEPTS THE RESPONSIBILITY TO PROPERLY LOCATE AND IDENTIFY ALL EASEMENTS, PROPERTY LINES, EXISTING AND PROPOSED STRUCTURES. IT IS FURTHER UNDERSTOOD THAT ANY CHANGE OF SETBACKS MUST BE APPROVED, IN WRITING BY THE PLANNING DIVISION.

APPLICANT'S SIGNATURE: [Signature] DATE: 11/20/97

APPROVED BY: _____ DATE: _____
 PLANNING DIVISION STAFF