

PERMIT # 40867 ✓
FEE \$ 500

2-5-92
PLANNING CLEARANCE
GRAND JUNCTION PLANNING DEPARTMENT

ADDRESS: 812 Rood Ave

SQ. FT. OF BLDG: 3000

DIVISION:

SQ. FT. OF LOT: 4000

BLK # LOT #

NUMBER OF FAMILY UNITS: 1

SCHEDULE NUMBER:

NUMBER OF BUILDINGS ON PARCEL BEFORE THIS PLANNED CONSTRUCTION:

2908-177-09-010

PROPERTY OWNER: Lee O Kelly

USE OF ALL EXISTING BUILDINGS:

ADDRESS: 1909 N. Road Front, Ca

Banner

PHONE: 858-7014

DESCRIPTION OF WORK AND INTENDED USE:
Commercial Awning

SUBMITTALS REQ'D: TWO (2) PLOT PLANS SHOWING PARKING, LANDSCAPING, SETBACKS TO ALL PROPERTY LINES, AND ALL STREETS WHICH ABUT THE PARCEL.

FOR OFFICE USE ONLY

ZONE: B-3

FLOODPLAIN: YES NO

MAXIMUM HEIGHT: Awning may be extend up to 4' into front yard setback

GEOLOGIC HAZARD: YES NO

PARKING SPACES REQ'D:

CENSUS TRACT #: 2

LANDSCAPING/SCREENING:

TRAFFIC ZONE: 41

SPECIAL CONDITIONS:

MODIFICATION TO THIS APPROVED PLANNING CLEARANCE MUST BE APPROVED, IN WRITING, BY THE DEPARTMENT. THE STRUCTURE APPROVED BY THIS APPLICATION SHALL NOT BE OCCUPIED UNTIL A CERTIFICATE OF OCCUPANCY (C.O.) IS ISSUED BY THE BUILDING DEPARTMENT (SECTION 307, UNIFORM BUILDING CODE.)

LANDSCAPING REQUIRED BY THIS PERMIT SHALL BE MAINTAINED IN AN ACCEPTABLE HEALTHY CONDITION. THE REPLACEMENT OF ANY VEGETATION MATERIALS THAT DIE OR ARE IN AN UNHEALTHY CONDITION SHALL BE REQUIRED.

HEREBY ACKNOWLEDGE THAT I HAVE READ THIS APPLICATION AND THE ABOVE IS CORRECT AND I AGREE TO COMPLY WITH THE REQUIREMENTS ABOVE. FAILURE TO COMPLY SHALL RESULT IN LEGAL ACTION.

APPROVED BY: [Signature] 2-5-92

[Signature]
SIGNATURE

PURCHASE ORDER NO. _____ DATE: 1-31-92

NAME: Mountain Message PHONE: _____

ADDRESS: _____ QUOTE (if any) _____

PROMISED BY: _____ Estimate _____ actual _____

INSTRUCTIONS: Sunbrella - Forest Green #4637 - 6" Valance - Same Pattern
Trim - Bright White as blue Dome in office

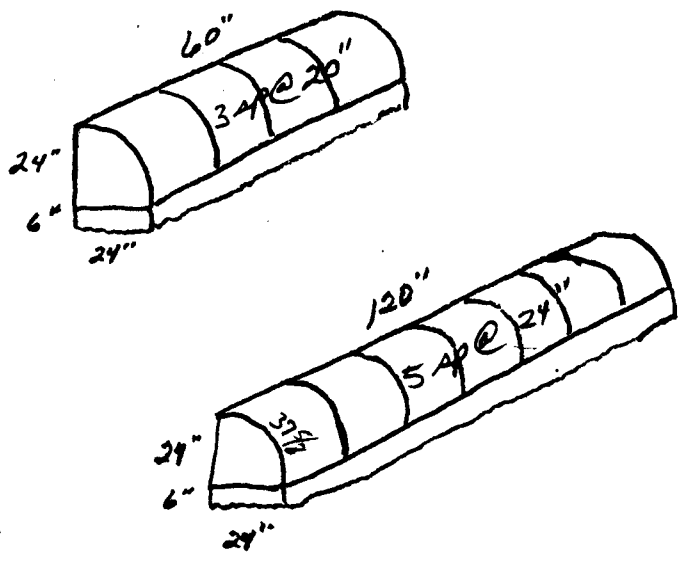

Operator _____
Material & Hardware Used _____

Notified _____
Inv. No. _____

Total Time _____
Total Material _____
City Tax _____
County Tax _____
State Tax _____