

The
FORD SUBDIVISION.
 Mesa County Colorado

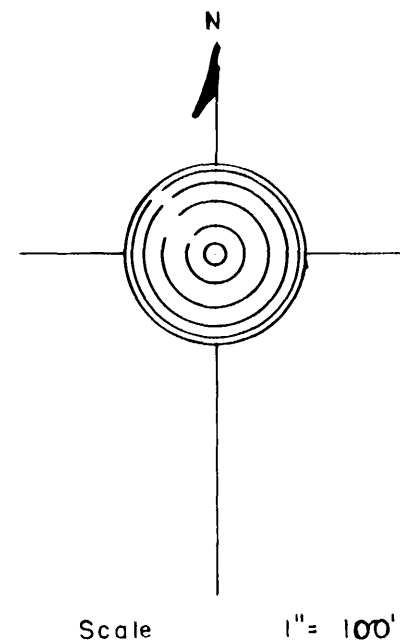

I certify that this is a true and correct plat of the following described land and the subdivision thereof

Roy L. George
 Registered Surveyor

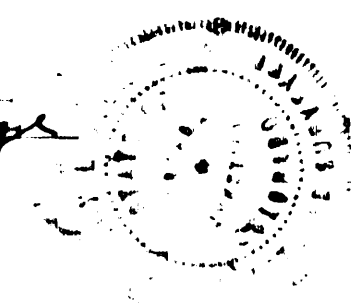

KNOW ALL MEN BY THESE PRESENTS: That C. C. Ford Edna Florence Ford and Lyman H. Ford being the owners of the following described land towit: The W 1/2 E 1/2 SE 1/4 SE 1/4 and beginning at the SW corner of the E 1/2 E 1/2 SE 1/4 SE 1/4 thence N 180' E 100' S 180' W 100' to beginning also the North 30 feet of the said E 1/2 SE 1/4 SE 1/4 in section 8 T 1 S R 1 E Ute Meridian. Have made the Ford Subdivision thereof and do hereby dedicate the streets and easements shown hereon to the use of the public forever.

C. C. Ford
Edna Florence Ford
Lyman H. Ford

STATE OF COLORADO } SS
 County of Mesa

The foregoing instrument was acknowledged before me this 26th day of November 1948 by C. C. Ford Edna Florence Ford and Lyman H. Ford.
 My commission expires Feb. 14, 1949.

W. A. ...
 Notary Public