

SUMMIT VIEW RIDGE

DEDICATION

That the undersigned, Casa Tiara Development, Inc., is the owners of that real property located in the NE 1/4 NE 1/4 of Section 15, Township 2 North, Range 1 East of the Ute Meridian, Mesa County, Colorado, as described in Book 2928 at Page 176 and 177 of the records of the Mesa County Clerk and Recorder's Office, more particularly described as follows:
KNOW ALL MEN BY THESE PRESENTS:

Beginning at a point which is S85°50'11"W 394.04 feet from the northeast corner of Section 15, then along the following ten courses:
1. N89°47'50"W 557.00 feet along a line 30.00 feet south of and parallel to the north line of the northeast quarter of the northeast quarter;
2. S00°00'21"W 1287.95 feet along a line 950 feet west of and parallel to the east line of the northeast quarter of the northeast quarter;
3. S89°49'03"E 301.66 feet along the south line of the northeast quarter of the northeast quarter;
4. N00°00'10"E 658.92 feet along a line 6.6 feet east of and parallel to the east line of the east half of the northeast quarter of the northeast quarter;
5. S89°48'26"E 450.37 feet along the south line of the north half of the east half of the northeast quarter of the northeast quarter;
6. N00°00'21"E 223.24 feet along a line 198.00 feet west of and parallel to the east line of the northeast quarter of the northeast quarter;
7. N89°47'50"W 100.00 feet along a line 435.6 feet south of and parallel to the north line of the northeast quarter of the northeast quarter;
8. N00°00'21"E 252.19 feet along a line 298.00 feet west of and parallel to the east line of the northeast quarter of the northeast quarter;
9. N89°47'50"W 95.00 feet along a line 183.41 feet south of and parallel to the north line of the northeast quarter of the northeast quarter;
10. N00°00'21"E 153.41 feet along a line 298.00 feet west of and parallel to the east line of the northeast quarter of the northeast quarter to the beginning.
The area of the parcel as described is 14.15 acres.
The basis for bearings is assumed N89°47'50"W 1310.02 feet between Mesa County Survey Monuments No 12-1 and No 991 respectively for the northeast corner and the east sixteenth corner on the north boundary of Section 15.

That said owner has caused the real property to be laid out and surveyed as SUMMIT VIEW RIDGE, a land division of a part of the County of Mesa, in the State of Colorado.

That said owner does hereby dedicate and set apart real property as shown and labeled on the accompanying plat.

All streets and roads for the use of the public forever:

All Multi-Purpose Easements shown hereon are hereby dedicated to the County of Mesa for the use of County approved utilities and public providers as perpetual, non-exclusive easements for the installation, operation, maintenance and repair of utilities and appurtenances.

All Irrigation and Drainage Easements shown hereon are hereby granted to an association if formed now or in the future for the benefit of the owners, or if not, to the owners of the lots and tracts hereby platted as undivided interests, not subject to partition, as perpetual easements for the installation, operation, maintenance and repair of irrigation systems, drainage facilities for the conveyance of runoff water which originated within the area hereby platted or from upstream areas through natural or man-made facilities above or below ground, to supply and drain irrigation water.

Tract B, shown hereon is hereby granted to an association, if formed now or in the future for the benefit of the owners, or if not, to the owners of the lots hereby platted as undivided interests, not subject to partition, for the use of the public for purposes including but not limited to, ingress and egress for pedestrians and other non-motorized forms of transportation for commuting and recreational purposes.

Tract A, C and D, shown hereon is hereby granted to an association, if formed now or in the future for the benefit of the owners, or if not, to the owners of the lots hereby platted as undivided interests, not subject to partition, for (a) the conveyance or storage of irrigation water and storm water through natural or man-made facilities above or below ground, (b) the maintenance and repair of irrigation systems, subject to the various easements dedicated and granted on this Final Plat.

That all expenses for street paving or the installation of utilities referred to above, shall be furnished by the seller or the purchaser, not by the County of Mesa.

IN WITNESS WHEREOF said owner has caused his name to be hereon subscribed this 12 day of December, 2001 A.D., 2001

PLAT NOTES

Pursuant to C.R.S. 24-68-101 et seq., and Chapter 1.10 of the 2000 Mesa County Land Development Code, a site specific development plan has been approved by Mesa County for SUMMIT VIEW RIDGE and shall result in a vested right for a period of three years from December 21, 2001.

RIGHT TO FARM ACT NOTICE: This development is located in an agricultural area. It is hereby recognized that agricultural operations may continue pursuant to C.R.S. 35-3.5-101 et seq.

NOTICE: According to Colorado law you must commence any legal action based upon any defect in the survey within three years after you first discover such defect. In no event may any action based upon and defect in this survey be commenced more than ten years from the date of the certification / statement shown hereon.

BOARD OF COUNTY COMMISSIONERS CERTIFICATE

Approved this 14th day of December A.D. 2001, by the Board of County Commissioners of the County of Mesa, State of Colorado.

Kathryn A. Hall
Chairman

CLERK AND RECORDER'S CERTIFICATE

I hereby certify that this instrument was filed for recording in my office at 1:25 o'clock P.M., this 14th day of December A.D. 2001, and is duly recorded in Plat Book No. 18 at page 295 & 296.
Reception No. 2030994 Fees 20.00 Drawer No. 1172

Case Zinke
Deputy

Monica Jell
Clerk and Recorder

LIENHOLDER ACCEPTANCE: *Kent Shettler*
The Bank of Colorado
Kent Shettler - Vice President

STATE OF COLORADO)
COUNTY OF MESA) ss
The forgoing instrument was acknowledged before me this 13 day of December A.D., 2001 by Kent Shettler, Vice President - The Bank of Colorado.
Witness my hand and official seal: *Carol Ann M. Smith*
Address: 131 W. Bowen #65 Palisade CO 81350
My commission expires: 4-30-05

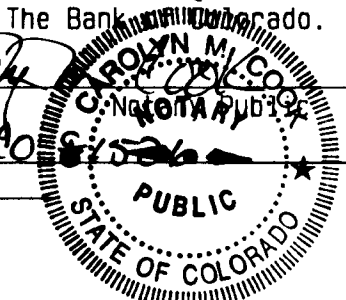

Mansel L. Zeck
Casa Tiara Development, Inc.
Mansel L. Zeck, President

STATE OF COLORADO)
COUNTY OF MESA) ss
The forgoing instrument was acknowledged before me this 13 day of December A.D., 2001 by Casa Tiara Development, Inc., Mansel L. Zeck, President.
Witness my hand and official seal: *Carol Ann M. Smith*
Address: 131 W. Bowen #65 Palisade CO 81350
My commission expires: 4-30-05

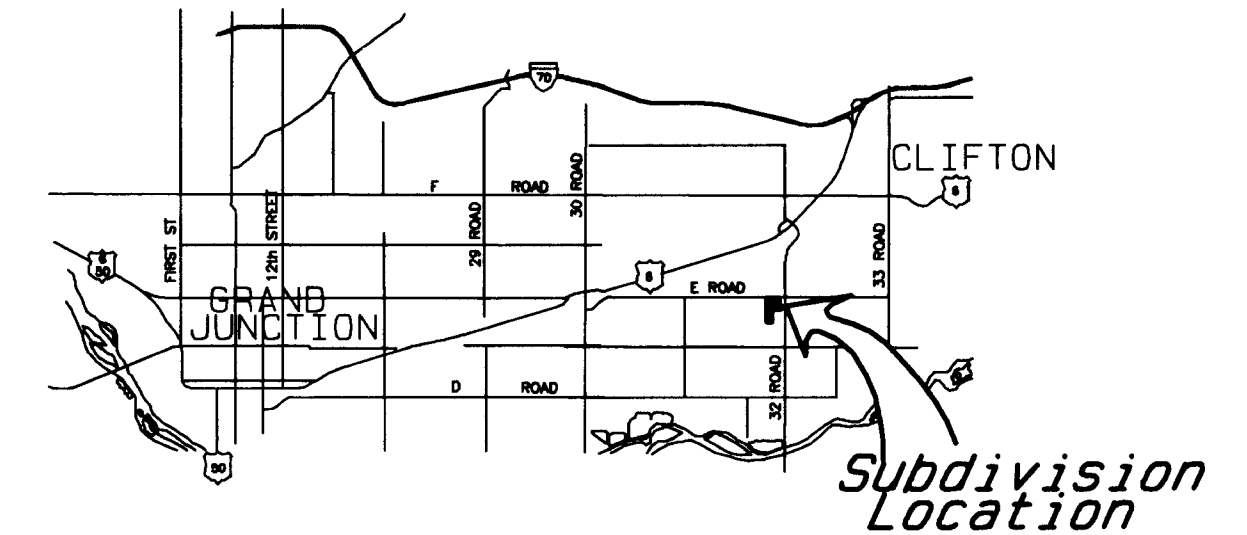
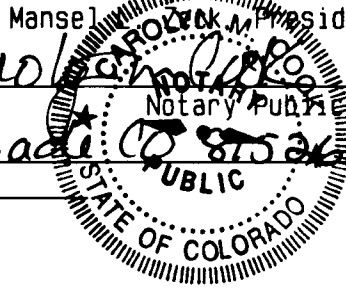

VICINITY MAP - N.T.S.

TRACT DESCRIPTION

TRACT A - RETENTION AREA	= 8538 SQ. FT.
TRACT B - PEDESTRIAN PATH	= 896 SQ. FT.
TRACT C - COMMON AREA	= 5529 SQ. FT.
TRACT D - COMMON AREA	= 2345 SQ. FT.

AREA SUMMARY

Ded. Road R.O.W.	3.31 Acres = 23.39%
Tracts A - D	0.40 Acres = 02.81%
Lots	10.44 Acres = 73.80%
TOTAL	14.15 Acres = 100%

SURVEYOR'S STATEMENT

I, Steven L. Hagedorn, a registered Professional Land Surveyor in the State of Colorado, do hereby state that this survey was performed by me or under my direct responsibility, supervision, and checking. That no title search was made by me to determine ownership, easements or right-of-ways recorded or unrecorded, except as shown hereon.

Steven L. Hagedorn
24306
12-13-01
PROFESSIONAL LAND SURVEYOR
STATE OF COLORADO

SUMMIT VIEW RIDGE LOCATED IN THE NE 1/4 NE 1/4, SEC. 15, T1S, R1E, U1M					
D H SURVEYS INC. 118 OURAY AVE. - GRAND JUNCTION, CO. (970) 245-8749					
Designed By	M.W.D.	Checked By	A.V.P.	Job No.	280-01-14
Drawn By	TMODEL	Date	DEC. 2001	Sheet	1 OF 2

SUMMIT VIEW RIDGE

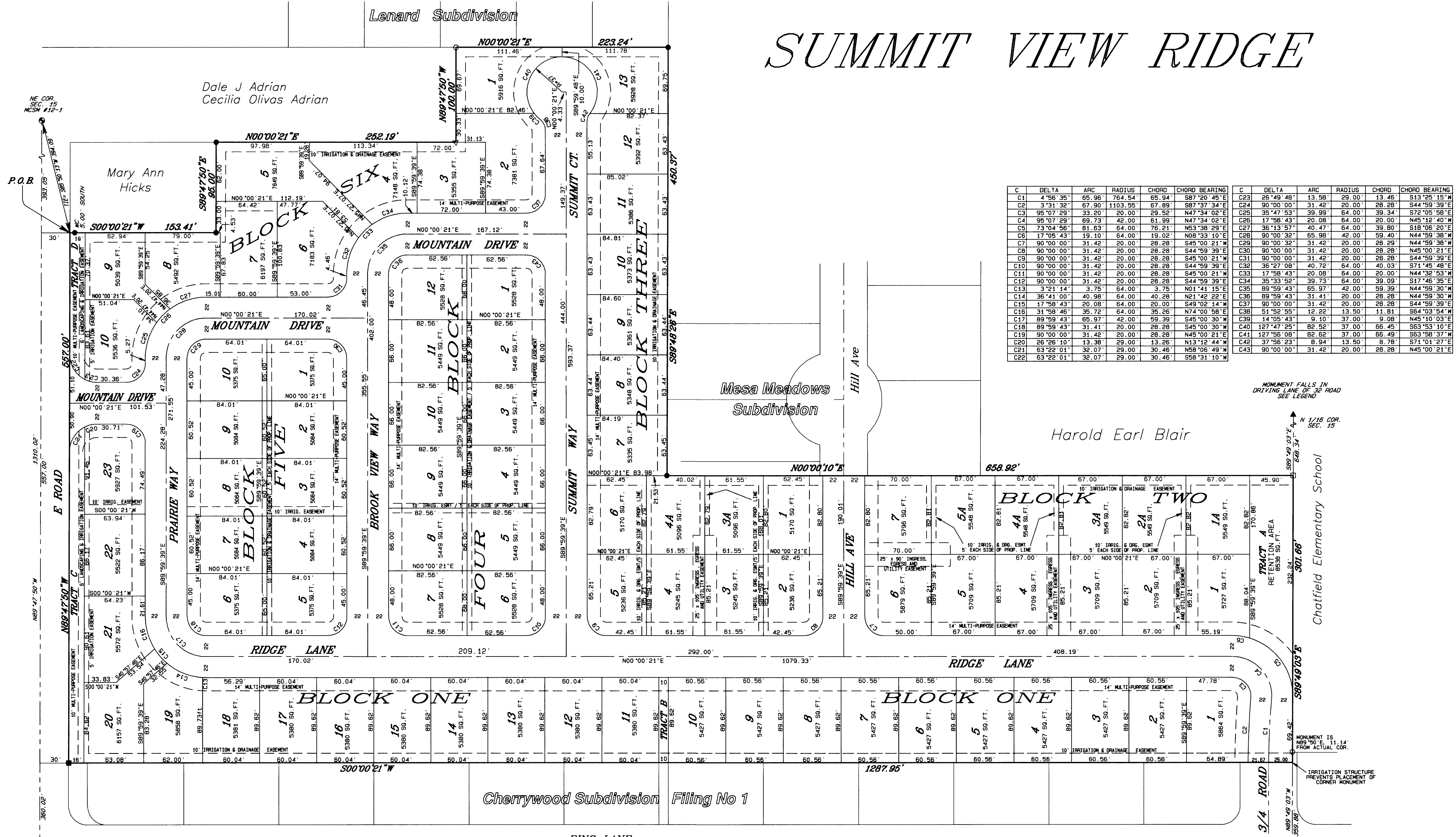

C	DELTA	ARC	RADIUS	CHORD	CHORD BEARING	C	DELTA	ARC	RADIUS	CHORD	CHORD BEARING
C1	4°56'35"	65.96'	764.54'	65.94'	S87°20'45"E	C23	26°49'48"	13.58'	29.00'	13.46'	S13°25'15"W
C2	3°31'32"	67.90'	1103.55'	67.89'	S87°37'34"E	C24	90°00'00"	31.42'	20.00'	28.28'	S44°59'39"E
C3	95°07'29"	33.20'	20.00'	29.52'	N47°34'02"E	C25	35°47'53"	39.99'	64.00'	39.34'	S72°05'58"E
C4	95°07'29"	69.73'	42.00'	61.99'	N47°34'02"E	C26	17°58'43"	20.08'	64.00'	20.00'	N45°12'40"W
C5	73°04'58"	81.53'	64.00'	76.21'	N63°38'29"E	C27	35°13'57"	40.47'	64.00'	39.80'	S18°06'20"E
C6	17°05'43"	19.10'	64.00'	19.02'	N08°33'10"E	C28	90°00'32"	65.98'	42.00'	59.40'	N44°59'38"W
C7	90°00'00"	31.42'	20.00'	28.28'	S45°00'21"W	C29	90°00'00"	31.42'	20.00'	28.28'	N44°59'38"W
C8	90°00'00"	31.42'	20.00'	28.28'	S44°59'39"E	C30	90°00'00"	31.42'	20.00'	28.28'	N45°00'21"E
C9	90°00'00"	31.42'	20.00'	28.28'	S45°00'21"W	C31	90°00'00"	31.42'	20.00'	28.28'	S44°59'39"E
C10	90°00'00"	31.42'	20.00'	28.28'	S44°59'39"E	C32	36°27'08"	40.72'	64.00'	40.03'	S71°45'48"E
C11	90°00'00"	31.42'	20.00'	28.28'	S45°00'21"W	C33	17°58'43"	20.08'	64.00'	20.00'	N44°32'53"W
C12	90°00'00"	31.42'	20.00'	28.28'	S44°59'39"E	C34	35°13'52"	39.73'	64.00'	39.09'	S17°46'35"E
C13	3°21'14"	3.75'	64.00'	3.75'	N01°41'15"E	C35	89°59'43"	65.97'	42.00'	59.39'	N44°59'30"W
C14	36°41'00"	40.98'	64.00'	40.28'	N21°42'22"E	C36	89°59'43"	31.41'	20.00'	28.28'	N44°59'30"W
C15	17°58'43"	20.08'	64.00'	20.00'	S49°02'14"W	C37	90°00'00"	31.42'	20.00'	28.28'	S44°59'39"E
C16	31°58'46"	35.72'	64.00'	35.26'	N74°00'58"E	C38	51°52'55"	12.22'	13.50'	11.81'	S64°03'54"W
C17	89°59'43"	65.97'	42.00'	59.39'	S45°00'30"W	C39	14°05'43"	9.10'	37.00'	9.08'	N45°10'03"E
C18	89°59'43"	31.41'	20.00'	28.28'	S45°00'30"W	C40	127°47'25"	82.52'	37.00'	65.45'	S63°53'10"E
C19	90°00'00"	31.42'	20.00'	28.28'	N45°00'21"E	C41	127°56'08"	82.62'	37.00'	65.49'	S63°58'37"W
C20	26°26'10"	13.38'	29.00'	13.26'	N13°12'44"W	C42	37°56'23"	8.94'	13.50'	8.78'	S71°01'27"E
C21	63°22'01"	32.07'	29.00'	30.46'	N58°06'49"W	C43	90°00'00"	31.42'	20.00'	28.28'	N45°00'21"E
C22	63°22'01"	32.07'	29.00'	30.46'	S58°31'10"W						

Dale J Adrian
Cecilia Olivas Adrian

Mary Ann Hicks

Mesa Meadows
Subdivision

Harold Earl Blair

Chatfield Elementary School

Cherrywood Subdivision Filling No 1

- LEGEND**
- MESA COUNTY SURVEY MARKER
 - ⊗ B. L. M. ALUM. MONUMENT 1988
 - ▲ FD PK NAIL, SET TWO REFERENCE MONUMENTS (RM) PURSUANT TO THE COLORADO REVISED STATUTES
 - FD, #5 REBAR W/PLASTIC CAP MARKED STRONG PE8LS 11441
 - FD, #5 REBAR IN CONCRETE
 - SET 2" ALUM. CAP STAMPED D H SURVEYS LS 20677
 - FD, #5 REBAR W/PLASTIC CAP MARKED LUKE LS 14115
 - FD, #5 REBAR W/1.5" ALUM. CAP STAMPED LS 15598
 - FD, #5 REBAR (BENT)
 - ▽ RE-SET W/2" ALUM. CAP STAMPED D H SURVEYS LS 20677
 - FD #4 REBAR, REPLACED W/2" ALUM. CAP STAMPED D H SURVEYS LS 20677
- ALL EXTERIOR CORNERS SET IN CONCRETE

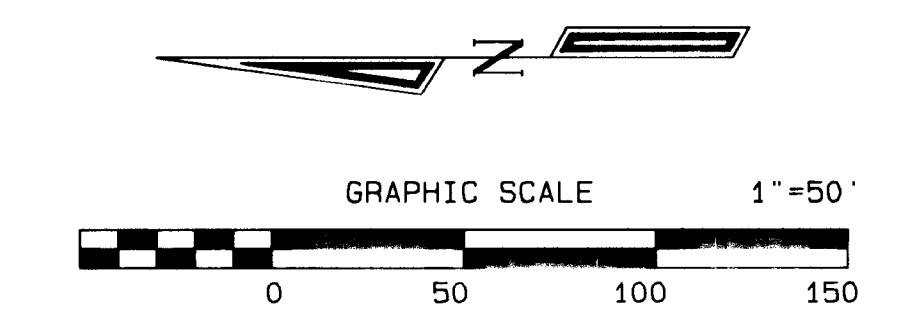

SUMMIT VIEW RIDGE
LOCATED IN THE
NE 1/4 NE 1/4, SEC. 15, T1S, R1E, U.M.

D H SURVEYS INC.
118 OURAY AVE. - GRAND JUNCTION, CO.
(970) 245-8749

Designed By	M.W.D.	Checked By	M.W.D.	Job No.	280-01-14
Drawn By	TMODEL	Date	DEC. 2001	Sheet	2 OF 2