

KOHLS SUBDIVISION

BEING A REPLAT OF LOT 1A OF REPLAT OF MESA VILLAGE SUBDIVISION

DEDICATION

KNOW ALL MEN BY THESE PRESENTS:

That WTN CoEx I, LLC is the owner of that real property located in part of the SW 1/4 of Section 4, Township 1 South, Range 1 West of the Ute Meridian, Mesa County, Colorado, being more particularly described as follows:
 Lot 1A in Replat of Mesa Village Subdivision, (Plat Book 15, Pages 37-39), in the W 1/2 SW 1/4 of Section 4, Township 1 South, Range 1 West, of the Ute Meridian, City of Grand Junction, Mesa County, Colorado, EXCEPT right-of-way as described in Book 2940 Page 884.

That said owner has caused the real property to be laid out and platted as Kohls Subdivision, a subdivision of a part of the City of Grand Junction, Colorado. That said owner does hereby dedicate and set apart real property as shown and labeled as the accompanying plat of Kohls Subdivision as follows:
 All Streets and Rights-of-way are dedicated to the City of Grand Junction for the use of the public forever.

All Multi-Purpose and Utility Easements are dedicated to the City of Grand Junction for the use of the public utilities as perpetual easements for the installation, operation, maintenance and repair of utilities and appurtenances thereto including, but not limited to electric lines, cable TV lines, natural gas pipelines, sanitary sewer lines, water lines, telephone lines, and also for the installation and maintenance of traffic control facilities, street lighting, street trees and grade structures.

All Tracts/Easements include the right of ingress and egress on, along, over, under, through and across by the beneficiaries, their successors, or assigns, together with the right to trim remove interfering trees and brush, and in Drainage and Detention/Retention easements or tracts, the right to dredge: provided however, that the beneficiaries/owners of said lots or tracts hereby platted shall not burden or overburden said easements by erecting or placing any improvements thereon which may impede the use of the easement and/or prevent the reasonable ingress and egress to and from the easement.

IN WITNESS WHEREOF, said owner WTN CoEx I, LLC, has caused their name to be hereunto subscribed this 28th day of February, A.D., 2006.

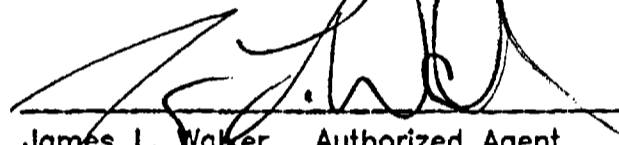
 James L. Walker, Authorized Agent

NOTARY PUBLIC CERTIFICATION

STATE OF COLORADO } ss
 COUNTY OF MESA }

The foregoing instrument was acknowledged before me by James L. Walker this 28 day of February, A.D., 2006.
 Witness my hand and official seal:

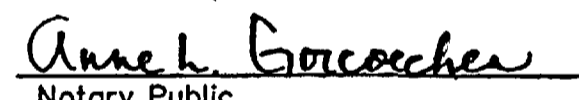
 Anne L. Goicoechea
 Notary Public

My Commission Expires 10/11/2009

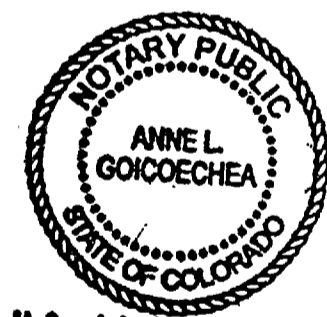

LIENHOLDERS RATIFICATION OF PLAT

The undersigned, hereby certifies that it is a holder of a security interest upon the property hereon described and does hereby join in and consent to the dedication of the land described in said dedication by the owners thereof and agrees that its security interest which is recorded in Book 4048 at Page 166, (affects Deed of Trust recorded in Book 3647, Page 391) and Book 4048 at Page 158 of the Public Records of Mesa County, Colorado shall be subordinated to the dedications shown hereon.

IN WITNESS WHEREOF, the said individual(s) have caused these presents to be signed this 28th day of February, 2006.

 Jeff A. Berkley, President
 Alliance Bank

NOTARY PUBLIC CERTIFICATION

STATE OF KANSAS } ss
 COUNTY OF SHAWNEE }

The foregoing instrument was acknowledged before me by Jeff A. Berkley this 28th day of February, A.D., 2006.
 Witness my hand and official seal:

 Angela L. Wild
 Notary Public

My Commission Expires 2/24/09

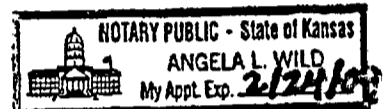

CLERK AND RECORDER'S CERTIFICATE

STATE OF COLORADO } ss
 COUNTY OF MESA }

I hereby certify that this instrument was filed in my office at 3:32 o'clock P.M., March 2 A.D., 2006, and was duly recorded in Book No. 4105 Page No. 386-388, Reception No. 2304708, Drawer No. RR-118

Clerk and Recorder

CITY OF GRAND JUNCTION APPROVAL

This plat of Kohls Subdivision, a subdivision of a part of the City of Grand Junction, County of Mesa, State of Colorado, is approved and accepted this 28 day of February, A.D., 2006.

 City Manager

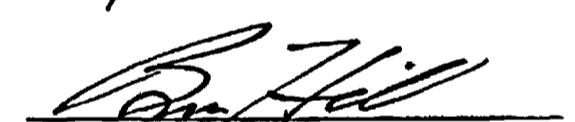
 President of City Council

TITLE CERTIFICATION

STATE OF COLORADO
 COUNTY OF MESA

We, Transnation Title Insurance Company, a title insurance company, as duly licensed in the State of Colorado, hereby certify that we have examined the title to the hereon described property, that we find the title to the property is vested to WTN CoEx I LLC; that the current taxes have been paid; that all mortgages not satisfied or released of record nor otherwise terminated by law are shown hereon and that there are no other encumbrances of record; that all easements, reservations and rights of way of record are shown hereon.

Date: 2-23-06

By: Debra M. Blanchette side officer
 Name and Title
 Transnation Title Insurance Company

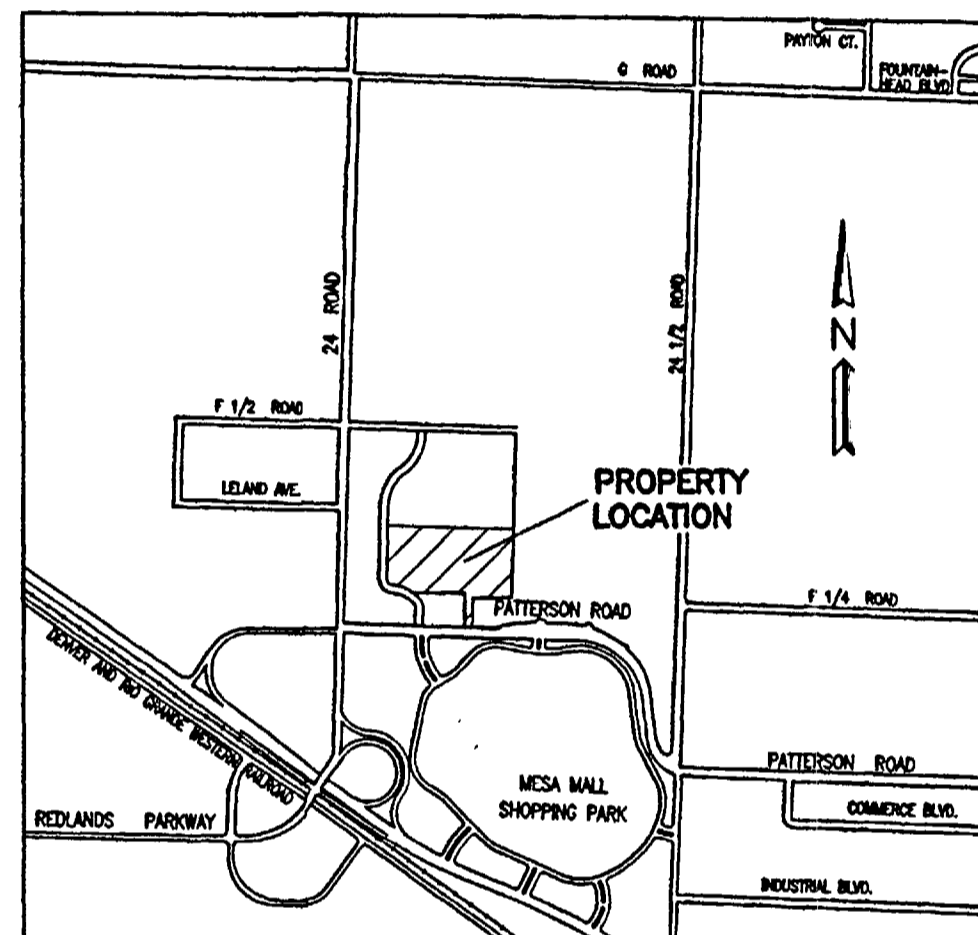

VICINITY MAP
 NOT TO SCALE

FOR CITY USE ONLY

Associated Recorded documents

Book	Page	Type
4105	359	Release & Termination of Vesting Agreement Rights
4105	363	Grant of Cross Access Easement
4105	368	Grant of Cross Access Easement
4105	373	Grant of Cross Access Easement
4105	378	Parking Easement

NOTICE: ACCORDING TO COLORADO LAW YOU MUST COMMENCE ANY LEGAL ACTION BASED UPON ANY DEFECT IN THIS SURVEY WITHIN THREE YEARS AFTER YOU FIRST DISCOVER SUCH DEFECT. IN NO EVENT, MAY ANY ACTION BASED UPON ANY DEFECT IN THIS SURVEY BE COMMENCED MORE THAN TEN YEARS FROM THE DATE OF CERTIFICATION SHOWN HEREON.

SURVEYOR'S CERTIFICATION

I hereby certify that this plat represents a field survey completed under my direct supervision during August 2005, and that both have been completed according to the standards of practice and the laws of the State of Colorado, and are correct to the best of my knowledge.

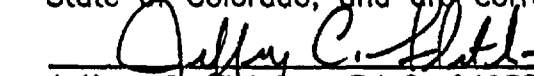
 Jeffrey Q. Fletcher, P.L.S. 24953
 Date: FEB. 24, 2006

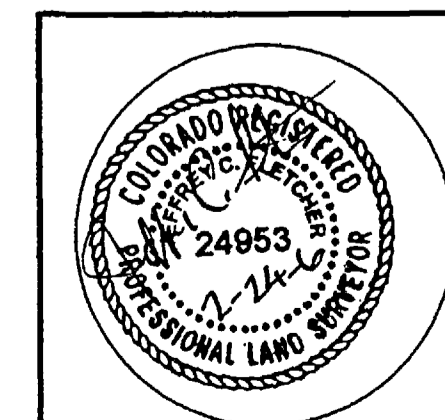

Prepared for: WTN CoEx I, LLC
 A Colorado limited liability company

KOHLS SUBDIVISION
 SW 1/4 SECTION 4
 T1S, R1W, UTE MERIDIAN
 MESA COUNTY, COLORADO

High Desert Surveying, LLC
 2591 B 3/4 Road, Grand Jct., CO 81503
 970-254-8649 Fax 970-255-7047

SUR. BY: JT	DRAWN BY: CW
JOB NO. 05-157	SHEET 1 OF 3
DATE: OCTOBER 7, 2005	

KOHLS SUBDIVISION

BEING A REPLAT OF LOT 1A OF REPLAT OF MESA VILLAGE SUBDIVISION

NOTES

1. Basis of bearings is from GPS observations using the Mesa County SIMS LCS. The West line of the NW 1/4 SW 1/4 of Section 4, Township 1 South, Range 1 West of the Ute Meridian, Mesa County, Colorado bears N 00°01'17"W a distance of 1320.02 feet. The S 1/16 corner between Section 4 and Section 5 is a MCSM and the 1/4 corner between Section 4 and Section 5 is a BLM aluminum cap.
2. Easement and Title information provided by Transnation Title Insurance Company, Policy No. A52-0020657, dated Sept. 29, 2005.
3. Property corners located during this survey that were within 0.25 feet of the calculated point were accepted as being 'in position'.

ABBREVIATIONS

- GPS = GLOBAL POSITIONING SYSTEM
 N = NORTH
 S = SOUTH
 E = EAST
 W = WEST
 LCS = LOCAL COORDINATE SYSTEM
 T = TOWNSHIP
 R = RANGE
 SQ. FT. = SQUARE FEET
 PLS = PROFESSIONAL LAND SURVEYOR
 NO. = NUMBER
 NW = NORTHWEST
 BLM = BUREAU OF LAND MANAGEMENT
 SW = SOUTHWEST
 MCSM = MESA COUNTY SURVEY MARKER
 ROW = RIGHT OF WAY
 SIMS = SURVEY INFORMATION MANAGEMENT SYSTEM

LINE	BEARING	DISTANCE
L1	S 89°51'15" W	30.00'
L2	N 42°20'06" W	30.27'
L3	N 87°46'33" W	34.39'
L5	S 00°06'55" E	17.00'
L6	N 00°06'55" W	34.90'
L7	N 51°54'39" E	128.40'
L8	S 89°57'10" E	45.41'
L9	N 00°00'00" W	38.08'
L10	N 89°53'07" E	89.57'
L11	S 00°07'29" E	93.46'
L12	S 00°06'55" E	115.92'
L12	S 00°06'55" E	115.92'
L13	S 19°27'22" E	31.13'
L14	N 00°03'55" W	62.04'
L15	N 19°10'32" E	31.04'
L16	N 89°51'15" E	32.24'
L17	S 89°51'15" W	15.16'
L18	S 89°51'15" W	14.98'
L19	N 89°51'15" E	7.64'
L20	N 42°20'06" W	33.99'
L21	S 87°46'33" E	33.87'

CURVE	RADIUS	ARC LENGTH	CHORD LENGTH	CHORD BEARING	DELTA ANGLE
C1	124.00'	92.87'	80.71'	S 21°34'16" E	42°54'42"
C2	274.00'	17.01'	17.01'	N 01°48'56" E	03°33'28"
C3	274.00'	247.81'	238.45'	N 29°30'14" E	51°49'07"
C4	326.00'	310.36'	298.77'	S 28°08'22" W	54°32'51"
C5	55.00'	10.77'	10.75'	N 06°28'28" E	11°13'02"
C6	148.51'	31.22'	31.16'	S 05°58'45" W	12°12'29"
C7	720.00'	197.88'	197.35'	S 82°12'30" E	15°45'16"
C8	880.00'	72.99'	72.96'	N 76°42'25" W	04°45'07"

AREA SUMMARY

LOT 1	=	7.31 Acres	35%
LOT 2	=	4.81 Acres	23%
LOT 2 REPLAT	=	8.97 Acres	42%
TOTAL	=	21.09 Acres	100%

Prepared for: WTN CoEx I, LLC
 A Colorado limited liability company

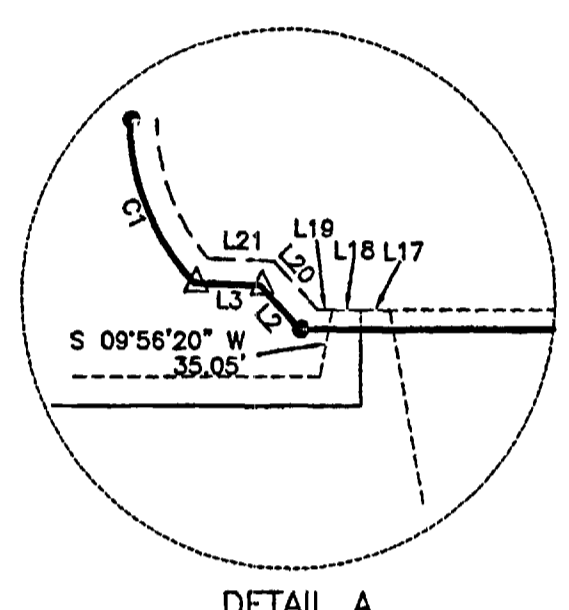
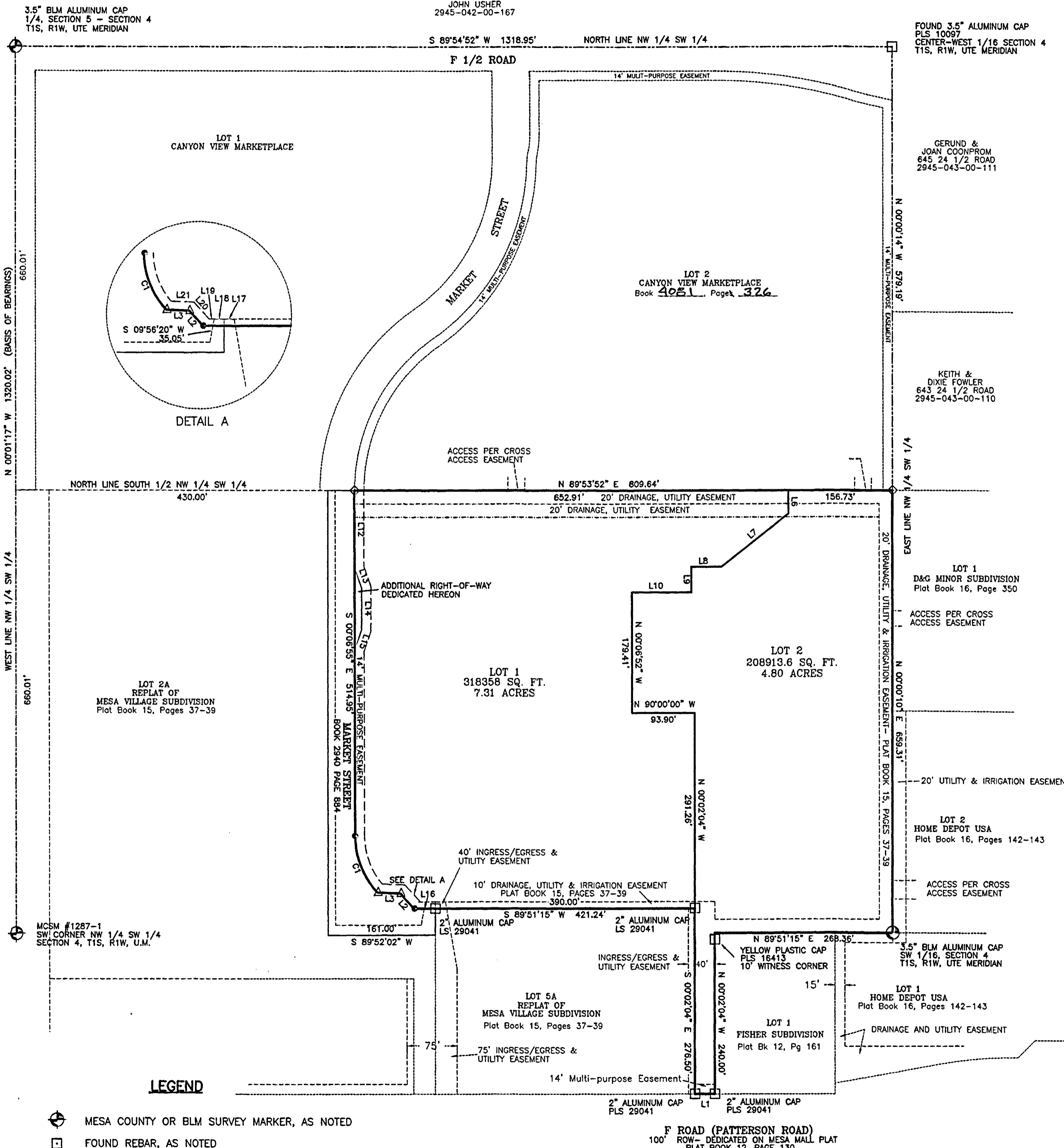

- ### LEGEND
- ⊕ MESA COUNTY OR BLM SURVEY MARKER, AS NOTED
 - FOUND REBAR, AS NOTED
 - ◇ FOUND REBAR, LS 24953
 - SET ALUMINUM CAP ON No. 5 REBAR, PLS 24953
 - △ SET CONCRETE NAIL WITH ALUMINUM DISK, PLS 24953

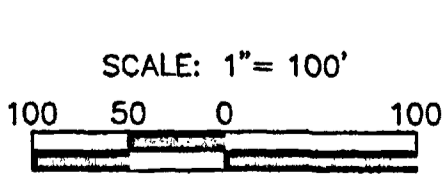

NOTICE: ACCORDING TO COLORADO LAW YOU MUST COMMENCE ANY LEGAL ACTION BASED UPON ANY DEFECT IN THIS SURVEY WITHIN THREE YEARS AFTER YOU FIRST DISCOVER SUCH DEFECT. IN NO EVENT, MAY ANY ACTION BASED UPON ANY DEFECT IN THIS SURVEY BE COMMENCED MORE THAN TEN YEARS FROM THE DATE OF CERTIFICATION SHOWN HEREON.

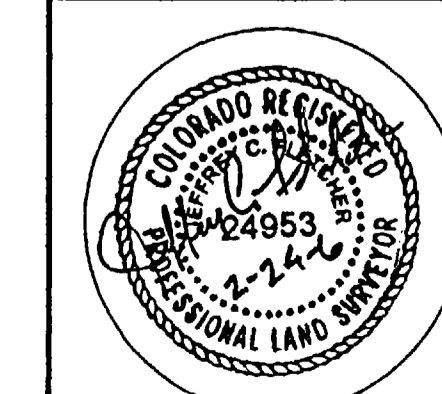

KOHLS SUBDIVISION
 SW 1/4 SECTION 4
 T1S, R1W, UTE MERIDIAN
 MESA COUNTY, COLORADO

High Desert Surveying, LLC
 2591 B 3/4 Road, Grand Jct., CO 81503
 970-254-8649 Fax 970-255-7047

SUR. BY: JT	DRAWN BY: CW/JF
JOB NO. 05-157	SHEET 2 OF 2
DATE: OCT. 7, 2005	REV: JAN. 23, 2006

KOHL'S SUBDIVISION

CROSS ACCESS EASEMENT

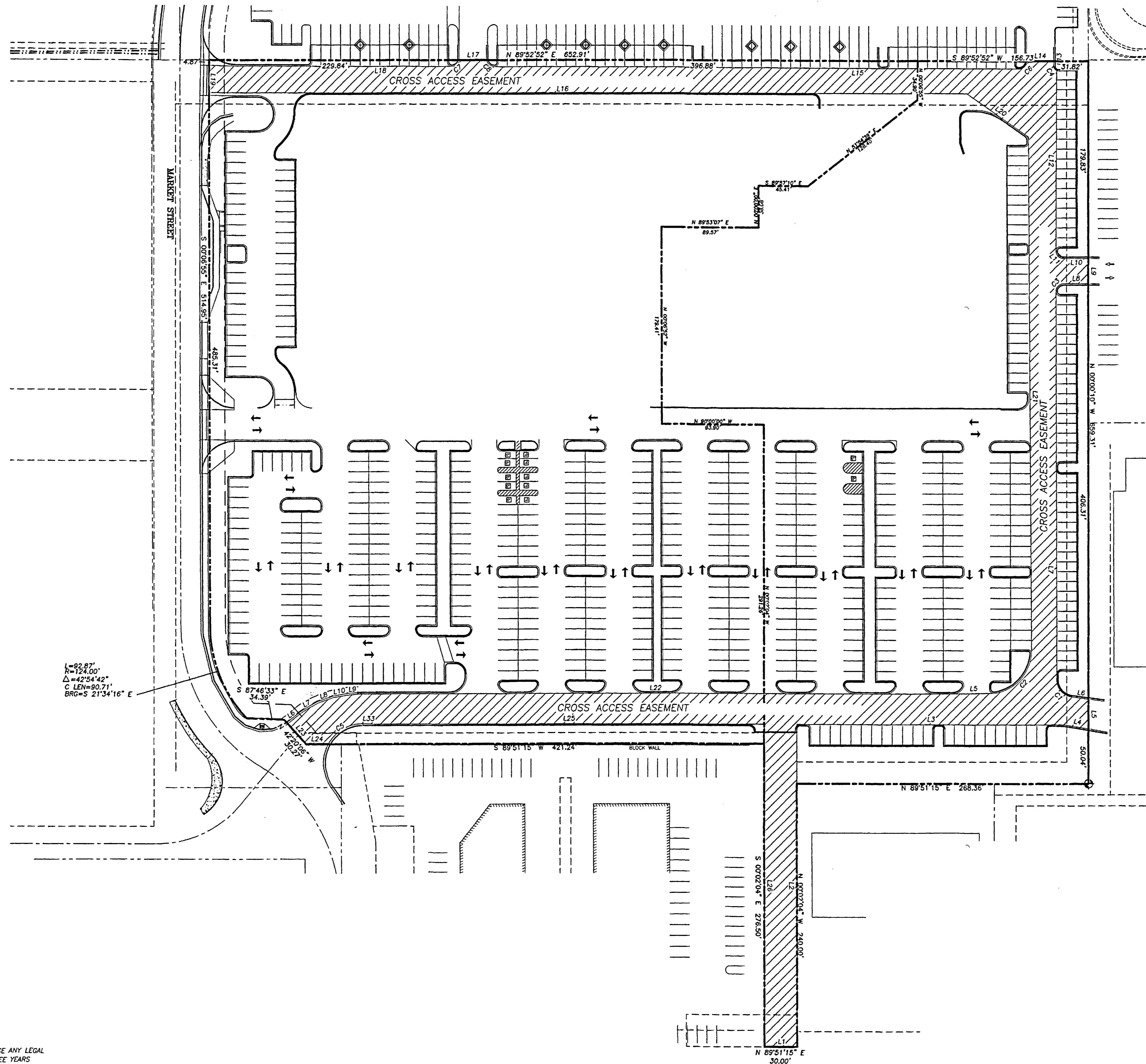

LINE	BEARING	DISTANCE
L1	S 89°51'15" W	30.00'
L2	S 00°02'04" E	294.28'
L3	S 89°56'37" W	246.46'
L4	S 80°40'09" E	22.23'
L5	S 00°00'03" E	27.48'
L6	S 82°38'25" E	15.28'
L7	S 00°06'55" E	189.50'
L8	S 89°53'00" W	22.80'
L9	S 00°00'03" E	23.00'
L10	N 89°53'00" E	22.85'
L11	S 45°07'00" E	9.90'
L12	S 00°15'02" W	164.23'
L13	N 00°00'00" E	4.82'
L14	N 89°35'39" E	24.98'
L15	S 89°58'58" E	297.00'
L16	N 89°53'05" E	461.32'
L17	N 89°52'52" E	25.16'
L18	S 89°58'17" E	132.50'
L19	N 00°06'55" W	24.79'
L20	S 55°14'06" E	68.80'
L21	N 00°19'15" W	471.87'
L22	N 89°51'28" E	546.60'
L23	N 42°20'06" W	25.22'
L24	S 89°51'15" W	20.16'
L25	S 89°54'35" W	359.35'
L26	N 00°02'04" W	294.31'
L27	N 88°48'55" E	38.70'
L28	S 50°48'40" W	15.40'
L29	N 59°11'30" E	17.82'
L30	S 70°07'58" W	15.33'
L31	S 84°34'49" W	10.61'
L32	S 79°39'05" W	12.88'
L33	N 87°12'48" W	9.96'

CURVE	RADIUS	ARC LENGTH	CHORD LENGTH	CHORD BEARING	DELTA ANGLE
C1	15.97'	21.58'	19.97'	S 44°16'46" E	77°23'57"
C2	41.00'	52.67'	49.12'	N 43°44'22" E	73°36'17"
C3	7.00'	11.00'	9.90'	S 44°53'00" W	80°00'00"
C4	4.00'	4.94'	4.63'	S 35°22'24" E	70°44'48"
C5	36.43'	37.98'	36.28'	N 58°38'35" E	59°44'11"
C6	7.00'	11.00'	9.90'	N 45°01'43" E	80°00'00"
C7	7.00'	9.83'	9.04'	N 49°47'59" E	80°27'29"
C8	7.00'	9.90'	9.09'	S 49°28'24" E	80°59'46"

L=92.87'
R=124.00'
Δ=42°54'42"
C LEN=90.71'
BRG=S 21°34'16" E

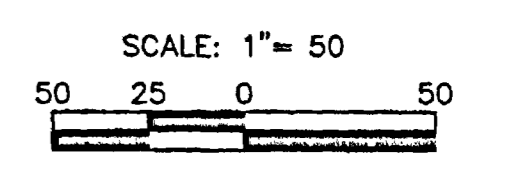

Prepared for: WTN CoEx I, LLC,
A Colorado limited liability company

NOTICE: ACCORDING TO COLORADO LAW YOU MUST COMMENCE ANY LEGAL ACTION BASED UPON ANY DEFECT IN THIS SURVEY WITHIN THREE YEARS AFTER YOU FIRST DISCOVER SUCH DEFECT. IN NO EVENT, MAY ANY ACTION BASED UPON ANY DEFECT IN THIS SURVEY BE COMMENCED MORE THAN TEN YEARS FROM THE DATE OF CERTIFICATION SHOWN HEREON.

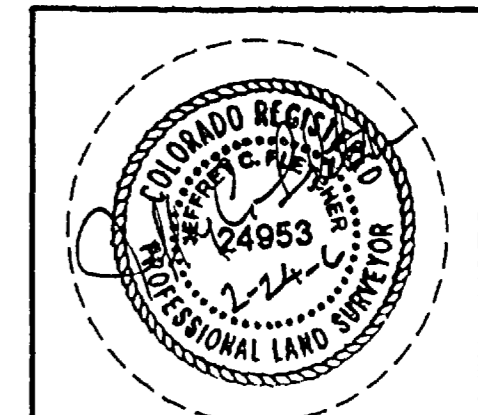

KOHL'S SUBDIVISION	
SW 1/4 SECTION 4 T1S, R1W, UTE MERIDIAN MESA COUNTY, COLORADO	
High Desert Surveying, LLC 2591 B 3/4 Road, Grand Jct., CO 81503 970-254-8649 Fax 970-255-7047	
SUR. BY: JT	DRAWN BY: JCF
JOB NO. 05-157	SHEET 3 OF 3
DATE: FEBRUARY 2, 2006	