

CONDOMINIUM MAP OF MONUMENT PARK CONDOMINIUM No. 3

TCP = 0
SIF = 0

CERTIFICATION

Monument Park Condominium Association Inc, a Colorado non-profit corporation is the owner of a tract of land situated within the City of Grand Junction, Mesa County, Colorado, being more particularly described as follows:

All of MONUMENT PARK CONDOMINIUM as recorded in Book 4079 at Pages 409 -411, Reception No. 2297497, of the Mesa County records, EXCEPT Condominium Units A1, A2, A3 and E1.

The owners certify that this Condominium Map of Monument Park Condominium No. 3 has been prepared pursuant to the purposes stated in the Declaration for Monument Park Condominium No. 3 as recorded in Book 4149, Pages 123-125 in the Clerk and Recorder's Office of Mesa County, Colorado.

Monument Park Condominium Association Inc.

By: Arthur Pastel

Title: Manager



STATE OF COLORADO)
COUNTY OF MESA) ss

The foregoing owner's certificate was acknowledged before me this 24th day of May A.D., 2006 by Arthur Pastel

Witness my hand and official seal John Lawrence
Notary Public
Address 786 Valley Ct GJ CO 81505
My commission expires 4-21-09

LIENHOLDERS RATIFICATION OF PLAT

The undersigned, hereby certifies that it is a holder of a security interest upon the property hereon described and does hereby join in and consent to the dedication of the land described in said dedication by the owners thereof and agrees that its security interest which is recorded in Book 3869 at Page 453 of the public records of Mesa County, Colorado, shall be subordinated to the dedications shown hereon.

WOODS 1992 TRUST

By: Nan Woods

Title: Trustee



STATE OF Colorado)
COUNTY OF Mesa) ss

The foregoing Lienholders Ratification was acknowledged before me this 24th day of May A.D., 2006 by Nan Woods.

Witness my hand and official seal John Lawrence
Notary Public
Address 786 Valley Ct GJ CO 81505
My commission expires 4-21-09

TITLE CERTIFICATION

State of Colorado
County of Mesa

We, Meridian Land Title, LLC a title insurance company, as duly licensed in the State of Colorado, hereby certify that we have examined the title to the hereon described property, that we find the title to the property is vested in Monument Park Condominium Association, Inc. a Colorado non-profit corporation; that the current taxes have been paid; that all mortgages not satisfied or released of record or otherwise terminated by law are shown hereon and that there are no other encumbrances of record; that all easements, reservations and right-of-ways of record are shown hereon.

Date: MAY 16, 2006

Meridian Land Title, LLC

By: L. D. VENT
Title: EXAMINER, MERIDIAN LAND TITLE, LLC

CITY APPROVAL

This condominium map of MONUMENT PARK CONDOMINIUM No. 3 a condominium in the City of Grand Junction, County of Mesa, State of Colorado, is approved and accepted on the 30 day of May, 2006.

John Lawrence
City Manager

John Lawrence
City Mayor

CLERK AND RECORDER'S CERTIFICATE

I hereby certify that this instrument was filed for recording in my office at 4:30 o'clock P.M., this 31 day of May A.D. 2006, and is duly recorded in Book No. 4149 at page 120-172 Reception No. 3320001 Fee \$ 31.00 Drawer No. KK-106

Deputy

Clerk and Recorder

CONDOMINIUM NOTES

Except for the Units, everything within the condominium boundary will be classified as General Common Element.

NOTICE: According to Colorado law you must commence any legal action based upon any defect in the survey within three years after you first discover such defect. In no event may any action based upon any defect in this survey be commenced more than ten years from the date of the certification / statement shown hereon.

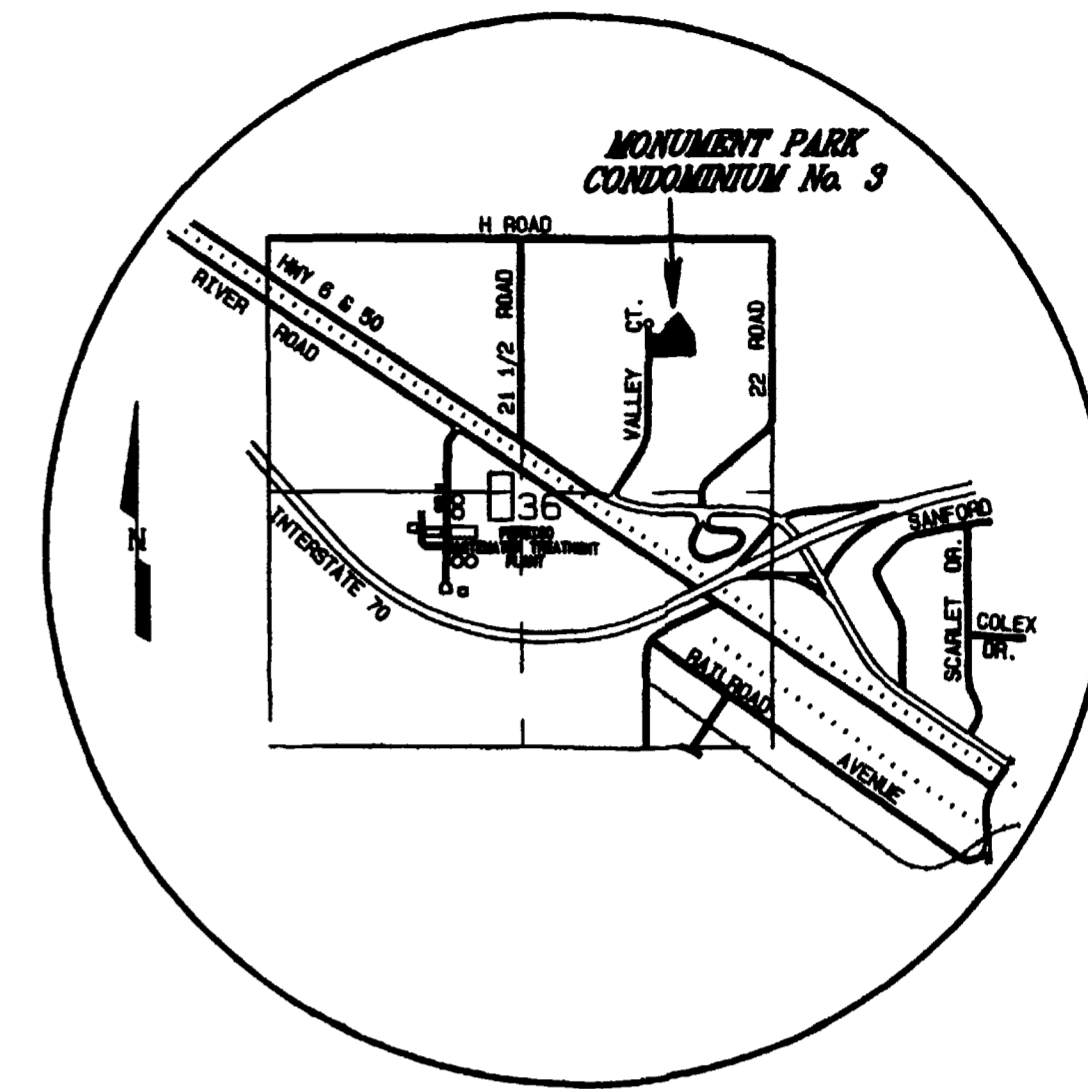

VICINITY MAP
NOT TO SCALE

SURVEYOR'S STATEMENT

I, Steven L. Hagedorn, a Professional Land Surveyor licensed in the State of Colorado, do hereby state that this map was prepared under my direct supervision, that it depicts the vertical and horizontal locations of each unit shown hereon, and that it was made from measurements upon and within the existing structures. This map contains all the information required by C.R.S. 38-33.3-209. The improvements and units shown hereon are substantially complete.



CONDOMINIUM MAP OF MONUMENT PARK CONDOMINIUM No. 3		
NE 1/4, SECTION 36, T.1N., R.2W., Ute Meridian		
D H SURVEYS INC.		
118 OURAY AVE. - GRAND JUNCTION, CO.		
(970) 245-8749		
Designed By <u>S.L.H.</u>	Checked By <u>M.W.D.</u>	Job No. <u>708-03-03</u>
Drawn By <u>THODEL</u>	Date <u>MAY, 2006</u>	Sheet <u>1 OF 3</u>

CONDOMINIUM MAP OF MONUMENT PARK CONDOMINIUM No. 3

TCP =

SIF =

VALLEY COURT

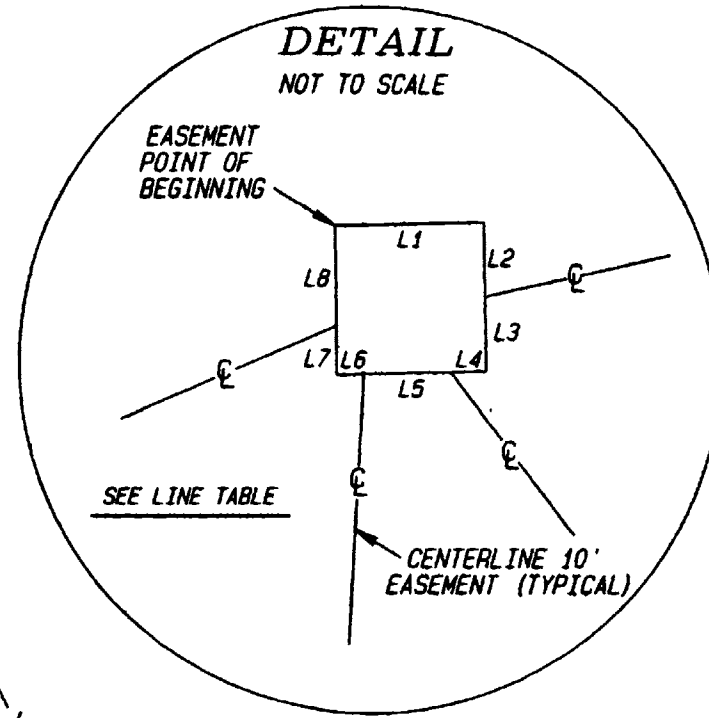
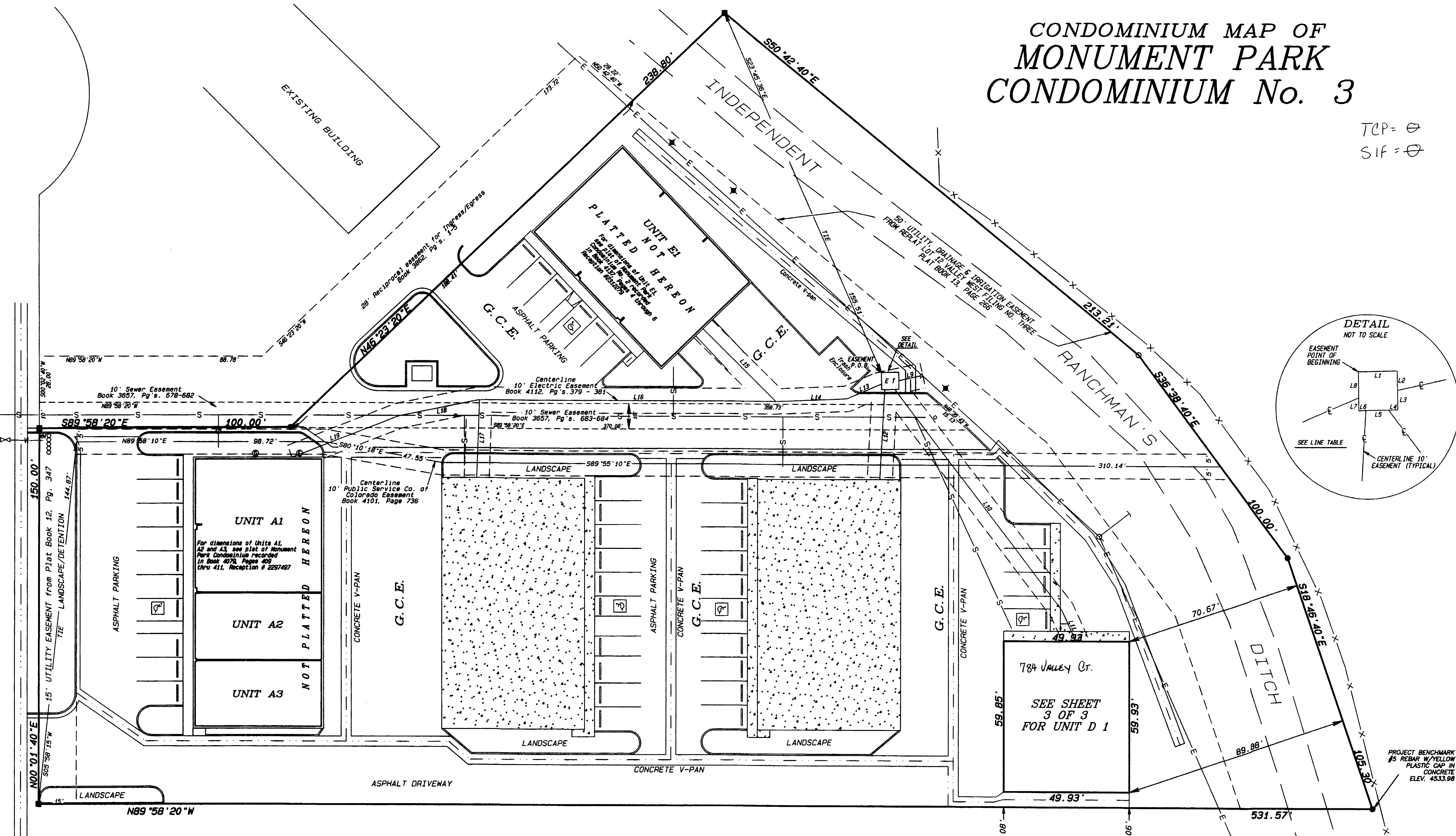

LEGEND & ABBREVIATIONS

- SET #5 REBAR WITH 2" ALUMINUM CAP STAMPED "D H SURVEYS INC LS 24306" AT FOUND BENT #5 REBAR
- FOUND ALUMINUM CAP IN CONCRETE STAMPED "WESTERN ENG. LS 28041"
- FOUND YELLOW PLASTIC CAP IN CONCRETE (ILLEGIBLE)
- FIRE HYDRANT
- WATER VALVE
- POWER POLE
- TELEPHONE PEDESTAL
- GAS METERS
- ELECTRIC METERS
- ELECTRIC TRANSFORMER BOX
- WATER METER
- CONCRETE
- G.C.E. = GENERAL COMMON ELEMENT
- P.O.B. = POINT OF BEGINNING
- S— SANITARY SEWER LINE
- W— WATER LINE
- E— OVERHEAD ELECTRIC LINE
- ...— FLOW LINE

ELECTRIC EASEMENT LINE TABLE

LINE	BEARING	DISTANCE
L1	N89°34'04"W	6.88'
L2	S00°58'07"E	3.42'
L3	S00°58'07"E	3.38'
L4	S89°28'25"W	1.64'
L5	S89°28'25"W	4.82'
L6	S89°28'25"W	1.24'
L7	N00°44'54"W	2.24'
L8	N00°44'54"W	4.57'
L9	N77°23'50"E	9.13'
L10	S37°15'10"E	109.84'
L11	S24°23'40"E	13.39'
L12	S03°05'37"W	36.60'
L13	S66°51'42"W	15.04'
L14	S07°46'58"W	26.25'
L15	N45°37'37"W	40.23'
L16	N89°52'54"W	118.19'
L17	S02°00'28"W	31.05'
L18	S78°33'35"W	32.94'
L19	S68°37'28"W	45.49'

SURVEYOR'S NOTE

Offset dimensions shown are from property lines to outside face of foundation wall.

NOTICE: According to Colorado law you must commence any legal action based upon any defect in the survey within three years after you first discover such defect. In no event may any action based upon any defect in this survey be commenced more than ten years from the date of the certification / statement shown hereon.

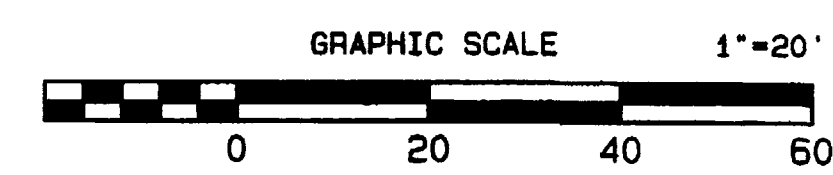

CONDOMINIUM MAP OF
MONUMENT PARK CONDOMINIUM No. 3
NE 1/4, SECTION 36, T.1N., R.2W., Ute Meridian

D H SURVEYS INC.
118 OURAY AVE. - GRAND JUNCTION, CO.
(970) 245-8749

Designed By S.L.H.	Checked By M.W.D.	Job No. 708-03-03
Drawn By T.M.O.E.L.	Date APRIL, 2006	Sheet 2 OF 3

CONDOMINIUM MAP OF MONUMENT PARK CONDOMINIUM No. 3

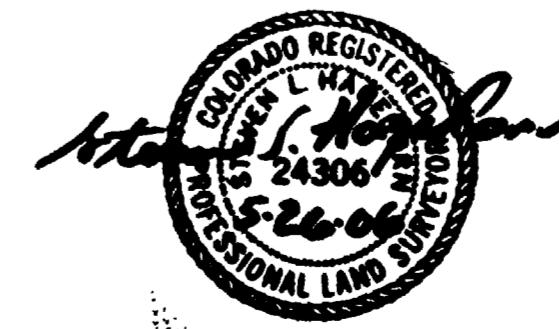
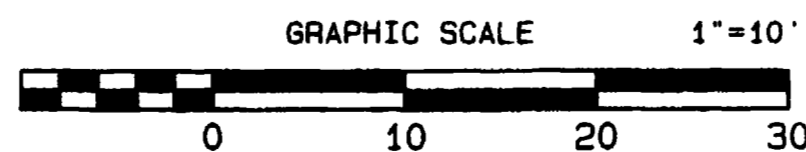
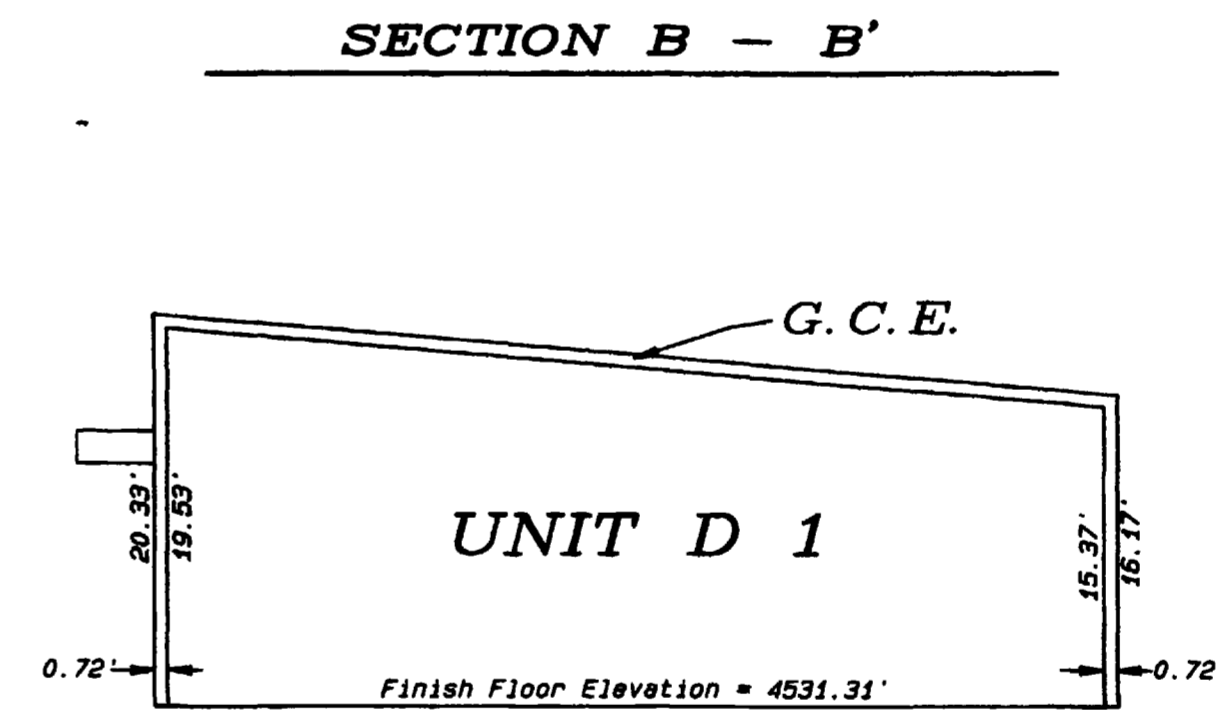
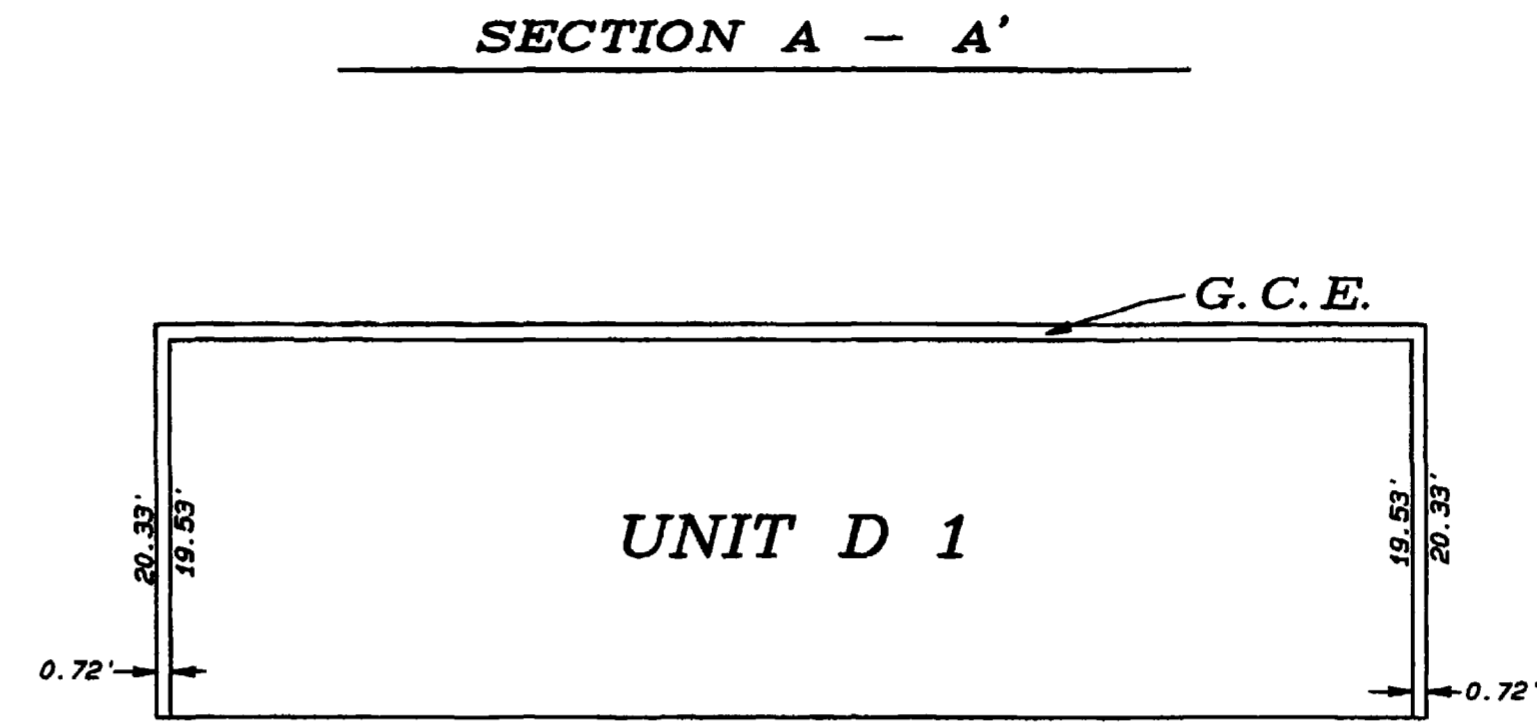
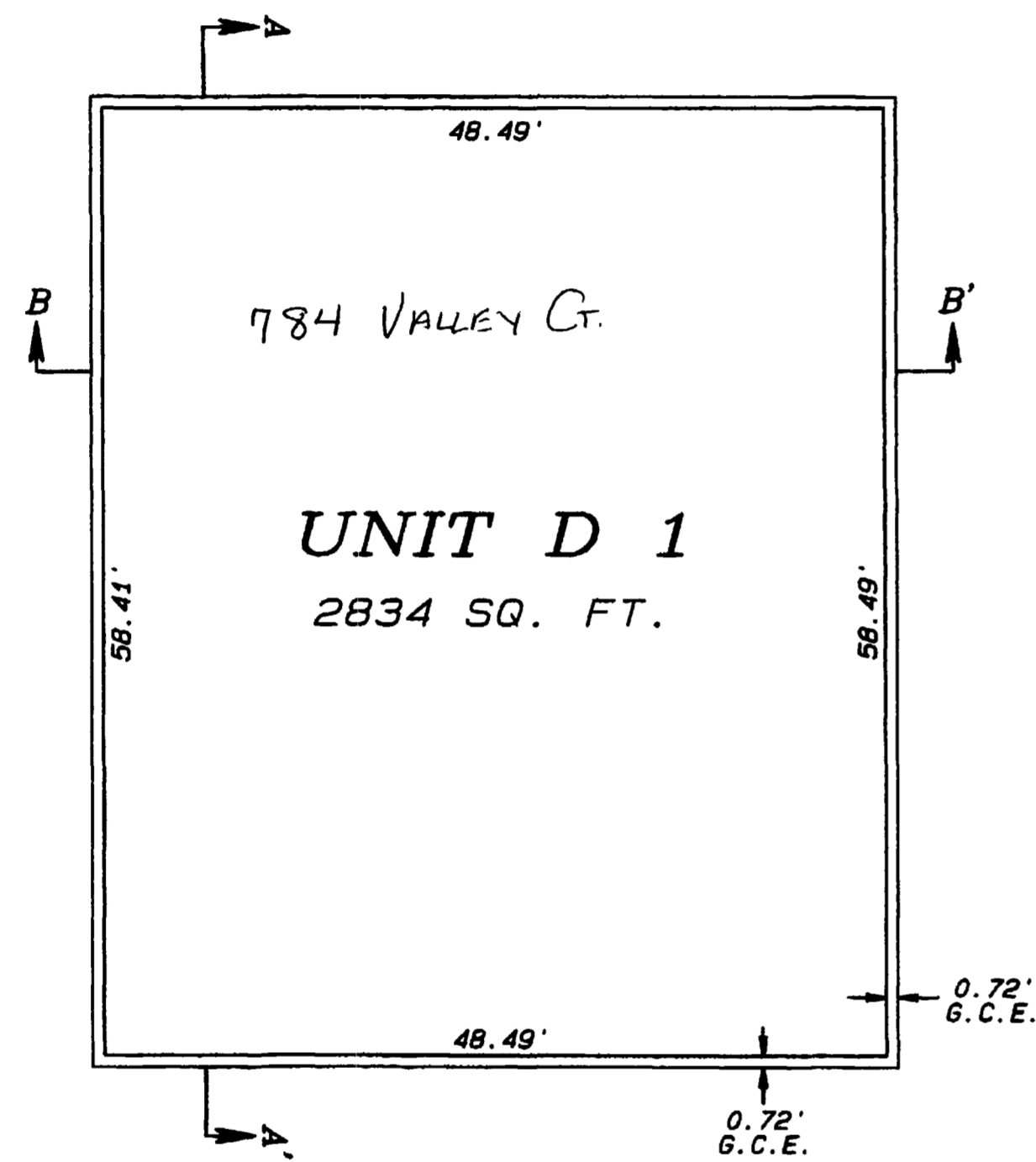

CONDOMINIUM MAP OF
MONUMENT PARK CONDOMINIUM No. 3
NE 1/4, SECTION 36, T.1N., R.2W., Ute Meridian
D H SURVEYS INC.
118 OURAY AVE. - GRAND JUNCTION, CO.
(970) 245-8749

Designed By S.L.H.	Checked By M.W.D.	Job No. 708-03-03
Drawn By TMODEL	Date APRIL, 2006	Sheet 3 OF 3

NOTICE: According to Colorado law you must commence any legal action based upon any defect in the survey within three years after you first discover such defect. In no event may any action based upon any defect in this survey be commenced more than ten years from the date of this certification/statement shown hereon.