

# CONDOMINIUM MAP OF MONUMENT PARK CONDOMINIUM No. 4

### CERTIFICATION

Monument Park Condominium Association Inc, a Colorado non-profit corporation is the owner of a tract of land situated within the City of Grand Junction, Mesa County, Colorado, being more particularly described as follows:

All of MONUMENT PARK CONDOMINIUM as recorded in Book 4079 at Pages 409 - 411, Reception No. 2297497, of the Mesa County records, EXCEPT Condominium Units A1, A2, A3 as recorded in Book 4079 at Pages 409-411, Reception No. 2297497, Unit E1, as recorded in Book 4137 at Pages 4-6, Reception No. 2312279 and Unit D1 as recorded in Book 4169 at Pages 120-122, Reception No. 2320001.

The owners certify that this Condominium Map of Monument Park Condominium No. 4 has been prepared pursuant to the purposes stated in the Declaration for Monument Park Condominium No. 4 as recorded in Book 4209 Pages 476-478 in the Clerk and Recorder's Office of Mesa County, Colorado.

Monument Park Condominium Association Inc.  
By: Arthur M. Pastei  
Title: Manager

STATE OF COLORADO )  
COUNTY OF MESA ) ss

The foregoing owner's certificate was acknowledged before me this 16<sup>th</sup> day of July A.D., 2006 by Arthur M. Pastei  
Witness my hand and official seal [Signature]  
Address 786 Valley Court Grand Junction CO 81505  
My commission expires 4-21-09

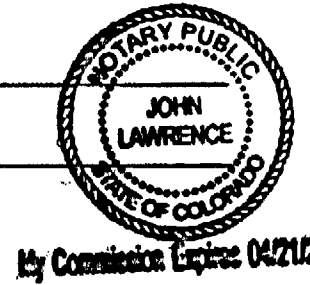

### LIENHOLDERS RATIFICATION OF PLAT

The undersigned, hereby certifies that it is a holder of a security interest upon the property hereon described and does hereby join in and consent to the dedication of the land described in said dedication by the owners thereof and agrees that its security interest which is recorded in Book 3869 at Page 463 of the public records of Mesa County, Colorado, shall be subordinated to the dedications shown hereon.

WOODS 1992 TRUST  
By: Nan Woods  
Title: Trustee

STATE OF Colorado )  
COUNTY OF Mesa ) ss

The foregoing Lienholders Ratification was acknowledged before me this 16<sup>th</sup> day of July A.D., 2006 by Nan Woods  
Witness my hand and official seal [Signature]  
Address 786 Valley Ct Grand Junction CO 81505  
My commission expires 4-21-09

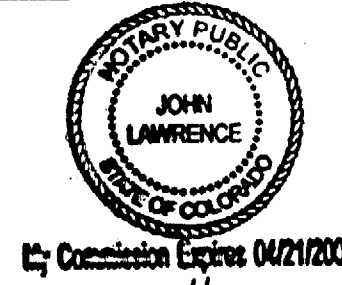

### TITLE CERTIFICATION

State of Colorado  
County of Mesa

We, Meridian Land Title, LLC a title insurance company, as duly licensed in the State of Colorado, hereby certify that we have examined the title to the hereon described property, that we find the title to the property is vested in Monument Park Condominium Association, Inc. a Colorado non-profit corporation; that the current taxes have been paid; that all mortgages not satisfied or released of record or otherwise terminated by law are shown hereon and that there are no other encumbrances of record; that all easements, reservations and right-of-ways of record are shown hereon.

Date: July 13, 2006

Meridian Land Title, LLC  
By: [Signature]  
Title: EXAMINER  
MERIDIAN LAND TITLE, LLC

### CITY APPROVAL

This condominium map of MONUMENT PARK CONDOMINIUM No. 4 a condominium in the City of Grand Junction, County of Mesa, State of Colorado, is approved and accepted on the 20 day of JULY, 2006.

[Signature]  
City Manager

[Signature]  
City Mayor

### CLERK AND RECORDER'S CERTIFICATE

I hereby certify that this instrument was filed for recording in my office at 3:52 o'clock P.M., this 24<sup>th</sup> day of July A.D. 2006, and is duly recorded in Book No. 4209 at page 473-475 Reception No. 2329139. Fee \$ 30.00 + 1.00 Drawer No. KK-110

\_\_\_\_\_  
Deputy

\_\_\_\_\_  
Clerk and Recorder

### CONDOMINIUM NOTES

Except for the Units, everything within the condominium boundary will be classified as General Common Element.

NOTICE: According to Colorado law you must commence any legal action based upon any defect in the survey within three years after you first discover such defect. In no event may any action based upon any defect in this survey be commenced more than ten years from the date of the certification / statement shown hereon.

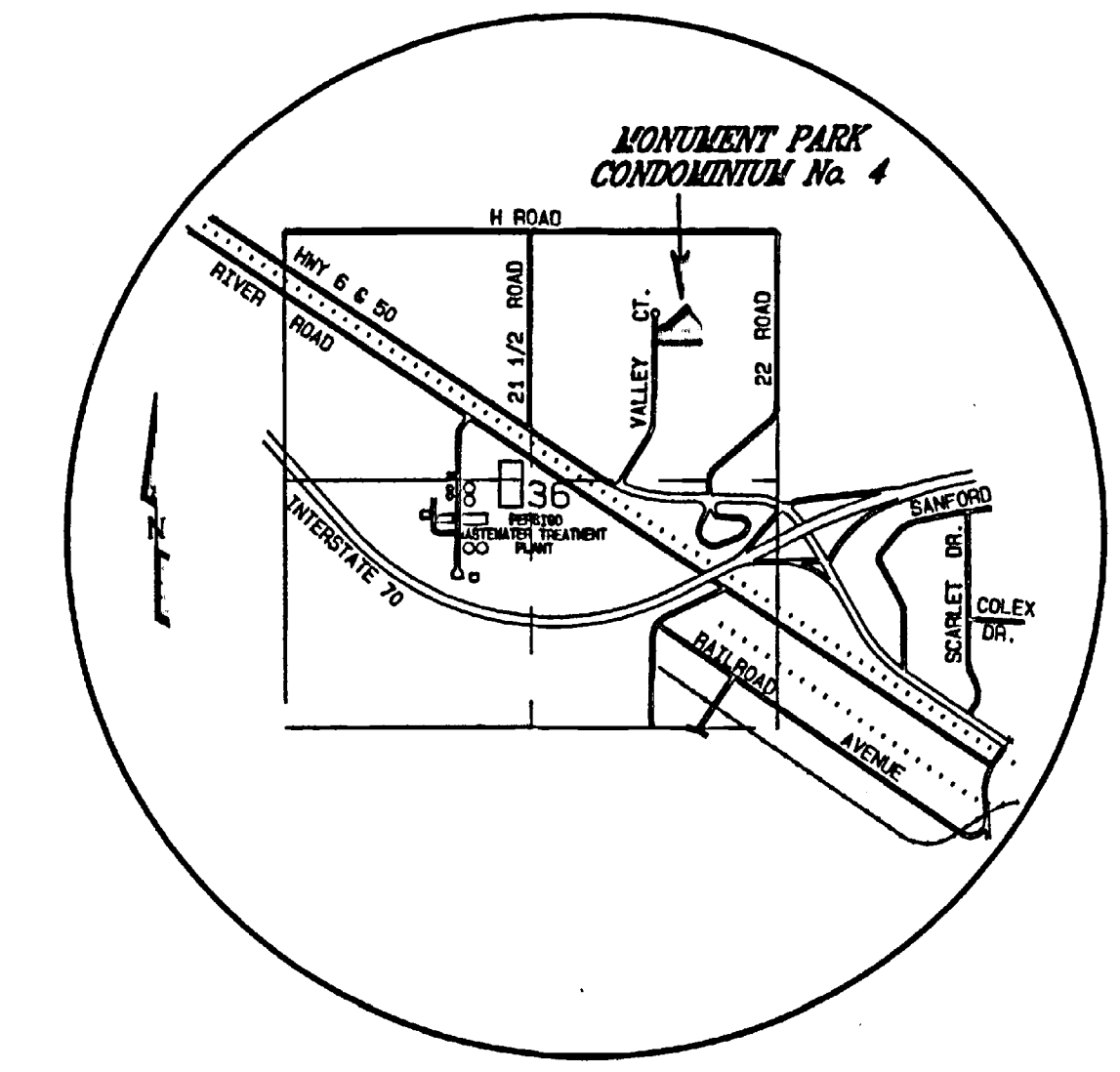

VICINITY MAP  
NOT TO SCALE

### SURVEYOR'S STATEMENT

I, Steven L. Hagedorn, a Professional Land Surveyor licensed in the State of Colorado, do hereby state that this map was prepared under my direct supervision, that it depicts the vertical and horizontal locations of each unit shown hereon, and that it was made from measurements upon and within the existing structures. This map contains all the information required by C.R.S. 38-33.3-209. The improvements and units shown hereon are substantially complete.

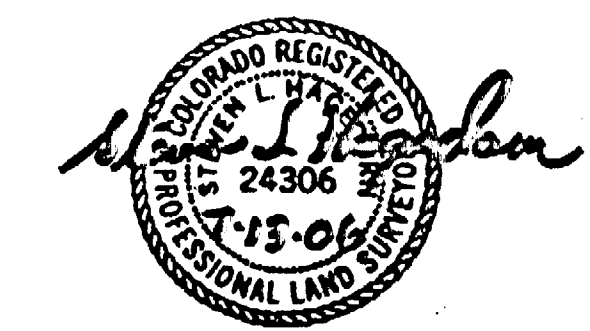

**CONDOMINIUM MAP OF  
MONUMENT PARK CONDOMINIUM No. 4**  
NE 1/4, SECTION 36, T.1N., R.2W., Ute Meridian  
**D H SURVEYS INC.**  
118 OURAY AVE. - GRAND JUNCTION, CO.  
(970) 245-8749

Designed By S.L.H.	Checked By M.W.D.	Job No. 708-03-03
Drawn By TMODEL	Date JULY, 2006	Sheet 1 OF 3



# CONDOMINIUM MAP OF MONUMENT PARK CONDOMINIUM No. 4

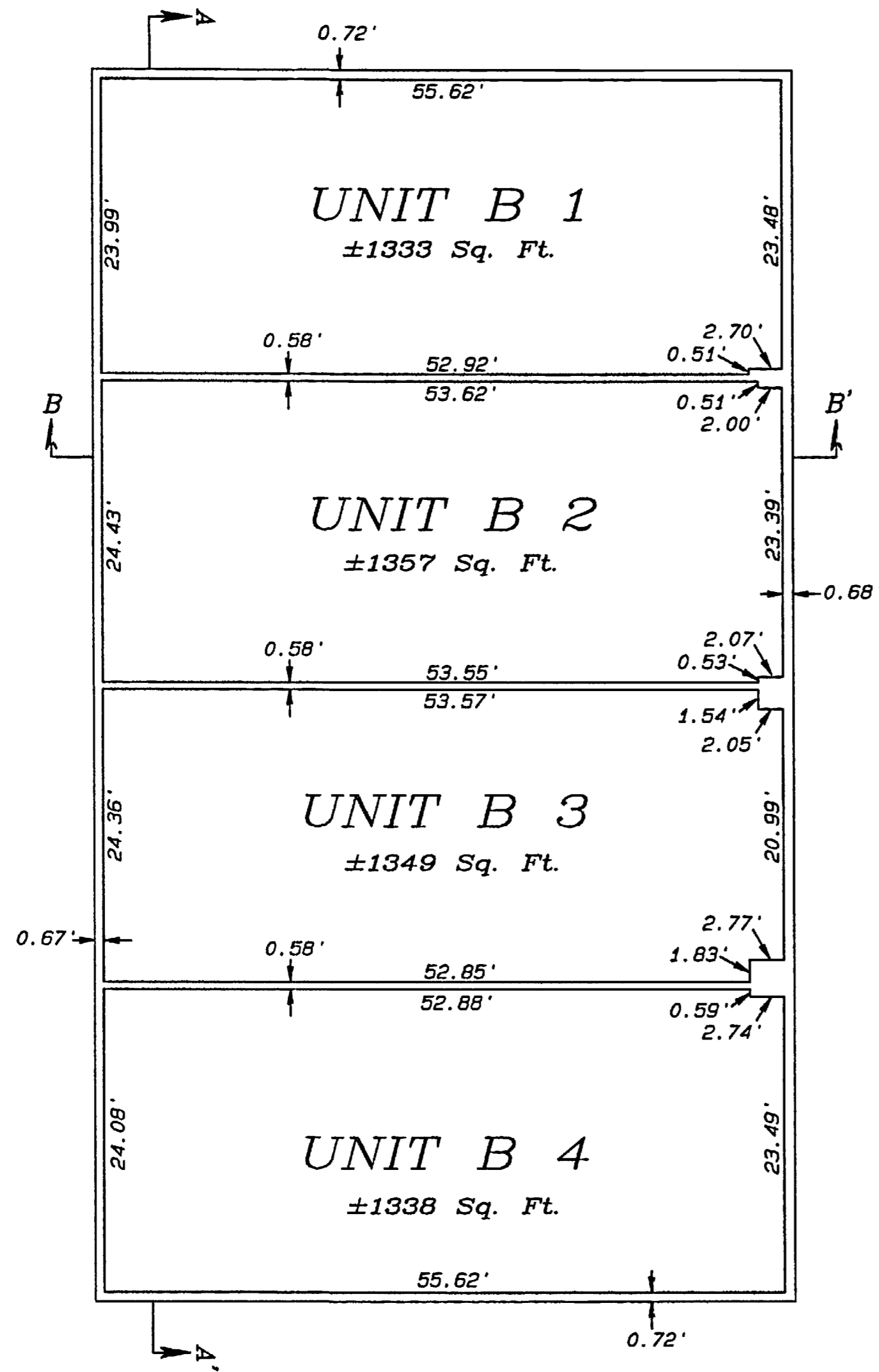

SECTION A - A'

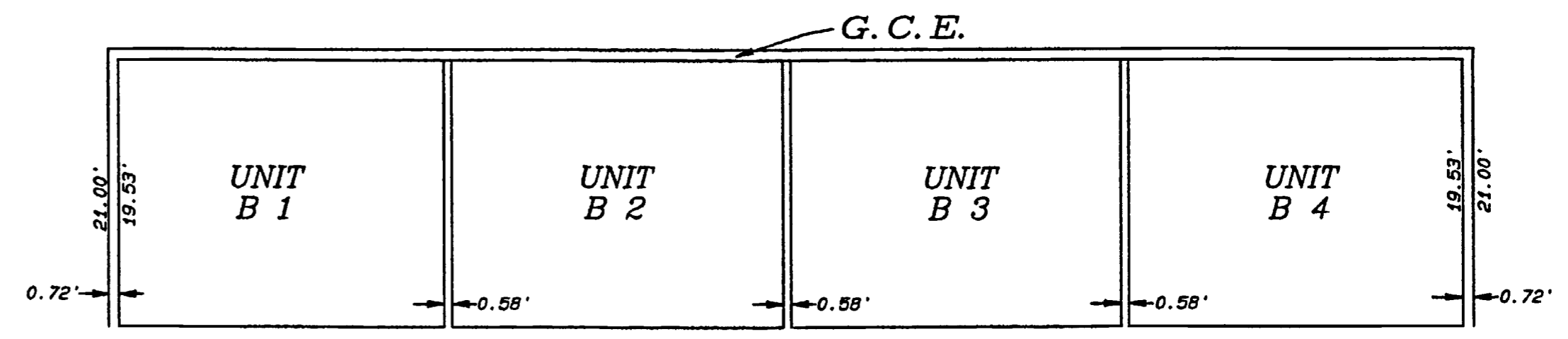

SECTION B - B'

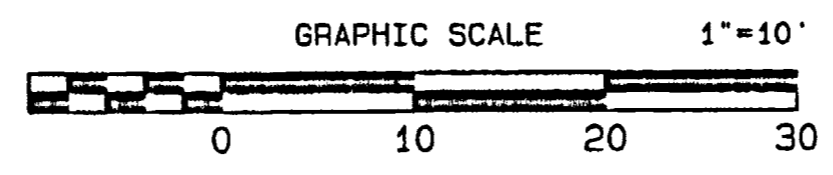
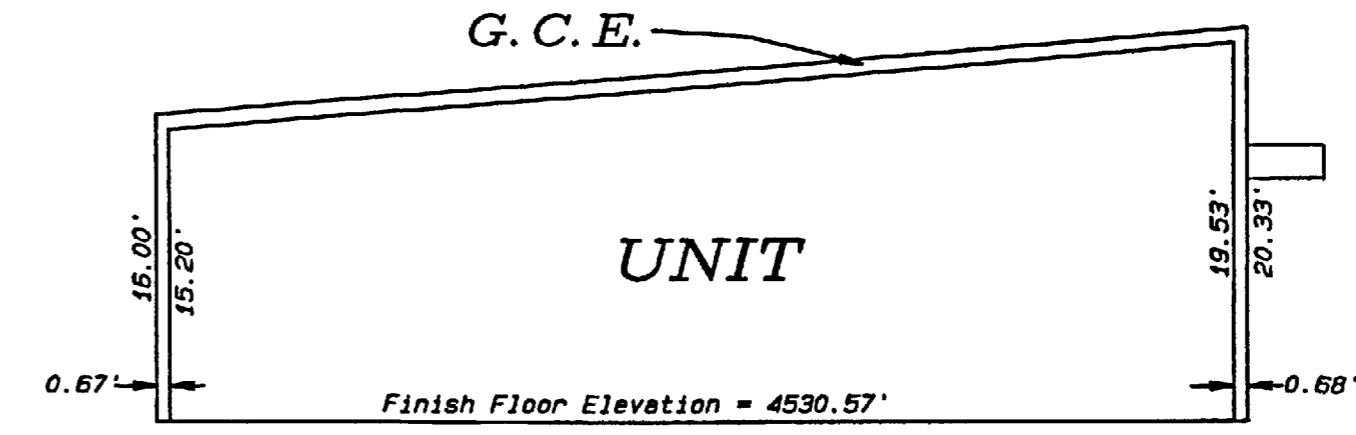

CONDOMINIUM MAP OF  
**MONUMENT PARK CONDOMINIUM No. 4**  
NE 1/4, SECTION 36, T.1N., R.2W., Ute Meridian  
**D H SURVEYS INC.**  
118 OURAY AVE. - GRAND JUNCTION, CO.  
(970) 245-8749

Designed By S.L.H.	Checked By M.W.D.	Job No. 708-03-03
Drawn By TMODEL	Date JULY, 2006	Sheet 3 OF 3

NOTICE: According to Colorado law you must commence any legal action based upon any defect in the survey within three years after you first discover such defect. In no event may any action based upon any defect in this survey be commenced more than ten years from the date of this certification/statement shown hereon.