

KNOW ALL MEN BY THESE PRESENTS THAT A C NELMS AND OMA NELMS BEING THE OWNERS OF THE FOLLOWING DESCRIBED LAND TOWIT: LOT 7 BLOCK 2 FAIRMOUNT SUBDIVISION, AS RECORDED IN BOOK 1 ON PAGE 19 IN THE OFFICE OF THE CLERK AND RECORDER OF THE COUNTY OF MESA STATE OF COLORADO

HAVE LAID OUT AND PLATTED A C NELMS SUBDIVISION OF SAID LAND, DO HEREBY DEDICATE THE STREETS AVENUES AND ALLEYS AS SHOWN HEREON TO THE USE OF THE PUBLIC FOREVER.

A C Nelms  
Oma Nelms

STATE OF COLORADO } S S  
 COUNTY OF MESA }

THE FOREGOING INSTRUMENT WAS ACKNOWLEDGED BEFORE ME THIS 13 DAY OF June 1947 BY A C NELMS AND OMA NELMS MY COMMISSION EXPIRES JUNE 19-1948

Richard B. Williams  
 NOTARY PUBLIC

I CERTIFY THAT THIS IS A TRUE AND CORRECT PLAT OF THE ABOVE DESCRIBED LAND AND THE SUBDIVISION THEREOF

Roy L. George  
 SURVEYOR

THIS PLAT OF A C NELMS SUBDIVISION IS ACCEPTED FOR FILING SUBJECT TO THE OBLIGATION TO MAINTAIN ONLY EXISTING COUNTY HIGHWAYS SHOWN HEREON.

MESA COUNTY BOARD OF COUNTY COMMISSIONERS  
 DATED: 6-18-1947

ATTEST: A. P. Morse E. S. Wayne  
 DEPUTY COUNTY CLERK Walter Stout for  
Secretary

THE  
 A C NELMS SUBDIVISION  
 OF  
 LOT 7 BLOCK 2  
 FAIRMOUNT SUBDIVISION  
 MESA COUNTY COLORADO

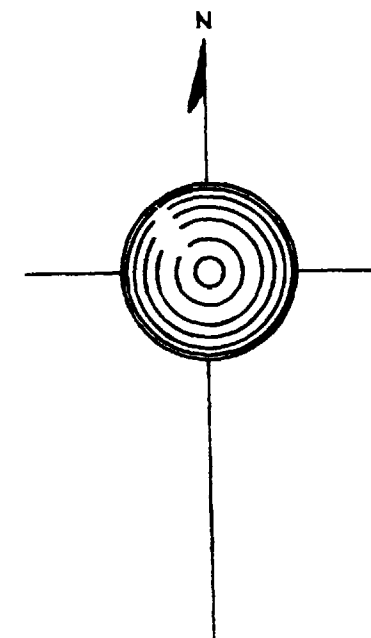

SCALE 1" = 50'

