

# Table of Contents

File 1985-0017

Project Name Mt. Bell Heliport - 2524 N. Foresight Ave. -

P r e s e n t	S c a n n e d	<p>A few items are denoted with an asterisk (*), which means they are to be scanned for permanent record on the in some instances, not all entries designated to be scanned by the department are present in the file. There are also documents specific to certain files, not found on the standard list. For this reason, a checklist has been provided.</p> <p>Remaining items, (not selected for scanning), will be marked present on the checklist. This index can serve as a quick guide for the contents of each file.</p> <p>Files denoted with (**) are to be located using the ISYS Query System. Planning Clearance will need to be typed in full, as well as other entries such as Ordinances, Resolutions, Board of Appeals, and etc.</p>		
X	X	<b>Table of Contents</b>		
X	X	<b>Review Sheet Summary</b>		
X		Application form		
		Review Sheets		
		Receipts for fees paid for anything		
		<b>*Submittal checklist</b>		
X	X	<b>*General project report</b>		
		Reduced copy of final plans or drawings		
		Reduction of assessor's map		
		Evidence of title, deeds, easements		
X	X	<b>*Mailing list to adjacent property owners</b>		
		Public notice cards		
		Record of certified mail		
		Legal description		
		Appraisal of raw land		
		Reduction of any maps - final copy		
		<b>*Final reports for drainage and soils (geotechnical reports)</b>		
		Other bound or nonbound reports		
		Traffic studies		
		Individual review comments from agencies		
X	X	<b>*Petitioner's response to comments</b>		
		<b>*Staff Reports</b>		
		<b>*Planning Commission staff report and exhibits</b>		
		<b>*City Council staff report and exhibits</b>		
		<b>*Summary sheet of final conditions</b>		
		<b>*Letters and correspondence dated after the date of final approval (pertaining to change in conditions or expiration date)</b>		
<b>DOCUMENTS SPECIFIC TO THIS DEVELOPMENT FILE:</b>				
X	X	Action Sheet	X	Landscape Plan
X	X	Review Sheet Summary	X	Floor Plan
X	X	Planning Commission Minutes - ** - 5/28/85, 6/25/85, 10/7/86	X	Section & Framing Map
X		Planning Clearance - ** - 9/3/85	X	Mechanical Plan
X		Development Application - no date		
X		Notice of Public Hearing - 10/7/86		
X		Public Notice Posting - 9/25/86		
X	X	Petition		
X	X	Sound Study Results		
X	X	Noise Assessment Guidelines		
		Letter from Dennis Roberts, Regional Aviation Planner to Mike Southerland, Planning Dept. re: sample noise assessment - 6/9/86		
X	X	Petition		
X	X	Letter against - from Del and Edna Wanger - 5/28/85 and Herb High & Trudy High - 10/09/86		
X	X	Letter from Mike Fergione to Planning re: follow-up to workshop - 6/21/85		
X	X	Letter from Mike Fergione to Bob Goldin re: new approach and departure procedures for helicopter procedures - 4/23/85		
X		Site Plan		

May 17, 1985  
Grand Junction, CO

RECEIVED GRAND JUNCTION  
PLANNING DEPARTMENT

MAY 17 1985

Mr. Karl G. Metzner  
Planning Director  
City of Grand Junction  
Grand Junction, CO

Dear Karl:

Mountain Bell has just purchased a Bell 20623 helicopter which will be used primarily for remote microwave maintenance. We have numerous microwave sites located throughout Western Colorado. All of these sites will be maintained by my microwave crew which is presently located at 2524 North Foresight Avenue. The helicopter will normally be used on a daily basis and operate between the hours of 0700 and 1800. We presently are operating with one helicopter but anticipate using a second ship in the very near future. Our policy is to fly within the above specified hours, however, serious outages could modify this plan. Any night flying would be very minimal and practically non-existent. We have two requests to submit for your consideration.

- #1. We request permission to begin using 2524 North Foresight Avenue as a helipad as soon as possible. The helicopter would normally come to this location from the airport and pick up our technicians every morning. They would usually leave immediately for the distant sites. It would then return the technicians in the afternoon and depart for the airport.
- #2. We request permission to begin operation as a heliport on approximately July 1, 1985. We would use our existing building as a hangar and maintenance area for the helicopter. We would fuel the helicopter from our service truck which would obtain fuel from an underground tank at the same location. This operation would be co-located with our present automotive operations department. They are presently housing, maintaining, and providing fuel for numerous cars, trucks, and units of heavy equipment.

*Do we have  
fuel tank?*

Thank you for your consideration on our request. We are trying this new concept in an effort to provide quicker response to trouble conditions with the net result of better service to all of our customers on the entire Western Slope. If there are any additional questions I can be reached on 244-4050.

Sincerely,

*Ron Carey*

Ron Carey  
Manager - Network Switched Services

RNC:slt





Grand Junction Planning Department  
559 White Ave. Room 60  
Grand Junction, Colorado 81501-2643

May 22, 1985

Mr. Ron Carey  
Manager - North Area  
Mountain Bell  
800 Main Street  
Grand Junction, CO 81501

Dear Ron:

In response to your request for a heliport at 2524 North Foresight Avenue, the Grand Junction Planning Commission will be reviewing this on May 28th at 7:30 p.m. in the City/County Auditorium. You should be in attendance and be able to respond to their concerns as outlined:

- 1) Show the proposed flight corridors you will be utilizing.
- 2) Show the location of the heliport in relation to your building, Foresight Park and the proposed 230KV power line.
- 3) Problems, if any, anticipated as the area to the north develops in approved high density residential zoning projects.
- 4) Consideration of allowing other companies within Foresight Park to utilize your helipad facility (through landing easements, etc.) This will allow consolidation rather than each company, i.e. Public Service Company, United Cable, KJCT, and new businesses, requesting helipad operations.
- 5) How many helicopters will be utilized within this facility?

Upon response to these concerns, the Grand Junction Planning Commission will make a motion regarding your heliport facility.

If you have questions, please contact me at 244-1628. Thank you for your continued cooperation.

Sincerely,

Bob Goldin  
Senior City Planner

BG/tt

Delbert F. & Edna E. Wanzer  
2520 F $\frac{1}{2}$  Road  
Grand Junction, CO 81505

Ron Carey  
Mt. Bell  
2524 Blichmann Ave.  
Grand Junction, CO 81505

Colorado West Improvements, Inc  
P.O. Box 1330  
Grand Junction, CO 81502

1480 Welton Inc.  
P.O. Box 840  
Denver, CO 80201

Robert G. Wilson  
167 Little Park Road  
Grand Junction, CO 81503

Herbert C. & Trudy L. High  
2524 F $\frac{1}{2}$  Road  
Grand Junction, CO 81505

Howard C. & Paula Hildebrant  
3222 Mesa Ave.  
Clifton, CO 81520

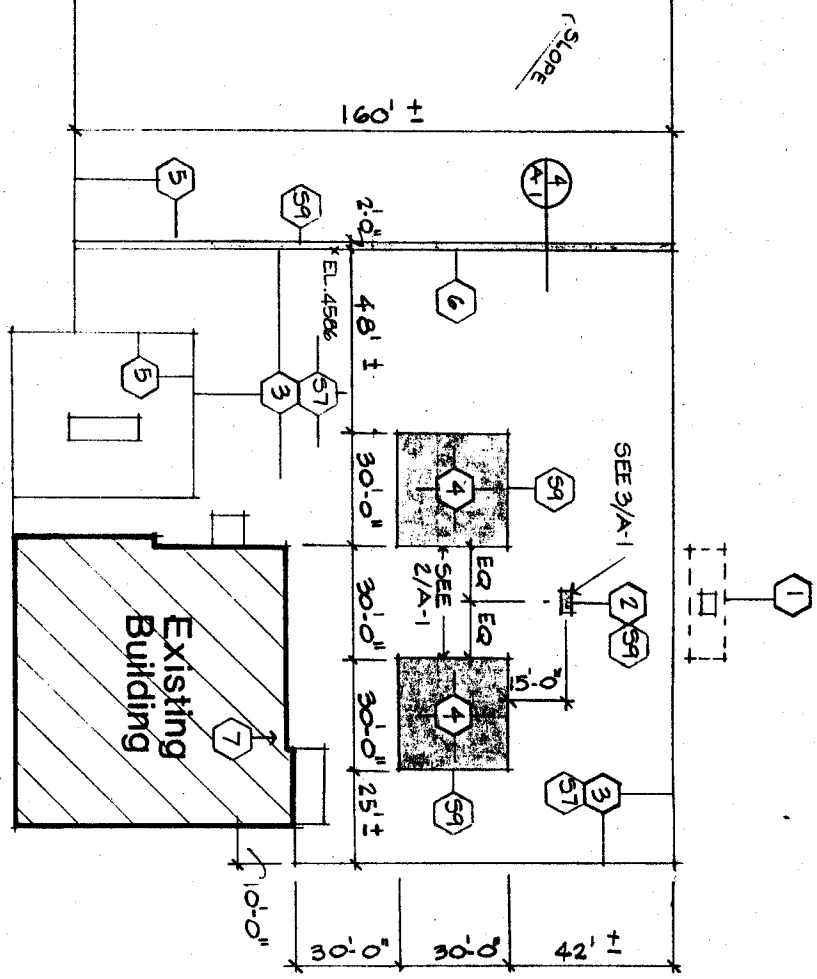

F 1/2 ROAD

## SOUND STUDY RESULTS

A noise study was done at the proposed heliport location on Friday, May 31. The results and a report of that study, I understand, will be submitted by the City Health Department. For reference in this report, they have been included below.

The purpose of the study was to determine what type of approach, and from what direction, would be the quietest in relation to all the other possibilities.

The measurements were taken from a distance of approximately 75' from the landing area, from a point inside the "baffled fence area" of the heliport. No measurements were taken from across the street, or outside of the fence.

This approach revealed a sound propagation caused by an echo bouncing off the building adjacent to the heliport. It also gave us a better reading of engine noise. The fence helped to contain the noise levels.

The quietest spot within the heliport boundary was located, and found to be very close to our original choice for the landing pad. Both engine noise and rotor blade noise were least from that point.

You will notice that the results show an approach from the north from 300' registered as the quietest. We believe this is because the aircraft was at its lowest and most shielded point from the instrument, whereas, during the approaches from the north, there was a direct "line of sight path" between the instrument and the aircraft.

The noise levels of the aircraft during short final and at a hover, were nearly the same in all cases, except for the position of the aircraft on or in the actual heliport area. There is about a 15 second transition area where the aircraft is coming out of a "forward flight mode" into a "hovering mode" that is shown in the study as Landing and Short Final. Blade slap is likely to occur in that area, and generally cannot be avoided except for limiting the duration of the noise.

The general agreement was that the best approach in terms of noise and safety was from the Southwest over the Industrial Area from an altitude above the ground of not less than 500 feet, and a rate of descent of greater than 800 feet per minute to avoid the blade slap regime.

The "Noisy Approach" was done from overhead the instrument, paying no attention to noise abatement procedures, and the aircraft was kept as close to the instrument as possible throughout the approach, using a spiraling down technique with the helicopter. Blade slap was encouraged at all times, rate of descent was 400 - 500 feet per minute.

SOUND STUDY MEASUREMENTS

Conditions

Cloudy

68°F

Pressure 29.88

Time:

0340-0915

1. Approach From North at 500' AGL

Approach 80 db  
Hover 95 db  
Departure 77 db

Loudest Reading 98 db

Aircraft Position - Short Final

2. Approach From North at 300' AGL

Approach 75 db  
Hover 83 db  
Departure 75 db

Loudest Reading 87 db

Aircraft Position - Short Final

\* \* 3. Approach From Southwest at 500' AGL

Approach 75 db  
Hover 80 - 84 db  
Departure 82 db

← Best Approach

Loudest Reading 88 db

Aircraft Position - Short Final

Reading before approach was started - 60 to 65 db

4. Approach From Southwest at 300' AGL

Approach 82 db  
Departure 85 db  
Hover 88 db

Loudest Reading 92 db

Aircraft Position - Short Final

5. Noisy Approach

Approach 80 db  
Hover 83 db  
Aircraft Overhead 70 - 75 db

6. Miscellaneous Readings

Landing 80 db  
Flight Idle 76 db  
(Engine & Rotor Noise)

Truck moving across parking lot  
65 db



# HELIPORT SKETCH

NOT TO SCALE

F 1/2 Rd

BARBED FENCE

② LOCATION OF MEASURING DEVICE

PROPOSED HANGAR

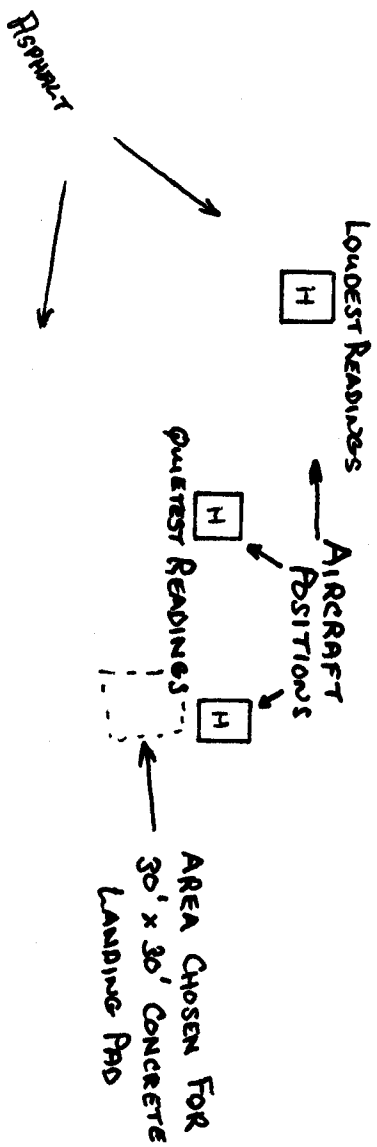

CAR & TRUCK OVERHEAD SHELTERS

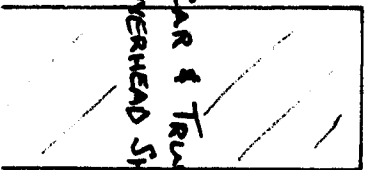
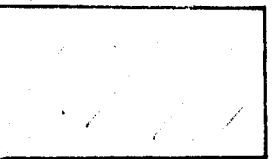

HIGH RESIDENTIAL ZONING

CANAL

MINIMUM ALLOWABLE ALTITUDE OUTSIDE OF SHADED AREA 500'  
MINIMUM RATE OF DESCENT 800 FPM

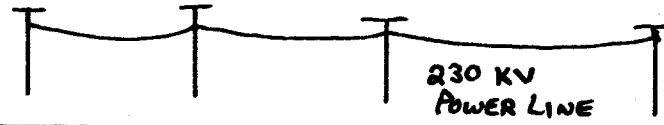

230 KV POWER LINE

F 1/2 RD

HELIPORT

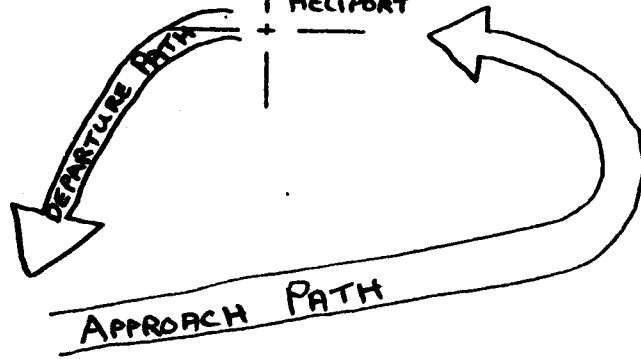

341' RADIO TOWER

RESIDENTIAL AREAS

440' RADIO TOWER

F RD

INDUSTRIAL AREA

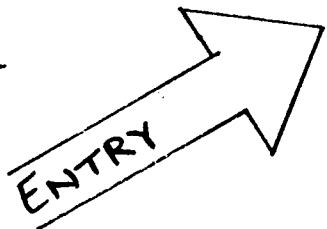

MOBILE HOME PARK

AS RD

FORESIGHT PARK  
APPROACH AND DEPARTURE PROCEDURES

COLD RIVER

U.S. DEPARTMENT OF TRANSPORTATION FEDERAL AVIATION ADMINISTRATION <b>NOTICE OF LANDING AREA PROPOSAL</b>		<input checked="" type="checkbox"/> ESTABLISHMENT OR ACTIVATION <input type="checkbox"/> ALTERATION <input type="checkbox"/> DEACTIVATION OR ABANDONMENT <input type="checkbox"/> CHANGE OF STATUS		<input type="checkbox"/> AIRPORT OF <input checked="" type="checkbox"/> HELIPORT <input type="checkbox"/> SEAPLANE BASE		
NAME OF PROPONENT, INDIVIDUAL OR ORGANIZATION <b>MOUNTAIN BELL TELEPHONE</b>			ADDRESS (No., Street, City, State, Zip Code) <b>2524 N. FORESIGHT GRAND JUNCTION, CO 81505</b>			
<b>A. LOCATION OF LANDING AREA</b>						
1. NEAREST CITY OR TOWN <b>GRAND JUNCTION</b>		2. COUNTY <b>MESA</b>		3. STATE <b>COLORADO</b>		
5. NAME OF LANDING AREA <b>MOUNTAIN BELL HELIPORT</b>		6. LATITUDE <b>39° 05' 51"</b>		7. LONGITUDE <b>108° 35' 00"</b>		
		8. ELEVATION <b>4580</b>		4. DISTANCE & DIRECTION FROM NEAREST CITY OR TOWN <b>2 SE</b>		
<b>B. PURPOSE</b>						
TYPE USE <input type="checkbox"/> PUBLIC <input checked="" type="checkbox"/> PRIVATE <input type="checkbox"/> PERSONAL		TYPE OWNERSHIP <input type="checkbox"/> PUBLIC <input checked="" type="checkbox"/> PRIVATE		LOCALITIES SERVED <b>COLORADO &amp; EASTERN UTAH</b>		
IF CHANGE OF STATUS OR ALTERATION, DESCRIBE CHANGE.				CONSTRUCTION DATES TO BEGIN 'BEGAN <b>IMMEDIATE</b> EST. COMPLETION <b>JULY 5, 1985</b>		
<b>C. OTHER LANDING AREAS</b>			<b>D. LANDING AREA DATA</b>			
REF. AS ABOVE DRCT. FROM LANDING AREA DIST. FROM LANDING AREA			1. <b>AIRPORT OR SEAPLANE BASE</b> EXISTING (If any)   PROPOSED MAGNETIC BEARING OF RUNWAY(S) OR SEALANE(S) LENGTH OF RUNWAY(S) OR SEALANE(S) IN FEET WIDTH OF RUNWAY(S) OR SEALANE(S) IN FEET MAGNETIC BEARING OF PRIMARY LANDING DIRECTION TYPE OF RUNWAY SURFACE (Concrete, Asphalt, Grass, Etc.)			
<b>WALKER FIELD AIRPORT</b> <b>060° 3 3/4 mi</b>			2. <b>HELIPORT</b> DIMENSIONS OF LANDING AND TAKEOFF AREA IN FEET DIMENSIONS OF TOUCHDOWN AREA IN FEET MAGNETIC DIRECTION OF INGRESS EGRESS ROUTES TYPE OF SURFACE (Turf, rooftop, etc.)			
<b>E. OBSTRUCTIONS</b>			3. DESCRIPTION OF LIGHTING (If any) ALL <b>QUARTZ LIGHTS ON CONCRETE PAD</b> DIRECTION OF PREVAILING WIND <b>W</b>			
TYPE		HEIGHT ABOVE LANDING AREA	DRCT. FROM LANDING AREA	DIST. FROM LANDING AREA	F. OPERATIONAL DATA (If est. indicate by letter "E") PRESENT   ANTICIPATED 5 YRS.-HENCE	
RADIO TOWER		440'	245°	4000'	1. EST. OR ACTUAL NO. BASED ACFT.	
RADIO TOWER		241'	100°	3000'	AIRPORTS MULTIENGINE SINGLE-ENGINE	
					HELIPORTS UNDER 3500 LBS. MGW OVER 3500 LBS. MGW	
<b>G. NOISE CONSIDERATIONS</b>			2. AVERAGE NO. MONTHLY LANDINGS AIR CARRIER GENERAL AVIATION OTHER (Military, glider, etc.)			
IDENTIFICATION		DRCT. FROM LANDING AREA	DIST. FROM LANDING AREA	3. ARE IFR OPERATIONS ANTICIPATED <input checked="" type="checkbox"/> NO <input type="checkbox"/> YES WITHIN _____ YEARS TYPE NAVAID:		
HORIZON VIEW BAPTIST CHURCH and SCHOOL		145°	3/4 mi	H. APPLICATION FOR AIRPORT LICENSING <input type="checkbox"/> HAS BEEN MADE <input checked="" type="checkbox"/> NOT REQUIRED <input type="checkbox"/> COUNTY <input type="checkbox"/> WILL BE MADE <input type="checkbox"/> STATE <input type="checkbox"/> MUNICIPAL AUTHORITY		
POMONA ELEMENTARY SCHOOL		140°	3/4 mi			
KOLONGIA CHURCH		340°	1 mi			
RESIDENTIAL MOBILE HOME PARK		130°	3/4 mi			
<b>I. CERTIFICATION:</b> I hereby certify that all of the above statements made by me are true and complete to the best of my knowledge.						
NAME AND TITLE OF PERSON FILING THIS NOTICE (Type or print) <b>MICHAEL C. FERGIONE</b> <b>BASE CHIEF PILOT</b>			SIGNATURE (In ink) <i>Michael C. Fergione</i> DATE OF SIGNATURE <b>5/14/85</b> TELEPHONE NO. (Precede with area code) <b>(303) 244-4018</b>			

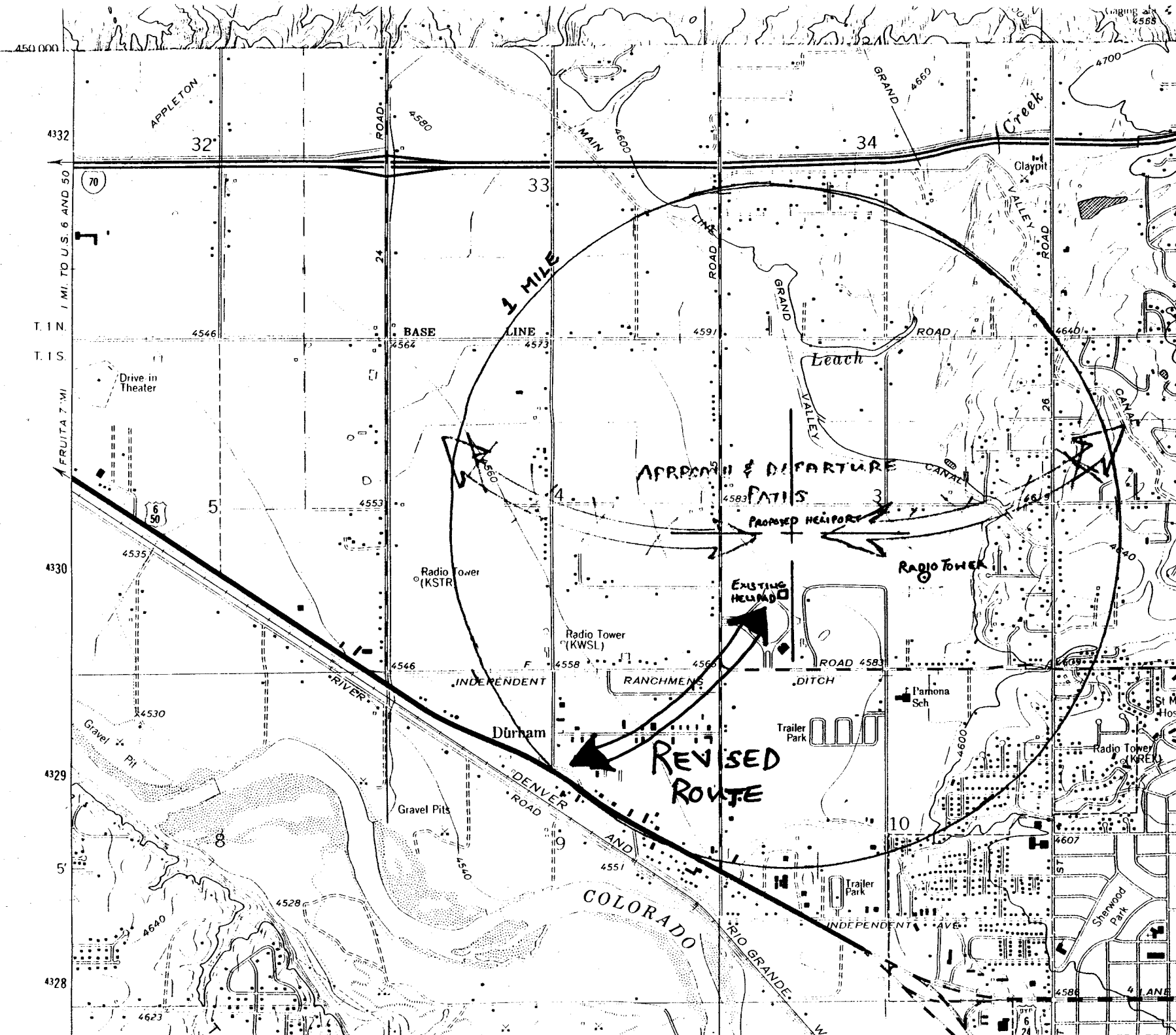

4332  
32°  
T. 1 N.  
T. 1 S.  
FRUITA 7 MI.  
4330  
4329  
5  
4328

APPLETON

ROAD

1 MILE

BASE LINE

GRAND

Creek

Leach

APPROXIMATE DEPARTURE

POINTS

PROPOSED HELIPORT

RADIO TOWER

Radio Tower (KSTR)

EXISTING HELIPORT

Radio Tower (KWSL)

INDEPENDENT

RANCHMENS

DITCH

Parona Sch

Durham

Trailer Park

REVISED ROUTE

Radio Tower (KREK)

DENVER

COLORADO

RIO GRANDE

INDEPENDENT AVE

Sherwood Park

4 LANE

DTP 6 24



U.S. Department  
of Transportation  
Federal Aviation  
Administration

# Advisory Circular

---

**Subject:**

**Date:** 12/9/83

**AC No:** 150/5020-2

**Initiated by:** AEE-110

**Change:**

NOISE ASSESSMENT GUIDELINES FOR  
NEW HELIPORTS

---

## FOREWORD

This circular provides technical guidance for local planners, other government agencies, and operators in calculating the acoustic environment near new heliports. It is intended to provide assistance in preliminary evaluation of the noise compatibility of sites for heliports where none exists. It is not intended for the evaluation of existing heliports or those areas where noise is not an issue.

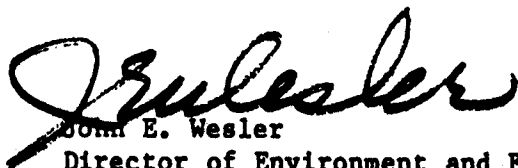

John E. Wesler  
Director of Environment and Energy

---

## TABLE OF CONTENTS

	Page
SECTION 1. INTRODUCTION.....	5
1. Purpose.....	5
2. Background.....	5
3. Overview.....	5
SECTION 2. PLANNING FACTORS.....	6
4. General.....	6
5. Ambient Noise.....	6
6. Sound of Helicopters.....	6
7. Route Planning Considerations.....	6
8. Acoustical Considerations in Site Selection.....	7
SECTION 3. CRITERIA SELECTION.....	7
9. General.....	7
10. Sound Level Units.....	7
11. Normally Compatible Sound Levels.....	8
12. Number of Helicopter Events.....	8
13. Technical Assistnce.....	9
SECTION 4. NOISE CALCULATION PROCEDURES.....	12
14. General.....	12
15. Site/Operational Information.....	12
16. Simplified Method.....	12
17. Detailed Procedure.....	15
18. Comparison of Simplified and Detailed Methods.....	16
19. Elevated Heliports.....	16
20. Sound Measurements.....	16
SECTION 5. REMEDIAL ACTIONS.....	17
21. Alternatives.....	17
APPENDIX 1. Example of Detailed Helicopter Leq Calculation.....	18
FIGURE 1 Recommended Maximum Number of Events.....	10
TABLE 1 Normally Compatible Community Sound Levels.....	11
TABLE 2 Recommended Maximum Number of Events.....	14

SECTION 1. INTRODUCTION

1. PURPOSE. This circular provides technical guidance for local planners, other government agencies, and operators in calculating the acoustic environment near new heliports. It is intended to provide assistance in preliminary evaluation of the noise compatibility of sites for heliports where none exists. It is not intended for the evaluation of existing heliports or those areas where noise is not an issue (e.g., offshore oil rigs). Further, more detailed environmental analysis may be required under Orders 1050.1D and 5050.4 where there is an FAA action in approving the establishment of the heliport.

2. BACKGROUND. FAA Orders 1050.1D and 5050.4 provide detailed procedures for the environmental assessment of all FAA actions under the National Environmental Policy Act (P.L. 91-190, 42 USC 4321) and a number of other statutes, regulations and orders. However, the private sector and local authorities need standardized methods for preliminary evaluation of potential sites for new heliports. This advisory circular is intended to fill the need and to give "quick-look" capability without the detailed (often computer-based) computations necessary to a full NEPA assessment.

3. OVERVIEW. A two-phase process is suggested to ensure that heliport planning includes effective means for evaluating and minimizing noise impacts.

- The first phase uses estimated noise levels and distances to determine relatively simply whether a proposed facility would meet recommended noise criteria. This analysis can be made using the simplified method (paragraph 16) and the data of Table 1 without the need for detailed measurements.

- The second phase can be used if, based on the earlier estimate, the proposed facility would not clearly meet the recommended noise criteria. Detailed noise readings should then be taken to determine whether the heliport would meet the criteria. This analysis can be accomplished using Table I and either the detailed (paragraph 17) or simplified method, as appropriate.

The applicant should be allowed to participate in the analysis and to modify his proposal as appropriate to meet the criteria. Alternatives for modifying a heliport plan are listed in paragraph 21. After thorough study of these alternatives by all parties involved, reanalyses can be performed based on either estimates or measured data.

## SECTION 2. PLANNING FACTORS

4. GENERAL. The helicopter is typically operated at low altitudes and, as a result, it frequently comes within the audible range of people. Further, helicopters are becoming more widely used in both urban and suburban areas. Therefore, the sound is generated in close proximity to where people live and work. This closeness accentuates the concern associated with the external sound of the helicopter and its acceptability to the communities in which it operates. It is an underlying philosophy of the procedures and recommendations of this guide that each heliport siting is a unique situation. Thus the application of any procedure may not necessarily result in a satisfactory solution for every community and operator. In these regards, individual consideration should be given to such factors as ambient noise, the specific nature of the noise sensitive areas which may be impacted by heliport operations, and seasonal variations in operation.

5. AMBIENT NOISE. People's concerns about aircraft noise are often reflections of the degree to which the aircraft intrudes on existing ambient noise exposure patterns. Ambient noise at a specific location is a composite of sounds from many sources including automobile, truck and bus traffic, motorcycles, construction noise, aircraft, etc. The ambient noise level in an area continually varies with time as the result of varying levels of activity. This activity, and hence the resultant ambient noise, changes with time of day, day of the week and the seasons.

6. SOUND OF HELICOPTERS. The noise footprint of a helicopter during approach, landing, takeoff, and departure is considerably smaller than that of many airplanes. The sound of a helicopter is comparable in level to other sounds that are acceptable to the community. That acceptance is often due to familiarity. Heavy trucks and city buses are examples of sounds which are equivalent in sound level to helicopters. The sound generated by a helicopter, however, is different in character from other forms of transportation. Each mode of flight, takeoff, landing and flyover, can produce different combinations of sound. Often the sound is new to an area. For these reasons, the helicopter is readily identified and may be singled out for complaint.

7. ROUTE PLANNING CONSIDERATIONS. The flight path to and from a proposed heliport should take advantage of low noise sensitivity corridors, i.e., over freeways, and railways, bodies of water, etc. Routes should be selected to avoid noise sensitive facilities such as schools, churches, rest homes, large open-air gatherings of people, etc. Rapid turns as well as other transient maneuvers can give rise to changes in the character and level of the sound. These maneuvers should be avoided whenever practical, particularly near residential areas. The flyover altitude should also be chosen, within reason, to be the highest practicable since doubling the flyover height will decrease the peak sound level heard on the ground by more than 6 decibels. Thus, routes at 1000 to 2000 ft. altitude are preferable to 500 ft. (Advisory Circular 91-36B recommends 2000 ft. minimum altitude over populated areas.) In the past, there has been a tendency for helicopters to operate at low



altitudes even when there has been no necessity due to safety or Air Traffic Control requirements. The FAA is currently working with a number of cities to designate VFR corridors specifically for helicopters, in order to reduce public impacts. The FAA also supports the helicopter industry's "Fly Neighborly" program to reduce noise effects.

8. ACOUSTICAL CONSIDERATIONS IN SITE SELECTION. The FAA's Heliport Design Guide (AC 150/5390-1B) should be consulted in selecting and developing a heliport site. Where noise impacts are a consideration, it may also be desirable to consider sites in or near high activity areas such as near thoroughfares, freeways, busy streets, railways, etc., since the noise generated by such facilities will tend to mask the sounds generated by the helicopter. Of course, heliports are also compatible in open areas. Except for emergency use, heliports should not be located adjacent to such facilities as schools, churches, and rest homes. Elevated heliports should be considered separately from ground level sites. (See paragraph 19.) Clear zones and helistops on rooftops should be encouraged in recognition of the helicopter's demonstrated rescue and evacuation potential in emergency situations, such as fires.

### SECTION 3. CRITERIA SELECTION

9. GENERAL. Outside noise levels have generally proven to be reliable indicators of community response to sound exposure, and most standards use them exclusively. For this reason, the environmental criteria for heliports are based on external sound only. However, in some cases, particularly for sites near schools and hospitals, it may be more appropriate to consider indoor sound levels. In these cases it is not possible to generalize, and each case must be treated on an individual basis.

#### 10. SOUND LEVEL UNITS.

a. Single Event Measure. The Aviation Safety and Noise Abatement Act of 1979 (P.L. 96-193, 49 USC 2101) required that the FAA establish a single system for measuring and evaluating noise impacts. That system, as incorporated in FAR Part 150 and Order 1050.1D, is the family of units based on the "A" weighted sound level. For heliports, the FAA chose the Sound Exposure Level (SEL), which is a single-event measure combining both the events maximum intensity and its duration. A mathematical explanation of this unit is given in FAR Part 150, Appendix A. Values of SEL for various helicopters may be obtained from:

- (1) Measurements using an integrating sound level meter, or
- (2) Listings of sound exposure levels provided by the FAA or helicopter manufacturers.

In either case, the individual values of SEL for each helicopter takeoff, landing and flyover are combined by the methods contained in this Advisory Circular and compared against the community noise levels.

b. Community Noise Level. So that the relative contributions of the heliport and other sound sources in the community can be compared the FAA recommends the use of a cumulative noise measure, the 24 hour equivalent sound level (EQL). This unit is similar to the day-night average sound level (DNL) specified in FAR Part 150 for evaluating the community noise levels around airports for fixed-wing aircraft. The only difference between EQL and DNL is that DNL adds a 10 dB penalty to night flights between 10:00 p.m. and 7:00 a.m. Helicopter EQL values are obtained by adding logarithmically the single-event SEL values over a 24 hour period.

#### 11. NORMALLY COMPATIBLE SOUND LEVELS.

a. Criteria. Public Law 96-193 (cited above) also directs the FAA to identify land uses which are "normally compatible" with various levels of noise from aircraft operations. Because of the size and complexity of many major hub airports and their operations, FAR Part 150 identifies a large number of land uses and their associated noise levels. However, since the operations of most heliports tend to be much simpler and the impacts more restricted in area, Part 150 does not apply to heliports off the airport property. Instead, for individual heliports the FAA recommends the simpler criteria contained in Table 1. These recommended levels were chosen on the basis of the criteria typically found to be acceptable in areas by type. The community is divided into three basic area categories: "residential", "commercial", and "industrial", with energy equivalent (EQL) noise levels as shown in Table 1.

b. Compatibility. The maximum recommended cumulative sound level (EQL) due to the proposed operations of helicopters at a new site should not exceed the ambient noise level already present in the community at the site of the proposed heliport. This means, the average equivalent helicopter noise level should not exceed the values recommended in Table 1, or the locally measured ambient noise level.

c. Ambients. In cases where it is felt that ambient noise levels significantly differ from those given in the table it is recommended that measurements be made. If the observed ambient for the area around the site exceeds that listed in Table 1, the maximum recommended EQL noise levels should be increased accordingly. See paragraph 20 for suggestions on measurement techniques.

d. Applications. As outlined in paragraphs 7 and 8, the heliport site and related ingress/egress routes should be selected for minimal community noise impact. Examples of this type of route include highways, rail lines, bodies of water, etc. However, it is inevitable that there will be some areas or facilities near the heliport that may be affected by the helicopter operations. These may include single family residences, apartment complexes, condominiums, schools, churches, and rest homes. One or more of these areas or facilities can be identified from maps and plots for use in determining the noise compatibility of the proposed heliport site. Facilities associated with the operation of the proposed heliport itself should not be considered noise sensitive.

12. NUMBER OF HELICOPTER EVENTS. Using the normally compatible sound level criteria defined above, it is possible to compute the maximum permitted number of helicopter events (takeoffs, landings, and flyovers). The resultant number of events will depend on the magnitude of the sound exposure levels from the individual events, as well as the ambient noise level in the general area. The procedures for determining this number are described in Section 4 below.

13. TECHNICAL ASSISTANCE. Assistance in the use of these procedures may be obtained from the Office of Environment and Energy, AEE-110, telephone (202) 755-9027. Noise data from fifteen helicopter types are provided in "Helicopter Noise Exposure Curves for Use in Environmental Impact Assessment," Report FAA-EE-82-16, AEE-120. Data on additional types of helicopters in a format compatible with the noise calculation procedure (Section 4) may be available from AEE-120, telephone (202) 426-3396, or from the manufacturer. In choosing the data to be employed in any of these analyses, caution should be taken to assure that they are representative of the weights, conditions and operational procedures that may actually be flown at the proposed heliport. Assistance in this area is obtainable from the FAA Region or from the Helicopter Association International (HAI), which has extensive resources and file information on successful heliport operations. This information may be obtained by contacting HAI at 1110 Vermont Avenue, N.W., Washington, D.C. 20005, Attention: Heliport Director. The HAI telephone is (202) 466-2420.

DIFFERENCE BETWEEN  
HELICOPTER SOUND  
EXPOSURE LEVEL AND  
COMMUNITY SOUND  
LEVEL FROM TABLE 1

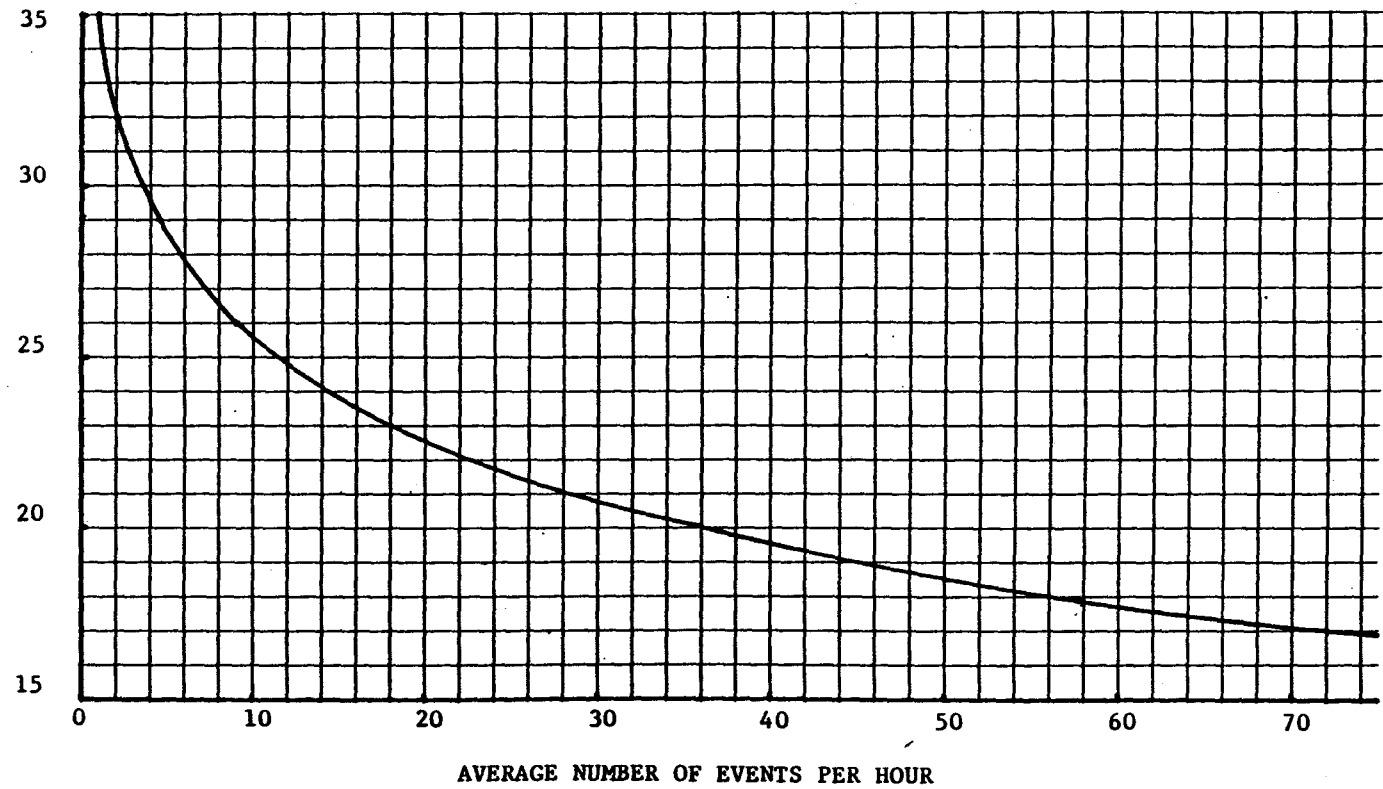

Figure 1. Recommended Maximum Number of Events

TABLE 1

## Normally Compatible Community Sound Levels

TYPE OF AREA	24-HOUR AVERAGE EQUIVALENT NOISE LEVEL (EQL)  (A-weighted decibels)
RESIDENTIAL	
SUBURBAN	57
URBAN	67
CITY CENTER	72
COMMERCIAL	72
INDUSTRIAL	77

#### SECTION 4. NOISE CALCULATION PROCEDURES

14. GENERAL. The maximum recommended 24-hour average equivalent helicopter noise level is one that equals, but does not exceed, the 24-hour average equivalent ambient sound levels for the community into which the proposed heliport would be introduced. Two procedures are provided for such assessments. The first of these involves a simple analysis which, in most cases, will provide sufficient information, particularly for heliports with relatively few operations. The second, more detailed procedure is intended for those heliports where the first analysis indicates marginal acceptability.

15. SITE/OPERATIONAL INFORMATION. There may be many routes into a heliport site and all of the potential alternatives should be known in advance of the application, and reported. Flight profiles, each of which may be composed of several FAA approved alternatives, should also be described. The heliport evaluation should consider the mix of routes and flight profiles which constitute the normal planned operations. If it is known in advance that noise abatement profiles may be needed for particular routes, they should be included in the application. All proposed routes should be detailed on a land use map of the heliport area. Generally, the following information is required:

- . Location of possible noise sensitive facilities or areas near the heliport site.
- . Routes and flight trajectories to and from the heliport.
- . Helicopter sound level versus distance data from Report FAA-EE-82-16 or the manufacturer.

Designation of noise sensitive areas and facilities is made by municipal officials from a land use survey of the area surrounding the heliport site. If there are several noise sensitive facilities or areas near the same route, each should be evaluated. Facilities directly associated with the heliport are excluded.

#### 16. SIMPLIFIED METHOD.

a. As mentioned in paragraphs 9 and 10, both the helicopter and community ambient sound levels are evaluated using an energy equivalent (averaging) noise metric, EQL. This unit includes the effects of both level and duration of each noise event and the number of events. The simplified method allows a tradeoff between the Sound Exposure Level and the number of events.

b. Single Helicopter Type and/or Route. Using criteria described above, a recommended maximum number of helicopter events per hour has been developed. It is shown in Figure 1 and listed in Table 2. In determining the hourly average, the daily total number of events is divided by 24. The procedure is as follows:

(1) Determine the closest point of approach of the helicopter for the nearest flight path (takeoff or approach) to the designated noise sensitive area or facility.

(2) Determine the single-event helicopter sound exposure level (SEL) by referring to Report FAA-EE-82-16 or to manufacturers' data (furnished by the applicant) for the slant range of the closest point of approach and the appropriate flight condition. If a relationship between noise and slant range is not included in the furnished data, it may be assumed that sound exposure level decreases as ten times the logarithm of the distance ratio ( $10 \log_{10} R/R_0$ ) which is three dB per doubling of distance.

(3) Subtract the average community equivalent sound level (EQL) value (Table 1) from the sound exposure level (SEL) determined above. Use this value to enter either Figure 1 or Table 2 to find the recommended maximum number of helicopter events. If the proposed number of events is less than or equal to the acceptable number of events and no other type of operation is planned, the heliport meets the recommended noise criteria.

(4) If the analysis indicates marginal acceptability, use of the more detailed method (paragraph 17) may be necessary. A proposal may be considered marginal if the proposed number of events is within ten percent of the recommended maximum.

c. Multiple Routes and/or Helicopters. If there are several routes and/or a mix of helicopters, the sum of the operations can be evaluated for each noise sensitive location as follows:

(1) Using the single route, single helicopter procedure above, determine the recommended maximum number of events affecting each noise sensitive location for each route, direction, and type of helicopter.

(2) For each combination in Step 1, divide the number of proposed events by the recommended maximum number of events. This gives the acceptability ratio for each combination.

(3) Sum the acceptability ratios for all the combinations to obtain the noise loading (L). If the value of L is equal to or less than 1.0, the heliport meets the recommended criteria.

Note: This method is adopted from the current Occupational Safety and Health Administration rule. (Department of Labor Occupational Noise Standard, Code of Federal Regulations, Title 29, Chapter XVII, Part 1910, Subpart G, 36 FR 10466, May 29, 1971.) The determination of sound loading (L) is for one noise sensitive location only. It is to be computed for each location considered noise sensitive. The computed sound loading at each location is independent of the others; they can not be added.

TABLE 2  
RECOMMENDED MAXIMUM NUMBER OF EVENTS

DIFFERENCE BETWEEN HELICOPTER SOUND EXPOSURE LEVEL (1) AND COMMUNITY SOUND LEVEL (EQL)	AVERAGE NUMBER OF EVENTS PER <u>HO</u> UR	AVERAGE NUMBER OF EVENTS PER <u>DAY</u>
17	72	
20	36	
23	18	
26	9	
29	4.5	
31		64
34		32
37		16
40		8
43		4
46		2

(1) When measured data are used, this value is the arithmetic average of approximately 6 events.



17. DETAILED PROCEDURE.

a. Background. The mathematical formula for the 24-hour average equivalent sound level (EQL) takes several forms, depending upon the sources which are to be energy averaged:

(1) Identical events, such as a single helicopter flown several times a day over the same route -

$$L_{eq} = 10 \log \frac{N \times 10^{L_{AE}/10}}{86,400} \quad (1)$$

where

$L_{eq}$  = average equivalent sound level

$N$  = number of daily helicopter events

$L_{AE}$  = sound exposure level of each helicopter event in decibels A-weighted

86,400 = number of seconds in 24 hours.

(2) Dissimilar events, such as different helicopter types flown over one or more routes or the same helicopter using several procedures or routes -

$$L_{eq} = 10 \log \frac{1}{86,400} (10^{L_{AE_1}/10} + 10^{L_{AE_2}/10} + \dots) \quad (2)$$

where  $L_{AE_1}$ ,  $L_{AE_2}$ , etc. are the individual single-event sound exposure levels in decibels.

(3) Combinations of the above, such as several events of different helicopter types or different procedures -

$$L_{eq} = 10 \log \frac{1}{86,400} (N_1 \times 10^{L_{AE_1}/10} + N_2 \times 10^{L_{AE_2}/10} + \dots) \quad (3)$$

where  $N_1$ ,  $N_2$  etc. are the number of single events at sound exposure levels  $L_{AE_1}$ ,  $L_{AE_2}$ , etc.

b. Methodology. A process similar to that used in the simplified method is used here, except that the appropriate formula from 17(a) is used to compute the average equivalent sound level (EQL). This value of EQL is then compared against the normally compatible sound levels in Table 1. Again, it is recommended that the helicopter average equivalent sound level not exceed the community EQL. An example calculation using the detailed method is shown in Appendix 1.

18. COMPARISON OF SIMPLIFIED AND DETAILED METHODS. The simplified method uses the normally compatible community sound level from Table 1 or from measurements to determine a recommended maximum for the average number of events per hour. The detailed method computes the helicopter EQL for comparison to the existing community EQL. Both methods use single-event sound exposure level data from Report FAA-EE-82-16 or from measurements.

19. ELEVATED HELIPOINTS. In general, elevated heliports, such as those on top of buildings, are evaluated by either method in the same way as grade level heliports. However, care should be taken to use the correct single-event sound exposure levels. The slant range is the direct line-of-sight distance from the noise sensitive location to the heliport atop the building, not the horizontal distance along the ground.

20. SOUND MEASUREMENTS. While an acoustic measurement program can be undertaken to provide all or part of the data used in the assessment procedures of this advisory circular, such programs are often difficult, expensive and time consuming. Therefore, they should be undertaken only after all practical analytical assessments have been made. These assessments should have taken into account the many variables affecting the sound level of the helicopter and the peculiarities of the heliport application. If measurements are still deemed necessary, they should be made in the designated noise sensitive areas using the proposed helicopter route(s), flight profile(s), and model(s). The option of measuring community ambient, energy-averaged, sound levels (EQL) requires 24-hour monitoring over long periods to account for daily, weekly and seasonal variations. This usually requires specialized equipment and often specially-trained personnel. In evaluating helicopter sound levels attributable only to the helicopter, extraneous noise must not influence the data. Guidelines for the measurements are as follows:

a. The integrating sound level meter used for measurements must be calibrated and set to read sound exposure level. The sound level meter used must meet or exceed American National Standards Institute (ANSI) specifications for sound level meters, Standard S1.4-1983 or the most recent revision thereto.

b. Personnel performing the measurements must have been trained in use of the equipment and in techniques required to obtain valid sound levels. It is important that the methods of data acquisition are consistent and accurate so that all cases are evaluated on the same basis.

c. Care should be taken to ensure that the helicopter sound data are not contaminated with sound from other sources and that the sound exposure level (SEL) is a true indication of the sound generated by the helicopter alone.

d. Wind speed at the microphone should not exceed 15 knots during the measurement. A windscreen should be used for all outdoor measurements and any sound level corrections necessary to account for windscreen attenuation should be made.

e. The microphone of the sound level meter should be about 4 feet above the ground and at least 25 feet from the nearest building or structure.

f. The helicopters should use the landing and/or takeoff techniques proposed for use at the heliport.

g. At least six repeat flights are recommended. The data are to be arithmetically averaged to give a mean sound exposure level. (Note: In the case where the pilot has no experience using the proposed heliport site, practice landings and takeoffs should be allowed.)

#### SECTION 5. REMEDIAL ACTIONS

21. ALTERNATIVES. If analyses or measurements indicate the environmental criteria are not met, the heliport applicant may choose to modify the proposal in order to meet them. Such modification may include one or more of the following alternatives:

- a. Selection of different ingress/egress routes.
- b. Adoption of specific noise abatement piloting techniques.
- c. Relocation of the heliport/helipad on the property further away from a noise sensitive facility or area.
- d. Construction of a second heliport/helipad on the site to distribute noise loading between noise sensitive facilities or areas.
- e. Erection of barriers to reduce sound propagated into neighboring areas.
- f. Using existing buildings to shield noise from sensitive areas by relocating the heliport/helipad.

Other modifications to the heliport plan may be possible depending on the particular site, terrain and local conditions. These should be thoroughly studied by all parties involved to arrive at a mutually satisfactory heliport plan. Analyses or measurements should then be repeated with the agreed modifications.

This aspect is of particular importance in the case where noise measurements are made during an initial trial demonstration at the proposed site, since the normal operating techniques used may not take full advantage of the helicopter's operational flexibility to further reduce sound levels.

APPENDIX 1. EXAMPLE OF DETAILED HELICOPTER  $L_{eq}$  CALCULATION

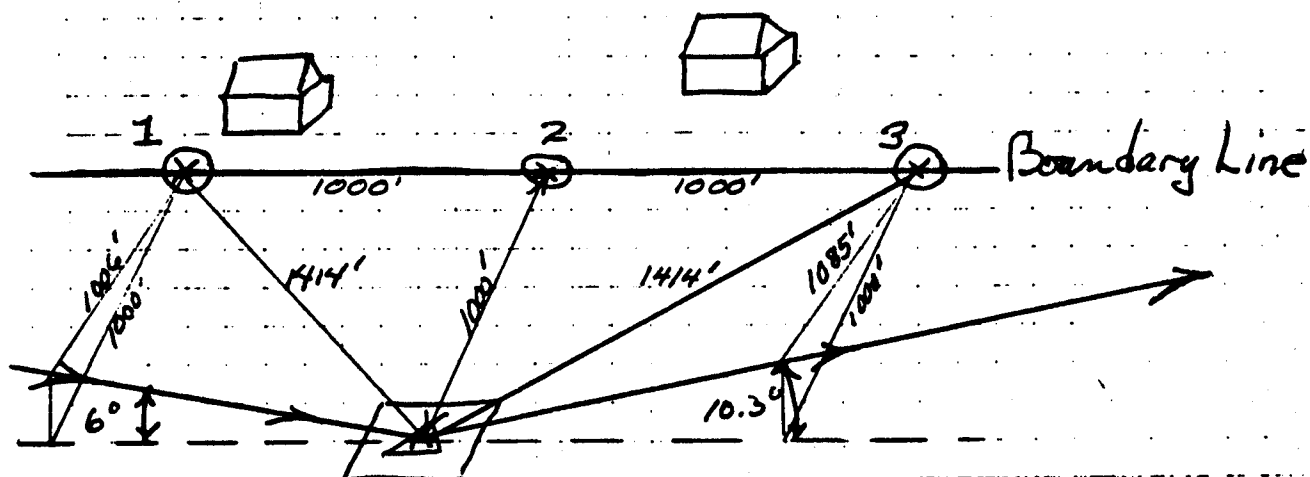

**EXAMPLE CALCULATION OF HELIPORT NOISE EXPOSURE LEVEL:**

Assume a proposed heliport located 1,000 feet from the boundary of a suburban residential area, as shown above. It is proposed that 12 flights per day, during daytime hours, be permitted by Sikorsky S-76 helicopters, following the flight paths shown. Available noise data are taken from Report FAA-EE-82-16.

At Point #1:

L (approach) @ 1,006'	85.8 decibels
L (takeoff) @ 1,414'	81.4 decibels

$$L_{eq}(\text{helicopters}) = 10 \log \left( \frac{12}{86,400} (10^{8.58} + 10^{8.14}) \right)$$

$$= 48.7 \text{ decibels}$$

At Point #2:

L (approach) @ 1,000'	85.8 decibels
L (takeoff) @ 1,000'	83.8 decibels

$$L_{eq}(\text{helicopters}) = 49.3 \text{ decibels}$$

At Point #3:

L (approach) @ 1,414'	84.3 decibels
L (takeoff) @ 1085'	85.2 decibels

$$L_{eq}(\text{helicopters}) = 50.0 \text{ decibels}$$

From Table 1, the normally compatible sound level (EQL) for a suburban area is 57 decibels. Since the computed helicopter EQL is 50 decibels or less along the boundary, the proposed heliport would meet the recommended guideline.

## CHAPTER 4. SELECTING A HELIPORT SITE

40. GENERAL. Increased public awareness of helicopter capabilities has enhanced its prominence as an important vehicle in the national transportation system. Continuing advances in helicopter productivity and operating economics make it reasonable to anticipate increasing public and private usage for intra- and interarea transportation. However, optimum public benefits cannot be realized without an adequate system of public-use heliports. Stage development is encouraged when it is unnecessary or uneconomical to construct the ultimate heliport. Early coordination with FAA Airports offices on adequacy of the proposed stage construction and ultimate design of the heliport and with FAA Flight Standards offices on operational procedures and limitations is encouraged.
41. LOCATION. To be most effective, heliports should be located as close as conditions or circumstances permit to the actual origins and destinations of the potential users. In some communities, this might require a heliport to be located in an area that could be described as congested or highly developed. In many instances, a practical, safe, and economical ground-level heliport can be established on a portion of an automobile parking lot that is fenced off to control access. If a ground-level site is unavailable, it is possible to locate the heliport on the roof of a building or on an unused pier or wharf. Elevated or overwater heliport sites will have in many instances an advantage over ground-level heliport sites since public access can be more easily controlled and unobstructed approach-departure paths may be easier to obtain. Other considerations in heliport siting are the locations of populated areas, noise-sensitive developments, and the existence of objects in the proposed approach-departure paths.
42. LAYOUT. The physical layout of the heliport is primarily dependent upon the operating characteristics of the helicopters to be accommodated and the type of support facilities desired. A relatively modest site will suffice if a minimum takeoff and landing facility capable of accommodating one small helicopter is all that is desired. Even though helicopters can maneuver in relatively high crosswinds, the approach-departure paths should be oriented to permit operations into the prevailing winds.
43. HELIPORTS AT AIRPORTS. The location and extent of separate takeoff and landing facilities to serve helicopter operations will vary from airport to airport. Most airports would probably find it advantageous to establish facilities and procedures to separate helicopter and airplane traffic. These helicopter takeoff and landing facilities may be developed on a portion of the apron or on an infield site adjacent to an apron or taxiway. When helicopters are scheduled to connect with airline flights, the helicopters should be allowed to board and discharge passengers in close proximity to the airline check-in areas.

8/22/77

To the extent possible, locate facilities to avoid mixing helicopter operations with airplane operations. Clearance between the helicopter takeoff and landing facility and the airport's active runway(s) should be in accordance with the heliport-to-runway separations of Figure 4-1.

44. TRANSPORTATION STUDIES. The proponent of a public-use heliport should review all transportation studies for the area. These studies frequently identify area origin-destination patterns and provide descriptions of existing and proposed public transportation systems. The studies may also describe existing and projected land development patterns for commercial, industrial, public, and residential usage and zoning actions taken to permit or to encourage such usage. Some studies may have identified tentative public-use heliport locations. Communities planning urban renewal projects may find the inclusion of a public-use heliport to be the catalyst needed to attract desirable commercial or industrial development.
45. OPERATIONAL SAFETY. A major consideration in heliport siting is the availability of suitable approach-departure paths. It is preferable for helicopters to make takeoffs and landings into the prevailing winds but in some situations this may not be possible. In congested areas it may not be possible to develop a straight-in approach or departure procedure and a curved approach-departure path may be necessary to avoid obstacles. In other situations special letdown and climbout procedures may be desired to confine helicopter sounds to a small area near the heliport. Helicopter approach or departure procedures are developed for each heliport on the basis of site conditions, helicopter capabilities, and the type and number of activities to be conducted therefrom. When necessary, the FAA may condition an airspace decision by requiring special flight routes, altitudes, or approach and departure procedures in the interest of user safety and airspace compatibility.
46. LOCAL REGULATION. Because helicopters can operate safely at sites of limited size, it is quite likely that heliports may be suggested for areas that have not been exposed to significant aviation activity. Consequently, the heliport proponent may have to take a substantial and active role in educating the public about heliports and helicopters.
  - a. Local Laws. The rules, regulations, and ordinances (collectively called local laws) which control airport development may impose restrictive conditions which would be inappropriate when applied to heliport proposals. It is not intended to suggest that any community will have to revise its local laws; however, some laws may need to be reexamined when heliport development is under consideration. Helicopter operators, manufacturers, industry associations, state aviation authorities, and the FAA should be contacted for advice before laws which regulate heliports are initiated or changed.

- b. Land-Use Zoning. Zoning ordinances should be written to permit heliports as an accepted land use in areas identified for industrial, commercial, manufacturing, or agricultural uses and in any area that is unzoned. Some heliports, especially those without support facilities, could be a permitted use in certain residentially zoned areas. Language that permits occasional or infrequent helicopter landings at a site that is not a formally designated heliport should be encouraged.
- c. Height Restriction Zoning. The desire for clear approach-departure paths is an important consideration in selecting a heliport site. When state-enabling legislation permits, communities are encouraged to protect heliport approach and departure paths by enacting height restriction zoning. Advisory Circular 150/5190-4, A Model Zoning Ordinance to Limit Height of Objects Around Airports, contains general guidance for preparing an ordinance restricting the height of objects around a heliport.

47. ENVIRONMENTAL AND OTHER CONSIDERATIONS. The establishment of a heliport may have an impact on the community in terms of noise, exhaust emissions, public safety, ground traffic, aesthetics, and attitude. When Federal aid is used, an environmental impact assessment report is required to assist the Federal agency in making the environmental decision. A similar report may be required by state or local authorities.

- a. Noise. The impact of helicopter engine and rotor sounds upon populated areas is an important consideration in selecting a heliport site. Since helicopter sounds are greatest directly beneath the takeoff and landing paths, these paths should be located over sparsely populated areas; over areas that have an already high level of background sounds; or over areas that would be expected to have a high tolerance level to helicopter sounds. Improvements resulting from ongoing research activities to reduce the sounds generated by engines and rotors will be incorporated in future helicopters as quickly as economic and technological conditions permit.
- b. Exhaust Emissions. Relatively few civil-use heliports have sufficient flight operations for exhaust emissions to be considered a significant problem. Research on aircraft fuels and engines to reduce pollutant levels will also be applicable to helicopters.
- c. Public Safety. Heliport sites and approach-departure paths should be selected to avoid areas of public concentration. The approach-departure paths should also be free, and capable of being maintained free, of objects that interfere with helicopter movement to and from the heliport.

- d. Ground Traffic. Potential problems with passenger ground ingress or egress to a heliport may be minimized if there is direct access to an adjacent major roadway. Access to one or more modes of public mass transit is desirable. A heliport in a freeway environment has some inherent advantages over other sites. First, helicopter sounds may be undetectable over the existing background noises. Second, approach-departure paths can frequently follow the freeway right-of-way which is generally unencumbered with objects that would be hazardous to flight safety.
  - e. Aesthetics. Community acceptance of ground-level heliports can be enhanced if the facility has an attractive appearance. Attractive buildings and carefully planned walls, fences, hedges, etc., are to be encouraged.
  - f. Attitude. Community acceptance or rejection of a heliport site proposal is difficult to predict. An opportunity for a public hearing to obtain citizen input is required for Federal aid projects. A well prepared presentation to citizen groups on the positive and negative aspects of the proposed heliport together with patience, honesty, and an attitude of willing cooperation in responding to questions will help to influence public opinion.
48. PROJECT ACTIVITIES. Heliport proponents may find a checklist helpful in pursuing their objective. Any checklist must be developed to meet local conditions which will vary from one location to another. The following items are representative of the activities that are carried out in any heliport development and may be added to or subtracted from as the situation warrants.
- a. Review Regulations. Review local regulations of the city and county concerning land usage, building codes, aircraft operations, noise limits, fire protection, etc., for possible impact.
  - b. Select Sites. Select potential sites which would not be subject to zoning restrictions, will provide ample room for current and future needs, and will have clear approaches.
  - c. Seek Advice. Contact appropriate Federal and state aviation offices, local helicopter operators, aviation consultants, or helicopter manufacturers as to the operational feasibility of the sites being considered, including approach-departure paths and operating procedures.



- d. Submit Notices. Submit required notices and applications to appropriate Federal, state, and local agencies. If a variance of a local zoning ordinance is needed, provide sufficient details in the request to answer probable questions about intended operations.

49. RESERVED.

# HOW TO OPERATE THE LIGHT HELICOPTER MORE QUIETLY

Prepared by

C. R. Cox  
Research Project Engineer

When you start operating a light helicopter in new territory, you add a new spectrum of sound to the usual noise environment. If that territory is a municipality, thousands of people will hear the new sounds and know where they are coming from. How they will react depends upon many complex physical, economic, and psychological factors, but one thing is certain: They will react strongly, adversely, and actively if the sound is too irritating, if it represents something that seems to threaten their safety and well-being, or if they cannot see how the noisemaker benefits them. Although it is up to the operator to educate the public about the safety and usefulness of the helicopter--and to equip his aircraft with sound-suppressing devices when these are available and needed--the pilot can make the public less hostile to the helicopter (and to the operator's arguments about its safety and community service) by flying in such a way as to make the sound of his aircraft as uniritating as possible.

Figures 1 and 2 show the trend of helicopter noise levels and where the light helicopter (5000 pounds gross weight or less) fits into the overall noise picture. The units of the vertical scales represent, to some extent, the degree to which a sound will annoy the average human listener. We can't say what sound level will make the housewife, school teacher, or hospital patient complain to the authorities. Instead, we show on the figures the sound level of a diesel locomotive and a truck or motorcycle. You can compare this with the sound of the helicopter and draw your own conclusions.

Notice that the noise level of a light helicopter is a function of the type of power plant. Turbine-powered helicopters are quieter than piston-powered ones with unmuffled engine exhausts and produce sounds no louder than those of familiar surface transportation vehicles.

Notice also that the noise level of a helicopter at a given gross weight covers a range. This is true not only for helicopters in general, but also for a particular helicopter--the particular one you may find yourself flying, for example. What you need to know is how you can fly that helicopter, given a certain gross weight, in the lower portion of this range of sound levels--at least when you are flying near people whom noise might bother. This write-up tells you about the conditions which produce the higher noise levels during the operation of light turbine-powered helicopters such as the Bell Model 206A, and describes flight techniques which will help you to avoid them. It also discusses methods to muffle the sound of light piston-powered helicopters such as the Bell Model 47. A companion write-up contains similar information for medium helicopters.

### THE SOURCE OF THE SOUND

The acoustical signature of a helicopter is partly due to the modulation of sound by the relatively slow-turning main rotor. This modulation attracts attention, much as a flashing light is more conspicuous than a steady one. The modulated sound is often referred to as "blade slap." For a typical light helicopter, blade slap occurs during partial power descents, when a blade intersects its own vortex system or that of another blade. When this happens, the blade experiences locally high velocities and rapid angle-of-attack changes. This can momentarily drive a portion of the blade into compressibility and possibly shock stall, both of which produce aerodynamic loading variations. Either or both mechanisms generate sound.

Figure 3, a chart of blade slap regions as functions of airspeed, rate-of-climb (R/C), and rate-of-descent (R/D), shows where you can expect the Model 206A to produce this sound. Maximum blade slap occurs at airspeeds between 75 and 95 mph and rates-of-descent between 300 and 600 fpm. The "slap boundary" for your particular helicopter may be somewhat larger than that shown because the main rotor may slap intermittently when it encounters wind gusts or if you transition rapidly from one flight condition to another. Although the sound produced at these descent rates is not extremely loud to crew members inside the helicopter, they can recognize it easily and define the slap boundaries for their particular helicopter. Of course, people on the ground hear slap increase in intensity as the helicopter descends.

## HOW TO MINIMIZE NOISE

In general, you can eliminate the most offensive sounds of the 206A helicopter by keeping it out of the slap region shown in Figure 3. This is not always possible, of course, and when the slap regions cannot be avoided, they should be flown through as quickly as possible. There are also other methods of reducing helicopter noise, and you should use them when you can, whether you are flying in a slap regime or not.

### Routes and Airspeeds

1. Fly at highest practical altitude during approach to metropolitan areas.
2. Select route into terminal over least populated area.
3. Follow major thoroughfares or railway roadbeds.
4. Avoid flying low over residential and other densely populated areas.
5. If you must fly over such areas, maintain a cruise speed of approximately 110 mph.
6. Select the final approach route with due regard to the type of neighborhood surrounding the terminal and the neighborhood's sensitivity to noise. Assess this sensitivity beforehand for each terminal. Some of the guidelines are:
  - a. Approach keeping the terminal between the helicopter and the most noise-sensitive building or area.
  - b. If the terminal is surrounded by noise-sensitive areas, approach at the steepest practical glide slope.
  - c. Avoid flying directly over hospitals, nursing homes, schools, and other highly noise-sensitive facilities.
  - d. If the terminal is in or near a noise-sensitive area, use the noise-abatement approach and landing technique described below and illustrated in Figure 4.

## Noise-Abatement Approach and Landing

1. When commencing approach, follow one of these two procedures:
  - Establish a rate-of-descent of at least 500 fpm before reducing airspeed, then reduce airspeed while increasing rate-of-descent to at least 800 fpm, or
  - Hold rate-of-descent to less than 200 fpm while reducing airspeed to about 65 mph, then increase rate-of-descent to at least 800 fpm.
2. At a convenient airspeed between 60 and 90 mph, set up approach glide slope while maintaining the 800-fpm or more rate-of-descent.
3. Increase rate-of-descent if the main rotor tends to slap, or if you want a steeper glide slope.
4. Approaching the flare, reduce airspeed to below 70 mph before decreasing rate-of-descent.
5. Execute normal flare and landing, decreasing rate-of-descent and airspeed appropriately.

The basic difference between this approach technique and a normal one is that this one avoids the slap regime. Both procedures give approximately the same airspeed during the approach, with the quieter technique using a glide slope which is a few degrees steeper. Once the pilot has transitioned from cruise to the approach glide slope, he can tailor his airspeed and rate of descent to fit local conditions, avoid unsafe regimes, and still guarantee minimum noise.

## Departure

Takeoffs are reasonably quiet operations, but you can limit the total ground area exposed to helicopter sound by using a high rate-of-climb and making a very smooth transition to forward flight. Your departure route should take you over areas which are the least sensitive to noise.

## Maneuvers

Avoid rapid, high g turns, as a general rule. When the flight operation requires turns, perform them smoothly. Be smooth in all other maneuvers, also.

## MUFFLING

The engine noise of the piston-powered helicopter may be its loudest or most annoying sound, especially if the pilot uses the noise-abatement flight techniques to reduce blade slap. The best way to reduce the amount of sound coming from a piston engine is to install a muffler on it. Mufflers, however, impose penalties on the helicopter and increase its operating cost. The question then becomes one of how little muffling (how small a penalty) will make the helicopter socially acceptable for a given operation. This depends on how close the helicopter's operations take it to populated areas, the background noise levels in those areas, and how sensitive they are to noise. Figure 5 shows the intensities of various background noise generators, and the range of sound intensities emanating from piston-powered helicopters.

The operator, of course, wants to use the lightest, cheapest muffler that will keep him out of trouble. If his operations are in remote, sparsely populated areas, or in areas of medium to heavy surface traffic, he probably will not need any mufflers. If unmuffled operations bring sporadic complaints, then he will want a light muffler--perhaps one that can be installed and removed easily, and used only on those missions which take the helicopter close to sensitive areas. Operations in densely populated residential districts or which occur during the quiet hours of the night may require fairly heavy muffling.

The light muffler may be mounted directly on the exhaust stacks. It reduces noise by an order of magnitude while penalizing the performance of the helicopter only slightly. It removes the objectionable "barking" sound which is characteristic of unmuffled piston engines.

A larger muffler has to be mounted on the fuselage structure because the exhaust stacks may not support it and there is not always room for it on the stacks, anyway. Flexible metal hoses connect it to the exhaust stacks. Its mounts can be so designed that they will accommodate any one of a number of different mufflers, each to quiet the engine to a different level (and penalize it correspondingly).

As of this writing, there are several mufflers for piston-powered helicopters. (Bell has one, a stack-mounted muffler available as a kit for the Model 47.)

As the operator runs into more and more strenuous objections to his sound, he should look to mufflers as part of the answer. Helicopter manufacturers and independent companies have continuing programs to produce mufflers that will keep him in the good graces of his neighbors.

#### METEOROLOGICAL CONSIDERATIONS

Although the pilot cannot control the weather, he may be able to adapt his flight schedule to take advantage of meteorological conditions which can help him to minimize noise. The two weather factors which are most useful in this respect are wind and temperature. They are helpful because they vary throughout the day (diurnally) in a more-or-less predictable manner, and affect the propagation of sound.

Wind has two effects on sound. It carries it in the direction toward which it is blowing, and it makes a background noise of its own which, in high winds, tends to reduce the annoyance factor of the sound of a helicopter. In inland areas, surface winds generally are stronger during the daytime (maximum in midafternoon) and weaker at night. In coastal regions, land and sea breezes (caused by the tendency of land to heat and cool more rapidly than water) give a different diurnal pattern, beginning to blow shortly after sunrise (sea breeze) and sunset (land breeze). You can use these winds to increase the acceptability of your helicopter by flying downwind of densely populated areas and by scheduling after noon the majority of flights near especially noise-sensitive areas.

Temperature likewise has two effects upon sound. One is the tendency of warm air to be more turbulent than cold air and therefore to disperse sound and decrease its nuisance effect. But the major effect of temperature depends upon the temperature gradient--the change in temperature with altitude. The normal gradient is negative--temperature decreasing with altitude. Because sound travels faster in warmer air, in atmosphere with the normal gradient the lower part of a sound wave tends to outrun the upper part, making the propagation, in effect, curve upward and away from the populace. The negative gradient reaches a maximum in the late morning or just after noon, and is more intense during summer months. This means that it is of some value to schedule flights to and from noise-sensitive areas during the warmer parts of the day.

At certain times, however, there may be an inversion in the atmosphere--a layer of air from a few hundred to a few thousand feet thick in which the temperature increases with altitude. The inversion reverses the normal "curvature" of sound propagation, turning an abnormally high portion of the sound energy back toward the ground. The most severe inversions usually occur at night and in the early morning. These, then, are the times when the sound of the helicopter will have the most adverse effect upon people on the ground.

A third meteorological item that affects the propagation of sound is humidity. But its direct effect is of little importance (it attenuates high frequency portions of the sound spectrum). As visible moisture, it is important as an indicator, in that on overcast days of fog, drizzle, or light snow, temperature and wind gradients are generally small, resulting in increased sound propagation. Of all the many combinations of atmospheric conditions, that which does least to reduce the sound of a passing helicopter is the combination of no wind and an overcast on a cold morning. It is most important that at these times you use the noise-abatement flight techniques.

Although environment is hardly a meteorological subject, it might be well to mention here that the ground environment has much to do with the offensiveness or lack of offensiveness of the sound you make. The background noise level or sound environment of residential areas reaches its lowest point between late evening and early morning. In warm weather, people are apt to be relaxing out-of-doors in the evening and on week-ends. It is at these times that the citizen is most conscious and resentful of noise intrusion, and therefore at these times that you should be most reluctant to fly noisily near residential areas.



FIGURE 1

TREND OF HELICOPTER NOISE LEVELS (dba UNITS)

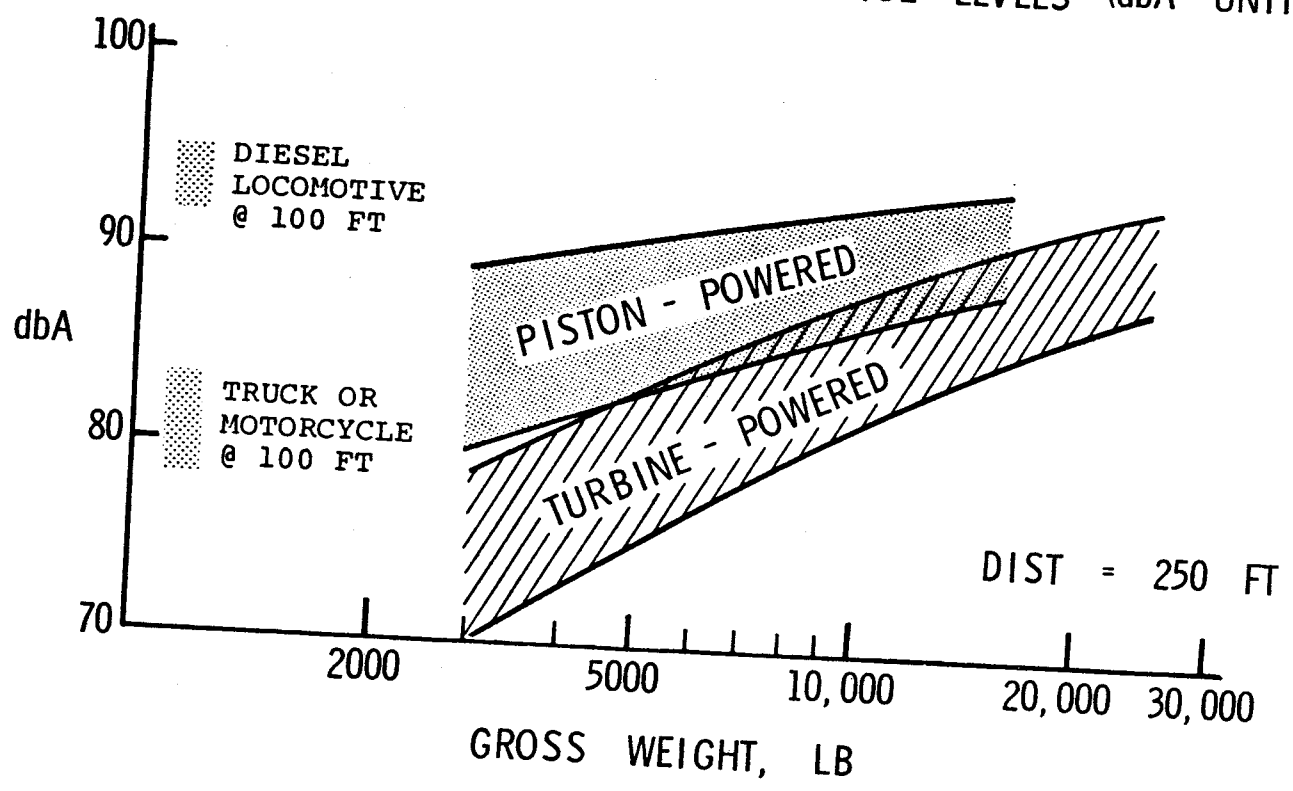

- 8 -

FIGURE 2

TREND OF HELICOPTER NOISE LEVELS (PNdb UNITS)

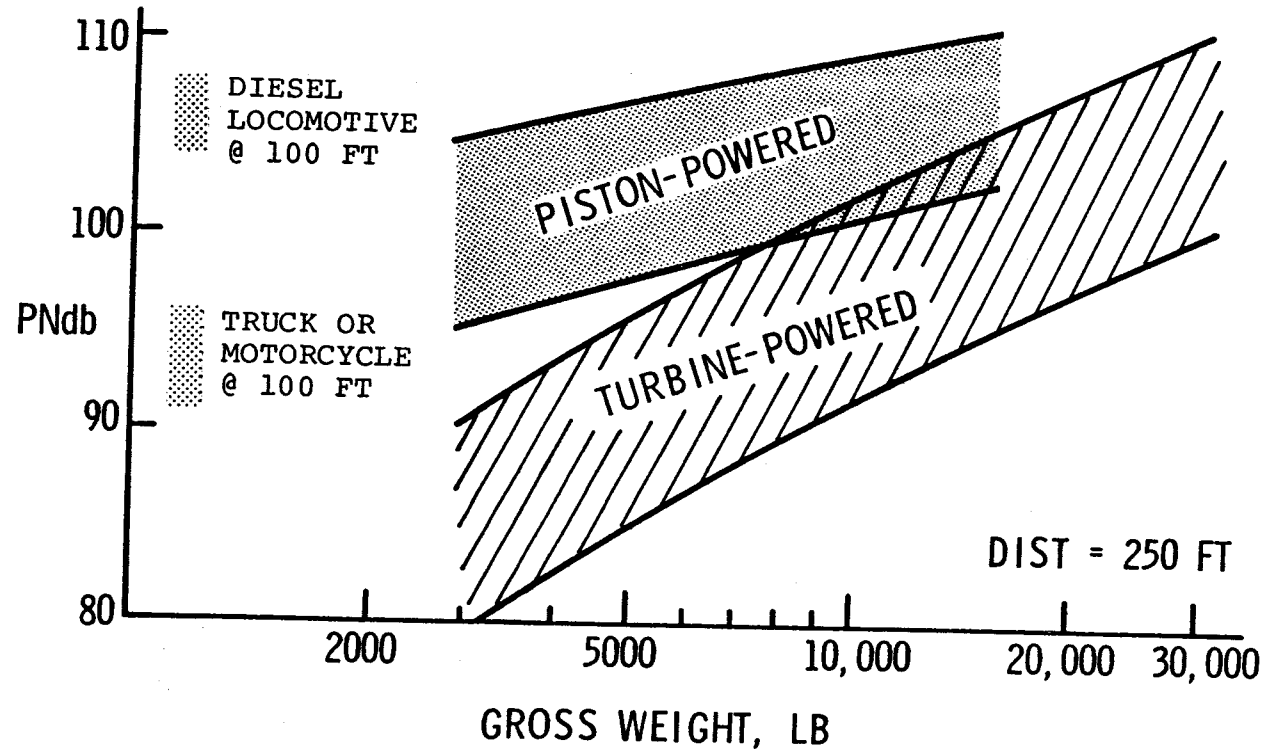

FIGURE 3  
NOISY FLIGHT OPERATIONS--LIGHT HELICOPTERS

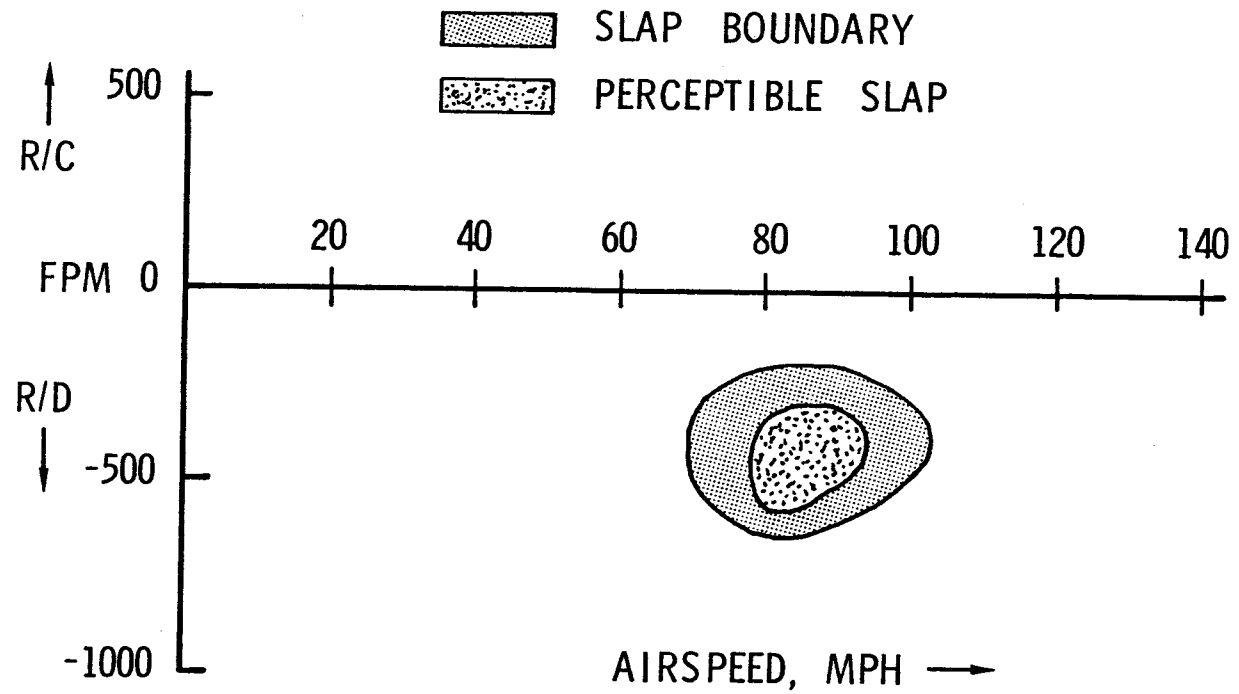

FIGURE 4  
NOISE - ABATEMENT FLIGHT TECHNIQUE--LIGHT HELICOPTER

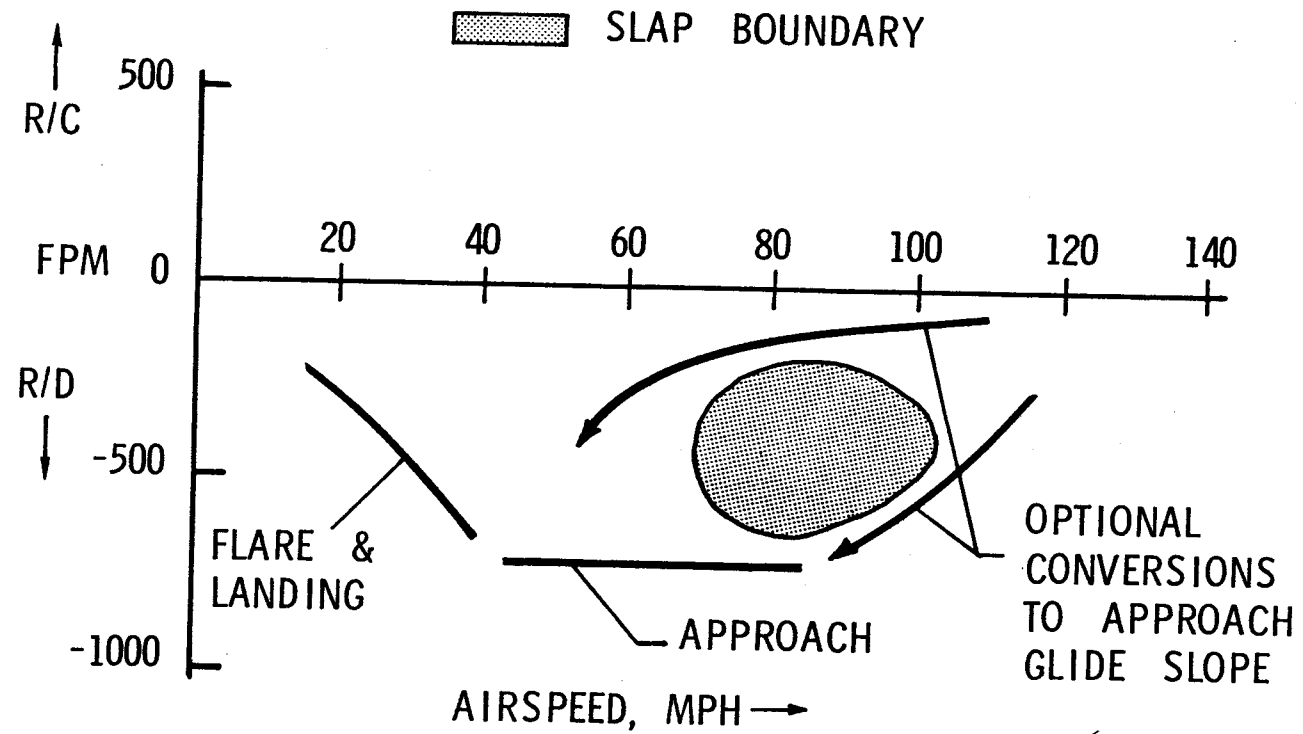
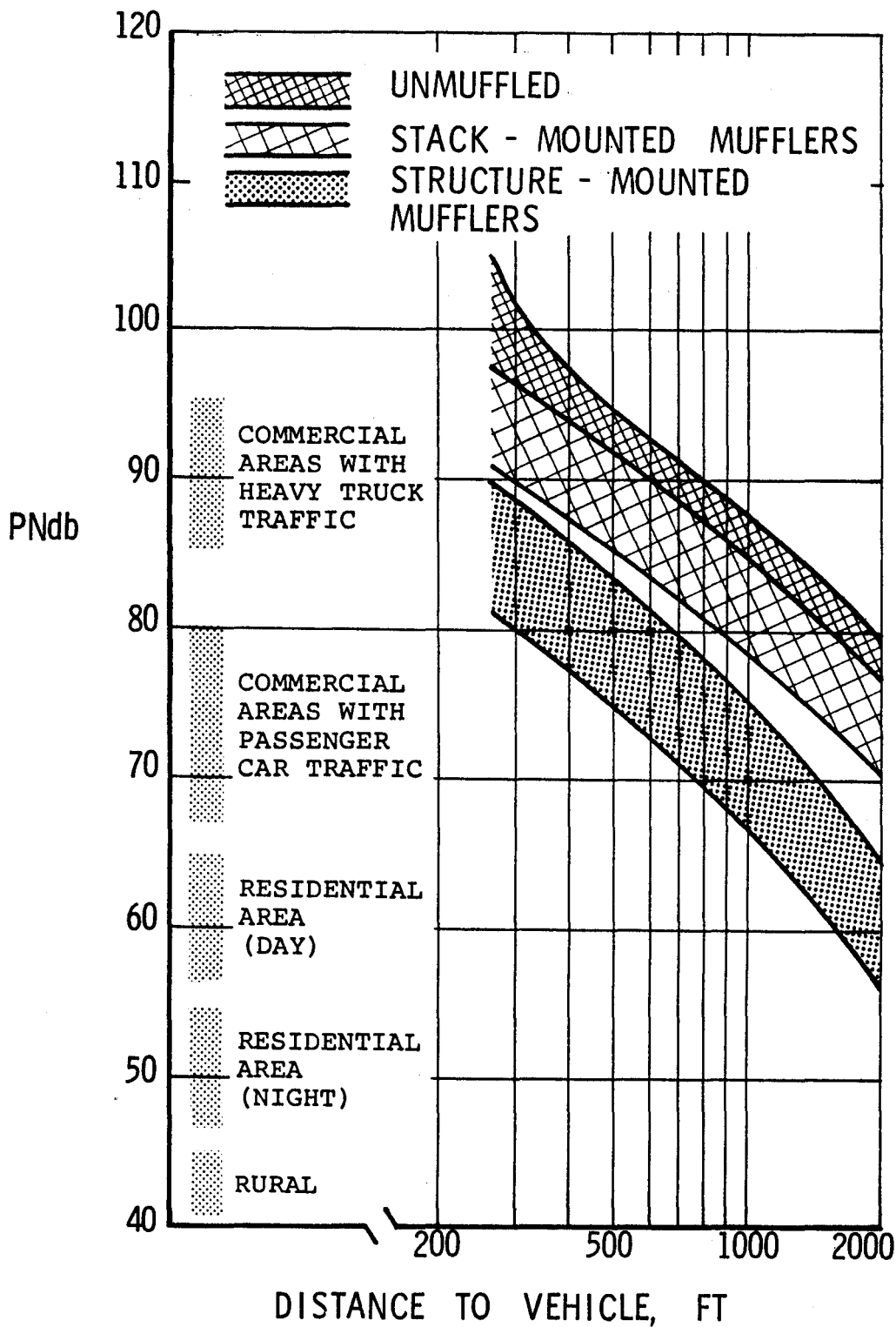
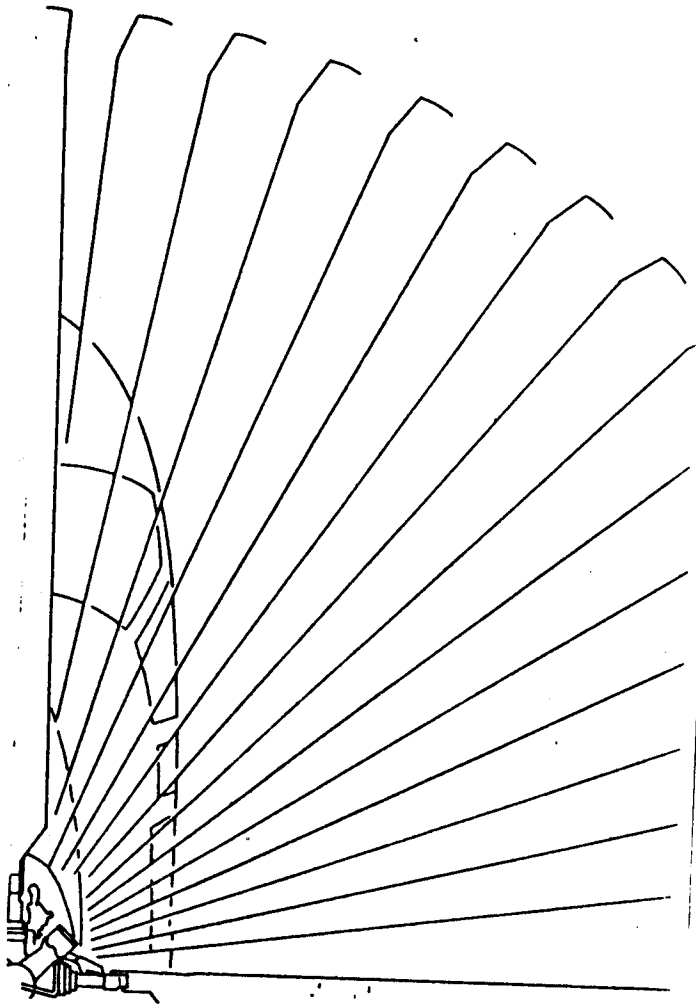

FIGURE 5

EXHAUST NOISE SUPPRESSION OF  
LIGHT PISTON - POWERED HELICOPTERS



# The facts of helicopter noise



Noise, a primary consideration in urban aircraft operations, may become the single deciding factor in a municipality's acceptance of a public-use heliport.

"How much noise does a helicopter make?" and "How do people react to this noise?" These questions need answers before a decision on building a heliport can be made.

Helicopter noise comes primarily from its rotor blades. It is different than most other city sounds and sometimes is thought to be louder than it actually is.

A scientific rating of a sound signal is called Perceived Noise Level. Calculated from acoustical measurements, it is computed from sound pressure levels measured in frequency bands and expressed in Perceived Noise decibel units (PNdB).

These units are the translation of the subjective annoyance of the individual frequency bands into a single number expressing the

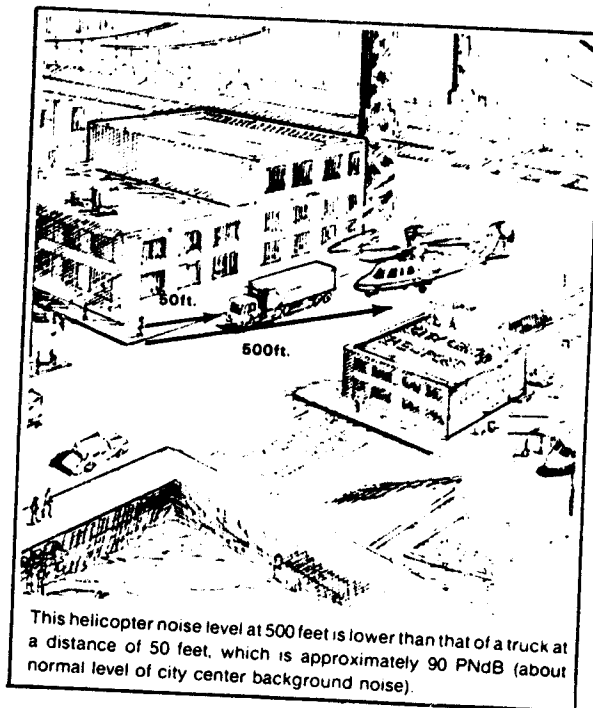

This helicopter noise level at 500 feet is lower than that of a truck at a distance of 50 feet, which is approximately 90 PNdB (about normal level of city center background noise).

... FLY NEIGHBORLY ...

# The Tails and Rotors of Flying Neighborly

## Sources of Sound

The International Civil Aviation Organization (ICAO) has adopted noise abatement standards and recommended practices in their publication on environmental protection.

From the development point of view, we must remain cognizant of this requirement and move to improve the ways we can use technology to serve our needs. From the practical point of view, we must reduce noise in every possible way.

What are some of the characteristics of noise that affect us? As you will see, knowing a little about this will enable you to defend yourself and others against harmful effects or the annoyance of noise. Take a close look at the charts illustrating sound level (below and on page 7).

The acoustical impact of a helicopter is, of course, a function of the size and type of power plant. Turbine-powered helicopters are quieter than piston-powered with muffled engine exhausts, and produce sounds no louder than familiar vehicles.

Blade slap occurs in the light helicopter typically during partial descent, when a blade intersects its own vortex system or that of another blade such as in formation flight. In the medium helicopter, this modulated sound occurs during high speed forward flight normally at air speeds over 100 knots, and during slow flight and turns.

## Meteorological Conditions

In addition to the physical relationship of the source of noise to the recipient, there are meteorological considerations that the sound-conscious pilot must know.







- Wind carries sound, so when possible fly downwind from potentially sensitive areas.
- Temperature has two effects upon sound. Warm air is more turbulent than cold air and disperses sound to reduce its nuisance effect. Sound travels faster in warm air. During normal temperature gradient, sound will propagate upward; however, during an inversion (where temperature increases with altitude) an abnormally high portion of the sound energy will be turned back toward the ground. The most severe inversions usually occur at night and in the early morning, so these are the times when your helicopter sounds will have the greatest effect upon people on the ground.
- Low cloud cover and low winds increase sound propagation. When there is visible moisture such as fog, drizzle or light snow, use noise abatement procedures.

## More Tails and Rotors

- Increase pilot knowledge, awareness and concern for environmental improvement.
  - Emphasize noise reduction.
  - Issue and become familiar with publications which provide noise abatement information, power settings, and flight maneuvers and techniques.
  - Condition aviators to practice 'good neighbor' flying.
- Some common noise attenuation methods are literally right at the fingertips of every helicopter pilot. We can reduce the length of hovering and proximity to building or individuals. Hovering requires power settings and consequently higher noise levels. Avoid low-level flying except under authorized circumstances.
- Develop discreet routes, approaches and approach procedures focusing on minimum exposure.
  - Enforce rules.
  - Support civil and military organizations to promote good neighbor practices.
  - Seek public acceptance by developing community awareness of the benefits of helicopters. Show concern for and a commitment to community problems. Dispatch people to measure decibel levels from which routes of helicopter may be altered. Although some of your noisier routes may remain, the community will appreciate your time, courtesy and consideration.
  - Work with local planners and cooperate to make helicopter facilities, operating hours, and flight routes as compatible as possible with the community.
  - Develop for each helicopter type (and model) the appropriate piloting techniques to reduce noise.

By Colonel John H. Boysen  
FNCS member

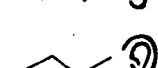
## Sound Comparisons

130 decibels	Threshold of pain.	
120 decibels	Airplane at ten feet. Hammering on steel plate three feet away.	
100 decibels	Riveting machine forty feet away. Tractor trailer starting up fifty feet away.	
90 decibels	Normal automobile horn twenty feet away. Subway, trolley 200 feet away.	
80 decibels	Loud radio music in home. Stenographic office sounds. Helicopter 400 feet away.	
70 decibels	Average conversation three feet away. Average city street sounds.	

From proposed City Code of Ordinance, Department of Health, Houston, TX. Chap. V, Sect. 1, Noise Rules, Levels, Recommendations, not dated, p. 63.

total annoyance of the combined signal. An increase of 10 PNdB in a sound is equivalent to doubling the noisiness and the annoyance of sound.

For example, a subsonic turbojet taking off at 700 ft. is measured as high as 118 PNdB; and a modern, twin-turbine helicopter like the Sikorsky 76 Mark II at 500 ft. in flight is only 90 PNdB, or about one-eighth the annoyance of the turbojet aircraft at a comparable distance.

Perceived Noise Level takes into account the pressure and the components of the sound. Surveys conducted in the United States and England have correlated Perceived Noise Levels with people's subjective judgments of the acceptability, annoyance and intrusiveness of sounds. The accompanying chart, "Subjective Judgments", shows such a relationship using some common sounds as examples. As you can see, people's reactions to the noise level of a helicopter have been shown by surveys to be

about equal to their reactions to other city-center background noises. They may notice the noise, but, in general, their reaction has been one of acceptance.

Another form of noise measurement and predictable reactions — called Noise Exposure Forecast (NEF) — is used by the government to rate community reaction to aircraft noise. An NEF value is determined by knowing not only the Perceived Noise Level, but also the number of noise exposures, their duration, and the number of times per day they occur. NEF values range from zero where community reaction to aircraft noise is negligible, to 25 where severe community resistance is likely to develop.

For example, the zero-NEF area for JFK International Airport, the giant jetport, is more than 400 square miles. The airport's 25-NEF area (where adverse community reaction is likely to develop) is 50 square miles. The 25-NEF area around a heliport usually is confined to the heliport itself.

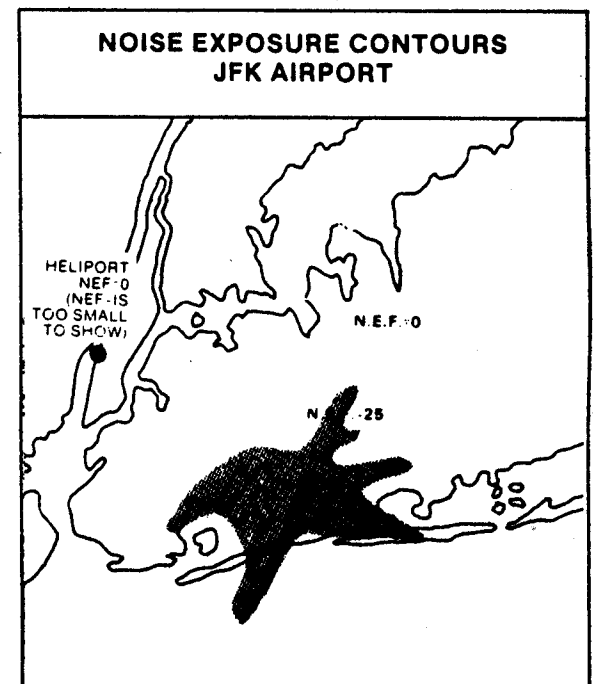
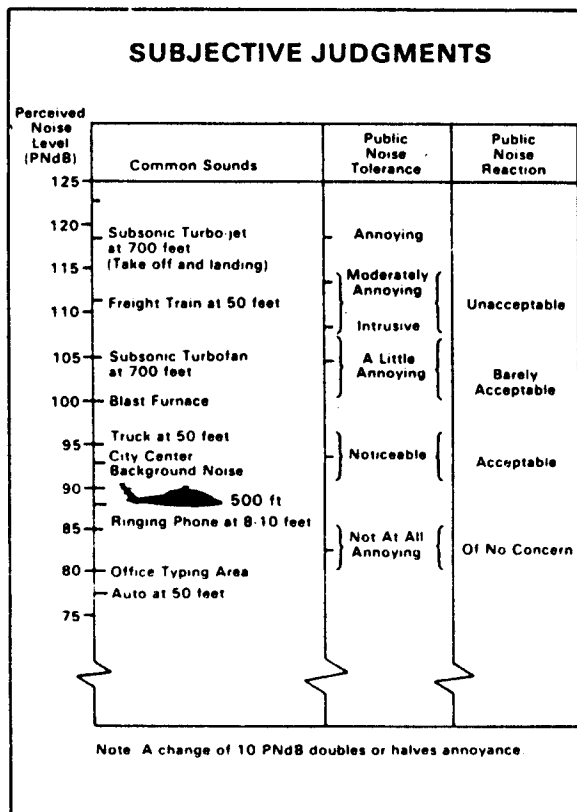

... FLY NEIGHBORLY ...

... FLY NEIGHBORLY ...



# COMPARISON OF SOUNDS

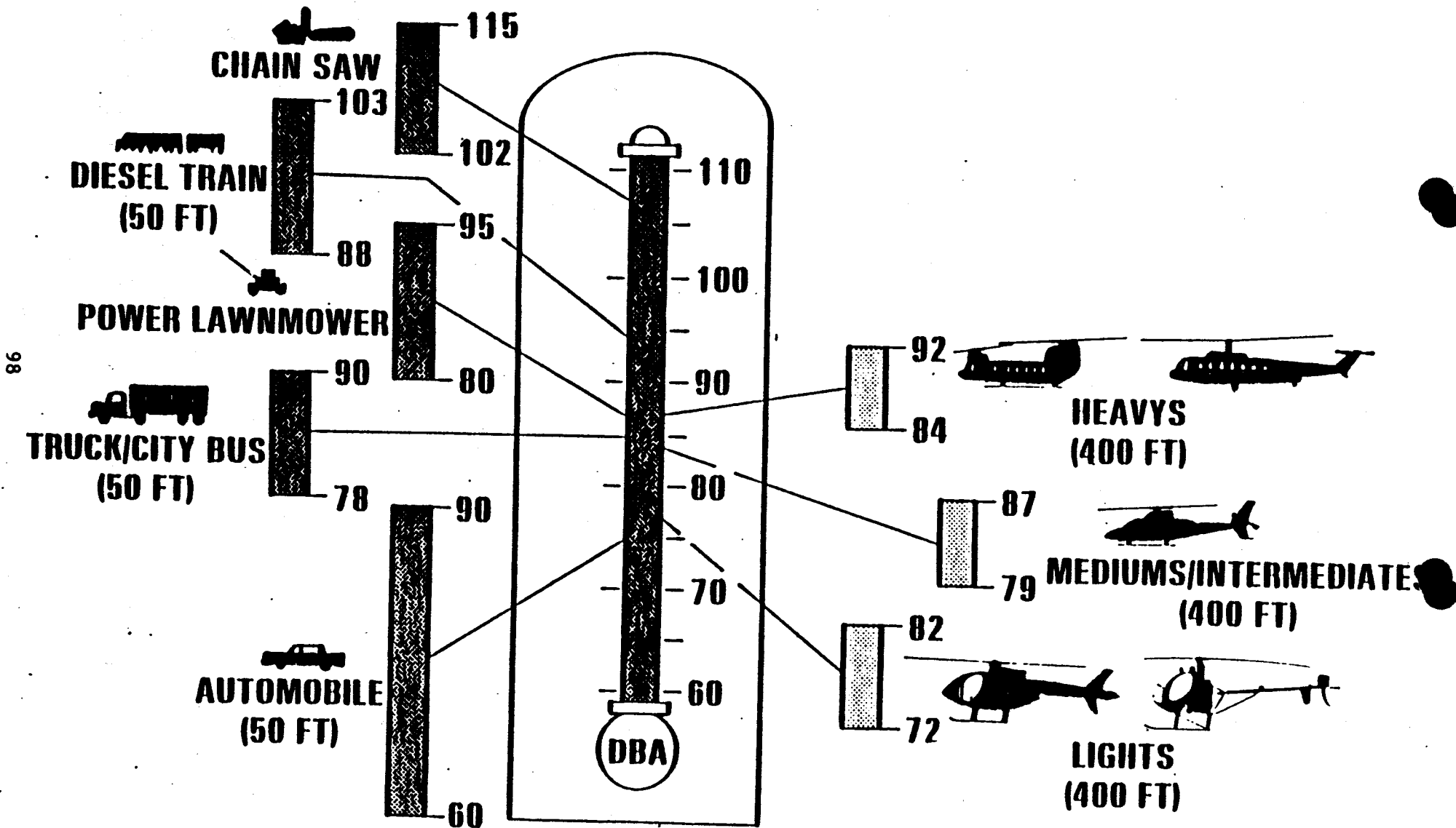

May 17, 1985  
Grand Junction, CO

Mr. Karl G. Metzner  
Planning Director  
City of Grand Junction  
Grand Junction, CO

Dear Karl:

Mountain Bell has just purchased a Bell 20623 helicopter which will be used primarily for remote microwave maintenance. We have numerous microwave sites located throughout Western Colorado. All of these sites will be maintained by my microwave crew which is presently located at 2524 North Foresight Avenue. The helicopter will normally be used on a daily basis and operate between the hours of 0700 and 1800. We presently are operating with one helicopter but anticipate using a second ship in the very near future. Our policy is to fly within the above specified hours, however, serious outages could modify this plan. Any night flying would be very minimal and practically non-existent. We have two requests to submit for your consideration.

- #1. We request permission to begin using 2524 North Foresight Avenue as a helipad as soon as possible. The helicopter would normally come to this location from the airport and pick up our technicians every morning. They would usually leave immediately for the distant sites. It would then return the technicians in the afternoon and depart for the airport.
- #2. We request permission to begin operation as a heliport on approximately July 1, 1985. We would use our existing building as a hangar and maintenance area for the helicopter. We would fuel the helicopter from our service truck which would obtain fuel from an underground tank at the same location. This operation would be co-located with our present automotive operations department. They are presently housing, maintaining, and providing fuel for numerous cars, trucks, and units of heavy equipment.

Thank you for your consideration on our request. We are trying this new concept in an effort to provide quicker response to trouble conditions with the net result of better service to all of our customers on the entire Western Slope. If there are any additional questions I can be reached on 244-4050.

Sincerely,

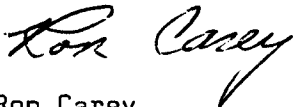

Ron Carey  
Manager - Network Switched Services

RNC:slt



June 4, 1985

TO: Grand Junction Planning Commission  
City Planning Department

SUBJECT: Amended Proposal For Mountain Bell Heliport At Foresight Circle

In response to questions and concerns brought out during our informal hearing on May 28th, we respectfully submit this revised report for your consideration. Also addressed are several issues raised during a subsequent meeting the following morning with the City Planning Department.

I have included in this report, a good deal of reference material. It was done for two reasons: To demonstrate our attitude and intentions towards our proposal, and as a basic reference in considering future heliport applications.

I would like to make clear that the material contained here is targeted for LIGHT TURBINE HELICOPTERS only. Noise signatures, route selections, and minimum altitudes will all be affected by size and type aircraft. It serves here as evidence of a great deal of thoughtful planning that has gone into our proposal for the particular type helicopter we will be using.

Our intent is to be a good corporate neighbor. Concerns of other Foresight Park tenants and surrounding residential areas have and will continue to be concerns of ours as well.

Specific approach and departure paths, minimum altitudes, flight avoidance areas, and any other restrictions necessary to keep noise to a minimum will be strictly enforced. We request that appropriate measures be taken to insure that other users, current and potential, follow whatever guidelines are established for helicopter operations at Foresight Park.

Our original application, submitted by Mr. Ron Carey, is only supplemented by this report. The information contained in his letter stands as correct, except that we expect the second helicopter now to come on line in mid July. To address and summarize questions and concerns brought up since that letter we present the following report.

Foresight Park was chosen for several reasons. Mountain Bell has appropriate facilities currently in place there, and the area has been approved and used for helicopter activity already. The physical location of Foresight, the types of businesses located there, its available approach and departure routes, its overall safety aspects, also affected our choice.

The use of Foresight over Walker Field is an expedience, economic, convenience, and transportation problem solving issue for us. We are, in fact, currently operating off the airport. The technicians primarily utilizing the helicopter are located at Foresight Park. Response time to equipment malfunctions and outages, because of the time and distance factor, in itself dictates that the technicians and helicopter colocate at the same facility.

As it now exists, we are forced to supplement helicopter availability with automobile transportation. The added expense, time, and safety factor defeats our purpose. Our intent is to consolidate personnel and equipment as a cost and time saving measure. Flight planning, scheduling, total man hours available, availability and expedience in executive use, airport fuel costs, hangar rent, office space, liability and security concerns, adequate maintenance facilities, and associated additional expenses, also had to be considered.

Our relocating to Foresight will have no adverse financial effects on Walker Field Airport. Revenues there are generated by air carriers utilizing the runways, ramp, and terminal area in the form of airport use taxes, fuel flow taxes, landing fees, etc. We do not use those facilities and are therefore not charged for them.

Hangar space is currently being rented from Monarch Aviation. Jet fuel is being purchased from a fuel distributor in town. Maintenance facilities are nonexistent. There is no water, no compressed air, and no heat or ventilation to the hangar. In addition, we are sharing space with another helicopter operator. When the second aircraft comes on line, we will be out of hangar space for it.

We have attacked this issue from every conceivable angle and the bottom line is that locating at Walker Field creates many more problems for us than it solves.

We are currently using Foresight Park as a helipad, on a temporary basis to help alleviate the time and transportation problem, but we have not solved the expedience issue, we create twice the traffic we would as a heliport, and we are faced with an additional cost of two round trip ferry flights per day at approximately a cost of \$1200 per week for the two aircraft.

Noise considerations are, appropriately, of major concern. The flight paths, as originally proposed, can easily be amended to address that problem. In reality, sound levels of small and medium size helicopters, flying as low as 200 feet, are comparable to truck engines starting 20 feet away. It is the percieved noise and the different noise a helicopter makes that is at the root of the problem. Our solution to that problem has been detailed in pages that follow.

Our amended flight corridors will be directed towards the Industrial Area to the southwest of our facility. We will restrict our altitude to not less than 500 feet above ground level while outside the boundaries of Foresight Park, and will use fast rates of descent when landing to avoid the blade slap boundaries of the aircraft.

We estimate there will be an average of 25 landings and takeoffs per month per aircraft, with each event lasting approximately 8 minutes (3 minutes to start the aircraft and takeoff, 2 minutes for the approach and landing, and 3 minutes for shutdown).

If repeated landings and takeoffs are necessary in a given day, we are willing to use the present helipad area which is located at the parking lot entrance of our facility to minimize the amount of noise reaching across the street.

Further procedures and techniques are referred to in Section V. They are not listed or discussed here to avoid repetition, but have all been analyzed and adopted where appropriate for our use at Foresight.

At this point, the Federal Aviation Administration is still reviewing our application to them. Initial contact, however, has revealed that their primary concern is how we will affect air traffic at Walker Field. A letter of agreement with the FAA and Mountain Bell will solve any potential conflicts and will be on file prior to our operating as a heliport. We see and anticipate no problems with those requirements.

If you have any further questions, or would like me to expand on any of the areas presented here, I can be reached at the number shown below, or through Ron Carey at 244-4050.

Thank you for your time and consideration.

Respectfully Submitted,

*Mike Fergione*

Mike Fergione  
Base Chief Pilot  
Mountain Bell Telephone

244-4018

June 21, 1985

RECEIVED GRAND JUNCTION  
PLANNING DEPARTMENT

JUN 25 1985

Grand Junction Planning Department  
559 White Avenue Room 60  
Grand Junction, CO 81501-2643

ATTN: Planning Commission

Gentlemen & Ladies,

I am sending this as a follow-up to our workshop on Tuesday evening, June 11, to address the issue of helicopter traffic in and around Grand Junction. I would like to keep the subject of Foresight Circle separate from my involvement in what I am going to discuss here. In this letter, I am approaching you in a different capacity, so to speak. The reasons for that will become apparent as you read on.

As far as I know, what I am going to suggest has never been tried before, but I can see no reason why it will not work. If you, as a City Planning Department, wish to implement certain rules and regulations concerning helicopter activity within the city limits in the interest of public safety, I for one, wish to highly encourage you to do so.

It would seem that a small, 5 - 10 page informational brochure targeted specifically for helicopter operators, whether they are just passing through or are based here, would not be all that expensive to produce. They could be distributed via a display in places like Monarch Aviation, through the FAA, and by direct mailings to those operators who are known to regularly or occasionally fly in and out of Grand Junction. Within that brochure, I would like to reserve space for our purposes at Foresight, and incorporate the sample approach sheet we looked at during our workshop.

What else to include:

1. Helicopter Association International publishes a tremendous amount of material in the form of a "Fly Neighborly Program". Pertinent portions could be adopted for your use.
2. A "tear out and mail in" card for those pilots wishing to critique the program with space for our own information such as type aircraft, duration of stay, type flying that aircraft is involved in, and it's impact on the noise issue.
3. You should meet with Walker Field Control Tower personnel to see if they can advise pilots to obtain a copy of the rules upon landing when they contact tower for approach instructions. Your contact there is Raymond M. Long, Air Traffic Manager, at 243-3745.

Another contact for advice is Ed Marvin, FAA Station Chief, also at Walker Field. He can be reached at 243-5233. As I understand it, he will be on vacation until the week of July 1st. There are Accident

June 21, 1985

Grand Junction Planning Department  
Helicopter Activity

Page 2

Prevention Counselors appointed by the FAA within the Grand Junction area who could be used to promote the program during their regular Accident Prevention Seminars. It would seem logical for airplane pilots to be aware of helicopter procedures much the same way as automobile drivers do for motorcycles. Accident Prevention Counselors, by the way, have no regulatory capacities. They are volunteer advisors and can only suggest compliance.

It is at this point I wish to introduce myself as other than a petitioner for a heliport. I am one of those counselors, and for obvious reasons, must insure that we avoid any potential conflicts of interest.

It would be foolish not to use the momentum of the last 3 weeks to pursue the issues discussed in the film we saw. If Foresight can be used as a stepping stone, so much the better. For now, however, I would like to pursue things in terms of helicopter traffic in general.

Your cautiousness and interest in public safety is to be encouraged. I think you are off and running in the right direction. I offer you whatever expertise I can share to help draft procedures to include helicopters in the future of Grand Junction.

I will not be back from Ft. Worth until the first week of July. Upon my return I will contact Bob Goldin to see if we can't follow up on what I've discussed here.

My thanks for your interest, and I hope I can be of some help in this matter.

Sincerely,

*Mike Fergione*

Mike Fergione  
Accident Prevention Counselor  
Grand Junction, Colorado



Oct. 25  
1985

Bob Galdin  
Senior City Planner

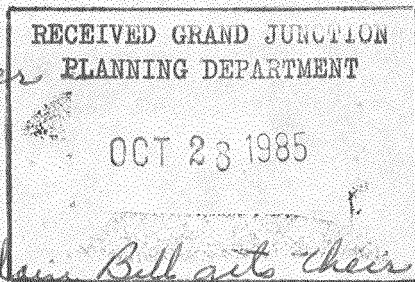

Dear Mr. Galdin:

In the event Mountain Bell gets their permanent helipad there are a couple of things we as neighbors across the street on 3<sup>rd</sup> Rd request.

A high solid fence either wood or block to help buffer the noise level, also we would like some evergreen trees on the north side of the fence. These things will help make their facility more compatible with our neighborhood. Its evident Mountain Bell could care less about their neighbors as I have tried three years to get them to do some landscaping.

We would appreciate any help you can give us on the above requests.

Sincerely  
Del & Edna Weber  
Herb & Judy High