

# Table of Contents

File 1990-0027

Name Taco Bell - C-1 & RSF-8 to PB

	<b>S c a n n e d</b>	<p>A few items are denoted with an asterisk (*), which means they are to be scanned for permanent record on the in some instances, not all entries designated to be scanned by the department are present in the file. There are also documents specific to certain files, not found on the standard list. For this reason, a checklist has been provided.</p> <p>Remaining items, (not selected for scanning), will be marked present on the checklist. This index can serve as a quick guide for the contents of each file.</p> <p>Files denoted with (**) are to be located using the ISYS Query System. Planning Clearance will need to be typed in full, as well as other entries such as Ordinances, Resolutions, Board of Appeals, and etc.</p>			
X	X	<b>Table of Contents</b>			
		Review Sheet Summary			
		Application Form			
		Review Sheets			
X		Receipts for fees paid for anything			
		<b>*Submittal checklist</b>			
		<b>*General project report</b>			
		Reduced copy of final plans or drawings			
		Reduction of assessor's map.			
		Evidence of title, deeds, easements			
X	X	<b>*Mailing list to adjacent property owners</b>			
		Public notice cards			
		Record of certified mail			
X		Legal description			
		Appraisal of raw land			
		Reduction of any maps - final copy			
		<b>*Final reports for drainage and soils (geotechnical reports)</b>			
		Other bound or non-bound reports			
		Traffic studies			
X	X	<b>*Petitioner's response to comments</b>			
X	X	<b>*Staff Reports</b>			
		<b>*Planning Commission staff report and exhibits</b>			
		<b>*City Council staff report and exhibits</b>			
X	X	<b>*Summary sheet of final conditions</b>			
		<b>*Letters and correspondence dated after the date of final approval (pertaining to change in conditions or expiration date)</b>			
<b><u>DOCUMENTS SPECIFIC TO THIS DEVELOPMENT FILE:</u></b>					
X	X	Action Sheet - Approved 5/8/91	X	X	Project Narrative
X	X	Review Sheet Summary	X		Sign Diagrams
X		Review Sheets	X		Request for Treasurer's Certificate of Taxes Due - 5/21/90
X		Development Application - 5/23/90	X		Commitment for Title Insurance Company - 5/15/90
X	X	Fence Permit - 6/3/91	X	X	Ordinance No. 2483 - **
X	X	City Council Minutes - ** - 7/18/90, 8/1/90, 8/15/90, 10/17/90	X		Notice of Public Hearing - 7/10/83
X	X	Minor Change fee - \$50.00	X		Daily Sentinel Article - "Taco Bell Rezoning OK'd"
X		Certificate of Occupancy - 6/3/96	X	X	Floor Plan
X	X	Development Summary - 7/10/90	X	X	Exterior Elevations
X		City Council Workshop Agenda- 7/16/90, 10/15/90	X	X	Grading and Drainage Plan - Parking Lot and Bldg site-6/8/90, 6/13/90, 6/30/90
X		Final City Council Agenda - 7/18/90, 8/1/90	X	X	Revised Landscape Plan - Taco Bell Rebuild Plan - 6/8/90, 6/12/90, 7/4/90, 8/29/90
X		Preliminary City Council Agenda - 10/17/90	X		Lighting Analysis
X		Public Notice Posting - 7/20/90	X	X	Lighting Plan
X	X	Signed Petition regarding entrance exit to Taco Bell - 7/16/90	X		Letter from Howard Roberts and Lisa Roberts to City Council re: requesting a 14 day deadline to file an appeal on the plan to construct parking lot - 7/13/90



PROJECT NARRATIVE  
NORTH AVE.  
TACO BELL

#27 90

Original  
Do NOT Remove  
From Office

Moss Inc. proposes to rezone the property located at 845 thru 865 Glenwood Ave. from RSF-B to PB. We also propose to rezone 848 North Ave. from C-1 to PB., this property is now occupied by Taco Bell. Our proposal is to make all of this property a PB development for the new Taco Bell restaurant to be built.

We are presently in the process of purchasing the lots on Glenwood Ave. We have a contract interest in said property and are scheduled to close on or before August 1, 1990, if we obtain the rezone. Moss Inc. presently leases the property on North Ave. We have leased it for approximately 19 years. However we are also going to purchase this property and build a newer and larger restaurant in 1991.

We intend to begin building this project in June of 1991. There will be no phasing to the project. We intend to complete the project in approximately 90 days. The project will include developing the three (3) lots on Glenwood into a parking area and small park area. Our plan is to do extensive landscaping. On the North Ave property we plan to construct a new Taco Bell restaurant which will seat approximately 80 people. We will also do extensive paving and landscaping.

The area impacted by the project will be the North Ave. corridor and exit on to Glenwood Ave.

This project will allow extra parking for the Taco Bell restaurant which has been needed for quite some time. The new Taco Bell restaurant will be the newest and largest Taco Bells presently being built, which will help modernize and update the appearance of the North Ave. corridor. The project will take three (3) lots on Glenwood Ave. which are currently in dirt and unmaintained, and develop these parcels into a very attractive and landscaped parking and park area. The renovation of the existing Taco Bell will we project increase overall sales, which will increase our city tax base, which will help the public.

The North Ave. property is currently zoned commercial and has been used as such by Taco Bell for 19 years. The property to the East & West & South of Taco Bell is currently zoned commercial.

**DOOR SCHEDULE**

DOOR NO.	DOOR SIZE	DOOR TYPE				MATERIAL	DOOR FRAME	BUTTS	LOCKS				CLOSERS	THRESHOLD	DOOR STOP	DETAIL	REMARKS
		A	B	C	D				1	2	3	4					
(1)	8'-0" x 7'-0" x 1/4"																
(2)	8'-0" x 7'-0" x 1/4"																
(3)	8'-0" x 7'-0" x 1/4"																
(4)	8'-0" x 7'-0" x 1/4"																
(5)	8'-0" x 7'-0" x 1/4"																
(6)	8'-0" x 7'-0" x 1/4"																
(7)	8'-0" x 7'-0" x 1/4"																
(8)	8'-0" x 7'-0" x 1/4"																
(9)	8'-0" x 7'-0" x 1/4"																
(10)	8'-0" x 7'-0" x 1/4"																

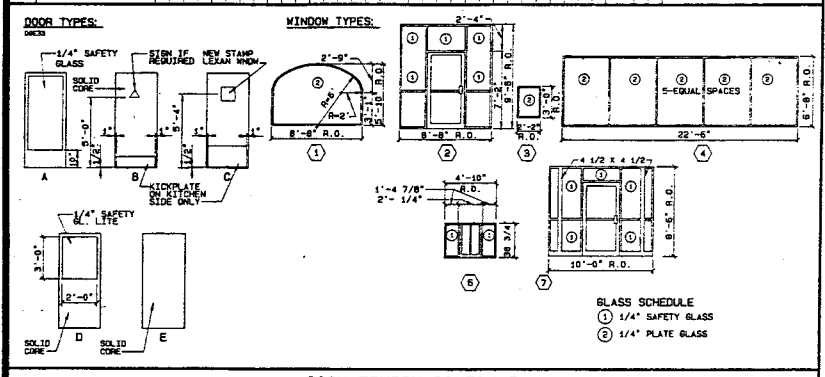

ROOM FINISH SCHEDULE										
ROOM NO.	ROOM TITLE	FLOORS	BASES	WALLS	CEIL.	DOORS	FRAMES	TRIMS	REMARKS	
100	DINING AREA	2	6 7	14	17 18 19 20 21	23	24	25 26	GYP. BD. SOFFIT & PLANTER - SEE ID-2	
101	CUSTOMER AREA	2	6 7	14	17 18 19 20 21	23	24	25 26		
102	SERVING AREA	1	5	11 12	17 18 19 20 21	23	24	25 26		
103	KITCHEN AREA	1	5	11 12	17 18 19 20 21	23	24	25 26		
104	WORK AREA	1	5	13	17 18 19 20 21	23	24	25 26		
105	COOLER	1	5						COOLER IS A PACKAGE UNIT	
106	PANTRY AREA	1	5	13	17 18 19 20 21	23	24	25 26		
107	EMPLOYEE AREA	1	5	13	17 18 19 20 21	23	24	25 26		
108	MEN'S TOILET	2	7	13	17 18 19 20 21	23	24	25 26		
109	WOMEN'S TOILET	2	7	13	17 18 19 20 21	23	24	25 26		
110	OFFICE	1	5	10	17 18 19 20 21	23	24	25 26		
111	VESTIBULE	2	6 7	14	17 18 19 20 21	23	24	25 26		
112	JANITOR'S CLOSET	2	7	10	17 18 19 20 21	23	24	25 26		

- FLOORS:**
- TL-2 QUARRY TILE, AMERICAN DEAN 9-01 CANTON RED-ABRASIVE 6" x 6" w/ GRAY GROUT. SEE FLN FOR EXTENT OF ABRASIVE TILE.
  - TL-4 SEE INTERIOR DESIGN SHT. ID-3.
  - TL-2 QUARRY TILE-COVE, AMERICAN DEAN CANTON RED 3" HIGH x 6"
  - ALUMINUM KAMMER STOREFRONT NO. 40 DARK BRONZE
  - TL-1 SEE INTERIOR DESIGN SHT. ID-3.
  - GYP. BD. PAINTED, BENJAMIN MOORE REGAL AGUARO NO. 333-915 (DW-75)
  - TL-3 CERAMIC TILE, DAL-TILE NO. D35 ALMOND 4 1/4" x 4 1/4" x 5/16" ALT; INTERNATIONAL TILE #8257-275
  - SEE INTERIOR DESIGN SHT. ID-3.
  - OPTIONAL STRIPES TL-4, TL-5, & TL-6
  - MARLITE REINFORCED FIBERGLASS PANEL P-118 NATURAL ALMOND
  - M-1 SEE INTERIOR DESIGN SHT. ID-3.
- CEILING:**
- SUSPENDED CEILING TILE, U.S. GYPSUM (100) P-120, 24" x 24" x 1/2" SHELL, FIRE-RESISTANT
  - GYP. BD. PAINTED, BENJAMIN MOORE REGAL AGUARVELT NO. 319-948 (DW-12)
  - SUSPENDED ACoustical TILE, U.S. GYPSUM 24" x 24" x 3/4" BLAZIER ACOUSTIC SG CUT, LAY-IN PANELS.
- DOORS:**
- ALUMINUM KAMMER STOREFRONT NO. 40, DARK BRONZE
  - M-3 SEE INTERIOR DESIGN SHT. ID-3
  - WOOD METAL-PAINTED, BENJAMIN MOORE REGAL AGUARO NO. 333-915 (DW-75)
  - ALUMINUM KAMMER STOREFRONT NO. 40, DARK BRONZE
  - M-3 SEE INTERIOR DESIGN SHT. ID-3
  - METAL-PAINTED, BENJAMIN MOORE REGAL AGUARO NO. 333-915 (DW-75)
- FRAMES:**
- ALUMINUM KAMMER STOREFRONT NO. 40, DARK BRONZE
  - M-3 SEE INTERIOR DESIGN SHT. ID-3
  - METAL-PAINTED, BENJAMIN MOORE REGAL AGUARO NO. 333-915 (DW-75)
- TRIM & SHELVING:**
- SHELVING PAINTED, BENJAMIN MOORE IMPROVED HIGH GLOSS NO. 303-915 (DW-75)
  - 28 LB. PLASTIC LAMINATE, INTERIOR DESIGN #319-948 (DW-12) CHOPPER SHELF
- NOTES:**
- ALL CERAMIC WALL TILE SHALL HAVE WHITE GROUT.
  - SUSPENSION SYSTEM FOR LAY-IN TILE TO BE CORNER 200 SERIES FIRE RATED EXPOSED GRID WITH WHITE ALUMINUM CAP.
  - ALL AMERICAN DEAN CANTON RED TILE TO HAVE GREY GROUT.
  - ON TACO BELL SUPPLIED DECOR ITEMS, THE S.C. IS TO REFER TO THE 10 SHEETS FOR TILE BASE TO BE FURNISHED AND INSTALLED BY NGR.
  - TEXTURED PAINT IS TO BE 1/2 GALLON OF PAINT MIXED WITH 12 POUNDS OF U.S.G. ALL PURPOSE COMPOUND.

DIMENSIONS SHOWN ARE NOMINAL TO THE FACE OF GYP. BD. AND/OR EXT. PLYWOOD SHEATHING.

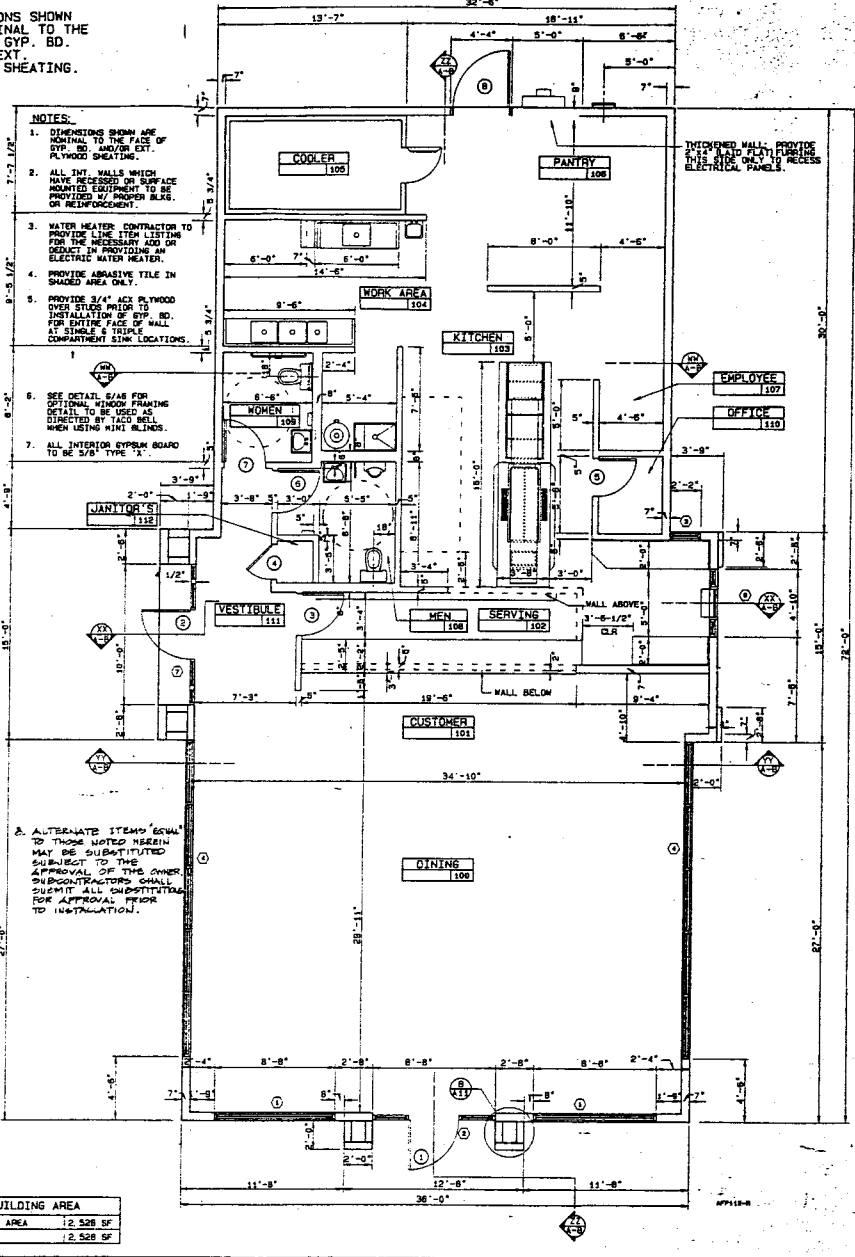

**FLOOR PLAN**

**FLOOR PLAN SCHEDULES**

REVISIONS

NO.	DATE	BY	REVISION

DESIGNED BY: M-S-D-G  
 DRAWN BY: S. FRM. REV.  
 DATE: 9-1-88  
 JOB NUMBER: 9-1-88  
 SCALE: 1/4"=1'-0"

**A3**

**DIRECTIONAL SIGNS**

**16" x 36 7/8" DF C-P Anchor Bolt Mounted Directional Sign**

Double face sign with flat pan polycarbonate faces. Choice of seven standard copy selections plus arrow and Taco Bell logo. Can be ordered in any combination.

Sign box is of extruded aluminum and is constructed to meet 35 PSF wind load. Electrical meets standards of National Electric Code and Underwriters Laboratories, Inc. Sign bears U.L. label.

Sign is supplied with a 3" x 3" square steel tube with base plate.

Foundation supplied by General Contractor. Four 1/2" anchor bolts required.

**Electrical Specifications:**

- Lamps: (2) 36T12 H/O C.W.
- Ballast: (1) Jefferson 256-1311
- Conn. Load: 1.17 AMPS
- Circuits: (1) 15 AMP

**Service sign by:** Sliding face  
**Lifting Weight:** 28 lbs.

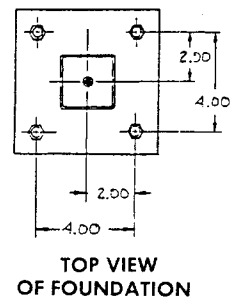
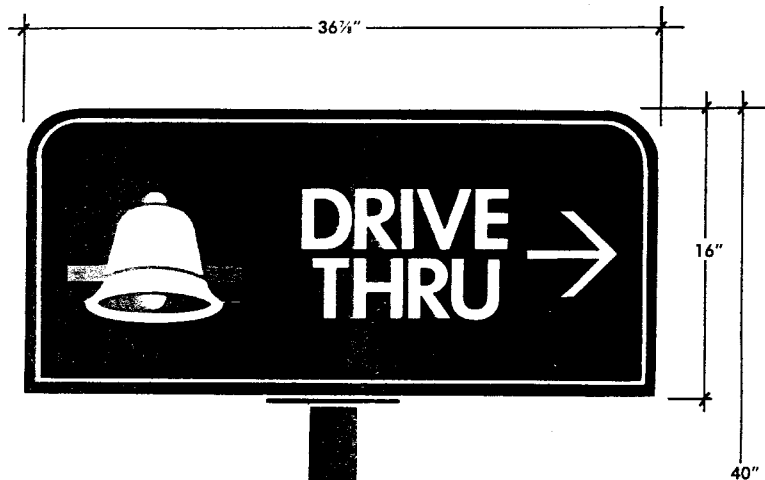

Plasti-Line, Inc.

Z-10

Original Do NOT Remove From Office

# 25 90

**BUILDING MOUNTED SIGNS**

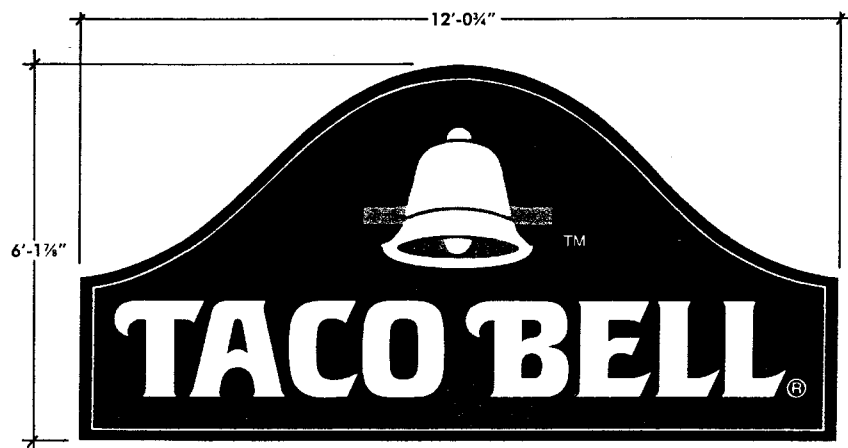

**B-1 72 Square Feet  
6'-1 1/8" x 12'-0 3/4" Mission Building Sign**

Single face sign with one-piece, prescreened face of polycarbonate, pan embossed. Sign box is of extruded aluminum and designed to meet 30 PSF wind load. Electrical meets standards of National Electric Code and Underwriters Laboratories, Inc. Sign bears U.L. label.

**Electrical Specifications:**

- Lamps: F36T12 H/O C.W. (1)  
F48T12 H/O C.W. (2)  
F64T12 H/O C.W. (1)  
F72T12 H/O C.W. (6)
- Ballast: Jefferson 262-272 (1)  
Jefferson 262-472 (2)  
Jefferson 262-001 (6)
- Conn. Load: 7.5 AMPS
- Circuits: 15 AMP (1)

**Service sign by:** Remove Face  
**Lifting Weight:** 550 lbs.

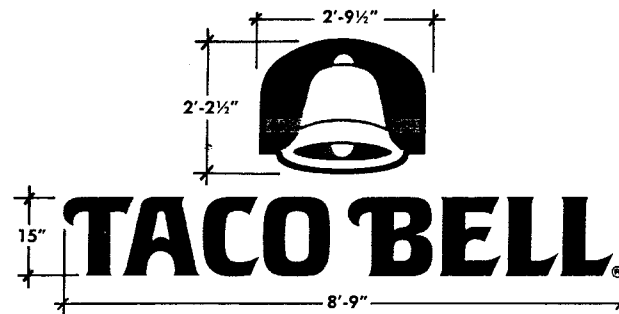

**B-2 17 Square Feet  
2' x 3' Mini Bell with 15" Neonized Letters**

**Mini Bell**

2' x 3' Mini Bell logo is a single face sign with one-piece, prescreened face of polycarbonate, pan embossed. Sign box is extruded aluminum with Kydex back and designed to meet 30 PSF wind load. Electrical meets standards of National Electrical Code and bears U.L. label.

**Electrical Specifications:**

- Lamps: U6-36T12 H/O C.W. (2)  
U6-24T12 H/O C.W. (2)  
F24T12 H/O C.W. (1)
- Ballast: Jefferson 262-448 (1)  
Jefferson 262-001 (2)
- Conn. Load: 2.0 AMPS
- Circuits: 15 AMP (1)

**Service sign by:** 42 lbs.  
**Lifting Weight:** Remove Face

**Letters**

Individually mounted neonized embossed letters, internally illuminated with remote transformer boxes behind wall. Individual letters are 15" high and the entire unit covers 8'-9" in length.

**Electrical Specifications:**

- Transformer: France 7560-P (2)
- Lamps: 12 MM Neon Tubing
- Voltage: 120 Volts
- Total Conn. Load: 4.0 AMPS
- Circuit: 20 AMP (1)

**Service sign by:** Remove faces  
**Lifting Weight:** TACO- 80 lbs., BELL- 80 lbs.

Original  
Do NOT Remove  
From Office  
#27 90

**GROUND MOUNTED LOGO SIGNS**

**Ground Mounted Logo Signs**

Double face sign with one-piece, prescreened logo faces of polycarbonate. Logo faces are pan embossed with white border. Appendage faces are one-piece, prescreened polycarbonate and are embossed with white border. Optional copy reading: DRIVE THRU or WELCOME.

Sign box is extruded aluminum. Electrical meets standards of National Electric Code and bears U.L. label.

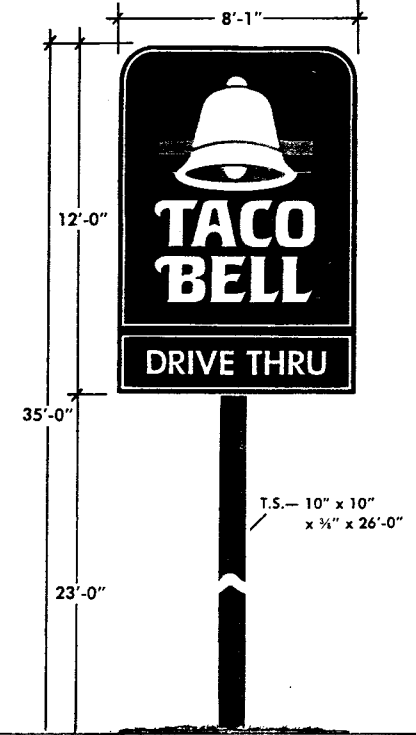
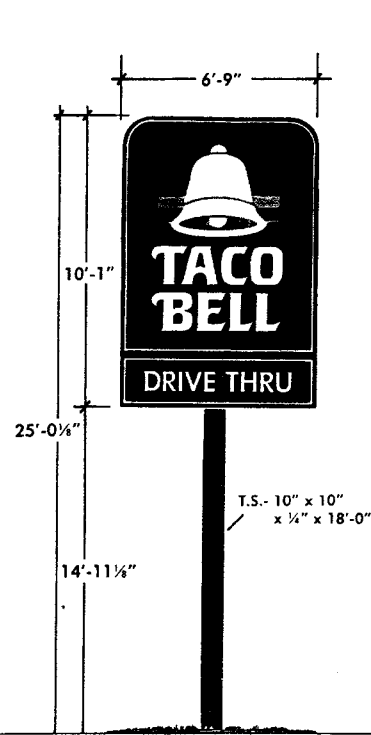
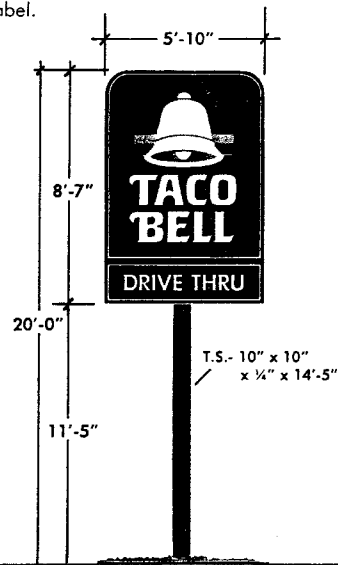
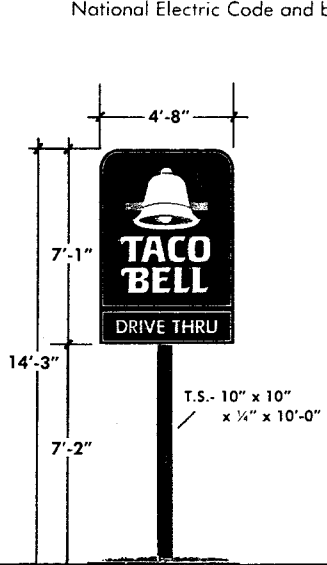

**P1 32 Square Feet**  
7'-1" x 4'-8" DF C-P Logo Sign  
at 15' OAH

**Electrical Specifications:**  
Lamps: 84T12 H/O C.W. (4)  
Ballast: Jefferson 262-484-100  
Conn. Load: 3.85 AMPS  
Circuits: 15 AMPS (1)  
**Service sign by:** Hinged Face  
**Lifting Weight:** 230 lbs.  
**Maximum Design**  
**Wind Load:** 30 PSF

**P2 50 Square Feet**  
8'-7" x 5'-10" DF C-P Logo Sign  
at 20' OAH

**Electrical Specifications:**  
Lamps: F96T12 H/O C.W. (6)  
Ballast: Jefferson 262-002  
Conn. Load: 5.4 AMPS  
Circuits: 15 AMPS (1)  
**Service sign by:** Hinged Face  
**Lifting Weight:** 290 lbs.  
**Maximum Design**  
**Wind Load:** 35 PSF

**P3 69 Square Feet**  
10'-1" x 6'-9" DF C-P Logo Sign  
at 25' OAH

**Electrical Specifications:**  
Lamps: 117T12 H/O C.W. (6)  
Ballast: Jefferson 262-496-100 (2)  
Conn. Load: 7.7 AMPS  
Circuits: 15 AMPS (1)  
**Service sign by:** Hinged Face  
**Lifting Weight:** 490 lbs.  
**Maximum Design**  
**Wind Load:** 30 PSF

**P4 97 Square Feet**  
12'-0" x 8'-1" DF C-P Logo Sign  
at 35' OAH

**Electrical Specifications:**  
Lamps: F60T12 H/O C.W. (2)  
F64T12 H/O C.W. (2)  
F84T12 H/O C.W. (8)  
Ballast: Jefferson 262-464 (2)  
Jefferson 262-484 (2)  
Jefferson 262-002 (8)  
Conn. Load: 13.1 AMPS  
Circuits: 20 AMP (1)  
**Service sign by:** Hinged Face  
**Lifting Weight:** 1205 lbs.  
**Maximum Design**  
**Wind Load:** 30 PSF

Original Do NOT Remove From Office 127 90

## MONUMENT SIGNS

### M-5 20 Square Feet 3'-9" x 5'-3" DF T-P Monument Sign

Double face sign with one-piece, prescreened logo faces of polycarbonate. Logo faces are pan embossed with white border. Appendage faces are one-piece, prescreened polycarbonate and are embossed with white border. Optional copy reading: DRIVE THRU or WELCOME.

Sign box is extruded aluminum and constructed to meet 35 PSF wind load. Electrical meets standards of National Electric Code and bears U.L. label. Support columns are 3" x 2" tube steel.

Textured base supplied by General Contractor.

#### Electrical Specifications:

Lamps:	F60T12 H/O C.W. (4)
Ballast:	Jefferson 262-460 (1) Jefferson 262-001 (2)
Conn. Load:	2.3 AMPS @ 120 V., 60 Hz
Circuits:	15 AMP (1)
Service sign by:	Hinged Face
Lifting Weight:	231 lbs.



### M-1 32 Square Feet 7'-2" x 4'-7½" DF C-P Monument Sign

Double face sign with one-piece, prescreened logo faces of polycarbonate. Logo faces are pan embossed with white border. Appendage faces are one-piece, prescreened polycarbonate and are embossed with white border. Optional copy reading: DRIVE THRU or WELCOME.

Sign box is extruded aluminum and constructed to meet 30 PSF wind load. Electrical meets standards of National Electric Code and bears U.L. label. Support column is 10" x 10" square steel tube.

Textured base is supplied by General Contractor.

#### Electrical Specifications:

Lamps:	84T12 H/O C.W. (4)
Ballast:	Jefferson 262-484-100
Conn. Load:	3.85 AMPS
Circuits:	(1) 15 AMP
Service sign by:	Hinged face
Lifting Weight:	377 lbs.



#87 90

Original  
Do NOT Remove  
From Office



# FRAME FOR SIDEWALK DRAIN TROUGH

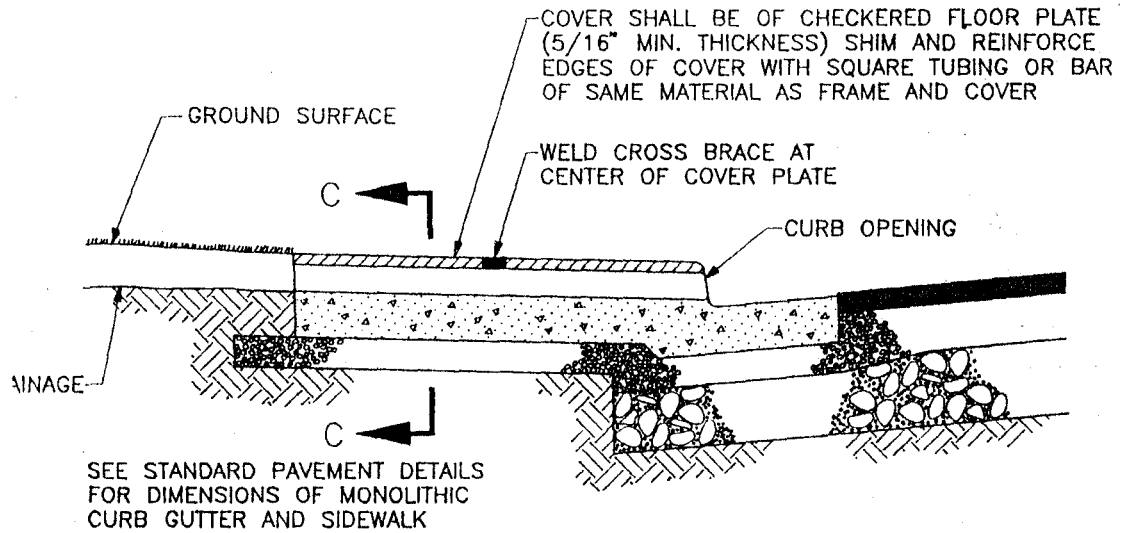

NOTE: BOTH FRAME AND COVER SHALL BE FABRICATED OF SAME MATERIAL (STEEL OR ALUMINUM) ALL STEEL SURFACES SHALL BE GALVANIZED

# DRAIN TROUGH FOR SIDEWALK CROSSING

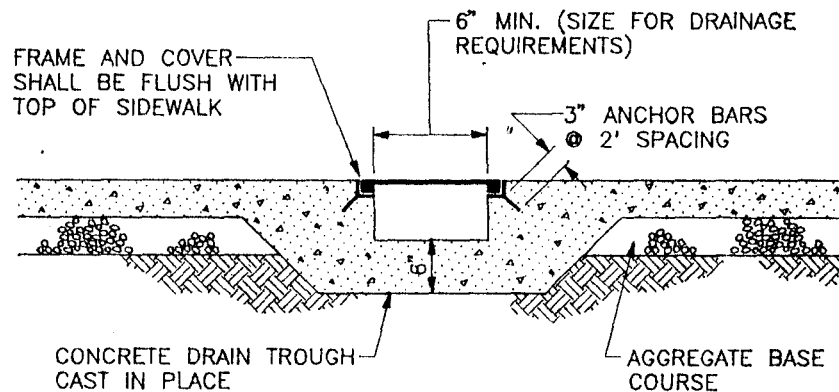

## SECTION C-C

PERCENT BY WEIGHT PASSING SQUARE MESH SIEVES			
SIEVE SIZE	PIPE BEDDING & HAUNCHING MATERIAL (CRUSHED ROCK) TYPE A	GRANULAR STABILIZATION MATERIAL (SCREENED OR CRUSHED ROCK) TYPE B	PIT RUN AGGREGATE (TO BE USED WHERE SPECIFIED OR DIRECTED BY THE ENGINEER)
8 INCH	----	----	100
2 INCH	----	100	----
1 INCH	100	----	----
0. 200	15 MAX	15 MAX	20 MAX

NOMINAL SIZE OF PIPE	MAXIMUM TRENCH WIDTH AT TOP OF PIPE	MINIMUM TRENCH WIDTH AT PIPE SPRINGLINE
LESS THAN 18"	PIPE O.D. + 18"	PIPE O.D. + 12"
18" THRU 36"	PIPE O.D. + 24"	PIPE O.D. + 18"

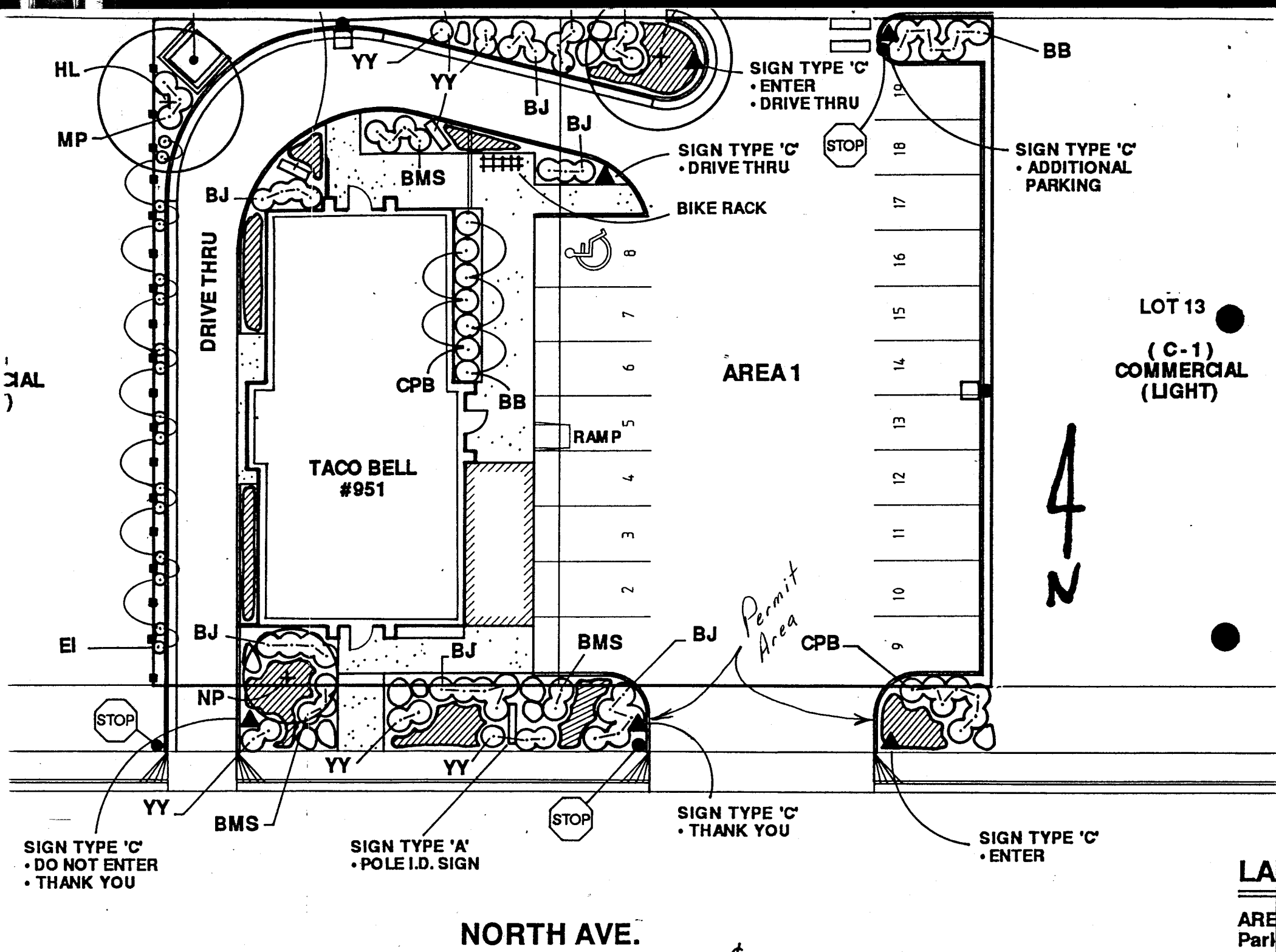

LA  
ARE  
Park  
Land  
Dist

# GLENWOOD AVE.

Permit Area

GR

NO LEFT TURN

STOP

SIGN TYPE 'C'  
TACO BELL  
PARKING

EMPLOYEE PARKING (6 SPACES)

AREA 2

SIGN TYPE 'C'  
ADDITIONAL  
PARKING

STOP

STOP

PEDESTRIAN  
CROSS WALK

HL  
ALLEY

SI  
• E

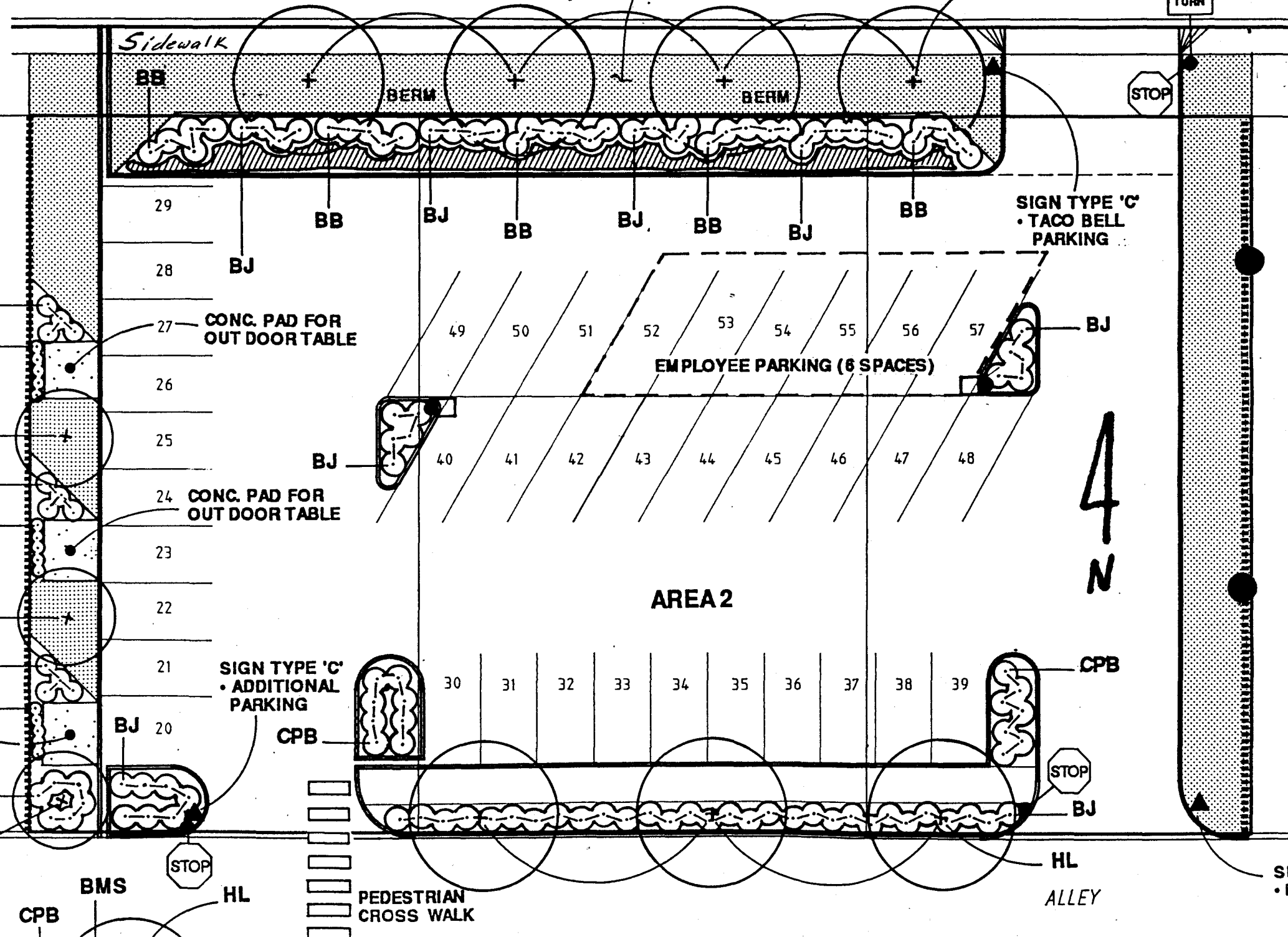

DO NOT Remove from Office

SIGNAGE

Z-A

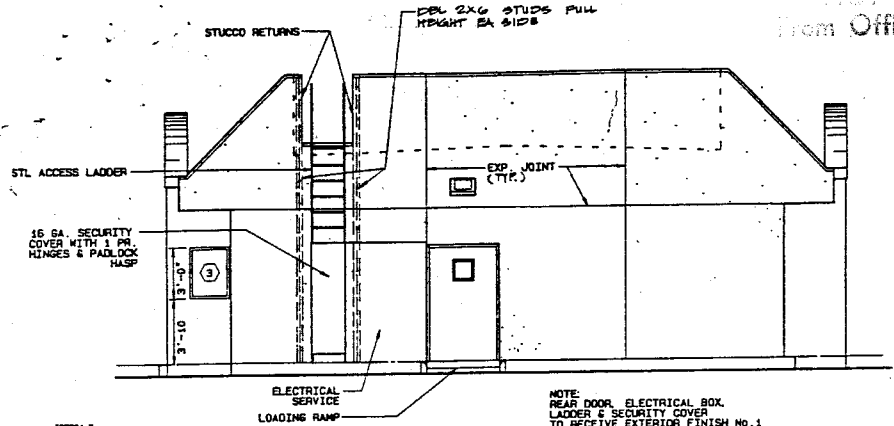

REAR ELEVATION

SCALE: 1/4" = 1'-0"

SIGN & ROUGH-IN CANS FOR EACH SIGN WILL BE FURNISHED DIRECTLY TO THE CONTRACTOR & IS TO BE INSTALLED PRIOR TO INSTALLATION OF STUCCO  
 6" C. TO PROJECT STUCCO 3/4" FROM FACE OF PREFAB TOWER (TYP.)

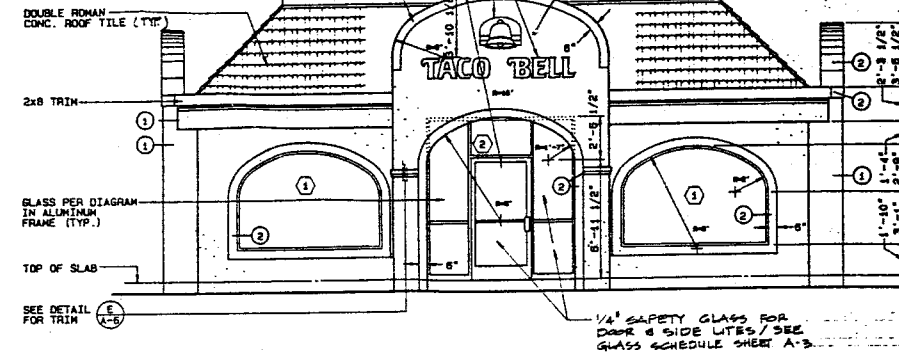

FRONT ELEVATION

SURFACE	FINISH
STUCCO	①
PROJECTED SURROUNDS, PROJECTED BAND	②
FASCIA, FASCIA FLASHING, STUCCO SOFFIT	②
PLANTER	②
PARAPET FLASHING	②
CLEARESTORY SIDING & FLASHING	②
LIGHT POLES	②
EXPOSED UTILITY PIPES & CONDUIT	②
METAL DOORS & FRAMES	②
COOLER FLASHING	②
SHEET METAL FASCIA TRIM	②
GAS METER & ELECTRICAL SERVICE	②

- FINISHES:
- BENJAMIN MOORE HOORWARD EXTERIOR LATEX No. 103-1072 (CB-18)
  - BENJAMIN MOORE HOORWARD EXTERIOR LATEX No. 103-1128 (CB-16)
- STUCCO NOTES:
- COLD JOINTS WILL NOT BE ACCEPTABLE UNDER ANY CIRCUMSTANCES.
  - MESH AS SPECIFIED SHALL NOT OVERLAP & CONTROL JOINTS.
  - MESH OVERLAPS SHALL NOT COINCIDE WITH PLYWOOD JOINTS.
  - MESH WITH GRID EXCEEDING 2"x2" WILL BE REJECTED.
  - USE OF FASTENERS OTHER THAN GALVANIZED NAILS WILL NOT BE ACCEPTED.
  - SCARIFICATION AS SPECIFIED SHALL ALWAYS BE IN THE HORIZONTAL DIRECTION.
  - INTERIOR DRYWALL WILL ALWAYS BE INSTALLED PRIOR TO APPLICATION OF STUCCO.

NOTE: EXP. JOINTS TO BE CONT. ON WALL, SOFFIT & FACE OF FASCIA (TYP.)

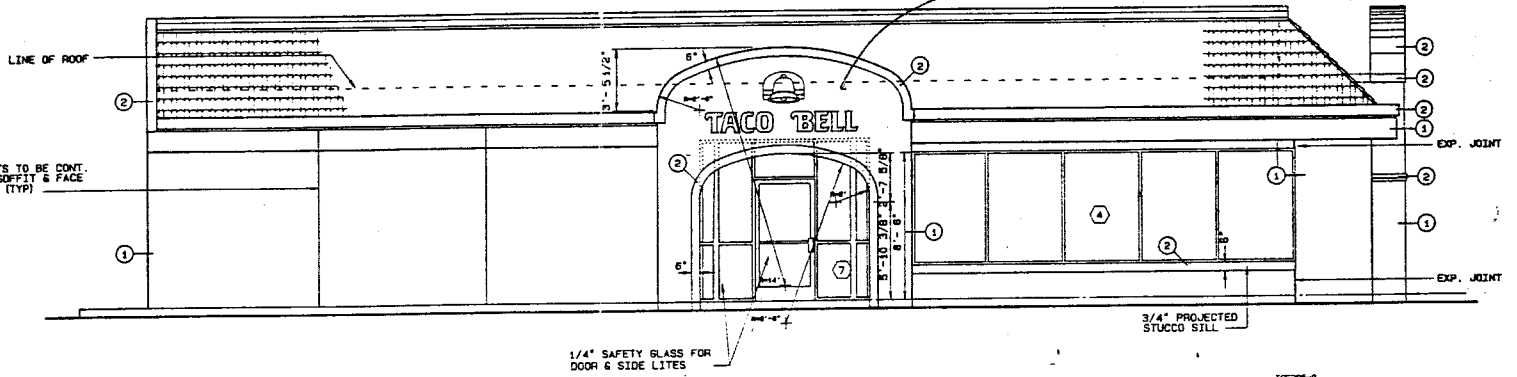

LEFT SIDE ELEVATION

SIGNAGE 15#

EXTERIOR FINISH SCHEDULE

- CAULK ALL WALL AND ROOF PENETRATIONS.
- APPLY ONE COAT OF WATERPROOFING TO ALL HORIZONTAL STUCCO SURFACES ONLY.
- SEE SPECIFICATIONS FOR NAILING PATTERN AND REQUIREMENTS FOR 1/2" EXTERIOR GRADE PLYWOOD.
- ALTERNATE MATERIALS ALUMINUM FRAMING: VISTA WALL (214) 263-2620 U.S. ALUMINUM - PAUL ADLER (213) 268-4230
- CAULK ALL WINDOW & DOOR FRAMES AT HEAD, SILL & JAMB (EXTERIOR & INTERIOR).
- STUCCO FINISH TO BE "MEDIUM DASH" AS SPECIFIED BY THE STUCCO MANUFACTURERS ASSOCIATION.
- ARCH RADIUS DIMENSIONS ARE GIVEN FOR GENERAL CONTRACTORS REFERENCE ONLY.
- DOUBLE ROMAN CONCRETE ROOF TILE TO BE ORDERED FROM WESTLIE, LITTLETON, CO. ATTN: BOB REDERS (303) 797-0630 - ICBO REPORT NUMBER FOR ROOF TILE IS 3984.
- WOOD TRIM ON FASCIA TO BE "C SELECT" (IMP-CHOICE) S4S.
- DEEP RED CLAY MISSION TILE MAY BE USED WHEN APPROVED BY TACO BELL. INSTALLATION OF CUT TILE AT TOP AND CORNER RIDGES SHALL BE WITH MORTAR AND NOT WIRE HOOKS.

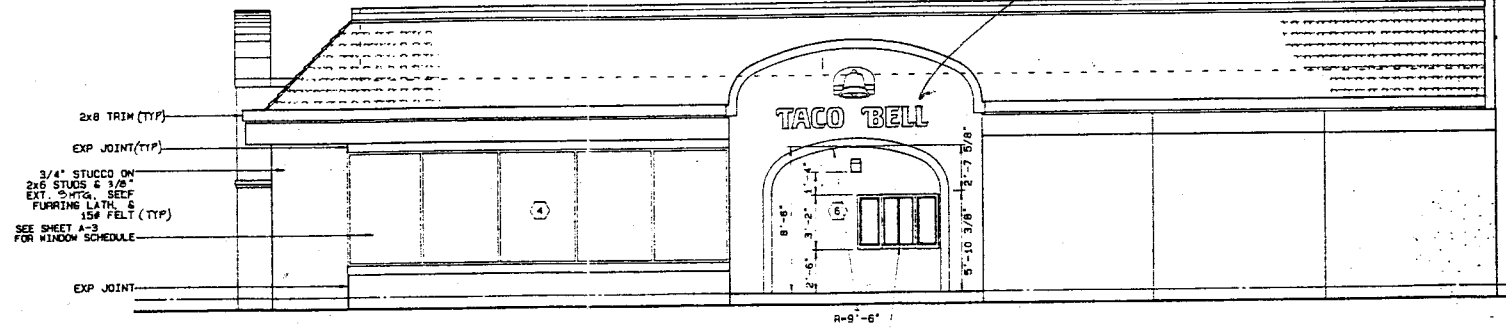

RIGHT SIDE ELEVATION

SIGNAGE 15#

# STATE OF COLORADO

## DEPARTMENT OF HIGHWAYS

222 South Sixth Street, P.O. Box 2107  
Grand Junction, Colorado 81502-2107  
(303) 248-7208



August 2, 1990

Michael Saelens  
Real Estate and Development  
Moss Inc.  
Sierra Bells Inc.  
715 Horizon Drive, Suite 380  
Grand Junction, CO 81506

Dear Mr. Saelens:

This letter is to acknowledge receipt of your letter dated July 23, 1990, requesting permission to landscape within State Highway right of way.

At this time, the City of Grand Junction has jurisdiction over any right of way behind the curb line of State Highway 6 (North Avenue) with the exception of advertising signs.

The large type "A" sign of your revised landscape plan can not be placed on right of way under current policy and regulation. The smaller type "C" signs can be installed providing there is no advertising message included on them and they do not restrict sight distance to less than 500 feet in either direction from either access.

If you have further questions, please contact this office. A copy of the State Rules and Regulations for Outdoor Advertising is enclosed.

Yours truly,

R. P. MOSTON  
DISTRICT ENGINEER

By

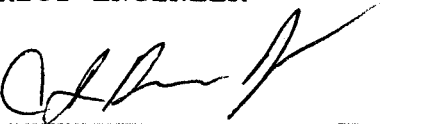
  
C. I. Dunn, Jr.  
District ROW Engineer

EKD:rb  
Enc.  
cc: Sanburg  
Dry

MEMORANDUM

*mb ✓*  
*Klu ✓*

To: Greg Trainor  
From: Tim Woodmansee *Tim*  
Date: October 11, 1990  
Subj: Request for Revocable Permit

John and Judy Moss, owners of the Taco Bell on North Avenue, are requesting a Revocable Permit to allow the installation of signage and landscape improvements in the unused right-of-way for North Avenue and Glenwood Avenue.

All landscape improvements and sign locations were presented and recommended for approval by staff during the recent rezoning process. The Revocable Permit, therefore, will formally allow use of the right-of-way as contemplated during the rezoning procedures.

Since the request involves two separate roadways, I am recommending the issuance of two separate permits so that revocation of one will not affect the status of the other.

This item is to be included on the October 17 Council agenda.

cc: Mark Achen  
Dan Wilson  
Don Newton  
~~Marty Currie~~  
Eileen List  
Neva Lockhart

# 27 90  
Remove  
from Office

Violet L. Owen  
177 Edlum Rd.  
Grand Junction, CO 81503  
2945-141-03-001

Central Bank  
Trustee for Roy VanZante  
P.O. Box 608  
Grand Junction, CO 81502  
2945-114-19-002

Darrell C. Maluy  
548 Glenwod Drive  
Grand Junction, CO 81503  
2945-114-19-011

BI- Mesa Investments, Inc.  
P.O. Box 216  
Clifton, CO 81520  
2945-141-03-004

Jack A. & W. Avis Brown  
825 Glenwood  
Grand Junction, CO 81502  
2945-114-19-003

Kip & Wendy Koski  
0010 Fender Lane  
Carbondale, CO 81623  
2945-114-19-012

City Market  
P.O. Box 729  
Grand Junction, CO 81502  
2945-141-03-005

Merrilyn L. & Frank W. Turman  
825 Glenwood  
Grand Junction, CO 81502  
2945-114-19-003

Newton L. Koser  
2360 S. Garfield  
Denver, CO 80210  
2945-114-19-021

BI-Mesa Investments  
P.O. Box 216  
Clifton, Co 81520  
2945-141-03-007

Russell K. & Gloria L. Parry  
835 Glenwood  
Grand Junction, CO 81502  
2945-114-19-004

Fern W. Moss  
Trustee of Moss Family Trust  
11610 Tulane  
Riverside, CA 92507  
2945-114-19-023

City Market  
P.O. Box 729  
Grand Junction, CO 81502  
2945-141-03-008

Amora L. Bley & W. Jo Cortese  
407 North 7 Street  
Grand Junction, CO 81502  
2945-114-19-005

Velva V. Carnes  
212 Country Club Park  
Grand Junction, CO 81503  
2945-114-19-017

Violet L. Owen  
C/O City Market  
P.O. Box 729  
Grand Junction, CO 81502  
2945-141-03-009

Amora L. Bley & W. Jo Cortese  
407 North 7 Street  
Grand Junction, CO 81502  
2945-114-19-006

Modern Federal Savings & Loan  
C/O Mitchell & Brian Schumaker  
P.O. Box 160  
Grand Junction, CO 81502  
2945-114-19-018

MSSW, Inc.  
P.O. Box 2797  
Grand Junction, CO 81502  
2945-141-04-022

Amora L. Bley & W. Jo Cortese  
407 North 7 Street  
Grand Junction, CO 81502  
2945-114-19-007

Mary E. & Robert Taylor  
763 Glenwood  
Grand Junction, CO 81502  
2945-114-18-001

MSSW. Inc.  
P.O. Box 2797  
Grand Junction, CO 81502  
2945-141-04-025

Patricia L. Robinson  
P.O. Box 523  
Meeker, CO 81641  
2945-114-19-008

Rankin & Co. Inc.  
1043 North Ave.  
Grand Junction, CO 81501  
2945-114-18-010

Central Bank  
Trustee For Roy VanZante  
P.O. Box 608  
Grand Junction, CO 81502  
2945-114-19-001

John P. Canning  
P.O. Box 40241  
Grand Junction, CO 81504  
2945-114-19-009

Lowell W. Laycock  
805 Bunting Ave.  
Grand Junction, CO 81501  
2945-114-17-001

Fannie R. Susman  
2015 North 5 Street  
Grand Junction, CO 81501  
2945-114-19-010

Judith K. Moran  
815 Bunting Ave.  
Grand Junction, CO 81501  
2945-114-17-002

Sieghardt & Elvaretta F. Klaus 825 Bunting Ave. Grand Junction, CO 81501 2945-114-17-003	St. Mathews Episcopal Church P.O. Box 766 Grand Junction CO 81501 2945-114-17-951	Martin A. & Carol Marilyn Wenger 1132 Cannell Ave. Grand Junction, CO 81501 2954-114-22-014
Donald B. & Geneva N. Hoisington 833 Bunting Ave. Grand Junction, CO 81501 2945-114-17-004	William J. & M. A. Ruppert 856 Glenwood Ave. Grand Junction, CO 81501 2945-114-17-012	Leonard D. & I. J. Pepper 1142 Cannell Ave. Grand Junction, CO 81501 2945-114-22-015
Dorothy Jean Robbins 1075 21 1/2 Road Rt. #2 Grand Junction, CO 81505 2945-114-17-005	Wm. J. & Marjorie A. Ruppert 856 Glenwood Ave Grand Junction, CO 81501 2945-114-17-013	Phyllis M. Carroll 1220 Cannell Ave. Grand Junction, CO 81501 2945-114-22-016
Albert & Eloy G. Garcia 853 Bunting Ave. Grand Junction, CO 81501 2945-114-17-006	Mary E. Berry, et al 836 Glenwood Ave. Grand Junction, CO 81501 2945-114-17-014	Clark L. & Jeanne R. Carroll 1240 Cannell Ave. Grand Junction, CO 81501 2945-114-22-017
Verna A Bennett 859 Bunting Ave. Grand Junction, CO 81501 2945-114-17-007	Paula B. & Gretchen Loshbaugh 824 Glenwood Ave. Grand junction, CO 81501 2945-114-17-015	
Jerrold T. Lynch 867 Bunting Ave. Grand Junction, CO 81501 2945-114-17-018	Stanley C. & Barbara L. Forrest 814 Glenwood Ave. Grand junction, Co 81501 2945-114-17-016	
A. M. & F. M. Hannewald 875 Bunting Ave. Grand Junction, CO 81501 2945-114-17-008	George T. & Mary Ann Ryan 804 Glenwood Ave. Grand Junction, CO 81501 2945-114-17-017	
George C. Jouflas 1275 Cannell Ave. Grand Junction, CO 81501 2945-114-17-009	Dorothy M. Laycock 760 Glenwood Ave. Grand Junction, CO 81501 2945-114-16-015	
August & Ann M. Pantuso 887 Bunting Ave. Grand Junction, CO 81501 2945-114-17-010	Howard & Helene Y. Shevlin 936 North Ave. Grand Junction, CO 81501 2945-114-22-012	
St. Mathews Parish P.O. Box 766 Grand Junction, CO 81501 2945-114-17-952	Medford Gerard Klein, et al 715 Victor Dr. Grand Junction, CO 81506 2945-114-22-013	



## Staff Report for Taco Bell

File # 27-90

### REZONE

850 North Avenue from C-1 to PB

845, 865 & 875 Glenwood Ave. from RSF-8 to PB

Petitioner wants to build a new modern Taco Bell Restaurant just west of their present building and redesign the drive-thru for better stacking of cars, then remove the old building and redesign the parking lot accordingly. The new building will seat 77 people inside with the potential of 26 seats in an outdoor dining area. By code a restaurant must provide 1 parking space per 3 persons designed seating capacity. With the new building built, only 19 spaces will fit on their lot. To provide for the remaining customer parking required and employee parking, the petitioner is requesting a rezone for the property across the alley at 845, 865 & 875 Glenwood Avenue for 38 parking spaces. This would give them a total of 57 spaces.

The North Avenue Corridor Guidelines allow office and multifamily uses on properties South of Glenwood Avenue. Thus Taco Bell's expansion of their parking area across the alley but still South of Glenwood Avenue is a compatible use. They are seeking a Planned Business (PB) zoning for the whole Taco Bell development.

1.) Petitioner originally wanted 2 exits onto Glenwood Ave. We requested they provide only 1 entrance/exit onto Glenwood Ave. The City Engineer wants an exit onto Glenwood Ave to help disperse traffic during peak periods and not force traffic to use the alley.

2.) To help make this parking area be more compatible to this residential neighborhood, we <sup>requested</sup> ~~required~~:

- extensive landscaping along Glenwood Avenue.
- 20' buffer between street and parking area.
- buffer area will be 3' high with 2' tall shrubs on top to create a 5' landscaped barrier.
- 6' privacy fence along East and West property line to screen parking from adjacent residential properties.
- A 12' strip of landscaping will extend from inside the fences to parking area on both the East and West.
- parking lot will have a minimal impact on Glenwood Ave. due to:
  - many customers will use alley for access to either parking area.
  - 50% of Taco Bell's business is through their drive-through which exits onto North Avenue.
  - there are currently 19 spaces located on the North Avenue site, using the code requirement of 1 space per 3 persons as an average, 57 people could be inside the restaurant and park on the existing site.
  - the Glenwood Avenue site will be for employee parking and an overflow for overflow customers during peak periods.
  - currently the employees are parking in the dirt lot which is accessed off the alley and Glenwood Ave. Under the current zoning this is illegal and will have to cease.

↳ code violation

3.) Parking is already a problem along Glenwood due to Mesa College students parking there. If Taco Bell is not allowed to build this parking lot they will have to cease all parking on the dirt lot now being used and park on Glenwood Ave. further complicating traffic concerns as they compete with students for parking spaces.

77  
+ 26  
103 SEATS  
34 SPACES  
3 | 103

4.) Why rezone 850 North Ave. from C-1 to PB?

-- allows us to look at the whole development:

parking	fencing
signage	access
drive through	landscaping, etc.

-- a conditional use permit would have to be obtained for the drive through on the new building, but now is part of the approval for the PB development.

5.) One letter opposing the Rezone - Greg Jouffas - 1275 Cannell Ave.

6.) One letter appealing the Final Plan - Howard & Lisa Roberts - 866 Glenwood Ave.

7.) One letter signed by 11 residents opposing the curb cut onto Glenwood Ave. which was approved in the Final Plan by Planning Commission.

- Landscaping is sufficient 21%
- North Ave. Corridor Guidelines Allows this type of use along the South Side of Glenwood Avenue.
- All Review Agency Comments have been resolved
- one written letter from Violet Owen in favor of project
- STAFF recommends Approval

Mike Saelens,

The representative for the petitioner Moss, Inc. has requested that he be allowed to present the details of the proposal to you (City Council)

(TACOBELL.RPT)

Along Glenwood Avenue, the west driveway ingress/egress areas needs to be eliminated. A maximum of one entrance/exit should be allowed on Glenwood Avenue.

There should be 20 feet of landscaping along Glenwood Avenue with a berm of 4 to 5 feet. Need to show berm on site plan.

\*\*

Open space fee is required prior to recording the final plan and other appropriate documents.

Planning clearance, sign permits, fence permit are required from our office before construction begins.

Improvements Agreements and Guarantees will be required for all curb, gutter, sidewalk improvements.

This project affects the following rezone criteria:

- There has been a change of character in the area due to new growth trends and deterioration of the area.
- The proposed rezone is compatible with the surrounding area.
- Benefits will be derived by the neighborhood and the community by cleaning up 3 deteriorated lots and improving them with landscaping and improvements which will eliminate the current problem of an eyesore and blowing dust.
- The proposal is in conformance with the policies, intents, and requirements of this code and the North Avenue Guidelines.
- Adequate facilities are available.

The North Avenue Corridor Guidelines suggest that office and multifamily residential uses may be appropriate on the south side of Glenwood Avenue to buffer the existing single family residential uses from commercial development. The proposed parking lot would be of similar impact as that of an office or multifamily uses. These uses would also have much of their property set aside for parking. In any case, more than the usual landscaping is needed to help buffer the parking area from the residential neighborhood on the west, north, and east sides. The parking lot will have some traffic impact on Glenwood, but not allowing access on Glenwood would force additional traffic on to the alley which is not designed for the same volumes of traffic that Glenwood Avenue is.

The landscaping standards are being met in area 1 as per the required 40% of the landscaped area shall contain shrubs, and this shrub area shall be covered by a minimum of 75% plant material. Area 2 does not have enough shrubs, but it is understood that this area is expected to change and be revised between now and the public hearing. The landscaping plan will need to be adjusted accordingly. Currently, there are enough trees and the plant sizes are okay for the entire development.

**REVIEW SHEET SUMMARY**

**FILE NO.** 27-90 **TITLE HEADING:** Taco Bell

**ACTIVITY:** Rezone & Revised Final Plan

**PETITIONER:** Moss Inc.

**REPRESENTATIVE:** Michael Saelens

**LOCATION:** 848 North Ave & 845-865 Glenwood Ave

**PHASE:** Final **ACRES:**

**PETITIONER'S ADDRESS:** 715 Horizon Drive, Suite 380

**ENGINEER:** Banner Engineer

Original  
Do NOT Remove  
From Office

-----  
**NOTE: WRITTEN RESPONSE BY THE PETITIONER TO THE REVIEW COMMENTS IS REQUIRED  
A MINIMUM OF 48 HOURS PRIOR TO THE FIRST SCHEDULED PUBLIC HEARING.**  
-----

#27-90 REZONE / TACO BELL (Page 1 of 3)

RESPONSE NECESSARY

by July 5, 1990

**06/12/90** **CITY PARKS & RECREATION**

Attached appraisal is not detailed and appears to be on the low side compared to some others from other parts of town. \$32,214 x 5% = \$1,610.70 open space fees.

**06/11/90** **BUILDING DEPARTMENT**

No comments or objections.

**06/11/90** **U.S. WEST**

No comments.

**06/12/90** **CITY ENGINEER**

Each handicap parking space and unloading area should be 17' wide. Unloading area and curb ramps should be on the right side of each handicap parking space.

Curbing along east side of the building lot should allow for 2' vehicle overhang between face of curb and property line. Only 1' is provided on site plan.

The type and location of all traffic control signs should be shown on the site plan. Stop signs will be required at all exits onto North Avenue, the alley and Glenwood Avenue.

The proposed drive-thru lane will allow stacking for only three vehicles behind the ordering microphone without blocking the parking lot aisle and/or parking spaces. Is there a way to separate the drive-thru lane from the parking lot?

Curb radii at alley entrances and exits range from 4.5' to 7.5'. Where possible these should be increased to at least 10'.

In the north parking lot, I would like to see the space between the west property line and the proposed curb increased to 10'. This would allow better alignment of the driveways crossing the alley and would provide enough width for landscaping in the space between the curb and property line. This could be done by removing three parking spaces from the center of the lot.

06/12/90      CITY ENGINEER continued

We need to see a plan showing parking lot lighting coverage and the type of light fixture proposed. What is the proposed screen wall/fence? Show detail on plan.

All landscaping within 5' of a public sidewalk or within 10' of the alley pavement shall be under 30 inches in height.

All drainage troughs constructed in the public right-of-way shall be in accordance with City Standard Drawing ST-2.

All unused curb cuts on North Avenue and Glenwood Avenue shall be removed and replaced with curb, gutter, and sidewalk to match existing.

The sidewalk on the south side of the north parking lot is not wide enough to allow for vehicle overhang. (Should be 6' min.)

There should be a designated crosswalk for pedestrians to cross the alley. Sidewalks and handicap ramps should be installed at the approaches to the crosswalk.

06/18/90      CITY POLICE DEPARTMENT

No problems noted.

06/18/90      PUBLIC SERVICE

GAS: No objections. G.L. 6/18/90

ELECTRIC: No objections. F.B. 6/15/90

06/19/90      CITY PROPERTY AGENT

Request for Revocable Permit to allow the installation of landscape improvements in the North Avenue right-of-way will be scheduled for the July 18th City Council meeting.

Signs adjacent to all driveways need to be installed at no more than 30 inches above the grade of the ground (see Section 5-3-2 Zoning & Development Code).

06/19/90      CITY UTILITIES ENGINEER

Adequate water and sewer facilities exist to accommodate the expanded facility as proposed. The new E.Q.U. for calculating "Plant Investment Fees" and monthly service charges will be 11.20. The new facility will require review by the City for industrial pretreatment.

The Utilities Division of the Public Works Department has no objection to the rezone.

06/18/90      CITY FIRE DEPARTMENT

Our department doesn't have a problem with this rezone at this time. A fire flow survey needs to be conducted to determine adequate water for fire emergency. A set of building plans is required for this survey. Access appears to be adequate at this time. Lot # 15 is shown on the rezone, but there isn't any mention of its use. I would like that shown on a plat plan or in the written description. If you have any questions please call. George Bennett, 244-1401.

06/20/90      CITY ATTORNEY

None.

06/20/90      CITY PLANNING DEPARTMENT

Need more detail on screening/fencing. The code requires the screening to be 6' whether it is a solid fence or solid year-round landscaping. Need to know height, type of construction, etc.

Need more signage detail on plan - re: type, size, and location.

Need more information on parking lot lighting. Needs to be low impact lighting. Lighting facilities must be directed away from residential property and the vision of passing motorists. Need to know type and location of lighting on site plan.

Along Glenwood Avenue, the west driveway ingress/egress areas needs to be eliminated. A maximum of one entrance/exit should be allowed on Glenwood Avenue.

There should be 20 feet of landscaping along Glenwood Avenue with a berm of 4 to 5 feet. Need to show berm on site plan.

\*\*

Open space fee is required prior to recording the final plan and other appropriate documents.

Planning clearance, sign permits, fence permit are required from our office before construction begins.

Improvements Agreements and Guarantees will be required for all curb, gutter, sidewalk improvements.

This project affects the following rezone criteria:

- There has been a change of character in the area due to new growth trends and deterioration of the area.
- The proposed rezone is compatible with the surrounding area.
- Benefits will be derived by the neighborhood and the community by cleaning up 3 deteriorated lots and improving them with landscaping and improvements which will eliminate the current problem of an eyesore and blowing dust.
- The proposal is in conformance with the policies, intents, and requirements of this code and the North Avenue Guidelines.
- Adequate facilities are available.

The North Avenue Corridor Guidelines suggest that office and multifamily residential uses may be appropriate on the south side of Glenwood Avenue to buffer the existing single family residential uses from commercial development. The proposed parking lot would be of similar impact as that of an office or multifamily uses. These uses would also have much of their property set aside for parking. In any case, more than the usual landscaping is needed to help buffer the parking area from the residential neighborhood on the west, north, and east sides. The parking lot will have some traffic impact on Glenwood, but not allowing access on Glenwood would force additional traffic on to the alley which is not designed for the same volumes of traffic that Glenwood Avenue is.

The landscaping standards are being met in area 1 as per the required 40% of the landscaped area shall contain shrubs, and this shrub area shall be covered by a minimum of 75% plant material. Area 2 does not have enough shrubs, but it is understood that this area is expected to change and be revised between now and the public hearing. The landscaping plan will need to be adjusted accordingly. Currently, there are enough trees and the plant sizes are okay for the entire development.

REVIEW SHEET SUMMARY  
CITY ENGINEER  
RESPONSE

- 1) THE SITE PLAN HAS BEEN AMENDED TO SHOW THE CORRECT DIMENSIONS FOR THE HANDICAP PARKING SPACE.
- 2) THE SITE PLAN HAS BEEN CHANGED TO REFLECT 2' ALONG THE EAST SIDE OF BUILDING PARKING LOT.
- 3) THE SITE PLAN NOW SHOWS ALL TRAFFIC CONTROL SIGNS.
- 4) WE ARE AWARE OF YOUR CONCERN FOR THE STACKING IN THE DRIVE-THRU LANE. WE FEEL FROM PAST EXPERIENCE IT WILL NOT POSE A PROBLEM. OUR GOAL IS TO HANDLE EACH AUTO IN THE DRIVE-THRU IN APPROX. 45 SECONDS PER CAR.
- 5) CURB RADII HAVE BEEN CHANGED INCREASED WHERE POSSIBLE TO 10'.  
(SEE REVISED SITE PLAN)
- 6) THE SPACE IN THE NORTH PARKING LOT HAS BEEN INCREASED TO 12'. THE DRIVEWAYS CROSSING THE ALLEY HAVE BEEN ALIGNED.  
(SEE REVISED SITE PLAN)
- 7) WE HAVE HAD A ENGINEER SHOW THE CORRECT LIGHTING FIXTURES. THE LIGHTING FACILITIES WILL BE DIRECTED AWAY FROM RESIDENTIAL. SEE DIAGRAM ON SITE PLAN FOR TYPE OF FENCING.
- 8) SEE SITE PLAN ATTACHMENT FOR SIGNAGE DETAIL.
- 9) ALL LANDSCAPING WITHIN 5' OF PUBLIC SIDEWALK AND 10' OF THE ALLEY WILL BE UNDER 30 INCHES IN HEIGHT.  
(SEE REVISED LANDSCAPE PLAN).
- 10) ALL DRAINAGE TROUGHS WILL BE CONSTRUCTED IN ACCORDANCE WITH CITY STANDARD DRAWING ST-2. SEE SITE PLAN INSERT.
- 11) ALL UNUSED CURB CUTS ON NORTH AVE. AND GLENWOOD AVE. WILL BE REMOVED AND REPLACED WITH CURB, GUTTER, AND SIDEWALK TO MATCH EXISTING.
- 12) THE SIDEWALK ON THE SOUTH SIDE OF NORTH PARKING LOT HAS BEEN DESIGNED TO BE 6' WIDE TO ALLOW FOR VEHICLE OVERHANG.  
(SEE REVISED SITE PLAN)
- 13) THERE WILL BE A DESIGNATED CROSSWALK FOR PEDESTRIANS TO CROSS ALLEY  
(SEE REVISED SITE PLAN).

RECEIVED GRAND JUNCTION  
PLANNING DEPARTMENT

JUL 05 1990

REVIEW SHEET SUMMARY  
CITY PLANNING DEPARTMENT  
RESPONSE

- 1) THE SCREENING/FENCING WILL BE 6' HIGH. SEE SITE PLAN INSERT FOR FENCING DIAGRAM.
- 2) MORE SIGNAGE DETAIL HAS BEEN ADDED TO SITE PLAN.  
(SEE REVISED SITE PLAN)
- 3) WE HAVE HAD ENGINEER DESIGN PARKING LOT LIGHTING. LIGHT WILL BE DIRECTED AWAY FROM RESIDENTIAL PROPERTIES. (SEE ATTACHMENT TO SITE PLAN).
- 4) THE WEST DRIVEWAY ALONG GLENWOOD HAS BEEN ELIMINATED. WE NOW HAVE ONLY ONE EXIT/ENTRANCE ON TO GLENWOOD. NOTE THE EXIT ALLOWS FOR RIGHT TURN ONLY. (SEE REVISED SITE PLAN).
- 5) THE BERM ALONG GLENWOOD HAS BEEN WIDENED TO APPROX 20". THE BERM PLUS LANDSCAPE HEDGE WILL BE 5' TO 6' HIGH. (SEE REVISED LANDSCAPE PLAN).

RECEIVED GRAND JUNCTION  
PLANNING DEPARTMENT

JUL 05 1990



# development summary



File # 27-90 Name Taco Bell Date July 10, 1990

PROJECT LOCATION: 850 North Avenue and 845, 865, & 875 Glenwood Avenue

## PROJECT DESCRIPTION:

Rezone from C-1 (Light Commercial) to PB (Planned Business) at 850 North Avenue and from RSF-8 (Residential Single Family with a density of 8 units per acre maximum) to PB (Planned Business) at 845, 865, & 875 Glenwood Avenue.

## REVIEW SUMMARY (Major Concerns)

POLICIES COMPLIANCE			TECHNICAL REQUIREMENTS		
	YES	NO*		SATISFIED	NOT SATISFIED*
Complies with adopted policies	X		Streets/Rights Of Way	X	
Complies with adopted criteria	X		Water/Sewer	X	
Meets guidelines of Comprehensive Plan	X		Irrigation/Drainage	X	
			Landscaping/Screening	X	
			Other: _____		

\* See explanation below

## STATUS & RECOMMENDATIONS:

Planning Commission and staff recommend approval of the rezones subject to the review agency sheet comments. The final plan has been approved with the addition of one handicap parking space.

## Planning Commission Action

Recommend approval of Rezones. (6-0)

FF



**ACTION SHEET**

Do Not Return  
From Office #27 90

ACRES \_\_\_\_\_

UNITS

DENSITY

ACTIVITY REZONE TACO Bell From C-1 to PB (848 North Ave) & REZONE Property

PHASE AT 845 thru 865 From RSF-8 to PB ALSO ALLOWING A LARGER PLANNED DEVELOPMENT FOR TACO BELL FINAL PLAN FOR RESTAURANT USE

COMMON LOCATION 848050 NORTH AVENUE & 845, 865, 875 Glenwood Avenue

DATE SUBMITTED \_\_\_\_\_ DATE MAILED OUT \_\_\_\_\_ DATE POSTED \_\_\_\_\_

\_\_\_\_\_ DAY REVIEW PERIOD RETURN BY \_\_\_\_\_

OPEN SPACE DEDICATION (acreage) \_\_\_\_\_ OPEN SPACE FEE REQUIRED \$ \_\_\_\_\_ PAID RECEIPT # \_\_\_\_\_

RECORDING FEE REQUIRED \$ \_\_\_\_\_ PAID (Date) \_\_\_\_\_ DATE RECORDED \_\_\_\_\_

**REZONE AND FINAL**

FILE NUMBER \_\_\_\_\_

ZONE C-1 & RSF-8 to PB

TAX SCHEDULE # 2945-114-19  
205  
026  
027  
023

**REVIEW AGENCIES**

	A	B	C	D	E	F	G	H	I	J	K	L	M	N	O	P	Q	R	S	T	U	V	W	X	Y	Z	AA	BB	CC	DD	EE	FF	GG
<input checked="" type="checkbox"/> Planning Department	●	●	●	●	●	●	●	●	●	●	●	●	●	●	●	●	●	●	●	●	●	●	●	●	●	●	●	●	●	●	●	●	
<input checked="" type="checkbox"/> City Engineer	●	●	●	●	●	●	●	●	●	●	●	●	●	●	●	●	●	●	●	●	●	●	●	●	●	●	●	●	●	●	●	●	
<input type="checkbox"/> Transportation Engineer	●	●	●	●	●	●	●	●	●	●	●	●	●	●	●	●	●	●	●	●	●	●	●	●	●	●	●	●	●	●	●	●	
<input checked="" type="checkbox"/> City Parks/Recreation	●	●	●	●	●	●	●	●	●	●	●	●	●	●	●	●	●	●	●	●	●	●	●	●	●	●	●	●	●	●	●	●	
<input checked="" type="checkbox"/> City Fire Department	●	●	●	●	●	●	●	●	●	●	●	●	●	●	●	●	●	●	●	●	●	●	●	●	●	●	●	●	●	●	●	●	
<input checked="" type="checkbox"/> City Police Department	●	●	●	●	●	●	●	●	●	●	●	●	●	●	●	●	●	●	●	●	●	●	●	●	●	●	●	●	●	●	●	●	
<input type="checkbox"/> County Planning	●	●	●	●	●	●	●	●	●	●	●	●	●	●	●	●	●	●	●	●	●	●	●	●	●	●	●	●	●	●	●	●	
<input type="checkbox"/> County Engineer	●	●	●	●	●	●	●	●	●	●	●	●	●	●	●	●	●	●	●	●	●	●	●	●	●	●	●	●	●	●	●	●	
<input type="checkbox"/> County Health	●	●	●	●	●	●	●	●	●	●	●	●	●	●	●	●	●	●	●	●	●	●	●	●	●	●	●	●	●	●	●	●	
<input type="checkbox"/> Floodplain Administration	●	●	●	●	●	●	●	●	●	●	●	●	●	●	●	●	●	●	●	●	●	●	●	●	●	●	●	●	●	●	●	●	
<input type="checkbox"/> G.J. Dept. of Energy	●	●	●	●	●	●	●	●	●	●	●	●	●	●	●	●	●	●	●	●	●	●	●	●	●	●	●	●	●	●	●	●	
<input type="checkbox"/> Walker Field	●	●	●	●	●	●	●	●	●	●	●	●	●	●	●	●	●	●	●	●	●	●	●	●	●	●	●	●	●	●	●	●	
<input type="checkbox"/> School District	●	●	●	●	●	●	●	●	●	●	●	●	●	●	●	●	●	●	●	●	●	●	●	●	●	●	●	●	●	●	●	●	
<input type="checkbox"/> Irrigation	●	●	●	●	●	●	●	●	●	●	●	●	●	●	●	●	●	●	●	●	●	●	●	●	●	●	●	●	●	●	●	●	
<input type="checkbox"/> Drainage	●	●	●	●	●	●	●	●	●	●	●	●	●	●	●	●	●	●	●	●	●	●	●	●	●	●	●	●	●	●	●	●	
<input type="checkbox"/> Water (Ute, Clifton)	●	●	●	●	●	●	●	●	●	●	●	●	●	●	●	●	●	●	●	●	●	●	●	●	●	●	●	●	●	●	●	●	
<input type="checkbox"/> Sewer Dist. (FV, CGV, OM)	●	●	●	●	●	●	●	●	●	●	●	●	●	●	●	●	●	●	●	●	●	●	●	●	●	●	●	●	●	●	●	●	
<input checked="" type="checkbox"/> U.S. West	●	●	●	●	●	●	●	●	●	●	●	●	●	●	●	●	●	●	●	●	●	●	●	●	●	●	●	●	●	●	●	●	
<input checked="" type="checkbox"/> Public Service (2 sets)	●	●	●	●	●	●	●	●	●	●	●	●	●	●	●	●	●	●	●	●	●	●	●	●	●	●	●	●	●	●	●	●	
<input type="checkbox"/> State Highway Department	●	●	●	●	●	●	●	●	●	●	●	●	●	●	●	●	●	●	●	●	●	●	●	●	●	●	●	●	●	●	●	●	
<input type="checkbox"/> State Geological	●	●	●	●	●	●	●	●	●	●	●	●	●	●	●	●	●	●	●	●	●	●	●	●	●	●	●	●	●	●	●	●	
<input type="checkbox"/> State Health Department	●	●	●	●	●	●	●	●	●	●	●	●	●	●	●	●	●	●	●	●	●	●	●	●	●	●	●	●	●	●	●	●	
<input checked="" type="checkbox"/> City Property Agent	●	●	●	●	●	●	●	●	●	●	●	●	●	●	●	●	●	●	●	●	●	●	●	●	●	●	●	●	●	●	●	●	
<input checked="" type="checkbox"/> City Utilities Engineer	●	●	●	●	●	●	●	●	●	●	●	●	●	●	●	●	●	●	●	●	●	●	●	●	●	●	●	●	●	●	●	●	
<input checked="" type="checkbox"/> City Attorney	●	●	●	●	●	●	●	●	●	●	●	●	●	●	●	●	●	●	●	●	●	●	●	●	●	●	●	●	●	●	●	●	
<input checked="" type="checkbox"/> Building Department	●	●	●	●	●	●	●	●	●	●	●	●	●	●	●	●	●	●	●	●	●	●	●	●	●	●	●	●	●	●	●	●	
<input type="checkbox"/> DDA	●	●	●	●	●	●	●	●	●	●	●	●	●	●	●	●	●	●	●	●	●	●	●	●	●	●	●	●	●	●	●	●	
<input checked="" type="checkbox"/> GJPC (7 packets)	●	●	●	●	●	●	●	●	●	●	●	●	●	●	●	●	●	●	●	●	●	●	●	●	●	●	●	●	●	●	●	●	
<input checked="" type="checkbox"/> CIC (11 packets)	●	●	●	●	●	●	●	●	●	●	●	●	●	●	●	●	●	●	●	●	●	●	●	●	●	●	●	●	●	●	●	●	
<input type="checkbox"/> Other	●	●	●	●	●	●	●	●	●	●	●	●	●	●	●	●	●	●	●	●	●	●	●	●	●	●	●	●	●	●	●	●	

TOTALS	30	30	30	30	30	30	30	30	30	30	30	30	30	30	30	30	30	30	30	30	30	30	30	30	30	30	30	30	30	30	30
--------	----	----	----	----	----	----	----	----	----	----	----	----	----	----	----	----	----	----	----	----	----	----	----	----	----	----	----	----	----	----	----

BOARDS	DATE	REMARKS
P.C.	7-10-90	REZONE Approved 6-2 ; PLAN Approved 4-2
C.C.	7-18-90	REZONE Tabled 7-0
C.C.	8-1-90	FINAL PLAN 5-0 REZONE 3-2 <i>Approved</i>
STAFF	5/8/91	Minor Change Approved



APPLICATION FEE REQUIREMENTS  
REZONE & FINAL - \$500.00 due at submittal

\* ORIGINAL FORMS WITH SIGNATURES INCLUDE IN PLANNING DEPT. PACKET \*



Grand Junction Community Development Department  
Planning • Zoning • Code Enforcement  
250 North Fifth Street  
Grand Junction, Colorado 81501-2668  
(303) 244-1430 FAX (303) 244-1599

June 4, 1991

Mike Saelens  
Moss, Inc.  
715 Horizon Drive  
Suite 380  
Grand Junction, Colorado 81506

RE: Site inspection for Taco Bell Restaurant at 850 North Avenue

Dear Mr. Saelens:

Don Newton, City Engineer, and I inspected the Taco Bell site at 850 North Avenue on Tuesday, June 4th, 1991 and found the site acceptable with the following exception:

1) The sidewalk crossing drain on Glenwood Avenue does not meet City standards and must be replaced. (See copy of ST-2 drawing enclosed.)

also, the following still need to be completed:

2) The installation of Six -Stop signs (#R1-1, 24" x 24"), one - No Left Turn sign (#R3-2) on Glenwood and at your option two - Pedestrian crossing signs (#W11A-2, 30" x 30") along the alley. The City Traffic Engineer, Dave Tontoli will contact you regarding the pedestrian alley crossing. All sign locations and heights must be approved by the City Traffic Engineer. His phone number is 244-1567.

I would like to add that the landscaping and site design along with the interior and exterior of the building have been done beautifully and are to be commended. We appreciate the example you are setting for other commercial establishments in town and hope that many others will follow. Your site is one that as residents of Grand Junction we all can be proud of.

If you have any further questions please contact me at your earliest convenience.

Respectfully,

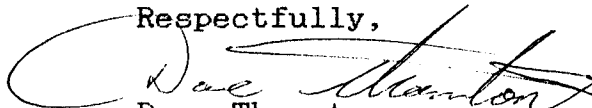
  
Dave Thornton  
Planner

cc: Don Newton  
file #27-90

GREGORY JOUFLAS  
1275 Cannell Avenue  
Grand Junction, CO 81501

0661 91 701  
RECEIVED GRAND JUNCTION  
PLANNING DEPARTMENT

July 16, 1990

City Council  
City of Grand Junction  
City Hall  
250 North 5th Street  
Grand Junction, CO 81501

RECEIVED

JUL 16, 1990

Re: Rezone for Taco Bell  
Petitioner Moss, Inc.,  
845, 865 and 875  
Glenwood Avenue

Dear Council Members:

I own the property located at 1275 Cannell Avenue, in Grand Junction, and occupy that property as my residence. The proposed parking lot which Taco Bell wishes to construct at 845, 865 and 875 Glenwood Avenue is just around the corner from my home, and I have a number of concerns regarding Taco Bell's request for rezone for its parking lot.

Specifically, there can be no question that construction of a parking lot on Glenwood Avenue, as sought by Taco Bell, will increase the volume of traffic on both Glenwood Avenue and Cannell Avenue. Increased traffic will obviously bring with it increased noise, litter, and congestion on both Cannell Avenue and Glenwood Avenue. These impacts on the area surrounding Taco Bell's proposed parking lot are unavoidable, and are an obvious consequence of commercial use of a property such as a parking lot for a high volume fast food business like Taco Bell. The existence of such a commercial use is simply incompatible and inconsistent with the residential nature of the properties fronting on Glenwood Avenue and Cannell Avenue. Placement of a parking lot where proposed by Taco Bell would be a significant intrusion into the neighborhood, would degrade the residential nature of the area, and be wholly inconsistent with the residential character which now exists along Glenwood Avenue and Cannell Avenue.

I also have serious concerns about use of the proposed parking lot on Glenwood Avenue by persons other than Taco Bell

City Council  
July 16, 1990  
Page 2

customers, particularly after business hours. As the City Council is well aware, there is significant "cruiser" traffic on North Avenue during the evenings, particularly on Fridays and Saturdays. Such activity includes use of parking areas along North Avenue as places where these people can listen to loud music, consume alcoholic beverages, and create significant traffic noise and other disturbances. One need only drive past the Vickers' station at North and 10th on a Friday or Saturday night to appreciate the seriousness and scope of this problem. Construction of the proposed Taco Bell parking lot along Glenwood Avenue would create an inviting location for the same sort of activities that now take place at the Vickers station. In addition to this problem, the proposed plan for the parking lot includes planting of large grassy areas, and installation of benches or tables which would act as a further invitation for after hours use of the property by unauthorized persons. This also creates the potential for disturbances of the surrounding residences. Given the potential for such use of a parking lot on Glenwood Avenue, and the problems with noise, traffic, and other disturbances during the evening hours such a parking lot would create, the proposed parking lot is inappropriate for the residential area in which Taco Bell seeks to place the lot.

In light of the foregoing concerns, and the simple fact that a parking lot is completely inconsistent with the residential character of the neighborhoods along Glenwood Avenue and Cannell Avenue, I am adamantly opposed to any rezone which would allow Taco Bell to construct the proposed parking lot, regardless of the design of such a facility. I ask that the City Council deny Taco Bell's request for rezoning of 845, 865 and 875 Glenwood Avenue for any use as a parking lot.

Sincerely,

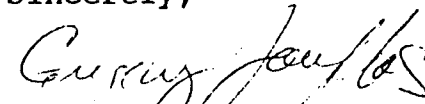
  
Gregory Joufflas

TO: FILE # 27-90 (Taco Bell)  
FROM: Dave Thornton, Planner *DST*  
Date: September 25, 1990  
Subject: Approved Pole Sign

Taco Bell received State Highway's response to development in the ROW along North Avenue after the City Council meeting held on August 1, 1990. In the Highway Department's letter they mention that no advertising signs are allowed, therefore Taco Bell has moved their pole sign a short distance to the North and West on the Final Site Plan to be located on their property but still out in front of their building. This new site for the sign does necessitate the removal of one tree that was planned for that location. Only this new site plan will be recorded.



Moss Inc.  
Sierra Be  
A Franchisee of Taco Bell Corp.  
715 Horizon Drive, Suite 380  
Grand Junction, Colorado 81506

June 7, 1991

Dave Thornton  
Grand Junction Planning  
250 North Fifth Street  
Grand Junction, CO. 81501

Mr. Thornton,

I am writing this letter in response to the letter I received from the Planning Department June 4, 1991.

There were two concerns to the city planning regarding the Taco Bell at 850 North Ave. Grand Junction.

- 1) The sidewalk crossing drain on Glenwood Ave. has been installed incorrectly. It will be corrected according to ST-2 specifications on or before July 1, 1991.
- 2) The stop signs have been installed on the site. The poles for the right turn only sign and pedestrian crossing signs have been installed. The signs for these poles were not available, but have been ordered. They should be installed in 7-10 days.

I hope this will answer your concerns.

Thank you for your cooperation.

Sincerely,

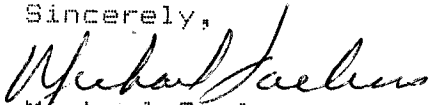
  
Michael Saelens  
Real Estate & Development  
Moss Inc.

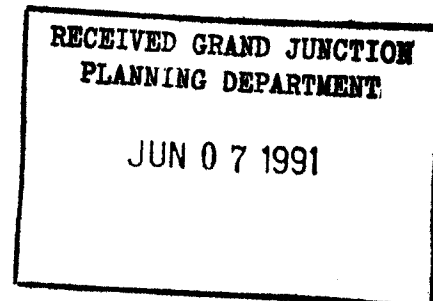



Grand Junction Community Development Department  
Planning • Zoning • Code Enforcement  
250 North Fifth Street  
Grand Junction, Colorado 81501-2668  
(303) 244-1430 FAX (303) 244-1599

September 6, 1991

Mike Saelens  
Moss, Inc.  
A Franchise of Taco Bell Corp.  
715 Horizon Drive, Suite 380  
Grand Junction, Colorado 81506

RE: Sidewalk Crossing Drain on Glenwood Avenue

Dear Mike:

On September 5, 1991 Don Newton, City Engineer and myself inspected the sidewalk crossing drain on Glenwood Avenue north of the parking lot for Taco bell at 850 North Avenue. We found that the drain had not been reconstructed as promised. This needs to be completed as soon as possible. Please let me know when we can expect this to be done.

Respectfully,

A handwritten signature in black ink, appearing to read "Dave Thornton", is written over a large, stylized flourish.

Dave Thornton  
Planner

cc: Don Newton, city Engineer  
File #27-90