

Table of Contents

File COU-1995-004.7

Date 7/14/99

P r e s e n t	S c a n n e d	<p>A few items are denoted with a (*) are to be scanned for permanent record on the ISYS retrieval system. In some instances, not all entries designated to be scanned, are present in the file. There are also documents specific to certain files, not found on the standard list. For this reason, a checklist has been included.</p> <p>Remaining items, (not selected for scanning), will be marked present on the checklist. This index can serve as a quick guide for the contents of each file.</p> <p>Files denoted with (**) are to be located using the ISYS Query System. Planning Clearance will need to be typed in full, as well as other entries such as Ordinances, Resolutions, Board of Appeals, and etc.</p>
---------------------------------	---------------------------------	--

X	X	*Summary Sheet – Table of Contents
---	---	---

	X	Application form
--	---	------------------

		Receipts for fees paid for anything
--	--	-------------------------------------

X	X	*Submittal checklist
---	---	-----------------------------

		*General project report
--	--	--------------------------------

		Reduced copy of final plans or drawings
--	--	---

		Reduction of assessor's map
--	--	-----------------------------

		Evidence of title, deeds
--	--	--------------------------

		*Mailing list to adjacent property owners
--	--	--

		Public notice cards
--	--	---------------------

		Record of certified mail
--	--	--------------------------

		Legal description
--	--	-------------------

		Appraisal of raw land
--	--	-----------------------

		Reduction of any maps – final copy
--	--	------------------------------------

		*Final reports for drainage and soils (geotechnical reports)
--	--	---

		Other bound or nonbound reports
--	--	---------------------------------

		Traffic studies
--	--	-----------------

X		Individual review comments from agencies
---	--	--

X	X	*Consolidated review comments list
---	---	---

X		*Petitioner's response to comments
---	--	---

		*Staff Reports
--	--	-----------------------

		*Planning Commission staff report and exhibits
--	--	---

		*City Council staff report and exhibits
--	--	--

		*Summary sheet of final conditions
--	--	---

		*Letters and correspondence dated after the date of final approval (pertaining to change in conditions or expiration date)
--	--	---

DOCUMENTS SPECIFIC TO THIS DEVELOPMENT FILE:

X	X	Planning Clearance **
---	---	-----------------------

X	X	Site Plan – unsigned, not stamped
---	---	-----------------------------------

X		Pictures of the warehouse
---	--	---------------------------

X		Letter to City from Thomas M. Herbert
---	--	---------------------------------------

X		Assessor's map
---	--	----------------

--	--	--

--	--	--

--	--	--

--	--	--

--	--	--

--	--	--

--	--	--

--	--	--

--	--	--

--	--	--

--	--	--

--	--	--

--	--	--

--	--	--

--	--	--

--	--	--

--	--	--

--	--	--

--	--	--

--	--	--

--	--	--

--	--	--

--	--	--

--	--	--

--	--	--

--	--	--

--	--	--

--	--	--

--	--	--

--	--	--

--	--	--

--	--	--

DATE SUBMITTED: August 16, 1995

**CHANGE OF USE
DEVELOPMENT APPLICATION**

PROPERTY OWNER: Coors Energy Company
ADDRESS: P.O. Box 467 Golden, CO. 80402
PHONE: 303-277-3458

APPLICANT'S NAME: Conservation O.T. Co. of Grand Junction, Inc.
ADDRESS: P.O. Box 1677 G.J. CO 81502
PHONE: 970-243-6934

LOCATION OF: 825 First St, G.J
TAX PARCEL: 2945 231 01 01, 020, 024, 022

EXISTING USE: ①
PROPOSED USE: ②
OTHER: _____

ZONE: I-M SETBACK: _____
SPECIAL COMMENTS: _____

I HEREBY ACKNOWLEDGE THAT I HAVE READ THIS APPLICATION AND THE ABOVE IS CORRECT AND I AGREE TO COMPLY WITH ALL REQUIREMENTS. FAILURE TO COMPLY SHALL RESULT IN LEGAL ACTION.

Thomas M. Herbert
Signature

APPROVED BY: Kathy Portner

DATE APPROVED: 9/5/95

- ① Existing Use - Vacant, Formerly used for Manufacturing of Cellulose Thermal Insulation.
- ② Wholesale Motor O.T. & Lubricants Distribution.

~~Proposed~~ ~~Project~~

Date: 8/15/96

Proposal: Manhole at Locality

Location: 825 1st Ave

Tax Parcel Number: 2445 231 01 011, 2445 231 01 020

2445 231 01 021

2445 231 01 022

Related Files: _____

Additional ROW required? _____

TCP/Adjacent Half street improvements? _____

Revocable Permit required? _____

State Highway Access Permit required? _____

On-site detention/retention or Drainage fee required? _____

Applicable Plans, Policies and Guidelines _____

Located in identified floodplain? FIRM panel # _____

Located in other geohazard area? _____

Located in established Airport Zone? Clear Zone, Critical Zone, Area of Influence? _____

Avigation Easement required? _____

Related Files: _____

REVIEW COMMENTS

Page 1 of 1

FILE #COU-95-4.7

TITLE HEADING: Change of Use -
manufacturing of insulation
to motor oil/lubricants
distribution

LOCATION: 825 First Avenue

PETITIONER: Conservancy Oil of Grand Junction

PETITIONER'S ADDRESS/TELEPHONE: P.O. Box 1677
Grand Junction, CO 81502
243-6934

PETITIONER'S REPRESENTATIVE: Frank E. Peabody

STAFF REPRESENTATIVE: Kathy Portner

NOTE: THE PETITIONER IS REQUIRED TO SUBMIT FOUR (4) COPIES OF WRITTEN RESPONSE AND REVISED DRAWINGS ADDRESSING ALL REVIEW COMMENTS.

COMMUNITY DEVELOPMENT DEPT. 8/23/95
Kathy Portner 244-1446

1. Must meet all Fire and Building Codes.
2. Confirm there will be no outdoor storage.
3. *Please submit original change on the permit*

GRAND JUNCTION FIRE DEPARTMENT 8/25/95
Hank Masterson 244-1414

1. This proposal is acceptable to the Fire Department as long as the total amount of Class III-B combustible liquids stored is kept below 13,200 gallons. If the number of 1000 gallon tanks increases to 10, the total amount stored will exceed this exempt amount-requiring control areas to be constructed in the building as per the building code.
2. The proposed containment area is acceptable and is of adequate size for the 48" diameter tanks proposed. These tanks must be listed for use as above ground tanks.
3. There will be dispensing of III-B liquids into and from the 1000 gallon tanks. If the dispensing is through open systems, the maximum quantity allowed is 3300 gallons.
4. A permit is required from the Colorado Department of Labor and Employment-Oil Inspection Section for the installation of any tank larger than 660 gallons. The installation must comply with State requirements.
5. Fire Department access is adequate. Existing hydrants and water lines are acceptable.

CITY DEVELOPMENT ENGINEER 8/28/95
Jody Kliska 244-1591

1. What was prior use?
2. What is anticipated traffic - how many trucks/day, number of employees at site, office hours?

CITY UTILITY ENGINEER
Trent Prall

8/28/95
244-1590

Milly Fowler *No Fees*

Sewer: City

1. Please contact Utility Billing (244-1580) for more information regarding potential change in plant investment fees for sewer. The following information will be requested by Utility Billing: 1. number of employees.
2. Please provide information on containment of spills. Facilities should be in place to ensure no spills will enter sewer or storm drain systems.

Water: City

1. 1" Tap already on site.

RESPONSE TO REVIEW COMMENTS

FILE: #COU-95-4.7

LOCATION: 825 FIRST AVENUE

PETITIONER: CONSERVANCY OIL OF GRAND JUNCTION

PETITIONER'S ADDRESS/TELEPHONE: P.O. BOX 1677
GRAND JUNCTION, CO 81502
243-6934

COMMUNITY DEVELOPMENT DEPARTMENT

1. To the best of our knowledge the property and building meet all fire and building codes.
2. There will be no outside storage of products. Empty drums and empty pallets will be stacked neatly in the enclosed yard prior to reuse, return, recycle, or disposal.
3. Original change in use report - Please see attached.

GRAND JUNCTION FIRE DEPARTMENT

1. Amount of Class III-B combustible liquids will be kept below 13,200 gallons. If the bulk storage increases to 10,000 gallons, control areas will be constructed as per the building codes.
2. The tanks are listed for use as above ground tanks.
3. Dispensing and receiving of Class III-B liquids will be through a closed system except for small quantities.
4. Verbal approval of the tank installation has been received from the State Oil Inspection Section. (Mr. Butch Gordley)

CITY DEVELOPMENT ENGINEER

1. Prior use was a cellulose insulation manufacturing facility.
2. There are two employees on site. Our one delivery truck will load, deliver and return on the average of once a day. Trucks delivering from suppliers will average about two per week. Office hours are 7:30am to 4:30pm Monday through Friday.

No TCP

CITY UTILITY ENGINEER

1. Utility Billing has been contacted concerning the number of employees.
2. Containment of spills - All product transfer and storage will be done within the building using closed systems other than for small quantities. Any spillage will be contained using floor-dry and other portable containment systems. Bulk storage tanks will be within an approved containment area. The nearest storm drain is approximately fifty feet from the building which provides adequate distance for containment before spills would enter the storm drains.

O.K. as per sheet

MAYS CONSTRUCTION
SPECIALTIES INC.
P.O. Box 4188
Grand Junction, CO 81502
303-243-5668

REV.
8/10/01

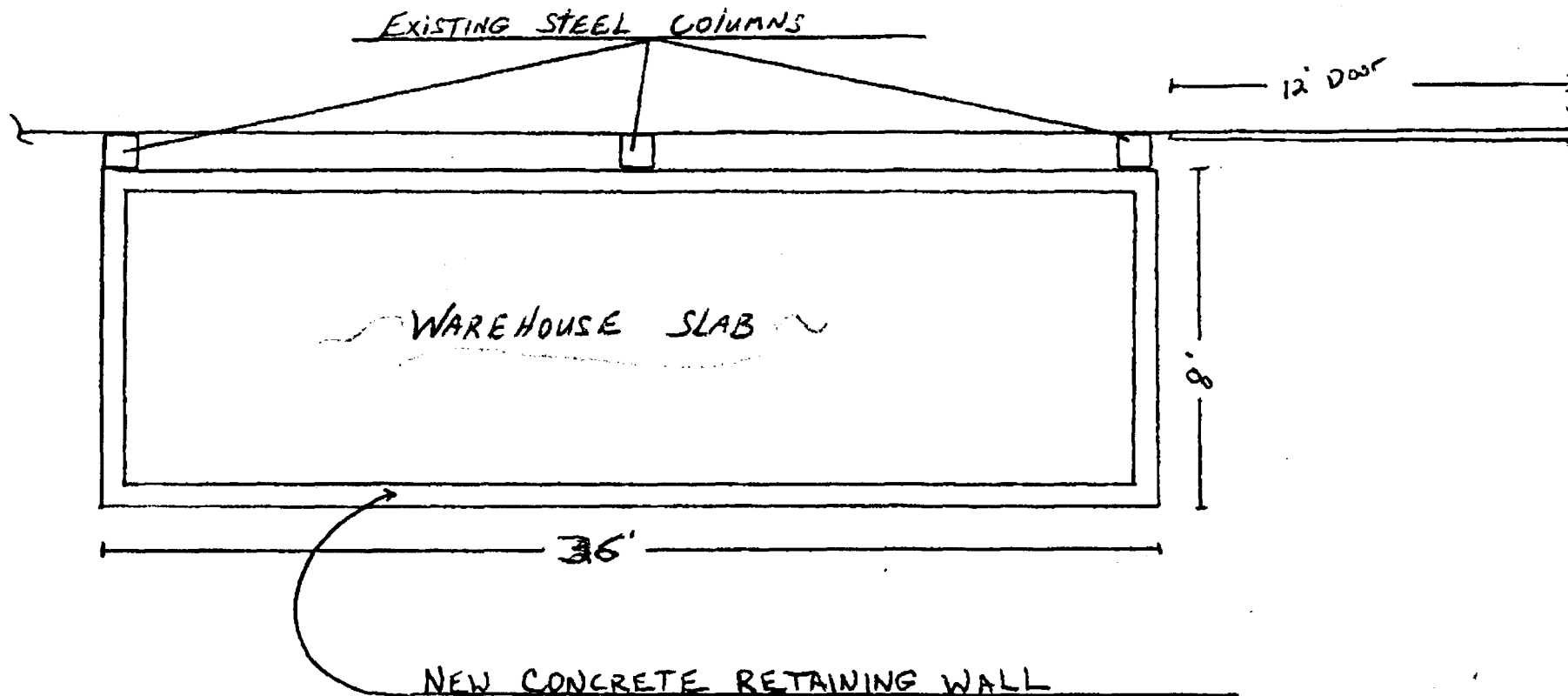

Job site: 825 1st AVE.

For : CONCERNANCY Oil CO.
OF GRAND Jct., INC.

Mgr. : FRANK PEABODY

Ph # 243-6934

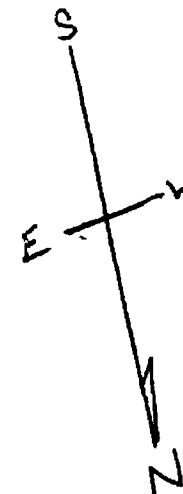

MAYS CONSTRUCTION
SPECIALTIES INC.
P.O. Box 4188
Grand Junction, CO 81502
303-243-5888

REV.
8/10/95

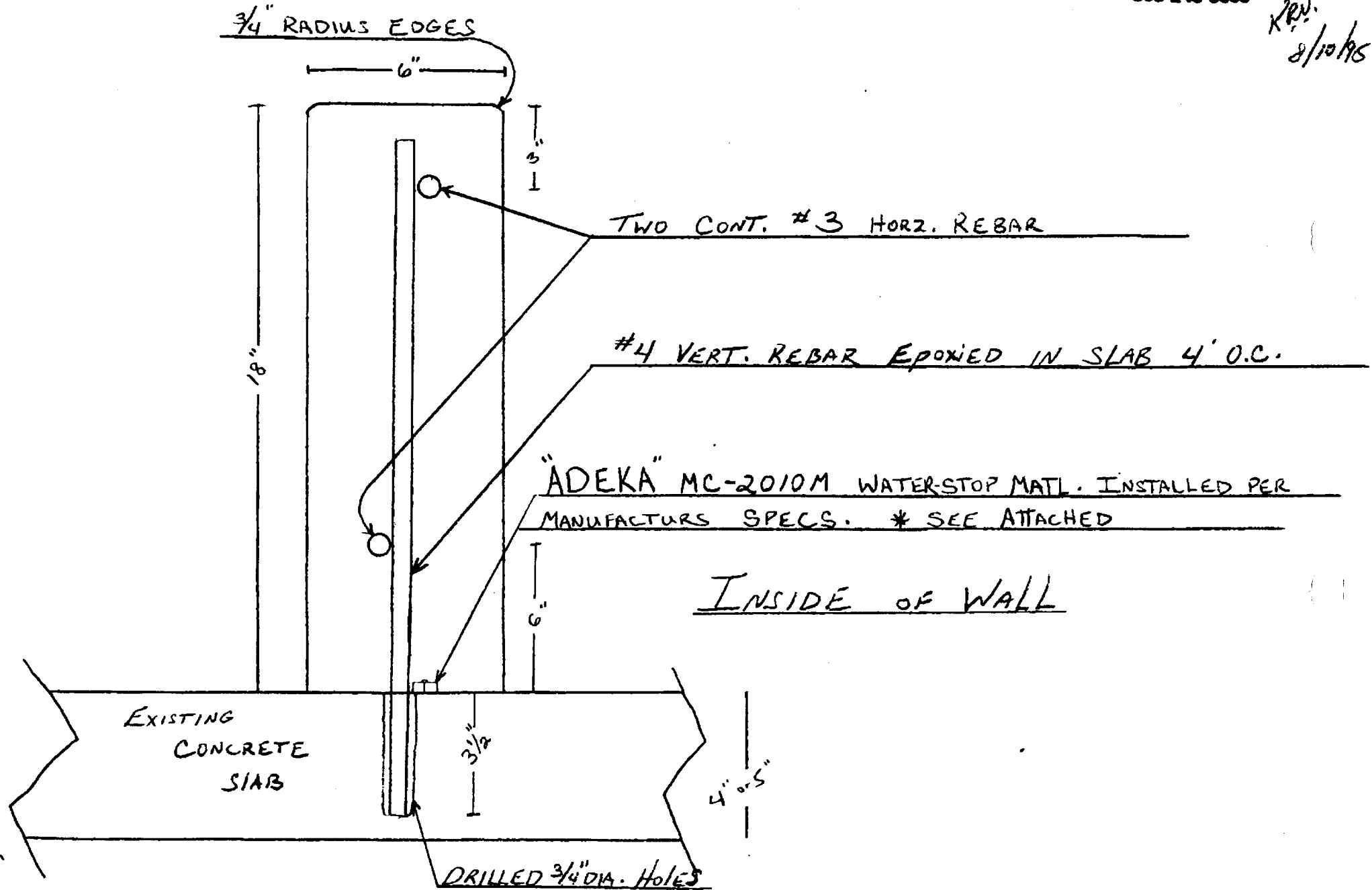

NOTES:

- TANK SHALL BE CONSTRUCTED IN ACCORDANCE WITH UNDERWRITERS LAB. INC. STANDARDS FOR UNDERGROUND STORAGE TANKS SUBJECT 58, LATEST REVISION U.L. LABEL APPLIED AS SHOWN.
- OUTSIDE-SANDBLAST (COMMERCIAL) AND COAT WITH COL TAR EPOXY (10 MIL SHELL, 15-MIL HEADS) FUTURA THANE - 527.
- ALL OPENINGS SHALL BE COVERED TO PREVENT ENTRANCE OF DIRT AND MOISTURE DURING SHIPMENT.
- LEAK TEST AT MORE THAN 5 P.S.I. AND LESS THAN 7 P.S.I.
- TANK IS DESIGNED FOR ZERO PRESSURE OR ATMOSPHERIC CONDITION ONLY.

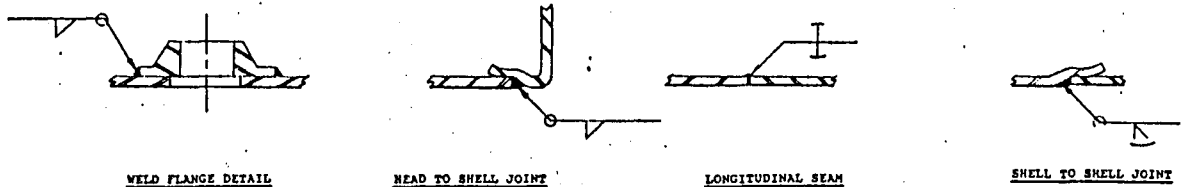
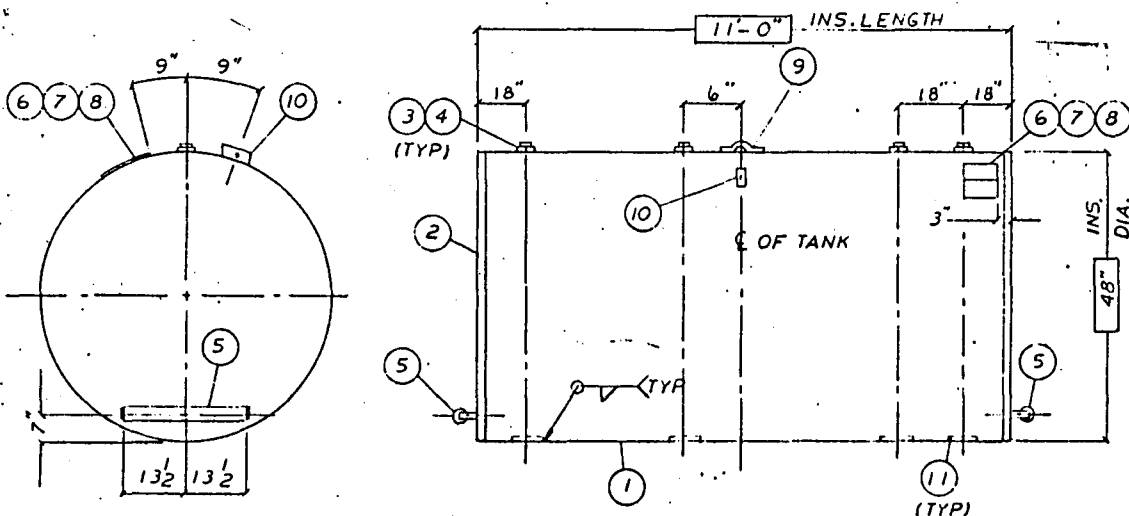

6/1/94



FINAL BILL OF MATERIAL

SHIP PC	MARK NO	ASSM PC	DESCRIPTION	LENGTH		MATERIAL SPEC	WEIGHT
				FT	IN		
1	1A		STI-P3 U.G.S.T.				
	1-1	1	.123 SHt. 60"	12	8		
	1-2	2	.123 SHt. 47 3/4 Dia. F.F. Head				
	1-3	4	5" Weld Flange				
	1-4	4	5" x 4" Nylon Bushing				
	1-5	2	5" Weld-On Zinc Anode				
	1-6	1	EMP Nameplate				
	1-7	1	Label Bracket				
	1-8	1	UL Label				
	1-9	1	L1-12 Lifting Loop				
	1-10	1	PP2 Clip				
	1-11	4	1/4 Plate 12"		12		
		4	Tin Cover				
			165 Sq.Ft. Futura Thane-527 (4 Gals)				
		1	STI-P3 Label Kit				
	1-12	1	.123 Sheet 72"	12	8		

MATERIAL LISTED IS FOR ONE TANK MATERIAL LISTED IS MINIMUM THICKNESS REQUIRED

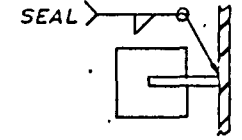

SHOP NOTE:

REMOVE PLASTIC WRAP FROM ANODE AFTER PAINTING.

ANODE DETAIL-ITEM NO. 5

NO	DATE	REVISIONS
A	5-18-92	Changed Shell Mat'l. from 2-66" wide sheet to 1-60" & 1-72" wide sheet.

CHECKER	PRINT	RECORD
APPROVAL		PAINT NOTE
FINAL APPROVAL		SHOP DATE

EATON EATON METAL PRODUCTS CO.
DENVER, COLORADO SALT LAKE CITY, UTAH

STI-P3 TANK
1,000 GALLON HORIZONTAL
48 DIA. 11 0' LONG BELOW GROUND TANK

DRN BY L.E.	DATE 3-1-90	SHOP NO.	REV
CHKD BY DE.K.			C-4638 A

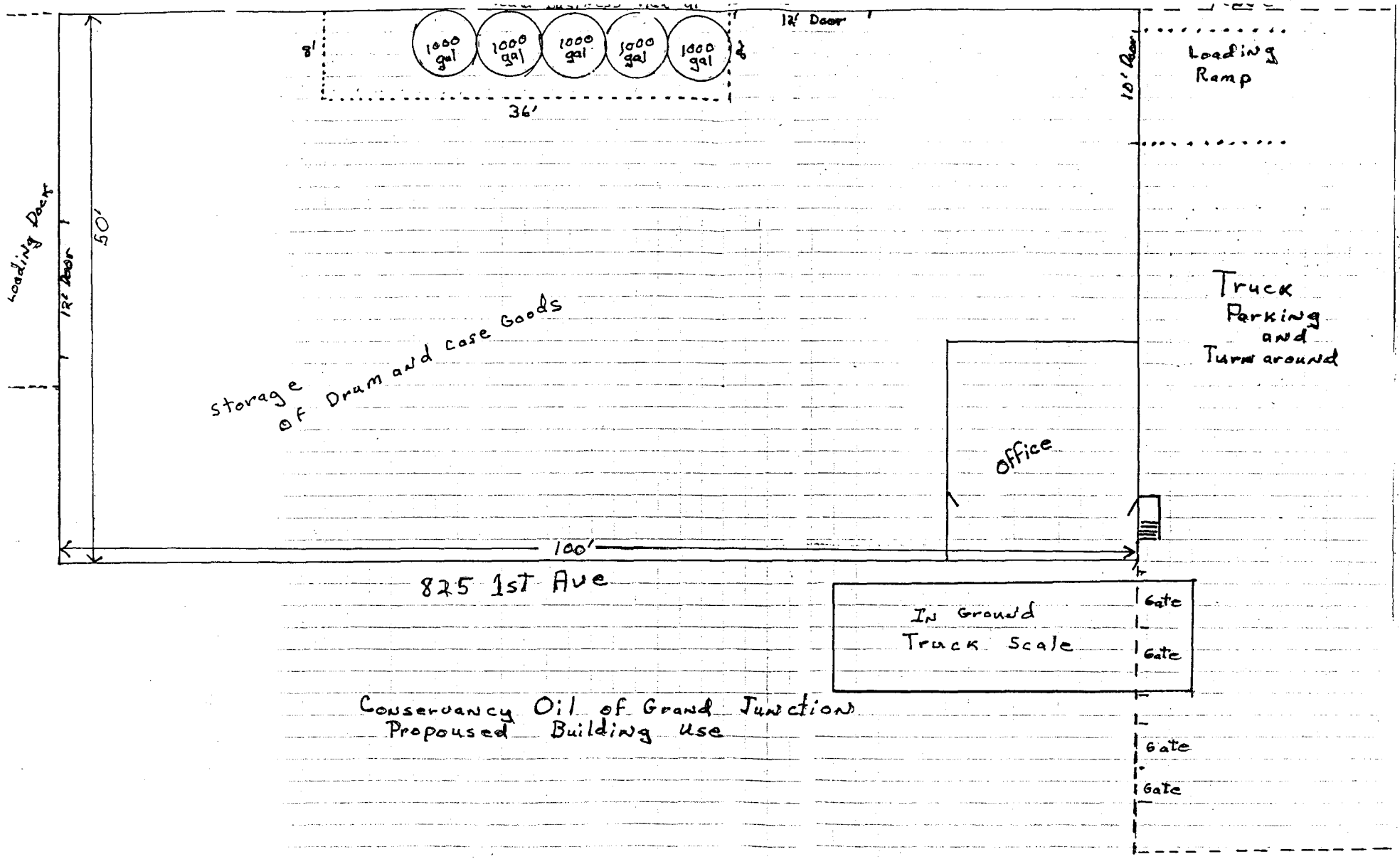

1st Ave

11" x 17"