

LEGEND

- ⊕ BLM SURVEY MONUMENT
- ⊙ FOUND #5 REBAR W/CAP LS#20632 (BANNER INC.)
- FOUND NAIL
- SET 60D NAIL
- ROAD RIGHT-OF-WAY
- BURIED ELECTRIC CABLE
- OVERHEAD POWER LINES
- BURIED CABLE TV
- GAS LINE
- WATER LINE
- SANITARY SEWER (DASHED WHERE APPROX.)
- STORM SEWER
- CHAIN LINK FENCE
- RAILROAD TRACKS
- ⊕ FIRE HYDRANT
- SDI STORM DRAIN
- WV WATER VALVE
- MH MAN HOLE
- PO POWER POLE
- VAULT SAN SEWER LIFT STATION
- PEDESTAL TELEPHONE PEDESTAL
- EP ELECTRIC PANEL
- GW GUY WIRE
- CONCRETE REPLACEMENT
- ASPHALT REPLACEMENT

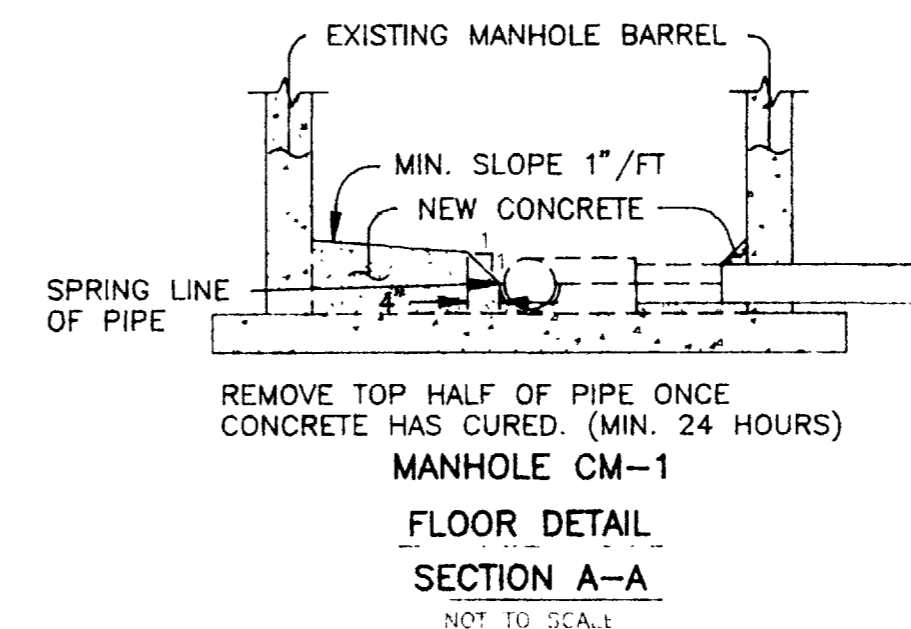
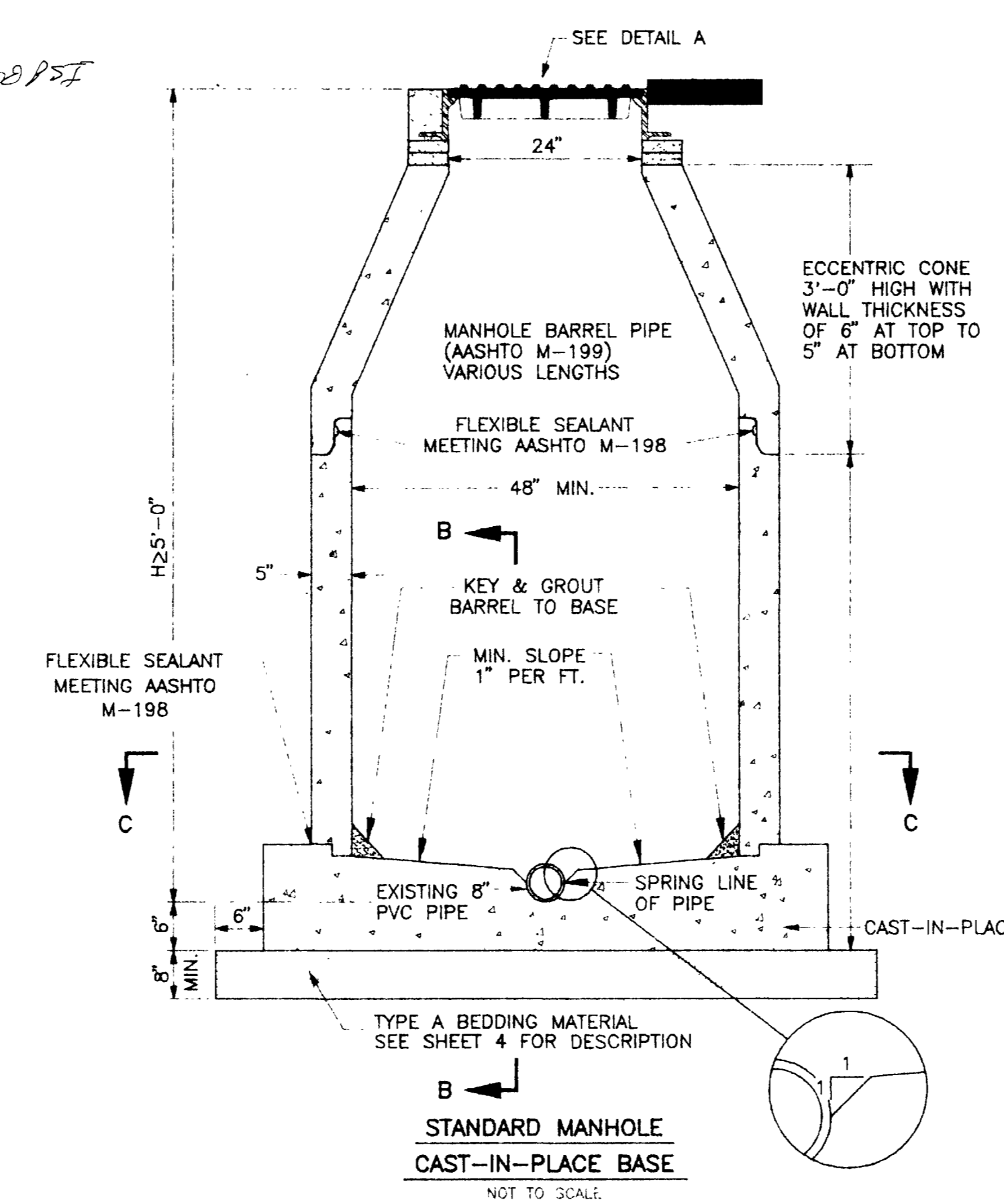
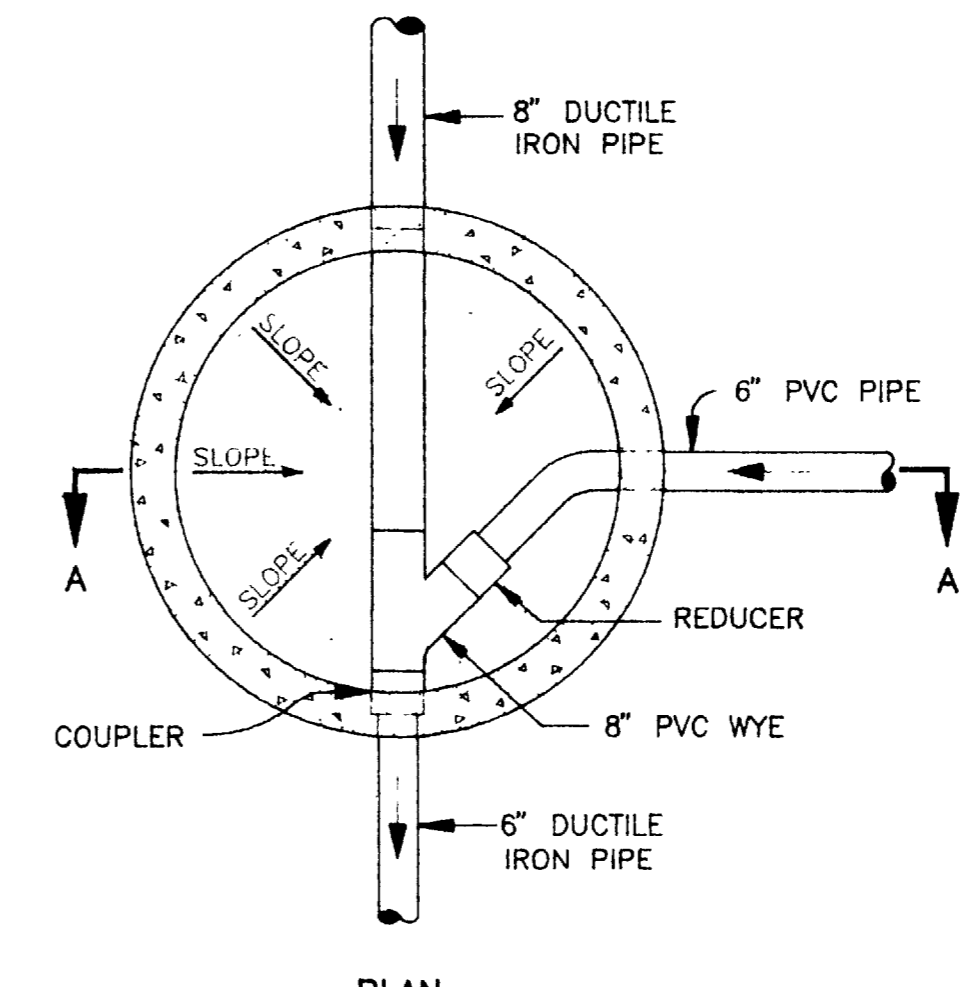
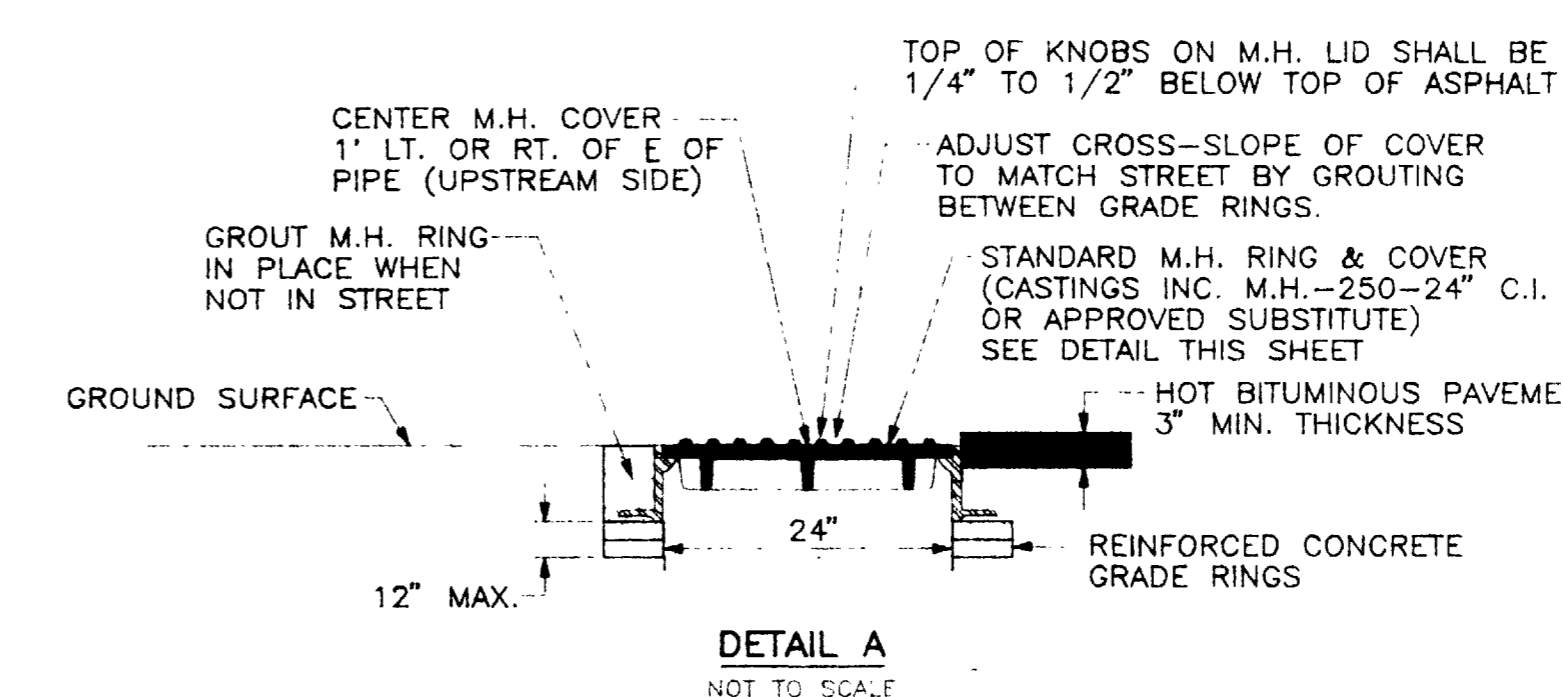
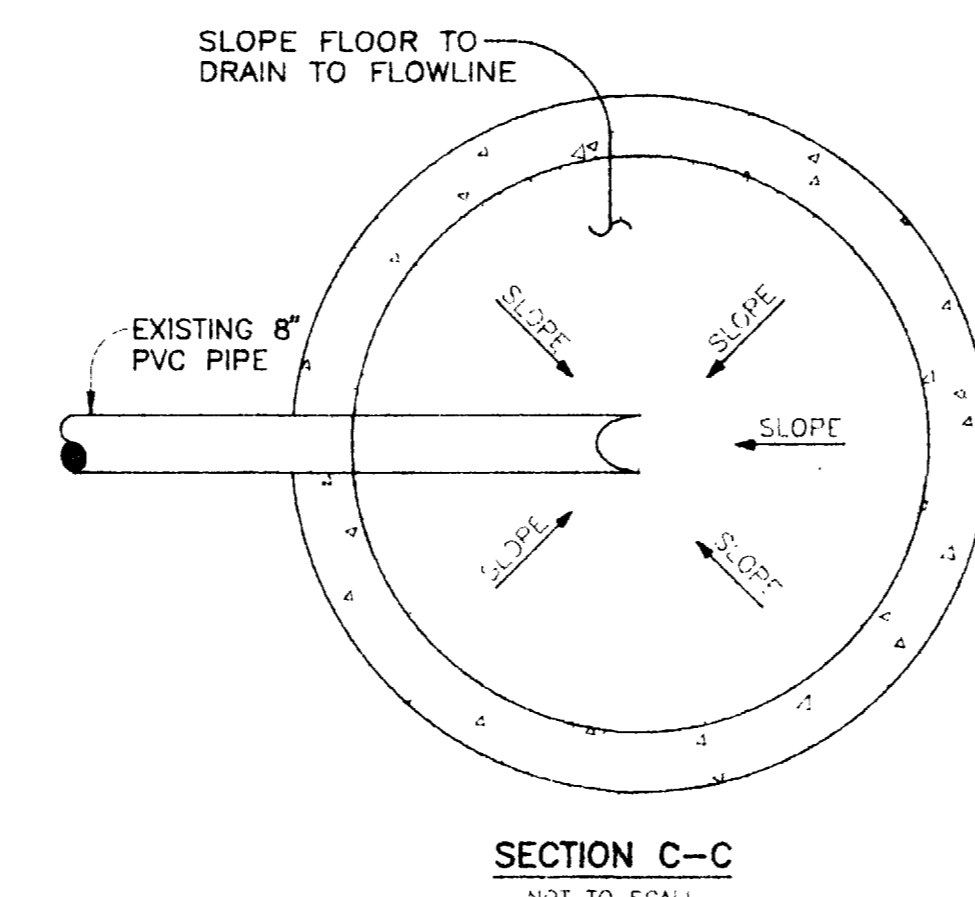
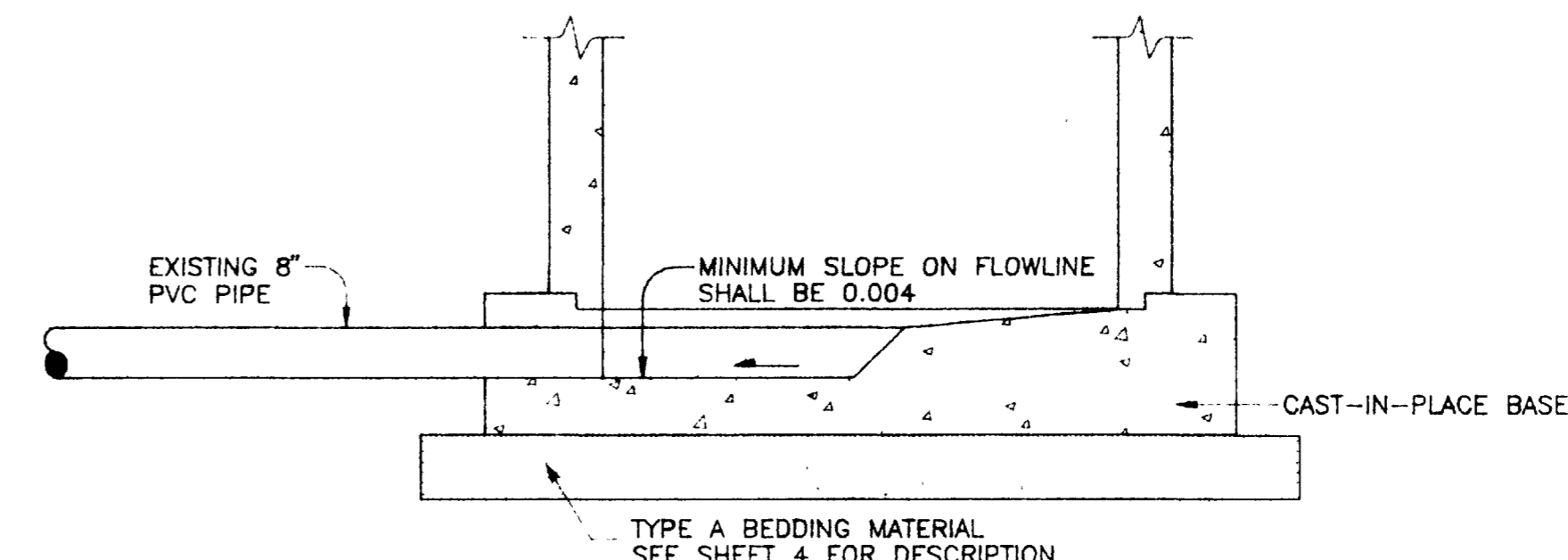

COORDINATE LIST

FEATURE	NORTHING	EASTING	ELEVATION
BLM SURVEY CAP	5000.00	5000.00	4549.44
CP1	4977.24	4961.35	4547.40
CP2	4084.93	5000.71	4541.69
CP3	4036.57	4961.39	4542.05
STA 0+00	4052.64	4830.20	*
STA 0+07.22	4053.11	4830.20	*
STA 0+58.90	4104.80	4830.20	*
STA 1+51.05	4104.87	4922.34	*
STA 2+08.08	4145.20	4962.67	*
STA 5+61.13	4498.25	4962.40	*
STA 5+71.41	4505.52	4955.13	*
STA 5+78.16	4512.27	4955.13	*

* SEE PLAN & PROFILE, SHEET 3, FOR PIPE INVERT ELEVATION

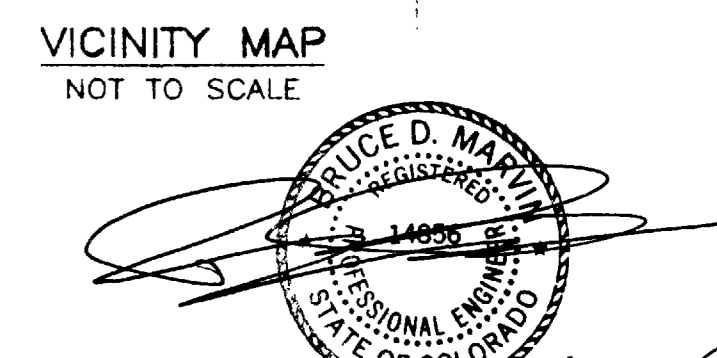
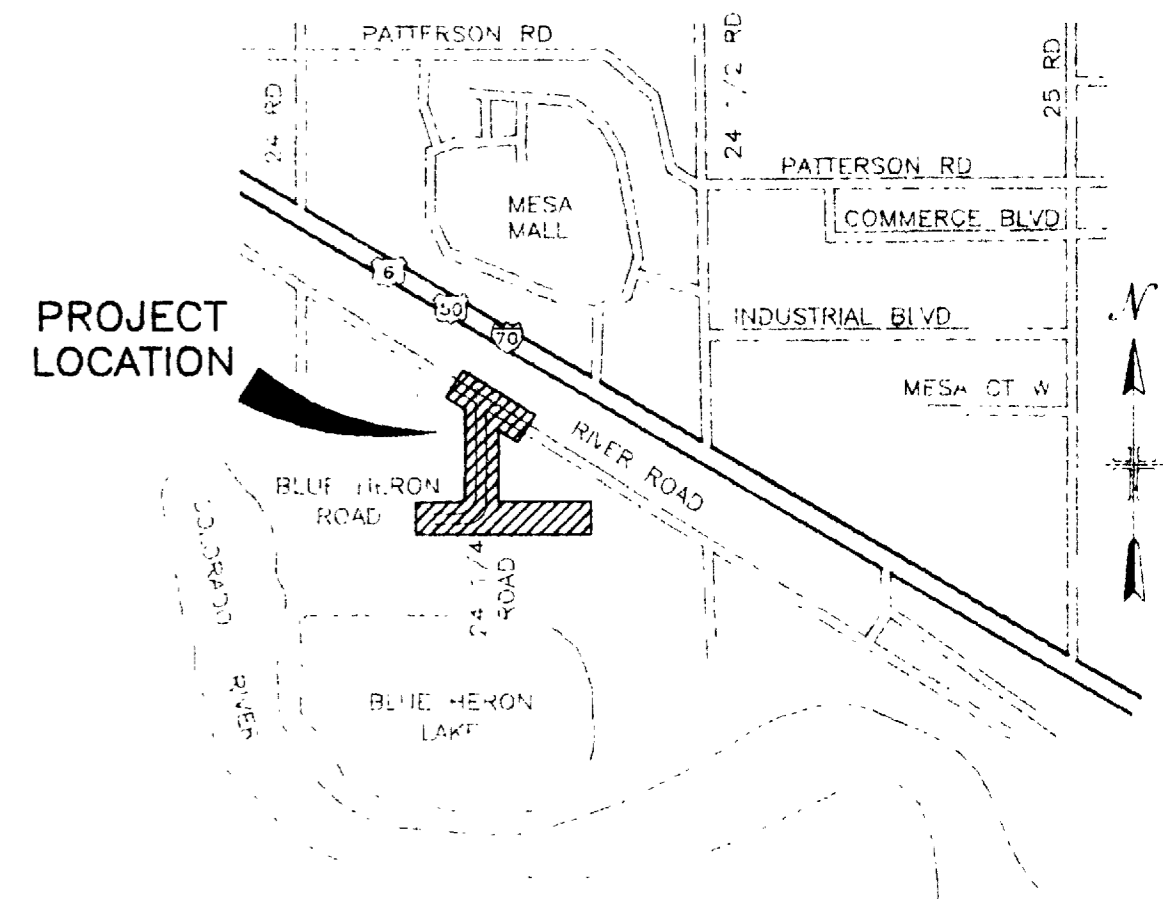

SHEET 1 OF 4

WESTERN CONSULTING ENGINEERS & LAND SURVEYORS
ENGINEERS, INC. 2150 Hwy 9 & S. Grand Junction, CO 81502-9222

PROJECT MAP

BLUE HERON ROAD LIFT STATION AND 6" PVC FORCE MAIN GRAND JUNCTION, COLORADO

MESA COUNTY, COLORADO

DESIGN	G.L.L.	DRAWN	K.M.S.	CHECKED	G.L.L.
DATE	2-17-95	WET DWG. NO.	3690-0326-28		

CITY OF GRAND JUNCTION
APPROVED FOR CONSTRUCTION BY:

Bill Cheney, Utility Eng. 60795

TITLE _____ DATE _____

TITLE _____ DATE _____

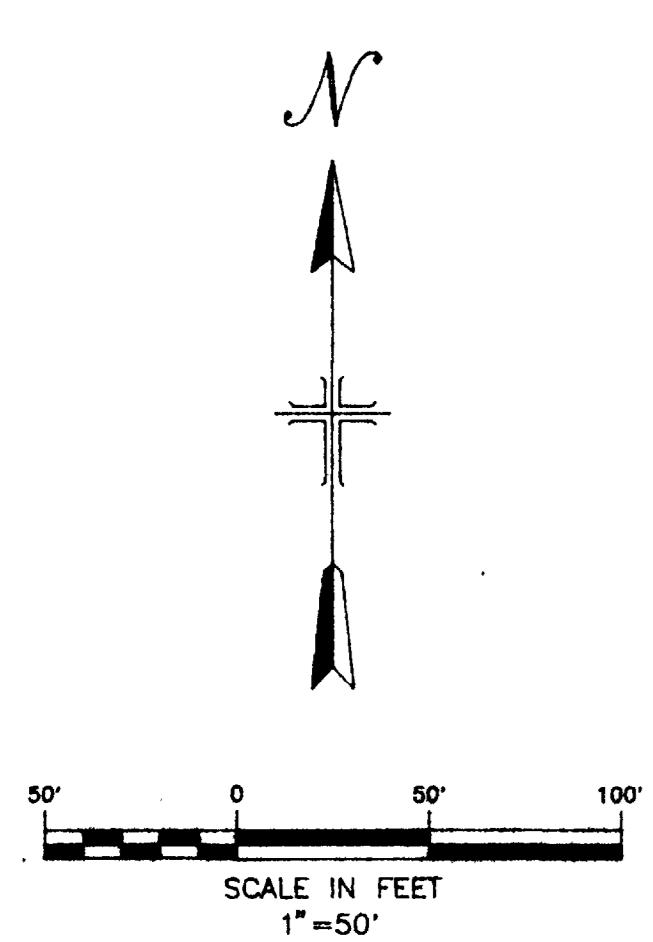
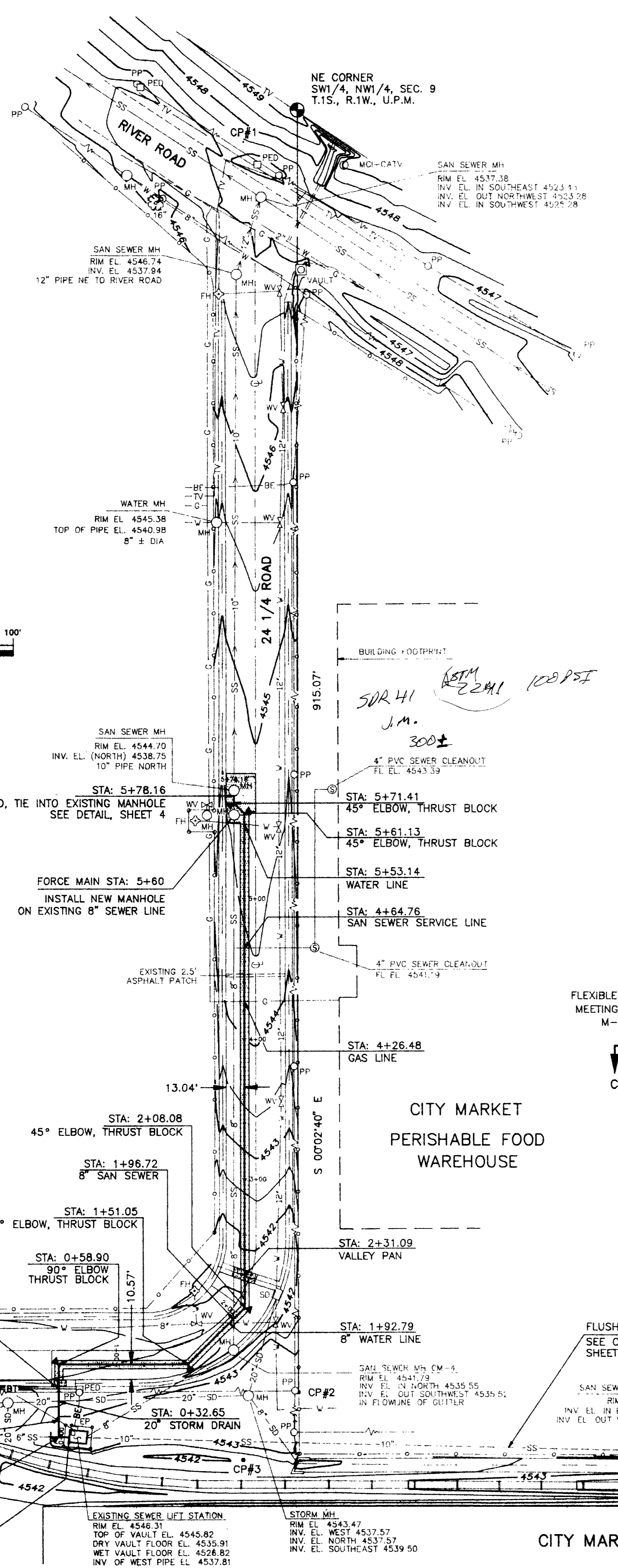

BLUE HERON INDUSTRIAL PARK

CITY MARKET PERISHABLE FOOD WAREHOUSE

CITY MARKET GROCERY WAREHOUSE

BLUE HERON ROAD

STORM MH
RIM EL. 4543.49
INV. EL. IN WEST 4535.39
INV. EL. IN EAST 4534.89
INV. EL. OUT SOUTH 4534.79

STA: 0+18.82
8" SAN SEWER

STA: 0+07.22
TIE INTO EXIST. 6" SS THRUST BLOCK

STA: 0+00.00
FL EXIST. 6" SS

EXISTING SEWER LIFT STATION
RIM EL. 4546.31
TOP OF VAULT EL. 4545.82
DRY VAULT FLOOR EL. 4535.91
WET VAULT FLOOR EL. 4528.82
INV. OF WEST PIPE EL. 4537.81

STORM MH
RIM EL. 4543.47
INV. EL. WEST 4537.57
INV. EL. NORTH 4537.57
INV. EL. SOUTHEAST 4539.50

FLUSH THIS SECTION OF LINE CLEAN
SEE CONSTRUCTION NOTE 20,
SHEET 2

SAN SEWER MH CM-3
RIM EL. 4543.61
INV. EL. IN NORTH 4535.55
INV. EL. IN EAST 4535.76
INV. EL. OUT WEST 4535.76

SAN SEWER MH CM-2
RIM EL. 4545.03
TOP OF 8" PIPE EL. 4537.52

SAN SEWER MH CM-1
RIM EL. 4544.92
INV. EL. 4538.17
INSTALL NEW BASE, SEE DETAIL THIS SHEET
SEE CONSTRUCTION NOTE 11, SHEET 2.

SAN SEWER MH
RIM EL. 4546.39
BOTTOM EL. 4539.87

ELEC. MH
RIM EL. 4544.78
EMP-1

6" PVC FORCE MAIN FROM CITY MARKET TRUCK WASH

SDR 41
J.M.
300±
108 PFT

4" PVC SEWER CLEANOUT
FL EL. 4543.33

STA: 5+71.41
45° ELBOW, THRUST BLOCK

STA: 5+61.13
45° ELBOW, THRUST BLOCK

STA: 5+53.14
WATER LINE

STA: 4+64.76
SAN SEWER SERVICE LINE

4" PVC SEWER CLEANOUT
FL EL. 4541.79

STA: 4+26.48
GAS LINE

STA: 2+08.08
45° ELBOW, THRUST BLOCK

STA: 1+96.72
8" SAN SEWER

STA: 1+51.05
45° ELBOW, THRUST BLOCK

STA: 0+41.82
BURIED TELE.

STA: 0+58.90
90° ELBOW THRUST BLOCK

STA: 2+31.09
VALLEY PAN

STA: 1+92.79
8" WATER LINE

SAN SEWER MH CM-4
RIM EL. 4547.79
INV. EL. IN NORTH 4535.55
INV. EL. IN EAST 4535.55
INV. EL. OUT WEST 4535.55

CP#2

STA: 0+32.65
20" STORM DRAIN

CP#3

NE CORNER SW 1/4, NW 1/4, SEC. 9 T.1S., R.1W., U.P.M.

24 1/4 ROAD

RIVER ROAD

915.07'

13.04'

S 00°02'40" E

10.57'

10.57'

10.57'

10.57'

10.57'

10.57'

10.57'

10.57'

10.57'

10.57'

10.57'

10.57'

10.57'

10.57'

10.57'

10.57'

10.57'

10.57'

10.57'

10.57'

10.57'

10.57'

10.57'

10.57'

10.57'

10.57'

10.57'

10.57'

10.57'

10.57'

10.57'

10.57'

10.57'

10.57'

10.57'

10.57'

10.57'

10.57'

10.57'

10.57'

10.57'

10.57'

10.57'

10.57'

10.57'

10.57'

10.57'

10.57'

10.57'

10.57'

10.57'

10.57'

CONSTRUCTION NOTES:

- 1) The Contractor will secure and pay for all permits required for the prosecution of the Work under this Contract. A permit for construction and installation of facilities in public right-of-way will be required by City of Grand Junction, Department of Public Works, Engineering Division. Costs associated with permits will be considered incidental, and will be considered to be included within costs listed in the Bid.
- 2) The Contractor shall be responsible for initiating, maintaining and supervising all safety precautions and programs in connection with the work. He shall take all necessary protection to prevent damage, injury or loss to:
 - (a) All employees on the Work and other persons who may be affected thereby,
 - (b) All work and all materials or equipment to be incorporated therein whether in storage on or off site, and
 - (c) Other property at the site or adjacent thereto, including trees, shrubs, lawns, walks, pavements, roadways, structures and utilities not designated for removal, relocation or replacement in the course of construction.

The Contractor shall comply with all applicable laws, ordinances, rules, regulations and orders of any public body having jurisdiction for the safety of persons or property or to protect them from damage, injury or loss. The Contractor shall erect and maintain, as required by the conditions and progress of the work, all necessary safeguards for safety and protection.
- 3) Excavations shall adhere to the lines and grades as shown on the construction plans or as modified by the Engineer in the field. The excavation operations shall adhere to all Federal, State, and local safety regulations that are applicable. The inspection of the Work by the Engineer does not relieve the contractor from any violations of safety regulations. The Contractor shall be familiar with the current rules and regulations governing excavation work as set out by the Industrial Commission of Colorado and OSHA.
- 4) No public street, alley or roadway shall be intentionally closed, blocked or obstructed without first obtaining permission from the proper authorities having jurisdiction over the affected right-of-way. Prior to closing any roadway or traffic lane, the Contractor shall set up and maintain proper traffic control in accordance with an approved traffic control plan (TCP). A TCP is a plan for guiding traffic safely through or around a construction work zone or other obstruction. The TCP must provide safe methods for movement of pedestrians and motorists who travel through the work zone, and a safe area for all persons and equipment working within the roadway. The Contractor should consider subcontracting the traffic control work to a qualified company that provides such services. Should the Contractor decide to rent equipment and do the traffic control work himself, he shall designate a Traffic Control Supervisor (TCS) who will be responsible for the setup, maintenance and removal of all traffic control devices. This supervisor shall be certified by the American Traffic Safety Services Association (ATSSA). The TCS shall have in possession at all times a copy of the Manual on Uniform Traffic Control Devices (MUTCD) or a copy of the ATSSA Guide for Work Area Traffic Control. In any case, no work shall be done until all advance warning signs and traffic control devices are in place. The contractor shall notify all appropriate emergency agencies of any closures or expected delays. Copies of all TCP shall be provided to the City of Grand Junction, Department of Public Works, Engineering Division. The Engineer or Inspector shall have the authority to require the Contractor to provide additional signs or barricades for those locations he deems to be inadequate. At times, it may be necessary for the Contractor to provide flaggers to direct traffic. All flaggers provided by the Contractor shall be certified by the Colorado Department of Transportation or ATSSA and shall be wearing the proper safety attire while performing the duties of a flagger.
- 5) Cutting of existing asphalt shall be accomplished so as to provide a neat even line perpendicular to and along the centerline of the roadway. The width of asphalt cut shall be a minimum of 6 feet, except as noted around manholes. Apply primer coat (MC-70 or the equivalent) over base course at a rate of 0.15 to 0.30 gallon per square yard. Apply tack coat to contact surfaces of curb, gutters and previously constructed asphalt. Apply primer and tack coat in accordance with manufacturer specifications. Hot Bituminous Pavement (HBP) Mix Grade C as defined by the Department of Highways, State of Colorado, Standard Specifications for Road and Bridge Construction, latest edition shall be used for patching and asphalt replacement. Any existing pavement not designated for removal which is damaged by construction shall be replaced in-kind by contractor at his expense. Thickness layer of patching shall not be less than 3 inches. HBP shall be compacted to 95 percent of Marshall Density. Existing asphalt removed as part of the construction requirements shall be removed off-site and disposed of in accordance with all applicable regulations.
- 6) Base course material shall conform to CDOT Class 6 specifications. The base course material shall be placed and compacted in 6 inch lifts to 95 percent Modified Proctor Density (ASTM D-1557).
- 7) All backfill material shall be placed with moisture-density control. Pipe haunching material shall be placed and compacted in 6 inch lifts to 90 percent Standard Proctor Density (ASTM D-698) around the pipe and to 6 inches above the pipe. The earth backfill material shall be placed full trench width in uniform layers not more than 6 inches thick. The backfill material between the pipe haunching and base course material shall be compacted to 95 percent Standard Proctor Density and shall be within two (2) percent of optimum moisture content. Compaction testing frequency shall be a minimum of one test per 100 lineal foot of trench or part thereof for every 2 vertical feet of material placed and a minimum vertical testing interval of mid trench depth and at finish grade. Copies of compaction tests results performed within the City of Grand Junction road right-of-way shall be furnished to the City of Grand Junction, Department of Public Works, Engineering Division.
- 8) The pipe shall be installed to grades and alignments indicated on the construction plans or as modified by the engineer in the field. The force main piping and fittings shall be PVC Pressure Rated Pipe, 100 psi or equal with rubber gasket joints meeting the requirements of ASTM D-2241 (SDR 41). The pipe shall be handled and installed according to manufacturer specifications. Placement and compaction of bedding and haunching, earth or pit run, D.D.O.T Class 6 and pavement shall comply with requirements stated on the construction plans or the permit for construction within the roadway. Compaction of material within road right-of-way shall comply with City of Grand Junction, Department of Public Works and Utilities, Engineering Division, standard specifications for construction of waterlines, sanitary sewer, storm drainage, and irrigation systems, detailed street construction specification and standard details. City of Grand Junction reserves the right to have an inspector on site at any time work is being performed within the right-of-way.
- 9) Prior to final connection of the new force main with the existing force main, the new force main shall be tested for pressure and leakage in accordance with City of Grand Junction specifications for pipeline testing and AWWA C-603, Section 4. The Contractor shall furnish all labor, water and other incidental items required to conduct the tests. Test results will not be considered valid without the presence of the Engineer or his representative throughout the test. No pressure tests will be performed until all thrust blocks have been placed and cured for

(CONTINUATION OF NOTE 9)

- at least seven (7) days, and the pipeline partially backfilled to prevent any movement or lifting of the pipe. Pavement or other permanent surfaces shall not be placed until all pressure and leakage tests are satisfactorily completed. The testing pressure shall be double the maximum operating pressure of 15 psi or a resultant test pressure of 30 psi.
- 10) At least 7 days prior to shutting off the lift station pumps, the Contractor shall submit to the Engineer, for approval, a written plan indicating the provisions planned to minimize the pump down time and any provision for temporary bypass pumping. The pumps shall not be turned off until this plan has been approved by the Engineer. Coors Parcel and City Market must be notified 24 hours in advance of shutting off the lift station pumps so the facilities can make arrangements to decrease their flows. The pumps shall be turned off only between the hours of 8:00 P.M. and 4:00 A.M. and only at the end of a pumping cycle. Unless provisions are made for temporary bypass pumping of the lift station, the construction sequence shall be scheduled such that the pumps are turned off for the minimum time interval necessary and in no case, long enough for the liquid level to come within one foot of the dry vault floor. It is estimated that the time between turning off of the pumps at the end of a pump cycle and when the liquid level rises to within one foot of the dry vault floor will be between 30 and 45 minutes. The bid costs shall include the cost of any bypass pumping and other costs associated with maintaining continuous sewer service for the Coors and City Market facilities. Any damage or contamination which results from the pumps being off for a longer period of time than allowed herein shall be repaired and cleaned up to original condition by and at the cost of the contractor. Once the pumps have been shut off, the existing 6 inch force main shall be drained prior to completing any in-line connections. A fitting which utilizes a valve, such as a 2 inch corporation stop, shall be inserted into the existing force main at approximately the spring line of the pipe to allow removal of wastewater. A vacuum truck shall be utilized to remove as much wastewater as possible through the corporation stop. Adapters shall be utilized to connect the corporation stop with the suction line to prevent spillage of wastewater onto the ground. The valve shall be closed once wastewater has been removed, and an opening in the top of the pipe of sufficient size to allow the hose from the vacuum truck to be inserted into the pipe and remove the remaining wastewater. An alternate means of wastewater removal from the force main may be utilized with the prior approval of the Engineer. Contamination of surrounding ground with wastewater must be minimal. Once the wastewater has been removed as much as practical, the existing force main may be cut and the new fittings installed. The section of pipe removed from service must be abandoned, see Note 13.
- 11) Manhole CM-1, located within City Market's private driveway, will require modifications to the existing base to allow any surcharge wastewater to drain into the main pipe. Additional concrete shall be placed within the bottom of the existing manhole and sloped to drain into the flow line as shown on the construction plans. Prior to placement of the concrete, modifications to the existing sewer line must be performed to prevent wastewater from contacting the new concrete during the initial curing period. There are two openings in the sewer line which will require repair before concrete placement. The first opening, approximately a 4 inch diameter hole which has been drilled in the top of a 6 inch PVC service line, is to be repaired by cutting a patch large enough to completely cover the opening from a piece of 6 inch PVC pipe and installed over the opening and secured by an approved PVC glue and a metal band. The second opening is the top portion of the existing 8 inch pvc wye which has been removed. The wye has been adapted to ductile iron pipe on both ends. Repair to this opening may be performed by one of two procedures: 1) The preferable method is for the existing wye to be removed and replaced with a new 8 inch wye which must be reconnected to the ductile iron pipe and the 6 inch service line. By replacing the 6 inch wye, additional fittings may be required to connect all piping. These fittings may include but not limited to an 8 inch by 6 inch PVC reducer and short sections of 8 inch and 6 inch PVC pipe. All fittings shall be secured by appropriate glues and fasteners. 2) Cut the top off of a new wye large enough to completely cover the opening and secure the piece to the existing wye by an approved PVC glue and metal bands. It is believed replacement of the wye will produce the best results. An alternate means of containing wastewater within the main pipe will be allowed with the approval of the Engineer. Remove excess water and/or debris which may have collected in the manhole. Clean water under high pressure, shall be utilized to remove as much scum or coatings as possible from the existing concrete and pipe. Once repairs to the existing pipe have been satisfactorily completed and the surfaces which will come into contact with the new concrete cleared, the concrete shall be placed according to the construction plans. The top of the pipe within the manhole must be removed once the concrete has cured for a min of 24 hours.
- 12) A new manhole must be installed on the existing 8" sewer line in 24' +/- Road. The location of this manhole is indicated on sheets 1 and 3 of the construction drawings. The purpose of this manhole is to serve as a terminal manhole on the existing sewer line. All existing 8" pvc pipe (estimated to be 18') between the new manhole and the existing manhole located to the north, shall be removed and properly disposed of. The new manhole shall be constructed to allow water collection to discharge into the sewer line.
- 13) The existing force main shall be abandoned at the lift station and the treatment plant. Each end of the pipe shall be filled with grout to a distance of five (5) feet from the end of the pipe. The end of the pipe shall then be capped with concrete. A detail for sewer pipe abandoning is shown in the construction plans, sheet 4.
- 14) Once the new force main has satisfied installation and testing requirements and the tie-in to the existing lift station has been completed, the package treatment plant must be inactivated. This will involve abandoning the inflow pipe, described in Note 13, and removal of approximately 83,000 gallons of untreated wastewater from the various tanks. Removal of the wastewater shall be accomplished by utilizing a vacuum truck to remove the waste and transporting it to Persigo Wastewater Treatment Plant for disposal. Persigo must be notified in advance to dispose of the wastewater. The sides and bottom of the individual tanks shall be high pressure sprayed with clean water to aid in the removal of scum or deposits. To provide access to the tanks for removal of waste water, a portion of the existing chain link fence may be temporarily taken down without cutting the mesh. Upon completion of waste water removal from the tanks, the fence must be restored to its original condition by repairing or replacing the fence post and restoring the fence. Removing wastewater from the tanks shall be performed in such a manner so as to prevent damage to the existing lab building, the fence, or other existing facilities. Any such damage shall be repaired and/or replaced by and at the expense of the contractor. The treatment plant discharge pipe shall be plugged and capped in accordance with the sewer pipe abandoning detail shown on the drawings. The bid price shall include all costs associated with decommissioning the treatment plant including, but not limited to pumping, transportation and disposal of waste, waste disposal fees, cleaning the tanks, removing and replacing/repairing existing fence, capping the discharge pipe, etc. Salvaging of equipment and tanks will be performed by Coors.

15) (THIS NOTE NOT USED)

- 16) The existing wet well has approximately 8 inches of sediment which has been deposited in the bottom of the well, and must be removed. Removal will require the use of a vacuum truck. The bid shall include the cost of removing this sediment. The wet well shall be cleaned only after the section of line from manhole CM-3 to the lift station has been cleaned.
- 17) Inspectors will be assigned by the owner as his authorized representative to inspect all materials used and all Work done under the Contract. The inspector is assigned to the Work to observe the progress of the Work and the manner in which it is being done and to call the attention of the Contractor to any deviations from the requirements of the contract requirements. The inspector will not act as a foreman for the Contractor. The inspector will have full authority to reject defective materials and Work. The Engineer and inspectors shall at all times have the right and access to inspect the Work and materials. The Contractor shall furnish all reasonable aid and assistance required by the Engineer or Inspectors for the proper examination of the Work and all parts thereof. No Work shall be done or materials used without suitable inspections by the Engineer or Inspector, and no Work shall be covered up or backfilled without the approval or consent of the Engineer or Inspector after inspections are completed. The Contractor shall regard and obey the directions and instructions of the Engineer and Inspectors when the same are consistent with the Contract; provided, however, that should the Contractor object to any order give by an Inspector, the Contractor may make an appeal to the Engineer. Observations, inspections, and tests by the Engineer, inspector, or others are for the express purpose of providing quality assurance. Such activities shall not relieve the Contractor from his obligations to perform the Work in accordance with the requirements of the Contract.
- 18) The proposed force main will cross an existing gas line (station 4+26.48) and an existing sewer service line (station 4+14.76), the exact elevations of which are unknown but are critical for determination of final grades. Prior to installing any portion of the force main, the elevations of these two lines at their intersection with the proposed force main alignment shall be determined by temporarily exposing them. The holes shall subsequently be filled to grade to provide a smooth, level traffic surface. Backfill shall satisfy the compaction requirements for trench backfill. The profile of the proposed force main will be adjusted based on the determined elevations of these two lines. The bid shall include the cost of pot-holing and backfilling in these two locations.
- 19) The contractor shall include in his bid price, the cost of resetting the lift station pump limit switch elevations to those shown on the drawings.
- 20) The contractor shall include in his bid the cost of flushing the existing sewer line from manhole CM-3 to the lift station as shown on the drawings. The contractor is cautioned that, based on experience with flushing other sections of the existing line, the line may contain large gravel and rock fragments. Either the flushing must be performed in a manner so as to prevent debris from being flushed into the lift station, or all sediment and debris including large gravel and rock fragments, must be removed from the lift station after flushing the line. Flushing shall continue until all debris has been removed and the line is free and clear.
- 21) The contractor is cautioned that manholes and the lift station wet and dry vaults are confined spaces and appropriate safety precautions must be provided for all workers entering them.
- 22) Concrete shall be Colorado Division of Highways Class "B" (Section 601.02).
- 23) All cement used in mortar, concrete bases, grade finish, riser sections, cones, and flat tops, for sanitary sewer manholes, shall be Type V or modified Type II portland cement with less than 5% tricalcium aluminate.
- 24) Manhole riser sections, cones, flat tops, and grade rings shall be precast reinforced concrete conforming to ASTM C-478 or AASHTO M-199.
- 25) Backfill around manholes and other structures shall be placed in 8" max lifts and compacted to 95% AASHTO T-99.
- 26) All work shall be in accordance with approved plans and City or County specifications.
- 27) Manhole cone and flat top portions shall be positioned such that the manhole ring and cover is centered over the upstream flow line.
- 28) If the manhole sections are furnished with steps, they shall be installed in vertical alignment 1.0' Left or right of the ring and cover.
- 29) Initial construction survey will be provided by the Owner. Any construction stakes which have been removed or destroyed either by construction activities or through no fault of the Owner shall be replaced at the expense of the Contractor.

CITY OF GRAND JUNCTION
APPROVED FOR CONSTRUCTION BY:

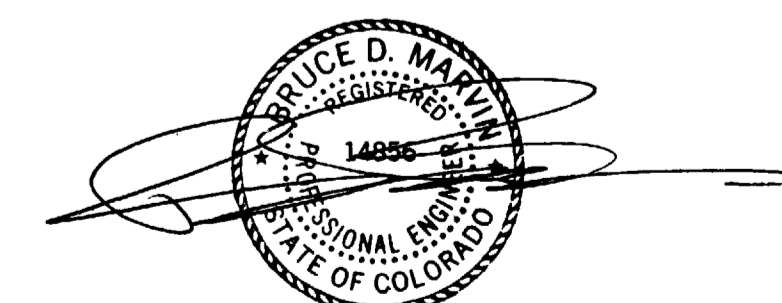

5-31-95
SHEET 2 OF 4

WESTERN ENGINEERS, INC. CONSULTING ENGINEERS / LAND SURVEYORS
2150 Hwy 8 & S1, Grand Junction, CO (970)248-3202

CONSTRUCTION NOTES

BLUE HERON ROAD LIFT STATION AND 6" PVC FORCE MAIN
GRAND JUNCTION, COLORADO

MESA COUNTY, COLORADO

DESIGN	G.L.L.	DRAWN	K.M.S.	CHECKED	G.L.L.
DATE	2-17-95	WEI DWG. NO.	3690-326	28	

REVISED: 5-30-95

SMITH
11/5/95

VALLEY PAN/GUTTER REPLACEMENT DETAILS

MAP LEGEND

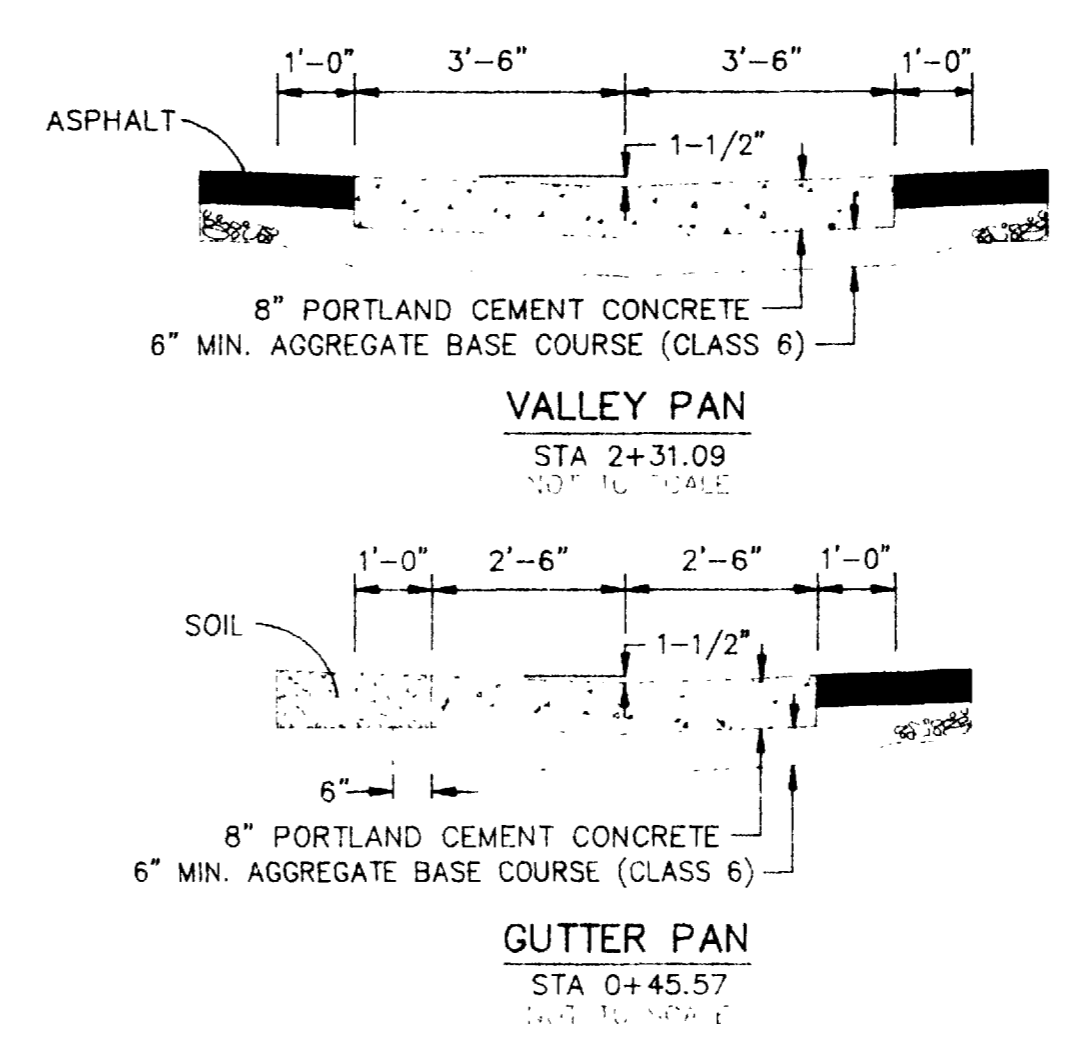

- CP#3 SURVEY CONTROL POINT
- BE BURIED ELECTRIC LINE
- GL GAS LINE
- WL WATER LINE
- SS SANITARY SEWER (DASHED WHERE APPROX.)
- SD STORM DRAINAGE
- OL OVERHEAD POWER LINES
- CL CHAIN LINK FENCE
- FH FIRE HYDRANT
- SC SAN SEWER CLEANOUT
- SG STORM GRATE
- WV WATER VALVE
- MH MAN HOLE
- PP POWER POLE
- PE TELEPHONE PEDESTAL
- EP ELECTRIC PANEL
- GW GUY WIRE
- TL THRUST BLOCK LOCATION
- DH DRILL HOLE
- AR ASPHALT REPLACEMENT
- CR CONCRETE REPLACEMENT

DRILL LOG KEY

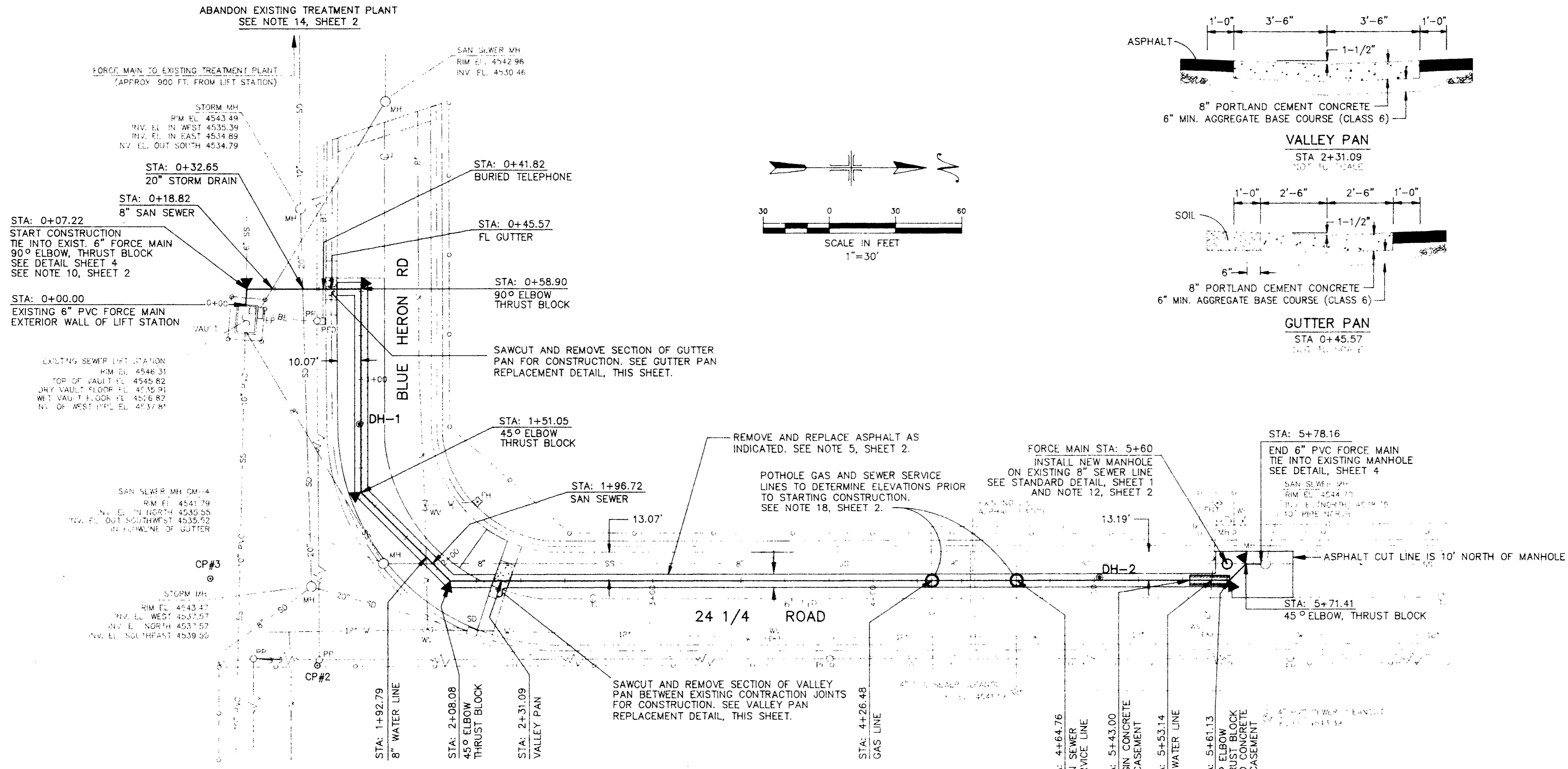
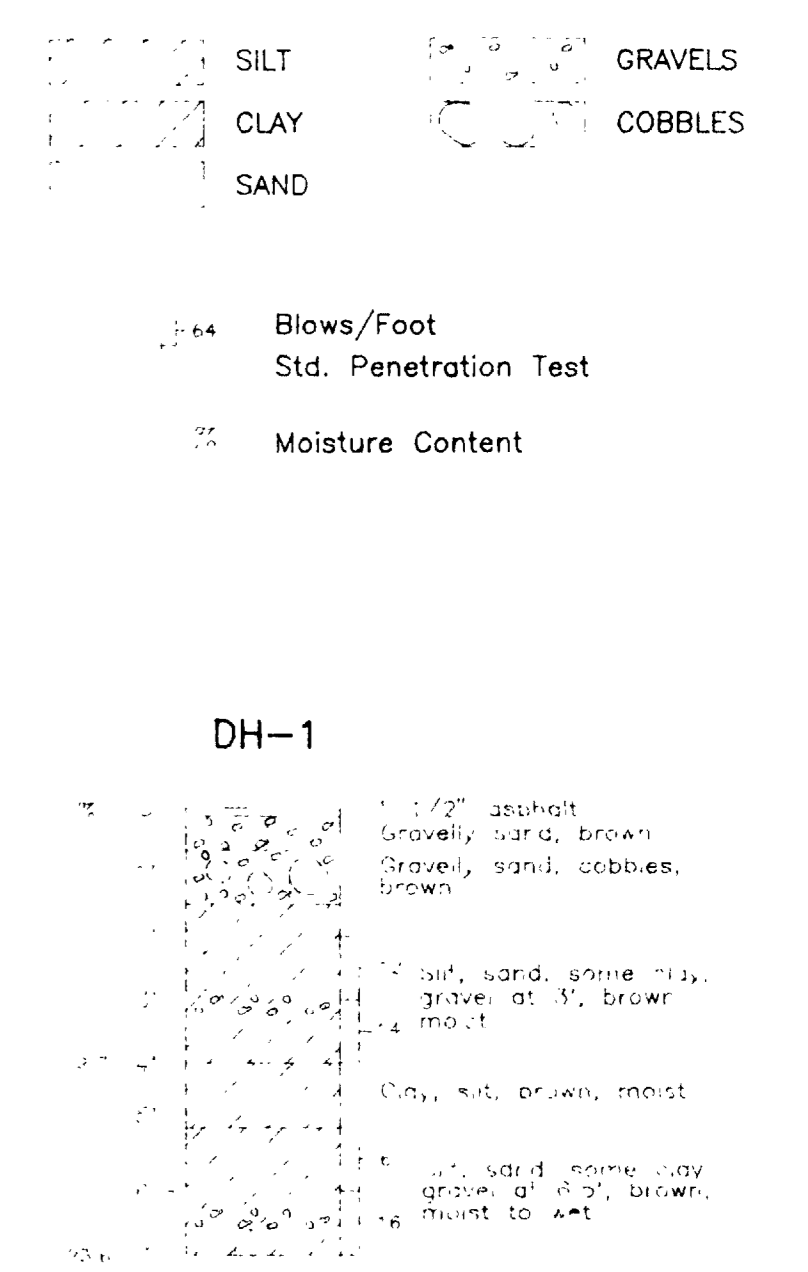

PLAN
1"=30'

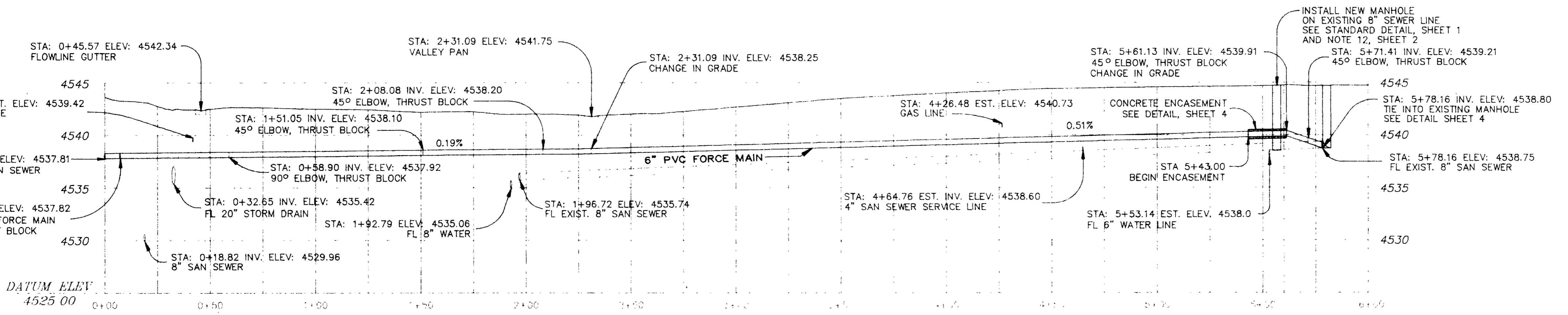

PROFILE
HORIZ. SCALE: 1"=30'
VERT. SCALE: 1"=6'

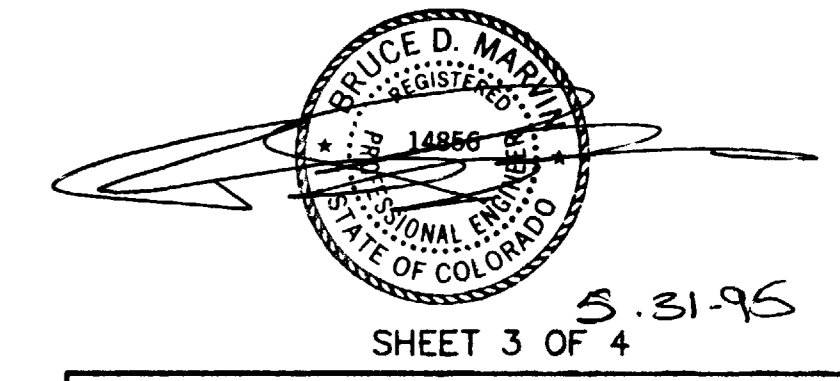
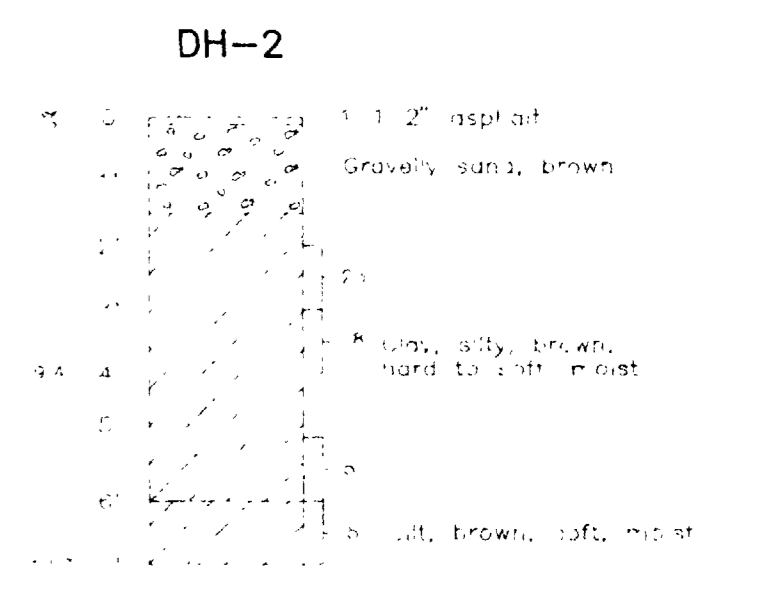

CITY OF GRAND JUNCTION
APPROVED FOR CONSTRUCTION BY:

TITLE	DATE

REVISIONS: 1-5, 30-95

SHEET 3 OF 4

PLAN AND PROFILE

BLUE HERON ROAD LIFT STATION
AND 6" PVC FORCE MAIN
GRAND JUNCTION, COLORADO

MESA COUNTY, COLORADO

DESIGN	G.L.L.	DRAWN	K.M.S.	CHECKED	G.L.L.
DATE	2-17-95	REVISED	NO	DATE	3690-0326-28

NOTE: ALL UNDERGROUND UTILITY LOCATIONS ARE APPROXIMATE ONLY AND REPRESENT LOCATIONS AS INDICATED BY QUALIFIED AGENTS AND/OR RECORDS OF RESPONSIBLE UTILITY COMPANY. ELEVATIONS AND STATIONS LISTED FOR EXISTING UTILITIES ARE NOT RELIED UPON FOR FIELD LOCATION. VERIFY AND FIELD LOCATE PRIOR TO ANY EXCAVATION, DRILLING OR GRADING. UTILITY NOTIFICATION CENTER (1-800-922-1987) MUST BE CALLED TWO BUSINESS DAYS IN ADVANCE.

ALL CABLES SHALL BE GALVANIZED OR COATED WITH LOW MODULUS BITUMINOUS COATING. CAUTION SHOULD BE EXERCISED DURING BACKFILLING TO PREVENT DAMAGE TO CABLES.

1/4" WIRE ROPE CABLE SHALL BE FASTENED AROUND FITTING BY REMOVING SLACK AND SECURING EACH CABLE WITH 2 CROSBY CLIPS SPACED 1 1/2" APART.

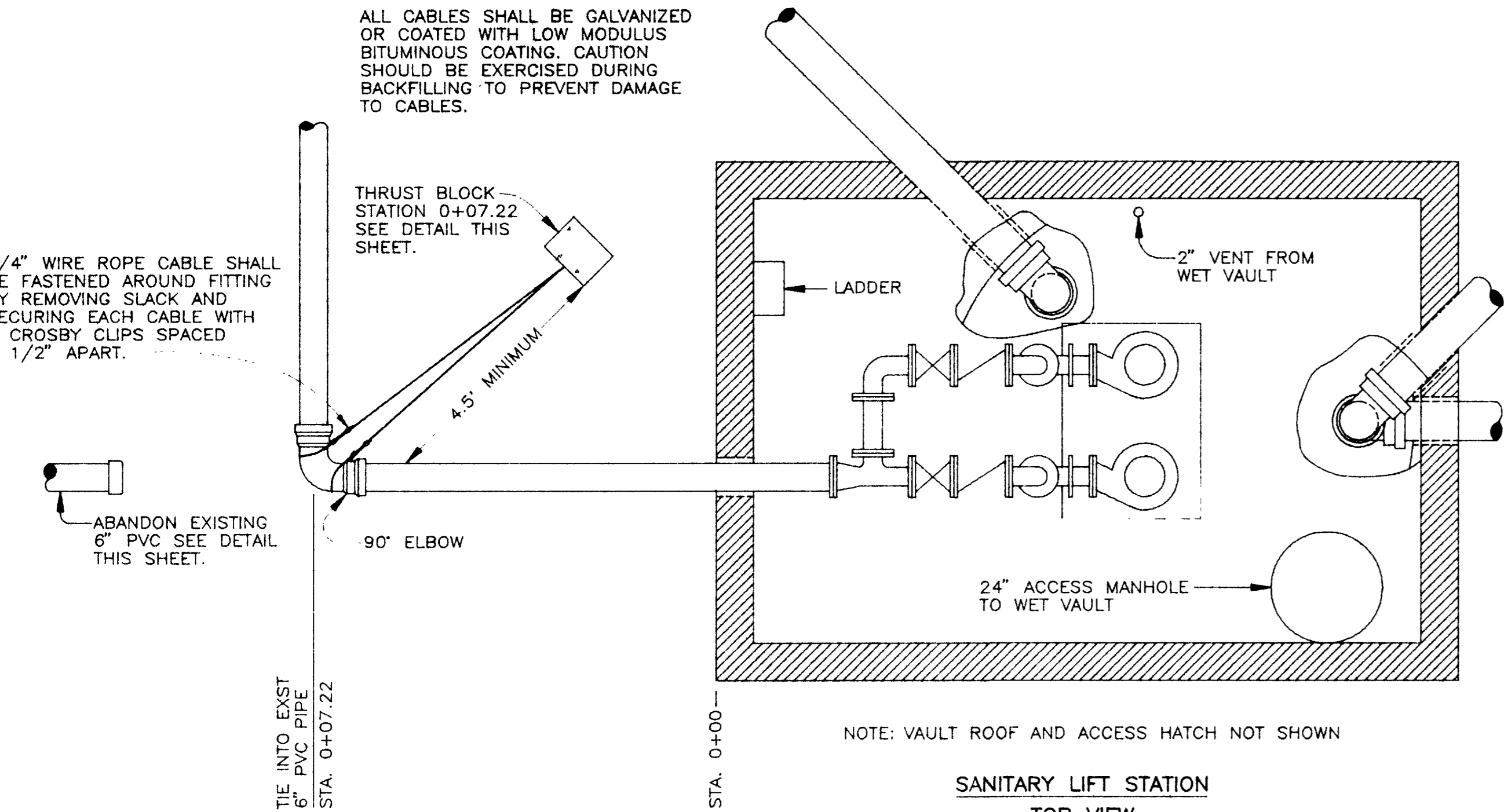

NOTE: VAULT ROOF AND ACCESS HATCH NOT SHOWN

SANITARY LIFT STATION
TOP VIEW
SCALE 1" = 2'

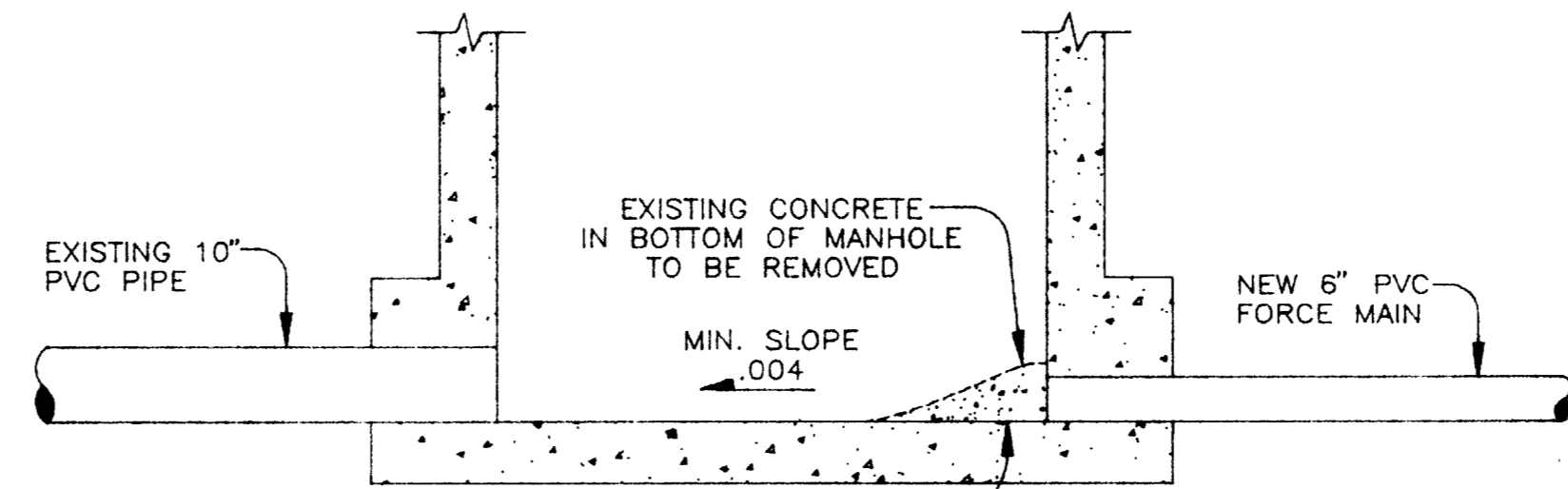

FIELD VERIFY SLOPE OF EXISTING FLOWLINE WITHIN MANHOLE. MINIMUM SLOPE SHALL BE .004 IN DIRECTION OF FLOW. IF FLOW LINE SLOPE REQUIRES MODIFICATION, AN EPOXY MORTAR UTILIZING AN EPOXY RESIN BINDER, SIKADUR 21 OR APPROVED EQUAL, SHALL BE FORMED WITHIN FLOWLINE TO ESTABLISH THE REQUIRED SLOPE. THE CONTRACTOR SHALL FOLLOW MANUFACTURER SPECIFICATIONS FOR MIXING AND APPLICATION PROCEDURES. CONCRETE SURFACE SHALL BE WIRE BRUSHED. CONCRETE SURFACE MUST BE CLEAN, SOUND AND FREE OF DUST PRIOR TO APPLICATION.

SECTION C-C
NOT TO SCALE

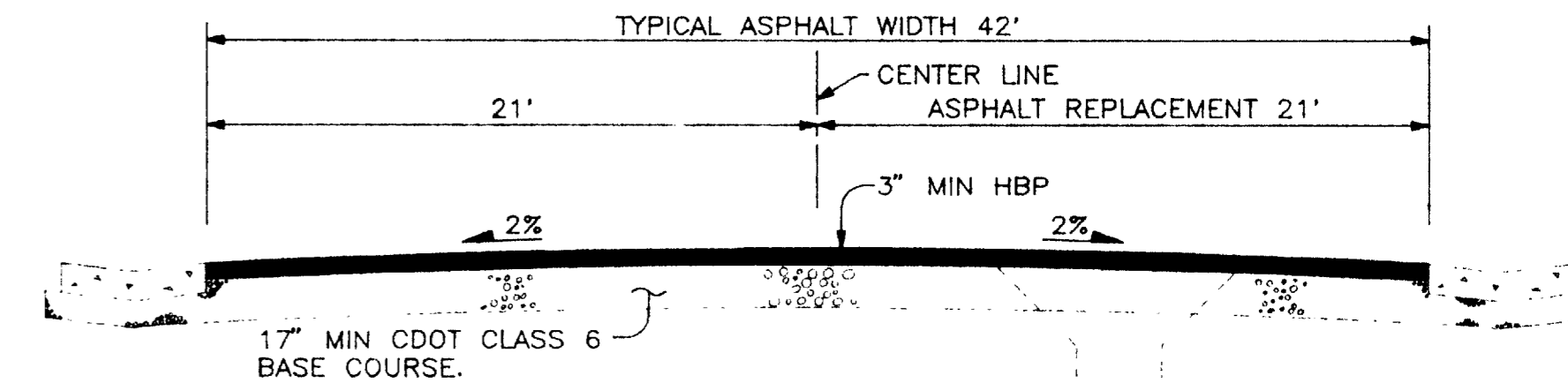

NOTE: IN AREAS WHERE EXISTING PAVEMENT THICKNESS IS LESS THAN 3", THE EXISTING BASE COURSE MUST BE REGRADED TO ALLOW THE MINIMUM 3" OF PAVEMENT TO BE PLACED.

TYPICAL PAVEMENT REPLACEMENT SECTION
NOT TO SCALE

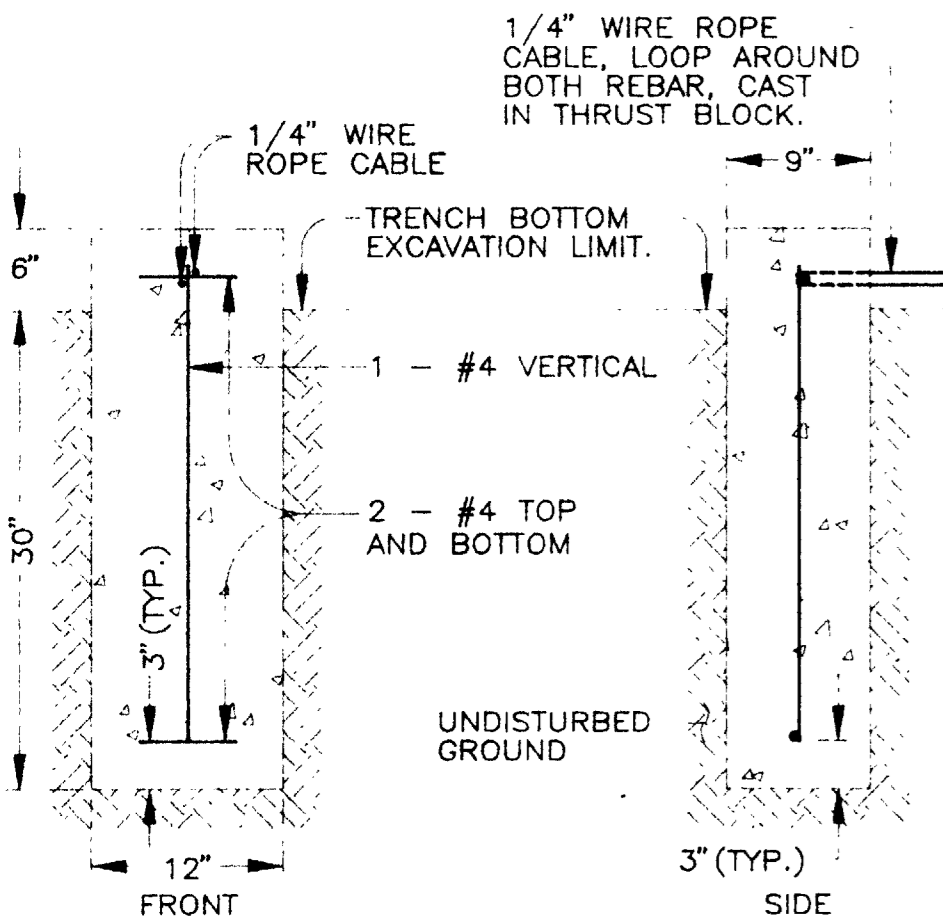

STA. 0+07.22
THRUST BLOCK DETAIL
SCALE 1" = 2'

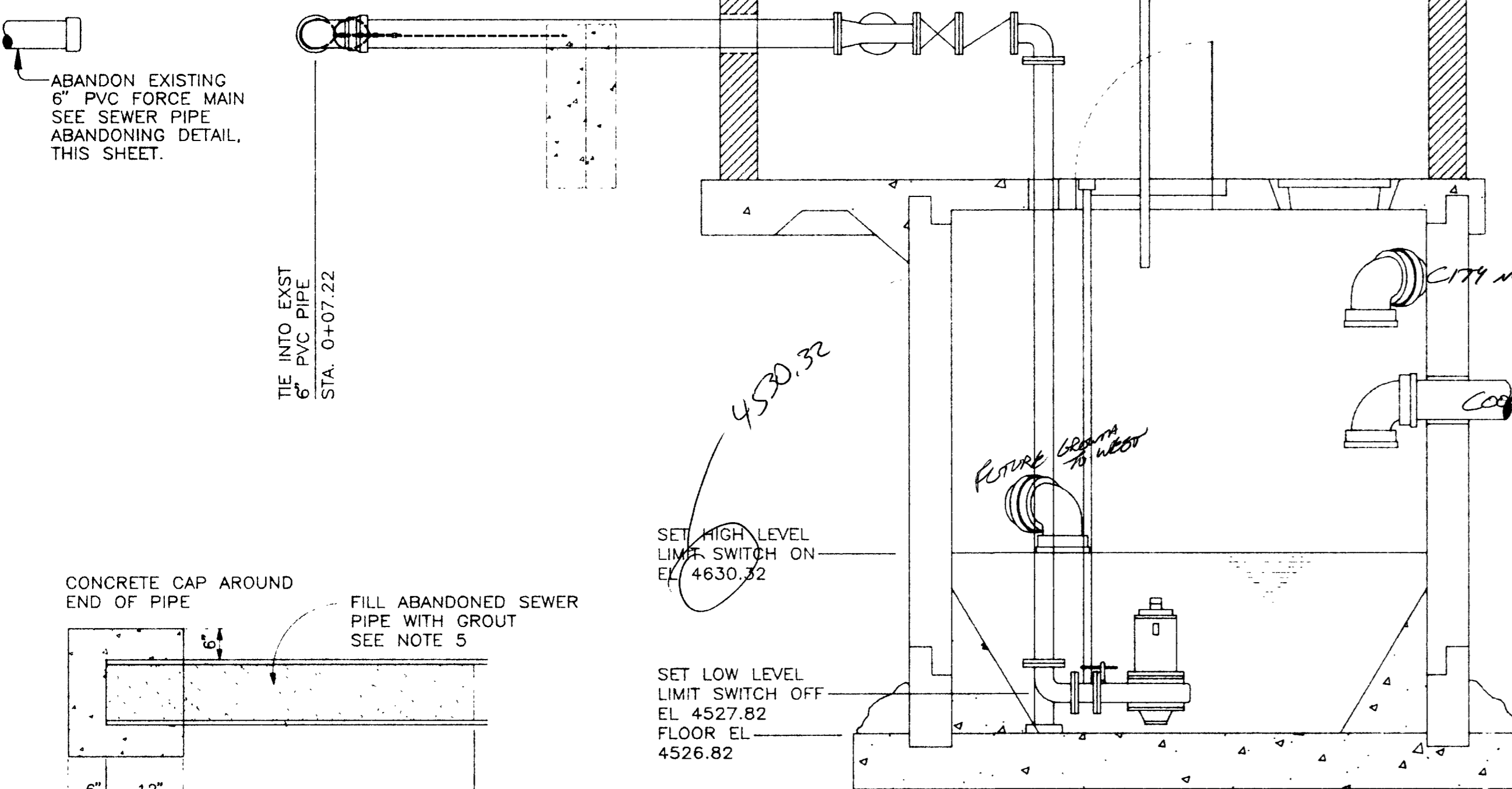

SANITARY LIFT STATION
SIDE VIEW
SCALE 1" = 2'

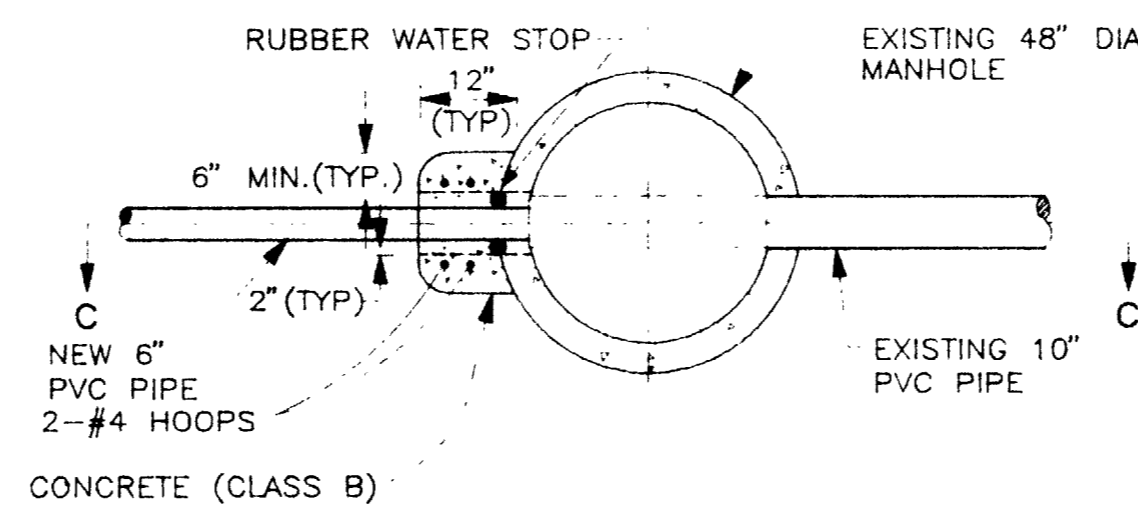

CONNECTION TO EXISTING
MANHOLE OR INLET BOX
NOT TO SCALE

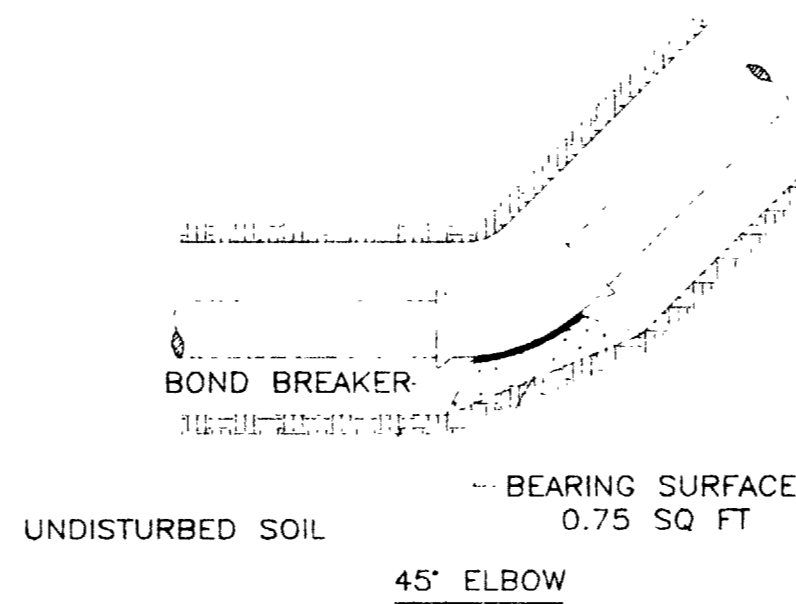

TYPICAL THRUST BLOCK DETAILS
NOT TO SCALE

NOTE: MECHANICAL RESTRAINTS MAY BE USED IN LIEU OF THRUST BLOCKS WITH PRIOR APPROVAL FROM THE CITY UTILITIES ENGINEER.

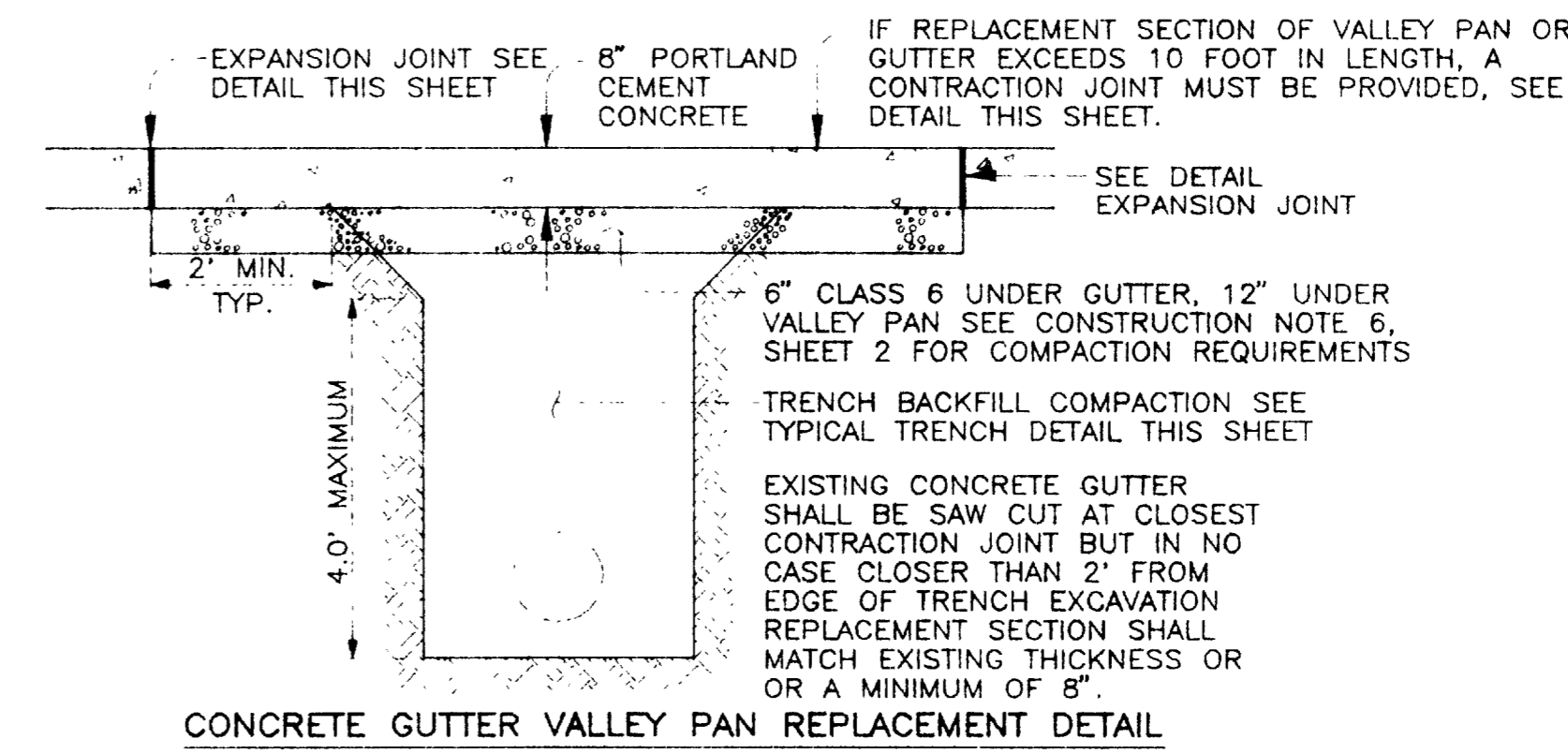

CONCRETE GUTTER VALLEY PAN REPLACEMENT DETAIL
NOT TO SCALE

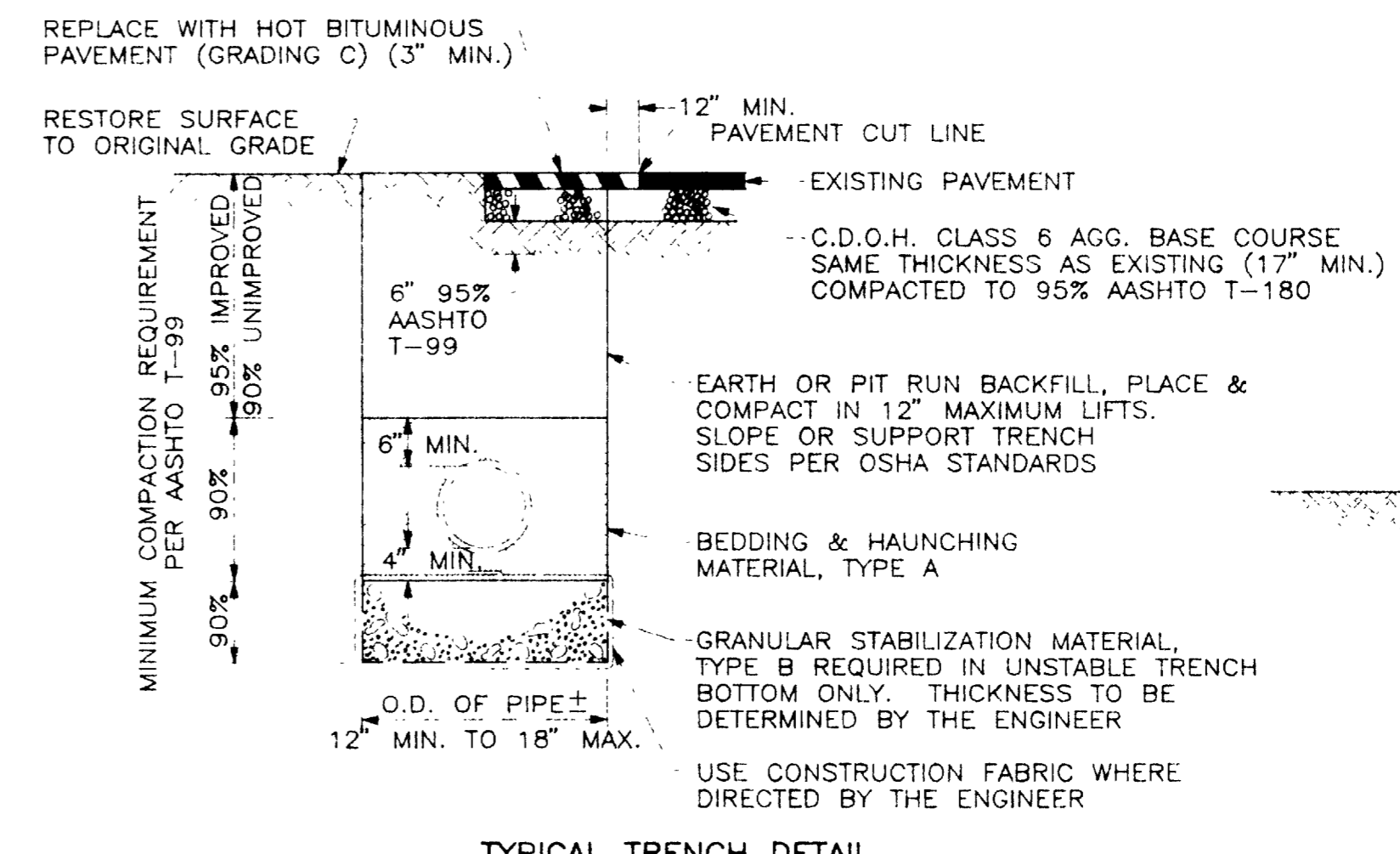

TYPICAL TRENCH DETAIL
NOT TO SCALE

SIEVE SIZE	PERCENT BY WEIGHT PASSING SQUARE MESH SIEVES		
	PIPE BEDDING & HAUNCHING MATERIAL (TYPE A)	GRANULAR STABILIZATION MATERIAL (SCREENED OR CRUSHED ROCK TYPE B)	PIT RUN AGGREGATE (TO BE USED WHERE SPECIFIED OR DIRECTED BY THE ENGINEER)
8 INCH	---	---	100
2 INCH	---	100	---
1 INCH	100	---	---
NO 4	---	15 MAX	30 MAX
NO 200	20 MAX	---	---

ALL BACKFILL MATERIAL SHALL BE PLACED FULL WIDTH IN 12" MAX. LIFTS AND COMPACTED TO THE MIN. DENSITIES SHOWN

NOTE: NATIVE MATERIAL MAY BE USED IN LIEU OF GRANULAR BEDDING & HAUNCHING MATERIAL IF APPROVED BY THE CITY ENGINEER AND THE NATIVE MATERIAL IS IN COMPLIANCE WITH SIZE REQUIREMENTS FOR "TYPE A".

CITY OF GRAND JUNCTION
APPROVED FOR CONSTRUCTION BY:

TITLE	DATE

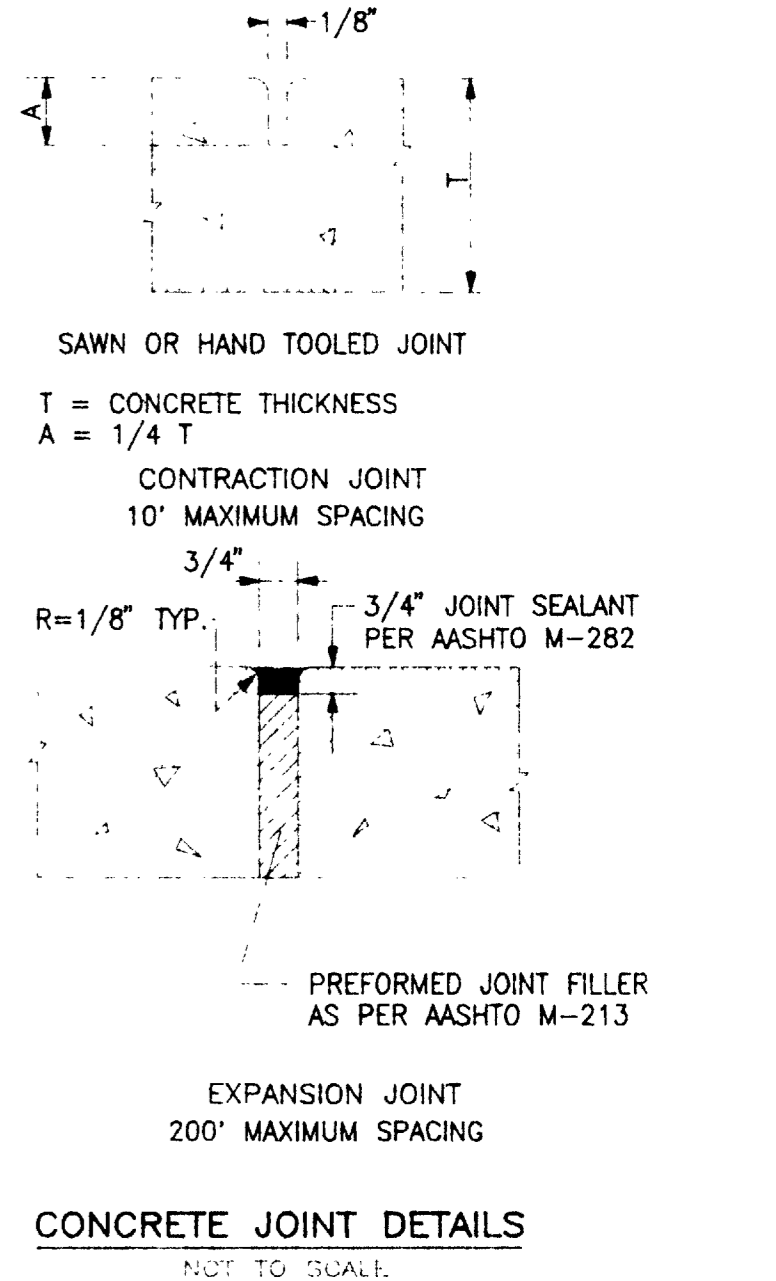

CONCRETE JOINT DETAILS
NOT TO SCALE

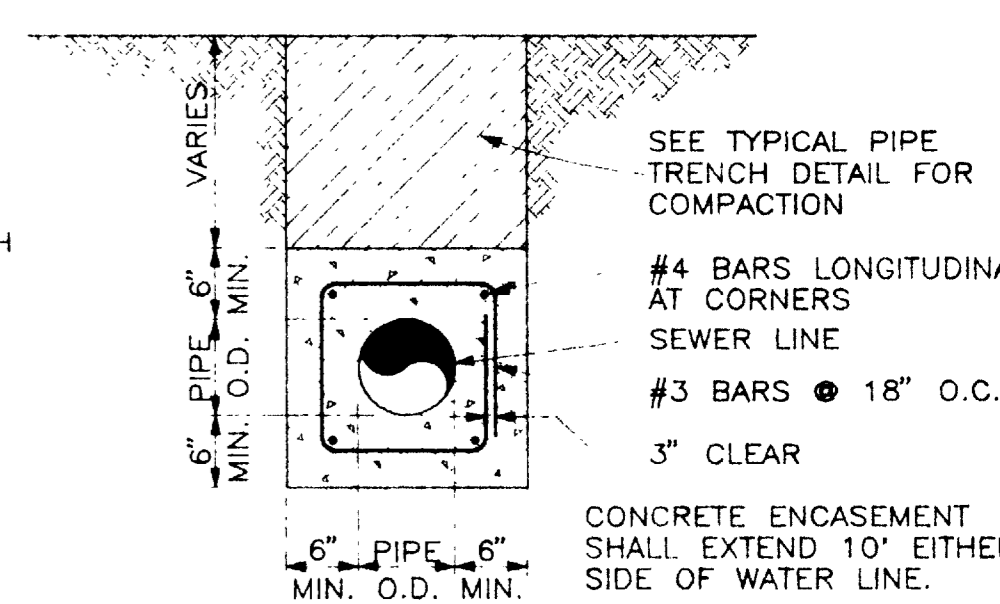

WATER LINE BELOW SEWER LINE
CONCRETE ENCASEMENT
DETAILS
NOT TO SCALE

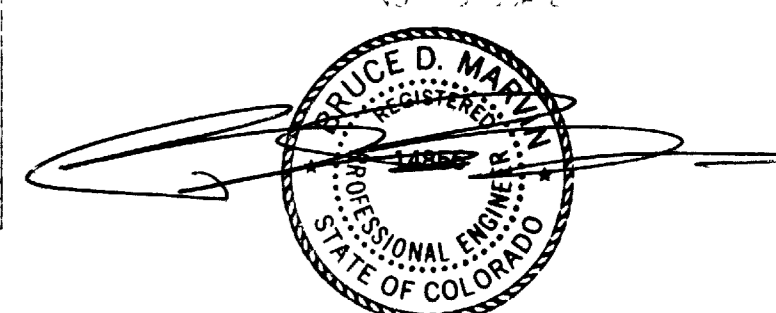

5.31.95
SHEET 4 OF 4

REVISIONS: 5-31-95

BLUE HERON ROAD LIFT STATION
AND 6" PVC FORCE MAIN
GRAND JUNCTION, COLORADO

MESA COUNTY, COLORADO

DATE	BY	REASON
2-17-95	G.L.L.	REVISED

3690-326-28